

FPGA Package Top View

Notes:

- FPGA Schematic Symbol Breakdown:
 - (A) Banks 3A
 - (B) Banks 3B (EP2AGX260)
 - (C) Banks 4A,4B
 - (D) Banks 5A
 - (E) Banks 5B (EP2AGX260)
 - (F) Banks 6A
 - (G) Banks 6B (EP2AGX260)
 - (H) Banks 7A,7B
 - (I) Bank 8A
 - (J) Clocks
 - (K) Configuration
 - (L) Power
 - (M) IO Power
 - (N) GND1
 - (O) Transceivers
 - (P) Transceiver Power
- Board can support the EP2AGX125EF35 and EP2AGX260EF35 devices.

Symbol	Pin Type
	User I/O
	User Assigned I/O
	Fitter Assigned I/O
	Unbonded Pad
	Reserved Pin
	DEV_OE
	DEV_CLR
	DIFF_n
	DIFF_p
	DQ
	DQS
	DQSB
	CQ#
	Other PLL
	Other Dual Purpose
	CLK_n
	CLK_p
	GX_X*n
	GX_X*p
	MSEL0
	MSEL1
	MSEL2
	MSEL3
	CONF_DONE
	DCLK
	nCE
	nCONFIG
	DATA0
	TDI
	TCK
	TMS
	TDO
	nSTATUS
	nIO_PLLUP
	Other Dedicated Programming
	VREF
	VCCP/VCCR/VCC
	VCCA
	VCCIO
	GND
	RREF
	No Connect

BANK 6B
(EP2AGX260 only)
VCCIO = 2.5V
HSMC Port B

BANK 6A
VCCIO = 2.5V
HSMC Port A,
Flash Control, FSM Address,
LCD, DIP Switch, LEDs,
PCIe Control

BANK 5A
VCCIO = 2.5V
HSMC Port A

BANK 5B
(EP2AGX260 only)
VCCIO = 2.5V
HSMC Port B

BANK 7A
VCCIO = 1.5V
DDR3 Device (128MB)

BANK 7B, 8A
VCCIO = 2.5V
ENET, FSM Bus, SSRAM

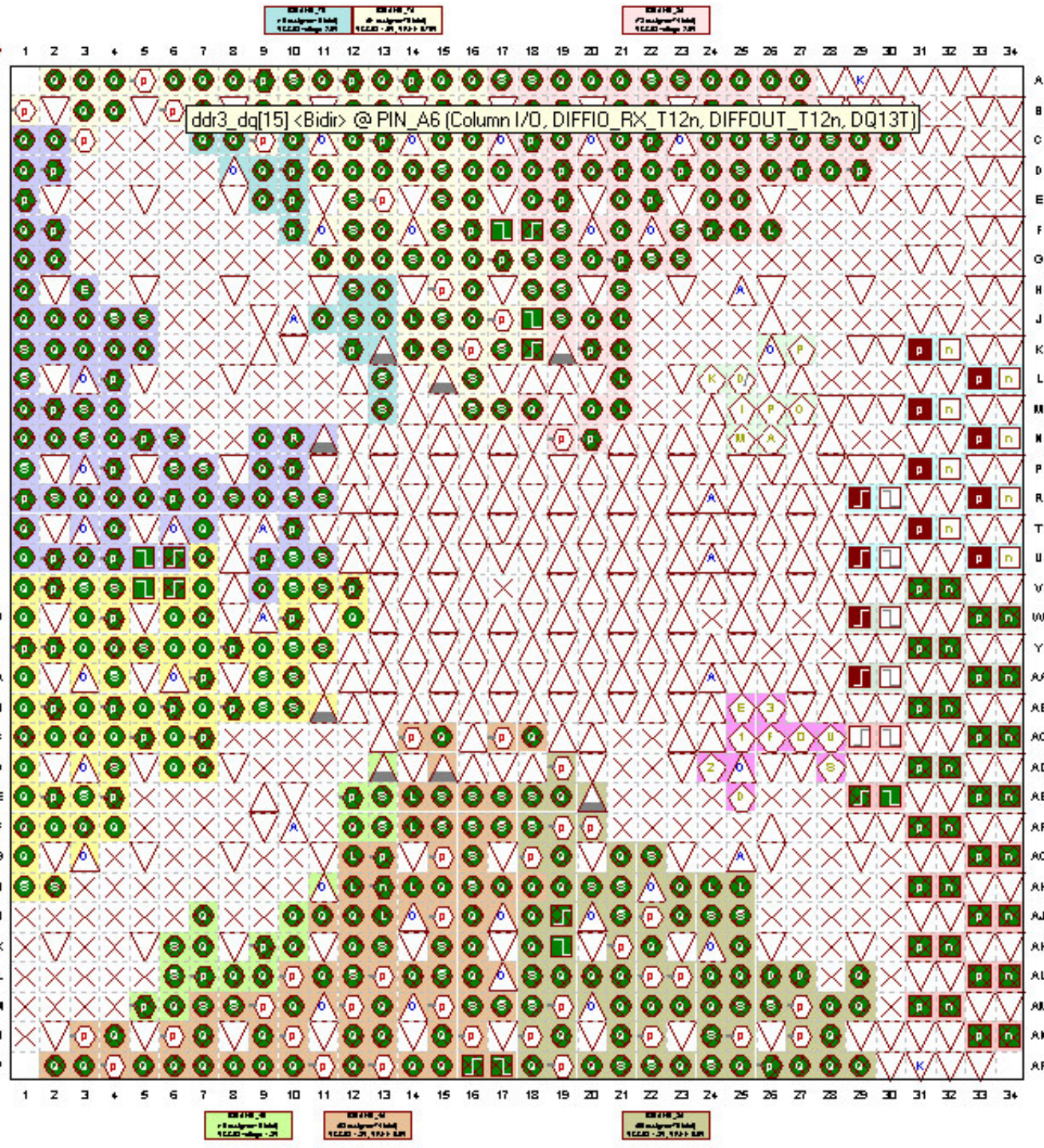

XCVR BANK QR3 (EP2AGX260 only)
HSMC Port B x4

XCVR BANK QR2
HSMC Port A x4

XCVR BANKS QL0, QL1
PCI Express x8
PCIe REFCLK

BANK 4B
VCCIO = 1.8V
DDR2 SODIMM x64
Push-buttons

BANK 4A & 3A
VCCIO = 1.8V
DDR2 SODIMM x64

BANK 3B
(EP2AGX260 only)
VCCIO = 2.5V
HSMC Port B



Copyright (c) 2009 Altera Corporation. All Rights Reserved.		
Title Arria II GX FPGA Development Kit Board		
Size B	Document Number 150-0320801-C1 (6XX-40784R)	Rev C
Date: Friday, August 07, 2009	Sheet 2	of 29

MAX II EPM2210

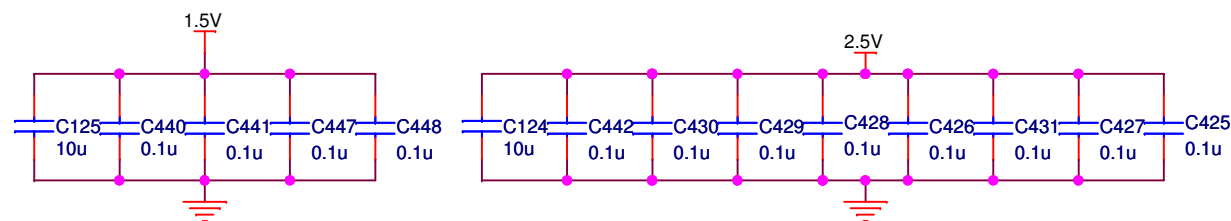
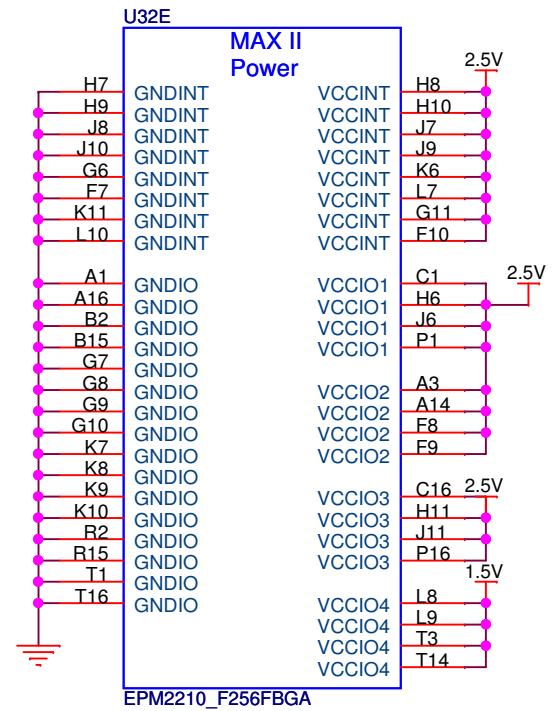
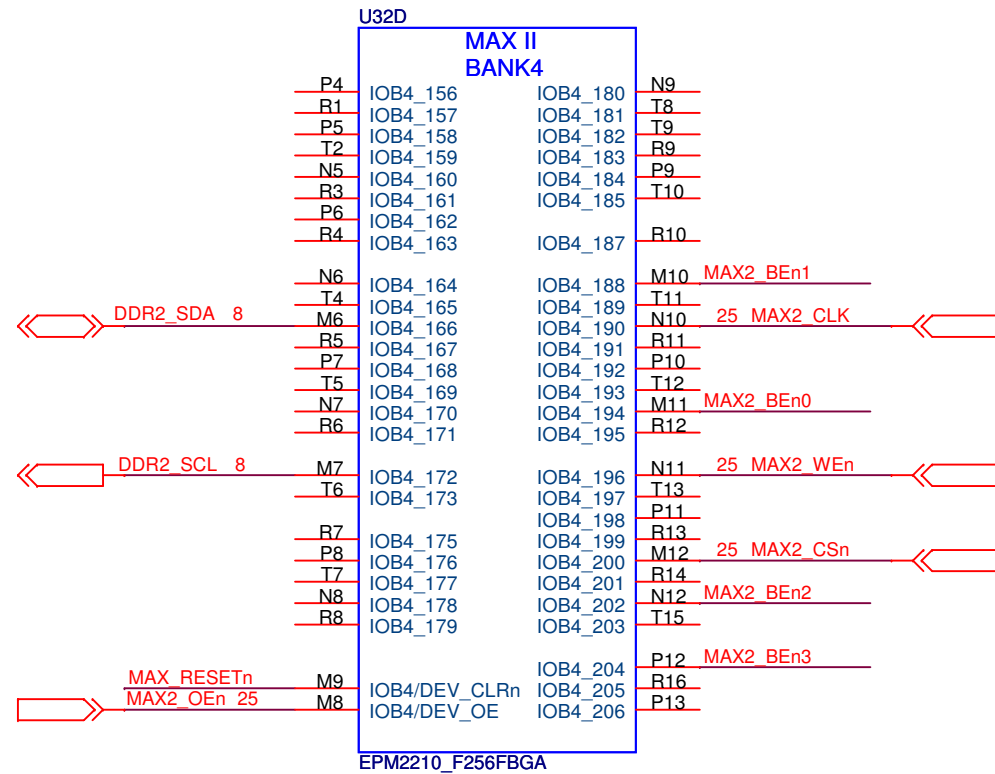
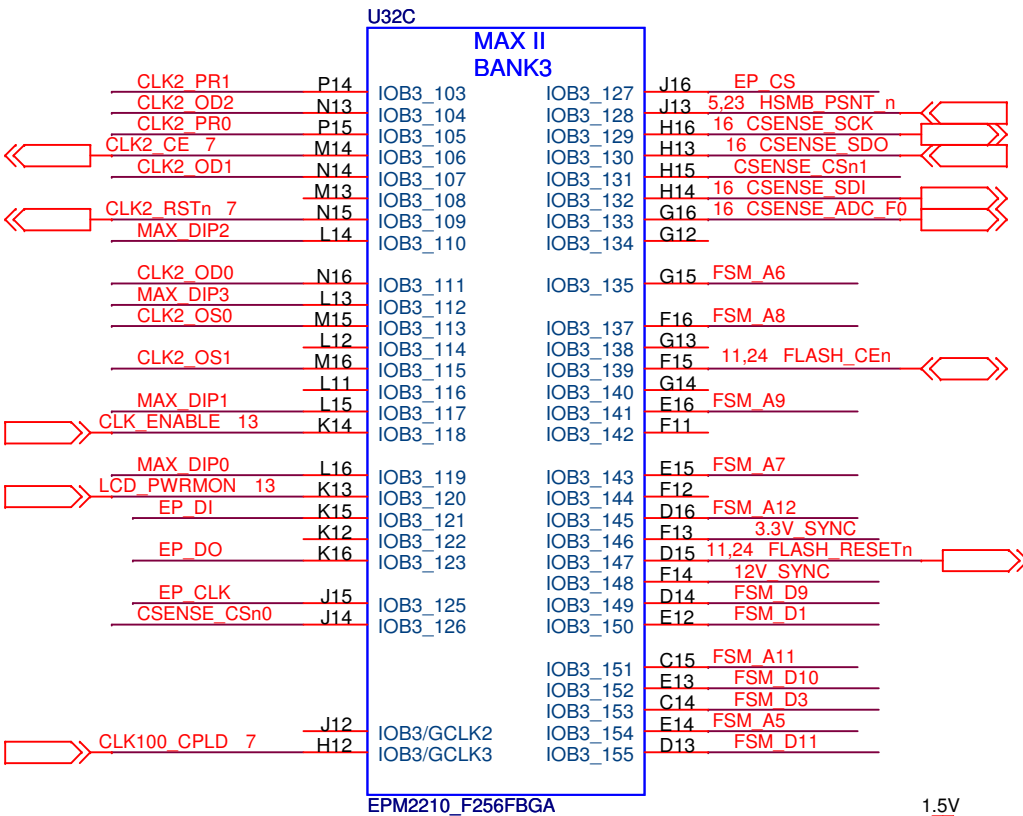
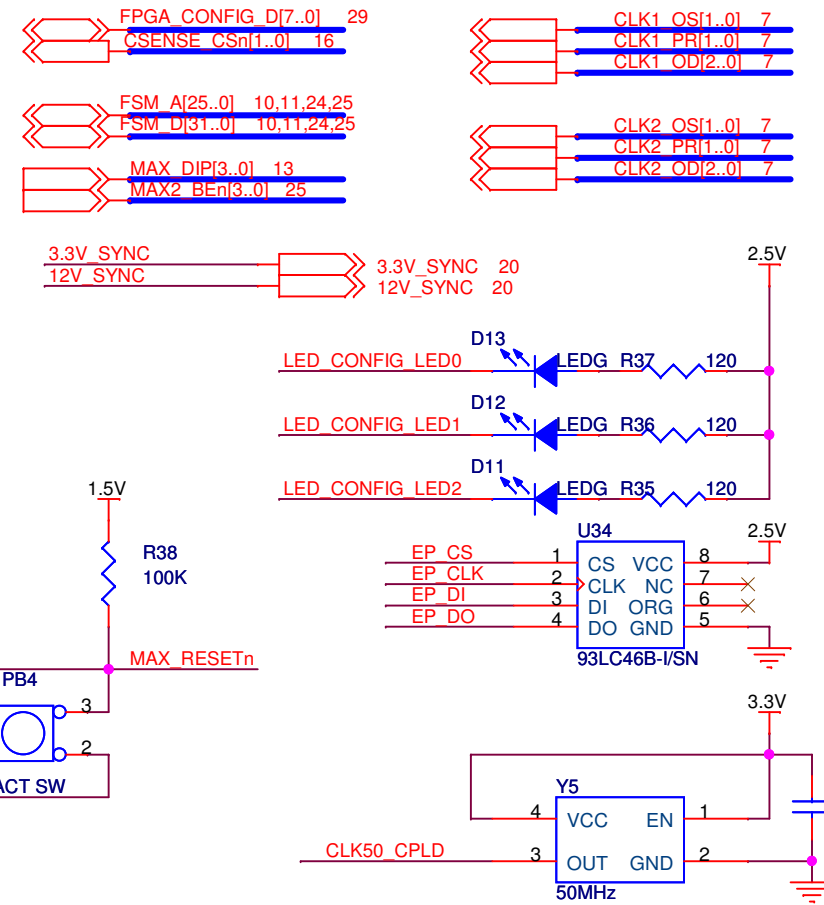
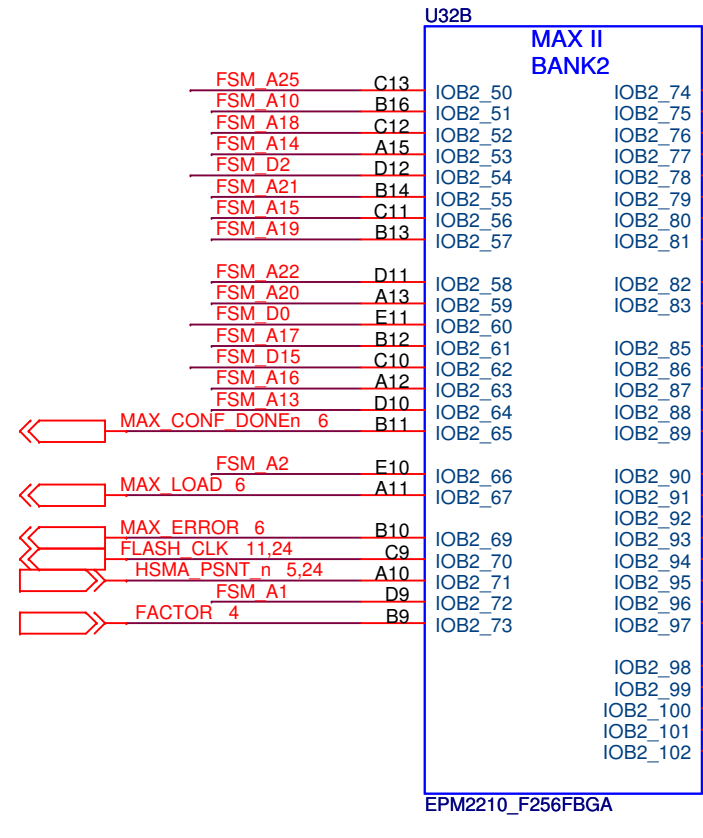
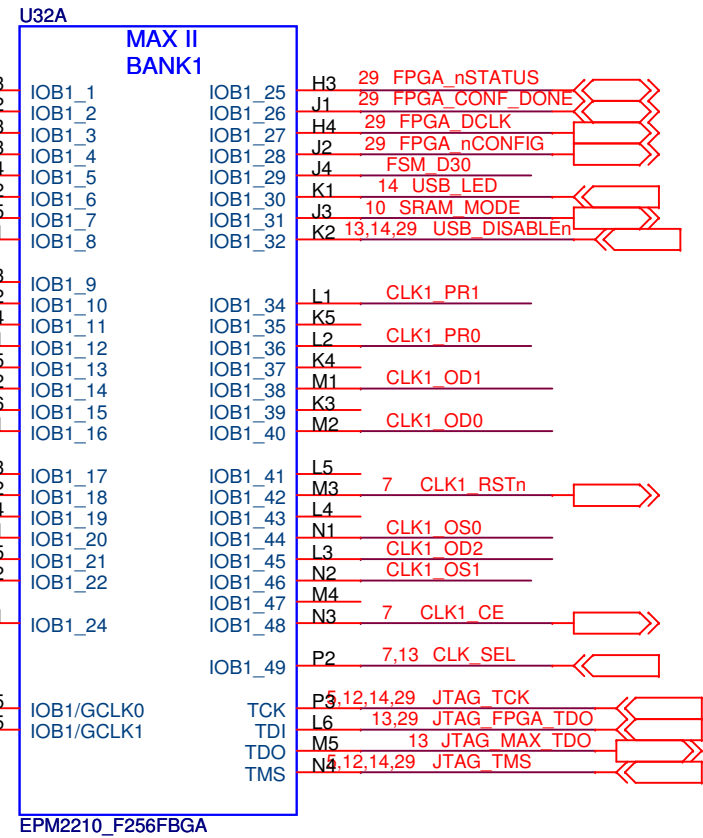

Copyright (c) 2009 Altera Corporation. All Rights Reserved.		
Title Arria II GX FPGA Development Kit Board		
Size B	Document Number 150-0320801-C1 (6XX-40784R)	Rev C
Date: Wednesday, August 12, 2009	Sheet 3	of 29

Buttons & Switches

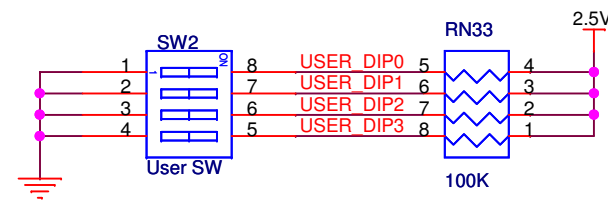
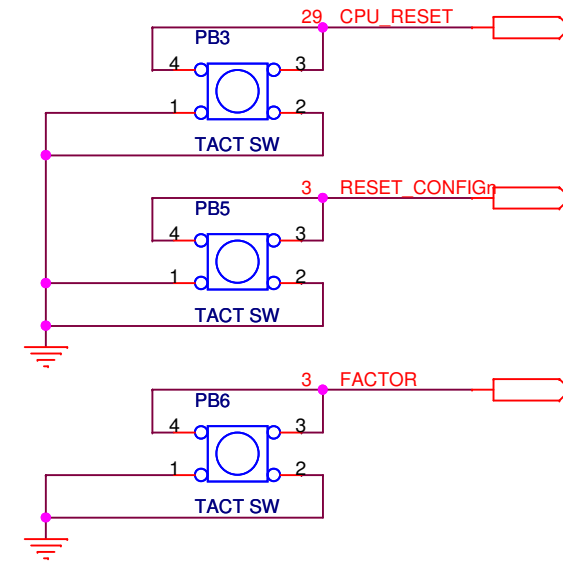
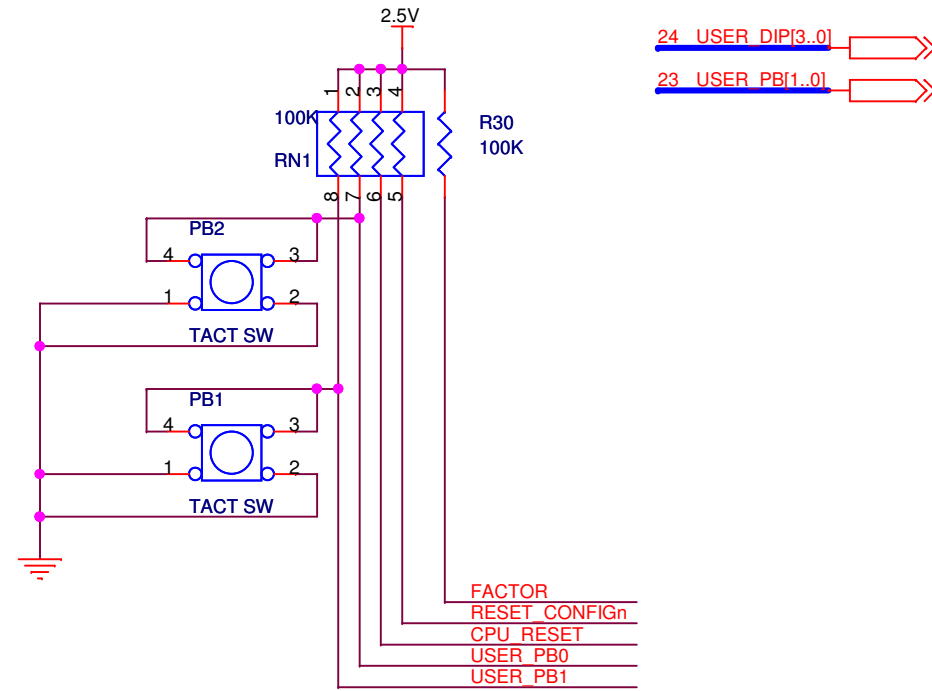

HSMC Port A & Port B

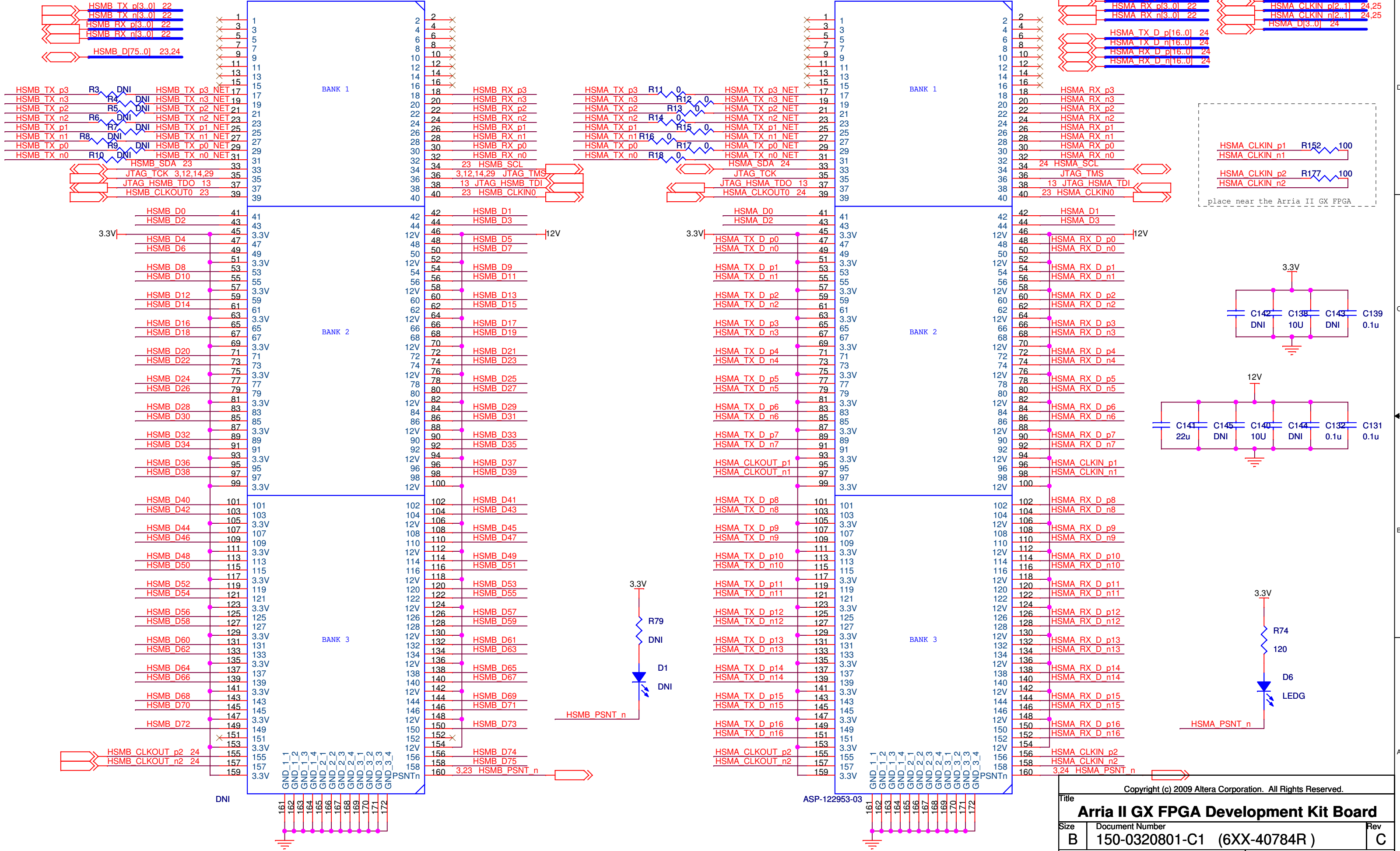

LCD & LEDs

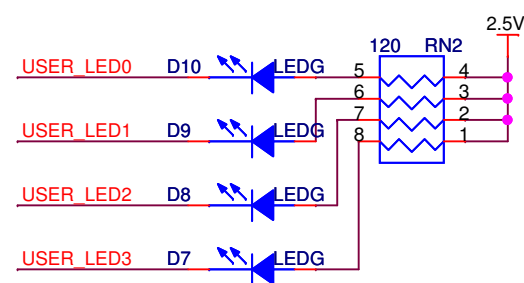
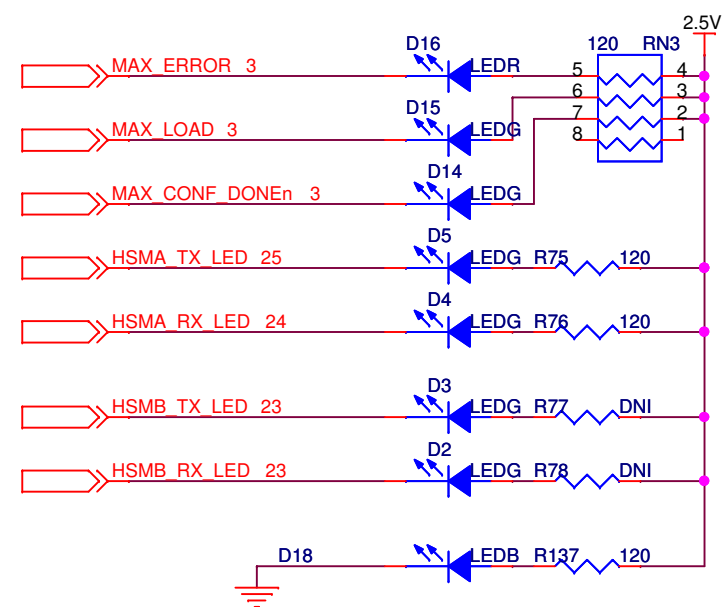
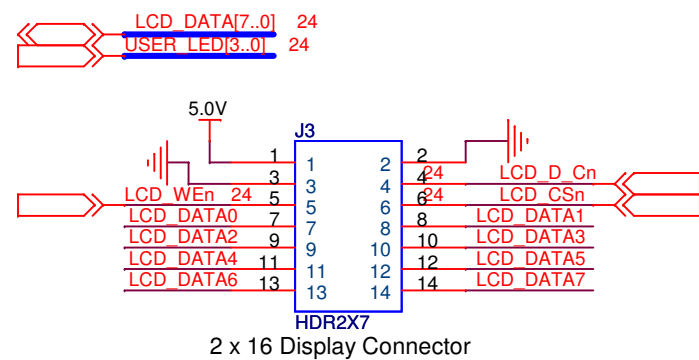

Oscillators

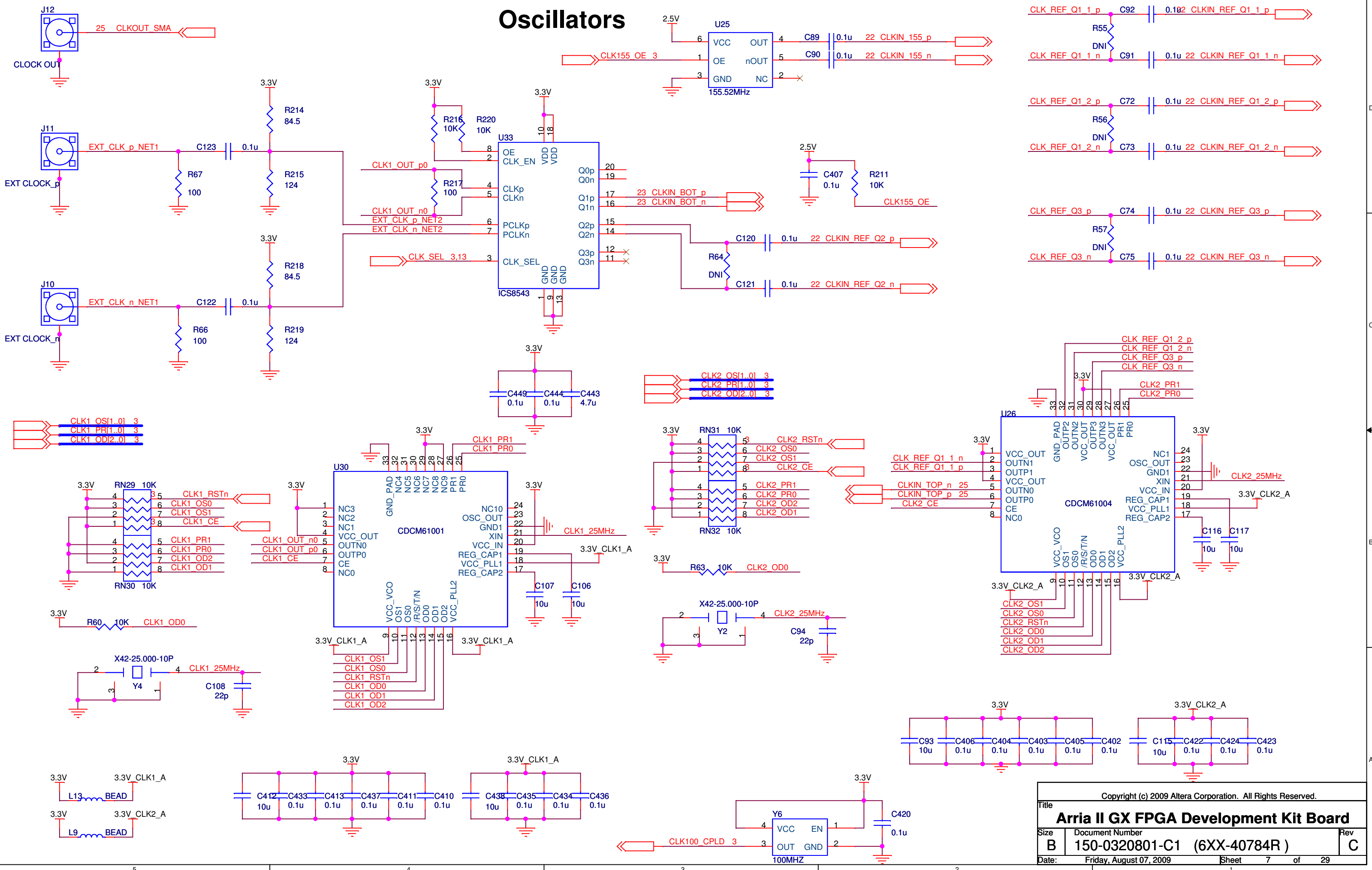

Copyright (c) 2009 Altera Corporation. All Rights Reserved.		
Title		
Arria II GX FPGA Development Kit Board		
Size	Document Number	Rev
B	150-0320801-C1 (6XX-40784R)	C
Date:	Friday, August 07, 2009	Sheet 7 of 29

DDR2 SO-DIMM

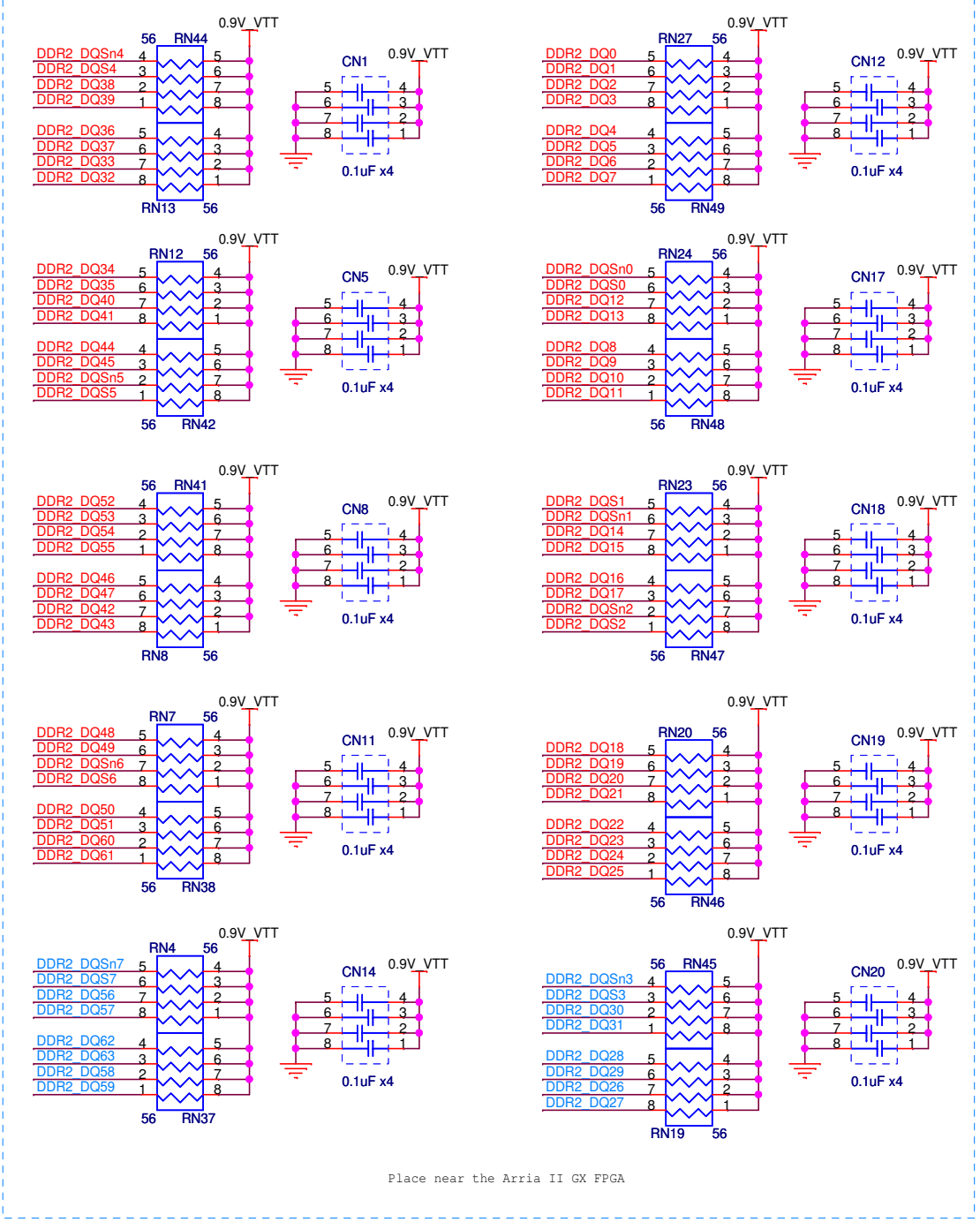

Place near the Arria II GX FPGA

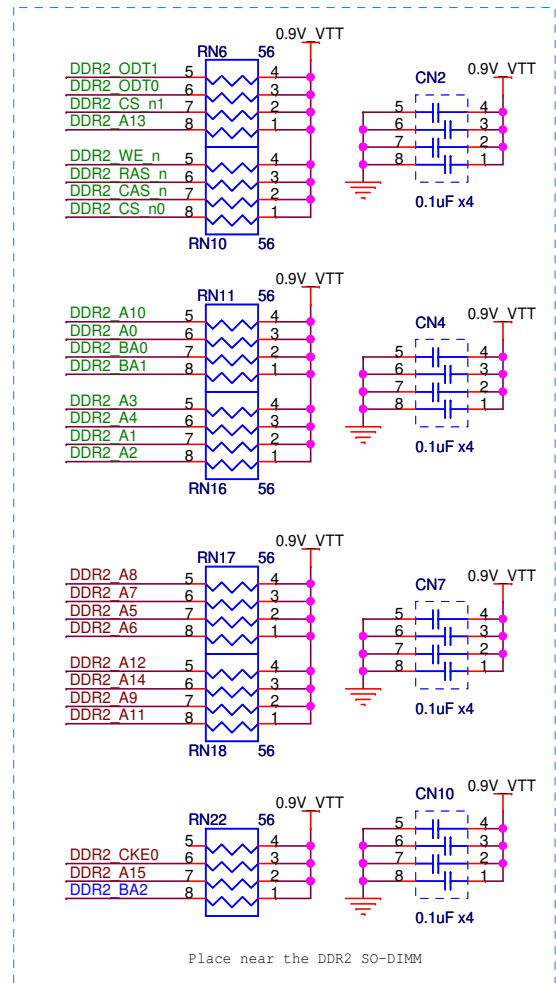
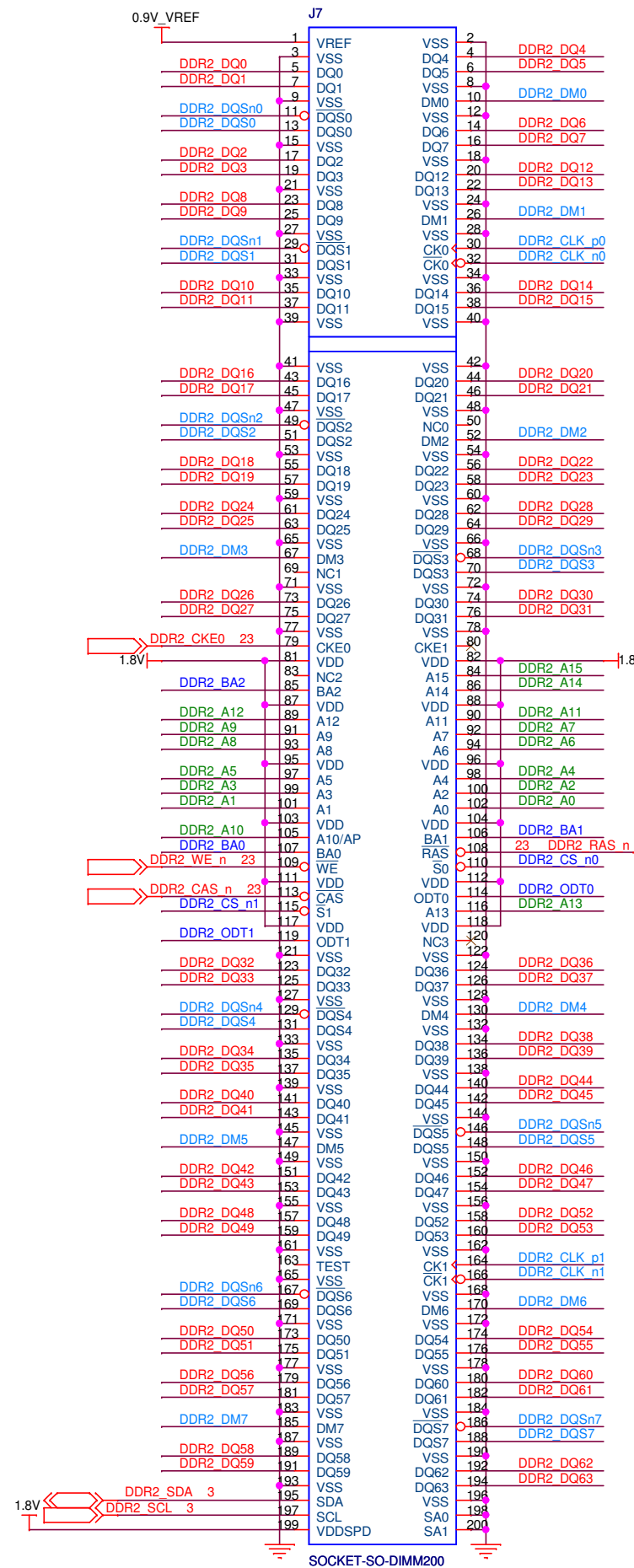
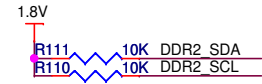

Place near the DDR2 SO-DIMM

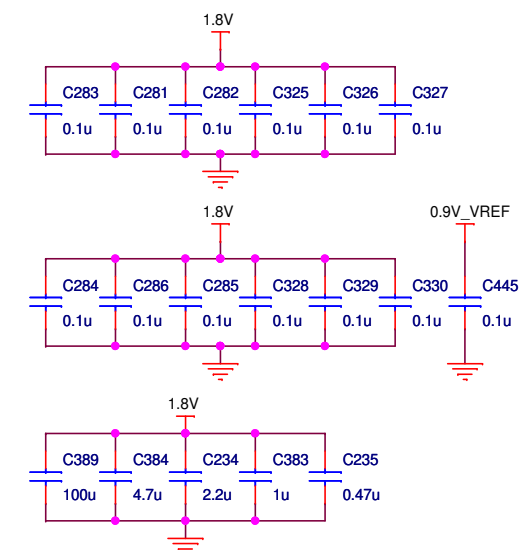

DDR3 Memory Device

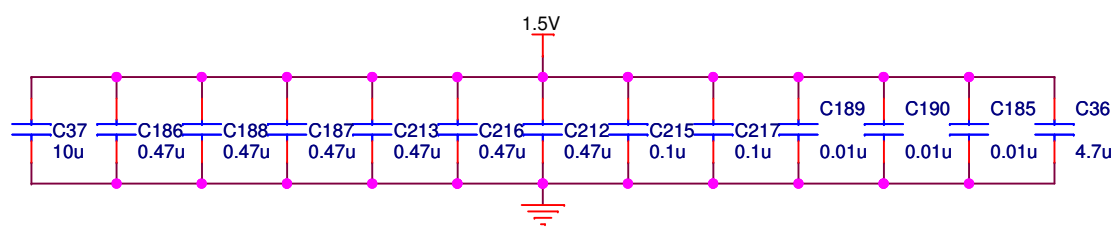
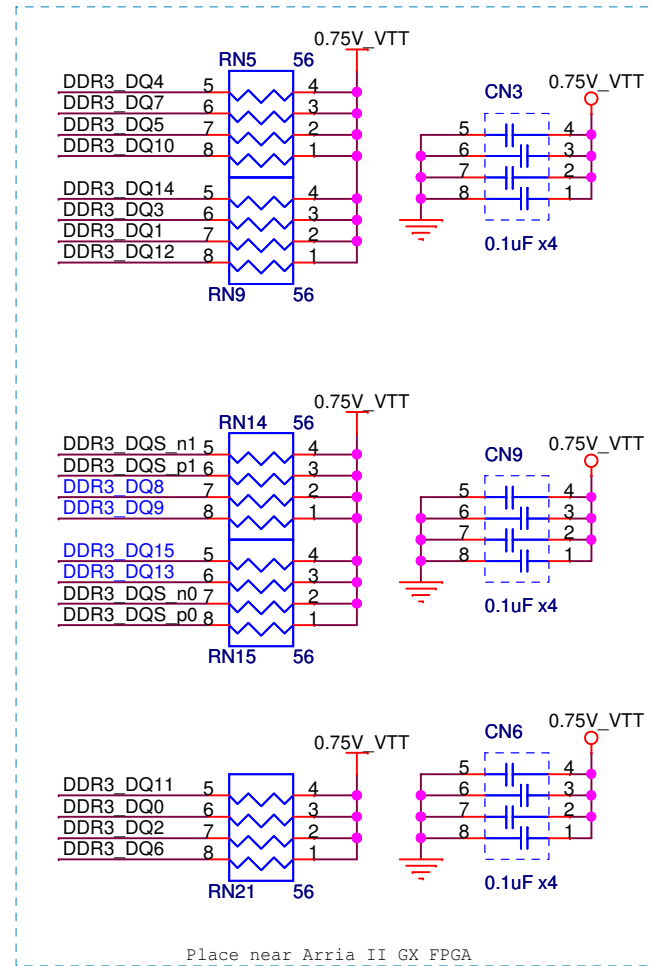
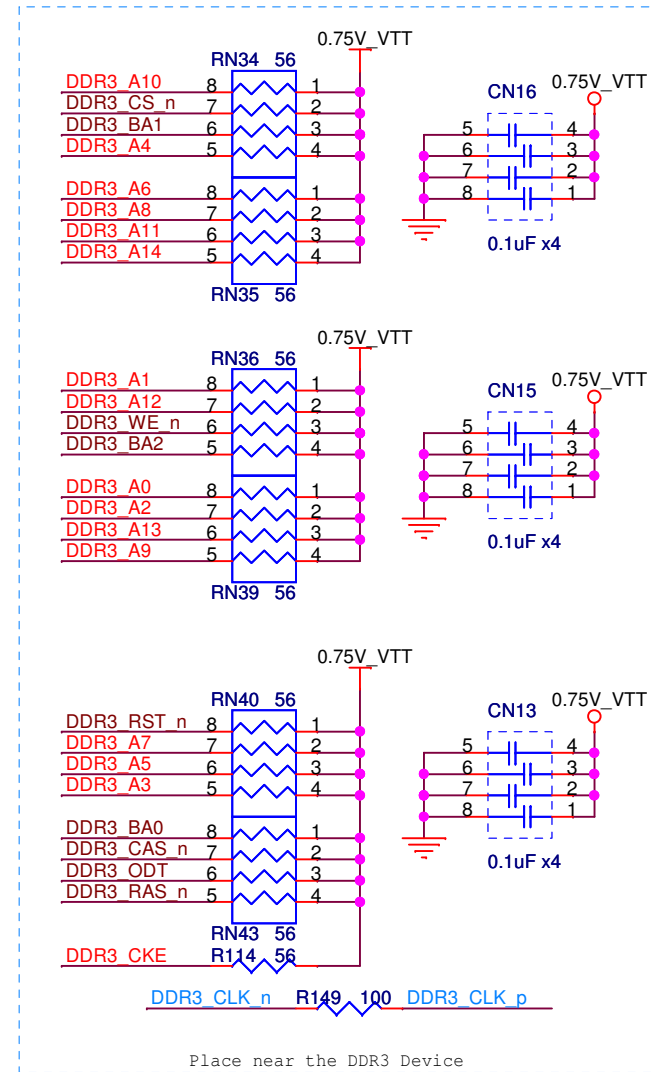
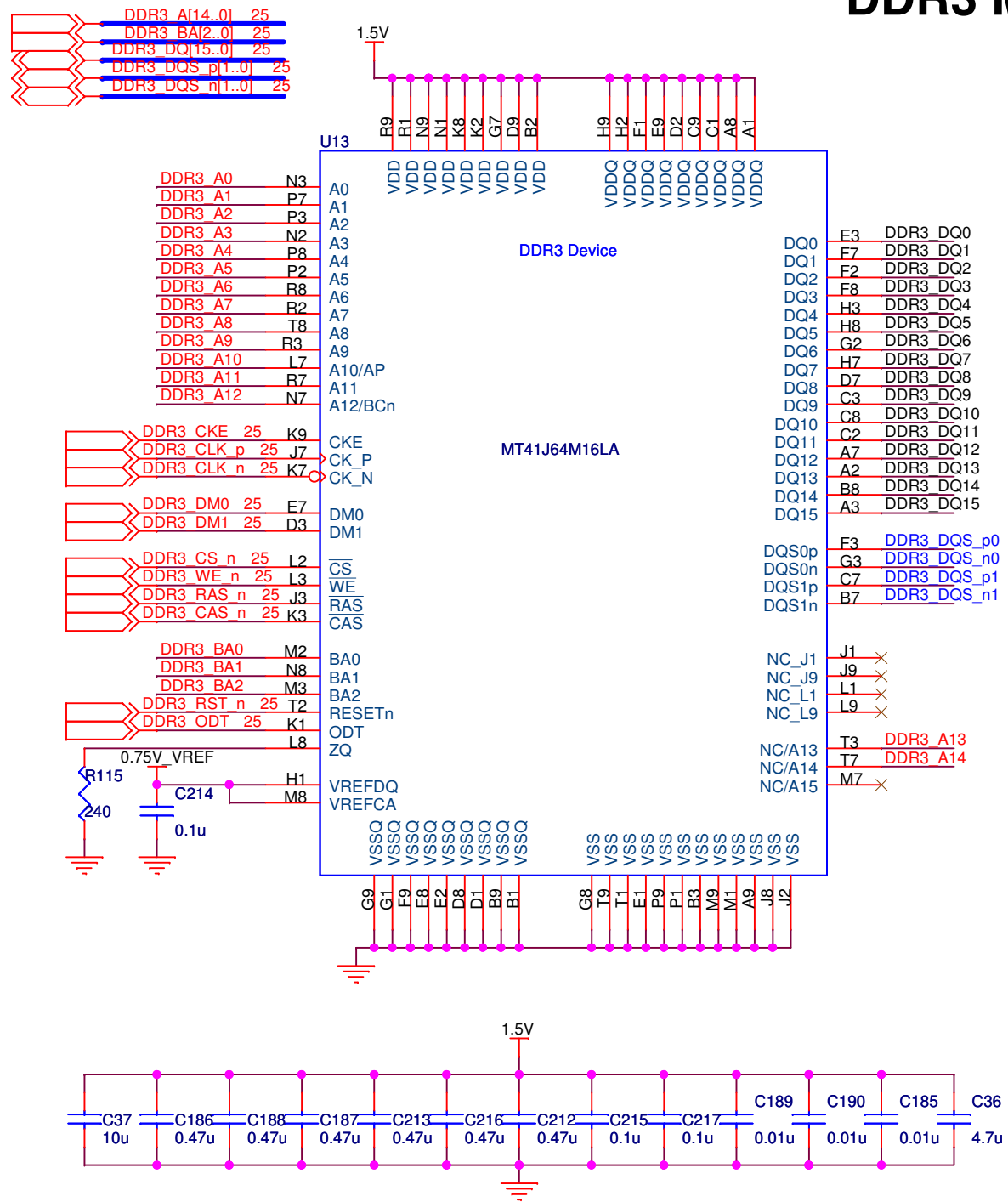

SSRAM

FSM D[31..0] 3,11,24,25
 SRAM DQP[3..0] 24,25
 FSM A[22..2] 3,11,24,25
 SRAM BEn[3..0] 25

NOTE:
 SSRAM 256Kx36
 SSRAM 512Kx36 (Default)
 SSRAM 1Mx36
 SSRAM 2Mx36

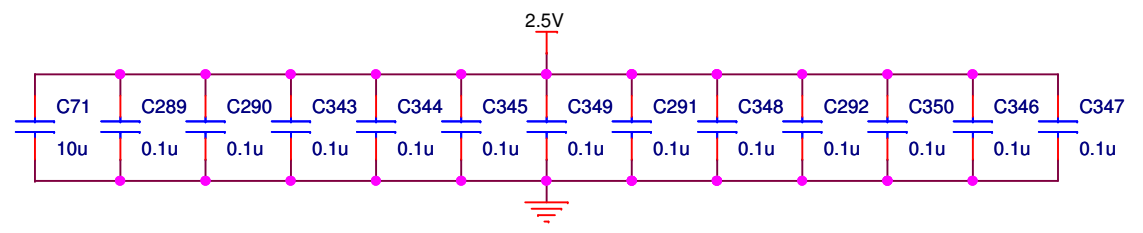
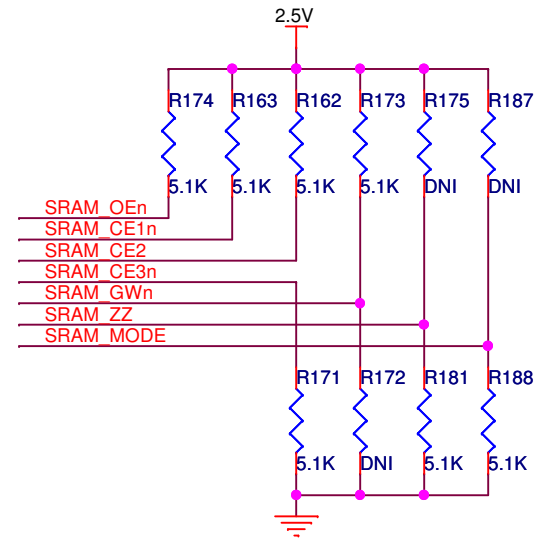
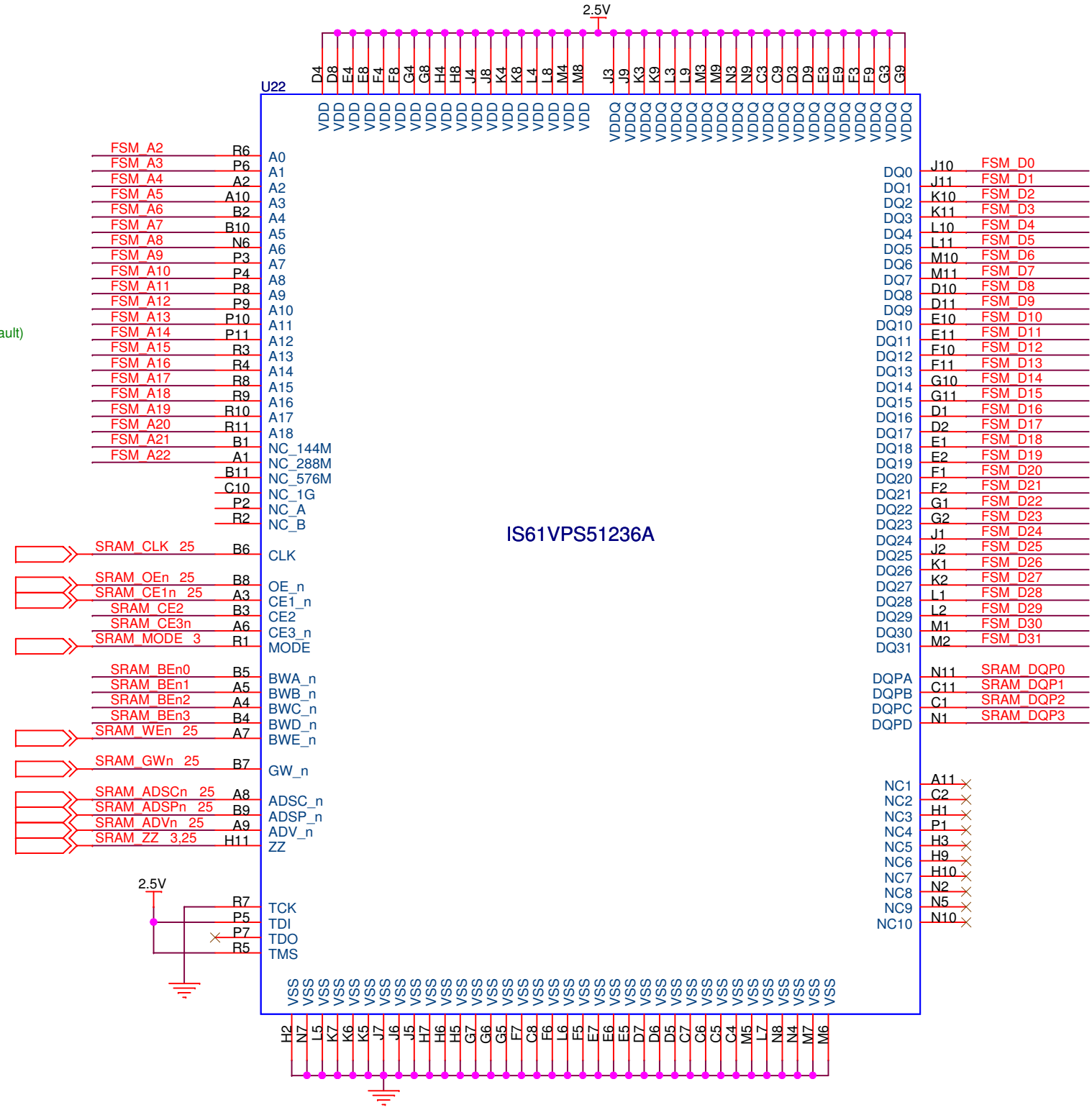

Sync Flash

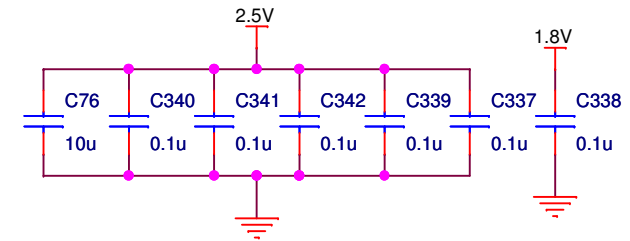
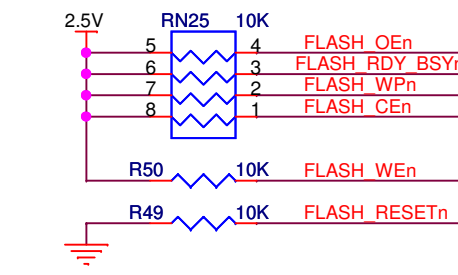
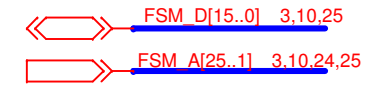
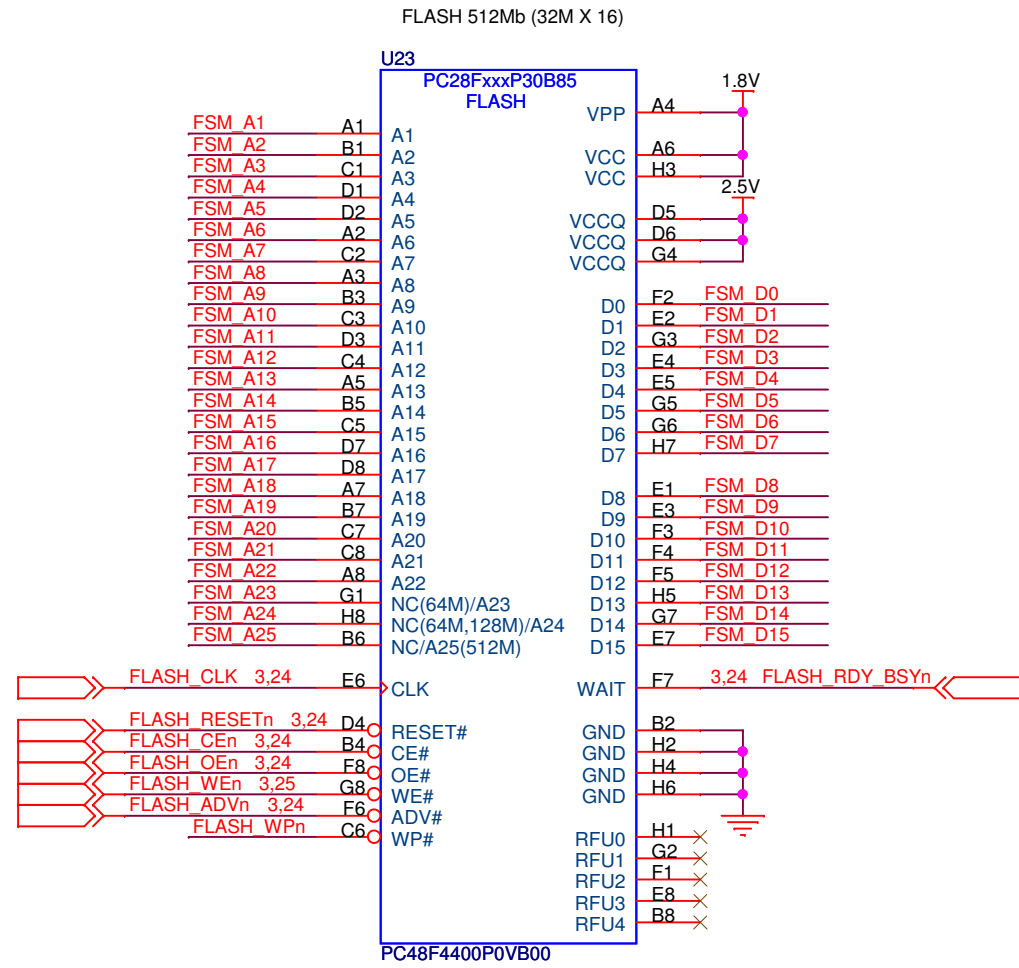

PCIe x8 Edge Connector

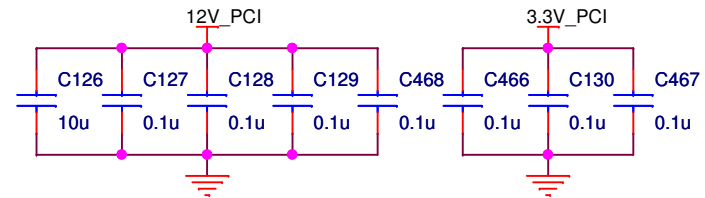
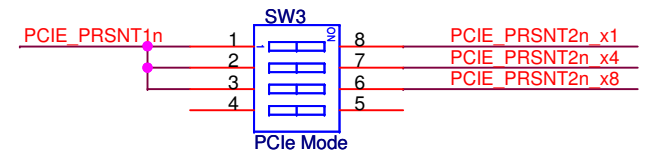
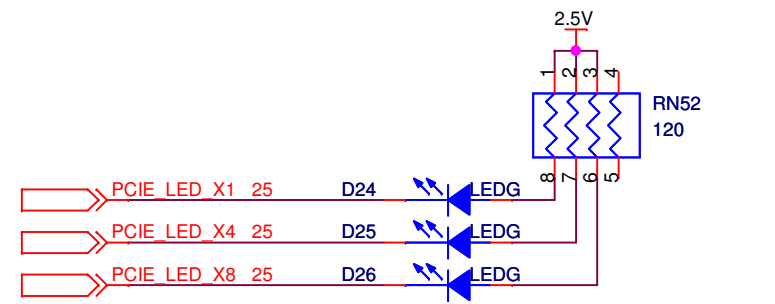
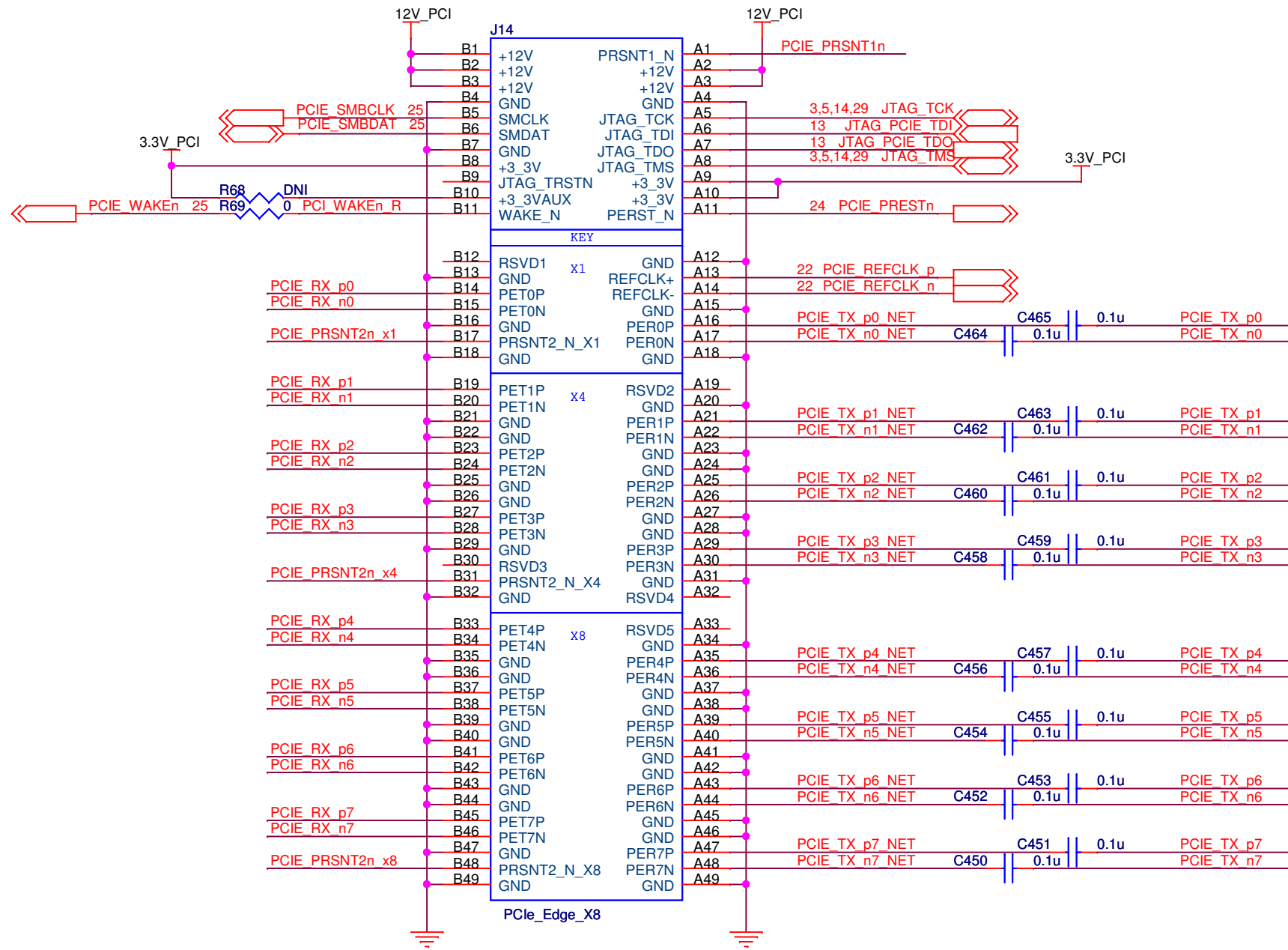
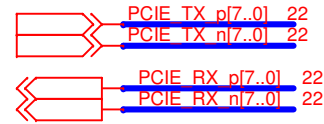

Copyright (c) 2009 Altera Corporation. All Rights Reserved.

Title		
Arria II GX FPGA Development Kit Board		
Size	Document Number	Rev
B	150-0320801-C1 (6XX-40784R)	C
Date:	Friday, August 07, 2009	Sheet 12 of 29

JTAG Control & Setting

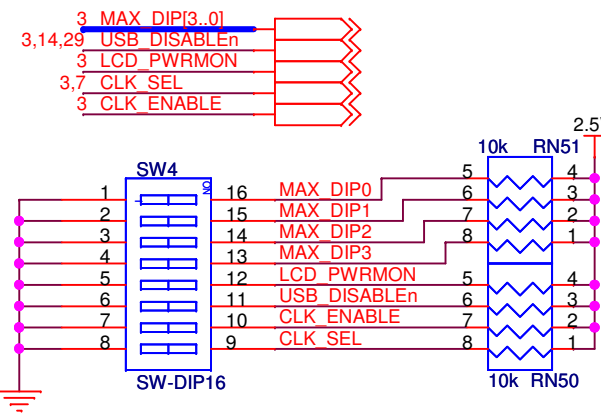
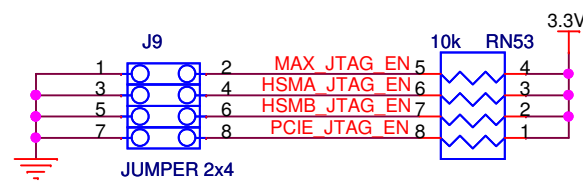
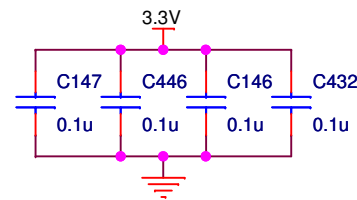
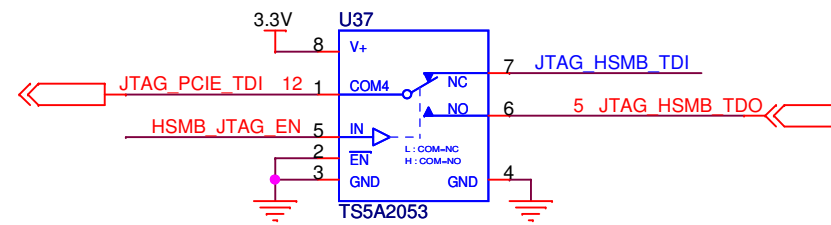
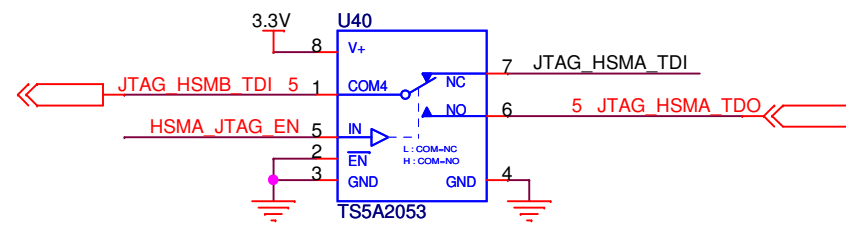
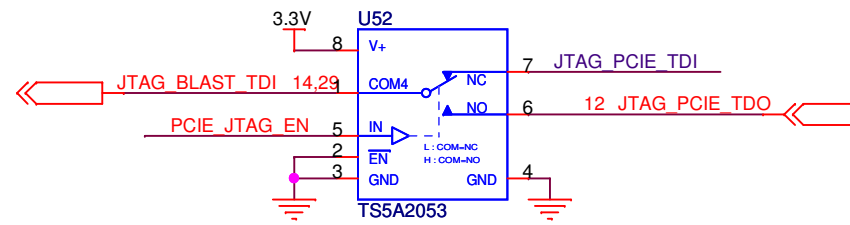
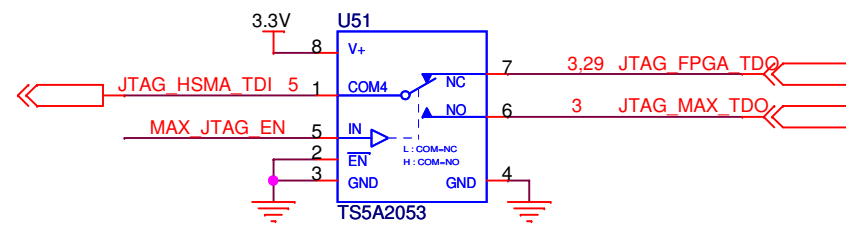

Copyright (c) 2009 Altera Corporation. All Rights Reserved.

Title		
Arria II GX FPGA Development Kit Board		
Size	Document Number	Rev
B	150-0320801-C1 (6XX-40784R)	C
Date:	Friday, August 07, 2009	Sheet 13 of 29

USB Blaster

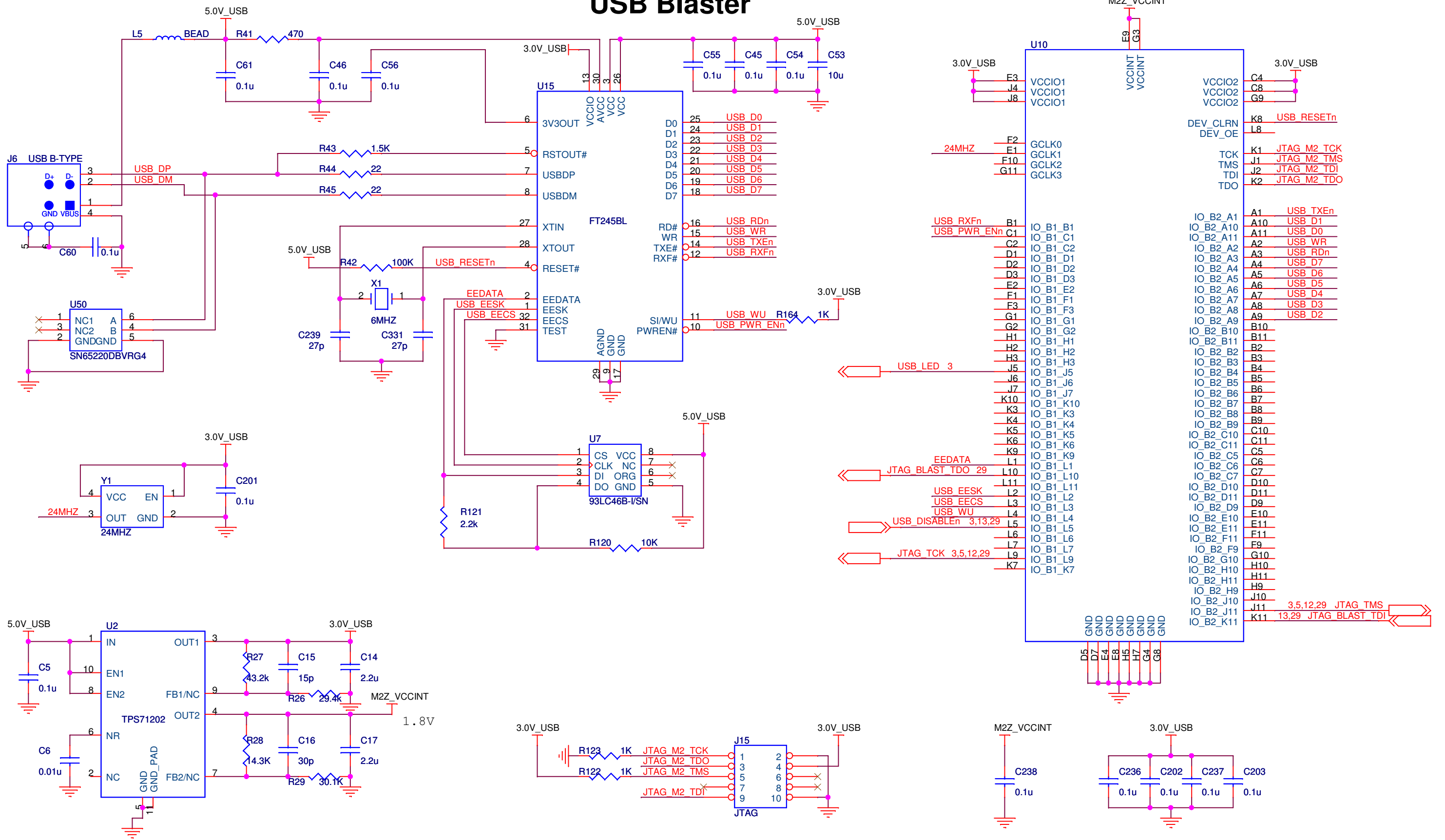

Ethernet

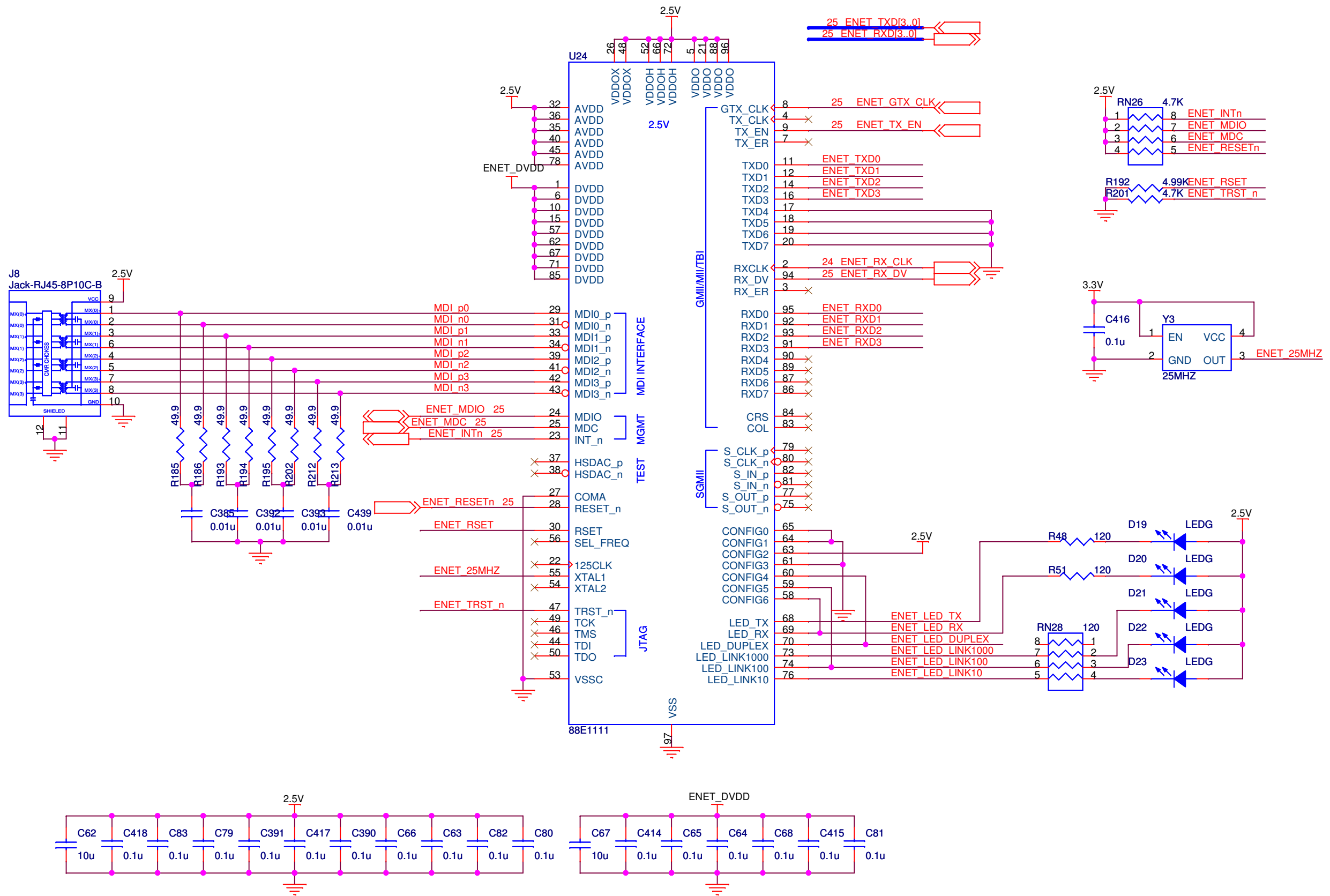

Copyright (c) 2009 Altera Corporation. All Rights Reserved.		
Title Arria II GX FPGA Development Kit Board		
Size B	Document Number 150-0320801-C1 (6XX-40784R)	Rev C
Date: Friday, August 07, 2009	Sheet 15 of 29	

Power Monitor

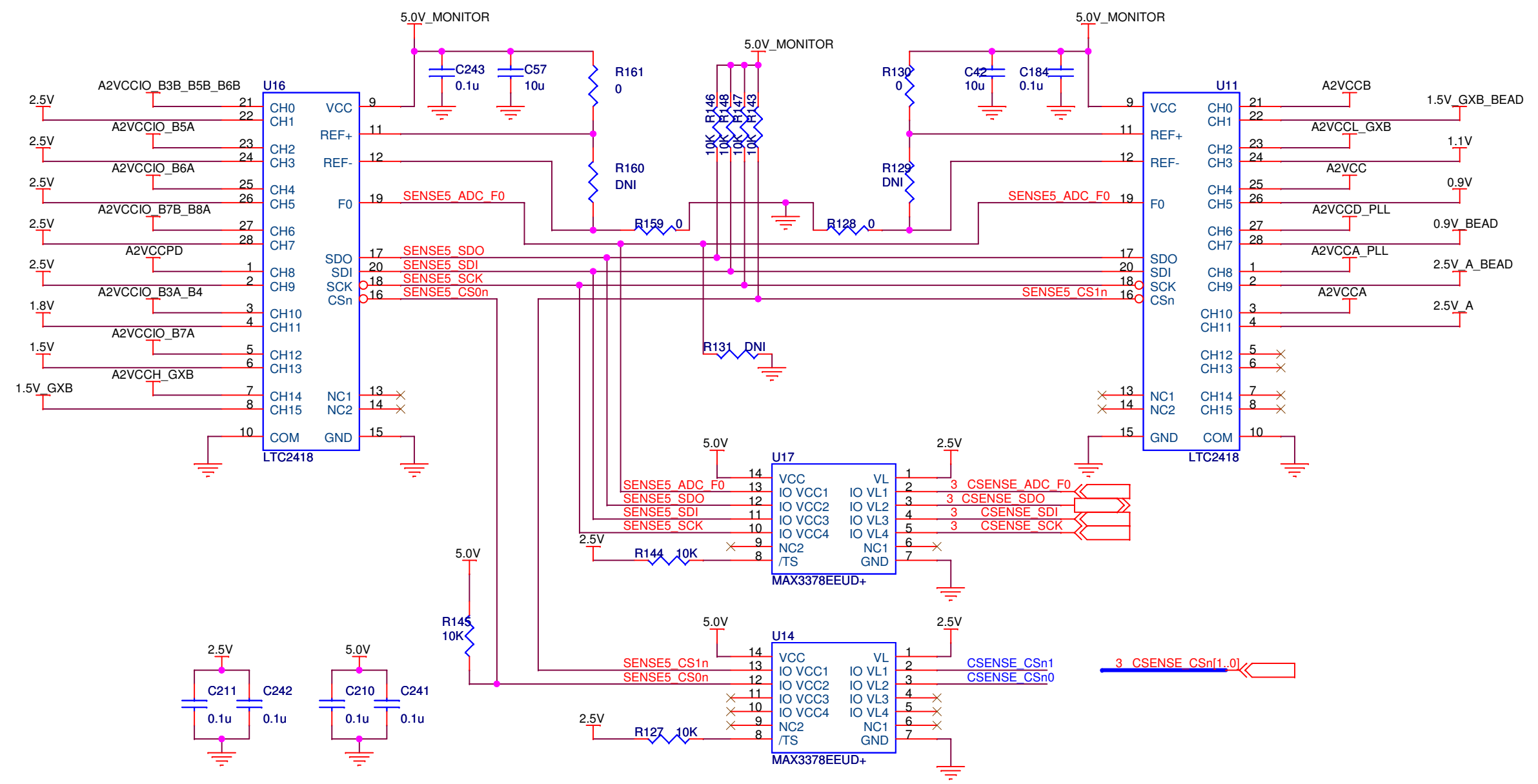

1.1V, 1.0V, VTT & VREF

DDR2 VTT, VREF

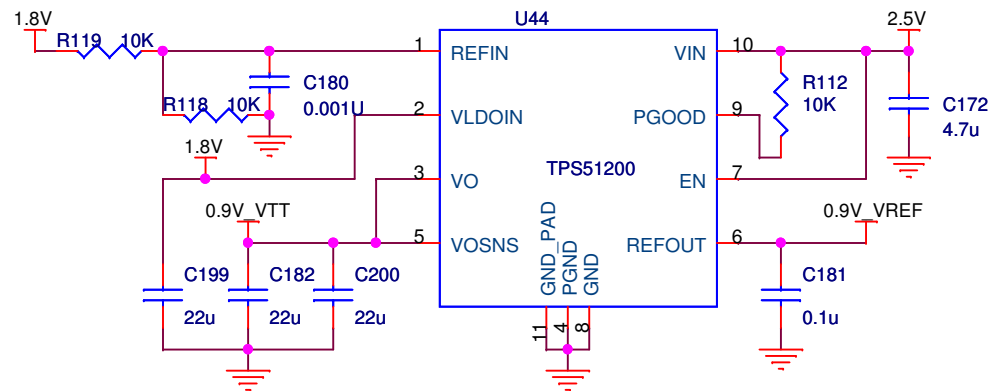

1.1V/500mA

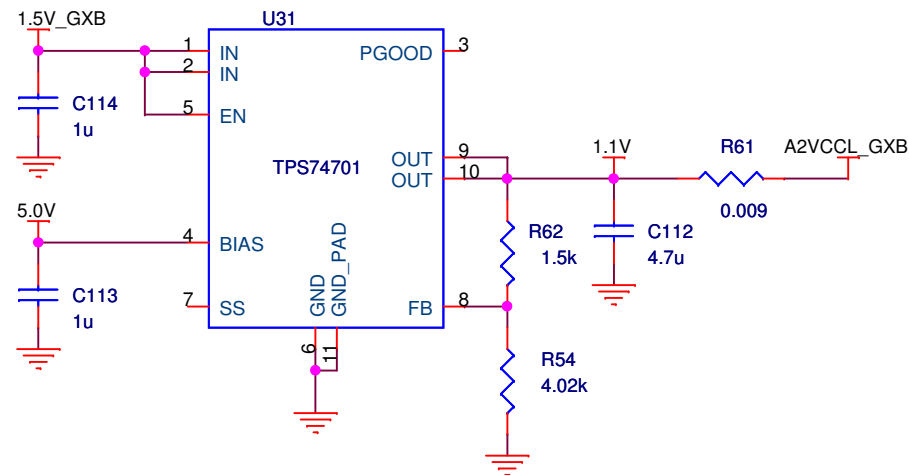

DDR3 VTT, VREF

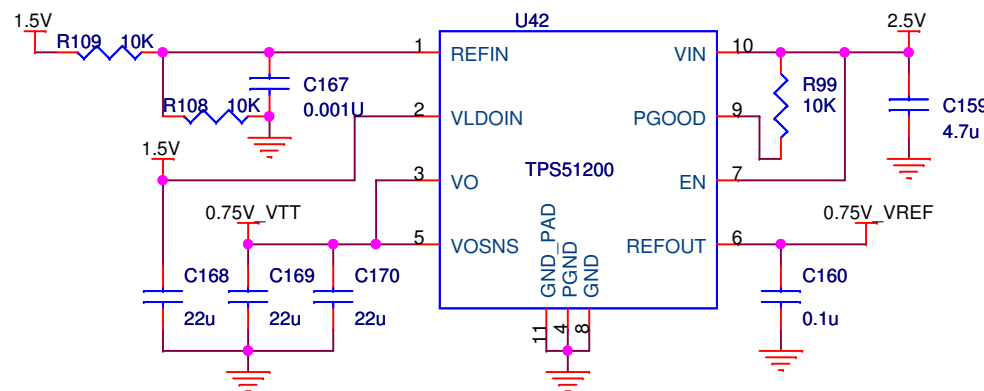

1.0V/500mA

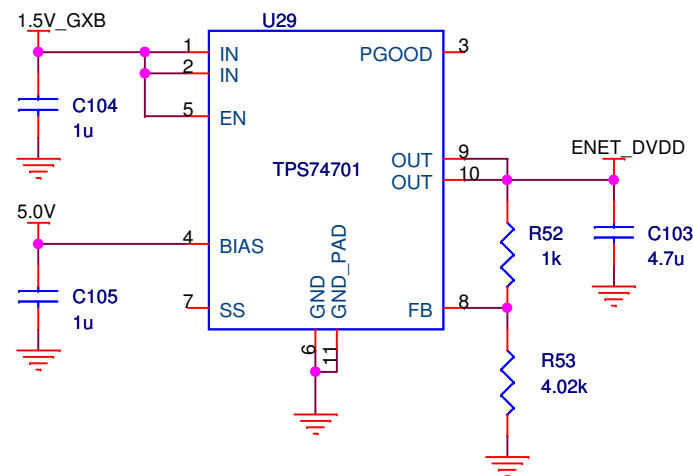

Copyright (c) 2009 Altera Corporation. All Rights Reserved.		
Title Arria II GX FPGA Development Kit Board		
Size B	Document Number 150-0320801-C1 (6XX-40784R)	Rev C
Date: Friday, August 07, 2009	Sheet 17 of 29	

2.5V, 1.8V & 1.5V

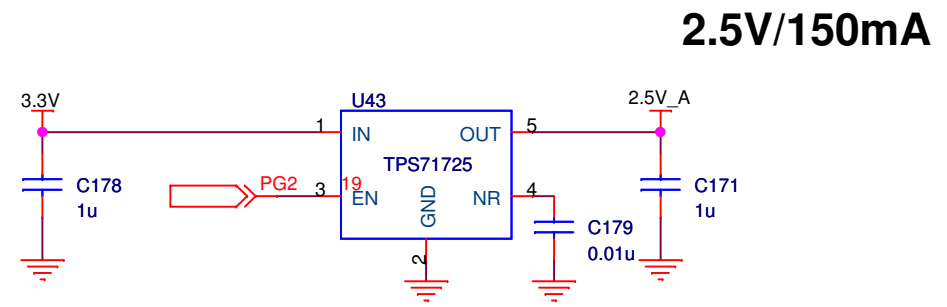
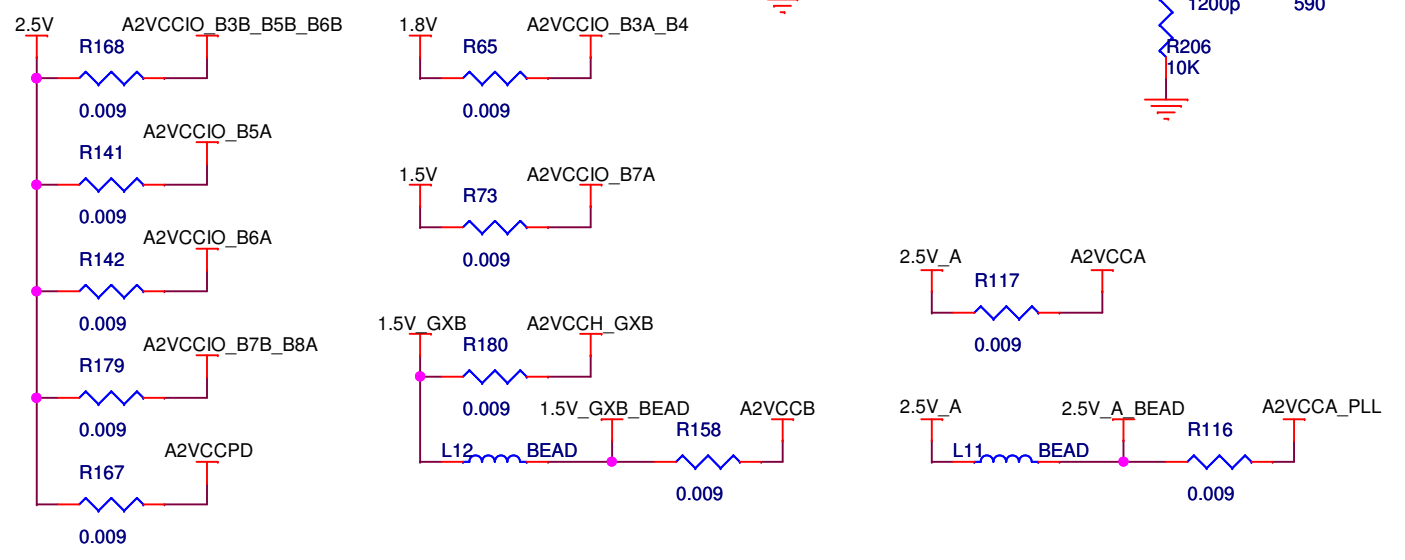
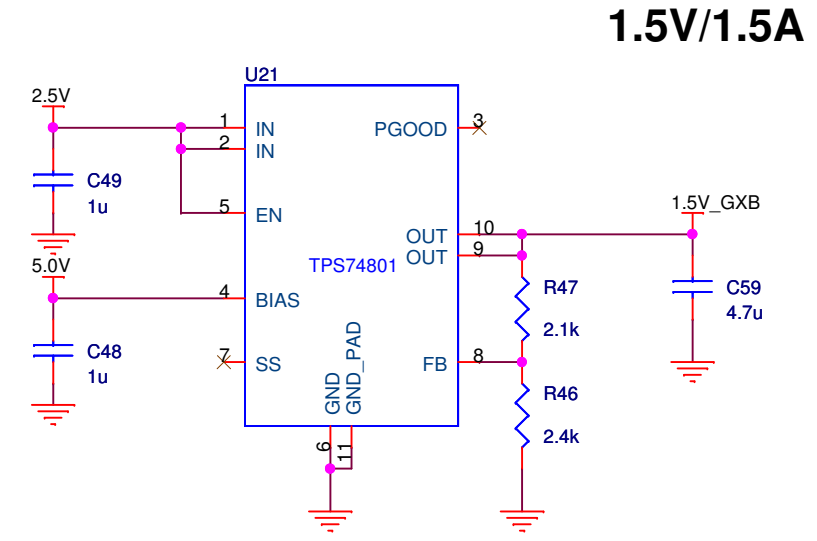
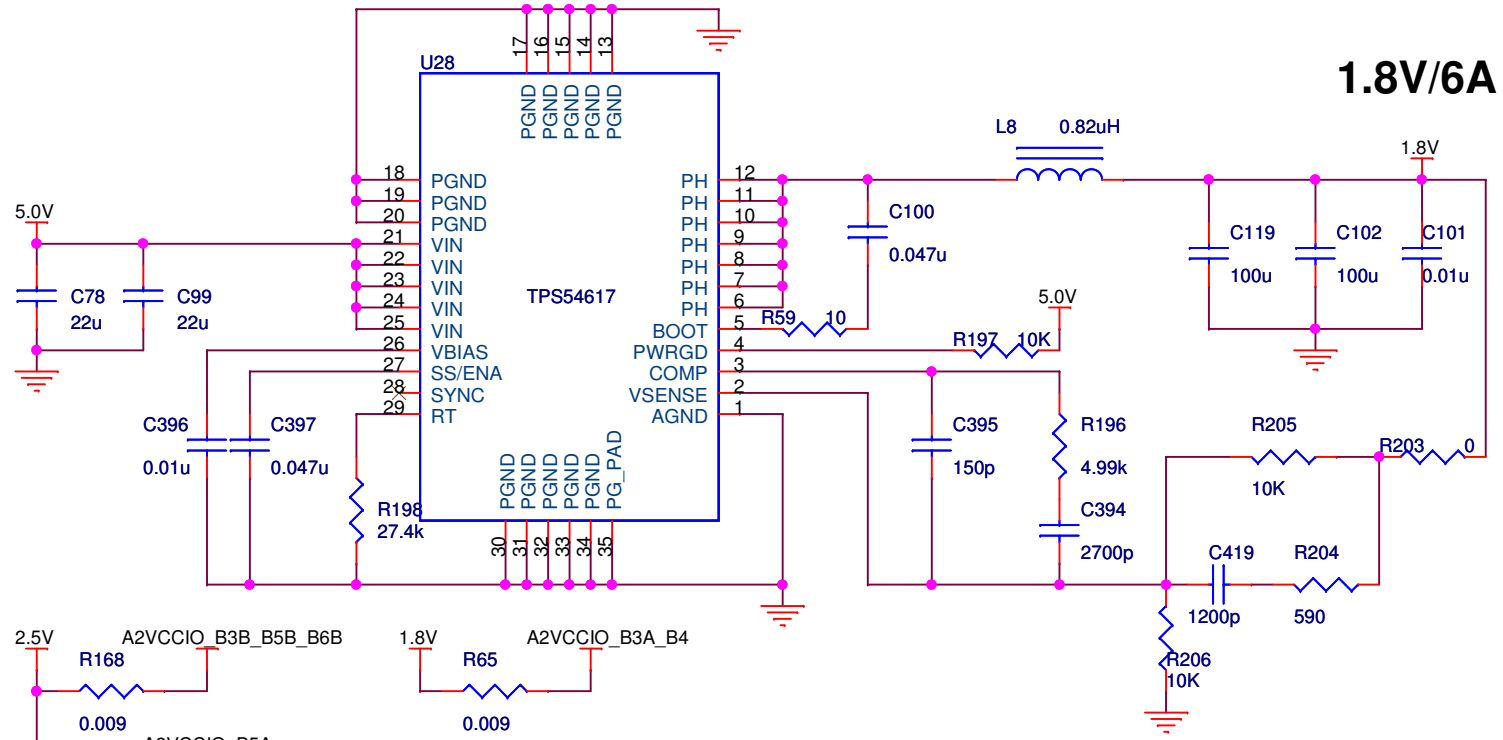
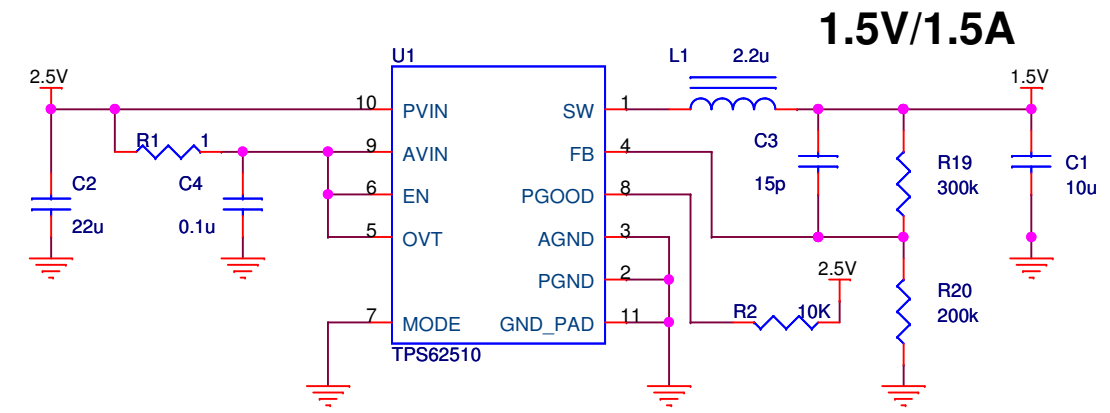
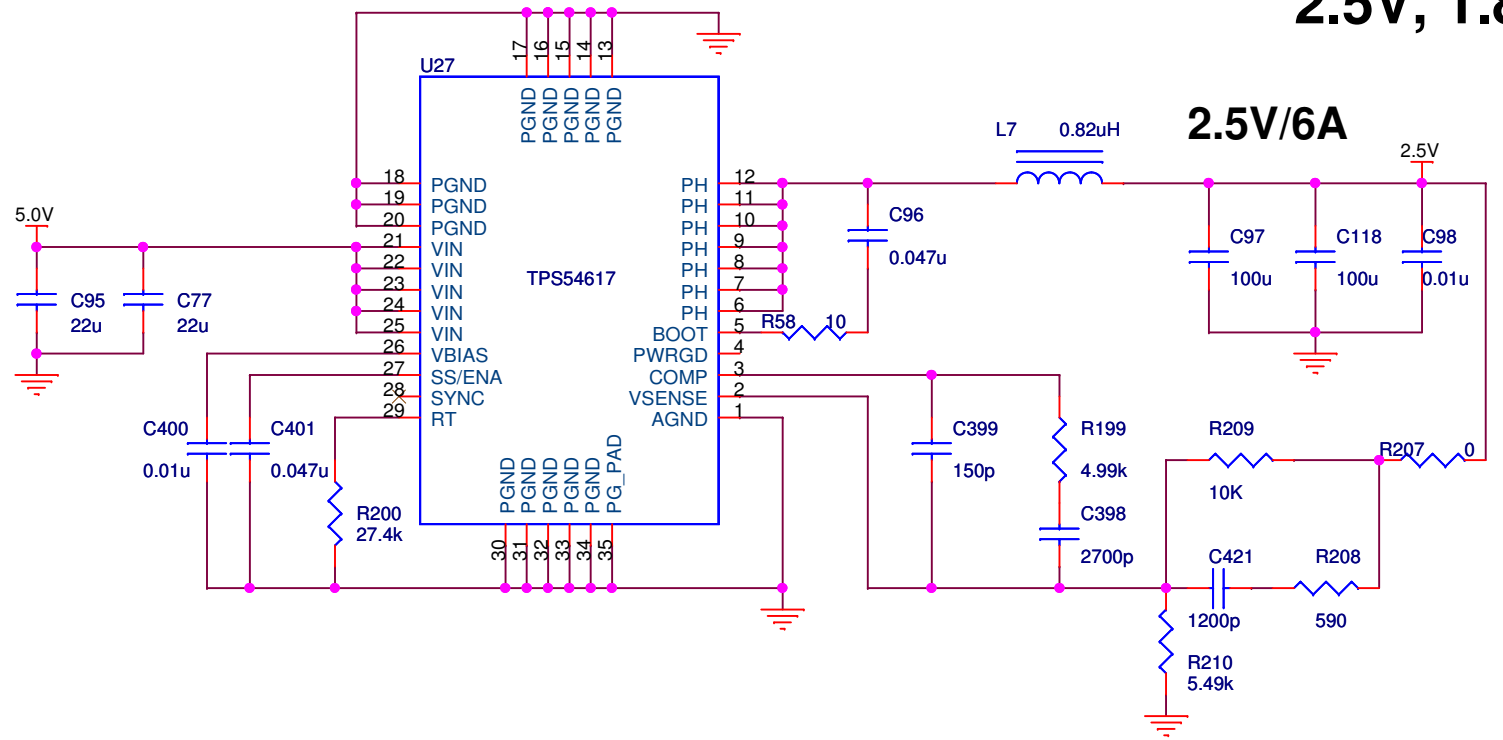

Copyright (c) 2009 Altera Corporation. All Rights Reserved.		
Title Arria II GX FPGA Development Kit Board		
Size B	Document Number 150-0320801-C1 (6XX-40784R)	Rev C
Date: Friday, August 07, 2009	Sheet 18 of 29	Page 1

5V & 0.9V Dual Output

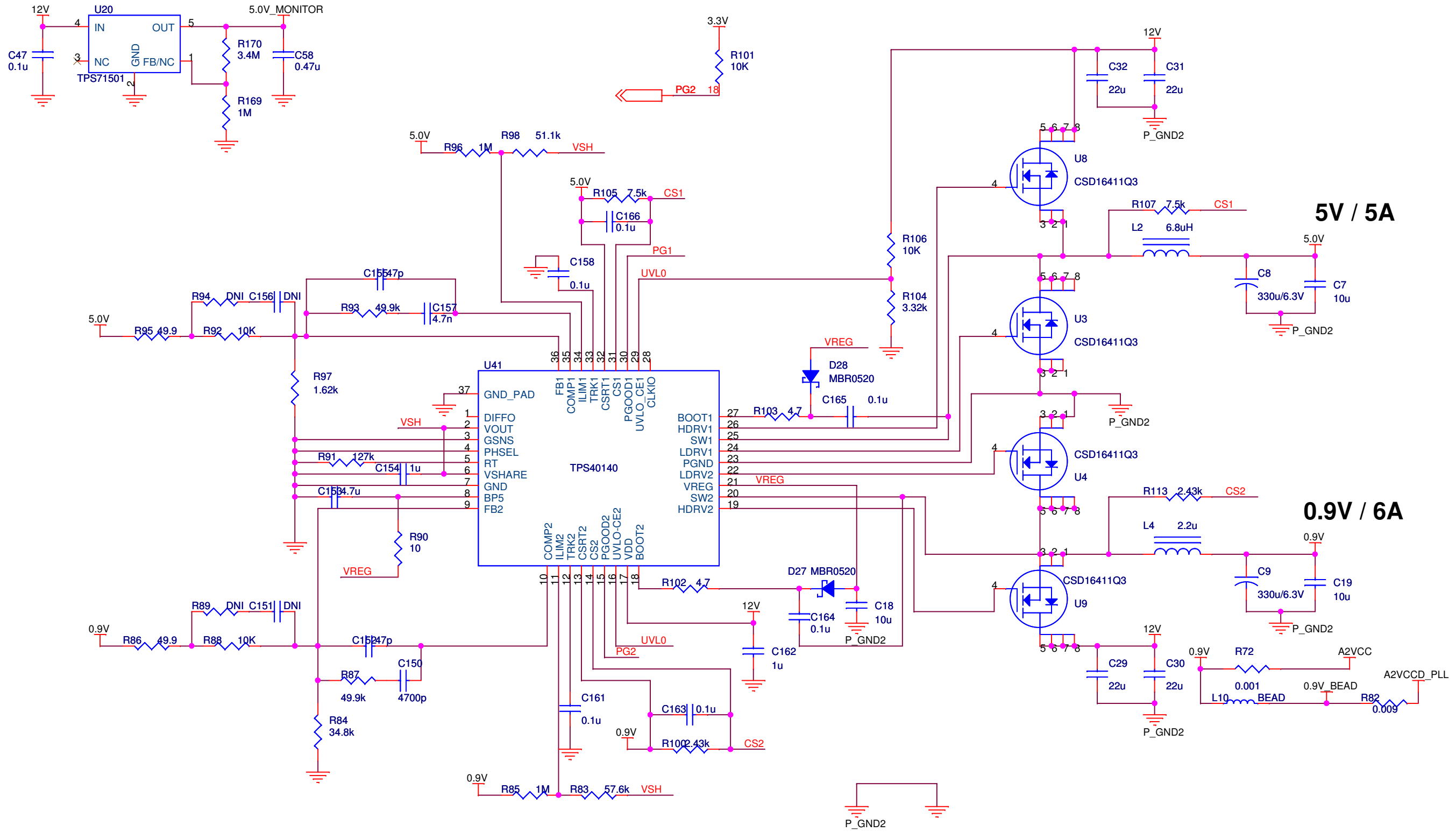

Copyright (c) 2009 Altera Corporation. All Rights Reserved.		
Title Arria II GX FPGA Development Kit Board		
Size B	Document Number 150-0320801-C1 (6XX-40784R)	Rev C
Date: Monday, August 10, 2009	Sheet 19	of 29

DC IN to 12V & 3.3V

14V ~ 20V DC Input

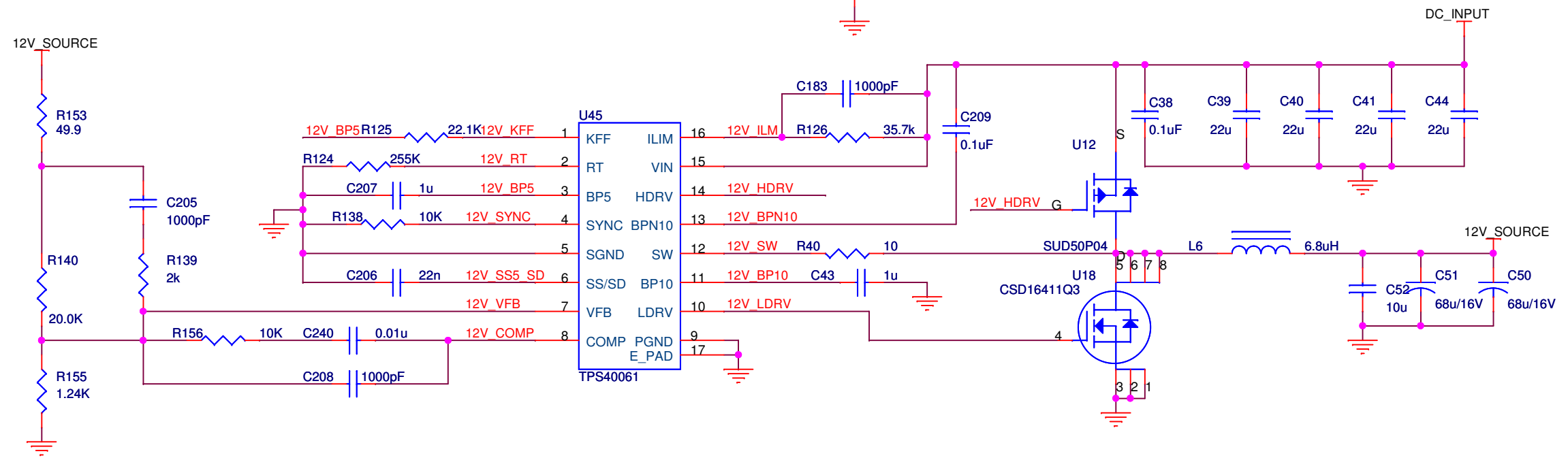
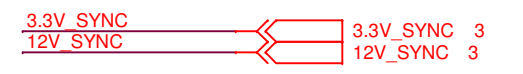
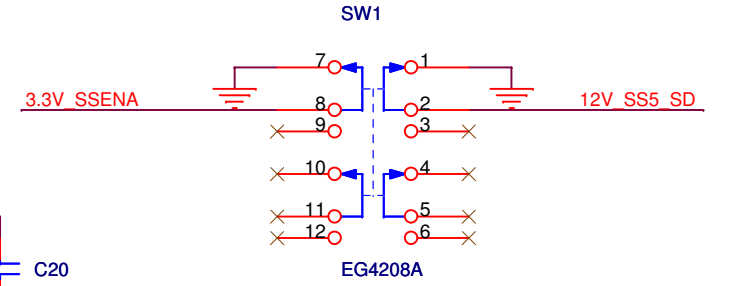
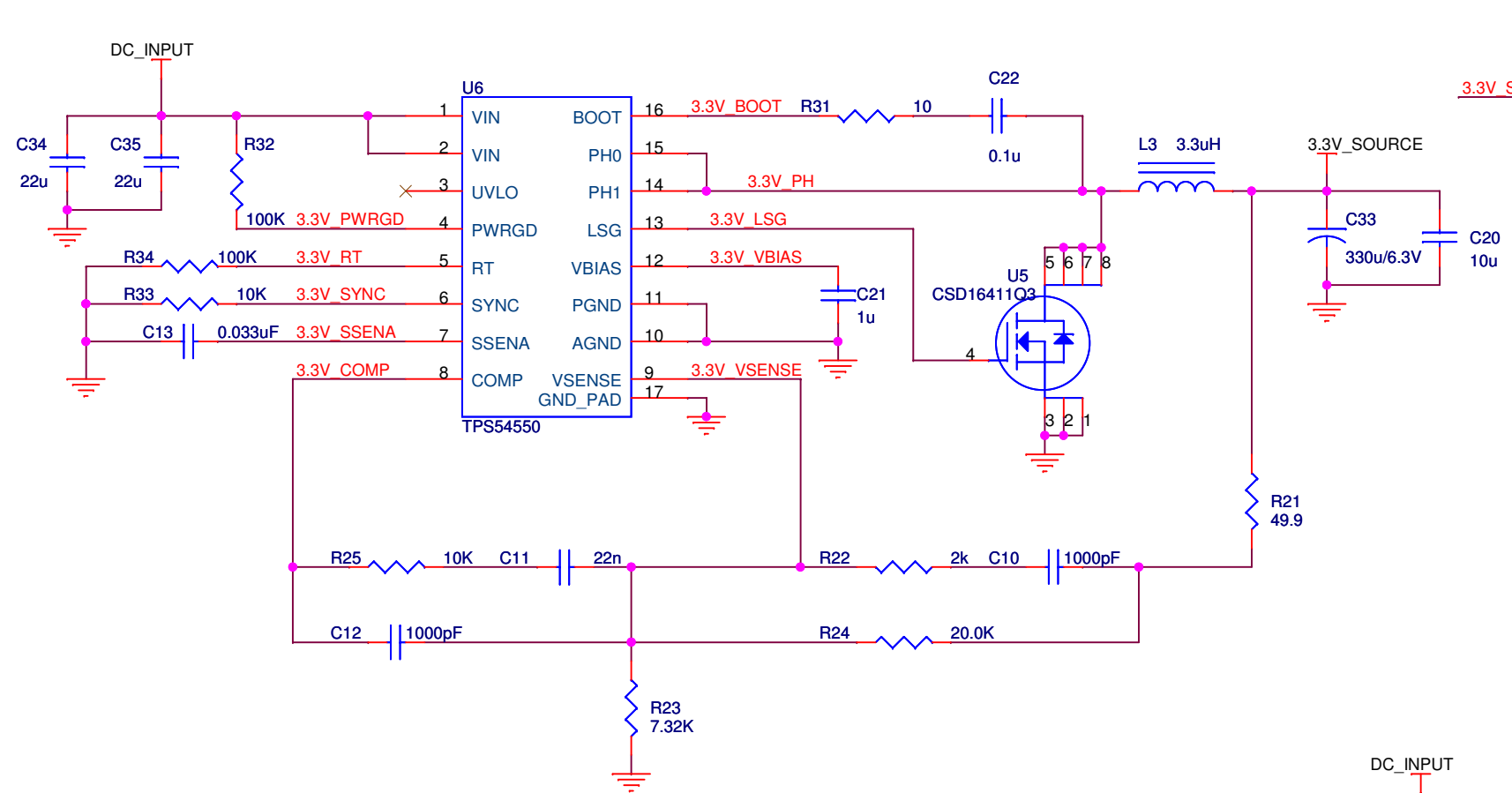
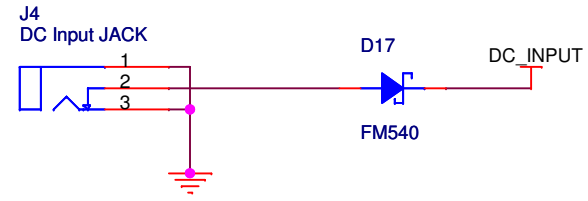

Copyright (c) 2009 Altera Corporation. All Rights Reserved.		
Title Arria II GX FPGA Development Kit Board		
Size B	Document Number 150-0320801-C1 (6XX-40784R)	Rev C
Date: Friday, August 07, 2009	Sheet 20	of 29

Power MUX

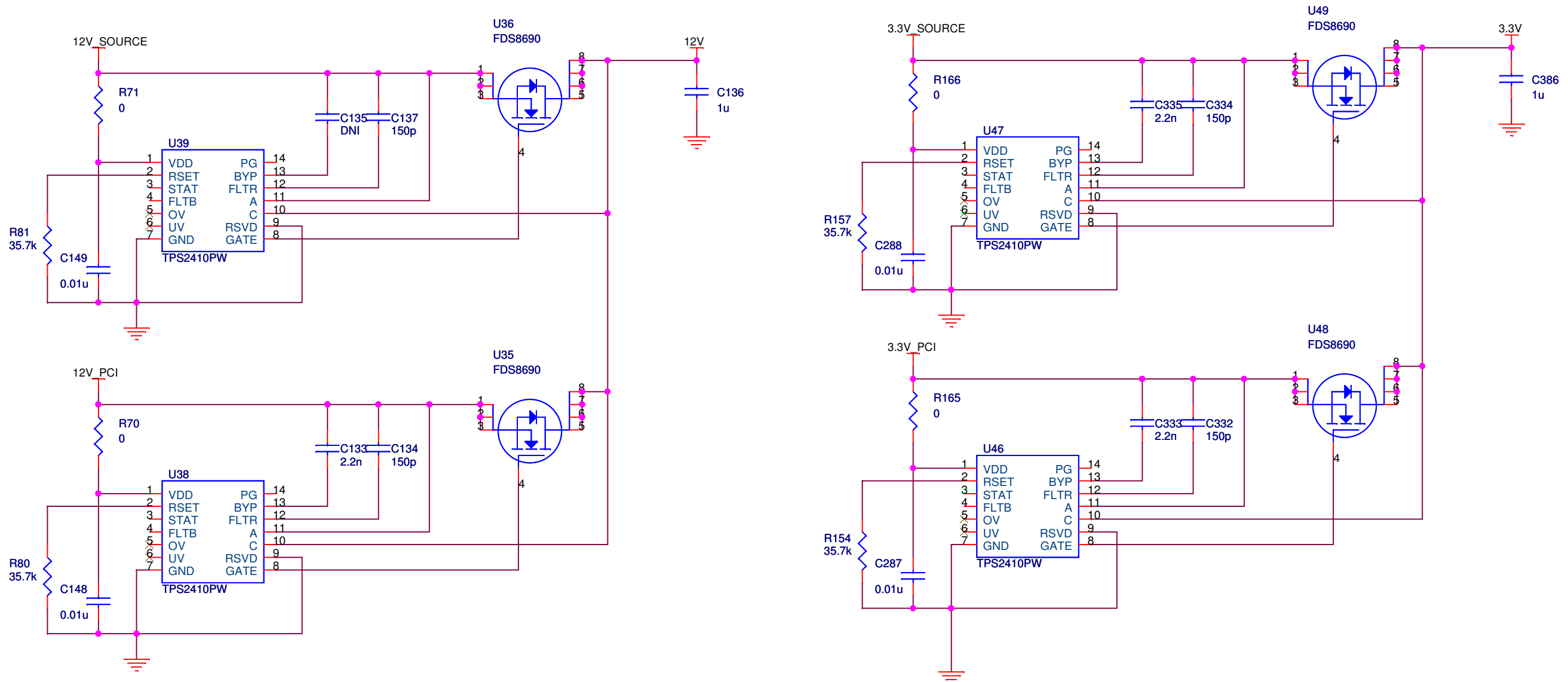

BANK QL

U19A

Arria II GX Bank QL
EP2AGX260 (EP2AGX125)

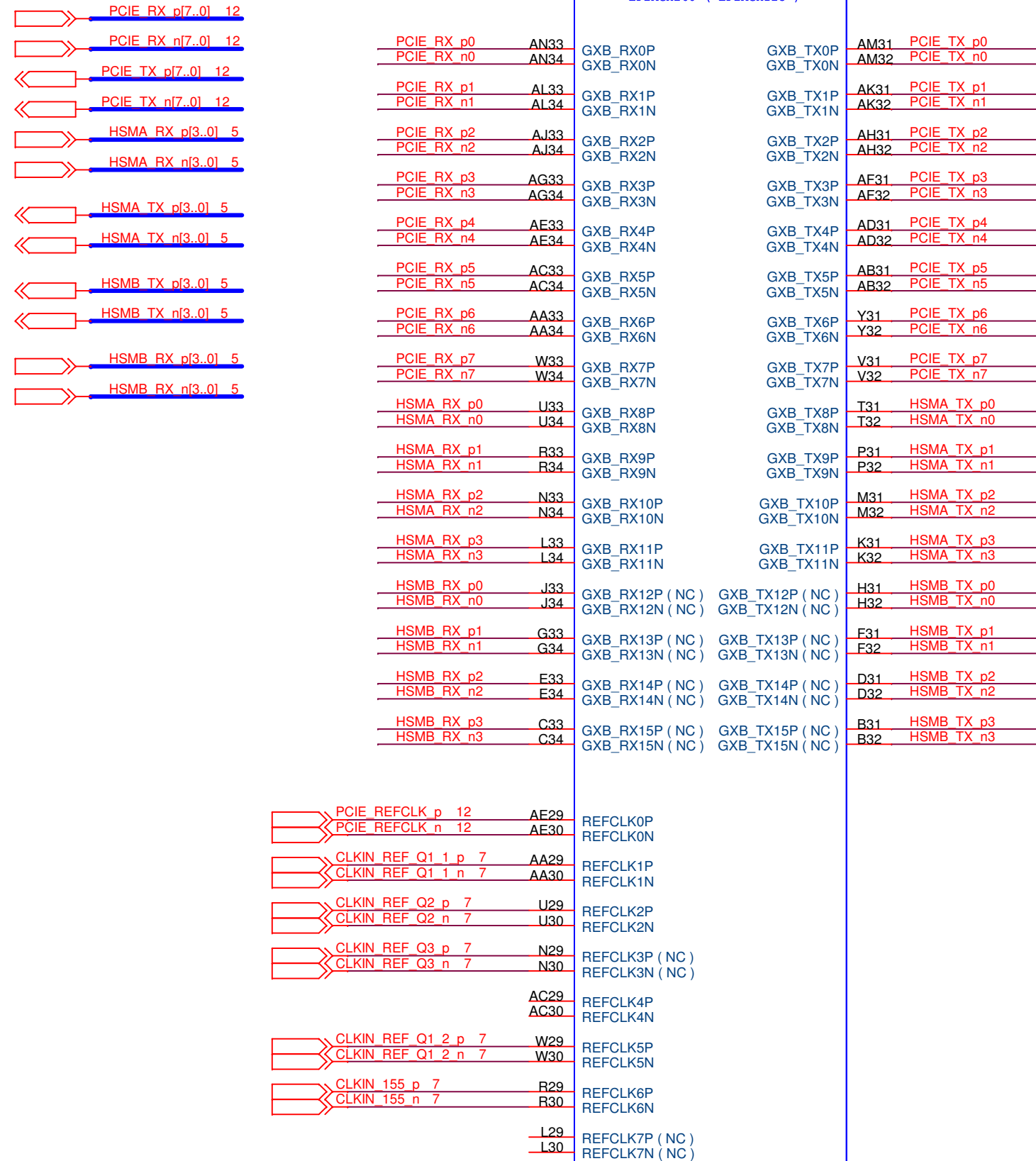

EP2AGX125F1152

Copyright (c) 2009 Altera Corporation. All Rights Reserved.		
Title Arria II GX FPGA Development Kit Board		
Size B	Document Number 150-0320801-C1 (6XX-40784R)	Rev C
Date: Monday, August 10, 2009	Sheet 22 of 29	

BANK5 & BANK6

5 HSMA RX D p[16..0] ←
5 HSMA RX D n[16..0] ←

5 HSMA CLKOUT p[2..1] →
5 HSMA CLKOUT n[2..1] →

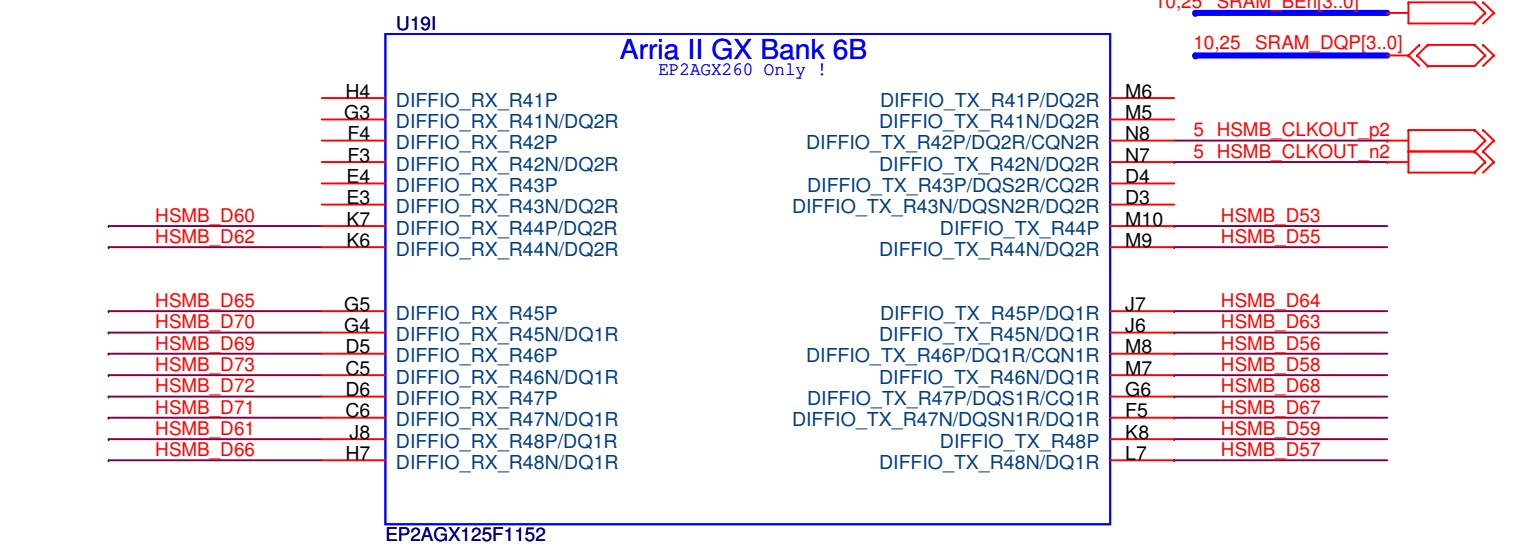
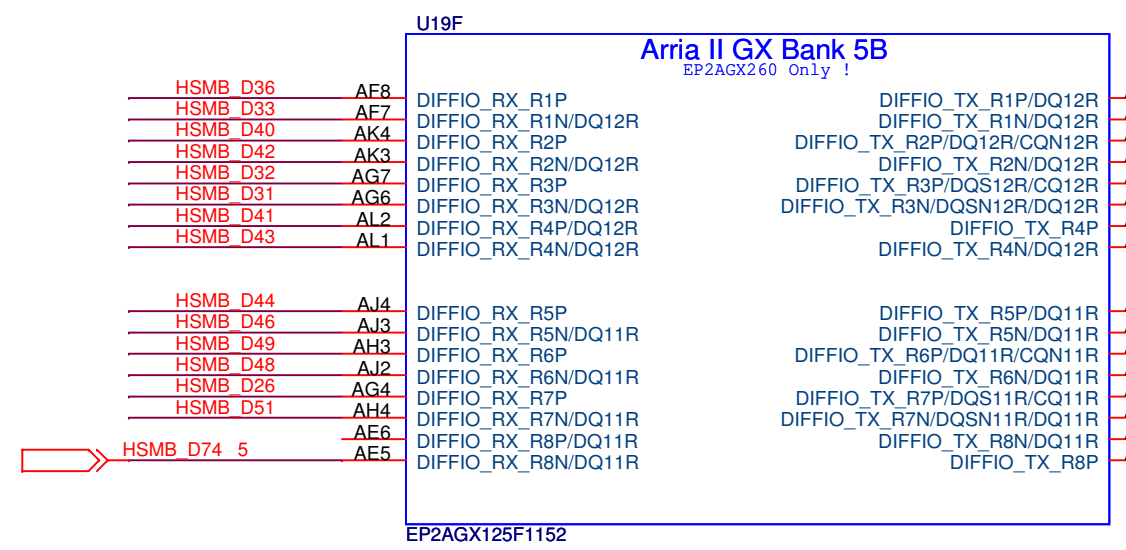
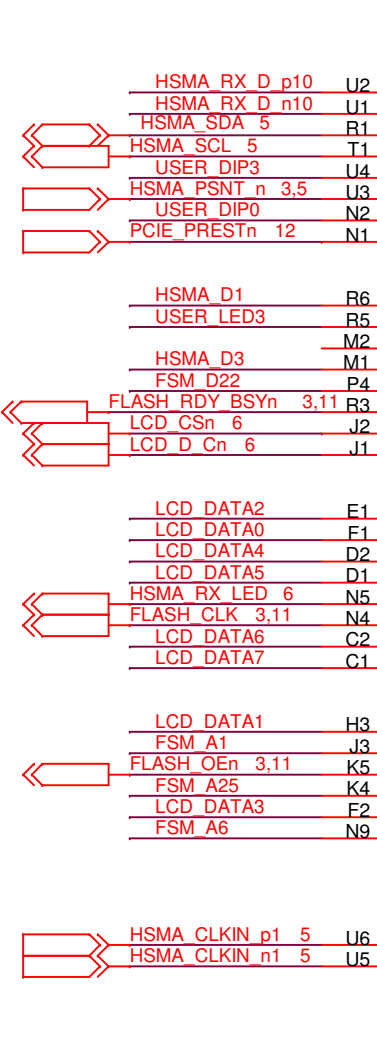
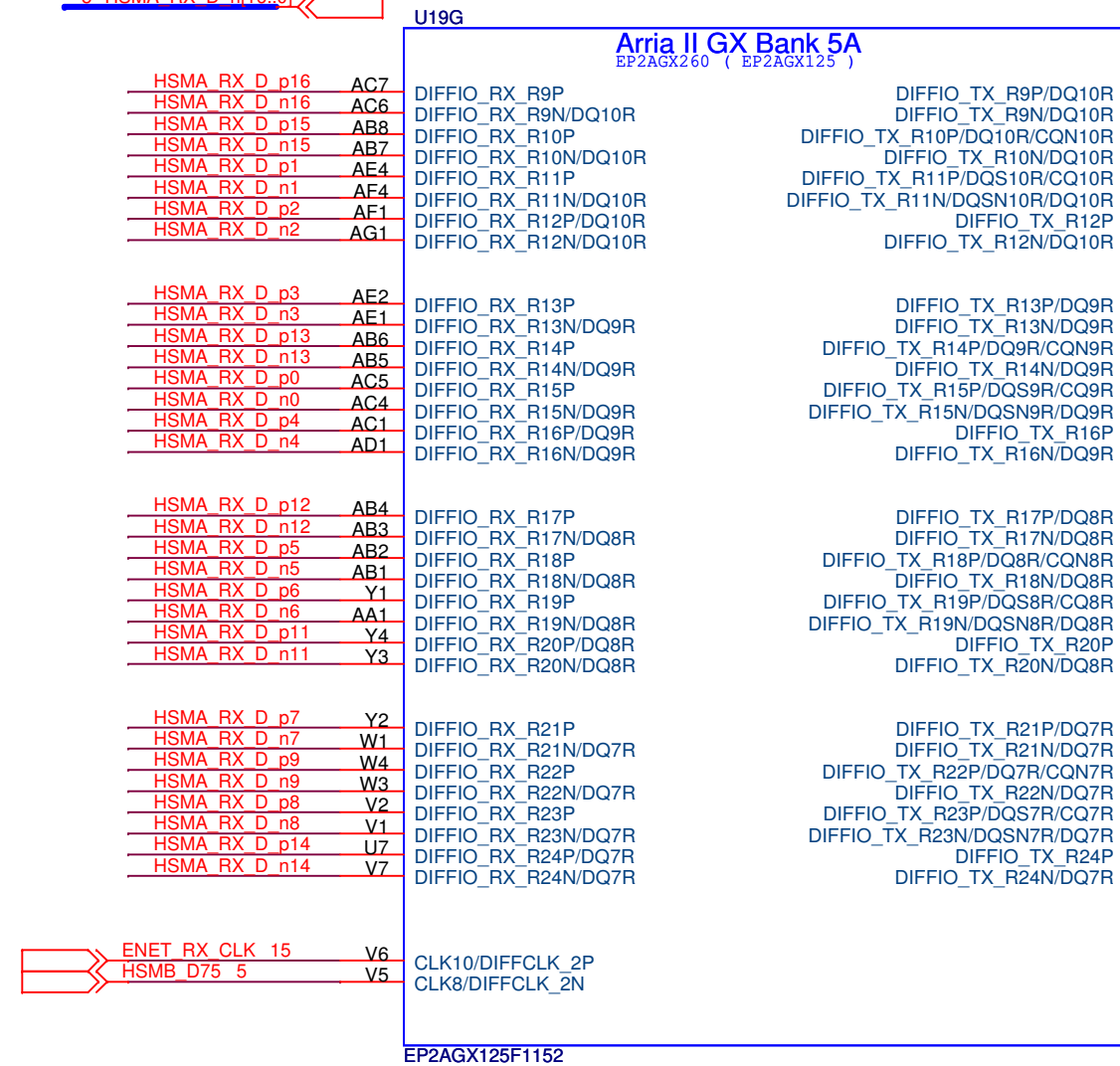

BANK7 & BANK8

U19K

Arria II GX Bank 7A

EP2AGX260 (EP2AGX125)

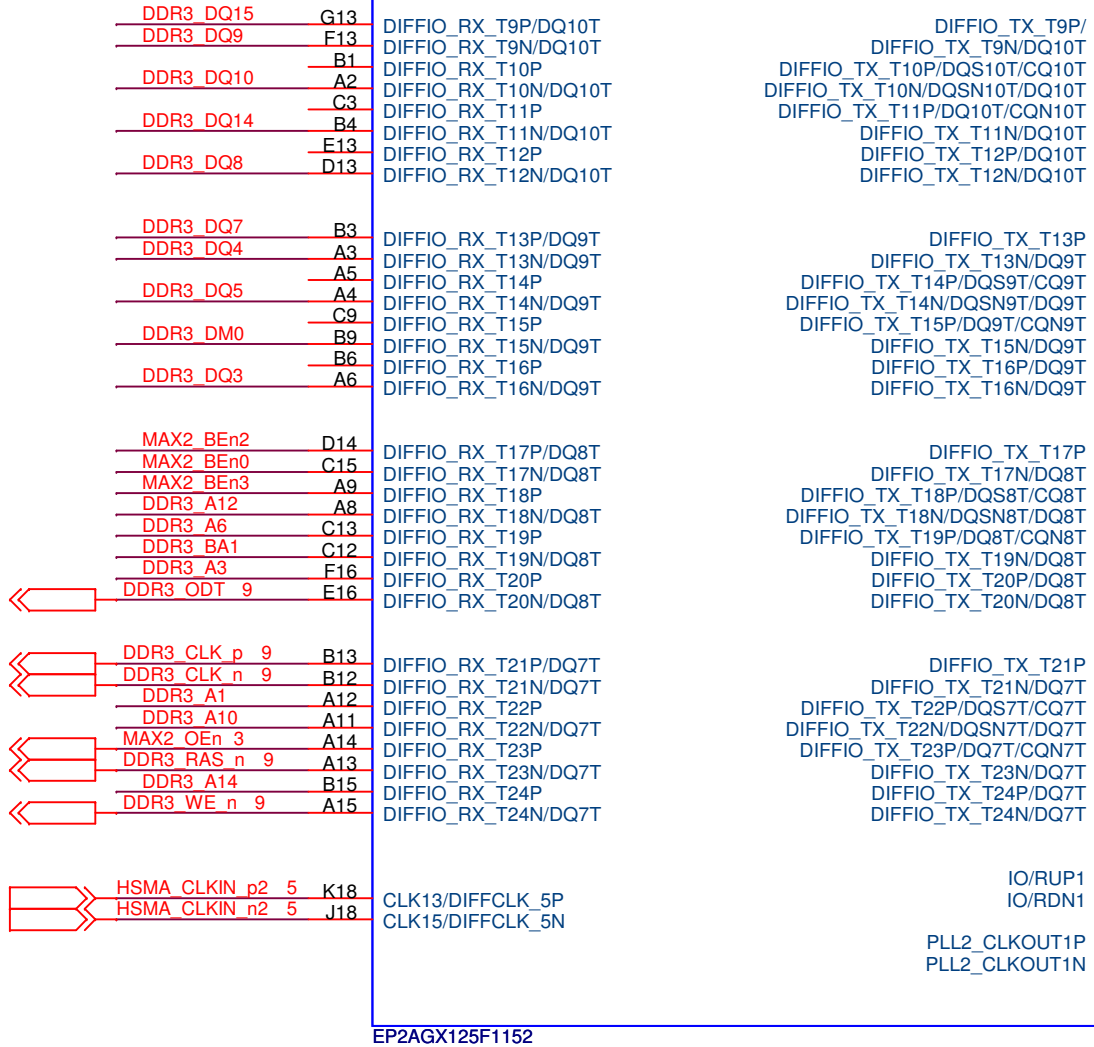

EP2AGX125F1152

U19L

Arria II GX Bank 8A

EP2AGX260 (EP2AGX125)

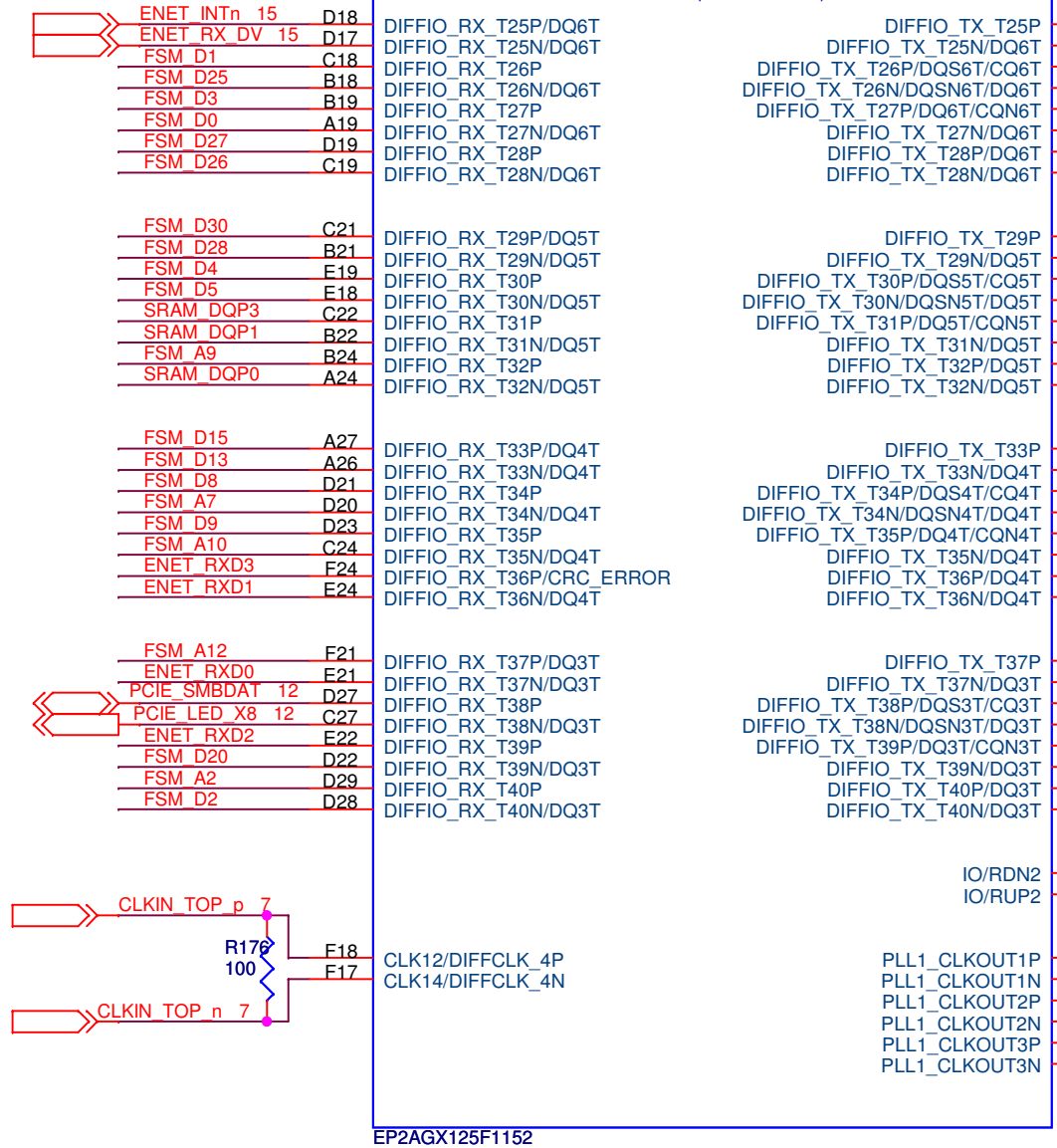

EP2AGX125F1152

U19J

Arria II GX Bank 7B

EP2AGX260 (EP2AGX125)

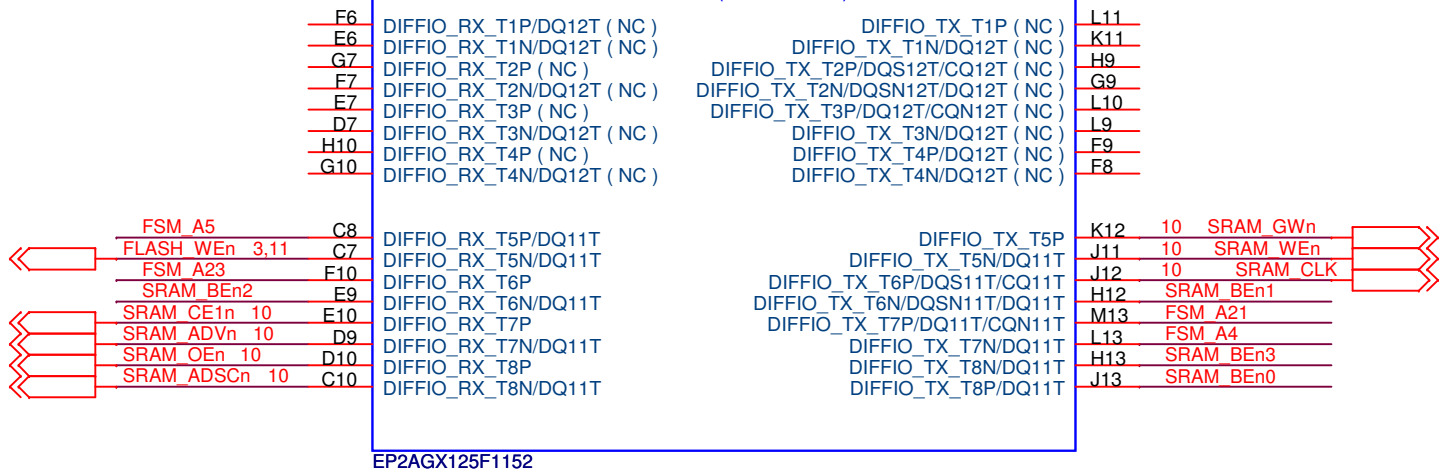

EP2AGX125F1152

U19M

Arria II GX Bank 8B

EP2AGX260 Only !

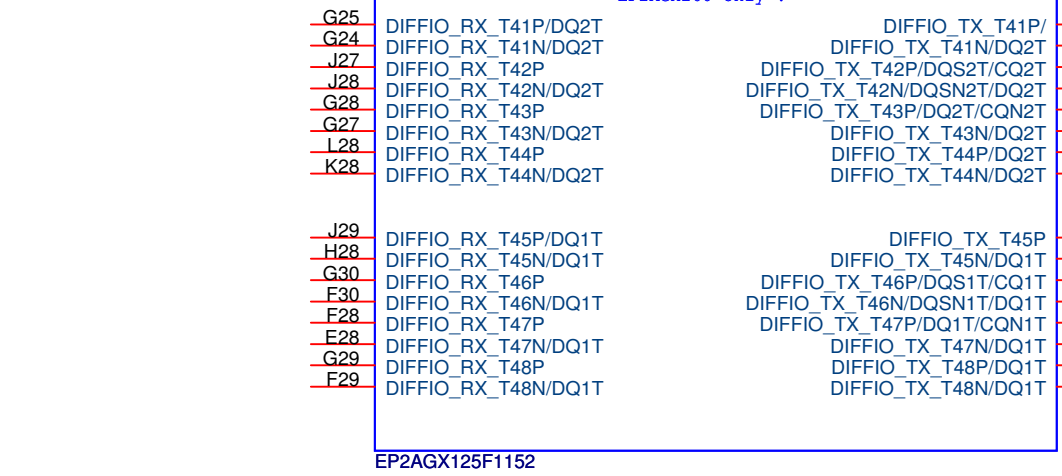

EP2AGX125F1152

Copyright (c) 2009 Altera Corporation. All Rights Reserved.

Arria II GX FPGA Development Kit Board

Size	Document Number	Rev
B	150-0320801-C1 (6XX-40784R)	C
Date:	Monday, August 10, 2009	Sheet 25 of 29

FPGA Power

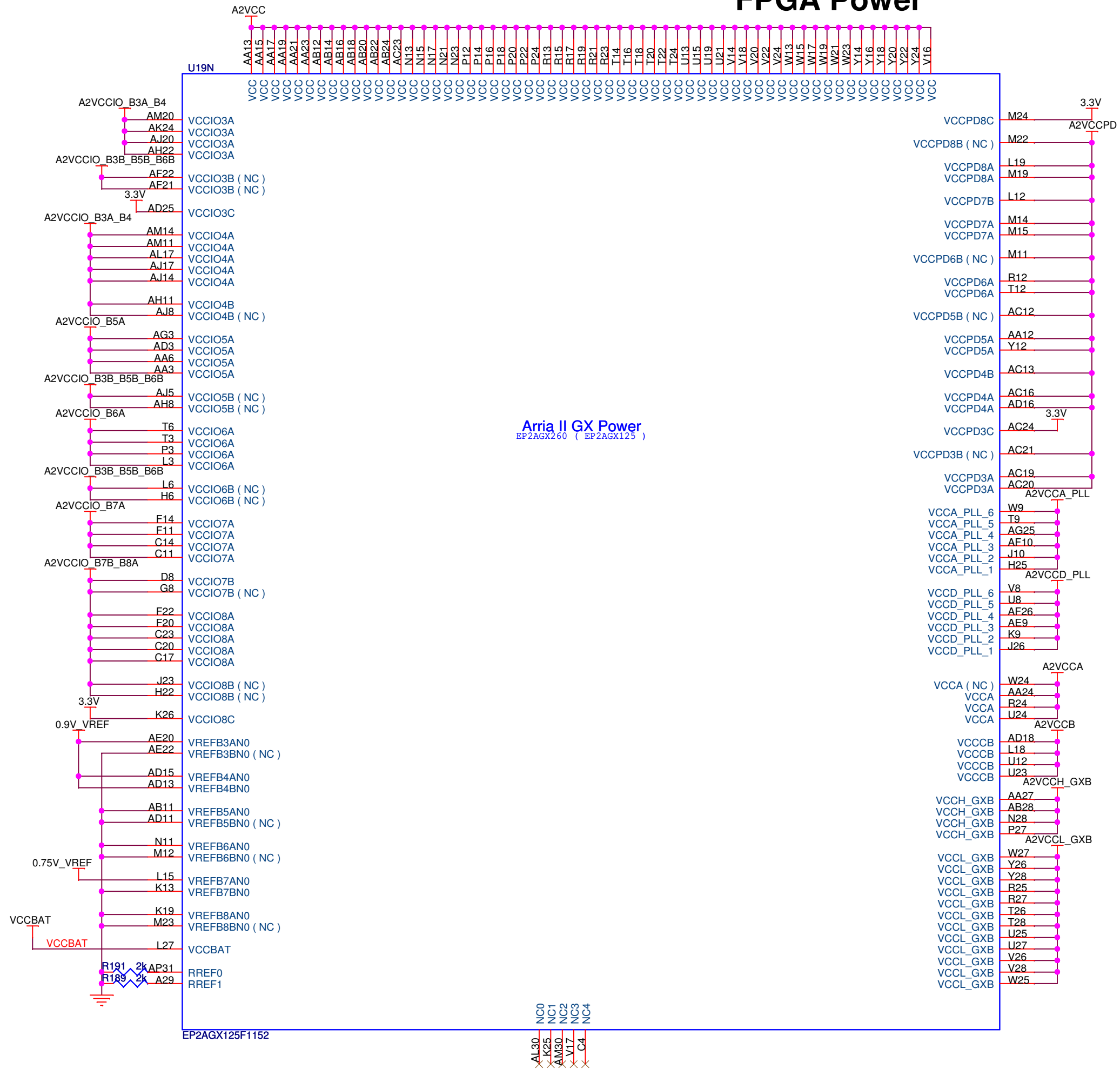

Copyright (c) 2009 Altera Corporation. All Rights Reserved.		
Title Arria II GX FPGA Development Kit Board		
Size B	Document Number 150-0320801-C1 (6XX-40784R)	Rev C
Date: Monday, August 10, 2009	Sheet 26	of 29

FPGA Ground



Copyright (c) 2009 Altera Corporation. All Rights Reserved.		
Title Arria II GX FPGA Development Kit Board		
Size B	Document Number 150-0320801-C1 (6XX-40784R)	Rev C
Date: Monday, August 10, 2009	Sheet 27	of 29

FPGA Decoupling



FPGA Configuration

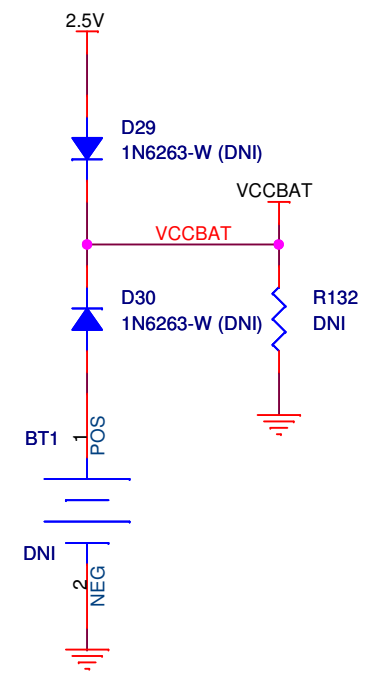
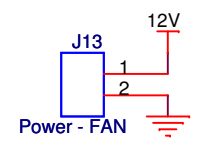
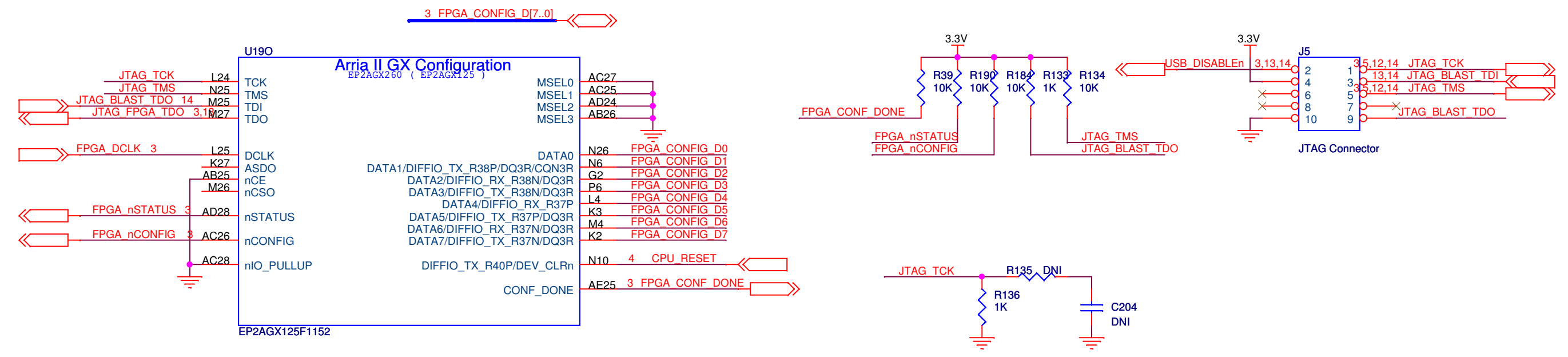

Copyright (c) 2009 Altera Corporation. All Rights Reserved.		
Title Arria II GX FPGA Development Kit Board		
Size B	Document Number 150-0320801-C1 (6XX-40784R)	Rev C
Date: Monday, August 10, 2009	Sheet 29	of 29