

Device Photolithography:

The Step-and-Repeat Camera

By D. S. ALLES, J. W. ELEK, F. L. HOWLAND, B. NEVIS,
R. J. NIELSEN, W. A. SCHLEGEL, J. G. SKINNER
and C. E. STOUT, JR.

(Manuscript received July 10, 1970)

We discuss in this paper the design of a new high-precision step-and-repeat camera with respect to its optics, mechanical design, control system, and control computer program. One micrometer images from a 5-mm-square lens field can be placed within $0.12\ \mu\text{m}$ over a $10\text{-cm} \times 10\text{-cm}$ area on photographic glass plate. Features such as, image plane control, interferometric metering, and automatic reticle pattern alignment, are used to accomplish these objectives. The control computer with CRT message displays for the operator result in an efficient operator-machine interaction.

1. INTRODUCTION

In previous papers, the equipment for converting the designer's topography into a primary pattern and the subsequent reduction in size have been described. For thin film integrated circuits, the output of the reduction camera is the master mask from which working copies can be produced for use in fabricating the device. For semiconductor devices, however, the output of the reduction camera is ten times larger than the required final image size. Thus, a further reduction in size is required. In addition, a mask for a semiconductor device consists of an array of images that are precisely placed on the master mask. Thus, the step-and-repeat camera is both a reduction camera and, through the use of a moving X - Y stage, permits the placement of images in an array covering the desired field of the mask.

1.1 Requirements

If a final mask consisted of a single image and if only one mask level were required to produce a functioning semiconductor device, the step-and-repeat camera would be a simple tool to design and build. In

actually, a mask is complex. As shown in Fig. 1, a mask consists of an array of images, the majority of which are the primary images required for fabricating the specific device. In addition to the primary images, a wide range of test, secondary continuity and alignment images used during the fabrication process are included. Thus, before a mask can be produced on the step-and-repeat camera, all of the reticles containing the required images must be available.

In fabricating a semiconductor device, multiple masks are needed, each corresponding to a specific processing step. Typically, nine to twelve distinct levels are required for integrated circuits. For the mask set to be useful, the images in the various levels must be in registration from one level to the next. As device features have become smaller, the requirement for registration of the mask images from level to level

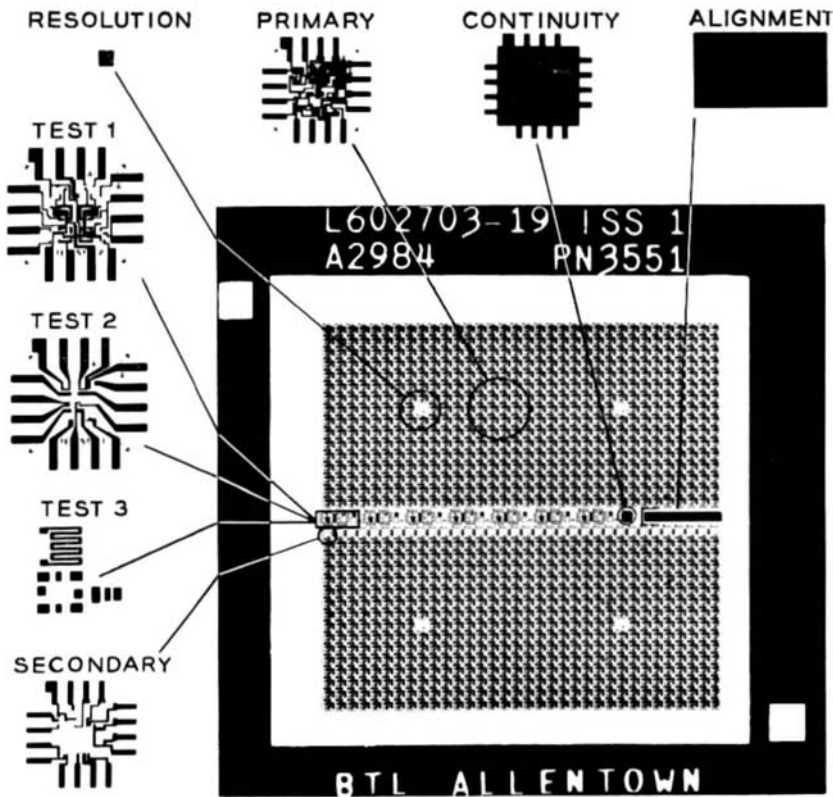

Fig. 1—Typical integrated-circuit photo mask and its various patterns.

has become more stringent. In addition, certain classes of devices such as the silicon target for the *Picturephone*® camera tube, though basically simple, must be produced by field-butting techniques that require the step-and-repeat camera to provide precise image placement.

The design objectives for the step-and-repeat camera are summarized in Table I. The first three items, resolution, image field size and distortion, are established by the optics of the system. The image placement accuracy and array size, items 4 and 5, are determined by the mechanical stage and the position sensing and control system. The last item, the operating time, is of interest because it relates to the balanced operational capability of the entire mask-making system.

Past experience with step-and-repeat camera operations has revealed that a camera capable of the performance listed in Table I does not guarantee error-free operation, i.e., high yield. The major cause of low camera output is operator error. Thus considerable attention has been given to eliminating, where possible, operator tasks that have been shown to result in errors.

1.2 General Description

The step-and-repeat camera described in the following sections, is a single-head, ten-times-reduction camera mounted over a moving X-Y stage supported and guided by air bearings. Table-position is determined using double-pass interferometers for both X and Y axes. The physical arrangement of the completely assembled camera is shown in Fig. 2. The physical size is approximately 1.2 m in width and depth and 1.5 m high. The camera and stage systems are on the operator's left; operator displays and controls are on his right.

The glass photographic plate on which the mask will be made is positioned in a fixture on the camera's stage. The reticle whose pattern will be projected onto the photographic plate is located below the hinged cover which supports the flash lamp and condenser housing. The camera's status and operator instructions are given on the lighted message board and all normal operator controls are provided on the operator keyboard. A more extensive set of controls is available for camera maintenance.

All of the camera functions are controlled and monitored by a computer which is located outside the camera's temperature-controlled clean room. The use of a small computer rather than a hard-wired controller has allowed the camera's operation to be flexible, and provides nearly automatic operation with a minimum of operator intervention.

The mask-making sequence is initiated by the operator's request

TABLE I—DESIGN GOALS FOR THE STEP-AND-REPEAT CAMERA

1. Lens Resolution	1 μm
2. Maximum Image Size	5 mm square
3. Image Distortion	0.1 μm
4. Image-Placement Accuracy	0.12 μm
5. Maximum Size of the Array	10 cm
6. Typical Step-and-Repeat Time	1200 s

(at the operator keyboard) for a new job. The computer in turn requests a job from the Mask Shop Information System (MSIS). The list of required reticles and other pertinent information is displayed for the operator on a CRT. The operator loads both the photographic plate and the correct reticle and then commands the camera to continue. The array information is transmitted from the MSIS computer and the pattern is step-and-repeated. When the mask is completed or a new reticle is needed, the operator is alerted by a message on the display board

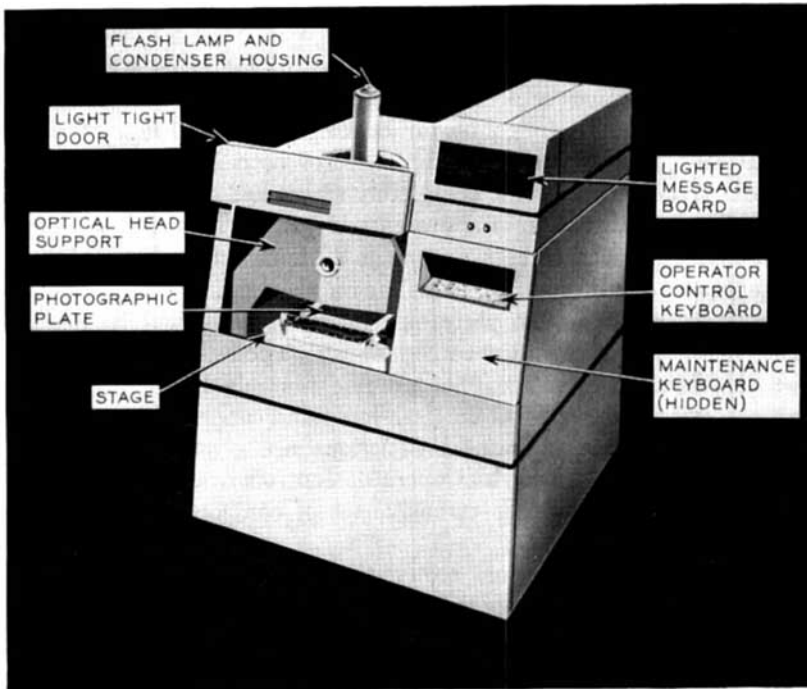

Fig. 2—The step-and-repeat camera.

and by an auditory alarm. Operator errors or equipment malfunctions are also indicated on the message board.

The following discussion of the camera is divided into four major sections: Section II, Optical Head Assembly; Section III, Stage Assembly; Section IV, Control System; and Section V, Program. Although these are discussed separately, the design of all systems, both hardware and software, were developed simultaneously with close collaboration between personnel to assure a smoothly functioning camera design.

II. OPTICAL HEAD ASSEMBLY

2.1 *General Features*

The optical head assembly is a complete unit containing all the optics and electronics necessary to project a pattern on to the mask. The salient features of the optical head are:

- (i) It projects a 5-mm-square image with a line-width capability of $1\ \mu\text{m}$ on photographic emulsion.
- (ii) It can deliver four times the energy needed to expose dyed KHRP plates.
- (iii) It has the power capacity to project six formats per second.
- (iv) Exposures are made while the table is in motion with negligible line-width errors.
- (v) It has a built-in auxillary projection system to facilitate centering the flash-lamp.
- (vi) The reticle is held in place by six pneumatic plungers which operate in a programmed sequence to ensure that it is correctly positioned against its support pads. It is then optically automatically aligned to an accuracy of $\pm 0.25\ \mu\text{m}$, which is equivalent to a positioning accuracy of $\pm 0.025\ \mu\text{m}$ in the image plane.
- (vii) The reticle number is electronically identified after it is aligned.
- (viii) A 5×7 lamp array can be projected through the main projection lens for writing identifying alpha-numeric information on the mask.
- (ix) The main structure is thermally compensated to maintain focus and magnification over a temperature range of $\pm 3^\circ\text{C}$.
- (x) The assembly is "fixed-focus" with no external adjustments.
- (xi) The lens is automatically protected from above by a shutter whenever the reticle is removed.

2.2 *Reticle Format*

The reticle for the step-and-repeat camera is the 4" \times 5" output plate from the 3.5X reduction camera. The reticle format, shown in Fig. 3, has a pattern area of 5.2 cm \times 6.4 cm with the corner bounded by a radius of 3.536 cm. At one end of the format is a secondary information strip containing 42 binary bits each 0.5 mm square. The data recorded in this strip is the drawing number of the reticle pattern.

At the other end of the format are two fiducial marks that are used for automatic-positioning of the reticle when it is mounted in the camera.

2.3 *Projection Lens*

The lens, which was designed and manufactured by Tropel, Inc.,* to Bell Telephone Laboratories specifications, is a nine-element double-Gauss design (See Fig. 4). The object to image distance is 48.37 cm at a 10 : 1 image reduction, the effective focal length is 4.12 cm, the f -number is 1.4 at infinity and the spectral range is 436 nm \pm 7.5 nm. One of the design criteria for the lens was to maintain a large working distance between the lens and the image plane to provide for the lens air bearing which is described in Section 3.1.

The computed image distortion does not exceed 0.1 μ m at any point in the projected field. The calculated modulation transfer function (MTF) in the center, and at the edge of the field of view is shown in Fig. 5. Allowing for a slight decrease in these values due to manufacturing errors, the lens can produce 1-micron lines having a MTF of 0.4, which is adequate for exposing KHRP plates.

2.4 *Illuminating & Condenser System*

The purpose of the condenser system is to provide adequate illumination in the correct spectral range uniformly over the projected field. In the step-and-repeat camera, the exposure is made while the table is moving so as to reduce the time required to make a mask. Thus it is necessary to use a short exposure time to minimize the image blur.

In this camera the illumination is supplied by an EG&G, FX-76 flash lamp with a special glass envelope having a ripple-free front surface to minimize illumination non-uniformities. The lamp has a maximum rated power input of 15 W which is sufficient to expose six patterns per second on dyed KHRP emulsion. The flash duration is about 15 μ s

* Located in Fairport, New York.

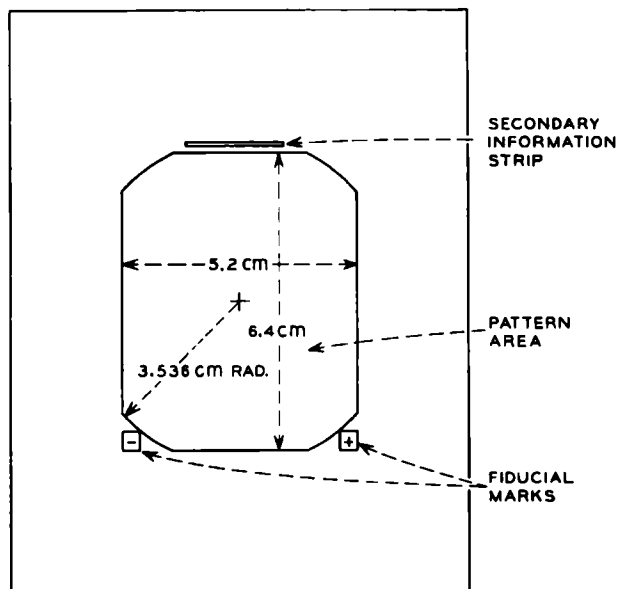

Fig. 3—Reticle format.

which allows a maximum table velocity of 0.5 cm per second with a line edge blur of less than $0.1 \mu\text{m}$. Another point of concern is that the jitter-time between the computer command and the onset of the flash should be small and constant; experiments of over a quarter of a million flashes show that the positioning error due to the jitter-time is less than $0.005 \mu\text{m}$. The maximum rated energy input to the flash lamp is 10 J which is four times that required to expose dyed KHRP emulsion.

A six-element condenser assembly with a large collection angle images the flash-lamp discharge onto the entrance pupil of the projection lens. The assembly contains a filter having a transmission bandwidth of 15 nm centered at 436 nm and having a uniform transmission to within 5 percent over its working area.

2.5 Mechanical Construction

The optical head, including its pneumatic control system and reticle-positioning electronics, is mounted on a Mechnite casting which bridges the interferometrically controlled stage. The head contains the projection optics, flash lamp, reticle positioning system, alpha-numeric

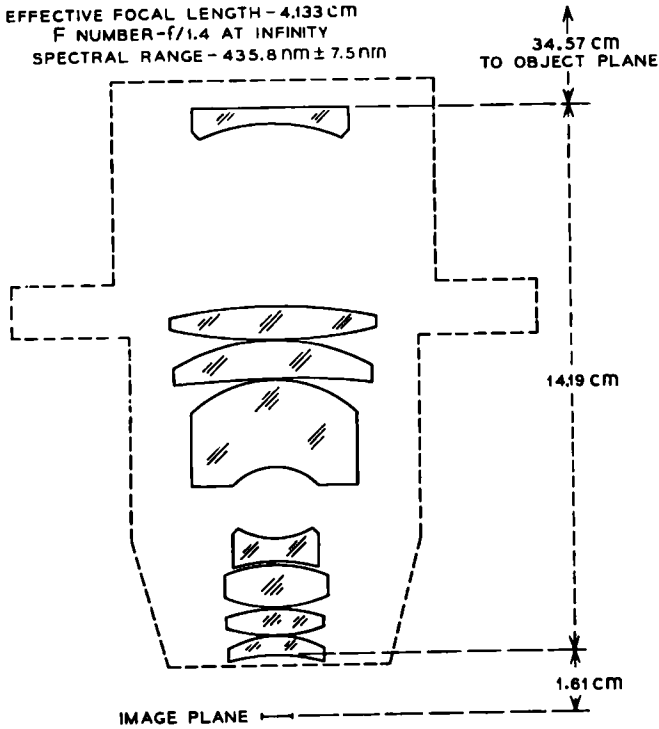

Fig. 4—Projection lens.

writing system and the machine language reading detectors (See Fig. 6).

The structure consists of three parallel plates separated by rods, the center or main plate being fastened to the top of the bridge. The upper, or reticle plate is supported on slender rods which permit lateral displacement of the plate for positioning the reticle. The plate displacement is controlled by stepping motors driving a low angle cam through a large gear reduction. This drive mechanism is mounted on the cylindrical housing that encloses the space from the main plate to above the reticle plate. A pneumatically operated cover, incorporating the flash lamp and condenser system, is hinged at the rear of this housing.

The lower, or lens, plate is suspended from the main plate by three rods and attached to the underside of the bridge by a diaphragm that prevents vibrations normal to and around the optical axis but permits

displacement along the axis. A housing, which provides the mounting for the projection lens, the lens air bearing and the retro-reflectors for the reference legs of the interferometer (See Section 3.4), is attached to the lower surface of the lens plate.

The plate and rod structure is designed to reduce the thickness tolerances on the plates. This has been done by grinding flat one reference surface on each plate. The rods then terminate on only these surfaces (See Fig. 6). Where required, the rods are inserted through holes in the plate and fastened to steel disks screwed to the reference surface. A similar construction is employed in mounting the projection lens, i.e., the lens housing is fastened to the reference surface of the lens plate and the lens flange is screwed to the interface surface of the lens housing.

The changes in the lens conjugates necessary to maintain the focus and magnification over a temperature range of $\pm 3^{\circ}\text{C}$ was calculated from the lens and lens holder design. These values were then used in selecting the materials for the rods and the lens housing so that the focus and magnification are compensated over the specified temperature range.

The head is aligned and focussed before it is installed in the bridge. The reference surfaces of the plates are set parallel to each other within

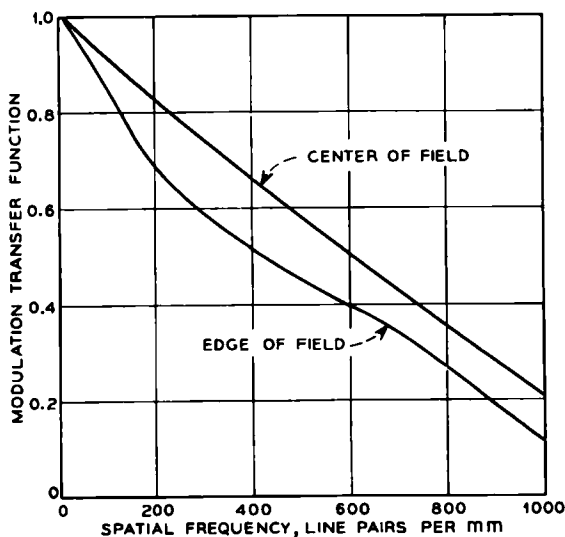

Fig. 5—Calculated modulation transfer function curves for the projection lens.

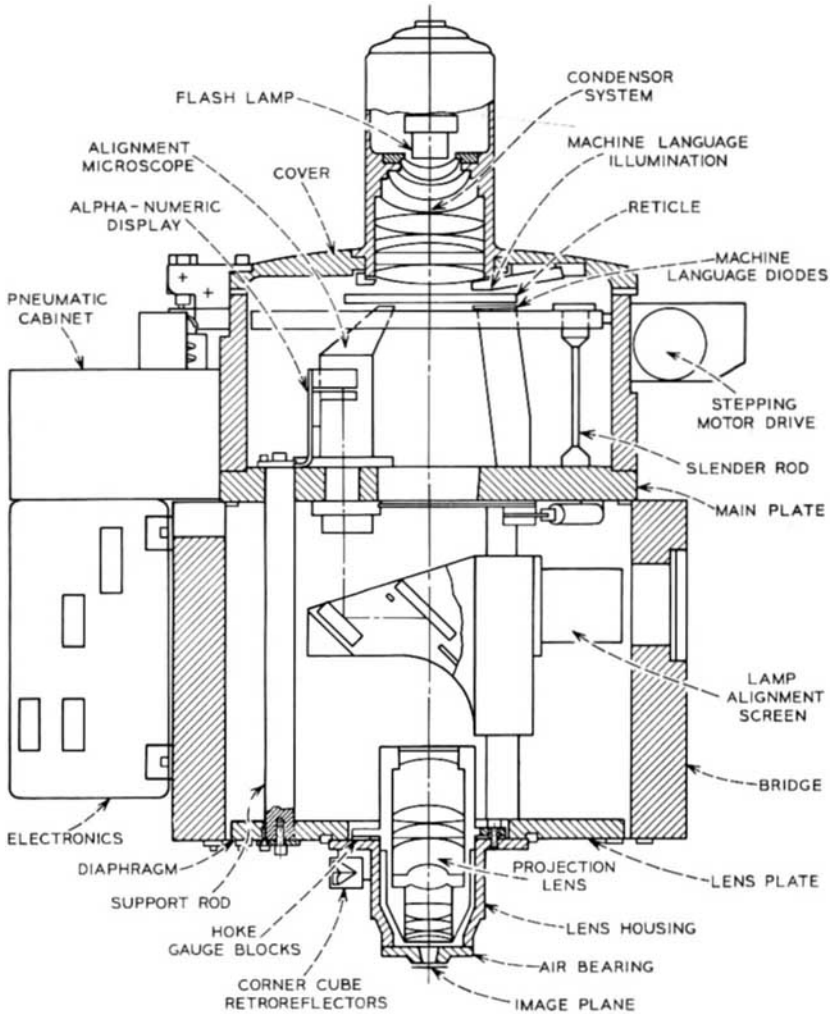

Fig. 6—Optical head assembly.

$25 \mu\text{rad}$ by adjusting the length of the rods. Centering of all parts, except the reticle plate, is controlled by the initial machining. The reticle plate is offset toward the stepping motor drives so that when the plate is centered the slender rods are flexed. The flexure of these rods causes the plate to maintain contact with the positioning drives.

The lens conjugates were measured on an optical bench and the rods

machined to these dimensions. This procedure can give only approximate positioning and adjustments are therefore provided in the design. The lens-flange-to-air-bearing distance is adjusted by interposing Hoke gauge blocks under the lens flange. This permits controlled adjustment in $2.5 \mu\text{m}$ step and angular adjustments of $50 \mu\text{rad}$. Final adjustments are made by varying the air space between the lens air bearing and the mask. The long conjugate is varied by changing three pads that support the reticle. A 0.5-mm range in $50\text{-}\mu\text{m}$ steps is provided. Since these adjustments are critical, they are not available for operator manipulation, i.e., the camera is a fixed focus and magnification instrument.

The air bearing holds the mask to within $0.25 \mu\text{m}$ of its theoretical position (See Section 3.1) which provides excellent control for image quality and introduces an image distortion of only 6 parts per million (ppm).

2.6 Reticle Alignment

The reticle is secured to its mount by six pneumatic plungers fed through throttling valves to give them a programmed sequence to insure that the reticle is correctly positioned against the locating pads. The locating pads are in the same location as those used in the reduction camera to help minimize the centering errors. The two fiducial marks on the reticle are imaged with a 5.5X magnification on to two EG&G, SGD-444 photodiodes. One fiducial mark is a cross pattern and is imaged on to a quadrant detector, for X - Y positioning, and the second mark is a straight bar pattern that is imaged on to a bi-cell detector, for θ orientation. The arms of the X - Y fiducial mark are $30 \mu\text{m}$ wide by $710 \mu\text{m}$ long, and θ fiducial mark is $40 \mu\text{m}$ wide by $1500 \mu\text{m}$ long. The X - Y mark is imaged on to the quadrant photo-diode as shown in Fig. 7.

The microscopes that image the fiducial marks on to the photodiodes incorporate the following features:

- (i) A bent optical path, provided by two dove prisms, prevents the structure of the microscope from infringing upon the main pattern projection area.
- (ii) Diode illumination, from an external light source via fiber optics, for visual alignment of the diodes.
- (iii) External rotation adjustment of diodes for initial alignment.
- (iv) A refractor block, which can be adjusted through the reticle plate, for aligning the pattern with the X - Y axes of the table to within an accuracy of $5 \mu\text{rad}$.

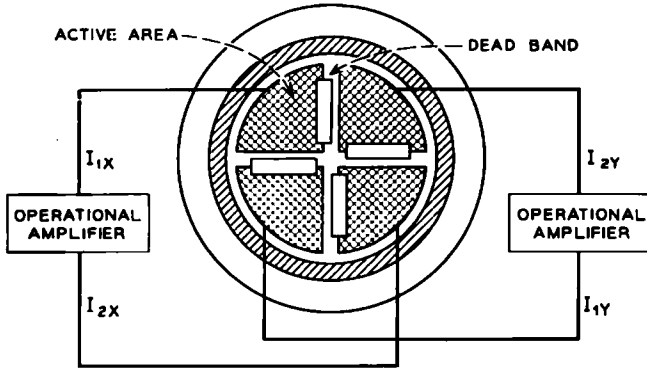

Fig. 7—Photo diode.

The output current from each quadrant in the photo-diodes is proportional to the amount of light focussed on to it, and the difference in output from conjugate quadrants is a measure of the reticle displacement. A schematic of the electronics is shown in Fig. 8. The diode outputs are amplified and converted to a voltage signal to give a reticle displacement sensitivity, near the balance point, of $1.6 \text{ V}/\mu\text{m}$. This signal is monitored by a voltage comparator having a dead-space window of $\pm 0.2 \text{ V}$ which is equivalent to a dead-band of $0.25 \mu\text{m}$. The signal-to-noise ratio at the balance position is about 20 to 1 thus ensuring adequate signal strength. The outputs from the comparators

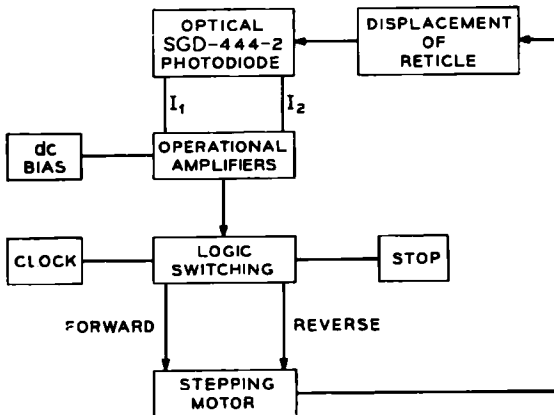

Fig. 8—Block diagram of reticle alignment electronics.

control switching logic which in turn drives three stepping motors. These move the reticle via the three low-angle cams to the balance position. One step of the motor displaces the reticle $0.02 \mu\text{m}$. Experimentally, the system positioning accuracy was measured to be $\pm 0.25 \mu\text{m}$. The total range of motion is $\pm 125 \mu\text{m}$; however, in order to avoid driving the cam through its transition region, the pattern on the reticle is required to be within $\pm 63 \mu\text{m}$ of its correct position. The total balancing time is about 15 s, which includes a 5-s pause at the end of the positioning period to ensure that the system is completely stable. The switching logic is then shut down, the stepping motors are put in the "hold" position, but the power to the amplifier and the photodiodes remains on at all times. Measurements to date indicate an overall drift of about $0.2 \mu\text{m}$ per day, and the drift during the period required to expose a complete mask is negligible. The complete electronic package includes a sensitivity calibration system that displaces the reticle one micrometer and measures the corresponding output voltage.

2.7 Machine Language Read-Out

The secondary information strip is monitored by the computer when the reticle has been positioned. The 42 bits are read as four separate groups for the convenience of transferring the information, each group having its own lamp and condenser system. The lamp is imaged on to each bit-area by means of a flys-eye lens array mounted just above the reticle, and under each bit-area is a photo-transistor for monitoring whether the bit area is clear or opaque.

2.8 Alpha-Numeric Display

A 5 by 7 lamp array is available for producing characters 2 mm high in the center of the field of view of the projection lens. A flys-eye lens array with 35 lenses each 2.5 mm square is placed just in front of the lamp array. The effect of the lens array is to increase the amount of light collected from each lamp, as opposed to using no lens array at all, and to image each lamp as a square on the mask. The required exposure time is 1 s which requires that the mask be stationary during the exposure.

2.9 Operation

The reticle is loaded in the camera by the operator and is clamped into position by activating an air switch. The camera cover is closed by an air-piston, activated by the operator, and the system is then transferred over to computer-control. The computer initiates the re-

reticle-positioning electronics which then proceeds to center the reticle. If for any reason the reticle has not been positioned after a given length of time, the computer turns off the servo-system and informs the operator. When the computer has been informed that the reticle is correctly positioned, it will then read the secondary information strip to ensure that the correct plate is in the camera. The optical head is now ready for operation.

III. STAGE ASSEMBLY

3.1 *Focus Control*

For a lens capable of 1.0- μm line resolution and precise control of magnification, the depth of focus is less than 1.0 μm . Since photographic plates having a submicrometer flatness are unavailable, an automatic focusing system is required to assure well-focused images over the entire step-and-repeat array. The flattest commercially available photographic plates for use in this camera, are Mirco Flat KHRP.* These have an over-all flatness of 6.5 and 16 μm respectively for the 4" \times 5" and 8" \times 10" plates. If the surface at the plate's perimeter is positioned at the image plane, the remaining portions of the plate will be above or below the image plane by as much as the flatness specification and the resulting images will be unacceptable. In addition to the plate's lack of flatness, its emulsion is 6 μm thick, thus only a thin layer of the emulsion can be in focus, the rest being out of focus. This difficulty was overcome by R. E. Kerwin¹ who dyed the emulsion with a material which absorbs strongly at 436 nm. The dyed plate is then only exposed at its top surface and it is only this surface which must be maintained in the lens image plane.

To maintain the plate in focus, it is mounted in a softly suspended fixture attached to the stage. The plate's emulsion surface is allowed to glide under a stiff air bearing which is attached to the lens housing. Since the lens air bearing is in effect a very stiff spring and the plate support system is relatively soft, the distance between the photographic plate and the lens bearing will be nearly constant for large deflections of the plate holding system. From Fig. 9 it is possible to predict the performance of this focus control scheme. If K_p and K_b are the stiffnesses of the plate support and the lens bearing and ΔY is the deflection of the plate supporting fixture due to photo plate distortion, the resulting change in plate-to-lens bearing force is Δf . This results in a plate-

* Manufactured by Eastman Kodak, Inc., Rochester, New York.

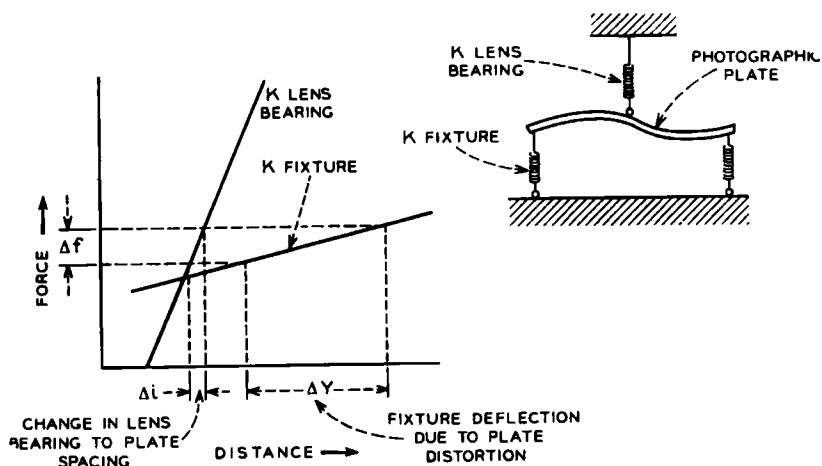

Fig. 9—Theoretical prediction of focus control system performance.

to-lens spacing change of Δi . For a given plate distortion the error in the emulsion surface location is proportional to K_f/K_b , which in practice is about 40. This results in focus errors of 0.15 and 0.3 μm for 4" \times 5" and 8" \times 10" plates respectively.

The mechanical realization of the focus control may be seen in Fig. 10. The photographic plate is pneumatically clamped in a fixture. The emulsion side, which is up, rests against 14 co-planar pins which locate the perimeter of the top surface parallel to the lens' image plane. The plate clamping fixture is in turn attached to the movable step-and-repeat camera stage by four pairs of stressed parallel springs. This suspension system is stiff to all rotations and translations excepting motion in the vertical direction. In order to minimize the vertical stiffness (k_f) the springs must be horizontal; however, in this position their load-bearing capacity is zero. Therefore, to support the weight of the plate and its clamping fixture an annular groove covered with a flexible diaphragm is provided under the plate-supporting fixture. This is inflated until the diaphragm, acting against the main stage, makes the springs horizontal and brings the edges of the clamped plate to the elevation of the image plane. By inflating the chamber each time a new plate is loaded, the correct starting elevation is achieved regardless of differences in plate weight or barometric pressure. The pneumatic counterbalance would add no stiffness to the plate support system if it were operated at constant pressure. However, it is more

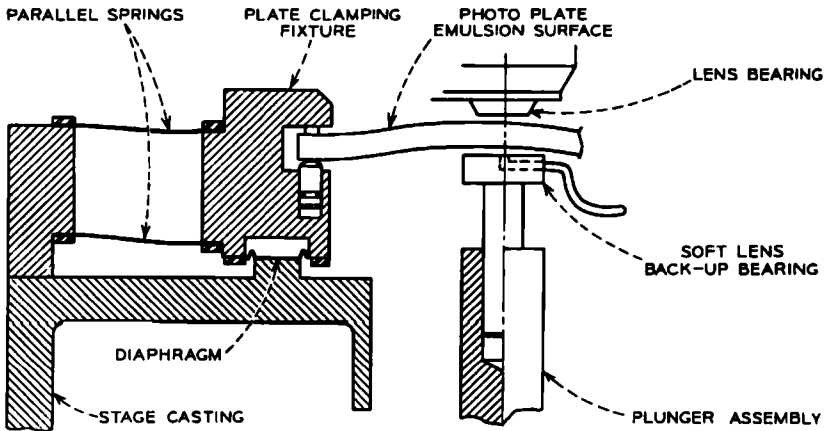

Fig. 10—Focus control system.

practical to inflate the system to the proper height and close the valve than to establish and maintain the correct pressure; therefore, it is operated at a constant volume. The combined stiffness of the parallel springs and pneumatic counter balance system is between 5.0×10^4 and 8.5×10^4 N/m.

The lens bearing is 2.54 cm in diameter and has a central 0.94-cm hole through which the image is projected. The placement of this bearing between the lens and the surface is only possible because of the lens' large working distance. In operation the lens bearing-to-plate spacing is 12.5 μm , its stiffness is 4.4×10^6 N/m, and the normal force which it exerts against the plate is 44 N. If this load is transmitted to the fixture and diaphragm through the photographic plate, it will result in a large deflection of the plate and increase the difficulty of maintaining good focus. Therefore, an equal but opposing force is applied to the lower surface of the plate by a soft air bearing placed directly below the lens bearing. This bearing is mounted on a low friction pneumatic plunger which is raised into place after the plate is loaded. This bearing provides nearly constant upward force on the plate regardless of plate bow or taper and does not contribute to the system stiffness. A further discussion of the air-bearing design is given in Section 3.3.

The focus control system was evaluated by using a laser interferometer in place of the projection lens to measure the relative motion between a mirrored plate clamped in the fixture and the lens housing. Using typical plates the focus control is able to maintain the

elevation of the plate's surface on the optical center line within $\pm 25 \mu\text{m}$ of the image plane.

3.2 Stage Design

All major parts of the camera are supported on a one-meter-square block of granite. The top surface of the granite is flat to $2.5 \mu\text{m}$ and three 15-cm-square areas under the stage support bearings are parallel to within $5 \mu\text{rad}$. The block is supported on three special Barry Control Corporation* Serva-Level® mounts which provide vibration isolation in the vertical and horizontal directions. The vertical and horizontal natural frequencies are 0.82 Hz and 0.87 Hz respectively. A 1200-kg lead ballast is attached to the underside of the granite to lower the camera's center of gravity and assure the stability of the Serva-Level® system. The extra ballast also increases the working pressure in the air mounts which minimizes the effects of sudden changes in the ambient pressure due to opening and closing doors in the air conditioned facility.

The stage is supported on three two-inch-diameter air bearings. Each bearing is attached to the stage through a spherical bearing assembly and a spacer made up of Hoke gauge blocks (See Fig. 11). The spherical bearing assembly allows some initial angular adjustment of the bearing during assembly and alignment; however, once the weight of the stage is resting on the bearing the static friction in the spherical bearing prevents further movement. The gauge block stack between the bearing assembly and the stage allows the elevation and tilt of the stage to be adjusted more accurately than is possible by machining. Since the stage rests directly on the granite surface rather than on an intermediate stage as is customary in machine-tool construction, its attitude depends only on the granite surface and is constant within $2.5 \mu\text{rad}$.

The stage is guided by an intermediate structure which is called the cross. The cross is constrained to move only in the X (right-left) direction by two pairs of 2.5 cm-diameter air bearings and two colinear quartz guide blocks which are secured to the granite base. The sides of the guide blocks are straight and parallel to $0.25 \mu\text{m}$ and the blocks are optically aligned on the granite surface to achieve a cross yaw of less than $1.25 \mu\text{rad}$ over 10 cm. The cross is supported on four 2.5-cm-diameter air bearings, two resting directly on the granite surface and two on the top surface of the quartz guides. All of the cross support and

* Located in Watertown, Massachusetts.

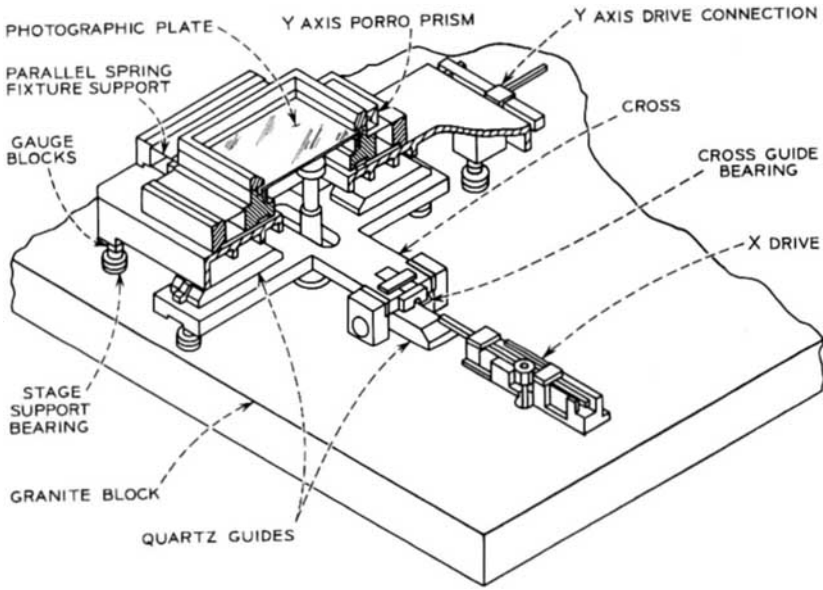

Fig. 11—Cross section of stage showing cross and drives.

guide bearings are also assembled using spherical bearings and gauge blocks. The stage is also guided by four air bearings and a pair of quartz guide blocks mounted on the top surface of the cross parallel to the camera's Y axis. The straightness of travel along this axis is similar to the X axis giving a total stage yaw of less than $2.5 \mu\text{rad}$ over the entire $10 \times 10\text{-cm}$ travel of the stage. Therefore, this is the maximum rotational error between any two images on the final mask due to the guiding system.

The parallel springs of the plate holding fixture are attached at the outer edges of the stage. This fixture and its diaphragm support rest on the top surface of the stages. The elevator bearing for the focus control system is attached to the granite surface on the optical axis and passes up through a slot in the cross.

The X -axis drive is attached to the cross through a slender flexible column which allows both vertical and horizontal misalignment between the cross and drive. Under worst-case conditions, the maximum cross rotation due to the force required to deflect this member is $0.1 \mu\text{rad}$. The Y -axis drive is coupled directly to the stage through two air bearings and a guide bar attached to the stage.

All of the camera's major components are cast from Meehanite GC-40 because of its good stability and good damping qualities. The castings were X-rayed to assure their soundness and were heat treated prior to initial machining, prior to the final grinding operation, and again after all machining operations. This heat treatment provides phase stability (ferrite and graphite) and assures low creep rates under the low stress conditions of its use. All nonmating surfaces were then painted with an air dry vinyl paint.

3.3 Air Bearings

The stringent requirements of position and focus control necessitated that the camera be supported and guided by stiff low-friction bearings. Investigation of various bearing types revealed that gas hydrostatic thrust bearings possessed the necessary characteristics to meet these requirements.² They operate in a nearly frictionless manner (frictional resistance is about 1/4000 of that of a light oil bearing). They are very simple in construction permitting relative ease in meeting mechanical tolerance requirements. Their load-stiffness characteristics are such that camera requirements can be met with low gas-supply pressures ($<3.4 \times 10^5$ N/m²) and total gas consumption ($<2.3 \times 10^{-3}$ standard m³/s).

The performance and space requirements for the various air bearings employed on the camera are indicated in Table II. The plate bearing is a central-jet type and the remaining bearings are ring-jet varieties (See Fig. 12).

The design and development of the gas bearings involved both analytical and experimental programs. The analytical program consisted of computer predictions of steady² and transient³ behavior of the aforementioned bearing types. The experimental program was used to verify analytical predictions as well as prove-in the focus-control system. Typical results of these programs are shown in Table III and Fig. 13.

TABLE II—AIR BEARING REQUIREMENTS

Bearing	Load	Stiffness	Space
Main Stage	160-220 N	$1.2-1.8 \times 10^7$ N/m	5.08 cm OD
Cross Support	36-54 N	$0.35-0.53 \times 10^7$ N/m	2.54 cm OD
Cross Guides	22-45 N	$0.18-0.35 \times 10^7$ N/m	2.54 cm OD
Lens	36-54 N	$0.35-0.53 \times 10^7$ N/m	2.54 cm OD
Plate	Force equal to Lens B	Zero or Finite but small	3.81 cm OD

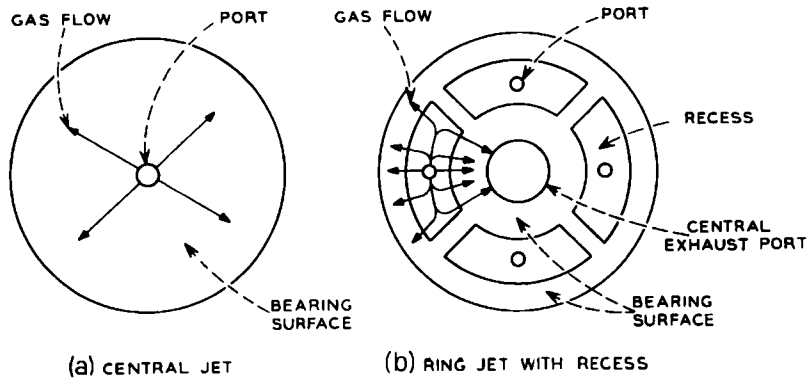

Fig. 12—Air bearing configurations.

3.4 Interferometer Design

The correct placement of every image on the photographic mask is a primary requirement of a step-and-repeat camera. Therefore, special attention was given to the design of the camera's interferometers. Both the X and Y interferometers are identical and they share the output of a frequency stabilized HeNe laser. Their outputs indicate both the direction of stage motion and the distance traveled. Each output pulse represents $0.04\text{-}\mu\text{m}$ stage travel or $1/16$ wave length (λ). The interferometers are arranged in a double pass configuration so that each fringe represents a $\lambda/4$ displacement of the stage (See Fig. 14). Two photocells monitor the output light beams whose phases differ by 90° . This phase difference is achieved by the use of circularly polarized light and polarizers before each photocell, and it is used to indicate the stage's direction of travel and to further divide the output fringe

TABLE III—ACTUAL AND THEORETICAL AIR BEARING CHARACTERISTICS

Bearing	Load Range N	Gas Supply Pressure N/m ²	Average Stiffness N/m	
			Theoretical	Experimental
Lens & Cross Support	38-53	1.4×10^6	4.3×10^6	2.6×10^6
		2.8×10^6	5.5×10^6	4.4×10^6
Main Stage Support	154-220	2.1×10^6	14×10^6	11×10^6
		2.8×10^6	18×10^6	19×10^6
Guide	25-43	2.1×10^6	5.6×10^6	2.9×10^6
		2.8×10^6	5.8×10^6	4.2×10^6

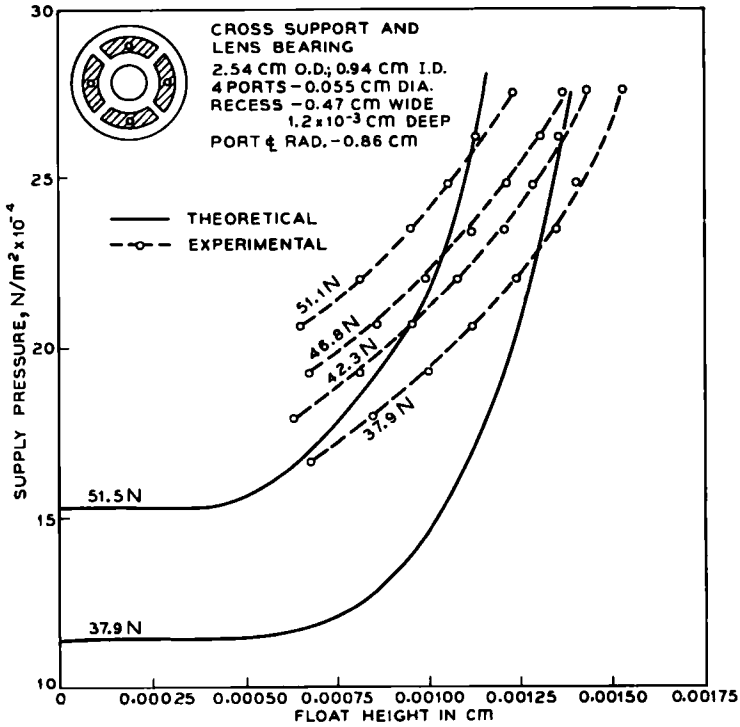

Fig. 13—Theoretical and experimental air-bearing characteristics.

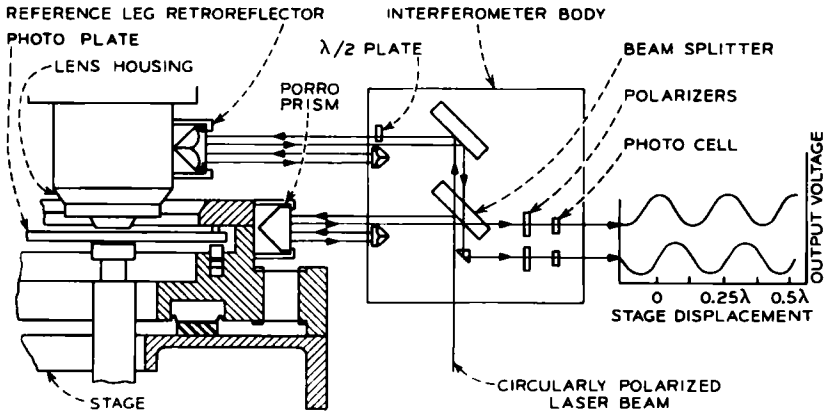

Fig. 14—Arrangement of stage position interferometer.

interval by four through the use of the two signals' zero crossings. Judicious placement of the interferometers is required to assure the maximum accuracy of the camera. For instance the *X* and *Y* measuring legs intersect the camera's optical axis thus making the measured location of the image independent of small stage rotations about the vertical axis. For machines in which the measuring legs do not intersect the optical axis, legitimate translations and errors due to rotation are indistinguishable. (This is always the case with some heads of a multiple-head camera.) Similarly, the measuring beams are at the same elevation as the photographic plate making the image position independent of small amounts of stage pitch and roll.

The measuring legs are terminated at the stage by 12-cm-long porro prisms. The photographic plate is rigidly attached to these prisms through the plate-clamping fixture, thus assuring that motions of the porro prisms are identical to those of the photo plate. Since the stage-drive system continually moves the stage to maintain a particular fringe count, its location along the two axes is dependent only on the straightness of these prisms and not on the straightness of the stage guides. Similarly the orthogonality of the two axes is only dependent on the relative mounting of these prisms. On the camera these prisms are set at right angles to within $1.25 \mu\text{rad}$.

The reference leg retro-reflector is attached to the optical head as close to the image plane as is practical. In this way the interferometer output represents the relative locations of the stage and the optical head rather than the location of the stage with reference to a leg fixed in the interferometer body as is the usual practice. This allows compensation for deflections of the optical head which would otherwise go unnoticed.

The optical parts were fabricated from fused silica because of its excellent stability. They use total internal reflection and are not anti-reflection coated in order to eliminate the mechanical distortions which frequently accompany the deposition of these coatings. They have a wave-front accuracy of one-tenth wave over their 12-cm length and they are mounted in a nearly stress-free state so their accuracy will not be reduced by mechanical strain.

The laser wave length changes with variations in atmospheric conditions. Since the room temperature is maintained constant to $\pm 0.13^\circ \text{C}$, corrections for temperature are not necessary. However, barometric corrections are made prior to each exposure because pressure variation of $3.44 \times 10^3 \text{ N/m}^2$ results in $1.0\text{-}\mu\text{m}$ errors. When wave length corrections are calculated, the actual difference in the measuring and ref-

erence leg lengths must be known. Therefore, the granite table has been fitted with sensors which allow the establishment of one absolute stage position from which all corrections for varying ambient conditions are made.

3.5 Stage Drive

The stage and cross are driven by identical low-backlash drive systems. Motion in the *X* and *Y* directions is imparted to the cross and stage through 1.3-cm-square bars which are guided on all sides by air bearings, and driven longitudinally by a capstan which is an extension of the motor shaft (See Fig. 15). Sufficient driving force is achieved by pinching the drive bar between the driven capstan and a spring-loaded idler. The capstan and idler shafts are mounted so that no net transverse force is transmitted to the drive bar and they are prevented from moving in the direction of the drive bar by flexures attached to the body of the drive unit. The motors are mounted below the granite table and their shafts pass vertically through holes in the granite in an

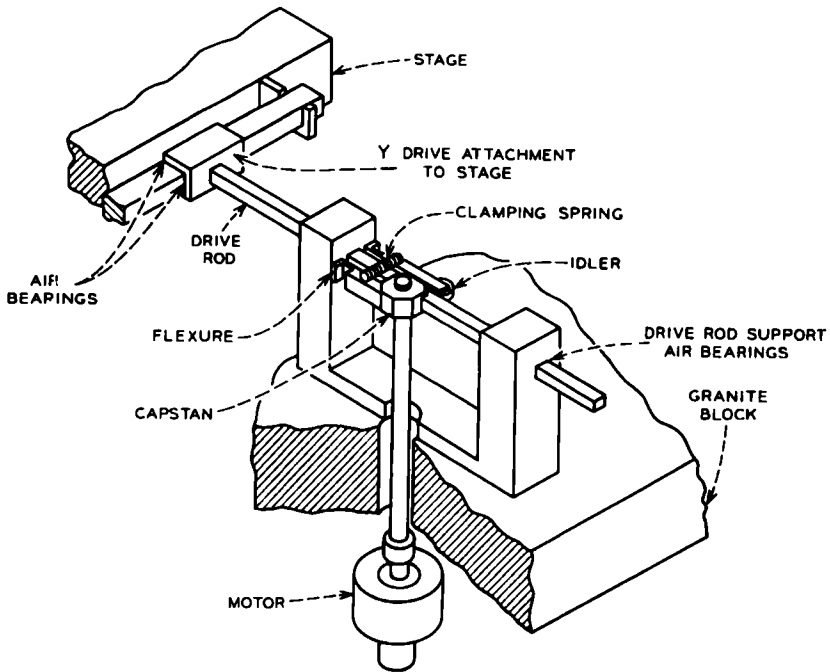

Fig. 15—Y axis drive.

attempt to minimize any heat transfer from the motors to the camera structure. The lack of gearing and the use of flexures minimizes the drive train backlash and enhances the system stiffness.

The drives can move the stage at any uniform velocity up to 0.5 cm/s and they are capable of stopping the stage from this velocity in less than 2^{11} interferometer counts ($80 \mu\text{m}$). They can also maintain the stage to within plus or minus two interferometer counts ($0.08 \mu\text{m}$) of its desired position. This is accomplished through the servo system which is shown in block diagram form in Fig. 16.

IV. CONTROL SYSTEM

4.1 Servo System

Since the X- and Y-axis servo systems are identical only one will be discussed. They operate in three modes: constant speed slewing, decelerating from a constant speed and holding at a fixed location. The stage velocity is determined by the value in the twelve-bit speed register which is converted to an analog signal in the digital-to-analog (D/A) converter. Thus when the number in the speed register remains constant, the D/A output is fixed and the stage runs at a constant speed. The stage velocity is stabilized through a digital tachometer feedback loop which uses the rate of interferometer pulses to determine the stage velocity. The drive system stability was further enhanced by the addition of a small viscous damper on the motor shaft.

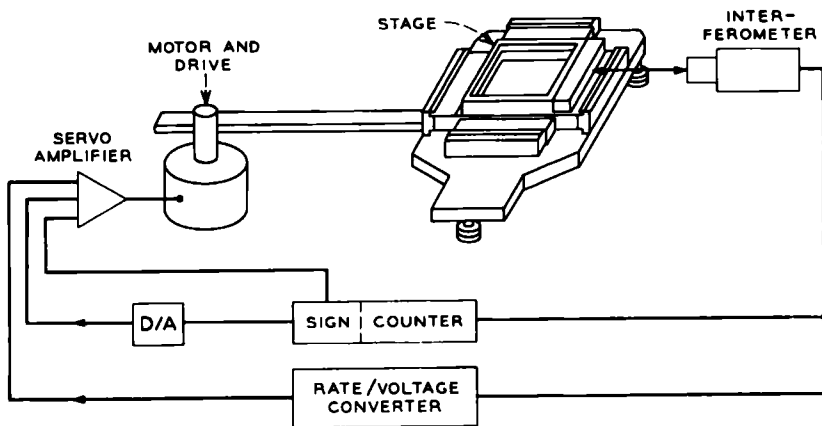

Fig. 16—Block diagram of stage-positioning servo system.

When the stage must stop at a given location, the value in the speed register is made equal to the distance from the stopping location in interferometer counts ($0.04 \mu\text{m}$ per count) and the D/A output voltage decreases toward zero as the stopping location is approached. When the stage is at the desired location, it is imperative that the value in the counters become zero and remain or recross zero in a small limit cycle so that each image on the step-and-repeat mask will be in the correct location. Ideally when the position error is zero, the stage should stop and if it moves slightly, say one count, the motor should again drive it to zero. Unfortunately small amounts of drift in the D/A converter or the servo amplifier will cause the stage to stop and remain at some point with other than zero in the counter and speed register. Even without this electronic drift, the system's static friction, although small, will require unreasonably large gains to assure that errors of one count in the speed register ($0.04\text{-}\mu\text{m}$ stage position error) will be corrected.

Both problems have been overcome by demanding that the stage execute a small limit cycle which includes the zero location. This is accomplished by adding to the D/A output a two-valued function which is positive when the speed register is positive and negative otherwise (See Fig. 17). The magnitude of this step voltage is just sufficient to cause the motor to drive the stage toward zero in spite of electronic drift and mechanical stiction. This assures a continual re-crossing of the zero-minus-one transition point. In addition it reduces the positioning error by removing the dead band of $0.04 \mu\text{m}$ which occurs if the stage location corrections are made only when the value in the speed register becomes plus or minus one.

4.2 *Digital Computer and Interface*

The control of the camera is coordinated through a Digital Equipment Corporation PDP-8/L computer. This has a 12-bit word length, a cycle time of $1.6 \mu\text{s}$ and 4096 words of core memory. Its function is to provide communication between the operator, the camera and the MSIS and to make the necessary conversions and calculations for the camera's operation. The connection to the MSIS PDP-9 computer is through an interface and a high-speed data link. The interface provides buffering to allow data transfer between the computers to occur asynchronously. The information transferred across this link includes step-and-repeat array data from the information system, operating status, and requests for information from the camera. The computer

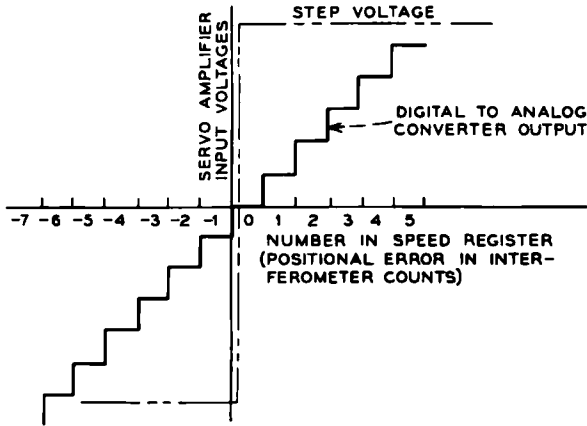

Fig. 17—Servo amplifier input voltages versus stage-positional error.

and interface racks are located outside the step-and-repeat camera room to minimize any heat transfer to the camera structure.

The information transferred between the camera and the PDP-8/L is stored, acted on, and relayed by three other interface sections, each of which consists of about 180 DTL integrated circuits on a board with wire wrapped interconnections (See Fig. 18). The three sections are the identical X- and Y-axis control interfaces and the accessory interface. The latter interface monitors camera functions and provides special tests, which are not related to the stage positioning system, such as reticle identification, interlock testing, and atmospheric pressure monitoring.

Operator/computer communication is also affected through the accessory interface which controls both an illuminated message board and an auditory alarm as well as storing input from the operator keyboard. An additional interface allows the computer to output supplemental instructions of a variable nature on a CRT display.

The X- and Y-axis interfaces interconnect their respective interferometers and drives. These interfaces, once loaded from the PDP-8/L, are capable of positioning the camera stage at any location within the limits of its travel and exposing an image on the plate at that point without further intervention from the computer, thus leaving the computer free for other work.

Each axis interface has two storage registers which may be loaded from the computer. A 24-bit register contains the address of the stage's

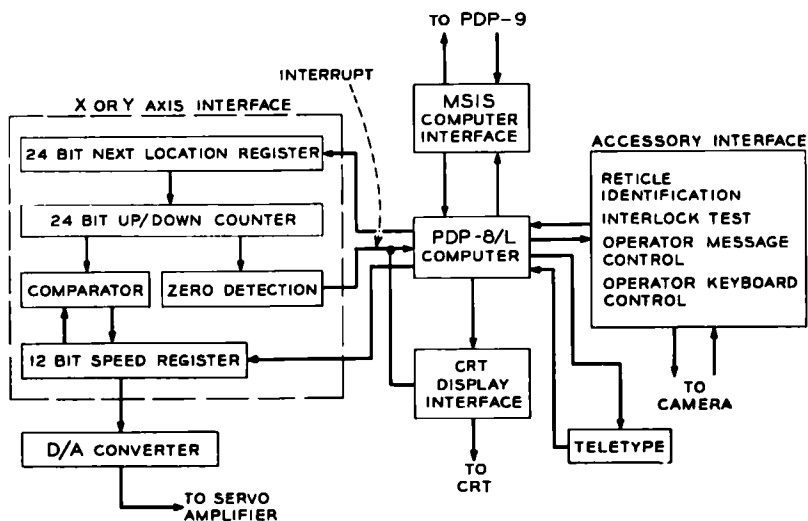

Fig. 18—Block diagram of computer/camera interface.

“next location” relative to the current stage destination, and a 12-bit register (the previously mentioned speed register) which contains the binary equivalent of the speed at which the stage is to move. The heart of the interface is a 24-bit binary up/down counter for accumulating interferometer output pulses. It consists of four six-bit parallel-carry counters connected in series to allow counting in either direction at rates of 4 MHz. This counter is initially loaded with a number from the “next location” register and the stage is moved until the counter becomes zero. At this time the optical head flash lamp may be triggered and the counter may be automatically reloaded from the “next location” register.

The speed register and the counter are connected to a comparator which, upon a command to stop at the next location, will compare their contents. When they become identical it will continually transfer the value of the counter into the speed register keeping these two equal. This makes the value in the speed register proportional to the distance from the stopping location thus providing automatic stage deceleration. The interface also initiates a computer program-interrupt when its counter has become zero. This immediately alerts the computer to the fact that its previous requests have been carried out and that the status of the interface may be updated.

The size and complexity of the axis interfaces justify the inclusion of several special functions. These allow the computer, using a special program, to perform maintenance tests on these interfaces to identify malfunctions and enumerate possible corrective actions.

V. COMPUTER PROGRAM

The program stored in the step-and-repeat camera control computer, the PDP 8/L, couples the camera's systems into an automatic production tool. Logic sequences of this program could have been provided by hardware logic components; however, implementation in this manner would not allow the flexibility of a computer program and would require many more electronic components. The balance between program logic and hardware logic has been established by providing hardware functions that greatly reduce either program complexity or computer time and by utilizing program logic where decision making or complex hardware logic would be required. The division of logic functions between hardware and program has been greatly influenced by experience with previous Bell Telephone Laboratories computer controlled photolithographic equipment.

Features utilized in the program to accomplish the control objectives are:

- (i) Live interaction with the operator at all times using non-interrupt programming;
- (ii) Input data conditionally accepted at any of three input terminals with two of the terminals serving a dual use for operator control;
- (iii) Message board and CRT display used to communicate with the operator;
- (iv) Multiple use of the axis-control routine and all other routines when possible;
- (v) Overwriting loader areas to provide maximum utilization of computer core; and
- (vi) Self starting of the program on loading with a checking routine to verify correct loading.

5.1 *Functions Performed by the Program*

The control program's objective is to provide automatic control of pattern placement on a photographic plate. In this operation the only operator tasks are: initializing the computer program, installation and removal of the photographic plate, and installation of reticles as re-

quired. However, in cases of mask shop operational decisions and equipment malfunctions, operator intervention is also needed. These requirements have resulted in a set of necessary control program functions:

- (i) Initialize and terminate a table maneuver.
- (ii) Transfer data as needed to the interface.
- (iii) Reproduce a series of text characters at specified locations on the photographic plate using the 5×7 light array.
- (iv) Automatically zero the table (initialize the interferometer counters).
- (v) Read a decimal input format and convert it to binary values suitable for interface use.
- (vi) Summon the operator when human intervention is needed.
- (vii) Communicate with the operator through a message board and a CRT display.
- (viii) Check installed reticle for correct identification number and control its alignment procedure.
- (ix) Receive input from either the operator, a paper tape in the teletype or the MSIS computer as specified by the operator.
- (x) Provide a maintenance function which transfers control of the table to the maintenance keyboard.

These ten functions are either self descriptive or have been described in prior sections.

The format used to transfer data from outside sources to the step-and-repeat control computer include nine code characters:

- Y*—Indicates *Y*-axis coordinate value;
- X*—Indicates *X*-axis coordinate value;
- D*—Spacing between images;
- N*—Number of images on (*D*) spacing;
- R*—Repeat the last line of data;
- A*—Repeat the data preceding the last line;
- E*—End the run;
- *—Following characters represent a reticle number; and
- "—Enclosed characters are to be written as text on the mask.

The first four code characters require that a minimum of one digit follow them to specify their magnitude with a maximum of seven digits. For the convenience of paper-tape input, a decimal point may be used with the digits to the left of the decimal point indicating the distance in millimeters. If one or two digits are specified and no decimal

point is used, the decimal point is assumed to be after the last digit. For more than two digits, the decimal point is assumed to be after the third digit.

Whether rows or columns will be run is determined by the sequence of the first two code characters following a reticle number or a text request, or upon starting a new mask array. If the sequence is $Y-X$ the program assumes the data following is to be placed in rows with all subsequent Y s being the Y coordinates of their respective rows. Alternately, the sequence $X-Y$ signifies column data with the columns located at the specified X coordinates. Image locations along a row (column) are specified by subsequent X s or by a D followed by an N , each followed by its appropriate digit value. Numbers following N s are evaluated as integers and not by the aforementioned decimal format. The only restriction on this format is that all values along a row or column must be in increasing magnitude.

5.2 Program Philosophy

A block flow diagram of the control program is shown in Fig. 19. In this figure bold lines indicate the main path of control through the program, light lines indicate paths that are taken when the block's function has been requested and broken lines are paths taken in going to the control routines when a waiting point has been reached. Most of these waiting points are labeled as "gates". These gates are points in the program that a control function dare not pass until some task has been completed. For example, the run and the main gates prevent simultaneous operation in either the run area, which is controlling the table motion, or the loading area, which is bringing in data and deciphering coded characters. The keyboard monitor routine maintains contact with the operator, allowing intervention in the camera's operation.

The program for running the camera has been developed using a foreground-background philosophy. Since the primary purpose of the program is to control the camera, the foreground program is the set of routines which directly control the table motions. The main routine of the foreground program is a general running routine which will control an axis through its most general maneuver, that of running along a row or column and exposing images at specified locations. To accomplish this, the routine requires the table of data for image placement to be available in the computer core. Because of the urgency in transferring information to the interface hardware when a task is completed, the foreground program is interrupt addressed.

Maneuvers of the stage other than the most general are accomplished by defeating inappropriate functions in the general running routine to

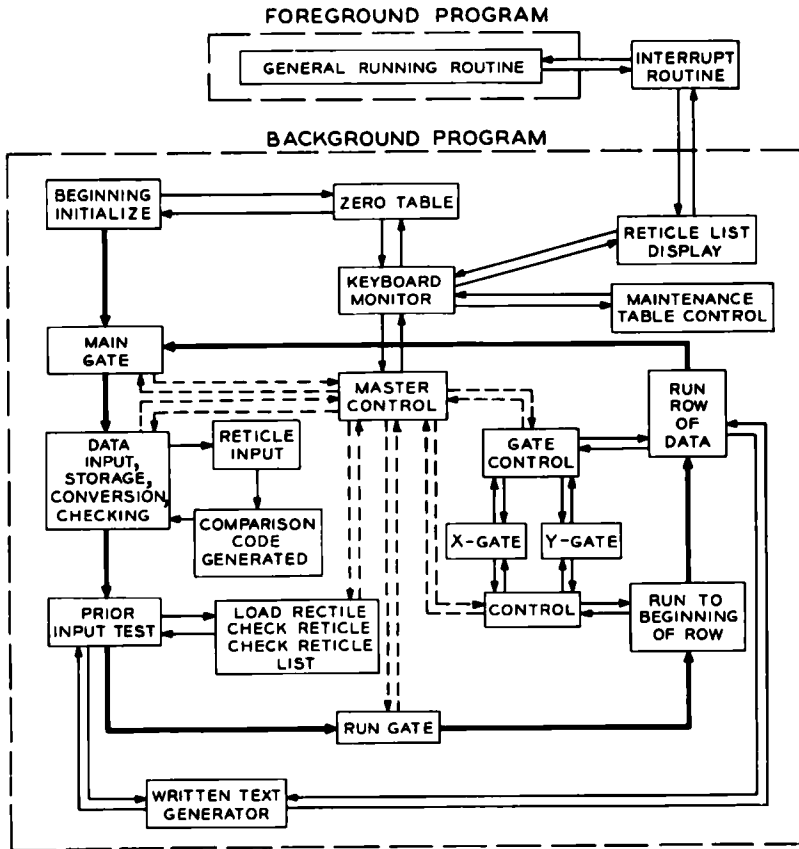

Fig. 19—Program block flow diagram.

make it perform as required. These changes are made prior to the desired maneuver and the general running status is restored after the maneuver is completed.

The background program provides input points from the communication equipment and communicates with the operator. This program operates on a noninterrupt philosophy. Noninterrupt programming is used because D.E.C. teletypewriter philosophy will cause the computer to overflow its limited storage capacity when operating with paper-tape input. The teletypewriter's hardware interrupt has been disabled to allow this noninterrupt philosophy.

To eliminate waiting time for slow input terminals like the teletypewriter, the machine waiting points are programmed to return control

of the computer to a master-control routine. The master-control routine then cycles through the other waiting points searching for work to be done. This technique allows the general running routine to be initialized and, while waiting for the addressed axis to complete its maneuver, the second axis can be initialized and data received from the input terminals.

Control information from the operator is entered through the operator keyboard or the teletypewriter. However, if the teletypewriter is being used to input data, operator control through the teletypewriter is not allowed.

Output to the CRT display is controlled through the computer interrupt facility after being initialized by the background program. This implementation was made because interrupt techniques minimize the asynchronous nature of this transmission.

5.3 Implementation of the Program

To implement the required functions with the control program, all locations in the 4096-word core of the PDP-8/L have been assigned an operational use. In doing this all program loaders are written over the background routine. The program logic occupies all locations from 0 through 5777₈. Locations 6000₈ through 6777₈ are used to store incoming data, the first half from 6000₈ through 6377₈ being table 1 and the second half, 6400₈ through 6777₈ being table 2. Each table contains the information for one row or column of images. The technique of using two data storage tables allows reading data into one table while the second table is being used to run a row or column of images. It also allows a mask using only two types of spacings to be produced by only transferring the Y- (or X-) coordinate values for all rows (or columns) following the initial table information transfer.

Locations 7000₈ through 7777₈ are used to store the list of reticles used to make a mask. This area is also divided into two equal table areas. One area will store the list of reticles for the current mask. When the data is transferred from the MSIS computer, the table is loaded immediately following the initiation of a job. However, when the job is being entered through the teletypewriter, this table area will store each reticle number at the time the operator is requested to load the reticle into the camera.

The second table area contains the list of reticles used to generate the preceding mask. Either of these two lists may be displayed on the CRT display at the operator's request.

Initial loading of the program has been reduced to a "push button" operation through a hardware deposited elementary loader. When this loading is complete and the computer is started, any tape which is in the high-speed, perforated tape reader will be read. In the case of the program tape for the step-and-repeat camera computer, the D.E.C. binary loader has been incorporated at the beginning with a sufficient number of statements added to cause the computer to switch from the elementary loader to the binary loader. The binary loader then loads the program's binary tape without the computer coming to a stop. At the end of the program, binary tape statements have been included which overwrite the binary loader and switch control of the computer to a test area to check for correct loading of the program. If the program has been properly loaded, the computer starts the camera control program. If the computer must be stopped, a restart location has been provided for the operator.

VI. CONCLUSION

We have discussed the design of a step-and-repeat camera capable of meeting the most exacting integrated circuit mask requirements. The requirements for precision image placement, 1- μm line-width resolution, and minimum operator intervention have influenced every aspect of the camera's design. A system capable of maintaining the photographic surface in focus to within $\pm 0.25 \mu\text{m}$ was developed in order to assure maximum image resolution and correct image magnification. The stage guide, drive and measuring systems utilize air bearings and multiple-pass interferometers to achieve precise image placement. The computer program provides, in addition to camera control, operator checking and communication to simplify the operator's job and to minimize errors.

VII. ACKNOWLEDGMENTS

The authors wish to pay tribute to P. Fritz, E. S. Jarzena, R. C. Joseph, D. C. Noack, and E. A. Toepel whose work in assembly, alignment, and testing have made the realization of this camera possible.

REFERENCES

1. Kerwin, R. E., "Thin Photosensitive Materials," B.S.T.J., this issue, pp. 2179-2192.
2. Gross, W. A., *Gas Film Lubrication*, New York: John Wiley & Sons, Inc., 1962, pp. 255-306.
3. Roubush, W., "An Analysis of the Effect of Several Parameters on the Stability of an Air-Lubricated Hydrostatic Thrust Bearing," National Advisory Committee for Aeronautics Technical Note (NACATN) 4095, 1957.

