

Faster Superconducting Quantum Computers

The coupling strength can also be increased to several tens of megahertz by increasing the magnetic flux, which realizes fast two-qubit gate operations. Simulations have shown gate operations with an accuracy of 99.99% are possible, with gate times as short as 24 ns. The coupler is thus expected to contribute to higher-performance quantum computers. [30]

The secret to building superconducting quantum computers with massive processing power may be an ordinary telecommunications technology—optical fiber. [29]

Superconducting quantum microwave circuits can function as qubits, the building blocks of a future quantum computer. [28]

Physicists have shown that superconducting circuits—circuits that have zero electrical resistance—can function as piston-like mechanical quantum engines. The new perspective may help researchers design quantum computers and other devices with improved efficiencies. [27]

This paper explains the magnetic effect of the superconductive current from the observed effects of the accelerating electrons, causing naturally the experienced changes of the electric field potential along the electric wire. The accelerating electrons explain not only the Maxwell Equations and the Special Relativity, but the Heisenberg Uncertainty Relation, the wave particle duality and the electron's spin also, building the bridge between the Classical and Quantum Theories.

The changing acceleration of the electrons explains the created negative electric field of the magnetic induction, the Higgs Field, the changing Relativistic Mass and the Gravitational Force, giving a Unified Theory of the physical forces. Taking into account the Planck Distribution Law of the electromagnetic oscillators also, we can explain the electron/proton mass rate and the Weak and Strong Interactions.

Since the superconductivity is basically a quantum mechanical phenomenon and some entangled particles give this opportunity to specific matters, like Cooper Pairs or other entanglements, as strongly correlated materials and Exciton-mediated electron pairing, we can say that the secret of superconductivity is the quantum entanglement.

Contents

The Quest of Superconductivity	3
Experiences and Theories	3
Double-transmon coupler will realize faster, more accurate superconducting quantum computers	3
Development background.....	4
Features of the new technology.....	5
Optical fiber could boost power of superconducting quantum computers	6
Ballistic graphene Josephson junctions enter microwave circuits	7
Superconducting qubits can function as quantum engines.....	9
Conventional superconductivity	10
Superconductivity and magnetic fields	10
Room-temperature superconductivity.....	11
Exciton-mediated electron pairing	11
Resonating valence bond theory	11
Strongly correlated materials	11
New superconductor theory may revolutionize electrical engineering	12
Unconventional superconductivity in $\text{Ba}^{0.6}\text{K}^{0.4}\text{Fe}^2\text{As}^2$ from inelastic neutron scattering	12
A grand unified theory of exotic superconductivity?	13
The role of magnetism	13
Concepts relating magnetic interactions, intertwined electronic orders, and strongly correlated superconductivity	13
Significance.....	14
Superconductivity's third side unmasked.....	14
Strongly correlated materials	15
Fermions and Bosons	15
The General Weak Interaction.....	15
Higgs Field and Superconductivity.....	15
Superconductivity and Quantum Entanglement	18
Conclusions.....	18
References:	18

Author: George Rajna

The Quest of Superconductivity

Superconductivity seems to contradict the theory of accelerating charges in the static electric current, caused by the electric force as a result of the electric potential difference, since a closed circle wire no potential difference at all. [1]

On the other hand the electron in the atom also moving in a circle around the proton with a constant velocity and constant impulse momentum with a constant magnetic field. This gives the idea of the centripetal acceleration of the moving charge in the closed circle wire as this is the case in the atomic electron attracted by the proton. Because of this we can think about superconductivity as a quantum phenomenon. [2]

Experiences and Theories

Double-transmon coupler will realize faster, more accurate superconducting quantum computers

Researchers at Toshiba Corporation have achieved a breakthrough in quantum computer architecture: the basic design for a double-transmon coupler that will improve the speed and accuracy of quantum computation in tunable couplers. The coupler is a key device in determining the performance of superconducting quantum computers.

Tunable couplers in a superconducting quantum computer link two qubits and perform quantum computations by turning on and off the coupling between them. Current technology can turn off the coupling of transmon qubits with close frequencies, but this is prone to crosstalk errors that occur on one of the qubits when the other qubit is irradiated with electromagnetic waves for control. In addition, current technology cannot completely turn off coupling for qubits with significantly different frequencies, resulting in errors due to residual coupling.

Toshiba has recently devised a double-transmon coupler that can completely turn on and off the coupling between qubits with significantly different frequencies. Completely turning on enables high-speed quantum computations with strong coupling, while completely turning off eliminates residual coupling, which improves quantum computation speeds and accuracy. Simulations with the new technology have shown it realizes two-qubit gates, basic operations in quantum computation, with an accuracy of 99.99% and a processing time of only 24 ns.

Toshiba's double-transmon coupler can be applied to fixed-frequency transmon qubits, realizing high stability and ease of design. It is the first to realize coupling between fixed-frequency transmon qubits with significantly different frequencies that can be completely switched on and off, and to deliver a high-speed, accurate two-qubit gate.

The technology is expected to advance the realization of higher-performance quantum computers that will contribute in such areas as the achievement of carbon neutrality and the development of new drugs. Details of the technology were published in *Physical Review Applied*.

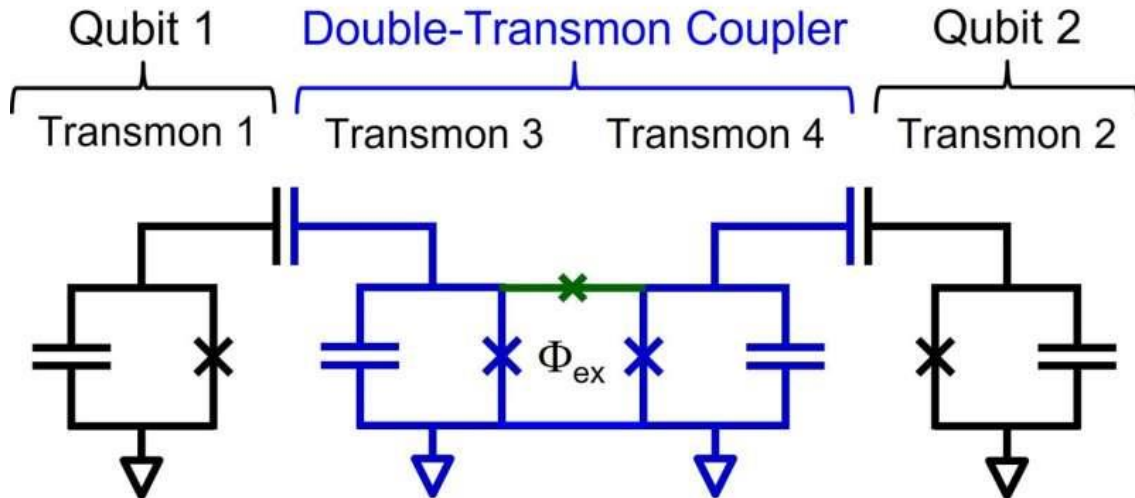

Circuit diagram of the double transmon coupler, a tunable coupler for superconducting qubits.
Credit: Toshiba Corporation

Development background

Quantum mechanics describes the invisible world of atoms and molecules using quantum superposition states, allowing a physical system to appear to be in two completely different states simultaneously. Quantum computers make use of this mysterious property to carry out computations that are practically impossible with conventional computers, a capability that has attracted much attention in recent years.

Quantum computers use qubits in quantum superposition states of 0 and 1 to execute computations. Any quantum computation is executed with two basic operations, single-qubit gates and two-qubit gates. To realize high-performance quantum computers, we need fast and accurate gate operations.

Development of quantum computers is being promoted worldwide, and this has seen the adoption of multiple approaches, with proposals ranging from the manipulation of single atoms or ions to the use of semiconductors and superconducting circuits. The superconducting circuit approach is now seen as having an advantage in terms of realizing quantum superposition states in large circuits, and in the relative ease of achieving the strong coupling of qubits essential for the high-speed execution of two-qubit gates.

Coupling of qubits is done with a coupler. Until recently, the mainstay devices have been fixed couplers with a constant coupling strength, but attention is now turning to tunable couplers, which are seen as offering the adjustable coupling strength necessary to improve performance.

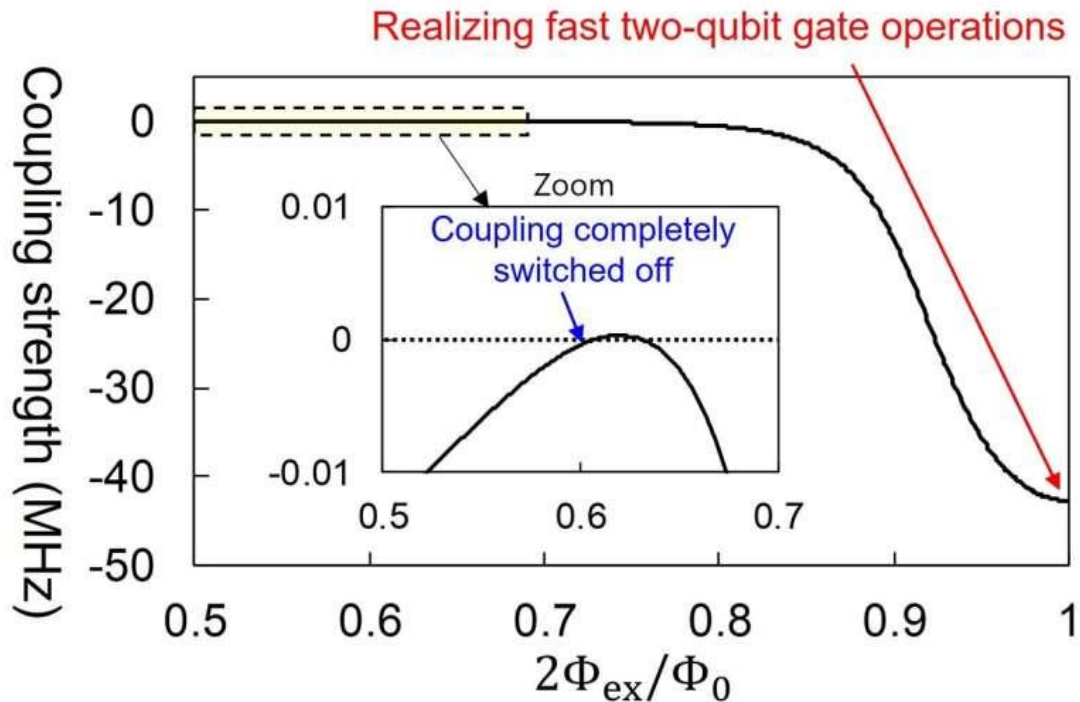

Magnetic flux dependence of coupling strength in double-transmon couplers. Credit: Toshiba Corporation

Tunable couplers achieve contradictory requirements: a fast two-qubit gate with strong coupling, along with the ability to reduce errors from residual coupling by switching off the coupling. Also, it is preferable that the qubit used in computations is a fixed-frequency transmon qubit, which is highly stable, has a simple structure and is easy to fabricate.

In addition, the frequency of the two qubits that are coupled should be significantly different, as this reduces crosstalk errors, and is robust against deviations from the design values of qubit frequencies, thereby improving yields in device fabrication. The problem here, however, is that no tunable coupler has yet been able to combine complete off-coupling and fast two-qubit gate operations for two fixed-frequency transmon qubits with significantly different frequencies.

Features of the new technology

Toshiba researchers have devised a double-transmon coupler, the world's first tunable coupler that can both completely turn off coupling and operate the two qubit gates at high speed for two fixed-frequency transmon qubits with significantly different frequencies.

The double transmon coupler comprises two fixed-frequency transmon qubits, along with two other fixed-frequency transmon qubits used for computation. The double-transmon coupler has one loop, and the three x's on the loop represent two transmon Josephson junctions and an additional Josephson junction. The magnetic flux in the loop, Φ_{ex} , can be tuned by an external magnetic field to bring the coupling strength between the qubits on both sides to exactly zero, completely switching off the coupling.

The coupling strength can also be increased to several tens of megahertz by increasing the magnetic flux, which realizes fast two-qubit gate operations. Simulations have shown

gate operations with an accuracy of 99.99% are possible, with gate times as short as 24 ns. The coupler is thus expected to contribute to higher-performance quantum computers. [30]

Optical fiber could boost power of superconducting quantum computers

The secret to building superconducting quantum computers with massive processing power may be an ordinary telecommunications technology—optical fiber.

Physicists at the National Institute of Standards and Technology (NIST) have measured and controlled a superconducting quantum bit (qubit) using light-conducting fiber instead of metal electrical wires, paving the way to packing a million qubits into a quantum computer rather than just a few thousand. The demonstration is described in the March 25 issue of *Nature*.

Superconducting circuits are a leading technology for making quantum computers because they are reliable and easily mass produced. But these circuits must operate at cryogenic temperatures, and schemes for wiring them to room-temperature electronics are complex and prone to overheating the qubits. A universal quantum computer, capable of solving any type of problem, is expected to need about 1 million qubits. Conventional cryostats—supercold dilution refrigerators—with metal wiring can only support thousands at the most.

Optical fiber, the backbone of telecommunications networks, has a glass or plastic core that can carry a high volume of light signals without conducting heat. But superconducting quantum computers use microwave pulses to store and process information. So the light needs to be converted precisely to microwaves.

To solve this problem, NIST researchers combined the fiber with a few other standard components that convert, convey and measure light at the level of single particles, or photons, which could then be easily converted into microwaves. The system worked as well as metal wiring and maintained the qubit's fragile quantum states.

"I think this advance will have high impact because it combines two totally different technologies, photonics and superconducting qubits, to solve a very important problem," NIST physicist John Teufel said. "Optical fiber can also carry far more data in a much smaller volume than conventional cable."

Normally, researchers generate microwave pulses at room temperature and then deliver them through coaxial metal cables to cryogenically maintained superconducting qubits. The new NIST setup used an optical fiber instead of metal to guide light signals to cryogenic photodetectors that converted signals back to microwaves and delivered them to the qubit. For experimental comparison purposes, microwaves could be routed to the qubit through either the photonic link or a regular coaxial line.

The "transmon" qubit used in the fiber experiment was a device known as a Josephson junction embedded in a three-dimensional reservoir or cavity. This junction consists of two superconducting metals separated by an insulator. Under certain conditions an electrical current can cross the junction and may oscillate back and forth. By applying a certain microwave frequency,

researchers can drive the qubit between low-energy and excited states (1 or 0 in digital computing). These states are based on the number of Cooper pairs—bound pairs of electrons with opposite properties—that have "tunneled" across the junction.

The NIST team conducted two types of experiments, using the photonic link to generate microwave pulses that either measured or controlled the quantum state of the qubit. The method is based on two relationships: The frequency at which microwaves naturally bounce back and forth in the cavity, called the resonance frequency, depends on the qubit state. And the frequency at which the qubit switches states depends on the number of photons in the cavity.

Researchers generally started the experiments with a microwave generator. To control the qubit's quantum state, devices called electro-optic modulators converted microwaves to higher optical frequencies. These light signals streamed through optical fiber from room temperature to 4K (minus 269 C or minus 452 F) down to 20 milliKelvin (thousandths of a Kelvin) where they landed in high-speed semiconductor photodetectors, which converted the light signals back to microwaves that were then sent to the quantum circuit.

In these experiments, researchers sent signals to the qubit at its natural resonance frequency, to put it into the desired quantum state. The qubit oscillated between its ground and excited states when there was adequate laser power.

To measure the qubit's state, researchers used an infrared laser to launch light at a specific power level through the modulators, fiber and photodetectors to measure the cavity's resonance frequency.

Researchers first started the qubit oscillating, with the laser power suppressed, and then used the photonic link to send a weak microwave pulse to the cavity. The cavity frequency accurately indicated the qubit's state 98% of the time, the same accuracy as obtained using the regular coaxial line.

The researchers envision a quantum processor in which in which light in optical fibers transmits signals to and from the qubits, with each fiber having the capacity to carry thousands of signals to and from the qubit. [29]

Ballistic graphene Josephson junctions enter microwave circuits

Superconducting quantum microwave circuits can function as qubits, the building blocks of a future quantum computer. A critical component of these circuits, the Josephson junction, is typically made using aluminium oxide. Researchers in the Quantum Nanoscience department at the Delft University of Technology have now successfully incorporated a graphene Josephson junction into a superconducting microwave circuit. Their work provides new insight into the interaction of superconductivity and graphene and its possibilities as a material for quantum technologies.

The essential building block of a quantum computer is the quantum bit, or qubit. Unlike regular bits, which can either be one or zero, qubits can be one, zero or a superposition of both these states. This last possibility, that bits can be in a superposition of two states at the same time, allows quantum computers to work in ways not possible with classical computers. The implications are profound: Quantum computers will be able to solve problems that will take a regular computer longer than the age of the universe to solve.

There are many ways to create qubits. One of the tried and tested methods is by using superconducting microwave circuits. These circuits can be engineered in such a way that they behave as harmonic oscillators "If we put a charge on one side, it will go through the inductor and oscillate back and forth," said Professor Gary Steele. "We make our qubits out of the different states of this charge bouncing back and forth."

An essential element of quantum microwave circuits is the so-called Josephson junction, which can, for example, consist of a non-superconducting material that separates two layers of superconducting material. Pairs of superconducting electrons can tunnel through this barrier, from one superconductor to the other, resulting in a supercurrent that can flow indefinitely long without any voltage applied.

In state-of-the-art Josephson junctions for quantum circuits, the weak link is a thin layer of aluminium oxide separating two aluminium electrodes. "However, these can only be tuned with the use of a magnetic field, potentially leading to cross-talk and on-chip heating, which can complicate their use in future applications," said Steele. Graphene offers a possible solution. It has proven to host robust supercurrents over micron distances that survive in magnetic fields of up to a few Tesla. However, these devices had thus far been limited to direct current (DC) applications. Applications in microwave circuits, such as qubits or parametric amplifiers, had not been explored.

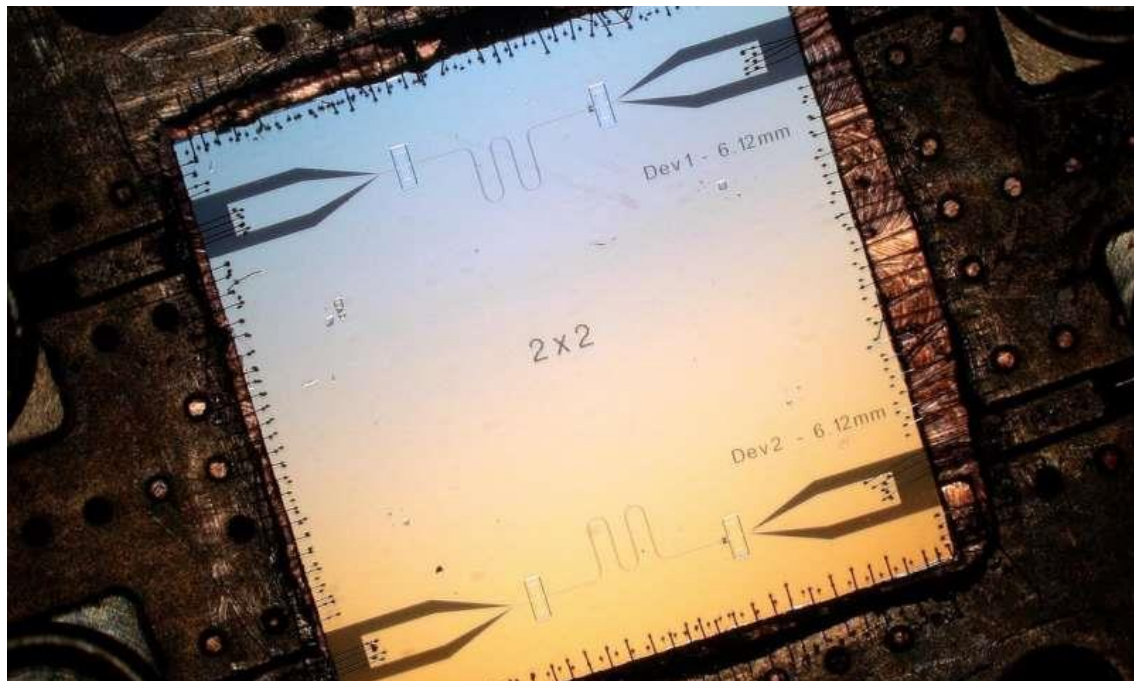

Close-up of the new a superconducting microwave circuit with a graphene Josephson junction.
Credit: TU Delft

The research team at Delft University of Technology incorporated a [graphene](#) Josephson junction into a superconducting microwave circuit. By characterizing their device in the DC regime, they showed that their graphene Josephson junction exhibits ballistic supercurrent that can be tuned by the use of a gate voltage, which prevents the device from heating up. Upon exciting the circuit with microwave radiation, the researchers directly observed the Josephson inductance of the junction, which had up to this point not been directly accessible in graphene superconducting devices.

The researchers believe that graphene Josephson junctions have the potential to play an important part in future quantum computers. "It remains to be seen if they can be made into viable qubits, however," said Steele. While the graphene junctions were good enough for building qubits, they were not as coherent as traditional quantum [microwave](#) circuits based on aluminium oxide junctions, so further development of the technology is required. However, in applications that don't require high coherence, gate tunability could be useful now. One such application is in amplifiers, which are also important in quantum infrastructure. Steele: "We are quite excited about using these devices for quantum amplifier applications."

The authors have made all of the data published in the manuscript available in an open repository, including the path all the way back to the data as it was measured from the instrument. In addition, the researchers released all of the software used for measuring the data, analysing the data, and making the plots in the figures under an open-source licence.

The results of the study have been published in *Nature Communications*. [28]

Superconducting qubits can function as quantum engines

Physicists have shown that superconducting circuits—circuits that have zero electrical resistance—can function as piston-like mechanical quantum engines. The new perspective may help researchers design quantum computers and other devices with improved efficiencies.

The physicists, Kewin Sachtleben, Kahio T. Mazon, and Luis G. C. Rego at the Federal University of Santa Catarina in Florianópolis, Brazil, have published a paper on their work on superconducting qubits in a recent issue of *Physical Review Letters*.

In their study, the physicists explain that superconducting circuits are functionally equivalent to quantum systems in which quantum particles tunnel in a double-quantum well. These wells have the ability to oscillate, meaning the width of the well changes repeatedly. When this happens, the system behaves somewhat like a piston that moves up and down in a cylinder, which changes the volume of the cylinder. This oscillatory behavior allows work to be performed on the system. The researchers show that, in the double-quantum well, part of this work comes from quantum coherent dynamics, which creates friction that decreases the work output. These results provide a better understanding of the connection between quantum and classical thermodynamic work.

"The distinction between 'classical' thermodynamic work, responsible for population transfer, and a quantum component, responsible for creating coherences, is an important result," Mazon told

Phys.org. "The creation of coherences, in turn, generates a similar effect to friction, causing a notcompletely-reversible operation of the engine. In our work we have been able to calculate the reaction force caused on the quantum piston wall due to the creation of coherences. In principle this force can be measured, thus constituting the experimental possibility of observing the emergence of coherences during the operation of the quantum engine."

One of the potential benefits of viewing superconducting qubits as quantum engines is that it may allow researchers to incorporate quantum coherent dynamics into future technologies, in particular quantum computers. The physicists explain that a similar behavior can be seen in nature, where quantum coherences improve the efficiency of processes such as photosynthesis, light sensing, and other natural processes.

"Quantum machines may have applications in the field of quantum information, where the energy of quantum coherences is used to perform information manipulation in the quantum regime," Mazon said. "It is worth remembering that even photosynthesis can be described according to the working principles of a quantum machine, so unraveling the mysteries of quantum thermodynamics can help us to better understand and interpret various natural processes." [27]

Conventional superconductivity

Conventional superconductivity can be explained by a theory developed by Bardeen, Cooper and Schrieffer (BCS) in 1957. In BCS theory, electrons in a superconductor combine to form pairs, called Cooper pairs, which are able to move through the crystal lattice without resistance when an electric voltage is applied. Even when the voltage is removed, the current continues to flow indefinitely, the most remarkable property of superconductivity, and one that explains the keen interest in their technological potential. [3]

High-temperature superconductivity

In 1986, high-temperature superconductivity was discovered (i.e. superconductivity at temperatures considerably above the previous limit of about 30 K; up to about 130 K). It is believed that BCS theory alone cannot explain this phenomenon and that other effects are at play. These effects are still not yet fully understood; it is possible that they even control superconductivity at low temperatures for some materials. [8]

Superconductivity and magnetic fields

Superconductivity and magnetic fields are normally seen as rivals – very strong magnetic fields normally destroy the superconducting state. Physicists at the Paul Scherer Institute have now demonstrated that a novel superconducting state is only created in the material CeCoIn_5 when there are strong external magnetic fields. This state can then be manipulated by modifying the field direction. The material is already superconducting in weaker fields, too. In strong fields, however, an additional second superconducting state is created which means that there are two different superconducting states at the same time in the same material. The new state is coupled with an anti-ferromagnetic order that appears simultaneously with the field. The anti-ferromagnetic order from whose properties the researchers have deduced the existence of the superconducting state was detected with neutrons at PSI and at the Institute Laue-Langevin in Grenoble. [6]

Room-temperature superconductivity

After more than twenty years of intensive research the origin of high-temperature superconductivity is still not clear, but it seems that instead of *electron-phonon* attraction mechanisms, as in conventional superconductivity, one is dealing with genuine *electronic* mechanisms (e.g. by antiferromagnetic correlations), and instead of s-wave pairing, d-waves are substantial. One goal of all this research is room-temperature superconductivity. [9]

Exciton-mediated electron pairing

Theoretical work by Neil Ashcroft predicted that solid metallic hydrogen at extremely high pressure (~500 GPa) should become superconducting at approximately room-temperature because of its extremely high speed of sound and expected strong coupling between the conduction electrons and the lattice vibrations (phonons). This prediction is yet to be experimentally verified, as yet the pressure to achieve metallic hydrogen is not known but may be of the order of 500 GPa. In 1964, William A. Little proposed the possibility of high temperature superconductivity in organic polymers. This proposal is based on the exciton-mediated electron pairing, as opposed to phonon-mediated pairing in BCS theory. [9]

Resonating valence bond theory

In condensed matter physics, the resonating valence bond theory (RVB) is a theoretical model that attempts to describe high temperature superconductivity, and in particular the superconductivity in cuprate compounds. It was first proposed by American physicist P. W. Anderson and the Indian theoretical physicist Ganapathy Baskaran in 1987. The theory states that in copper oxide lattices, electrons from neighboring copper atoms interact to form a valence bond, which locks them in place. However, with doping, these electrons can act as mobile Cooper pairs and are able to superconduct. Anderson observed in his 1987 paper that the origins of superconductivity in doped cuprates was in the Mott insulator nature of crystalline copper oxide. RVB builds on the Hubbard and t-J models used in the study of strongly correlated materials. [10]

Strongly correlated materials

Strongly correlated materials are a wide class of electronic materials that show unusual (often technologically useful) electronic and magnetic properties, such as metal-insulator transitions or half-metallicity. The essential feature that defines these materials is that the behavior of their electrons cannot be described effectively in terms of non-interacting entities. Theoretical models of the electronic structure of strongly correlated materials must include electronic correlation to be accurate. Many transition metal oxides belong into this class which may be subdivided according to their behavior, e.g. high- T_c , spintronic materials, Mott insulators, spin Peierls materials, heavy fermion materials, quasi-low-dimensional materials, etc. The single most intensively studied effect is probably high-temperature superconductivity in doped cuprates, e.g. $\text{La}_{2-x}\text{Sr}_x\text{CuO}_4$. Other ordering or magnetic phenomena and temperature-induced phase transitions in many transition-metal oxides are also gathered under the term "strongly correlated materials." Typically, strongly correlated materials have incompletely filled *d*- or *f*-electron shells with narrow energy bands. One can no longer consider any electron in the material as being in a "sea" of the averaged motion of the others (also known as mean field theory). Each single electron has a complex influence on its neighbors.

[11]

New superconductor theory may revolutionize electrical engineering

High-temperature superconductors exhibit a frustratingly varied catalog of odd behavior, such as electrons that arrange themselves into stripes or refuse to arrange themselves symmetrically around atoms. Now two physicists propose that such behaviors – and superconductivity itself – can all be traced to a single starting point, and they explain why there are so many variations.

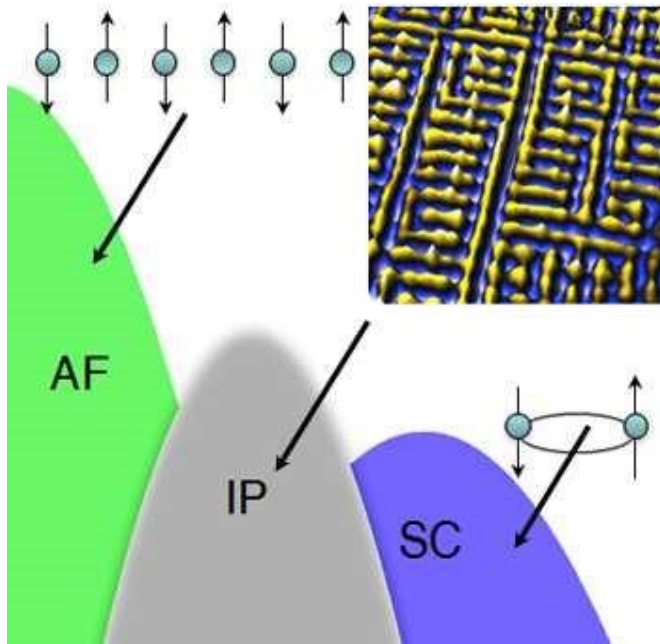

An "antiferromagnetic" state, where the magnetic moments of electrons are opposed, can lead to a variety of unexpected arrangements of electrons in a high-temperature superconductor, then finally to the formation of "Cooper pairs" that conduct without resistance, according to a new theory. [22]

Unconventional superconductivity in $\text{Ba}^{0.6}\text{K}^{0.4}\text{Fe}_2\text{As}_2$ from inelastic neutron scattering

In BCS superconductors, the energy gap between the superconducting and normal electronic states is constant, but in unconventional superconductors the gap varies with the direction the electrons are moving. In some directions, the gap may be zero. The puzzle is that the gap does not seem to vary with direction in the iron arsenides. Theorists have argued that, while the size of the gap shows no directional dependence in these new compounds, the sign of the gap is opposite for different electronic states. The standard techniques to measure the gap, such as photoemission, are not sensitive to this change in sign.

But inelastic neutron scattering is sensitive. Osborn, along with Argonne physicist Stephan Rosenkranz, led an international collaboration to perform neutron experiments using samples of

the new compounds made in Argonne's Materials Science Division, and discovered a magnetic excitation in the superconducting state that can only exist if the energy gap changes sign from one electron orbital to another.

"Our results suggest that the mechanism that makes electrons pair together could be provided by antiferromagnetic fluctuations rather than lattice vibrations," Rosenkranz said. "It certainly gives direct evidence that the superconductivity is unconventional."

Inelastic neutron scattering continues to be an important tool in identifying unconventional superconductivity, not only in the iron arsenides, but also in new families of superconductors that may be discovered in the future. [23]

A grand unified theory of exotic superconductivity?

The role of magnetism

In all known types of high-T_c superconductors—copper-based (cuprate), iron-based, and so-called heavy fermion compounds—superconductivity emerges from the "extinction" of antiferromagnetism, the ordered arrangement of electrons on adjacent atoms having anti-aligned spin directions. Electrons arrayed like tiny magnets in this alternating spin pattern are at their lowest energy state, but this antiferromagnetic order is not beneficial to superconductivity.

However if the interactions between electrons that cause antiferromagnetic order can be maintained while the actual order itself is prevented, then superconductivity can appear. "In this situation, whenever one electron approaches another electron, it tries to anti-align its magnetic state," Davis said. Even if the electrons never achieve antiferromagnetic order, these antiferromagnetic interactions exert the dominant influence on the behavior of the material. "This antiferromagnetic influence is universal across all these types of materials," Davis said.

Many scientists have proposed that these antiferromagnetic interactions play a role in the ability of electrons to eventually pair up with anti-aligned spins—a condition necessary for them to carry current with no resistance. The complicating factor has been the existence of many different types of "intertwined" electronic phases that also emerge in the different types of high-T_c superconductors—sometimes appearing to compete with superconductivity and sometimes coexisting with it. [24]

Concepts relating magnetic interactions, intertwined electronic orders, and strongly correlated superconductivity

Unconventional superconductivity (SC) is said to occur when Cooper pair formation is dominated by repulsive electron–electron interactions, so that the symmetry of the pair wave function is other than an isotropic s-wave. The strong, on-site, repulsive electron–electron interactions that are the proximate cause of such SC are more typically drivers of commensurate magnetism. Indeed, it is the suppression of commensurate antiferromagnetism (AF) that usually allows this type of unconventional superconductivity to emerge. Importantly, however, intervening between

these AF and SC phases, intertwined electronic ordered phases (IP) of an unexpected nature are frequently discovered. For this reason, it has been extremely difficult to distinguish the microscopic essence of the correlated superconductivity from the often spectacular phenomenology of the IPs. Here we introduce a model conceptual framework within which to understand the relationship between AF electron–electron interactions, IPs, and correlated SC. We demonstrate its effectiveness in simultaneously explaining the consequences of AF interactions for the copper-based, iron-based, and heavy-fermion superconductors, as well as for their quite distinct IPs.

Significance

This study describes a unified theory explaining the rich ordering phenomena, each associated with a different symmetry breaking, that often accompany high-temperature superconductivity. The essence of this theory is an "antiferromagnetic interaction," the interaction that favors the development of magnetic order where the magnetic moments reverse direction from one crystal unit cell to the next. We apply this theory to explain the superconductivity, as well as all observed accompanying ordering phenomena in the copper-oxide superconductors, the iron-based superconductors, and the heavy fermion superconductors. [25]

Superconductivity's third side unmasked

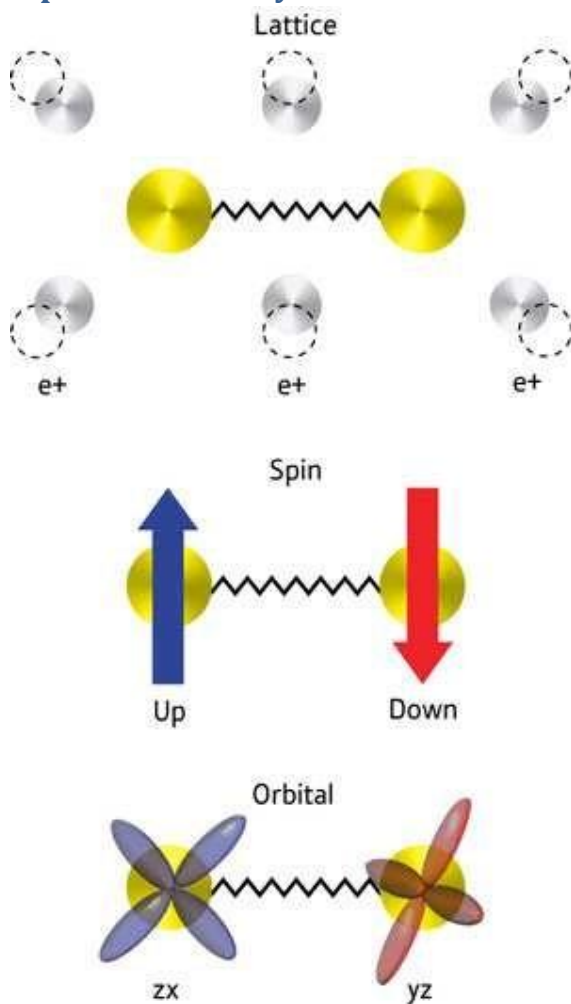

Shimajima and colleagues were surprised to discover that interactions between electron spins do not cause the electrons to form Cooper pairs in the pnictides. Instead, the coupling is mediated by the electron clouds surrounding the atomic cores. Some of these so-called orbitals have the same energy, which causes interactions and electron fluctuations that are sufficiently strong to mediate superconductivity.

This could spur the discovery of new superconductors based on this mechanism. "Our work establishes the electron orbitals as a third kind of pairing glue for electron pairs in superconductors, next to lattice vibrations and electron spins," explains Shimajima. "We believe that this finding is a step towards the dream of achieving room-temperature superconductivity," he concludes. [17]

Strongly correlated materials

Strongly correlated materials give us the idea of diffraction patterns explaining the electron-proton mass ratio. [13]

This explains the theories relating the superconductivity with the strong interaction. [14]

Fermions and Bosons

The fermions are the diffraction patterns of the bosons such a way that they are both sides of the same thing. We can generalize the weak interaction on all of the decaying matter constructions, even on the biological too.

The General Weak Interaction

The Weak Interactions T-asymmetry is in conjunction with the T-asymmetry of the Second Law of Thermodynamics, meaning that locally lowering entropy (on extremely high temperature) causes for example the Hydrogen fusion. The arrow of time by the Second Law of Thermodynamics shows the increasing entropy and decreasing information by the Weak Interaction, changing the temperature dependent diffraction patterns. The Fluctuation Theorem says that there is a probability that entropy will flow in a direction opposite to that dictated by the Second Law of Thermodynamics. In this case the Information is growing that is the matter formulas are emerging from the chaos. [18] One of these new matter formulas is the superconducting matter.

Higgs Field and Superconductivity

The simplest implementation of the mechanism adds an extra Higgs field to the gauge theory. The specific spontaneous symmetry breaking of the underlying local symmetry, which is similar to that one appearing in the theory of superconductivity, triggers conversion of the longitudinal field component to the Higgs boson, which interacts with itself and (at least of part of) the other fields in the theory, so as to produce mass terms for the above-mentioned three gauge bosons, and also to the above-mentioned fermions (see below). [16]

The Higgs mechanism occurs whenever a charged field has a vacuum expectation value. In the nonrelativistic context, this is the Landau model of a charged Bose–Einstein condensate, also

known as a superconductor. In the relativistic condensate, the condensate is a scalar field, and is relativistically invariant.

The Higgs mechanism is a type of superconductivity which occurs in the vacuum. It occurs when all of space is filled with a sea of particles which are charged, or, in field language, when a charged field has a nonzero vacuum expectation value. Interaction with the quantum fluid filling the space prevents certain forces from propagating over long distances (as it does in a superconducting medium; e.g., in the Ginzburg–Landau theory).

A superconductor expels all magnetic fields from its interior, a phenomenon known as the Meissner effect. This was mysterious for a long time, because it implies that electromagnetic forces somehow become short-range inside the superconductor. Contrast this with the behavior of an ordinary metal. In a metal, the conductivity shields electric fields by rearranging charges on the surface until the total field cancels in the interior. But magnetic fields can penetrate to any distance, and if a magnetic monopole (an isolated magnetic pole) is surrounded by a metal the field can escape without collimating into a string. In a superconductor, however, electric charges move with no dissipation, and this allows for permanent surface currents, not just surface charges. When magnetic fields are introduced at the boundary of a superconductor, they produce surface currents which exactly

neutralize them. The Meissner effect is due to currents in a thin surface layer, whose thickness, the London penetration depth, can be calculated from a simple model (the Ginzburg–Landau theory).

This simple model treats superconductivity as a charged Bose–Einstein condensate. Suppose that a superconductor contains bosons with charge q . The wavefunction of the bosons can be described by introducing a quantum field, ψ , which obeys the Schrödinger equation as a field equation (in units where the reduced Planck constant, \hbar , is set to 1):

$$i \frac{\partial}{\partial t} \psi = \frac{(\nabla - iqA)^2}{2m} \psi.$$

The operator $\psi(x)$ annihilates a boson at the point x , while its adjoint ψ^\dagger creates a new boson at the same point. The wavefunction of the Bose–Einstein condensate is then the expectation value ψ of $\psi(x)$, which is a classical function that obeys the same equation. The interpretation of the expectation value is that it is the phase that one should give to a newly created boson so that it will coherently superpose with all the other bosons already in the condensate.

When there is a charged condensate, the electromagnetic interactions are screened. To see this, consider the effect of a gauge transformation on the field. A gauge transformation rotates the phase of the condensate by an amount which changes from point to point, and shifts the vector potential by a gradient:

$$\psi \rightarrow e^{iq\phi(x)} \psi$$

$$A \rightarrow A + \nabla\phi.$$

When there is no condensate, this transformation only changes the definition of the phase of ψ at every point. But when there is a condensate, the phase of the condensate defines a preferred choice of phase.

The condensate wave function can be written as

$$\psi(x) = \rho(x) e^{i\theta(x)},$$

where ρ is real amplitude, which determines the local density of the condensate. If the condensate were neutral, the flow would be along the gradients of θ , the direction in which the phase of the Schrödinger field changes. If the phase θ changes slowly, the flow is slow and has very little energy. But now θ can be made equal to zero just by making a gauge transformation to rotate the phase of the field.

The energy of slow changes of phase can be calculated from the Schrödinger kinetic energy,

$$H = \frac{1}{2m} |(qA + \nabla)\psi|^2,$$

and taking the density of the condensate ρ to be constant,

$$H \approx \frac{\rho^2}{2m} (qA + \nabla\theta)^2.$$

Fixing the choice of gauge so that the condensate has the same phase everywhere, the electromagnetic field energy has an extra term,

$$\frac{q^2 \rho^2}{2m} A^2.$$

When this term is present, electromagnetic interactions become short-ranged. Every field mode, no matter how long the wavelength, oscillates with a nonzero frequency. The lowest frequency can be read off from the energy of a long wavelength A mode,

$$E \approx \frac{\dot{A}^2}{2} + \frac{q^2 \rho^2}{2m} A^2.$$

This is a harmonic oscillator with frequency

$$\sqrt{\frac{1}{m} q^2 \rho^2}.$$

The quantity $|\psi|^2 (= \rho^2)$ is the density of the condensate of superconducting particles.

In an actual superconductor, the charged particles are electrons, which are fermions not bosons. So in order to have superconductivity, the electrons need to somehow bind into Cooper pairs. [12]

The charge of the condensate q is therefore twice the electron charge e . The pairing in a normal superconductor is due to lattice vibrations, and is in fact very weak; this means that the pairs are very loosely bound. The description of a Bose–Einstein condensate of loosely bound pairs is

actually more difficult than the description of a condensate of elementary particles, and was only worked out in 1957 by Bardeen, Cooper and Schrieffer in the famous BCS theory. [3]

Superconductivity and Quantum Entanglement

We have seen that the superconductivity is basically a quantum mechanical phenomenon and some entangled particles give this opportunity to specific matters, like Cooper Pairs or other entanglements, as strongly correlated materials and Exciton-mediated electron pairing. [26]

Conclusions

Probably in the superconductivity there is no electric current at all, but a permanent magnetic field as the result of the electron's spin in the same direction in the case of the circular wire on a low temperature. [6]

We think that there is an electric current since we measure a magnetic field. Because of this saying that the superconductivity is a quantum mechanical phenomenon.

Since the acceleration of the electrons is centripetal in a circular wire, in the atom or in the spin, there is a steady current and no electromagnetic induction. This way there is no changing in the Higgs field, since it needs a changing acceleration. [18]

The superconductivity is temperature dependent; it means that the General Weak Interaction is very relevant to create this quantum state of the matter. [19]

We have seen that the superconductivity is basically a quantum mechanical phenomenon and some entangled particles give this opportunity to specific matters, like Cooper Pairs or other entanglements. [26]

References:

- [1] [https://www.academia.edu/3833335/The Magnetic field of the Electric current](https://www.academia.edu/3833335/The_Magnetic_field_of_the_Electric_current)
- [2] [https://www.academia.edu/4239860/The Bridge between Classical and Quantum Mechanics](https://www.academia.edu/4239860/The_Bridge_between_Classical_and_Quantum_Mechanics)
- [3] http://en.wikipedia.org/wiki/BCS_theory
- [4] http://en.wikipedia.org/wiki/Meissner_effect#cite_note-3
- [5] http://en.wikipedia.org/wiki/London_equations

- [6] Superconductivity switched on by magnetic field <http://phys.org/news/2013-12-superconductivity-magnetic-field.html#jCp>
- [7] <http://en.wikipedia.org/wiki/Superconductivity>
- [8] http://en.wikipedia.org/wiki/High-temperature_superconductivity
- [9] http://en.wikipedia.org/wiki/Room-temperature_superconductor
- [10] http://en.wikipedia.org/wiki/Resonating_valence_bond_theory
- [11] http://en.wikipedia.org/wiki/Strongly_correlated_material
- [12] http://en.wikipedia.org/wiki/Cooper_pair
- [13] https://www.academia.edu/3834454/3_Dimensional_String_Theory
- [14] http://en.wikipedia.org/wiki/Color_superconductivity
- [15] http://en.wikipedia.org/wiki/Fermi_surface
- [16] http://en.wikipedia.org/wiki/Higgs_mechanism
- [17] Superconductivity's third side unmasked <http://phys.org/news/2011-06-superconductivity-side-unmasked.html#nRlv>
- [18] https://www.academia.edu/4158863/Higgs_Field_and_Quantum_Gravity
- [19] https://www.academia.edu/4221717/General_Weak_Interaction
- [20] Einstein on Superconductivity <http://arxiv.org/pdf/physics/0510251/>
- [21] Conventional Superconductivity <http://phys.org/news150729937.html#jCp>
- [22] <http://phys.org/news/2013-12-superconductor-theory-revolutionize-electrical.html#jCp>
- [23] <http://phys.org/news150729937.html#jCp>
- [24] <http://phys.org/news/2013-10-grand-theory-exotic-superconductivity.html#jCp>
- [25] <http://www.pnas.org/content/early/2013/10/09/1316512110.full.pdf+html>
- [26] The Secret of Quantum Entanglement
https://www.academia.edu/7229968/The_Secret_of_Quantum_Entanglement
- [27] Superconducting qubits can function as quantum engines <https://phys.org/news/2017-10-superconducting-qubits-function-quantum.html>
- [28] Ballistic graphene Josephson junctions enter microwave circuits

<https://phys.org/news/2018-10-ballistic-graphene-josephson-junctions-microwave.html>

[29] Optical fiber could boost power of superconducting quantum computers

<https://phys.org/news/2021-03-optical-fiber-boost-power-superconducting.html>

[30] Double-transmon coupler will realize faster, more accurate superconducting quantum computers

<https://phys.org/news/2022-09-double-transmon-coupler-faster-accurate-superconducting.html>