

TOP VIEW - LEVELING FEET/CASTER LOCATION

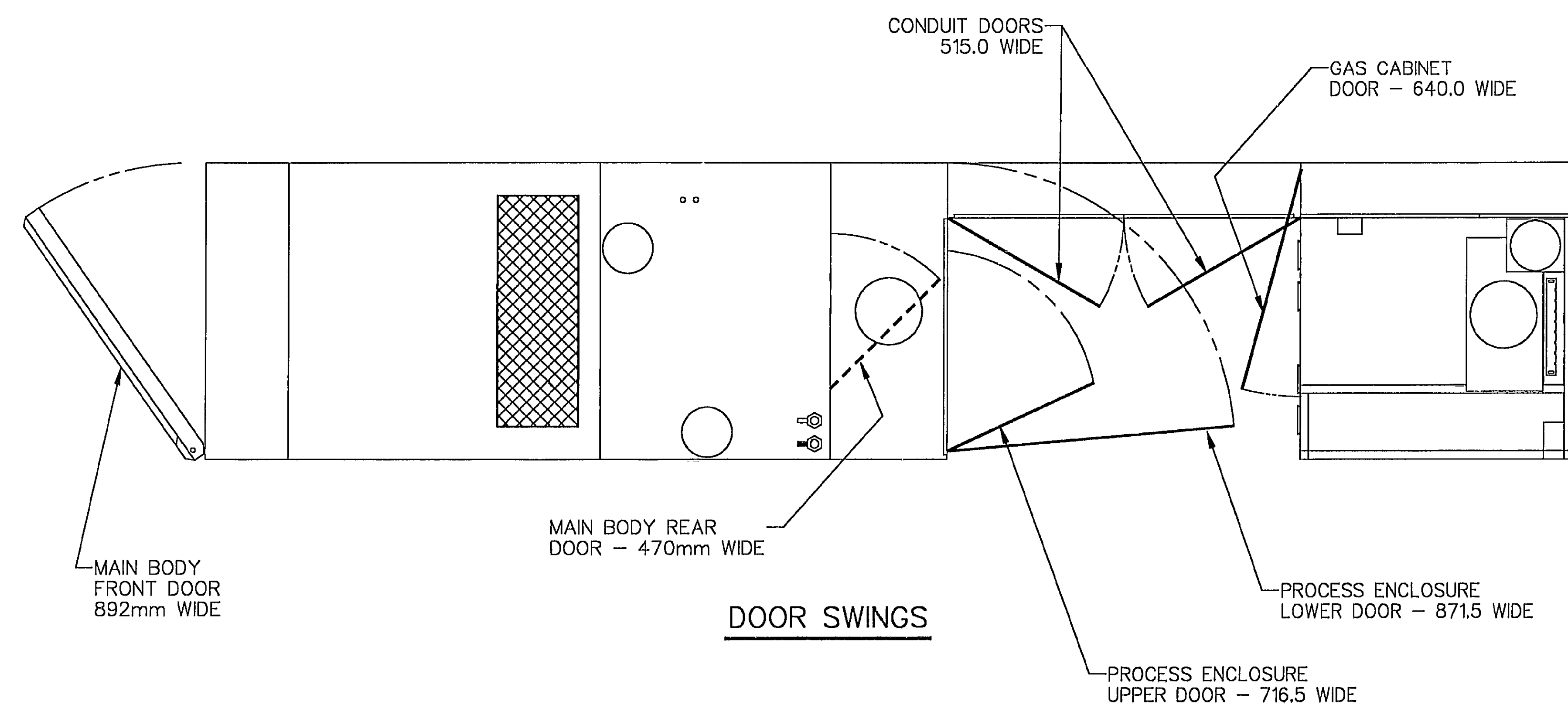

DOOR SWINGS

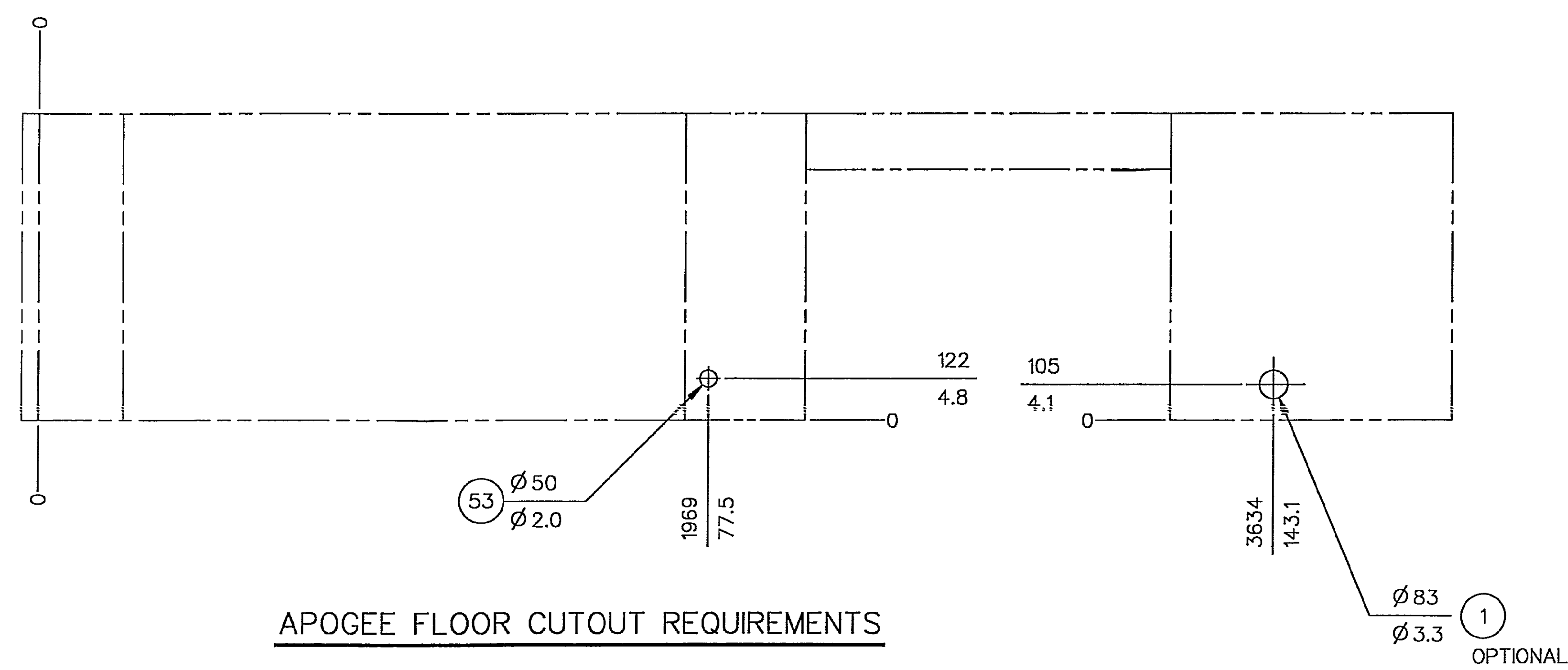

APOGEE FLOOR CUTOUT REQUIREMENTS

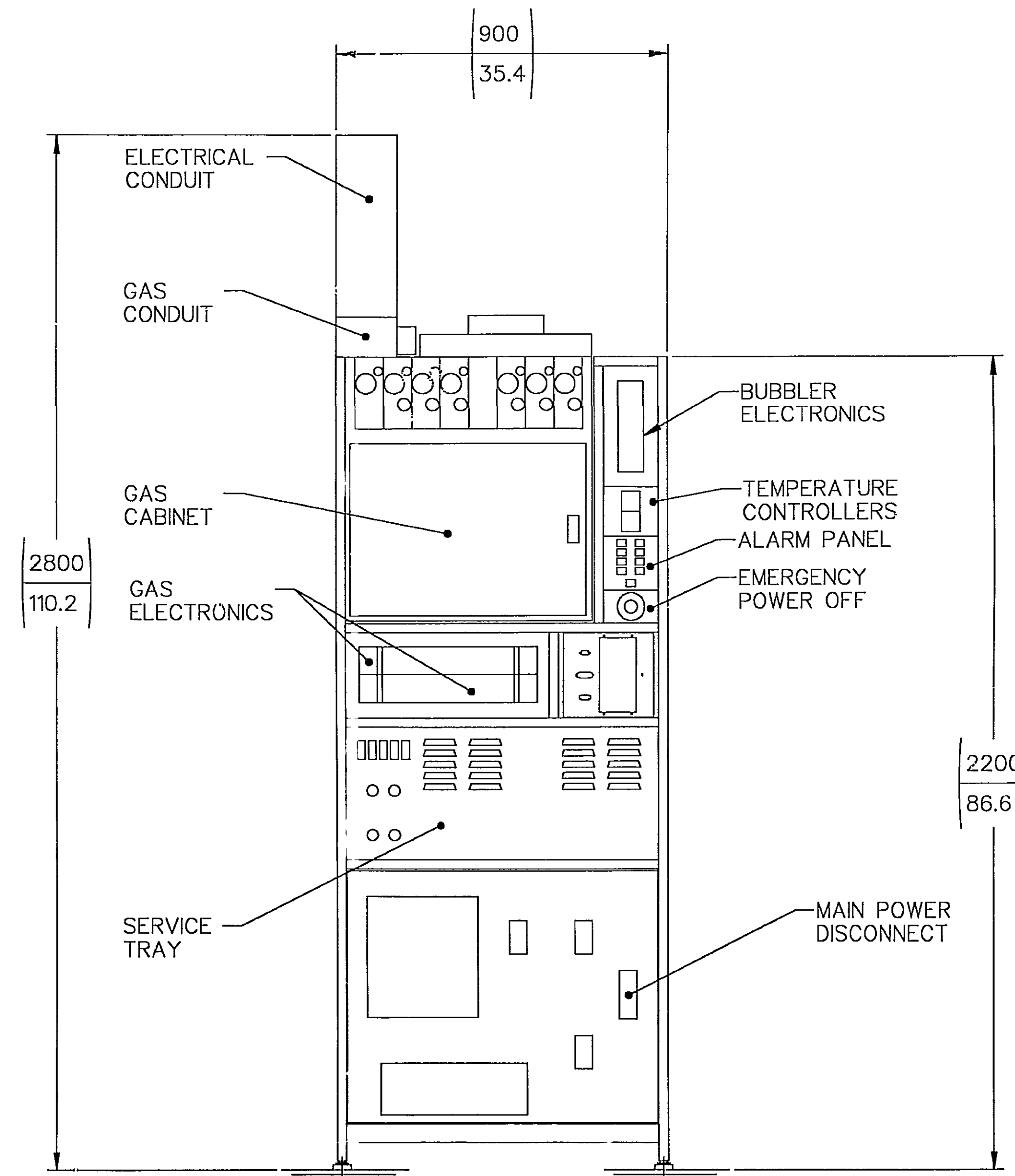

VIEW A-A

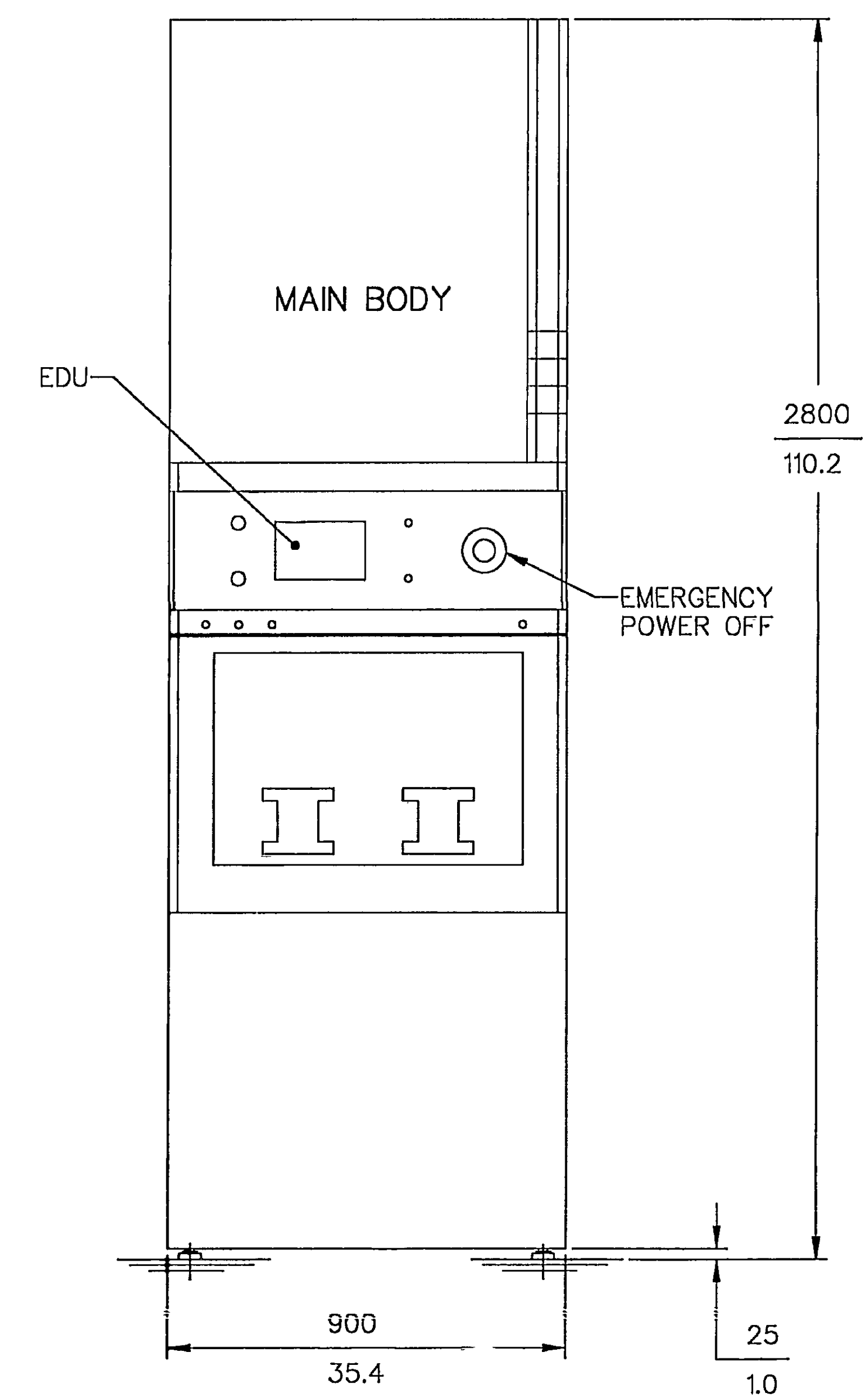

VIEW D-D

FRONT VIEW (clean room side)

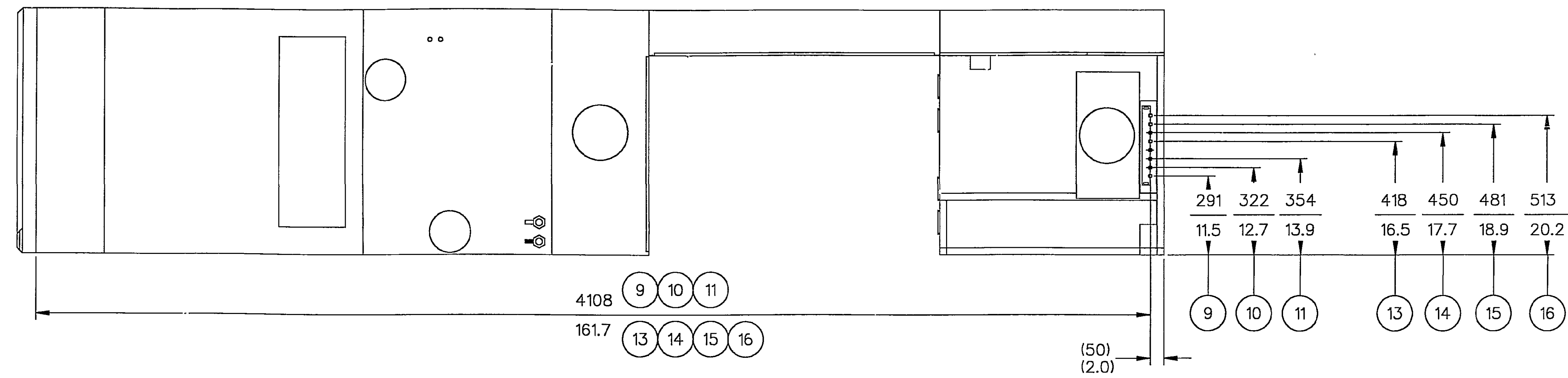

VIEW F-F

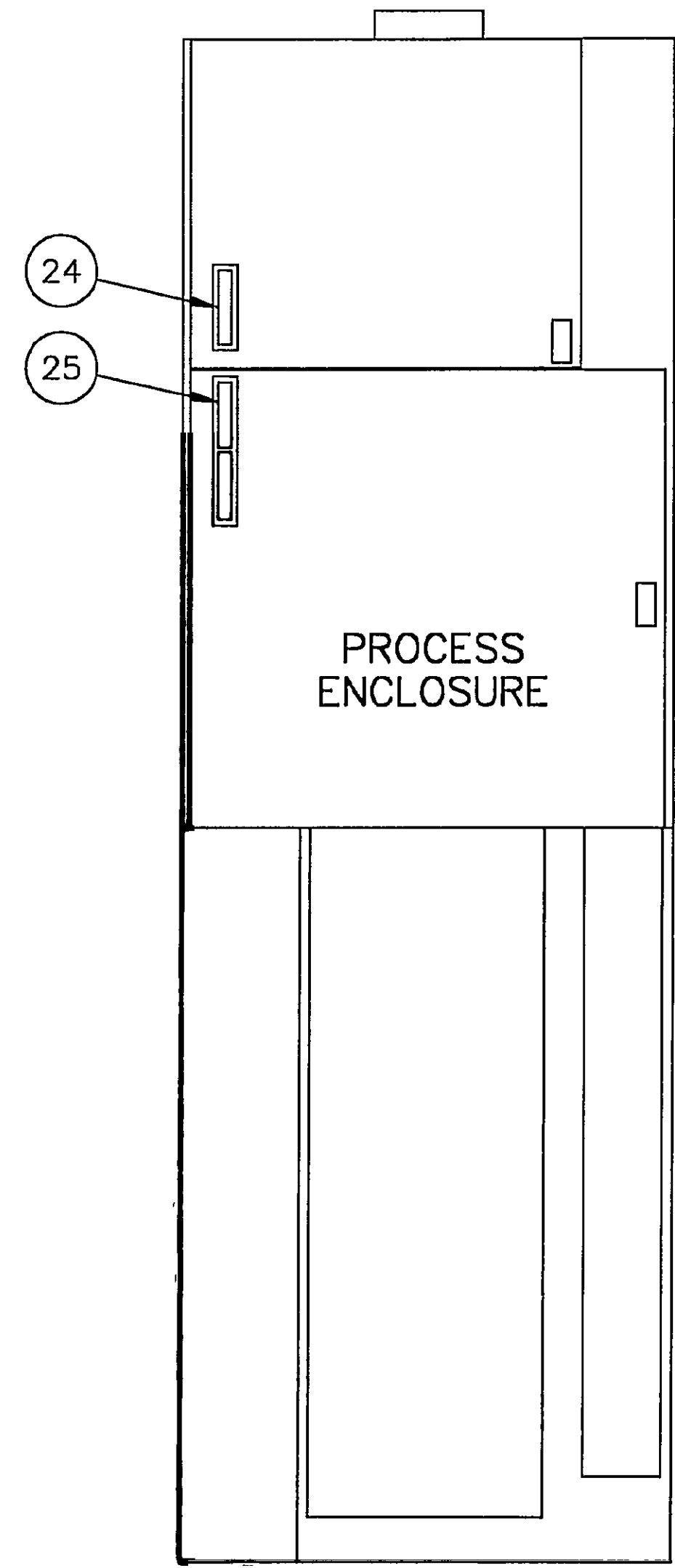

VIEW E-E

