



PHOTOMASK EQUIPMENT

SUSS HMx Series

PHOTOMASK AND WAFER PROCESSING SYSTEM





PHOTOMASK EQUIPMENT

SUSS HMx Series

PHOTOMASK AND WAFER PROCESSING SYSTEM

The HMx Square is designed to address the needs of customers in the semiconductor industry requiring high quality substrate processing for photomask applications as well as opto-electronics, OLED, and special semiconductor back-end (MEMS) applications. It offers develop, etch and cleaning functionalities.

The HMx Square enables processing of small series or pilot production of special substrates. The system is loaded manually. All further process steps are automated.

The HMx Square series features state-of-the-art electronic control and software systems with the latest environmental and safety upgrades for safe processing of the most sensitive substrates. With comprehensive photomask processing and a broad range of substrate handling options, the HMx Square offers an ideal solution for R&D and pilot production, as well as small lot processing of special substrates. The HMx Square design incorporates the latest cleaning techniques compliant with modern cleanroom design making it a low risk back-up system for advanced processing.

HIGHLIGHTS

- + Semi-automated (manual loading)
- + Qualified for >1 μm technology nodes
- + High uptime and low CoO
- + Certified by CE and SEMI
- + Proven performance evolving over 25 years



HMx Square	9" TYPE	14" TYPE
Dimensions	w: 960 mm (1.260) x d: 1.134 mm x h: 1.490 mm (1.833)	w: 1.477 mm x d: 1.426 mm x h: 1.824 mm
Applications	Clean / re-clean / resist strip Wet etch / wet develop	Clean / re-clean / resist strip Wet etch / wet develop
Substrates	50 mm – 200 mm (round) 3 inch – 9 inch (square) piece chuck	100 mm – 300 mm (round) 5 inch – 14 inch (square) others on request

PHOTOMASK EQUIPMENT

SUSS HMx Series

PHOTOMASK AND WAFER PROCESSING SYSTEM

	CLEAN	DEVELOP/ ETCH
STANDARD FEATURES		
Front-side Rinse: 1x2 Nozzle	✓	✓
Back-side Rinse: 1x2 Nozzles, 1x1 Nozzle	✓	✓
Chamber Rinse: 3 Nozzles	✓	✓
DI-CO ₂ Ionization	✓	✓
SPM-Dispense	✓	Optional
Full Jet Spray	✓	Optional
Ultra-Pure Quartz Glass Heater (Hot DI water)	✓	Optional
DI NH ₄ OH Ionization	✓	
2x1 Fan Nozzle (Develop/Etch)		✓
ADVANCED FEATURES		
Automatic Refill	Optional	Optional
Megasonics	Optional	
PVA Sponge Brush	Optional	
SC-1 Cleaning	Optional	
SC-2 Cleaning	Optional	
ETFE Tanks	Optional	Optional

SAFETY FEATURES

- + Design according to SEMI S1-0701E, S2-0706D, S8-0308, S13-0305 and CE standards
- + Media leak and exhaust detection with hardware interlocks to media dispense
- + Hardware interlocks for all safety relevant sensor conditions, e.g. leak, exhaust, safety shields, heated bath level, media heater temperature, etc.

Optional Autofill
Media Cabinet

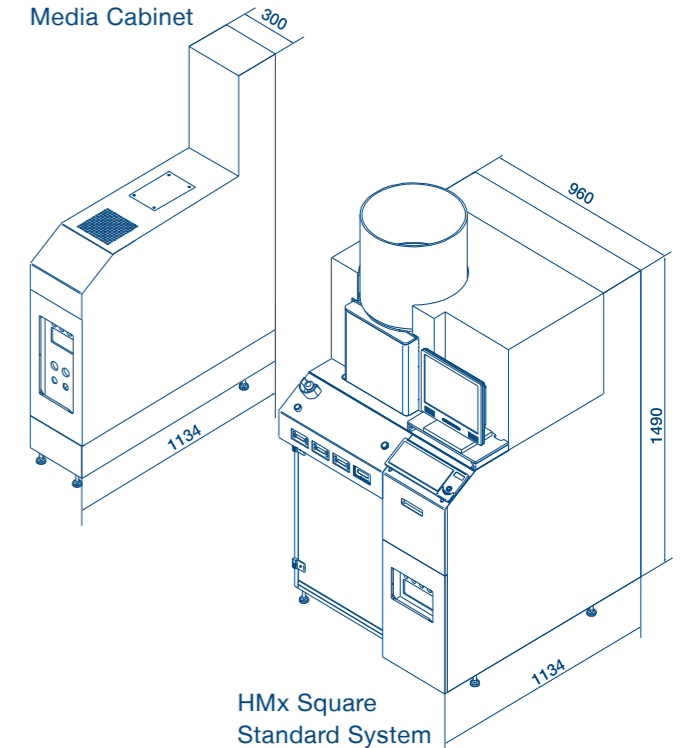

- + Customized hardware interlocks to prevent dispense of non-compatible process media specification
- + Double-contained dispense systems
- + Ergonomic design of chemical storage areas
- + FM-4910 approved design/material optionally available

Data, design and specification depend on individual process conditions and can vary according to equipment configurations. Not all specifications may be valid simultaneously. Illustrations, photos and specifications in this brochure are not legally binding. SUSS MicroTec reserves the right to change machine specifications without prior notice.

NORTH AMERICA

■ USA

EUROPE

■ Germany ■ France
■ Switzerland ■ United Kingdom

ASIA

■ Japan ■ China ■ Singapore
■ Korea ■ Taiwan

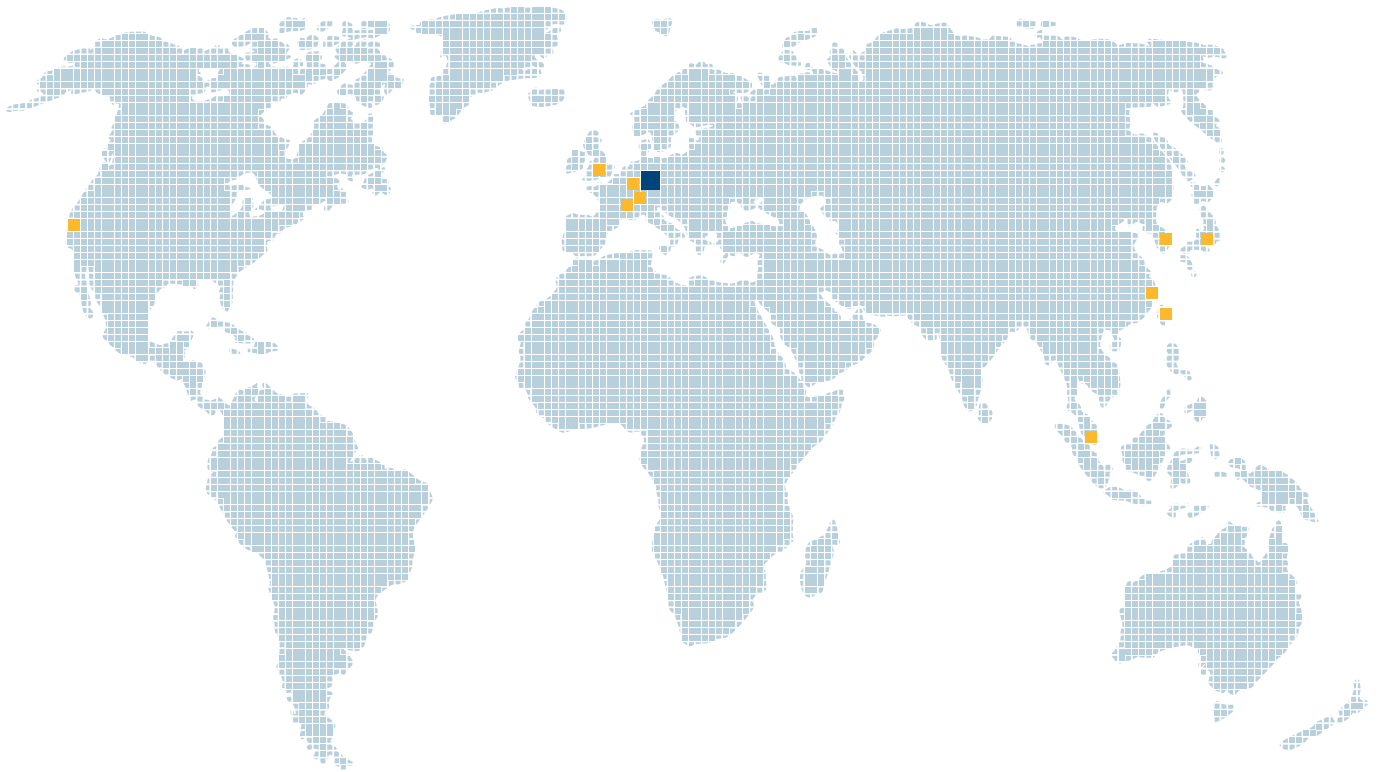

■ Headquarters ■ Sites



Visit www.suss.com/locations
for your nearest SUSS representative or
contact us:
SÜSS MicroTec SE
+49 89 32007-0 · info@suss.com

WWW.SUSS.COM

