

Structural Bonding

Requirements, Adhesives
and Applications

Bonded cogwheels on a gear shaft

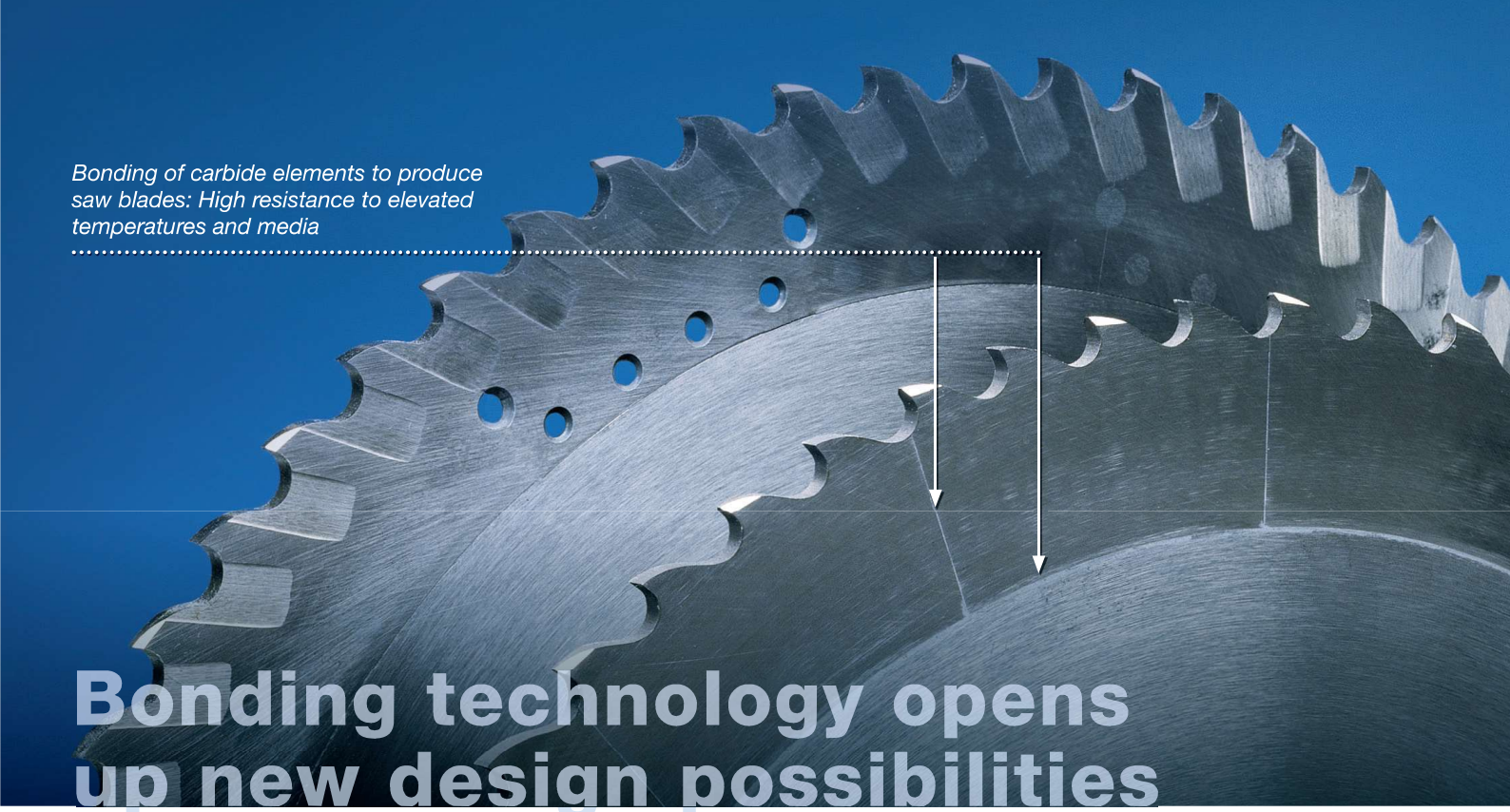

Bonding of carbide elements to produce saw blades: High resistance to elevated temperatures and media

Bonding technology opens up new design possibilities

Adhesives have become an essential assembly element in industrial production, and perform a multitude of functions. Comparable performance can be achieved with no other joining technique. Numerous tests have proven the superiority of adhesives over screws, rivets and welds.

In addition, a great deal of weight and therefore energy can be saved by using adhesives. Therefore, bonding technology is now used in fields where adhesives would have been unimaginable only a few years ago, such as in

mechanical engineering and even heavy-duty structures with high mechanical loads.

Satisfied customers:

ABM Greiffenberger Antriebstechnik GmbH, CLAAS Industrietechnik GmbH, Demag Cranes & Components GmbH, DLR Deutsches Zentrum für Luft- und Raumfahrt e.V., Grundfos Pumpenfabrik GmbH, hansgrohe AG, KTR Kupplungstechnik GmbH, Leistritz Hydraulik GmbH, Maschinenfabrik Mönninghoff GmbH & Co. KG, PREH GmbH, Voith Turbo GmbH & Co. KG, and many more...



Selection Charts
 “DELO-ML”
 “DELO-DUOPOX, DELO-PUR”
 “DELO MONOPOX,
 DELO DUALBOND”

DELO's adhesives for structural bonding...

... are ideal for many applications and requirements:



DELO-ML

- For metal bonding and metal/mixed joints
- Some products are light- or UV-curing
- Easy, one-component processing
- Fast initial strength within a few minutes (anaerobic curing) or seconds (UV/light fixation)
- Good resistance to media and elevated temperatures
- Tension-equalizing, flexible, impact resistant variants



DELO-DUOPOX

- Especially for very large or temperature-sensitive components
- Easy, “one-component” processing in the side-by-side cartridge system
- High media resistance
- Good mechanical properties
- For bonding components with high strength requirements



DELO MONOPOX

- For high-strength bonding
- High resistance to media and elevated temperatures
- Excellent mechanical properties
- Wide temperature range of use -55 to +220 °C
- Often used as a replacement for conventional joining methods like riveting, welding or hard soldering
- Easy, one-component processing



DELO-PUR

- Easy, “one-component” processing in the side-by-side cartridge system
- For bonding metal and plastic
- For peel-resistant and tension-equalizing bonding
- Very high strength
- Well suited for large bonding gaps



All products are solvent-free and compliant with the RoHS Directive 2015/863/EU.



Many products are halogen-free acc. to or by the criteria of IEC 61249-2-21. Details can be found in the Technical Data Sheet.

Adhesive-friendly design of bonded connections

In order to be able to fully exploit the advantages of adhesives, the design of the joint must match bonding technology. Proper design of the components for bonding can

- Prevent costs,
- Speed production processes, and
- Expand the range of suitable adhesives.

Adhesive-friendly design means:

- Provision of sufficiently large bonding surfaces
- Even distribution of tensions
- Only compression, tensile and shear stress if possible
- Avoiding peel and bending stress
- Avoiding eccentric force transmission
- Avoiding plastic component deformation

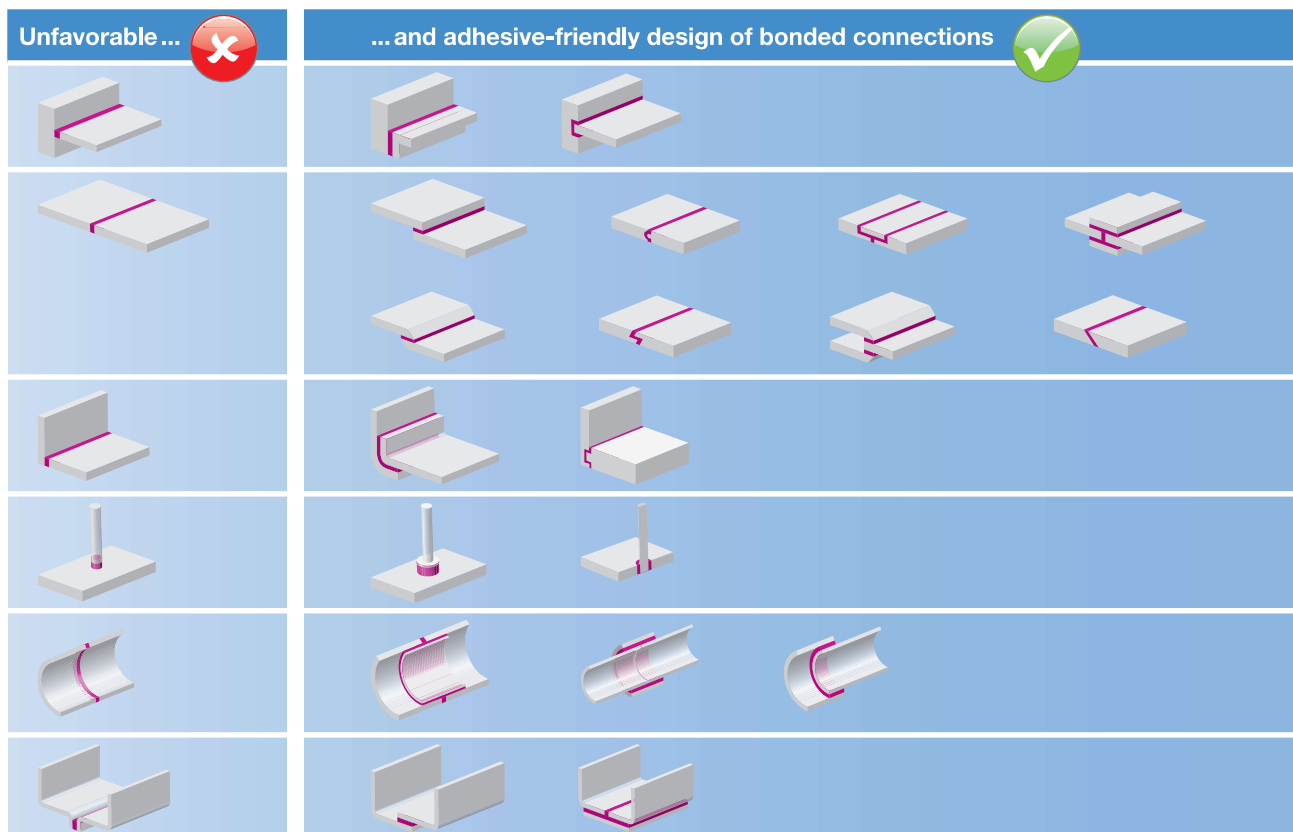

Surface pretreatment

DELO-SACO blasting technique

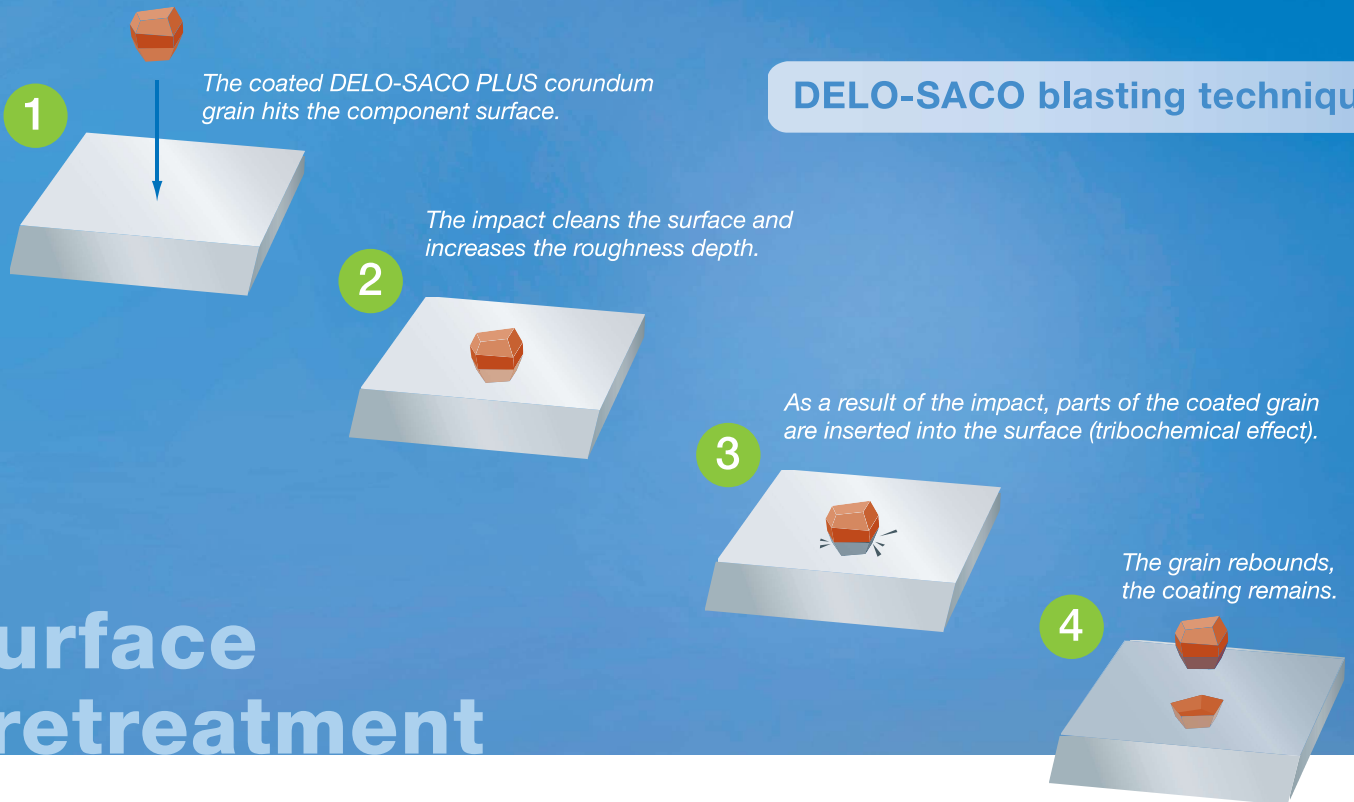

It is not only essential to choose the right adhesive. The finish of the component surface is also of great importance for the achievable bond strength, and even more so for the durability of the bond. In general, the surfaces to be bonded are to be dry, as well as free of dust, grease and other contaminations.

The objective of surface pretreatment is to create even and defined surfaces as the basis for

- Even and proper wetting of the component surface with adhesive
- Improved adhesion
- A reproducible, permanently strong connection

DELO-SACO sand blasting

SACO = Simultaneous abrasion (**S**And blasting) and **C**Oating of the surface (see figure above).

- For use on metal, plastic and ceramic
- For preparing difficult to bond materials
- Enables excellent bond strength and aging resistance

DELOTHEN cleaning agents

For degreasing the surface and the removal of contaminants. DELOTHEN cleaning agent e.g. is sprayed directly onto the surface to be cleaned from a

distance of 20 – 30 cm. After thorough cleaning with a lint-free cloth, the adhesive can then be applied.



The “BOND it – Reference Book on Bonding Technology” provides a comprehensive overview of pretreatment methods.



High structural strength at storage and retrieval machines

Bonded storage and retrieval machine in high-bay warehouse

Light-weight construction

Light-weight hybrid construction is highly valued in mechanical engineering applications, such as the storage and retrieval machine shown.

This increases acceleration, boosts stock rotation and saves energy.

The **framework** made of aluminum or steel (corner connectors) and fiber composite material (channel bars) are **bonded**.

Advantages over other joining methods:

- Natural low weight of adhesives
- Laminar force transmission enables thinner structures

High requirements

Outstanding strength and reliability of the bond are essential in this application.

Therefore, **DELO-DUOPOX AD848** is used: This 2C epoxy resin excels with its high structural strength and good damping behavior.

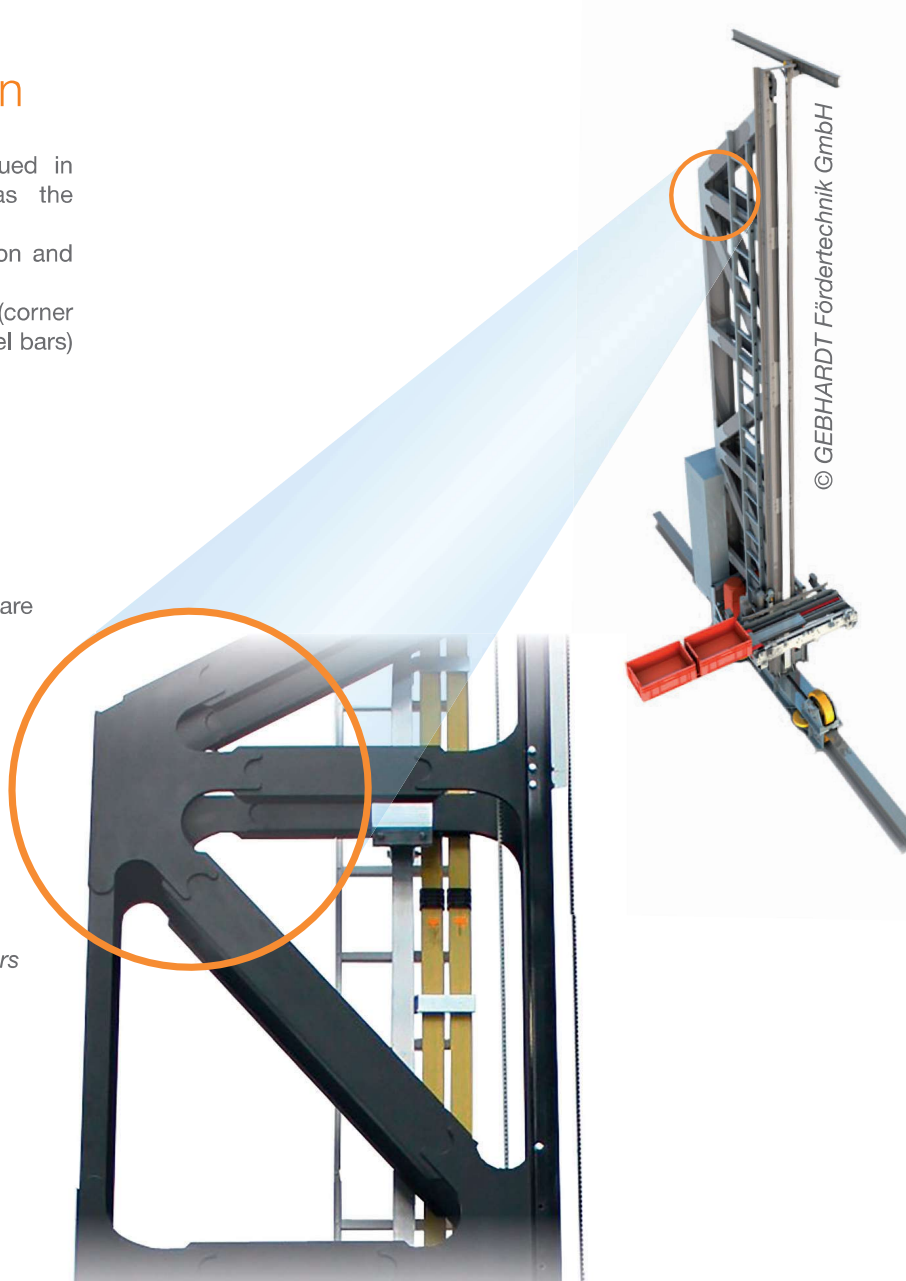

© GEBHARDT Fördertechnik GmbH

Bonding corner connectors



Unmounted pressure gauges
from FT Manovia

Short cycle times for fire extinguisher pressure gauges

New materials require new joining methods

Many fire extinguishers are equipped with pressure gauges, allowing users to check at any time whether the pressure in the container is still in the “green zone”. A crucial factor here is to **connect the spiral element to the brass housing**.

Since recent fire extinguishing agents aggressively attack the spiral elements that used to be made of copper and bronze, stainless steel is now being used. However, this made soft soldering an unsuitable method for joining spiral element and brass housing. That is why bonding is the ideal choice to ensure a fast and versatile process.

High requirements

FT Manovia relies on the **DELO MONOPOX AD295** construction adhesive. Thanks to its good resistance to aggressive media, it is often used in applications where reliability as well as strength are important.

Furthermore, it is well suited for induction curing: The adhesive reaches full strength after just 5 s and the pressure gauge can be further processed – given the quantity of 5 million pieces produced annually, this is indeed an important feature.



Bonding is the ideal method for joining
spiral element and brass housing



Lighter and more comfortable wheelchairs

Multi-material design

Lightweight wheelchairs provide for independence, mobility, and flexibility in everyday life. With a weight of just 21 kg, the active wheelchair LEVO Summit EL is the lightest wheelchair with electric stand-up function available on the market, and particularly impresses with its excellent stability for a secure upright position.

This low weight can also be attributed to bonding: No other technique is so well suited for joining different lightweight materials. In the case of the LEVO wheelchair, not only the **carbon and aluminum parts of the wheel axle are joined by bonding**, but also **steel and aluminum components of the frame**.

High requirements

The **DELO-DUOPOX** adhesive used here not only reaches the required strengths, but can also be applied in nearly any layer thickness and is thus well suited as a construction element.

In addition, the adhesive's flow resistance makes it easy to manually join the components.

The **DELO-XPRESS** dispensing gun allows for simple and fast manual processing of the two-component product.

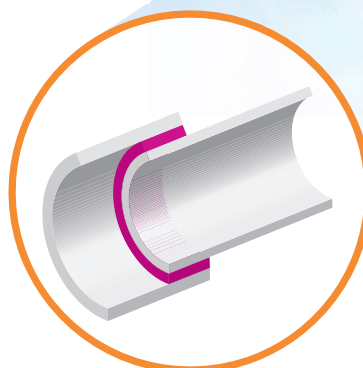

Lightweight stand-up wheelchair with bonded rods
© LEVO AG



ISS International Space Station
with ROKVISS (© NASA)

Rotor: DELO MONOPOX bonds
the magnets to the stator
(© DLR)



Adhesives in space

Epoxy resin keeps motors together

DELO adhesives are used in space – in the aerospace project ROKVISS (Robotic Components Verification on ISS).

ROKVISS consists of a robotic manipulator with two hinges, a camera that follows the movements of the robotic manipulator and another camera that observes Earth.

So that the robotic manipulator can move flexibly, it is equipped with two hinges driven by motors. DELO developed the epoxy adhesive that holds these motors together. Not only are the **magnets bonded to the stator**, but the **stator is also bonded into the motor housing**. The adhesive fulfills the requirements of space use, and is now used in all motors manufactured by the DLR (Deutsches Zentrum für Luft- und Raumfahrt = German Aerospace Center). In addition, this adhesive family is also used for other applications such as in car engine compartments.

High requirements

The one-component, heat-curing **DELO MONOPOX AD295** epoxy resin is used. The adhesive is ideal for bonding metals, temperature-resistant plastics, ferrites and ceramics.

It is particularly suitable for high-strength, tough-hard connections with high resistance to static and dynamic stress, even at elevated temperatures. It meets the requirements of the ECSS Q-70-02 thermal vacuum outgassing test used to screen space materials.

DELO's adhesives in action

Securing screws in differential gears

Methacrylate  2-4 min  0.3 Pas viscosity

DELO-ML 5327

- High-strength connection
- Excellent media resistance
- Normal temperature range from -60 °C to +200 °C
- Accelerated curing in combination with DELO-QUICK enables short cycle times
- For high force transfer

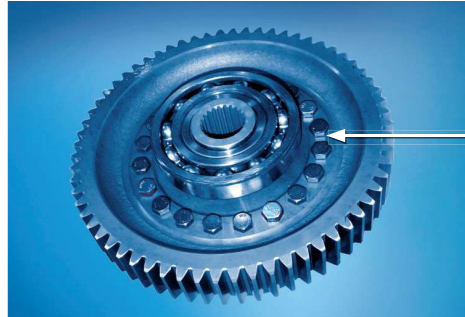

Bonding and securing of screws in the differential gear of a combine harvester

Bonding steel stator to housing

Methacrylate   1.2 Pas viscosity

DELO-ML DB135

- Very high impact resistance
- Excellent media resistance (for example, to oil, gasoline, diesel)
- Normal temperature range up to +180 °C
- Tension-equalizing: High-strength bonding of metals with dissimilar coefficients of expansion
- Prompt functional strength with the help of light fixation; anaerobic curing of adhesive in shadowed areas



Bonding of stator laminations to an aluminum housing (© ebm-papst)

Bonding collector socket to shaft

1C epoxy  40 min @ 150 °C  110 Pas viscosity

DELO MONOPOX HT2860

- High-strength, tough-hard connection
- Excellent media resistance (for example, to transmission oil or ethanol)
- Normal temperature range up to +220 °C
- Very high static and dynamic loading capacity
- High dielectric strength

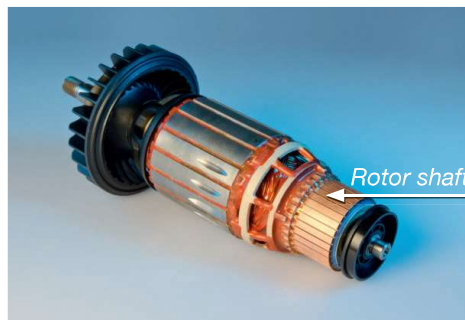

Bonding of a collector socket to a shaft of an electric motor, e.g. for angle grinders (component: metabo)

Bonding magnesium half shells

1C epoxy  40 min @ 150 °C  pasty viscosity

DELO MONOPOX SJ2981

- High-strength connection
- Good media resistance
- High temperature resistance and stability
- Vibration-resistant
- High-viscous, run-resistant

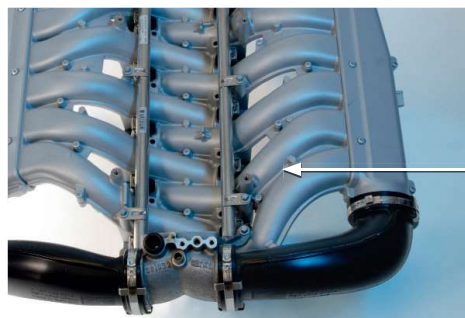

High-strength bonding of top shell, bottom shell, and side panels of intake manifold modules for engines

Attaching banister elements

2C epoxy 5.5 h initial strength 90 Pas viscosity

DELO-DUOPOX AD895

- Fills gaps, suitable for small and large bonding gaps
- Good media resistance and aging resistance
- For interior and exterior use
- Efficiency: Flexible modular system in banister construction. The additional process steps required for welding, such as grinding or polishing, are avoided.



Bonding of banister elements for interior and exterior use



Bonding bearings

2C epoxy 7 h initial strength 80 Pas viscosity

DELO-DUOPOX AD840

- High bond strength and temperature resistance
- Good media resistance
- Design advantages over screwed joints, mechanical advantages due to the laminar bond

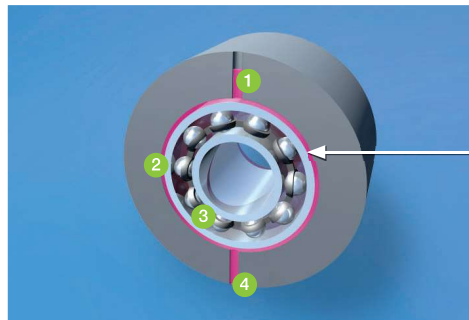

Bonding a bearing into a plastic housing (adhesive colored magenta)

- 1 Adhesive feed
- 2 Circumferential bonding gap
- 3 Ball bearing
- 4 Vent borehole

Sealing housings

2C polyurethane 90 min initial strength 90 Pas viscosity

DELO-PUR 9691

- Good tough-elastic properties
- Good media resistance
- Excellent equalization of tensions
- Fast initial strength
- Successfully tested by the criteria of UL 94 HB



Reliable and tension-equalizing sealing of an electronic housing against media infiltration

Installing fixtures in ships

2C polyurethane 5.5 h initial strength pasty viscosity

DELO-PUR 9694

- Run-resistant → Highly suitable for larger bonding gaps and bonding on vertical areas
- Good tough-elastic properties
- High strength even under static and dynamic stress
- High resistance to sea-water
- Excellent equalization of tensions



Bonding of retainers and angles with disparate geometries to interior bulkheads



CONTACT

DELO Industrial Adhesives
Headquarters

▶ **Germany** · Windach / Munich



- ▶ **China** · Shanghai
- ▶ **Japan** · Yokohama
- ▶ **Malaysia** · Kuala Lumpur
- ▶ **Singapore**
- ▶ **South Korea** · Seoul
- ▶ **Taiwan** · Taipei
- ▶ **Thailand** · Bangkok
- ▶ **USA** · Sudbury, MA

..... www.DELO-adhesives.com

The data and information provided are based on tests performed under laboratory conditions. Reliable information about the behavior of the product under practical conditions and its suitability for a specific purpose cannot be concluded from this. It is the customer's responsibility to test the suitability of a product for the intended purpose by considering all specific requirements and by applying standards the customer deems suitable (e. g. DIN 2304-1). Type, physical and chemical properties of the materials to be processed with the product, as well as all actual influences occurring during transport, storage, processing and use, may cause deviations in the behavior of the product compared to its behavior under laboratory conditions. All data provided are typical average values or uniquely determined parameters measured under laboratory conditions. The data and information provided are therefore no guarantee for specific product properties or the suitability of the product for a specific purpose. Nothing contained herein shall be construed to indicate the non-existence of any relevant patents or to constitute a permission, encouragement or recommendation to practice any development covered by any patents, without permission of the owner of this patent. All products provided by DELO are subject to DELO's General Terms of Business. Verbal ancillary agreements are deemed not to exist.

© DELO – This brochure including any and all parts is protected by copyright. Any use not expressly permitted by the Urheberrechtsgesetz (German Copyright Act) shall require DELO's written consent. This shall apply without limitation to reproductions, duplications, disseminations, adaptations, translations and microfilms as well as to the recording, processing, duplication and/or dissemination by electronic means. 05/19

ADHESIVES

DISPENSING

CURING

CONSULTING

DELO