

In-Circuit Emulator for Renesas H8/300 and H8/500

H8/3001	H8/3217	H8/3640
H8/3002	H8/322	H8/3641
H8/3003	H8/323	H8/3642
H8/3004	H8/324	H8/3643
H8/3005	H8/325	H8/3644
H8/3006	H8/3256	H8/3812
H8/3007	H8/3257	H8/3813
H8/3030	H8/326	H8/3833
H8/3031	H8/327	H8/3834
H8/3032	H8/328	H8/3835
H8/3040	H8/329	H8/3836
H8/3041	H8/3292	H8/3837
H8/3042	H8/3294	H8/520
H8/3044	H8/3296	H8/532
H8/3045	H8/3297	H8/534R
H8/3047	H8/330	H8/534S
H8/3048	H8/3334Y	H8/536R
H8/3048F	H8/3334YF	H8/536S
H8/3060	H8/3336Y	H8/537
H8/3061	H8/3337Y	
H8/3062	H8/336	
H8/3064	H8/337	
H8/3065	H8/338	
H8/3066	H8/3394	
H8/3067	H8/3396	
H8/3101	H8/3397	
H8/3102	H8/3434	
H8/3202	H8/3434F	
H8/3212	H8/3436	
H8/3214	H8/3437	
H8/3216	H8/350	

- Support for 300, 300H and 500 family
- Support for 5V and 3.3V
- Full bondout support
- Up to 20MHz support
- On chip ROM and FLASH emulation
- Banking up to 16MByte (256 banks)
- Dual ported memory
- Software compatible ROM Monitor
- Interface with all compilers
- RTOS support
- CASE tool interface
- Windows9x, NT and X windows interface

TRACE32-ICEH8 supports most members of the H8 family from Renesas. The modular and open technology of the system allows the fast integration of new chip designs.

TRACE32-ICE is a state of the art In-Circuit Emulator, which offers unlimited hardware breakpoints and up to 16MByte dual-ported emulation memory. The real-time trace and trigger work up to the max. speed of the CPU. The analyzer offers selective trace

as well as performance analysis and statistic functions.

The system offers an interface to all C and C++ compilers. Full RTOS support is available for HIOS/Renesas and Nucleus PLUS from Accelerated Technology.

TRACE32 works with the highest variety of host interfaces. The communication link to the host is done by the printer port, a fibre optic interface or ethernet allowing a high speed transfer.

Features

Basics of Operation

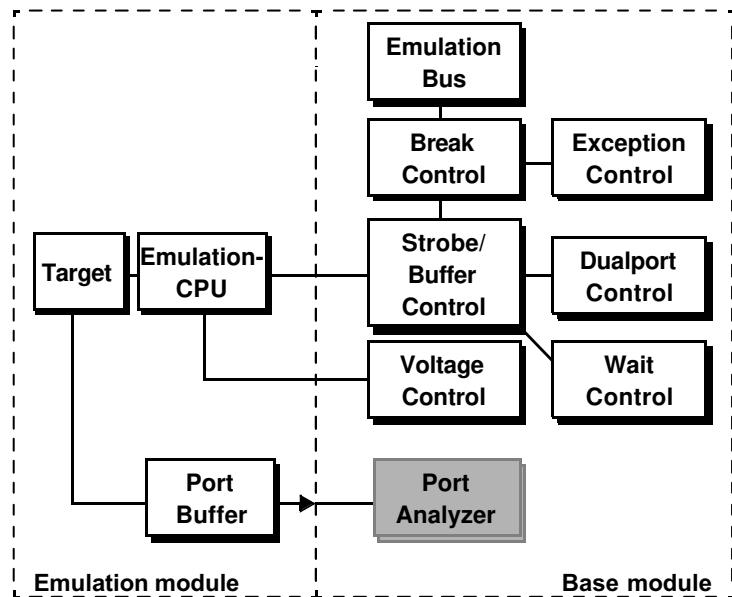

The ICE H8 probe is a high-performance emulation system for many derivatives of the H8 family. The change between different CPU types is done by changing the emulation module.

On the emulation base there is an extra slot for the TRACE32 Port Analyzer which can trace up to 64 port lines.

Operating Modes

The Emulator can work in stand-alone mode with internal clock or in active mode with internal or the target clock. On power-down of the target system the emulator tristates its output buffers and isolates its internal emulation circuits.

The operation modes are as follows:

- Reset Down
- Reset Up
- No Probe
- Alone Internal
- Alone External
- Emulation Internal
- Emulation External

Clock

- Operation with external or internal clock

- Max. operation frequency:
20 MHz

Clock Fail Detection

Support for all Operation Modes

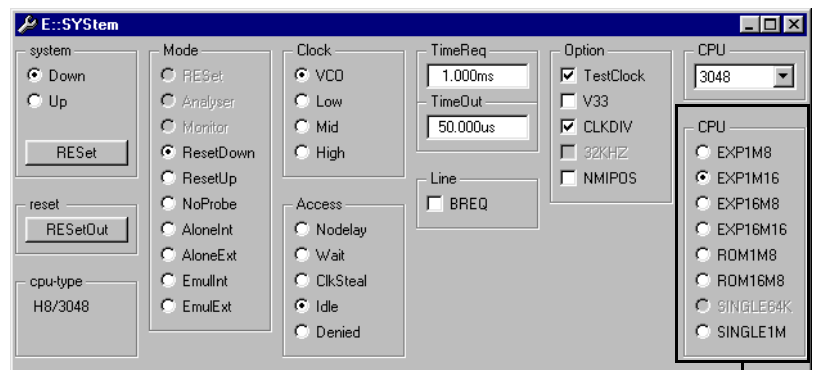

Operation modes

ICE-H8 supports the realtime emulation of all operations modes at max. speed.

Dual-port Access

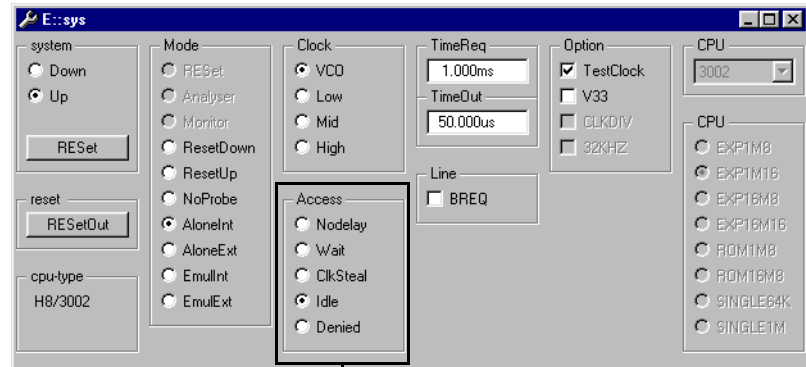

Dual port access modes

All TRACE32 memories are dual-ported. The dual-port access makes it possible to display and modify the contents of the overlay memory, to set or delete breakpoints or use the flag memory while the application is running in real-time.

The H8 has four dual-port modes:

- Nodelay
- Wait
- ClkSteal
- Idle

In **Nodelay** mode, the dual-port access is inserted in the regular bus cycles, generated by the CPU. This means that the CPU runs in real time during the dual-port access.

In **Wait** mode, wait states are inserted for the dual-port access via the wait pin. This is only possible, if the corresponding pins is configured as the wait pin.

In **ClkSteal** mode, the CPU clock is stopped for some cycles during the dual-port access. This works only if the emulator uses the internal VCO clock.

In **Idle** mode, the emulator waits on idle cycles of the CPU to perform the dual-port access. This cycles are generated for example during subroutine jumps.

In the **Denied Mode** the dual-port access is switched off.

Peripheral Information

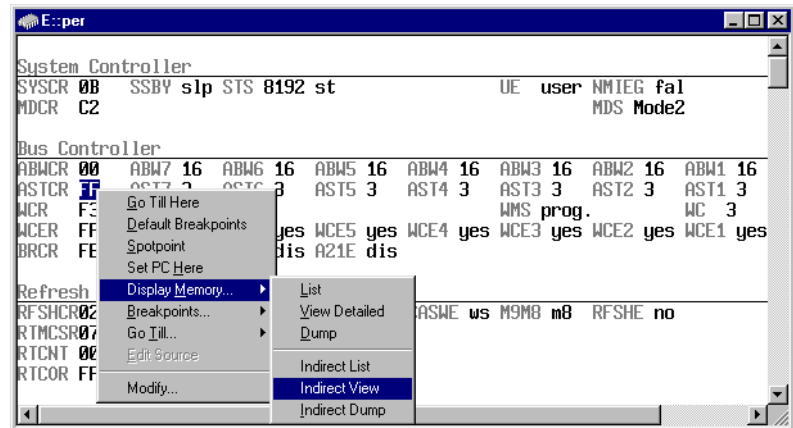

- Display of onchip peripherals
- User definable display of the onchip peripherals
- Definition is done interactive supported by softkeys
- Pull down menus for settings
- Additional description for each field
-

Exception Control

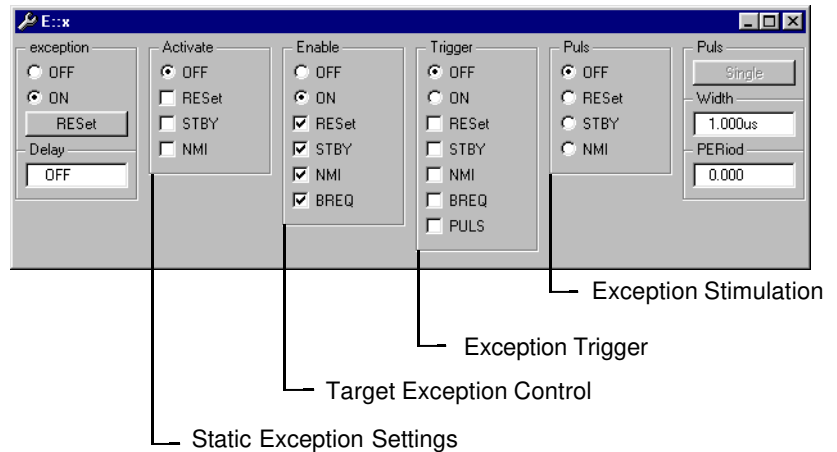

The TRACE32 exception controller allows to permanently activate an exception, to enable or disable specific

exceptions, to trigger on specific exceptions or to stimulate an exception.

HLL Debugging

The screenshot shows the TRACE32 debugger window with the following assembly code and a context menu open over the instruction at address 01238A:

Step	Step Over	Go Next	Go Return	Go Up	Go	Break	Mode
addr/line	code	label	mnemonic	comment			
P:012374	1AE6		sub.l	er6,er6			
P:012376	01006FF6000C		mov.l	er6,@(0C,sp)	; er6,@(anzahl,sp)		
690					for (i = 0 ; i <= SIZE ; flags[i++] = TRUE) ;		
P:01237C	010069F6		mov.l	er6,@sp			
P:012380	01006976		mov.l	@sp,er6			
P:012384	7A2600000012		cmp.l	#12,er6	; #18,er6		
P:01238A	4E14		bgt				
P:01238C	0B76		inc.				
P:01238E	010069F6		mov.				
P:012392	1B76		dec.				
P:012394	FD01		mov.		; #1,r51		
P:012396	78606AAD00040E...		mov.		; r51,@(flags,er6)		
P:01239E	40E0		bra				
692					for (i = 0 ; i <= SIZ		
P:0123A0	1AE6		sub.				
P:0123A2	010069F6		mov.				
P:0123A6	01006976		mov.				
P:0123AA	7A2600000012		cmp.		; #18,er6		

The context menu for the instruction at address 01238A includes the following options:

- Go Till Here
- Default Breakpoints
- Spotpoint
- Set PC Here
- Display Memory...
- Breakpoints...
- Go Till...
- Edit Source
- List There
- Assemble here ...
- Modify here ...

Full support in real-time for:

- Break-before-line operation
- HLL single step in real-time

- Trigger and trace on local variables

Background Task

The background task allows:

- To process interrupts

- To maintain the refresh of a target DRAM while the emulation is stopped.

Peripheral Window

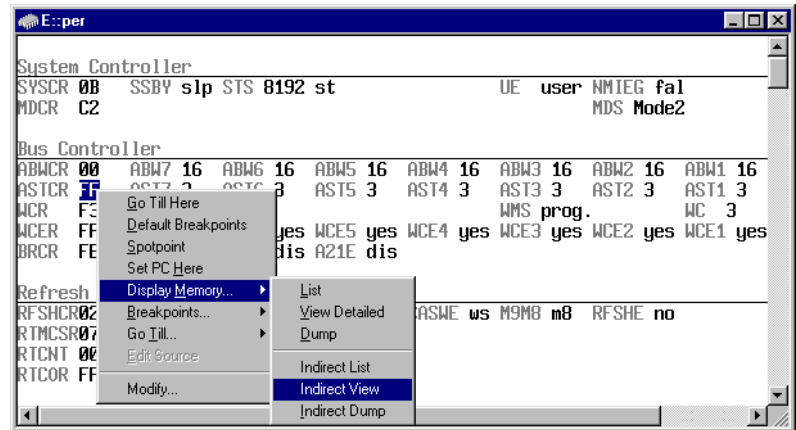

- Display of onchip peripherals
- User definable display of the onchip peripherals
- Definition is done interactive supported by softkeys
- Pull down menus for settings
- Additional description for each field
-

Memory Banking (H8/300 only)

ICE-H8 supports up to 256 banks for internal or external banking:

- Support for paged EPROMS
- Support for external banking using a CPU register or a CPU output pin. For external banking a separate banking probe is needed.

Emulation Modules

Modules Overview

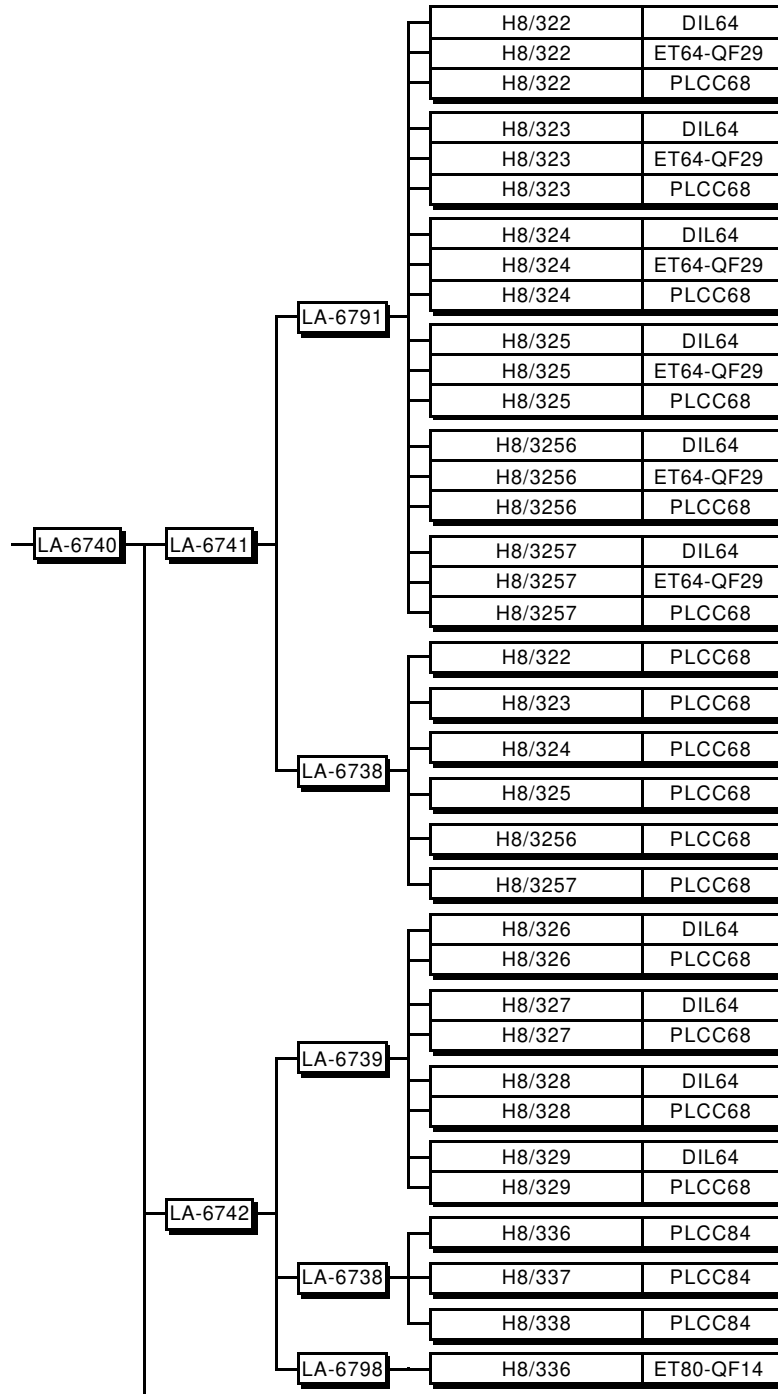

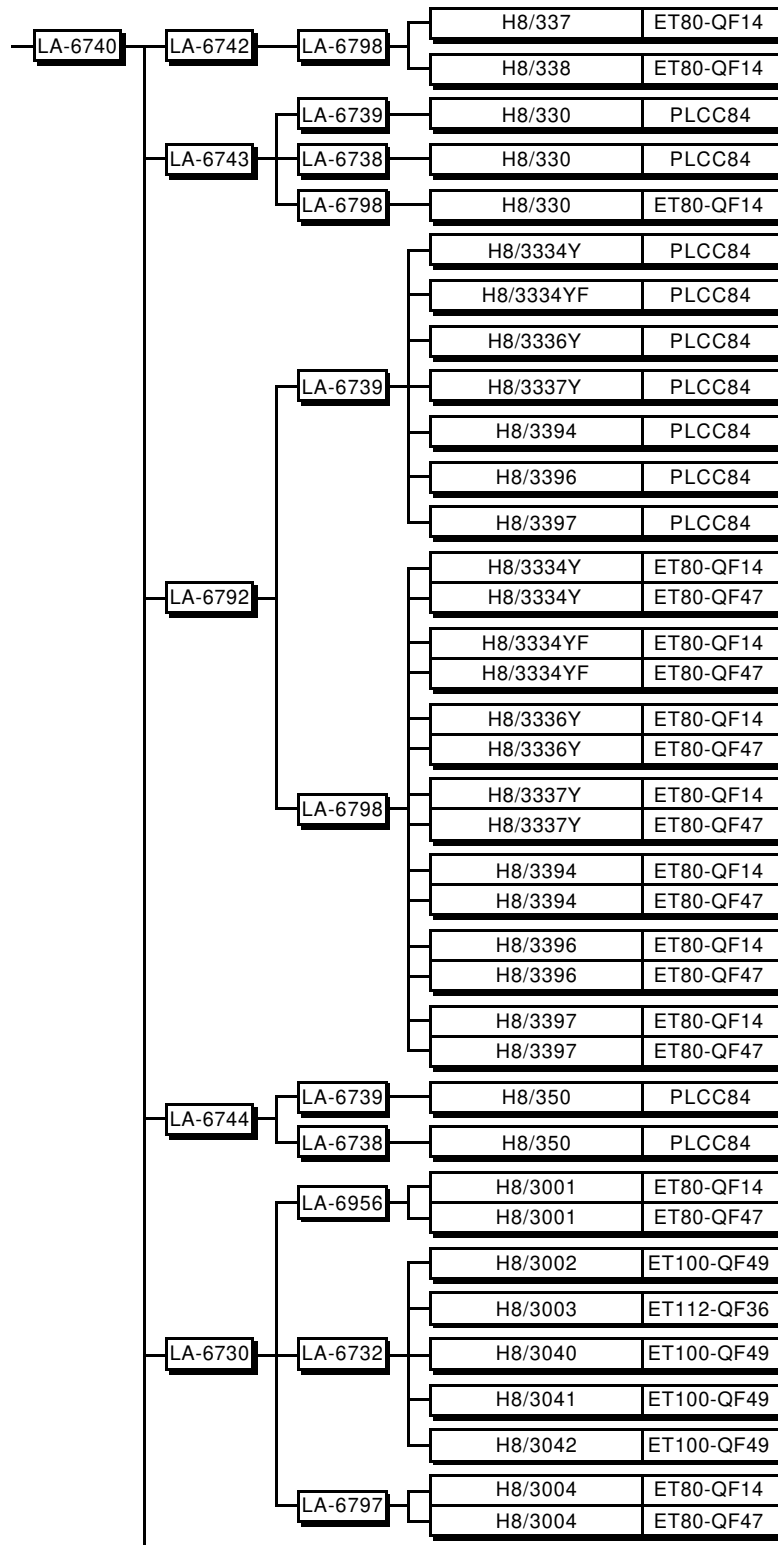

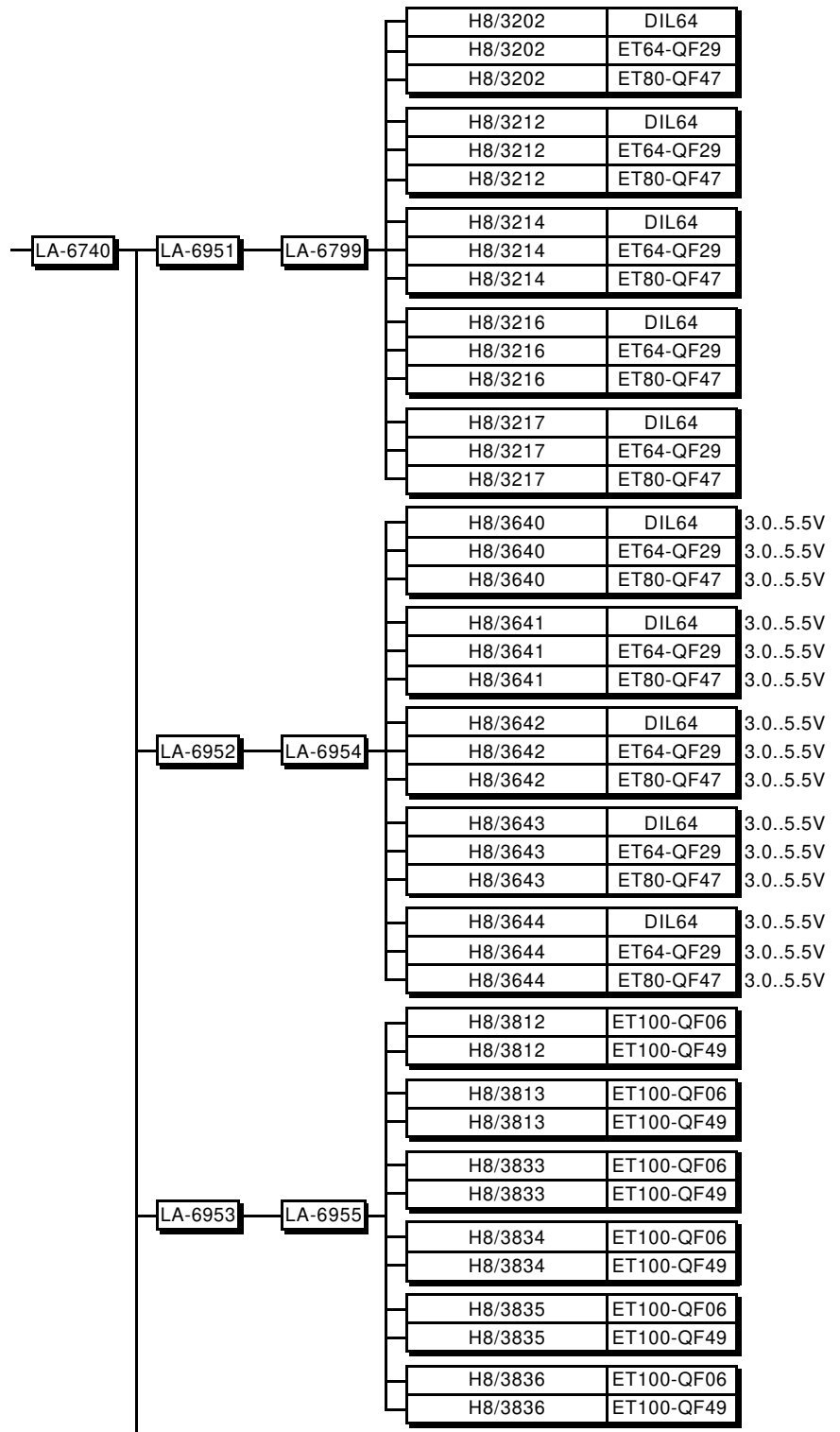

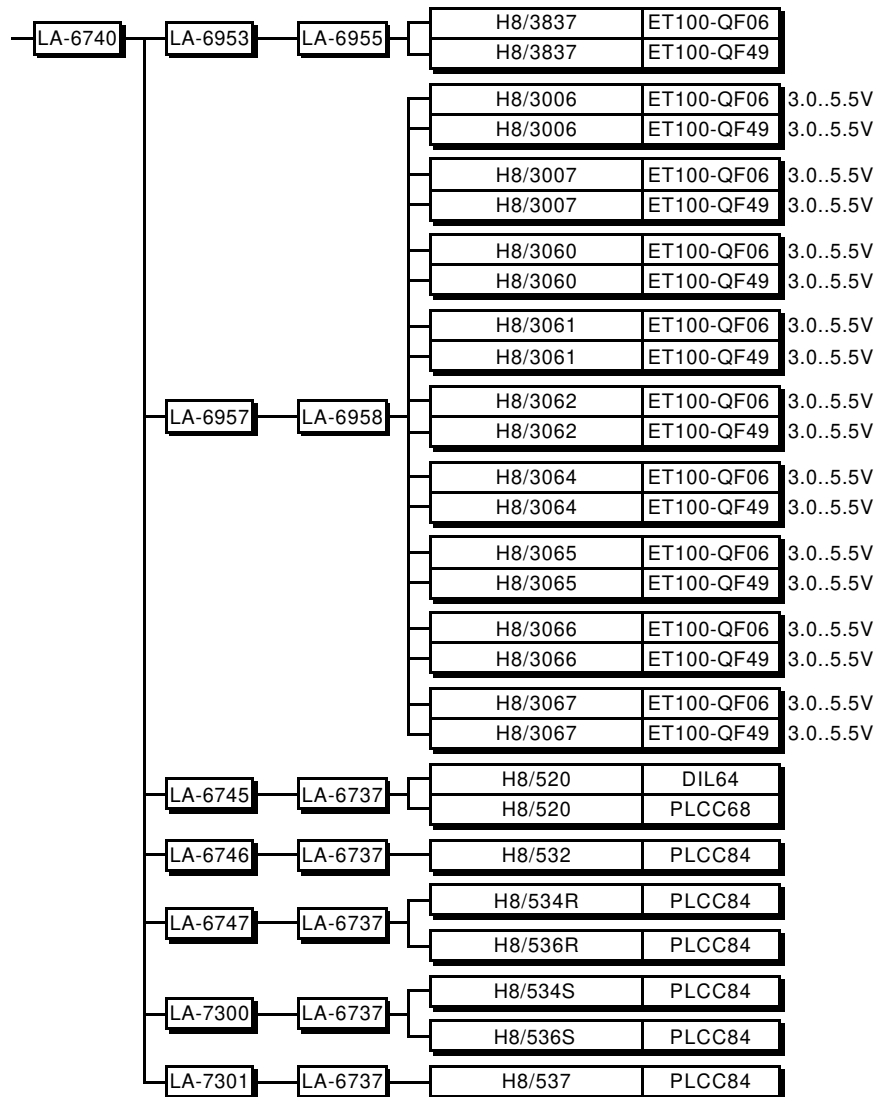

Debug Interfaces

TRACE32-PowerView supports most compilers, realtime operation systems and debuggers.

New integrations are mostly done on customers request. If your compiler or RTOS is not supported now, please ask us !

Compiler H8300

Language	Compiler	Company	Option	Comment
C	GNU-C	FSF	COFF	H8/300
C	ICCH8300	IAR	UBROF	H8/300
C	MCCH83	Mentor Graphics	IEEE	H8/300
C	CH38	Renesas	SYSROF	H8/300
C++	GNU-C++	FSF	COFF	H8/300

Compiler H8/300H

Language	Compiler	Company	Option	Comment
C	GNU-C	FSF	COFF	H8/300H
C	IARH8	IAR	UBROF	H8/300H
C	CH38	Renesas	SYSROF	H8/300H
C++	GNU-C++	FSF	COFF	H8/300H

Compiler H8500

Language	Compiler	Company	Option	Comment
C	ICCH8500	IAR	UBROF	H8/500
C	MCCH85	Mentor Graphics	IEEE	H8/500
C	HICROSS-H8/500	Metrowerks	HICROSS	H8/500

RTOS Support

Name	Company	Comment
OSEK	-	via ORTI
ProOSEK	3Soft	via ORTI
CMX-RTX	CMX Company	
HIOS	Renesas	(HI8-3H), not supported in EUR
Nucleus PLUS	Accelerated Tech.	

Debugger Support

CPU	Debugger	Company	Host
ALL	EASYCASE	BKR GmbH	Windows
ALL	X-TOOLS / X32	blue river software	Windows
ALL	ECLIPSE	Eclipse.org	Windows
ALL	ATTOL TOOLS	MicroMax	Windows
ALL	VISUAL BASIC INTERFACE	Microsoft	Windows
ALL	CODEWRIGHT	Premia Corporation	Windows
ALL	DA-C	RistanCASE	Windows
ALL	RHAPSODY IN MICROC	Telelogic	Windows
ALL	WINDOWS CE PLATF. BUILDER	Windows	Windows

Operation Frequency

The maximum operation frequency of TRACE32-ICEH8 depends on:

- The max. frequency of the CPU
- The access time of the overlay memory (15ns or 35ns)
- The mapper mode (**Slow** or **Fast**)
- The number of waitstates (WO = 0 waitstates
W1 = 1 waitstate)
- The dual-port access mode

Idle Access

Module	CPU	F-W0-15	F-W0-35	S-W0-15	S-W0-35	S-W1-15	S-W1-35	DRAM
LA-6730	H8/3001	16.0	12.6	13.3	10.9	16.0+	16.0+	
LA-6730	H8/3002	16.0	12.6	13.3	10.9	16.0+	16.0+	
LA-6730	H8/3003	16.0	12.6	13.3	10.9	16.0+	16.0+	
LA-6730	H8/3004	16.0	12.6	13.3	10.9	16.0+	16.0+	
LA-6730	H8/3005	16.0	12.6	13.3	10.9	16.0+	16.0+	
LA-6957	H8/3006	16.0	12.4	13.1	10.6	16.0+	16.0+	
LA-6957	H8/3007	16.0	12.4	13.1	10.6	16.0+	16.0+	
LA-6731	H8/3030	16.0	12.6	13.3	10.9	16.0+	16.0+	
LA-6731	H8/3031	16.0	12.6	13.3	10.9	16.0+	16.0+	
LA-6731	H8/3032	16.0	12.6	13.3	10.9	16.0+	16.0+	
LA-6730	H8/3040	16.0	12.6	13.3	10.9	16.0+	16.0+	
LA-6730	H8/3041	16.0	12.6	13.3	10.9	16.0+	16.0+	
LA-6730	H8/3042	16.0	12.6	13.3	10.9	16.0+	16.0+	
LA-6731	H8/3044	18.0	13.8	14.7	11.8	18.0+	18.0+	
LA-6731	H8/3045	18.0	13.8	14.7	11.8	18.0+	18.0+	
LA-6731	H8/3047	18.0	13.8	14.7	11.8	18.0+	18.0+	
LA-6731	H8/3048	18.0	13.8	14.7	11.8	18.0+	18.0+	
LA-6731	H8/3048F	18.0	13.8	14.7	11.8	18.0+	18.0+	
LA-6957	H8/3060	16.0	12.4	13.1	10.6	16.0+	16.0+	
LA-6957	H8/3061	16.0	12.4	13.1	10.6	16.0+	16.0+	
LA-6957	H8/3062	16.0	12.4	13.1	10.6	16.0+	16.0+	
LA-6957	H8/3064	16.0	12.4	13.1	10.6	16.0+	16.0+	
LA-6957	H8/3065	16.0	12.4	13.1	10.6	16.0+	16.0+	
LA-6957	H8/3066	16.0	12.4	13.1	10.6	16.0+	16.0+	
LA-6957	H8/3067	16.0	12.4	13.1	10.6	16.0+	16.0+	
LA-6734	H8/3101	5.0+	5.0+	5.0+	5.0+	5.0+	5.0+	
LA-6734	H8/3102	5.0+	5.0+	5.0+	5.0+	5.0+	5.0+	
LA-6951	H8/3202	16.0	12.1	12.9	10.3	16.0+	16.0+	
LA-6951	H8/3212	16.0	12.1	12.9	10.3	16.0+	16.0+	
LA-6951	H8/3214	16.0	12.1	12.9	10.3	16.0+	16.0+	
LA-6951	H8/3216	16.0	12.1	12.9	10.3	16.0+	16.0+	
LA-6951	H8/3217	16.0	12.1	12.9	10.3	16.0+	16.0+	
LA-6741	H8/322	10.0+	10.0+	10.0+	10.0+	10.0+	10.0+	

Module	CPU	F-W0-15	F-W0-35	S-W0-15	S-W0-35	S-W1-15	S-W1-35	DRAM
LA-6741	H8/323	10.0+	10.0+	10.0+	10.0+	10.0+	10.0+	
LA-6741	H8/324	10.0+	10.0+	10.0+	10.0+	10.0+	10.0+	
LA-6741	H8/325	10.0+	10.0+	10.0+	10.0+	10.0+	10.0+	
LA-6741	H8/3256	10.0+	10.0+	10.0+	10.0+	10.0+	10.0+	
LA-6741	H8/3257	10.0+	10.0+	10.0+	10.0+	10.0+	10.0+	
LA-6742	H8/326	10.0+	10.0+	10.0+	10.0+	10.0+	10.0+	
LA-6742	H8/327	10.0+	10.0+	10.0+	10.0+	10.0+	10.0+	
LA-6742	H8/328	10.0+	10.0+	10.0+	10.0+	10.0+	10.0+	
LA-6742	H8/329	10.0+	10.0+	10.0+	10.0+	10.0+	10.0+	
LA-6793	H8/3292	16.0	12.6	13.3	10.9	16.0+	16.0+	
LA-6793	H8/3294	16.0	12.6	13.3	10.9	16.0+	16.0+	
LA-6793	H8/3296	16.0	12.6	13.3	10.9	16.0+	16.0+	
LA-6793	H8/3297	16.0	12.6	13.3	10.9	16.0+	16.0+	
LA-6743	H8/330	10.0+	10.0+	10.0+	10.0+	10.0+	10.0+	
LA-6792	H8/3334Y	16.0	12.1	12.9	10.3	16.0+	16.0+	
LA-6792	H8/3334YF	16.0	12.1	12.9	10.3	16.0+	16.0+	
LA-6792	H8/3336Y	16.0	12.1	12.9	10.3	16.0+	16.0+	
LA-6792	H8/3337Y	16.0	12.1	12.9	10.3	16.0+	16.0+	
LA-6742	H8/336	10.0+	10.0+	10.0+	10.0+	10.0+	10.0+	
LA-6742	H8/337	10.0+	10.0+	10.0+	10.0+	10.0+	10.0+	
LA-6742	H8/338	10.0+	10.0+	10.0+	10.0+	10.0+	10.0+	
LA-6792	H8/3394	16.0	12.1	12.9	10.3	16.0+	16.0+	
LA-6792	H8/3396	16.0	12.1	12.9	10.3	16.0+	16.0+	
LA-6792	H8/3397	16.0	12.1	12.9	10.3	16.0+	16.0+	
LA-6794	H8/3434	16.0	12.1	12.9	10.3	16.0+	16.0+	
LA-6794	H8/3434F	16.0	12.1	12.9	10.3	16.0+	16.0+	
LA-6794	H8/3436	16.0	12.1	12.9	10.3	16.0+	16.0+	
LA-6794	H8/3437	16.0	12.1	12.9	10.3	16.0+	16.0+	
LA-6744	H8/350	10.0	8.6	8.9	7.7	10.0+	10.0+	
LA-6952	H8/3640	16.0	12.1	12.9	10.3	16.0+	16.0+	
LA-6952	H8/3641	16.0	12.1	12.9	10.3	16.0+	16.0+	
LA-6952	H8/3642	16.0	12.1	12.9	10.3	16.0+	16.0+	
LA-6952	H8/3643	16.0	12.1	12.9	10.3	16.0+	16.0+	
LA-6952	H8/3644	16.0	12.1	12.9	10.3	16.0+	16.0+	
LA-6953	H8/3812	5.0+	5.0+	5.0+	5.0+	5.0+	5.0+	
LA-6953	H8/3813	5.0+	5.0+	5.0+	5.0+	5.0+	5.0+	
LA-6953	H8/3833	5.0+	5.0+	5.0+	5.0+	5.0+	5.0+	
LA-6953	H8/3834	5.0+	5.0+	5.0+	5.0+	5.0+	5.0+	
LA-6953	H8/3835	5.0+	5.0+	5.0+	5.0+	5.0+	5.0+	
LA-6953	H8/3836	5.0+	5.0+	5.0+	5.0+	5.0+	5.0+	
LA-6953	H8/3837	5.0+	5.0+	5.0+	5.0+	5.0+	5.0+	
LA-6745	H8/520	10.0+	10.0+	10.0+	10.0+	10.0+	10.0+	
LA-6746	H8/532	10.0+	10.0+	10.0+	10.0+	10.0+	10.0+	
LA-6747	H8/534R	10.0+	10.0+	10.0+	10.0+	10.0+	10.0+	
LA-7300	H8/534S	16.0	12.1	12.9	10.3	16.0+	16.0+	
LA-6747	H8/536R	10.0+	10.0+	10.0+	10.0+	10.0+	10.0+	
LA-7300	H8/536S	16.0	12.1	12.9	10.3	16.0+	16.0+	
LA-7301	H8/537	16.0	12.1	12.9	10.3	16.0+	16.0+	

Dimensions

Module Dimensions

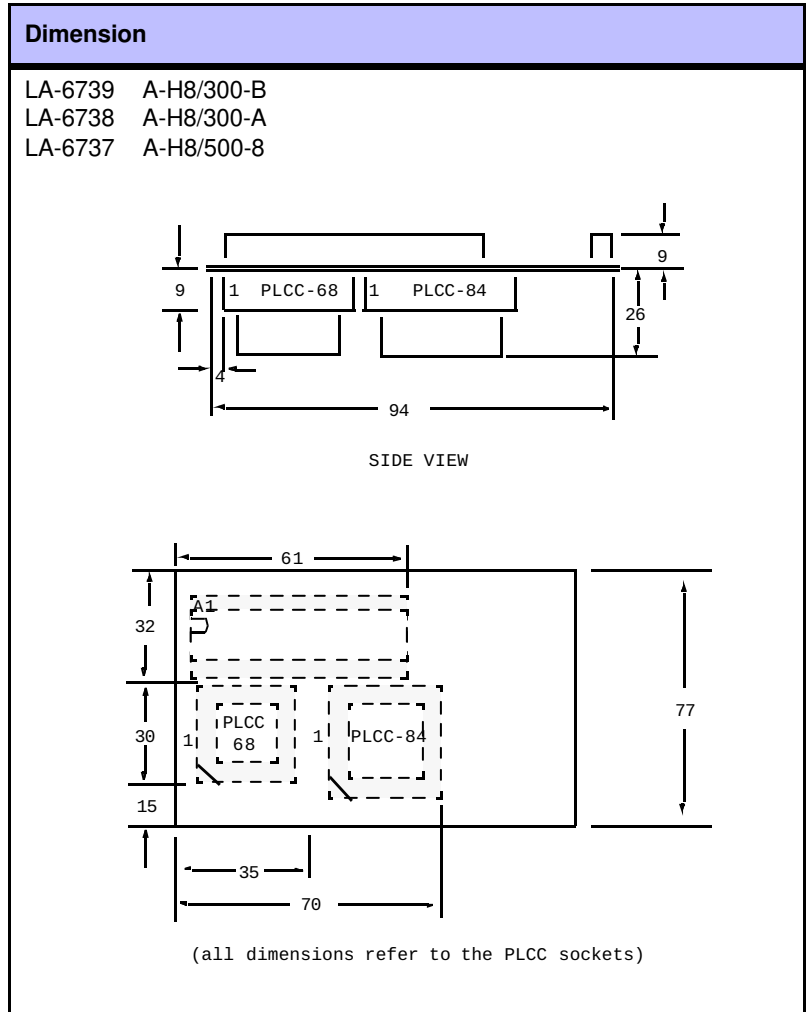

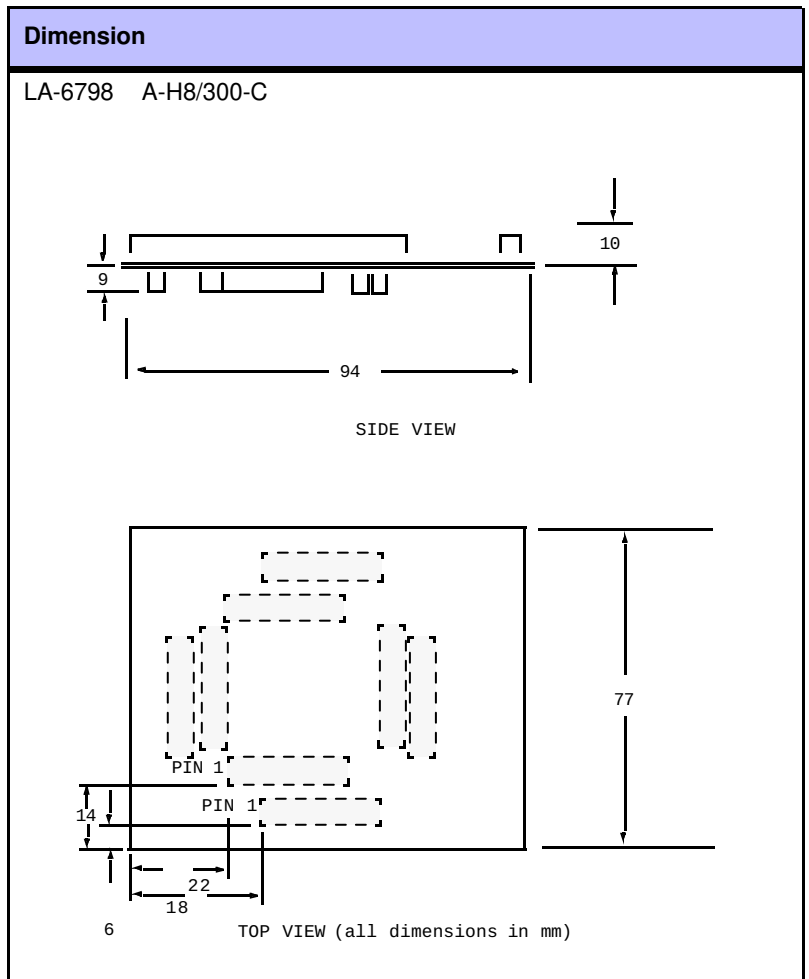

Dimension

LA-6799 A-H8/300-D
LA-6796 A-H8/300-E

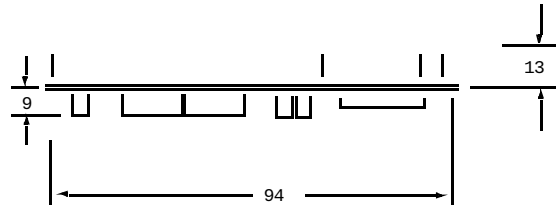

SIDE VIEW

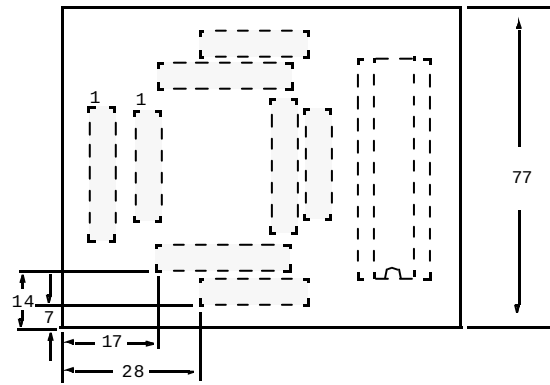

TOP VIEW (all dimensions in mm)

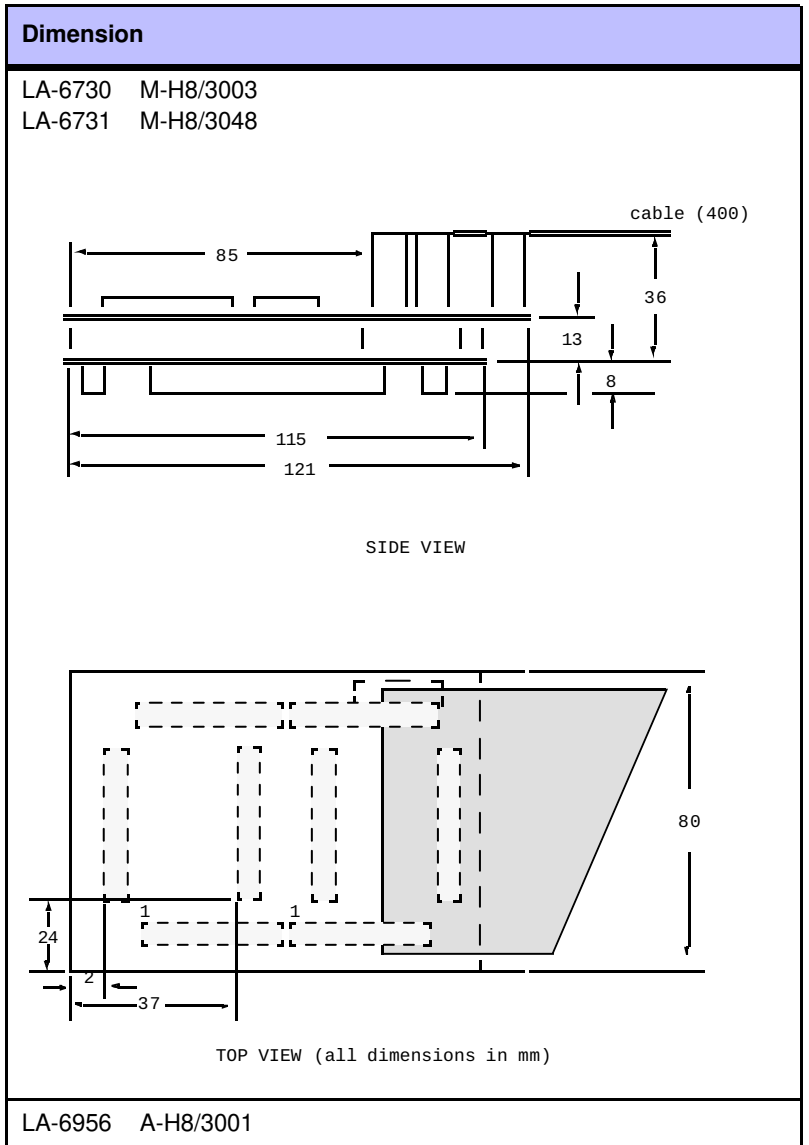

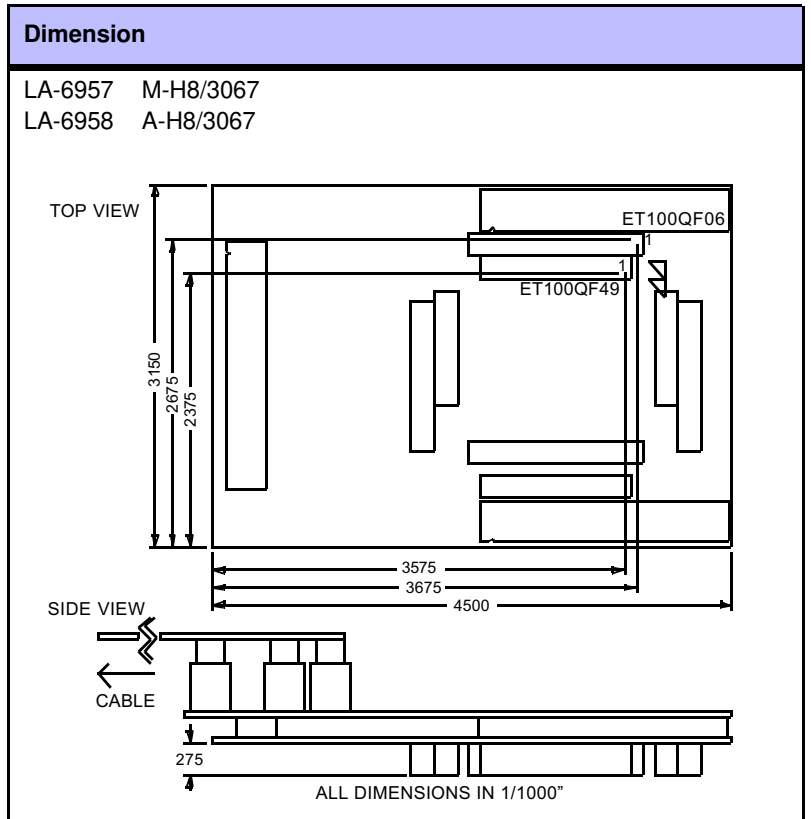

Dimension

LA-6732 A-H8/3003

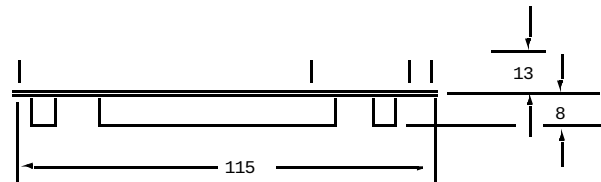

SIDE VIEW

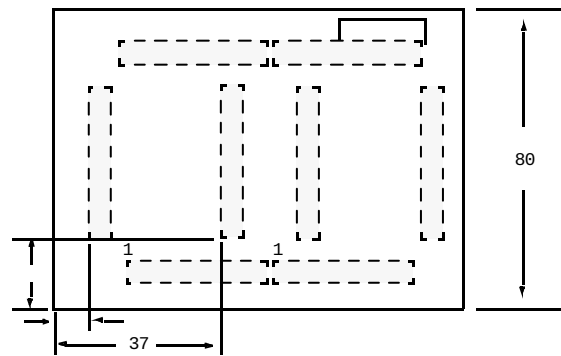

TOP VIEW (all dimensions in mm)

24

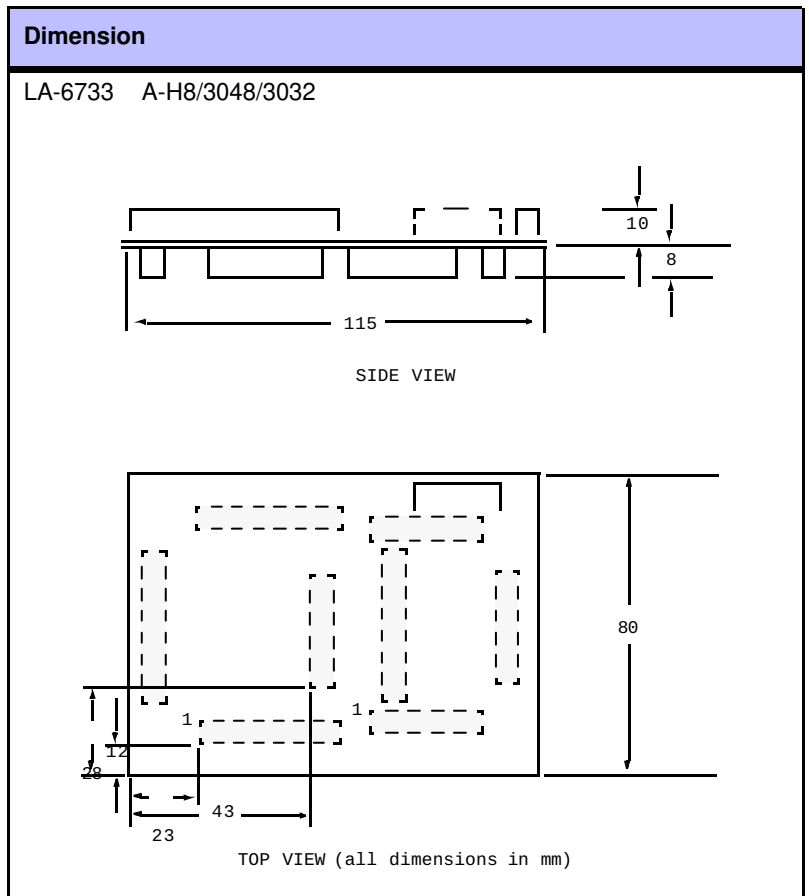

Dimension

LA-6797 A-H8/3004/3005

LA-6735 A-H8/3032

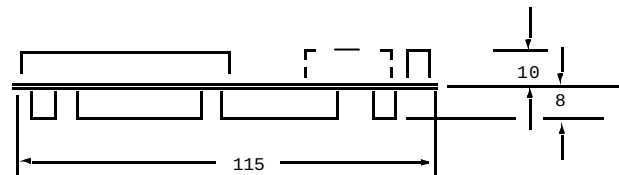

SIDE VIEW

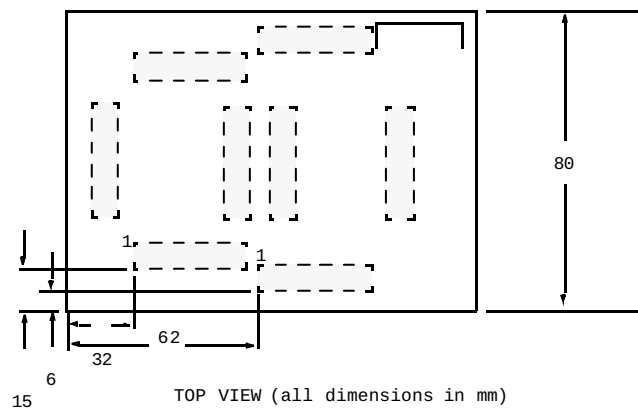

TOP VIEW (all dimensions in mm)

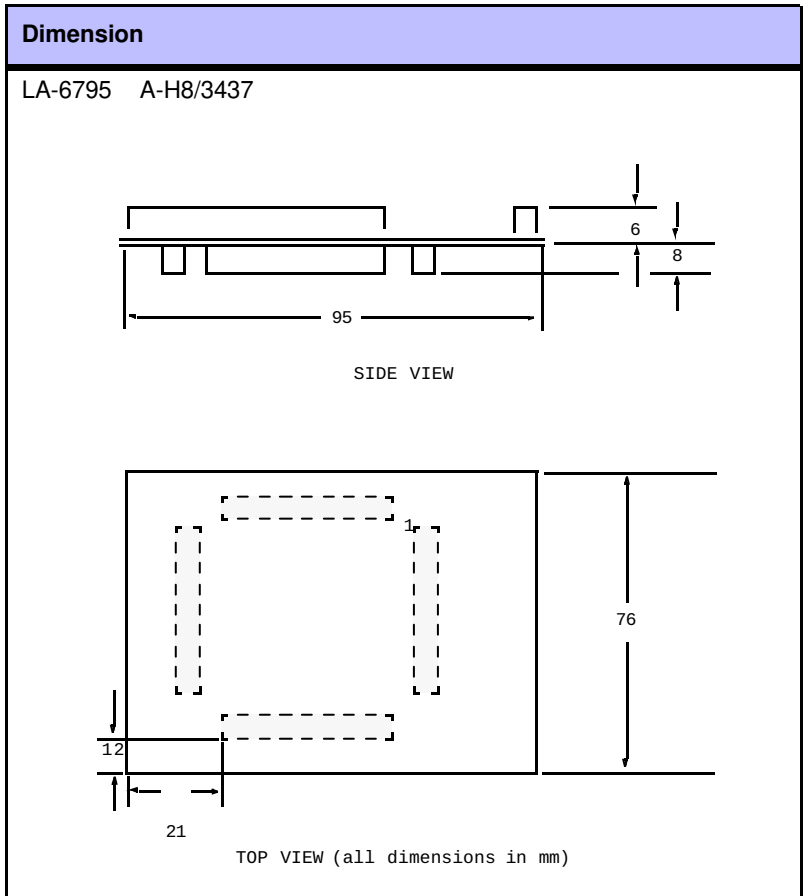

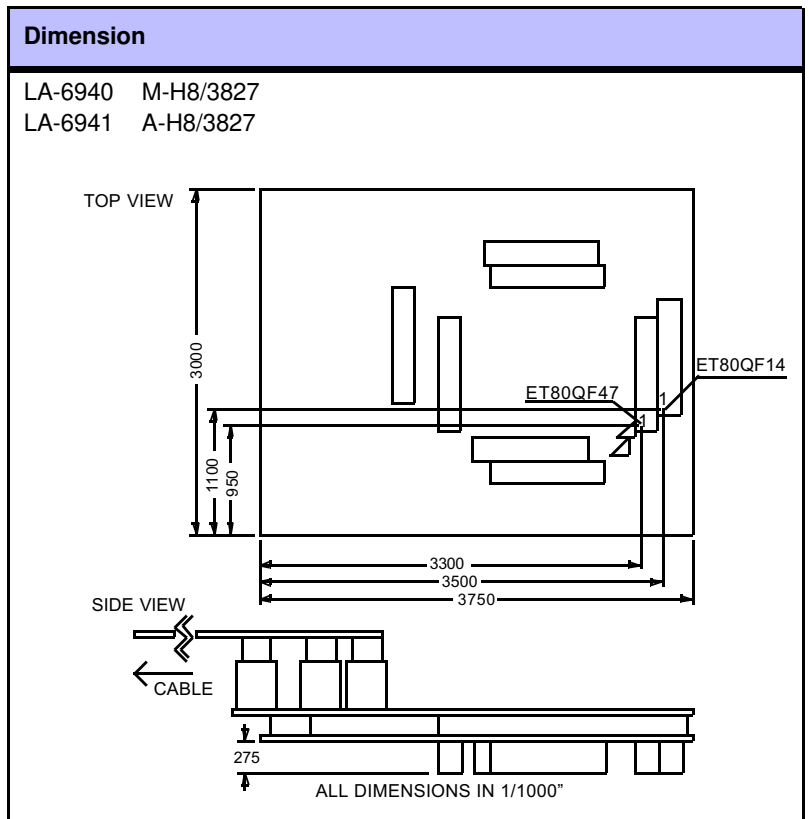

Dimension

LA-6741	M-H8/325
LA-6742	M-H8/329/338
LA-6743	M-H8/330
LA-6744	M-H8/350
LA-6792	M-H8/3334
LA-6793	M-H8/3297
LA-6794	M-H8/3437
LA-6951	M-H8/3217
LA-6745	M-H8/520
LA-6746	M-H8/532
LA-6747	M-H8/534R
LA-7300	M-H8/534S
LA-7301	M-H8/537

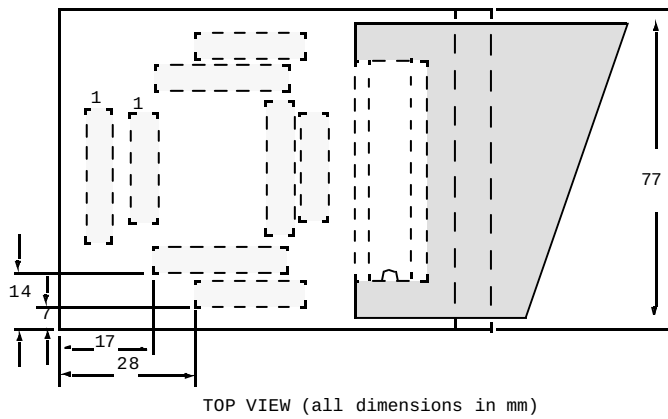
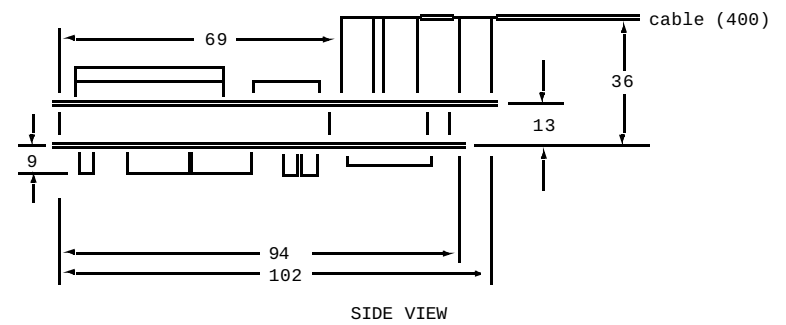

Dimension

LA-6953 M-H8/3814/3834

LA-6955 A-H8/3814/3834

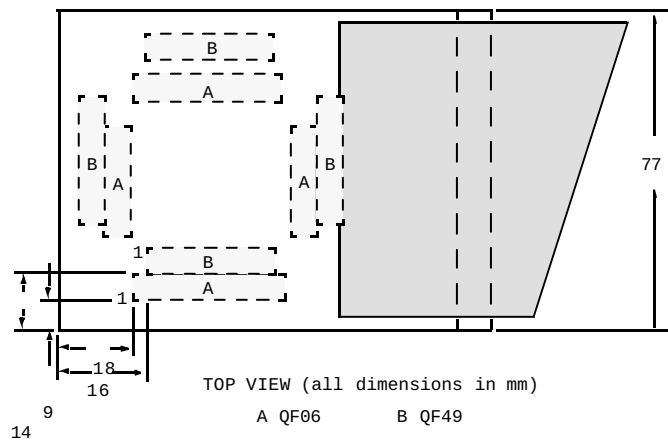
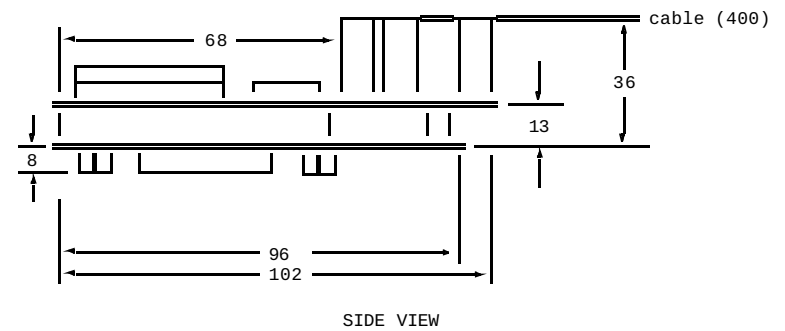

LA-6734 M-H8/310

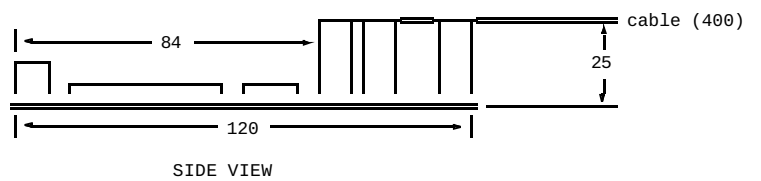

Connectors

On each emulation module there are half-size connectors to:

- Connect the emulation module directly to the target by providing the corresponding connectors also on the target hardware

- Connect a standard adapter from Emulation Technologie, YAMAICHI, AMP etc.

The following table lists the physical dimensions of these half size connectors.

CPU	Dimension
H8/3006 H8/3007 H8/3060 H8/3061 H8/3062 H8/3064 H8/3065 H8/3066 H8/3067 H8/3812 H8/3813 H8/3833 H8/3834 H8/3835 H8/3836 H8/3837	<p>ET100-QF06</p>

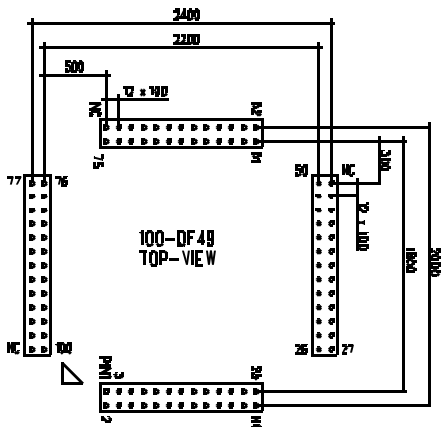
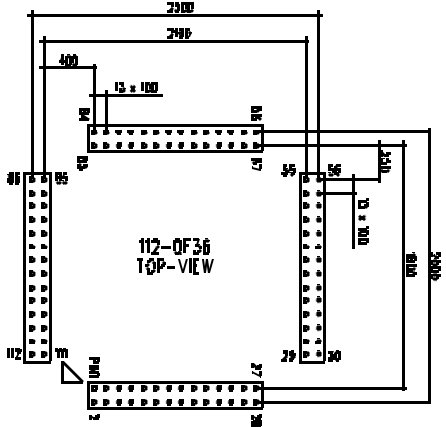
CPU	Dimension
H8/3002 H8/3006 H8/3007 H8/3040 H8/3040 H8/3041 H8/3041 H8/3042 H8/3042 H8/3044 H8/3045 H8/3047 H8/3048 H8/3048F H8/3060 H8/3061 H8/3062 H8/3064 H8/3065 H8/3066 H8/3067 H8/3434 H8/3434F H8/3436 H8/3437 H8/3812 H8/3813 H8/3833 H8/3834 H8/3835 H8/3836 H8/3837	ET100-QF49 
H8/3003	ET112-QF36 

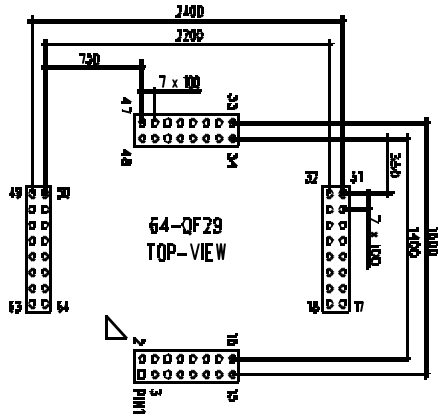
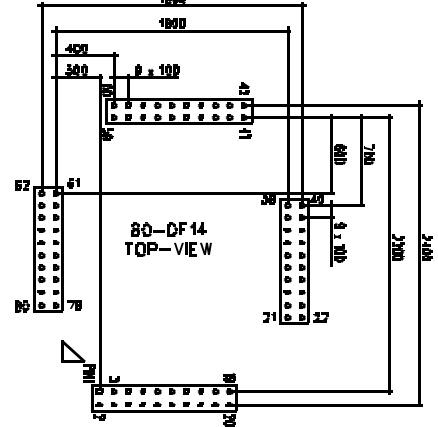
CPU	Dimension
H8/3202 H8/3212 H8/3214 H8/3216 H8/3217 H8/322 H8/323 H8/324 H8/325 H8/3256 H8/3257 H8/3292 H8/3294 H8/3296 H8/3297 H8/3640 H8/3641 H8/3642 H8/3643 H8/3644	ET64-QF29  <p style="text-align: center;">64-QF29 TOP-VIEW</p>
H8/3001 H8/3004 H8/3005 H8/3030 H8/3031 H8/3032 H8/330 H8/3334Y H8/3334YF H8/3336Y H8/3337Y H8/336 H8/337 H8/338 H8/3394 H8/3396 H8/3397	ET80-QF14  <p style="text-align: center;">80-QF14 TOP-VIEW</p>

CPU	Dimension
H8/3001 H8/3004 H8/3005 H8/3030 H8/3030 H8/3031 H8/3031 H8/3032 H8/3032 H8/3202 H8/3212 H8/3214 H8/3216 H8/3217 H8/3292 H8/3294 H8/3296 H8/3297 H8/3334Y H8/3334YF H8/3336Y H8/3337Y H8/3394 H8/3396 H8/3397 H8/3640 H8/3641 H8/3642 H8/3643 H8/3644	ET80-QF47

Adapter

The adapters connect in different ways

- With Clip-Over Adapters the CPU can stay on the target board.
- With Solder-ON adapters the CPU must be removed

- YAMAICHI and AMP adapters fit to the CPU socket

The following table lists the physical dimensions of these adapters.

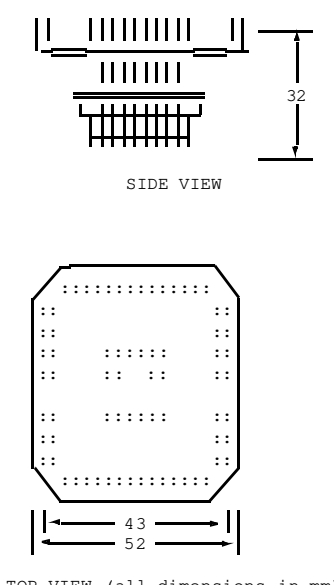
Socket CPU	Adapter
ET100-QF06 H8/3006 H8/3007 H8/3060 H8/3061 H8/3062 H8/3064 H8/3065 H8/3066 H8/3067 H8/3812 H8/3813 H8/3833 H8/3834 H8/3835 H8/3836 H8/3837	ET-1030 ET100-SET-QF06 Surface Mountable Adapter for ET100 to QF06  <p style="text-align: center;">SIDE VIEW</p> <p style="text-align: center;">TOP VIEW (all dimensions in mm)</p>

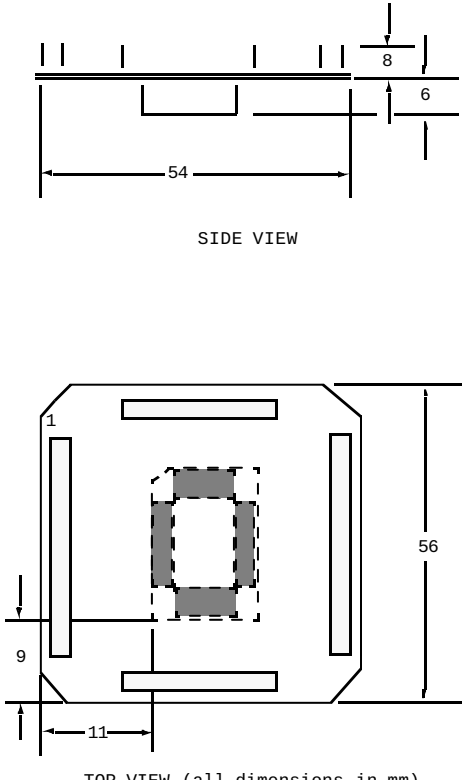
Socket CPU	Adapter
<p>ET100-QF06</p> <p>H8/3006 H8/3007 H8/3060 H8/3061 H8/3062 H8/3064 H8/3065 H8/3066 H8/3067 H8/3812 H8/3813 H8/3833 H8/3834 H8/3835 H8/3836 H8/3837</p>	<p>YA-1031 ET100-EYA-QF06 Emul. Adapter for YAMAICHI socket ET100-QF06</p>  <p>SIDE VIEW</p> <p>TOP VIEW (all dimensions in mm)</p>

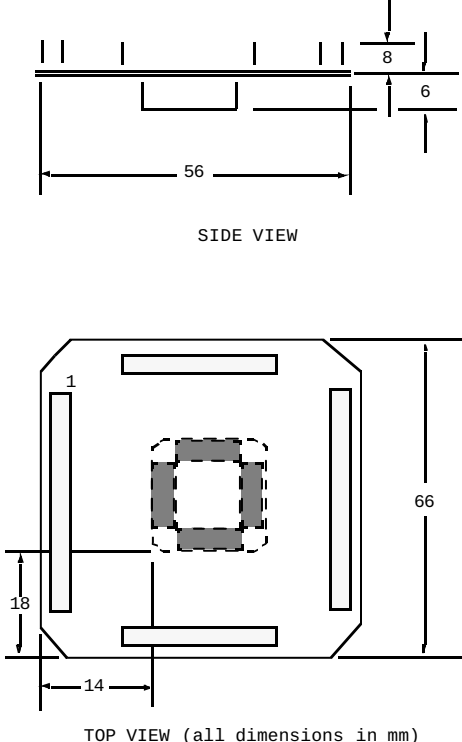
Socket CPU	Adapter
ET100-QF49 H8/3002 H8/3006 H8/3007 H8/3040 H8/3041 H8/3042 H8/3044 H8/3045 H8/3047 H8/3048 H8/3048F H8/3060 H8/3061 H8/3062 H8/3064 H8/3065 H8/3066 H8/3067 H8/3434 H8/3434F H8/3436 H8/3437 H8/3812 H8/3813 H8/3833 H8/3834 H8/3835 H8/3836 H8/3837	YA-1091 ET100-EYA-QF49 Emul. Adapter for YAMAICHI socket ET100-QF49  <p>The technical drawing consists of two views: a side view and a top view. The side view shows a profile of the adapter with a total length of 56 mm. It features a central notch and a small protrusion on the right side with a height of 6 mm and a width of 8 mm. The top view shows a square-shaped footprint with a side length of 66 mm. It includes a central square hole with a side length of 14 mm and a vertical slot on the left side that is 18 mm wide. A small dimension of 1 mm is indicated near the top-left corner.</p> <p>SIDE VIEW</p> <p>TOP VIEW (all dimensions in mm)</p>

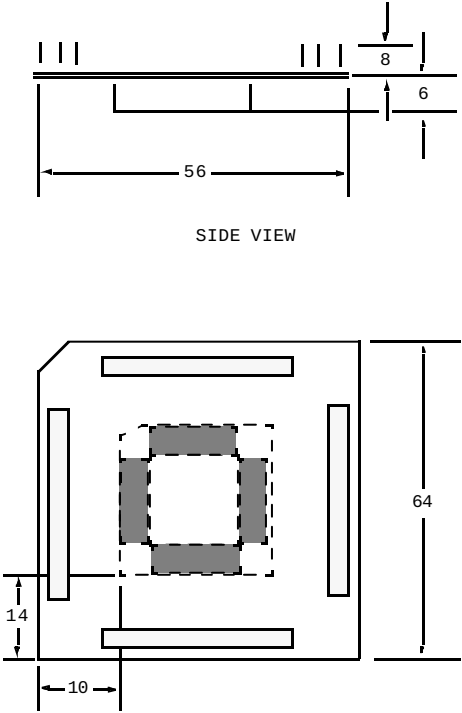
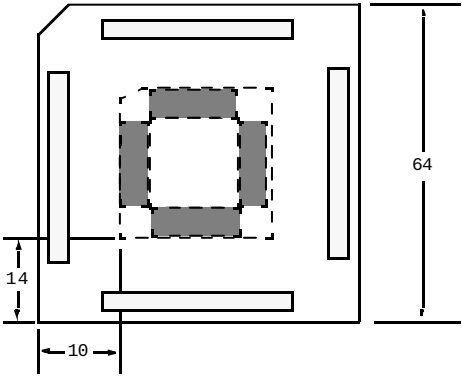
Socket CPU	Adapter
ET112-QF36 H8/3003	<p data-bbox="927 371 1422 456">YA-1101 ET112-EYA-QF36 Emul. Adapter for YAMAICHI socket ET112-QF36</p>  <p data-bbox="1134 734 1241 752">SIDE VIEW</p>  <p data-bbox="1023 1234 1358 1252">TOP VIEW (all dimensions in mm)</p>

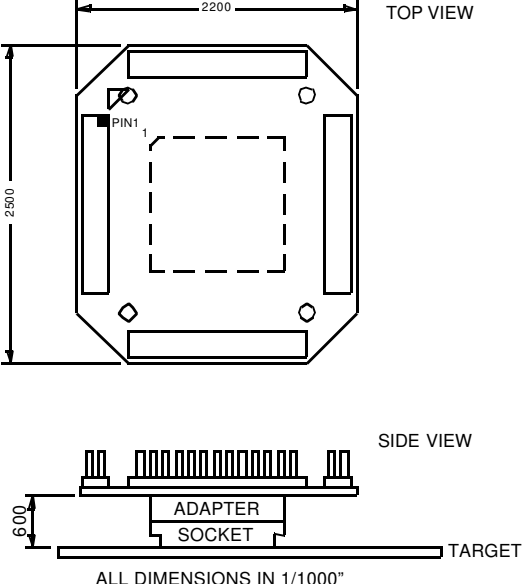
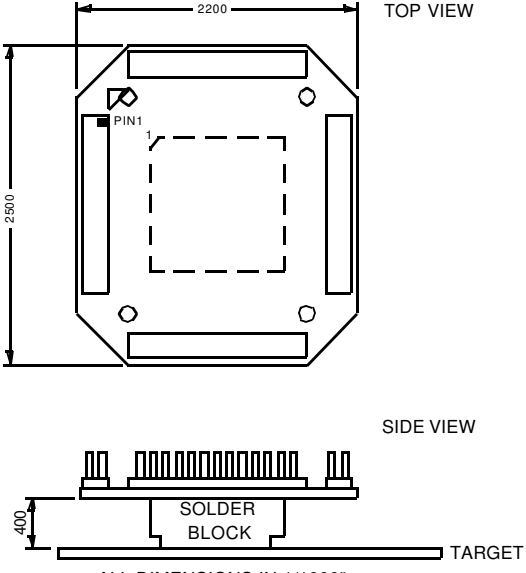
Socket CPU	Adapter
<p>ET112-QF36</p> <p>H8/3003</p>	<p>TO-1290 ET112-ETO-QF36 Emul. Adapter for TO socket ET112-QF36</p>  <p>ALL DIMENSIONS IN 1/1000"</p>
<p>ET112-QF36</p> <p>H8/3003</p>	<p>TO-1291 ET112-STO-QF36 Emul. Adapter TO-surface mount. ET112-QF36</p>  <p>ALL DIMENSIONS IN 1/1000"</p>

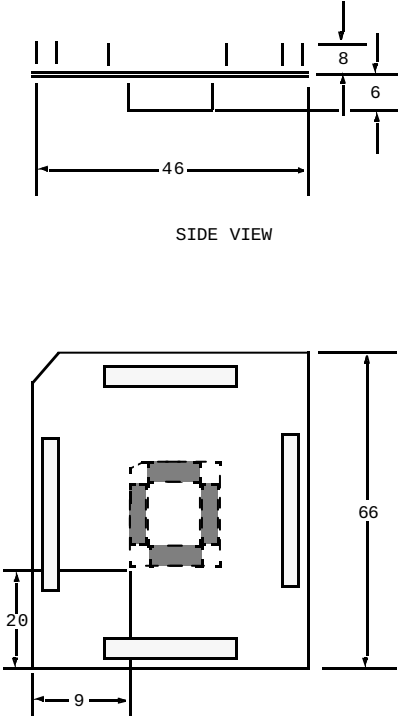
Socket CPU	Adapter
<p>ET64-QF29</p> <p>H8/3202 H8/3212 H8/3214 H8/3216 H8/3217 H8/322 H8/323 H8/324 H8/325 H8/3256 H8/3257 H8/3292 H8/3294 H8/3296 H8/3297 H8/3640 H8/3641 H8/3642 H8/3643 H8/3644</p>	<p>YA-1121 ET64-EYA-QF29 Emul. Adapter for YAMAICHI socket ET064-QF29</p>  <p>SIDE VIEW</p> <p>TOP VIEW (all dimensions in mm)</p>

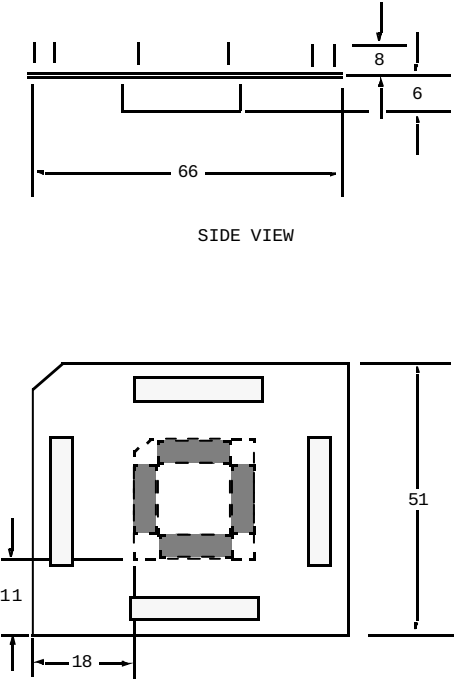
Socket CPU	Adapter
ET80-QF14 H8/3001 H8/3004 H8/3005 H8/3030 H8/3031 H8/3032 H8/330 H8/3334Y H8/3334YF H8/3336Y H8/3337Y H8/336 H8/337 H8/338 H8/3394 H8/3396 H8/3397	YA-1131 ET80-EYA-QF14 Emul. Adapter for YAMAICHI socket ET080-QF14  <p>The technical drawing consists of two views: a side view and a top view. The side view shows a profile of the adapter with a total length of 66 mm. It features a central notch with a width of 8 mm and a depth of 6 mm. The top view shows a rectangular footprint with a width of 18 mm and a height of 51 mm. A central square area is indicated with a dashed line, representing the socket interface. The dimensions are provided in millimeters.</p> <p>SIDE VIEW</p> <p>TOP VIEW (all dimensions in mm)</p>

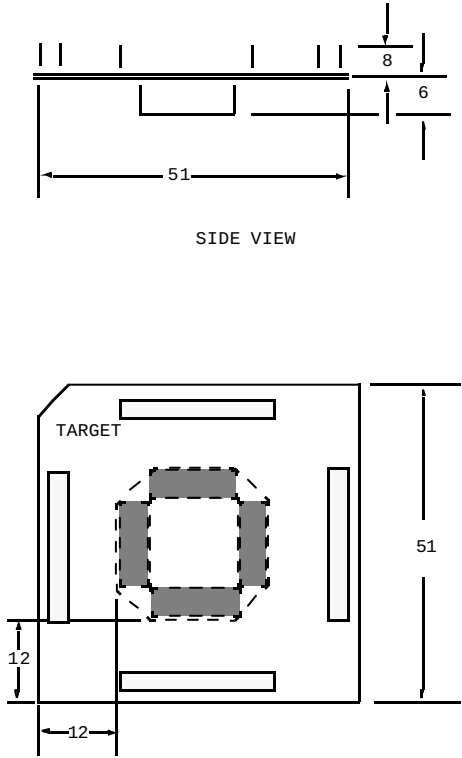
Socket CPU	Adapter
ET80-QF47 H8/3001 H8/3004 H8/3005 H8/3030 H8/3031 H8/3032 H8/3202 H8/3212 H8/3214 H8/3216 H8/3217 H8/3292 H8/3294 H8/3296 H8/3297 H8/3334Y H8/3334YF H8/3336Y H8/3337Y H8/3394 H8/3396 H8/3397 H8/3640 H8/3641 H8/3642 H8/3643 H8/3644	YA-1081 ET80-EYA-QF47 Emul. Adapter for YAMAICHI socket ET080-QF47  <p style="text-align: center;">SIDE VIEW</p> <p style="text-align: center;">TOP VIEW (all dimensions in mm)</p>

Available Tool Chain

TRACE32 provides a complete set of development tools for the H8 family. This includes:

- The In-Circuit Emulator TRACE32-ICE
- The ROM Monitor based In-Circuit Debugger TRACE32-ICD

- Evaluation boards, which can be used until the target hardware is available.

The following list give an overview which development tools are available for the specific derivatives of the H8-family.

CPU	ICE	FIRE	ICD DEBUG	ICD MONITOR	ICD TRACE	POWER INTEGRATOR	INSTRUCTION SIMULATOR
H8/3001	YES			YES			YES
H8/3002	YES			YES			YES
H8/3003	YES			YES			YES
H8/3004	YES			YES			YES
H8/3005	YES			YES			YES
H8/3006	YES	YES		YES			YES
H8/3007	YES	YES		YES			YES
H8/3030	YES			YES			YES
H8/3031	YES			YES			YES
H8/3032	YES			YES			YES
H8/3040	YES			YES			YES
H8/3041	YES			YES			YES
H8/3042	YES			YES			YES
H8/3044	YES	YES		YES			YES
H8/3045	YES	YES		YES			YES
H8/3047	YES	YES		YES			YES
H8/3048	YES	YES		YES			YES
H8/3048F	YES			YES			YES
H8/3060	YES	YES		YES			YES
H8/3061	YES	YES		YES			YES
H8/3062	YES	YES		YES			YES
H8/3064	YES	YES		YES			YES
H8/3065	YES	YES		YES			YES
H8/3066	YES	YES		YES			YES
H8/3067	YES	YES		YES			YES
H8/3101	YES						YES
H8/3102	YES						YES
H8/3202	YES						YES
H8/3212	YES						YES
H8/3214	YES						YES
H8/3216	YES						YES

CPU	ICE	FIRE	ICD DEBUG	ICD MONITOR	ICD TRACE	POWER INTEGRATOR	INSTRUCTION SIMULATOR
H8/3217	YES						YES
H8/322	YES						YES
H8/323	YES						YES
H8/324	YES						YES
H8/325	YES						YES
H8/3256	YES						YES
H8/3257	YES						YES
H8/326	YES						YES
H8/327	YES						YES
H8/328	YES						YES
H8/329	YES						YES
H8/3292	YES						YES
H8/3294	YES						YES
H8/3296	YES						YES
H8/3297	YES						YES
H8/330	YES						YES
H8/3334Y	YES						YES
H8/3334YF	YES						YES
H8/3336Y	YES						YES
H8/3337Y	YES						YES
H8/336	YES						YES
H8/337	YES						YES
H8/338	YES						YES
H8/3394	YES						YES
H8/3396	YES						YES
H8/3397	YES						YES
H8/3434	YES						YES
H8/3434F	YES						YES
H8/3436	YES						YES
H8/3437	YES						YES
H8/350	YES						YES
H8/3640	YES						YES
H8/3641	YES						YES
H8/3642	YES						YES
H8/3643	YES						YES
H8/3644	YES						YES
H8/3812	YES						YES
H8/3813	YES						YES
H8/3833	YES						YES
H8/3834	YES						YES
H8/3835	YES						YES
H8/3836	YES						YES

CPU	ICE	FIRE	ICD DEBUG	ICD MONITOR	ICD TRACE	POWER INTEGRATOR	INSTRUCTION SIMULATOR
H8/3837	YES						YES
H8/520	YES						
H8/532	YES						
H8/534R	YES						
H8/534S	YES						
H8/536R	YES						
H8/536S	YES						
H8/537	YES						

Order Information

Module Description

OrderNo Code	Text
LA-6740 ICE-H8	ICE-H8 Base Module Base module for Renesas H8 family
LA-6741 M-H8/325	Module Top H8/325 supports H8/322, 323, 324, 325, 3256, 3257, 10 MHz with Module Bottom H8/325/3257 Series
LA-6791 A-H8/300-F	Module Bottom H8/325/3257 Series PLCC68 Adapter for H8/322, 323, 324, 325, 3256, 3257 QFP64 Adapter for H8/322, 323, 324, 325, 3256, 3257 DIL64 Adapter for H8/322, 323, 324, 325, 3256, 3257 QFP64 requires ET64-QF29
LA-6742 M-H8/329/338	Module Top H8/329/338 supports H8/326..329, 10 MHz, H8/336..338, 10 MHz
LA-6743 M-H8/330	Module Top H8/330 supports H8/330, 10 MHz
LA-6792 M-H8/3334	Module Top H8/3334 supports H8/3397, 3396, 3394, 3337, 3336, 3334Y, 3334YF at 16MHz QFP80, TQFP80 requires LA-6798 PLCC84 requires LA-6739
LA-6744 M-H8/350	Module Top H8/350 supports H8/350, 10 MHz
LA-6739 A-H8/300-B	Module Bottom H8/329, 330, 338, 350, 3334 PLCC68-Adapter for H8/326..329 PLCC84-Adapter for H8/330, 336..338, 350 DIL64S-Adapter for H8/326..329 PLCC84-Adapter for H8/3397, 3396, 3394 PLCC84-Adapter for H8/3337, 3336, 3334Y, 3334YF
LA-6738 A-H8/300-A	Module Bottom H8/322..325, 330, 336..338, 350 PLCC68-Adapter for H8/322..325, 3256, 3257 PLCC84-Adapter for H8/330, 336..338, 350
LA-6798 A-H8/300-C	Module Bottom H8/330, 338, 350, 3334, 3397 QFP80 Adapter for H8/330, 336..338, 350 QFP80, TQFP80 Adapter for H8/3397, 3396, 3394 QFP80, TQFP80 Adapter for H8/3337, 3336, 3334Y, 3334YF TQFP80 requires ET80-QF47 QFP80 requires ET80-QF14
LA-6730 M-H8/3003	Module Top H8/3003 supports H8/3002-3003, H8/3040-3042, with module bottom A-H8/3003 supports H8/3001 with module bottom A-H8/3001 supports H8/3004, 3005 with module bottom A-H8/3004/3005
LA-6956 A-H8/3001	Module Bottom H8/3001 QFP80, TQFP80 Adapter for H8/3001 QFP80 requires ET80-QF14 TQFP80 requires ET80-QF47

OrderNo Code	Text
LA-6732 A-H8/3003	Module Bottom H8/3003 QFP100, TQFP100 Adapter for H8/3040-3042, H8/3002 QFP112 Adapter for H8/3003 QFP100, TQFP100 requires ET100-QF49 QFP112 requires ET112-QF36
LA-6797 A-H8/3004/3005	Module Bottom H8/3004, 3005, 3078, 3079 QFP80, TQFP80 Adapter for H8/3004, 3005, 3078, 3079 QFP80 requires ET80-QF14 TQFP80 requires ET80-QF47
LA-6731 M-H8/3048	Module Top H8/3048 supports H8/3040-3042 supports H8/3044, 3045, 3047, 3048 supports H8/3030-3032 with module bottom A-H8/3048/3032-1 and module bottom A-H8/3048/3032-2
LA-6733 A-H8/3048/3032	Module Bottom H8/3048/3032 TQFP80 Adapter for H8/3030-3032 QFP100, TQFP100 Adapter for H8/3040-3042 QFP100, TQFP100 Adapter for H8/3044, 3045, 3047, 3048 TQFP80 requires ET80-QF47 QFP100, TQFP100 requires ET100-QF49
LA-6735 A-H8/3032	Module Bottom H8/3032 QFP80 Adapter for H8/3030-3032 TQFP80 Adapter for H8/3030-3032 QFP80 requires ET80-QF14 TQFP80 requires ET80-QF47
LA-6793 M-H8/3297	Module Top H8/3297 supports H8/3297, 3296, 3294, 3292 at 16MHz
LA-6796 A-H8/300-E	Module Bottom H8/3297 Series TQFP80 Adapter for H8/3292, 3294, 3296, 3297 QFP64 Adapter for H8/3292, 3294, 3296, 3297 DIL64 Adapter for H8/3292, 3294, 3296, 3297 TQFP80 requires ET80-QF47 QFP64 requires ET64-QF29
LA-6794 M-H8/3437	Module Top H8/3437 supports H8/3434-3437, 16MHz
LA-6795 A-H8/3437	Module Bottom H8/3437 QFP100, TQFP100 Adapter for H8/3434-3437 QFP100, TQFP100 requires ET100-QF49
LA-6951 M-H8/3217	Module Top H8/3217 supports H8/3202, 3212, 3214, 3216, 3217
LA-6799 A-H8/300-D	Module Bottom H8/3217 Series TQFP80 Adapter for H8/3202, 3212, 3214, 3216, 3217 QFP64 Adapter for H8/3202, 3212, 3214, 3216, 3217 DIL64 Adapter for H8/3202, 3212, 3214, 3216, 3217 TQFP80 requires ET80-QF47 QFP64 requires ET64-QF29
LA-6952 M-H8/3644	Module Top H8/3644 family supports H8/3640-3644 with module bottom LA-6954
LA-6954 A-H8/3644	Module Bottom H8/3644 family TQFP80 Adapter for H8/3640-3644 QFP64 Adapter for H8/3640-3644 DIL64 Adapter for H8/3640-3644 TQFP80 requires ET80-QF47 QFP64 requires ET64-QF29

OrderNo Code	Text
LA-6953 M-H8/3814/ 3834	Module Top H8/3814/3834 family supports H8/3812-3814, H8/3833-3837 with module bottom LA-6955
LA-6955 A-H8/3814/3834	Module Bottom H8/3814/3834 family ET100-QF06-Adapter for H8/3812-3814, H8/3833-3837 ET100-QF49-Adapter for H8/3812-3814, H8/3833-3837
LA-6940 M-H8/3827	Module Top H8/3827 supports H8/3827 and H8/3867 with module bottom A-H8/3827
LA-6941 A-H8/3827	Module Bottom H8/3827 Support H8/3827 and H8/3867 Adaption ET80-QF14
LA-6957 M-H8/3067	Module Top H8/3067 supports H8/3006/3007, H8/3060-3062 and H8/3064-3067 with module bottom A-H8/3067
LA-6958 A-H8/3067	Module Bottom H8/3067 QFP100, TQFP100 Adapter for H8/3006/3007, H8/3060-62 and H8/3064-67 QFP100 requires ET100-QF49 or ET100-QF06 TQFP100 requires ET100-QF49
LA-6745 M-H8/520	Module Top H8/520 supports H8/520, 10 MHz
LA-6746 M-H8/532	Module Top H8/532 supports H8/532, 10 MHz
LA-6747 M-H8/534R	Module Top H8/534R,536R supports H8/534R, H8/536R, 10 MHz
LA-7300 M-H8/534S	Module H8/534S/536S supports H8/534S, H8/536S, 16 MHz
LA-7301 M-H8/537	Module H8-537 supports H8/537, 16 MHz
LA-6737 A-H8/500-8	Module Bottom H8/520, 532, 534, 536, 537 DIL64-Adapter for H8/520 PLCC68-Adapter for H8/520 PLCC84-Adapter for H8/532, 534R, 534S, 536R, 536S, 537

Detailed Order Information

Order No.	Code	Text
LA-6740	ICE-H8	ICE-H8 Base Module
LA-6741	M-H8/325	Module Top H8/325
LA-6791	A-H8/300-F	Module Bottom H8/325/3257 Series

Order No.	Code	Text
LA-6742	M-H8/329/338	Module Top H8/329/338
LA-6743	M-H8/330	Module Top H8/330
LA-6792	M-H8/3334	Module Top H8/3334
LA-6744	M-H8/350	Module Top H8/350
LA-6739	A-H8/300-B	Module Bottom H8/329, 330, 338, 350, 3334
LA-6738	A-H8/300-A	Module Bottom H8/322..325, 330, 336..338, 350
LA-6798	A-H8/300-C	Module Bottom H8/330, 338, 350, 3334, 3397
LA-6730	M-H8/3003	Module Top H8/3003
LA-6956	A-H8/3001	Module Bottom H8/3001
LA-6732	A-H8/3003	Module Bottom H8/3003
LA-6797	A-H8/3004/3005	Module Bottom H8/3004, 3005, 3078, 3079
LA-6731	M-H8/3048	Module Top H8/3048
LA-6733	A-H8/3048/3032	Module Bottom H8/3048/3032
LA-6735	A-H8/3032	Module Bottom H8/3032
LA-6793	M-H8/3297	Module Top H8/3297
LA-6796	A-H8/300-E	Module Bottom H8/3297 Series
LA-6794	M-H8/3437	Module Top H8/3437
LA-6795	A-H8/3437	Module Bottom H8/3437
LA-6951	M-H8/3217	Module Top H8/3217
LA-6799	A-H8/300-D	Module Bottom H8/3217 Series
LA-6952	M-H8/3644	Module Top H8/3644 family
LA-6954	A-H8/3644	Module Bottom H8/3644 family
LA-6953	M-H8/3814/3834	Module Top H8/3814/3834 family
LA-6955	A-H8/3814/3834	Module Bottom H8/3814/3834 family
LA-6940	M-H8/3827	Module Top H8/3827
LA-6941	A-H8/3827	Module Bottom H8/3827
LA-6957	M-H8/3067	Module Top H8/3067
LA-6958	A-H8/3067	Module Bottom H8/3067
LA-6745	M-H8/520	Module Top H8/520
LA-6746	M-H8/532	Module Top H8/532
LA-6747	M-H8/534R	Module Top H8/534R,536R
LA-7300	M-H8/534S	Module H8/534S/536S
LA-7301	M-H8/537	Module H8-537
LA-6737	A-H8/500-8	Module Bottom H8/520, 532, 534, 536, 537
Additional Options		
LA-9547	BGA256-CPU-ADAPTER	CPU Test Adapter for BGA256 (MPC850)
LA-7216	BGA357-CPU-ADAPTER	CPU Test Adapter for BGA357 (MPC860)
TO-1260	ET100-ETO-QF06	Emul. Adapter for TO socket ET100-QF06
TO-1250	ET100-ETO-QF49	Emul. Adapter for T0 socket ET100-QF49
TO-1255	ET100-ETO-SE	Emul. Adapter for T0 socket ET100-SE 0.4mm

Order No.	Code	Text
YA-1031	ET100-EYA-QF06	Emul. Adapter for YAMAICHI socket ET100-QF06
YA-1091	ET100-EYA-QF49	Emul. Adapter for YAMAICHI socket ET100-QF49
ET-1030	ET100-SET-QF06	Surface Mountable Adapter for ET100 to QF06
ET-1092	ET100-SET-QF49	Surface Mountable Adapter for ET100-QF49
TO-1261	ET100-STO-QF06	Emul. Adapter TO-surface mount. ET100-QF06
TO-1251	ET100-STO-QF49	Emul. Adapter TO-surface mount. ET100-QF49
LA-1105	ET112-CPU-QF36	CPU Test Adapter for ET112-QF36
TO-1290	ET112-ETO-QF36	Emul. Adapter for TO socket ET112-QF36
YA-1101	ET112-EYA-QF36	Emul. Adapter for YAMAICHI socket ET112-QF36
ET-1100	ET112-SET-QF36	Surface Mountable Adapter for ET112-QF36
TO-1291	ET112-STO-QF36	Emul. Adapter TO-surface mount. ET112-QF36
YA-1142	ET120-EYA-QF56	Emul. Adapter for YAMAICHI socket ET120-QF56
TO-1240	ET64-ETO-QF29	Emul. Adapter for T0 socket ET64-QF29
YA-1121	ET64-EYA-QF29	Emul. Adapter for YAMAICHI socket ET064-QF29
ET-1122	ET64-SET-QF29	Surface Mountable Adapter for QF29
TO-1275	ET80-ETO-QF14	Emul. Adapter for T0 socket ET080-QF14
TO-1270	ET80-ETO-QF47	Emul. Adapter for T0 socket ET080-QF47
YA-1131	ET80-EYA-QF14	Emul. Adapter for YAMAICHI socket ET080-QF14
YA-1081	ET80-EYA-QF47	Emul. Adapter for YAMAICHI socket ET080-QF47
ET-1130	ET80-SET-QF14	Surface Mountable Adapter for ET80-QF14
TO-1276	ET80-STO-QF14	Emul. Adapter TO-surface mount. ET080-QF14
TO-1271	ET80-STO-QF47	Emul. Adapter TO-surface mount. ET080-QF47
LA-7528	MON-H8	ROM Monitor for H8/300H and H8S family on ESI
LA-6450	PA64	Port Analyzer
LA-1923	PLCC-BLOCK-68	PLCC Block 68 Pins
LA-1924	PLCC-BLOCK-84	PLCC Block 84 Pins
LA-1926	PLCC-TEST-ADAPTER-68	PLCC Test Adapter 68 Pins
LA-1927	PLCC-TEST-ADAPTER-84	PLCC Test Adapter 84 Pins
LA-8808	SIM-H8	Instruction Set Simulator for H8 and H8S

Contact

International Representative

Australia

Embedded Logic Solutions Pty Ltd
Mr. Ramzi Kaffan
23/1 Maitland Place
Baulkham Hills NSW 2153
Phone: ++61 02 9899 1703
FAX: ++61 02 9899 1723
EMAIL: sales@emlogic.com.au

Austria

Lauterbach Datentechnik GmbH
Mr. Norbert Weiss
Fichtenstr. 27
D-85649 Hofolding
Phone: ++49 8104 8943 183
FAX: ++49 8104 8943 170
EMAIL: info_de@lauterbach.com

Belgium

Tritec Benelux B.V.
Mr. Robbert de Voogt
Stationspark 550
NL-3364 DA Sliedrecht
Phone: ++31 184 41 41 31
FAX: ++31 184 42 36 11
EMAIL: software@tritec.nl

Brazil

ANACOM Software e Hardware Ltd
Mr. Rodrigo Ferreira
Rua Nazareth, 807, Bairro Barc
BR-09551-200 Sao Caetano do Sul
Phone: 0055 11 3422-4200
FAX: 0055 11 3422-4242
EMAIL: rferreira@anacom.com.br

Canada

Lauterbach Inc.
4 Mount Royal Ave.
USA-Marlborough, MA 01752
Phone: ++1 508 303 6812
FAX: ++1 508 303 6813
EMAIL: info_us@lauterbach.com

China

Suzhou Lauterbach Technologies Co.,Ltd.
Mr. Yue Zhao
Room 1605, Xing Hai International Square
No.200, Xing Hai Street
Suzhou, 215021 PR of China
Phone: 0086-512 6265 8030
FAX: 0086-512 6265 8032
EMAIL: info_cn@lauterbach.com

Denmark

Nohau Danmark A/S
Mr. Flemming Jensen
Klausdalsbrovej 493
DK-2730 Herlev
Phone: ++45 44 52 16 50
FAX: ++45 44 52 26 55
EMAIL: info@nohau.dk

Egypt

Wantech
Mr. Nawara
5 Shafik Ghalie St., Suite 2
Off Pyramids Road, Giza
Cairo 12111
Phone: ++20 2 5848020
FAX: ++20 2 5877303
EMAIL: sales@wantech.net.com

Finland

Nohau
Mr. Leevi Lehtinen
Teknobulevardi 3-5
FI-01531 Vantaa
Phone: ++358 40 546 1469
FAX: ++358 9 2517 8101
EMAIL: leevi.lehtinen@nohau.se

France

Logic Instrument
Mr. Stephane Morice
BP 116
71, route de Saint-Denis
F-95170 Deuil la Barre
Phone: ++33 1 342861 70
FAX: ++33 1 342800 50
EMAIL: s.morice@logic-instrument.com

Germany

Lauterbach Datentechnik GmbH
Mr. Norbert Weiss
Fichtenstr. 27
D-85649 Hofolding
Phone: ++49 8104 8943 0
FAX: ++49 8104 8943 170
EMAIL: info_de@lauterbach.com

Germany North

Lauterbach Datentechnik GmbH
Mr. Klaus Hommann
Leonhardring 5
D-31319 Sehnde
Phone: ++49 5138 6185 0
FAX: ++49 5138 6185 3
EMAIL: klaus.hommann@lauterbach.com

India

Electro Systems Ass. Pvt. Ltd.
Mr. G. V. Gurunatham
4215 JK Complex First Main Rd.
IND-Bangalore 560 021
Phone: ++91 80 23577924
FAX: ++91 80 23475615
EMAIL: esaindia@vsnl.com

Ireland

Lauterbach Ltd.
Mr. Barry Lock
11 Basepoint Enterprise Centre
Stroudley Road
Basingstoke, Hants RG24 8UP
Phone: ++44-1256-333-690
FAX: ++44-1256-336-661
EMAIL: info_uk@lauterbach.com

Israel

Itec Ltd.
Mr. Mauri Gottlieb
P.O.Box 10002
IL-Tel Aviv 61100
Phone: ++972 3 6491202
FAX: ++972 3 6497661
EMAIL: general@itec.co.il

Italy

Lauterbach Srl
Mr. Maurizio Menegotto
Via Enzo Ferrieri 12
I-20153 Milano
Phone: ++39 02 45490282
FAX: ++39 02 45490428
EMAIL: info_it@lauterbach.com

Japan

Lauterbach Japan, Ltd.
Mr. Kenji Furukawa
3-9-5 Shinyokohama
Kouhoku-ku
Yokohama-shi, Japan 222-0033
Phone: ++81-45-477-4511
FAX: ++81-45-477-4519
EMAIL: info@lauterbach.co.jp

Luxemburg

Tritec Benelux B.V.
Mr. Robbert de Voogt
Stationspark 550
NL-3364 DA Sliedrecht
Phone: ++31 184 41 41 31
FAX: ++31 184 42 36 11
EMAIL: software@tritec.nl

Malaysia

Flash Technology
Mr. Teo Kian Hock
No 61, # 04-15 Kaki Bukit Av 1
Shun Li Industrial Park
SGP-Singapore 417943
Phone: ++65 6749 6168
FAX: ++65 6749 6138
EMAIL: teokh@flashtech.com.sg

Netherlands

Tritec Benelux B.V.
Mr. Robbert de Voogt
Stationspark 550
NL-3364 DA Sliedrecht
Phone: ++31 184 41 41 31
FAX: ++31 184 42 36 11
EMAIL: software@tritec.nl

New Zealand

Embedded Logic Solutions Pty Ltd
Mr. Ramzi Kattan
23/1 Maitland Place
Baulkham Hills NSW 2153
Phone: ++61 02 9899 1703
FAX: ++61 02 9899 1723
EMAIL: sales@emlogic.com.au

Norway

Nohau Elektronik AB
Mr. Greger Andersson
Derbyvägen 4
S-21235 Malmö
Phone: ++46 40 59 22 00
FAX: ++46 40 59 22 29
EMAIL: info@nohau.se

Poland

Quantum Sp.z o.o. Korp. Transf
Mr. Czeslaw Bil
ul. Skwierzynska 21
53-521 Wrocław
Phone: ++48 71 362 6356
FAX: ++48 71 362 6357
EMAIL: bil@quantum.com.pl

Portugal

Captura Electronica, SCCL
Mr. Juan Martinez
c/Albert Einstein s/n
Edificio Forum de la Tecnol.
E-08042 Barcelona
Phone: ++34 93 291 76 33
FAX: ++34 93 291 76 35
EMAIL: info@captura-el.com

Singapore

Flash Technology
Mr. Teo Kian Hock
No 61, # 04-15 Kaki Bukit Av 1
Shun Li Industrial Park
SGP-Singapore 417943
Phone: ++65 6749 6168
FAX: ++65 6749 6138
EMAIL: teokh@flashtech.com.sg

South Korea

MDS Technology Co., Ltd.
Mr. Hyunchul Kim
15F Kolon Digital Tower Vilant
#222-7, Guro 3dong, Guro-gu
Seoul, 152-848, ROK
Phone: ++82 2 2106 6000
FAX: ++82 2 2106 6004
EMAIL: trace32@mdstec.com

Spain

Captura Electronica, SCCL
Mr. Juan Martinez
c/Albert Einstein s/n
Edificio Forum de la Tecnol.
E-08042 Barcelona
Phone: ++34 93 291 76 33
FAX: ++34 93 291 76 35
EMAIL: info@captura-el.com

Sweden

Nohau Elektronik AB
Mr. Magnus Engström
Derbyvägen 4
SE-21235 Malmö
Phone: ++46 40 59 22 00
FAX: ++46 40 59 22 29
EMAIL: info@nohau.se

Switzerland

JDT Jberg DatenTechnik
Mr. Andreas Jberg
Zimmerstrasse 2
CH-5734 Reinach AG
Phone: ++41 62 7710 886
FAX: ++41 62 7717 187
EMAIL: Andreas.Jberg@jdt.ch

Taiwan

Superlink Technology Corp.
Mr. Sulin Huang
3F-8, No. 77, Shin-Tai-Wu Rd. Sec1
Taipei Hsien 221, Taiwan, R.O.C.
Phone: ++886 2 26983456
FAX: ++886 2 26983535
EMAIL: info.stc@superlink.com.tw

Turkey

Bildem Bilgisayar Ltd. Sti.
Mr. Hakan Yavuz
Koroglu Cad. 64/3 G.O.Pasa
TR-06700 Ankara
Phone: ++90 312 4472700
FAX: ++90 312 4472702
EMAIL: info@bildem.com.tr

UK

Lauterbach Ltd.
Mr. Barry Lock
11 Basepoint Enterprise Centre
Stroudley Rd
Basingsstoke, Hants RG24 8UP
Phone: ++44 (0) 1256-333690
FAX: ++44 (0) 1256-336661
EMAIL: info_uk@lauterbach.com

USA East

Lauterbach Inc.
Mr. Udo Zoettler
4 Mount Royal Ave.
USA-Marlborough, MA 01752
Phone: ++1 508 303 6812
FAX: ++1 508 303 6813
EMAIL: info_us@lauterbach.com

USA West

Lauterbach Inc.
Mr. Jerry Flake
13256 SW Hillshire Drive
USA-Tigard, OR 97223
Phone: ++1 503 524 2222
FAX: (503) 524 2223
EMAIL: jerry.flake@lauterbach.com

Additional Information

<http://www.lauterbach.com>

Lauterbach Datentechnik GmbH

Fichtenstr. 27
D-85649 Hofolding
Tel. ++49 8104 8943-188 FAX -187
info@lauterbach.com
<http://www.lauterbach.de>

Lauterbach Inc.

4 Mount Royal Ave.
Marlboro MA 01752
Phone (508) 303 6812 FAX (508) 303 6813
info_us@lauterbach.com
<http://www.lauterbach.com/usa>

Lauterbach Ltd.

11 Basepoint Enterprise Ctre Stroudley Road
Basingstoke, Hants RG24 8UP
Phone ++44-1256-333-690 FAX -661
info_uk@lauterbach.com
<http://www.lauterbach.co.uk>

Lauterbach Japan, Ltd.

3-9-5 Shinyokohama Kouhoku-ku
Yokohama-shi Japan 222-0033
Phone ++81-45-477-4511 FAX -4519
info_j@lauterbach.com
<http://www.lauterbach.co.jp>

Lauterbach s.r.l.

Lauterbach s.r.l.
Via Enzo Ferrieri 12
I-20153 Milano
Phone ++39 02 45490282
FAX ++39 02 45490428
info_it@lauterbach.it
<http://www.lauterbach.it>

Suzhou Lauterbach Consulting Co.,Ltd.

Room 1605, Xing Hai International Square
No.200, Xing Hai Street
Suzhou, 215021 PR of China
Phone: 0086-512 6265 8030
FAX: 0086-512 6265 8032
info@lauterbach.cn
<http://www.lauterbach.cn>

Disclaimer

The information presented is intended to give overview information only.
Changes and technical enhancements or modifications can be made with-