

PROBER ACCESSORIES: MICRO POSITIONERS

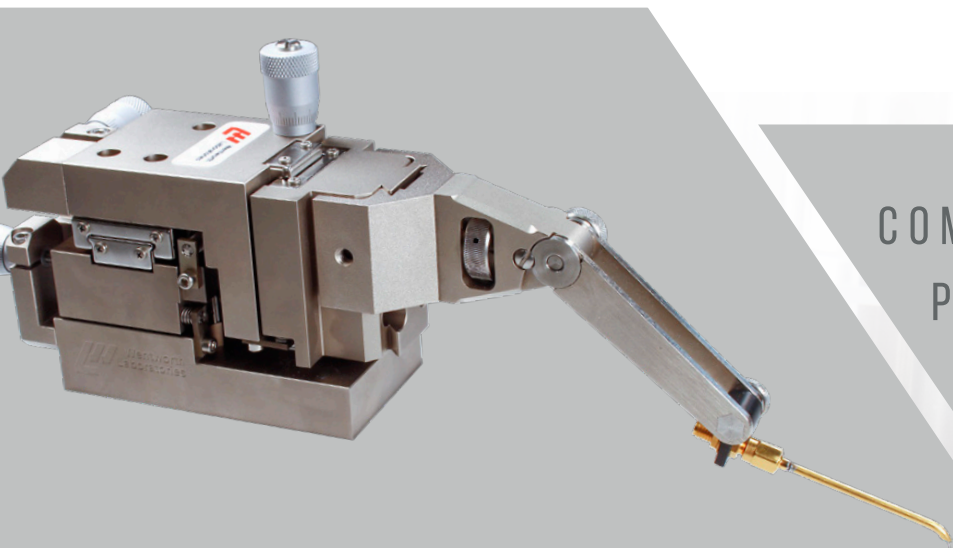

COMPUTER ASSISTED PROBE
PEGASUS™ PROBE
PVX 500
PVX 400

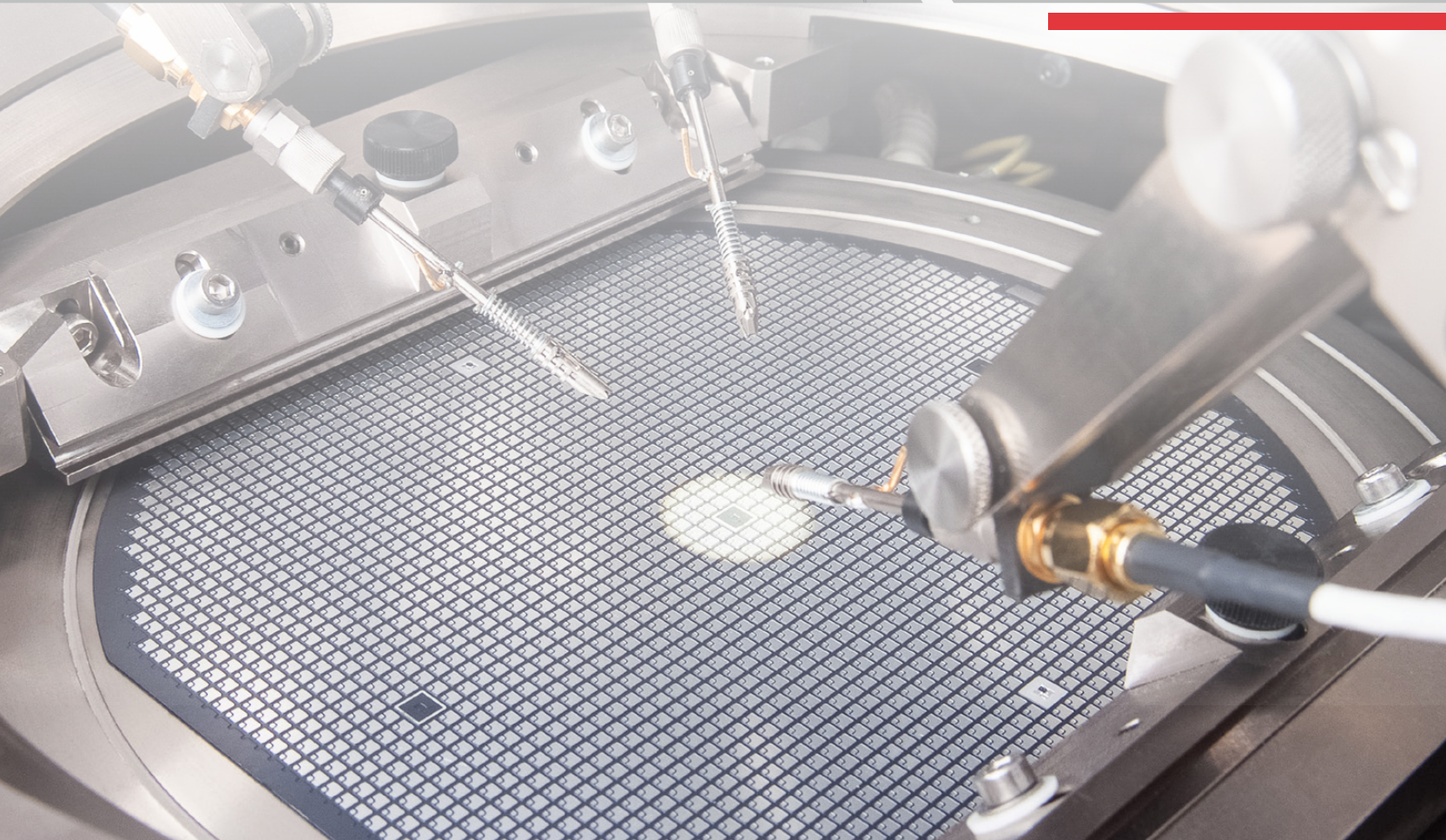

PEGASUS™ CAP

COMPUTER ASSISTED PROBE



KEY FEATURES

- ✓ Fully programmable
- ✓ Submicron resolution
- ✓ Highly repeatable and accurate positioning
- ✓ Powerful, intuitive control and monitoring software
- ✓ Configurable with high voltage/high current probing accessories

DESIGN

Pegasus™ CAP is a fully programmable, automated manipulator for the Wentworth Pegasus™ series of 200 and 300 mm probers, delivering submicron resolution for use in the most demanding test applications.

Pegasus™ CAP can be controlled via keypad or with optional LabMaster™ control and monitoring software. LabMaster™ drives all Pegasus™ CAP functions via a user-friendly graphic interface, providing centralized test setup and control.

APPLICATIONS

A wide range of articulated front ends offers maximum adjustment capability to accurately position the needle holder, of paramount importance when probing inside packaged devices. In addition, Pegasus™ CAP is fully programmable in X, Y and Z axes to successfully resolve alignment when probing packaged devices and offers 30 mm of travel in X, Y and Z axes.

Featuring a vacuum hold down, the CAP manipulator provides a stable probing platform with a quick-release function for fast, easy repositioning of the unit.

SPECIFICATIONS

General	
Base footprint	120 x 110 mm (4.7" x 4.3")
Height	125 mm (4.9") excluding handle
Weight	3 kg
XYZ accuracy	± 1 µm
XYZ repeatability	≤ 0.5 µm
XYZ resolution	0.1 µm
XYZ travel	30 mm
XYZ speed	up to 1 mm/s
Facilities	
Pegasus™ CAP controller	220-240 V/50 Hz and 100-115 V/60 Hz, auto select, 1000 VA
Vacuum	0.5 cfm @ 20 Hg (min)

PVX 500

MICROPOSITIONER

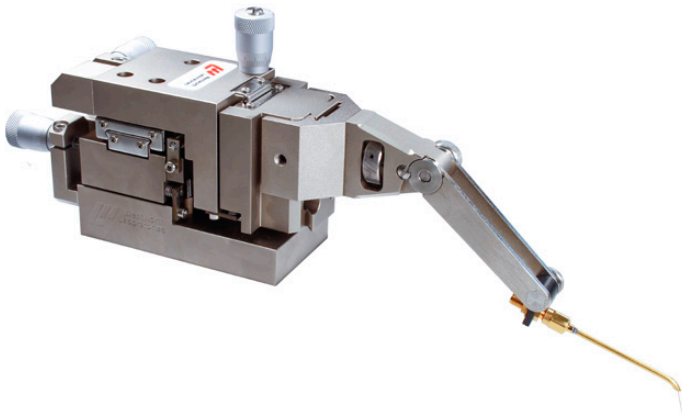

KEY FEATURES

- ✓ Smooth precision positioning
- ✓ Versatile for a wide variety of applications
- ✓ Micrometer driven
- ✓ Easy and quick repositioning with magnetic or vacuum hold down
- ✓ Configurable with high voltage/high current probing accessories

DESIGN

The PVX 500 manual linear motion micromanipulator for analytical probes delivers a highly versatile solution for a variety of applications.

Featuring a choice of either magnetic or vacuum hold down, the PVX 500 micromanipulator provides a rigid probing platform with a quick-release facility for fast, easy repositioning of the manipulator unit.

A wide range of articulated front-ends and needle holder assemblies allows easy integration of the PVX 500 onto most standard systems. In addition, a small footprint and the option of rear adjustment ensures a maximum number of manipulators can be placed on a prober.

PRECISE & ACCURATE POSITIONING

Available with a resolution of down to $0.35 \mu\text{m}/^\circ$, the PVX 500 offers unrivalled accuracy. This is why this micropositioner is ideal not only for semiconductor wafer testing but any application which requires micron, sub-micron or even nanometre positioning.

Wentworth's PVX 500 micrometer drives and recirculating linear slides, provide precise linear motion in all three axes. This allows for ease of positioning onto the finest geometries.

LOW CURRENT

A wide choice of probes and probe holders complements the PVX 500 micromanipulator for most low current applications to less than 10 fA. They are available in different styles including coax with integrated mounting shank, single and dual (series resistor), and Kelvin dual SSMC connections. Optional interface cables complete your probing configuration.

HIGH CURRENT/HIGH VOLTAGE

Our specialist HV and HC probes are designed to carry out power device characterization at wafer level. They are capable of testing with voltage up to 10 kV and current up to 100 A under pulsed current.

SPECIFICATIONS

	PVX 500 - 100 TPI	PVX 500 - 200 TPI
Base footprint	45 x 93.5 mm	
Height	103 mm	
Weight	1 kg vacuum base, without front ends	
Travel	X = 10 mm, Y = 10 mm, Z = 10 mm	
Resolution	0.7 $\mu\text{m}/^\circ$	0.35 $\mu\text{m}/^\circ$
Hold down	Vacuum or magnetic	
Micrometer head drive	100 TPI	200 TPI

PVX 400

MICROPOSITIONER

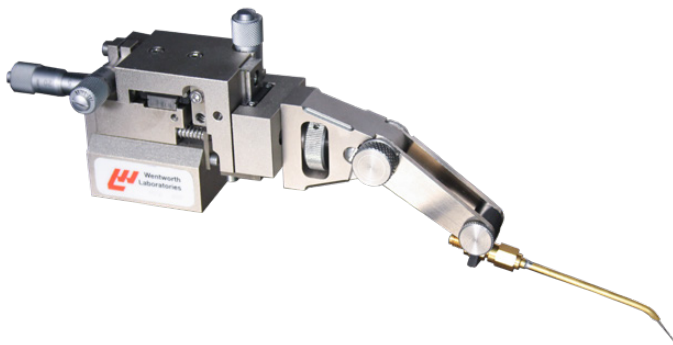

KEY FEATURES

- ✓ Smooth precision positioning
- ✓ Versatile – for a wide variety of applications
- ✓ Micrometer driven
- ✓ Small footprint allows for the placement of many units on a single platform
- ✓ Easy and quick repositioning with magnetic or vacuum hold down

DESIGN

PVX 400 micrometer drives and re-circulating linear slides, provide precise linear motion in all three axes with a resolution of $1.2 \mu\text{m}/^\circ$. This allows for easy positioning onto the finest geometries.

Featuring a choice of either magnetic or vacuum hold down, the PVX 400 manipulator provides a rigid probing platform with a quick release facility for fast, easy repositioning of the manipulator unit.

APPLICATIONS

PVX 400 manual linear motion manipulators are designed for use with Wentworth Pegasus™ series and Aspect probers. They deliver a highly versatile solution for applications such as direct current (DC), radio frequency (RF) and low level testing.

The PVX 400's small footprint makes it ideal for applications requiring a large number of manipulators or where platen area is at a premium.

A wide range of front ends assemblies and needle holders are available for the PVX 400 manipulators, allowing easy integration with most standard systems.

SPECIFICATIONS

Base footprint	38 x 38 mm
Height	62 mm
Weight	0.4 kg vacuum base, without front ends
Travel	X = 10 mm, Y = 10 mm, Z = 10 mm
Resolution	$1.2 \mu\text{m}/^\circ$
Hold down	Vacuum or magnetic
Micrometer head drive	50 TPI

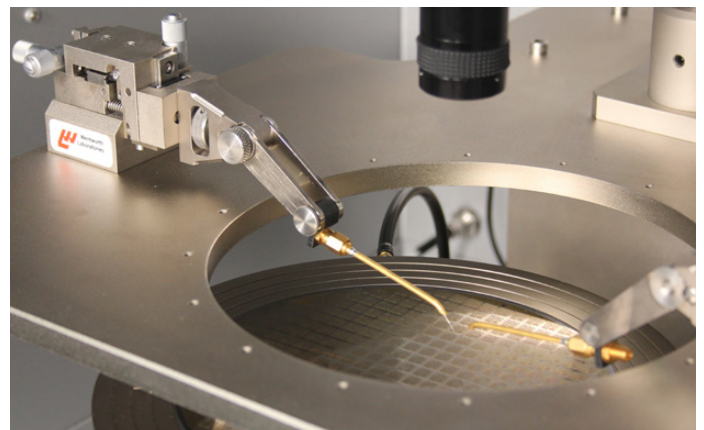

PEGASUS™ PROBE

PROBE WITH INTEGRATED HEIGHT AND EDGE SENSOR

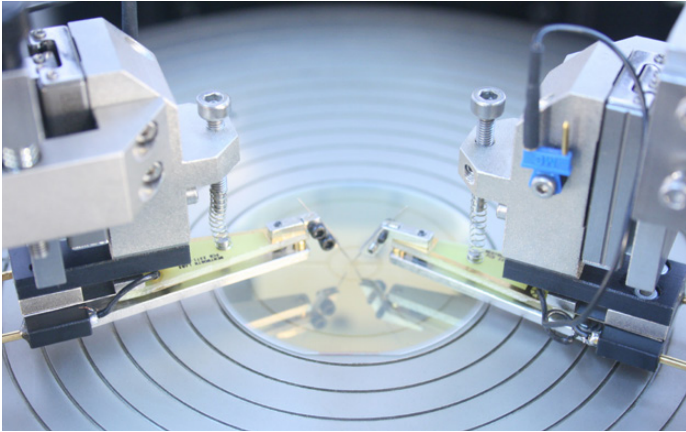

KEY FEATURES

- ✓ Integrated wafer height and edge sensor
- ✓ Variable contact force adjustment
- ✓ Smooth precision positioning
- ✓ Ideal for LED production test
- ✓ Versatile for a wide variety of other applications

DESIGN

The Pegasus™ Probe has an integrated wafer edge and height sensor, combining both functions into one compact unit that quickly secures to a platform designed for multiple Pegasus™ probe units, or a combination of Pegasus™ probes and inkers. This makes it the ideal solution for light-emitting diode (LED) production test, replacing device-specific probe cards while enabling high throughput, along with full on-site or delayed inking capabilities.

DESIGN FLEXIBILITY

The Pegasus™ technology enables location and coordinate data to be rapidly acquired. Three fine-pitched controls control the radial, tangential and height adjustment of the Pegasus™ Probe. The probe head can be removed in situ to enable simple probe needle replacement, without the need for adhesives or special tools.

Adjustable probes are easily positioned for correct pad spacing, or for different spacing between pads and different device sizes. The sensor function allows for the probing of partial wafers, as well as wafers that are not perfectly flat, ensuring a good quality scrub mark of consistent size regardless of wafer height deviation.

APPLICATIONS

The Pegasus™ Probe is designed for a wide range of applications and provides the ideal solution for LED production test. It produces small probe marks, an important advantage when probing for known good die (KGD). Variable contact force adjustment makes it easy to obtain the desired probe mark and throughput.

SPECIFICATIONS

Height	35 mm above platform
Depth	22 mm below platform
Radial adjustment	± 6 mm coarse, ± 5 mm fine
Tangential adjustment	± 5 mm
Probe needle size	0.5 mm (0.020") diameter
Probe force	≥ 5 g
Probe angle	60° to substrate orientation
Max. voltage	2 kV in normal operating position
Probers	Pegasus™ S200/S300 series. Consult us for custom applications.

PVX 400/500 DIMENSIONS

PVX 400

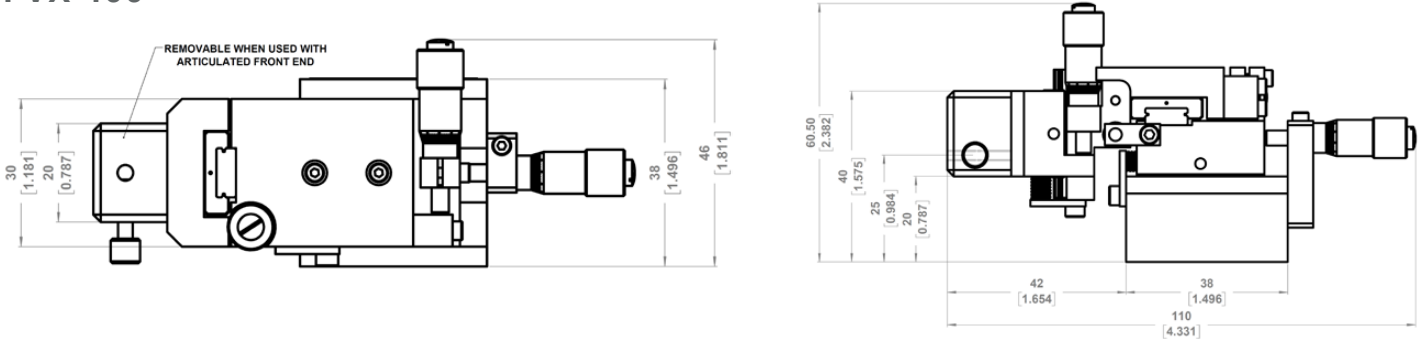

PVX 500 - 100 TPI

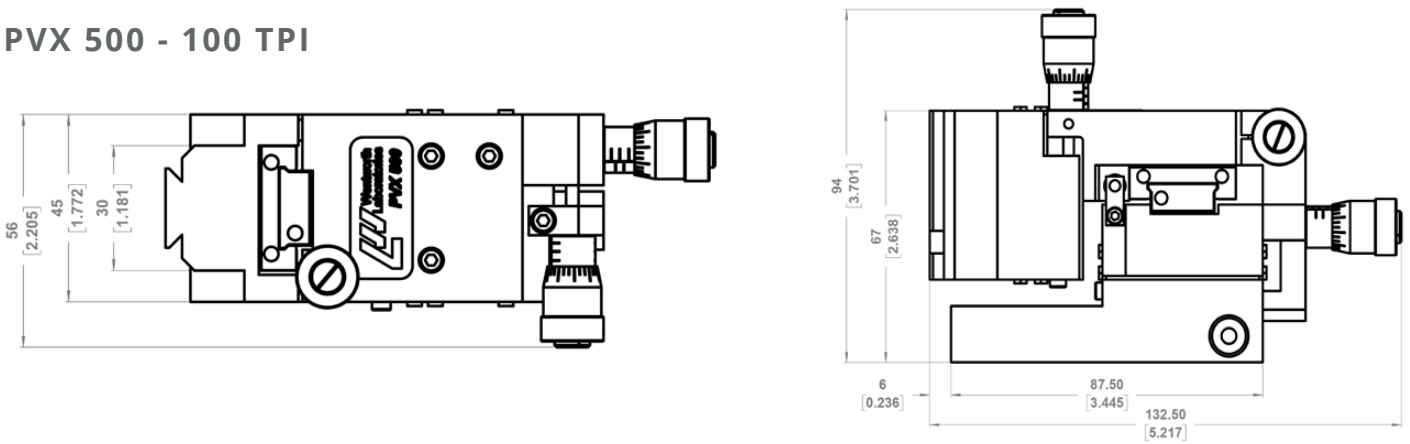

PVX 500 - 200 TPI

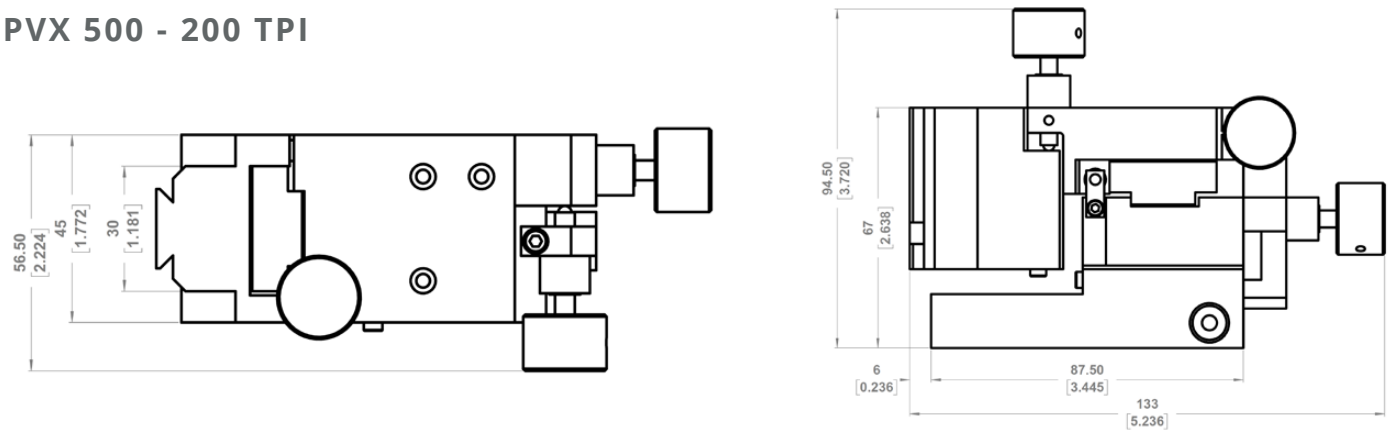

PVX 500 - 200 TPI, REAR ADJUST

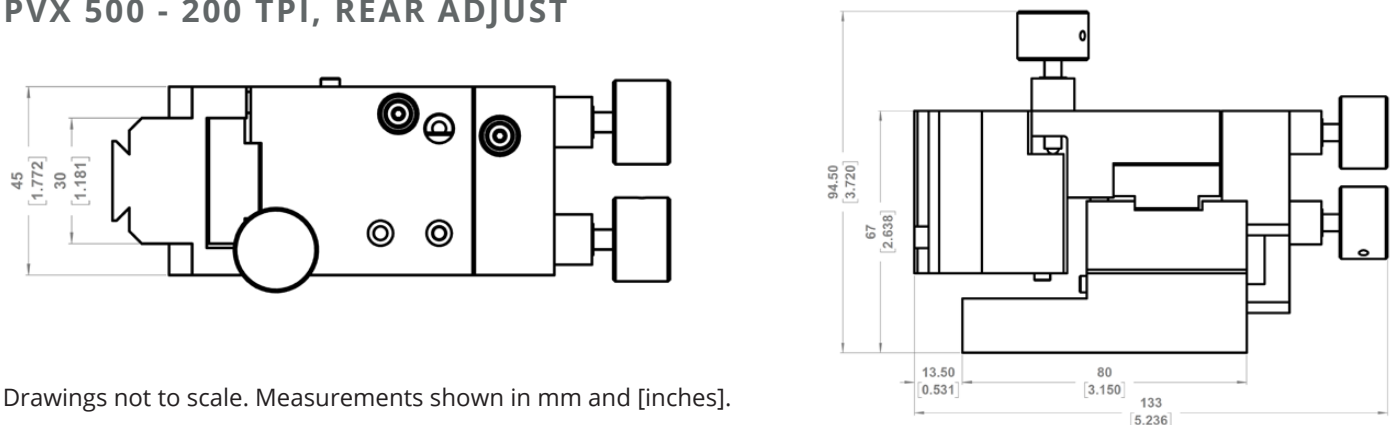

Drawings not to scale. Measurements shown in mm and [inches].

FRONT ENDS & PROBE HOLDERS

LONG NOSE, ARTICULATED LONG ARM
5-000-4721

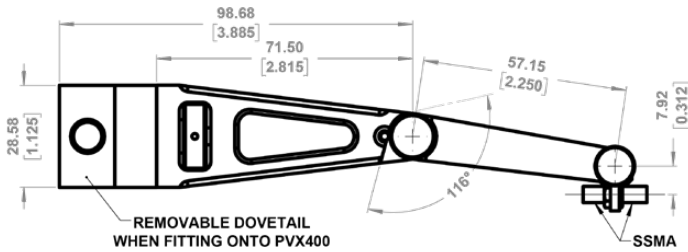

MICROWAVE ADJUSTABLE ARM
2026-96009

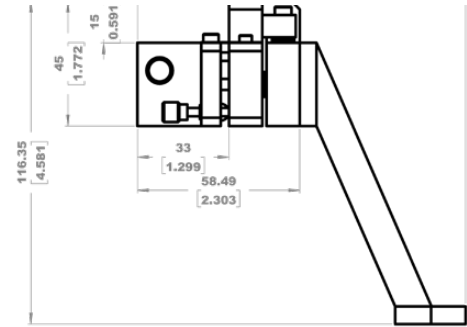

LONG NOSE, ARTICULATED SHORT ARM
5-000-4710

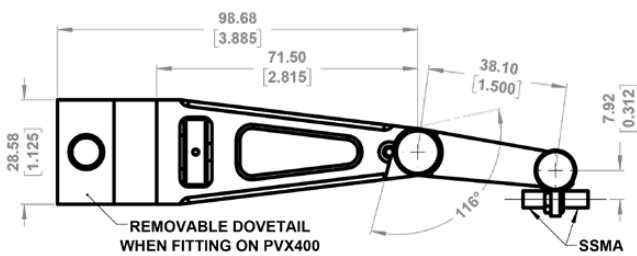

HC/HV PROBE HOLDER
2059-94909

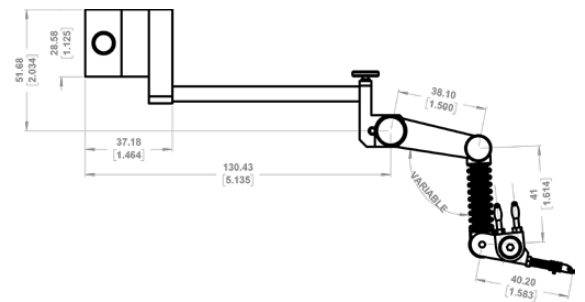

SHORT NOSE, ARTICULATED LONG ARM
5-000-4722

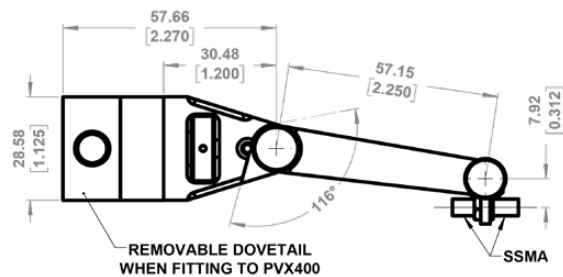

COAX NEEDLE HOLDER
for 0.010" diameter shank needles
5-000-4714

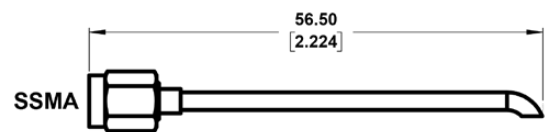

SHORT NOSE, ARTICULATED SHORT ARM
5-000-4711

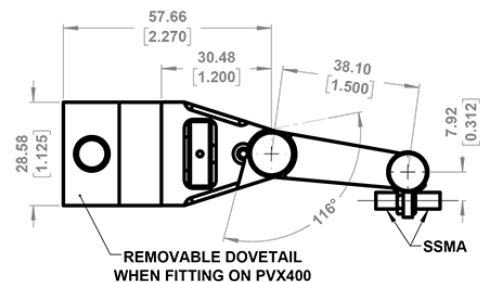

SPRING CLAMP NEEDLE HOLDER
for 0.020" diameter shank needles
5-000-4717

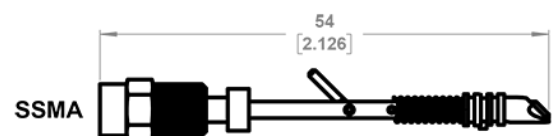

Drawings not to scale. Measurements shown in mm and [inches].

FRONT ENDS, PROBE HOLDERS & CABLES

ACCESSORIES

		Compatible with		
		CAP	PVX 500	PVX 400
P/N 5-000-4711	Short nose articulated short arm front end	✓	✓	✓*
P/N 5-000-4722	Short nose articulated long arm front end	✓	✓	✓*
P/N 5-000-4710	Long nose articulated short arm front end	✓	✓	✓*
P/N 5-000-4721	Long nose articulated long arm front end	✓	✓	✓*
P/N 5-000-6401	Wire form front end includes DC cable 1-040-0076 (tip plug to eyelet) - 60 cm			✓
P/N 5-000-3711	Wire form front end includes DC cable 1-040-0060 (tip plug to SP10 pin) - 60 cm			✓
P/N 2026-96009	Microwave north/south/east/west adjustable arm	✓	✓	
P/N 2026-96509	Articulated front end for Keithley multi-measurement cable set-up	✓	✓	
P/N 5-000-4714	Coax needle holder for 0.010" diameter shank needles	✓	✓	✓
P/N 5-000-4717	Spring clamp needle holder for 0.020" diameter shank needles	✓	✓	✓
P/N 2026-96309	Assembly: Long nose wire front end		✓	
P/N 2059-94909	High current/high voltage probe holder	✓	✓	
Example cables				
P/N 4000-09016	Cable: SSMA to BNC			
P/N 2388-92809	Cable: Triax to BNC			
P/N 4000-09999	Cable: Keithley multi-measurement cables MMPC-W			

“ Contact us for a full list of standard and bespoke cables available.

*For magnetic PVX 400 only. Dovetail must be removed to allow fitting of the front end.
All specifications are subject to change without notice.

ABOUT WENTWORTH LABORATORIES

With over 50 years' experience in wafer probing technology, our solutions are the number one choice for many leading-edge wafer test applications across the globe.

With the support of a world-wide network of representatives, we enable our customers to fulfil even the most challenging wafer probing goals, maximizing their productivity and reducing costs.

Wentworth Laboratories Ltd
1 Gosforth Close, Sandy
Bedfordshire SG19 1RB
United Kingdom
Tel: +44 1767 681221
Email: info@wentworthlabs.com

Wentworth Laboratories, Inc
1087 Federal Road, Unit 4
Brookfield, Connecticut 06804
United States
Tel: +1 203 775 0448
Email: info@wentworthlabs.com



v 03/20

