

XRD 1622 AP3

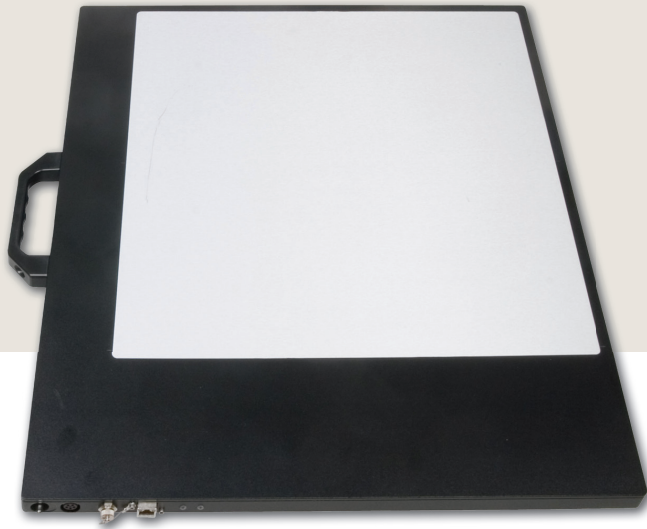

Flat Panel X-ray Detectors

Features and Benefits

- Radiation-hardened for harsh environments
- 200 μm pixel pitch
- Up to 65,536 gray levels
- X-ray energies from 20 kV – 15 MV
- Selectable gain settings
- Gigabit Ethernet interface

Applications¹

- Radiography, Radiosurgery & Proton Therapy
- Industrial Non Destructive Testing & Evaluation
- Veterinary
- Life & Physical Science

Superior Image Quality High Dynamic Range

Overview

The PerkinElmer XRD 1622 AP3 Flat Panel X-ray Detector (FPD) is a member of the PerkinElmer family of 16-inch (41 cm) field of view amorphous silicon (a-Si) X-ray FPDs.

The PerkinElmer XRD 1622 AP3 offers over 87 dB of dynamic range and frame rates up to 4 fps via multiple read-out modes. It supports a broad range of energy levels from 20 kV–15 MV and is available with several shielding options.

Rapid system integration is accomplished via Gigabit Ethernet data communication, integrated trigger and X-ray synchronization circuitry, and a comprehensive software library for image acquisition and processing.

The wide energy range, variable frame rates and shielding options allow the PerkinElmer XRD 1622 AP3 to meet the component requirements of applications¹ such as industrial non destructive testing, radiation therapy for cancer treatment, as well as veterinary and life and physical science.

We have over 20 years of experience partnering with OEMs integrating FPDs into demanding X-ray applications and can customize our product to meet your specific requirements. Let our digital imaging expertise work for you.

XRD 1622 AP3

Sensor			
Panel	Single substrate amorphous silicon active TFT/diode array		
Scintillator	Direct deposition CsI:Tl		
Pixel Matrix	2048 × 2048 @ 200 µm pitch		
Electronics			
Amplifiers	16 × 128 channel custom low noise ASICs with 6 user selectable gain settings		
ADC	16 bit		
Read-out Mode			
	Matrix Pixel (µm ²) fps		
Square	2048 × 2048	200 × 200	1
	1024 × 1024	400 × 400	4
Rectangular	2048 × 1024	200 × 400	2
Mechanical			
Size	50.0 cm (w) × 56.0 cm (l) × 2.2 cm (h)		
Weight	8.8 kg		
Housing	Aluminum		
Shielding	Integrates with shielding cassette for high energy applications (optional)		
Communications			
Data I/F	Gigabit Ethernet Vision		
X-ray I/F	Integrated X-ray trigger control		
Software	Support for 32 and 64 bit Windows OS		

Imaging Performance	
DQE	67% (0 cy/mm), 53% (1 cy/mm), 36% (2 cy/mm) for RQA5
MTF	63% (1 cy/mm), 31% (2 cy/mm) for RQA5
Lag	< 6% 1 st frame
Dynamic Range	> 87 db
Energy	20 kV – 15 MV
Environmental	
Temperature	10 – 40°C (operating), -10 – 50°C (storage)
Humidity	10 – 90%RH (non-condensing)
Ingress	IP-65 rated (total dust and low pressure water jets protection)
Vibration	IEC/EN 60068-2-6(10-150Hz, 0.5g)
Shock	IEC/EN 60068-2-27(11ms, 2g)
Power	
Supply	90 – 264 VAC, 47 – 63 Hz XRD-LPM Power Supply 40 W 100-240 VAC, 50/60 Hz
Dissipation	32 W
Regulatory	
Standards	UL-60601-1, IEC/EN-60601-1, IEC/EN-60950-1
Regulations	CE, RoHS

1: Unless otherwise specified, PerkinElmer Flat Panel X-ray Detectors are components intended to be integrated into products by X-ray system manufacturers. System manufacturers are responsible for qualifying and validating their products for their intended uses and meeting all applicable regulatory requirements.

Contents in this document are subject to change without notice.

Mechanical Characteristics (Dimensions in mm)

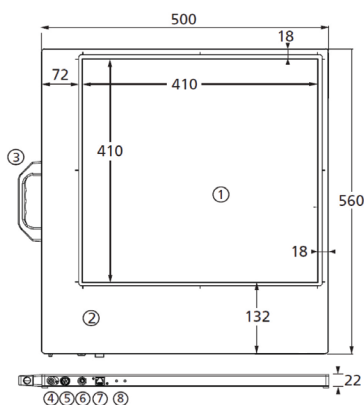

- ① Active sensor area
- ② Electronics area
- ③ Removable handle
- ④ Ground stud
- ⑤ Power connector
- ⑥ X-ray trigger connector
- ⑦ Ethernet connector (RJ45)
- ⑧ Diagnostic LEDs

USA
PerkinElmer, Inc.
2175 Mission College Blvd
Santa Clara, CA 95054 USA
P: +1 408-565-0796
F: +1 408-969-6493
fpd@perkinelmer.com
www.perkinelmer.com

Germany
PerkinElmer
Technologies GmbH & Co. KG
In der Rehbach 22
65396 Walluf Germany
P: +49 6123 971-300
F: +49 6123 971-600
fpd@perkinelmer.com
www.perkinelmer.com

United Kingdom
Dexela Limited
A PerkinElmer Company
Wenlock Business Centre
50-52 Wharf Road
London N1 7EU United Kingdom
P: +44 20 7148 3107
www.dexela.com
fpd@perkinelmer.com
www.perkinelmer.com

China
PerkinElmer, Inc.
No. 1670 Zhangheng Road
Zhangjiang Hi-Tech Park
Shanghai 201203, PRC
P: +86 21 60645611
F: +86 21 60645666
fpd@perkinelmer.com
www.perkinelmer.com



For a complete listing of our global offices, visit www.perkinelmer.com/ContactUs

Copyright ©2012-2013, PerkinElmer, Inc. All rights reserved. PerkinElmer® is a registered trademark of PerkinElmer, Inc. All other trademarks are the property of their respective owners.