

XRD 0822 AO, AP

Industrial Flat Panel Detector

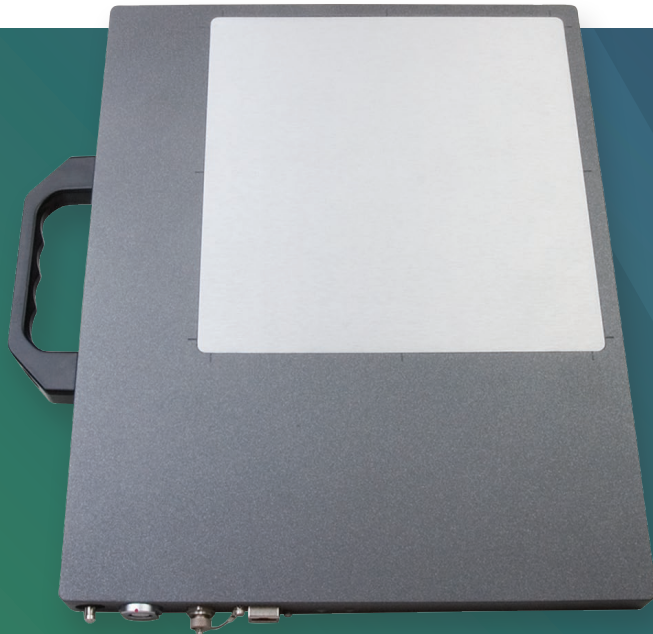

Superior Image Quality High Dynamic Range

XRD 0822 is part of the Varex Imaging's family of 8-inch (20 cm) amorphous silicon Flat Panel Detectors.

OVERVIEW

Varex Imaging XRD 0822 digital Flat Panel X-ray Detector (FPD) is available in two configurations - AO and AP.

XRD 0822 AO provides over 78 dB of dynamic range and frame rates up to 30 frames per second (fps). The enhanced performance XRD 0822 AP offers over 88 dB of dynamic range and frame rates up to 100 fps via several read-out modes. Both detectors support a broad range of energy levels from 20 kV-15 MV and are available with several shielding and scintillator options.

Rapid system integration is accomplished via Gigabit Ethernet data communication, integrated trigger and X-ray synchronization circuitry, and a comprehensive software library for image acquisition and processing.

Wide energy range, variable frame rates and multiple shielding options allow the XRD 0822 to meet demanding component requirements in various applications¹ such as industrial non destructive testing, radiation therapy for cancer treatment, as well as veterinary and life and physical science.

FEATURES AND BENEFITS

- Radiation-hardened for harsh environments
- Real-time imaging
- 200 μ m pixel pitch
- Up to 65,536 gray levels
- X-ray energies from 20 kV to 15 MV
- Selectable gain settings
- Gigabit Ethernet interface

APPLICATIONS¹

- Radiation Therapy, Radiosurgery, & Proton Therapy
- Industrial Non Destructive Testing & Evaluation
- Veterinary
- Life & Physical Science

Technical Specifications

SENSOR

Panel Single substrate amorphous silicon active TFT-diode array
 Scintillator Direct deposition CsI:Tl or various Gd₂O₂S:Tb (GOS) fluorescent screens
 Pixel Matrix 1024 × 1024 @ 200 μm pitch

ELECTRONICS

Amplifiers 8 × 128 channel custom low noise ASICs with 2 (AO) or 6 (AP) user selectable gain settings
 ADC 14-bit (AO), 16-bit (AP)

Read-out Modes	Matrix	Pixel (μm ²)	fps	
			AO	AP
Square	1024 × 1024	200 × 200	15	25
	512 × 512	400 × 400	30	50
Rectangular	1024 × 512	200 × 400	n/a	50
	1024 × 256	200 × 800	n/a	100
Sectional	1024 × 512	200 × 200	n/a	50
	1024 × 256	200 × 200	n/a	100

MECHANICAL

Size 295 mm (w) × 360 mm (l) × 22 mm (h)
 Weight 3.7 kg
 Housing Aluminum
 Shielding Integrates with shielding cassette for high energy applications (optional)

COMMUNICATIONS

Data I/F Gigabit Ethernet Vision
 X-ray I/F Integrated X-ray trigger control
 Software Support for 32 and 64 bit Windows® OS

IMAGING PERFORMANCE

DQE 75% (0 cy/mm), 58% (1 cy/mm), 37% (2 cy/mm) for RQA5 with CsI
 MTF 67% (1 cy/mm), 33% (2 cy/mm) with CsI
 Lag < 8% 1st frame
 Dynamic Range > 78 dB (AO), > 88 dB (AP)
 Energy 20 kV – 15 MV

ENVIRONMENTAL

Temperature 10 – 40°C (operating), -10 – 50°C (storage)
 Humidity 10 – 90% RH (non-condensing)
 Ingress IP-65 rated (total dust and low pressure water jets protection)
 Vibration IEC/EN 60068-2-6(10-150 Hz, 0.5 g)
 Shock IEC/EN 60068-2-27(11 ms, 2 g)

POWER

Supply 100 – 240 VAC, 50/60 Hz
 XRD-EPS Power Supply 215 W
 Dissipation 25 W

REGULATORY

Standards UL-60601-1, IEC/EN-60601-1, IEC/EN-60950-1
 Regulations CE, RoHS

¹ Unless otherwise specified, Varex Imaging Flat Panel X-ray Detectors are components intended to be integrated into products by X-ray system manufacturers. System manufacturers are responsible for qualifying and validating their products for their intended uses and meeting all applicable regulatory requirements.

Contents in this document are subject to change without notice.

MECHANICAL CHARACTERISTICS

(Dimensions in mm)

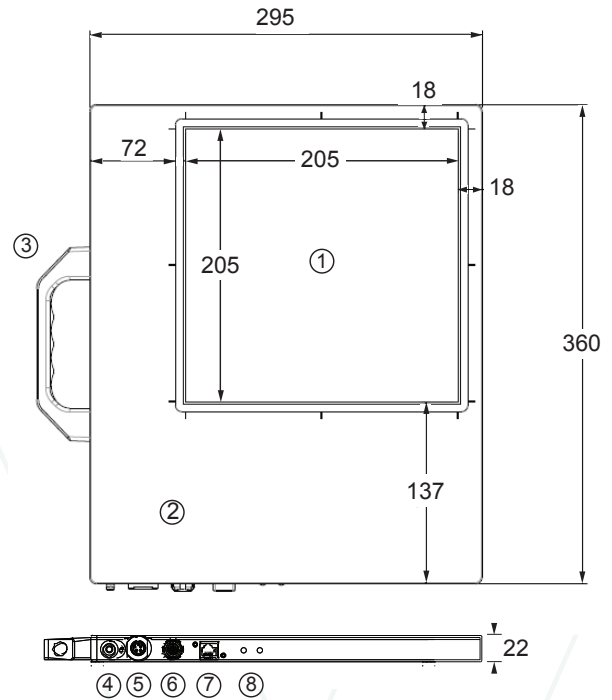

- ① Active sensor area
- ② Electronics area
- ③ Removable handle
- ④ Ground stud
- ⑤ Power connector
- ⑥ X-ray trigger connector
- ⑦ Ethernet connector (RJ45)
- ⑧ Diagnostic LEDs

Varex Imaging Corporation

USA

HEADQUARTERS
 Salt Lake City, UT
 P: +1-801-972-5000

Santa Clara, CA
 P: +1-844-726-8228

For a complete listing of our global offices, visit www.vareximaging.com

Germany

Walluf
 P: +49-6123-971-300

United Kingdom

London
 P: +44-20-7148-3107

China

Wuxi
 P: +86 510 8592-9201

©2017 Varex Imaging Corporation. All Rights reserved. Production of any of the material contained herein in any format or media without the express written permission of Varex Imaging Corporation is prohibited.