

# SN75ALS162

## OCTAL GENERAL-PURPOSE INTERFACE BUS TRANSCEIVER

SLLS020C – JUNE 1986 – REVISED MAY 1995

- Meets IEEE Standard 488-1978 (GPIB)
- 8-Channel Bidirectional Transceiver
- Designed to Implement Control Bus Interface
- Designed for Multicontrollers
- High-Speed Advanced Low-Power Schottky Circuitry
- Low-Power Dissipation . . . 46 mW Max per Channel
- Fast Propagation Times . . . 20 ns Max
- High-Impedance PNP Inputs
- Receiver Hysteresis . . . 650 mV Typ
- Bus-Terminating Resistors Provided on Driver Outputs
- No Loading of Bus When Device Is Powered Down ( $V_{CC} = 0$ )
- Power-Up/Power-Down Protection (Glitch Free)

### description

The SN75ALS162 eight-channel general-purpose interface bus (GPIB) transceiver is a monolithic, high-speed, advanced low-power Schottky process device designed to provide the bus-management and data-transfer signals between operating units of a multiple-controller instrumentation system. When combined with the SN75ALS160 octal bus transceiver, the SN75ALS162 provides the complete 16-wire interface for the IEEE 488 bus.

The SN75ALS162 features eight driver-receiver pairs connected in a front-to-back configuration to form input/output (I/O) ports at both the bus and terminal sides. The direction of data through these driver-receiver pairs is determined by the DC, TE, and SC enable signals. The SC input allows the REN and IFC transceivers to be controlled independently.

The driver outputs (GPIB I/O ports) feature active bus-terminating resistor circuits designed to provide a high impedance to the bus when  $V_{CC} = 0$ . The drivers are designed to handle loads up to 48 mA of sink current. Each receiver features pnp transistor inputs for high input impedance and hysteresis of 400 mV minimum for increased noise immunity. All receivers have 3-state outputs to present a high impedance to the terminal when disabled.

The SN75ALS162 is characterized for operation from 0°C to 70°C.

**DW PACKAGE**  
(TOP VIEW)

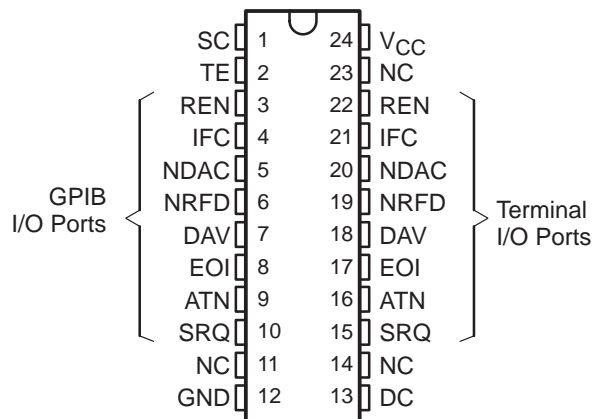

**N PACKAGE**  
(TOP VIEW)

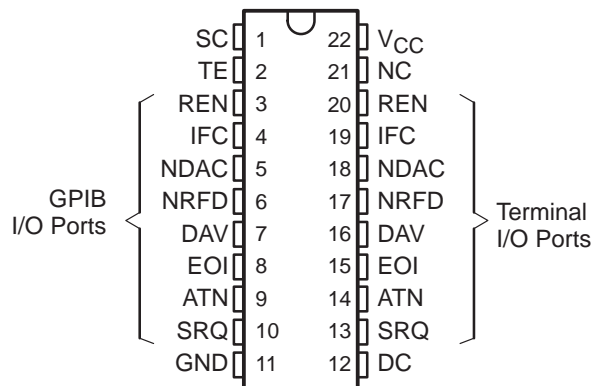

NC—No internal connection



Please be aware that an important notice concerning availability, standard warranty, and use in critical applications of Texas Instruments semiconductor products and disclaimers thereto appears at the end of this data sheet.

PRODUCTION DATA information is current as of publication date. Products conform to specifications per the terms of Texas Instruments standard warranty. Production processing does not necessarily include testing of all parameters.

**TEXAS  
INSTRUMENTS**

POST OFFICE BOX 655303 • DALLAS, TEXAS 75265

Copyright © 1995, Texas Instruments Incorporated

# SN75ALS162 OCTAL GENERAL-PURPOSE INTERFACE BUS TRANSCEIVER

SLLS020C – JUNE 1986 – REVISED MAY 1995

RECEIVE/TRANSMIT FUNCTION TABLE

CONTROLS				BUS-MANAGEMENT CHANNELS				DATA-TRANSFER CHANNELS			
SC	DC	TE	ATN†	ATN† (controlled by DC)	SRQ	REN (controlled by SC)	IFC	EOI	DAV	NDAC	NRFD (controlled by TE)
	H	H	H	R	T			T	T	R	R
	H	H	L					R			
	L	L	H	T	R			R	R	T	T
	L	L	L					T			
	H	L	X	R	T			R	R	T	T
	L	H	X	T	R			T	T	R	R
H						T	T				
L						R	R				

H = high level, L = low level, R = receive, T = transmit, X = irrelevant

Direction of data transmission is from the terminal side to the bus side, and the direction of data receiving is from the bus side to the terminal side.

Data transfer is noninverting in both directions.

† ATN is a normal transceiver channel that functions additionally as an internal direction control or talk enable for EOI whenever the DC and TE inputs are in the same state. When DC and TE are in opposite states, the ATN channel functions as an independent transceiver only.

CHANNEL IDENTIFICATION TABLE

NAME	IDENTITY	CLASS
DC	Direction Control	Control
TE	Talk Enable	
SC	System Control	
ATN	Attention	Bus Management
SRQ	Service Request	
REN	Remote Enable	
IFC	Interface Clear	
EOI	End or Identify	
DAV	Data Valid	Data Transfer
NDAC	No Data Accepted	
NRFD	Not Ready for Data	

# SN75ALS162 OCTAL GENERAL-PURPOSE INTERFACE BUS TRANSCEIVER

SLLS020C – JUNE 1986 – REVISED MAY 1995

logic symbol†

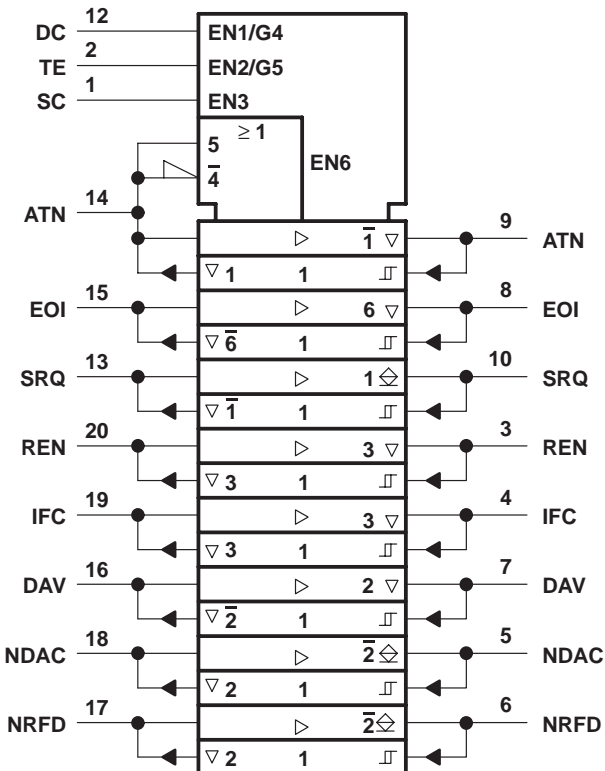

† This symbol is in accordance with ANSI/IEEE Std 91-1984 and IEC Publication 617-12.

▽ Designates 3-state outputs

◇ Designates passive-pullup outputs

Pin numbers shown are for the N package.

logic diagram (positive logic)

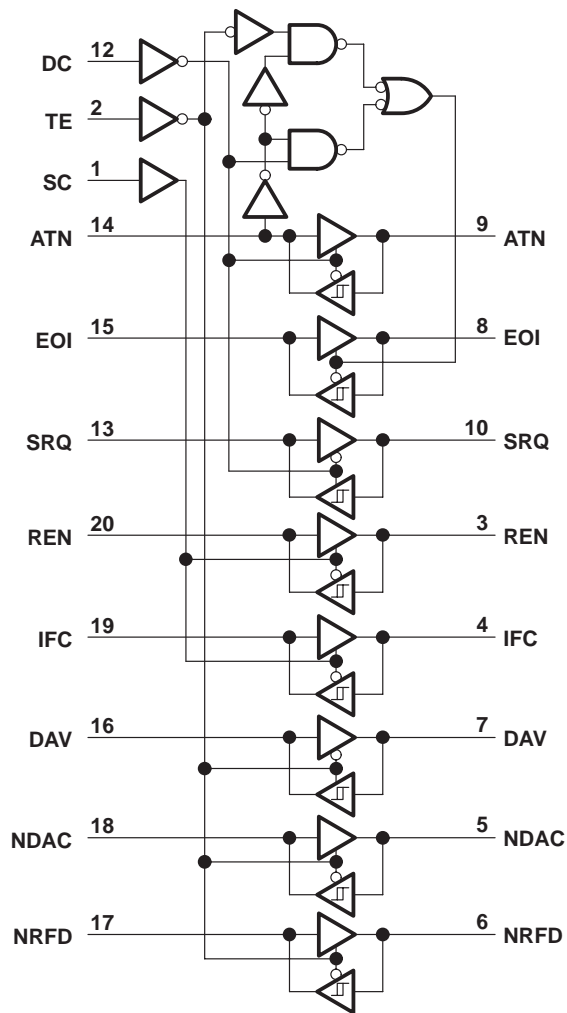

# SN75ALS162 OCTAL GENERAL-PURPOSE INTERFACE BUS TRANSCEIVER

SLLS020C – JUNE 1986 – REVISED MAY 1995

## schematics of inputs and outputs

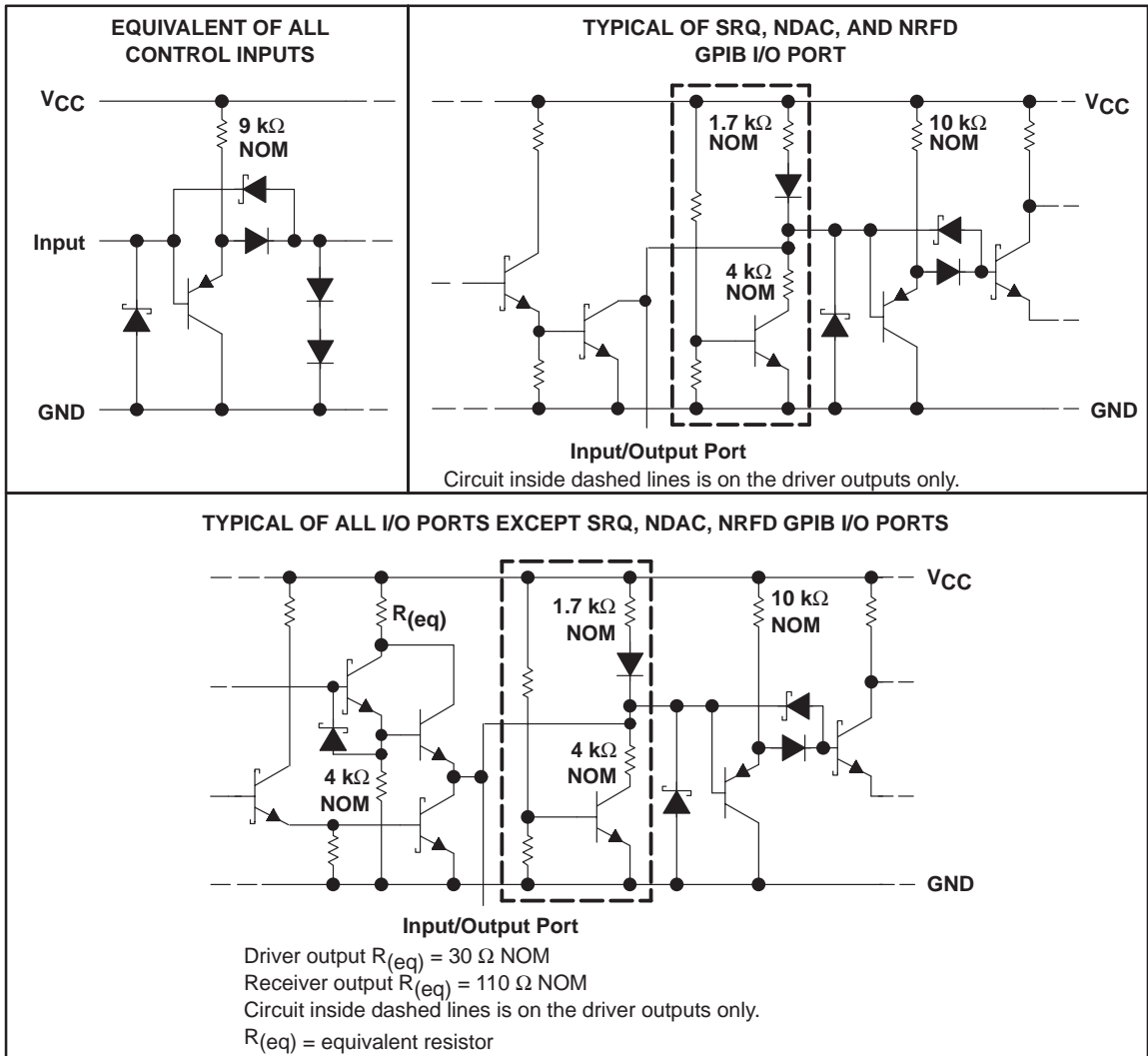

## absolute maximum ratings over operating free-air temperature range (unless otherwise noted)†

Supply voltage, $V_{CC}$ (see Note 1)	7 V
Input voltage, $V_I$	5.5 V
Low-level driver output current, $I_{OL}$	100 mA
Continuous total dissipation	See Dissipation Rating Table
Operating free-air temperature range, $T_A$	0°C to 70°C
Storage temperature range, $T_{stg}$	-65°C to 150°C
Lead temperature 1,6 mm (1/16 inch) from the case for 10 seconds	260°C

† Stresses beyond those listed under "absolute maximum ratings" may cause permanent damage to the device. These are stress ratings only, and functional operation of the device at these or any other conditions beyond those indicated under "recommended operating conditions" is not implied. Exposure to absolute-maximum-rated conditions for extended periods may affect device reliability.

NOTES: 1. All voltage values are with respect to network ground terminal.

# SN75ALS162

## OCTAL GENERAL-PURPOSE INTERFACE BUS TRANSCEIVER

SLLS020C – JUNE 1986 – REVISED MAY 1995

**DISSIPATION RATING TABLE**

PACKAGE	$T_A \leq 25^\circ\text{C}$ POWER RATING	DERATING FACTOR	$T_A = 70^\circ\text{C}$ POWER RATING
DW	1350 mW	10.8 mW/°C	864 mW
N	1700 mW	13.6 mW/°C	1088 mW

### recommended operating conditions

		MIN	NOM	MAX	UNIT
Supply voltage, $V_{CC}$		4.75	5	5.25	V
High-level input voltage, $V_{IH}$		2			V
Low level input voltage, $V_{IL}$				0.8	V
High-level output current, $I_{OH}$	Bus ports with 3-state outputs			-5.2	mA
	Terminal ports			-800	$\mu\text{A}$
Low-level output current, $I_{OL}$	Bus ports			48	mA
	Terminal ports			16	
Operating free-air temperature, $T_A$		0		70	°C

### electrical characteristics over recommended ranges of supply voltage and operating free-air temperature (unless otherwise noted)

PARAMETER		TEST CONDITIONS		MIN	TYP†	MAX	UNIT		
$V_{IK}$	Input clamp voltage	$I_I = -18 \text{ mA}$		-0.8	-1.5		V		
$V_{hys}$	Hysteresis voltage ( $V_{IT+} - V_{IT-}$ )	Bus		0.4	0.65		V		
$V_{OH}^\ddagger$	High-level output voltage	Terminal	$I_{OH} = -800 \mu\text{A}$	2.7	3.5		V		
		Bus	$I_{OH} = -5.2 \text{ mA}$	2.5	3.3				
$V_{OL}$	Low-level output voltage	Terminal	$I_{OL} = 16 \text{ mA}$		0.3	0.5	V		
		Bus	$I_{OL} = 48 \text{ mA}$		0.35	0.5			
$I_I$	Input current at maximum input voltage	Terminal	$V_I = 5.5 \text{ V}$		0.2	100	$\mu\text{A}$		
$I_{IH}$	High-level input current	Terminal and control inputs	$V_I = 2.7 \text{ V}$		0.1	20	$\mu\text{A}$		
$I_{IL}$	Low-level input current		$V_I = 0.5 \text{ V}$		-10	-100	$\mu\text{A}$		
$V_{I/O(\text{bus})}$	Voltage at bus port	Driver disabled	$I_{I(\text{bus})} = 0$	2.5	3.0	3.7	V		
			$I_{I(\text{bus})} = -12 \text{ mA}$			-1.5			
$I_{I/O(\text{bus})}$	Current into bus port	Power on	Driver disabled	$V_{I(\text{bus})} = -1.5 \text{ V to } 0.4 \text{ V}$	-1.3		mA		
				$V_{I(\text{bus})} = 0.4 \text{ V to } 2.5 \text{ V}$	0			-3.2	
				$V_{I(\text{bus})} = 2.5 \text{ V to } 3.7 \text{ V}$				+2.5	-3.2
				$V_{I(\text{bus})} = 3.7 \text{ V to } 5 \text{ V}$	0			2.5	
				$V_{I(\text{bus})} = 5 \text{ V to } 5.5 \text{ V}$	0.7			2.5	
		Power off	$V_{CC} = 0, V_{I(\text{bus})} = 0 \text{ to } 2.5 \text{ V}$			-40	$\mu\text{A}$		
$I_{OS}$	Short-circuit output current	Terminal		-15	-35	-75	mA		
		Bus		-25	-50	-125			
$I_{CC}$	Supply current	No load, TE, DC, and SC low			55	75	mA		
$C_{I/O(\text{bus})}$	Bus-port capacitance	$V_{CC} = 0 \text{ to } 5 \text{ V}, V_{I/O} = 0 \text{ to } 2 \text{ V}, f = 1 \text{ MHz}$			30		pF		

† All typical values are at  $V_{CC} = 5 \text{ V}, T_A = 25^\circ\text{C}$ .

‡  $V_{OH}$  applies to 3-state outputs only.



# SN75ALS162

## OCTAL GENERAL-PURPOSE INTERFACE BUS TRANSCEIVER

SLLS020C – JUNE 1986 – REVISED MAY 1995

switching characteristics over recommended range of operating free-air temperature,  $V_{CC} = 5\text{ V}$

PARAMETER		FROM (INPUT)	TO (OUTPUT)	TEST CONDITIONS	MIN	TYP†	MAX	UNIT
$t_{PLH}$	Propagation delay time, low- to high-level output	Terminal	Bus	$C_L = 30\text{ pF}$ , See Figure 1	10	20	20	ns
$t_{PHL}$	Propagation delay time, high- to low-level output				12	20		
$t_{PLH}$	Propagation delay time, low- to high-level output	Bus	Terminal	$C_L = 30\text{ pF}$ , See Figure 2	5	10	14	ns
$t_{PHL}$	Propagation delay time, high- to low-level output				7	14		
$t_{PZH}$	Output enable time to high level	TE, DC, or SC	Bus (ATN, EOI, REN, IFC, and DAV)	$C_L = 15\text{ pF}$ , See Figure 3			30	ns
$t_{PHZ}$	Output disable time from high level						20	
$t_{PZL}$	Output enable time to low level						45	
$t_{PLZ}$	Output disable time from low level						20	
$t_{PZH}$	Output enable time to high level	TE, DC, or SC	Terminal	$C_L = 15\text{ pF}$ , See Figure 4			30	ns
$t_{PHZ}$	Output disable time from high level						25	
$t_{PZL}$	Output enable time to low level						30	
$t_{PLZ}$	Output disable time from low level						25	

† All typical values are at  $T_A = 25^\circ\text{C}$ .

### PARAMETER MEASUREMENT INFORMATION

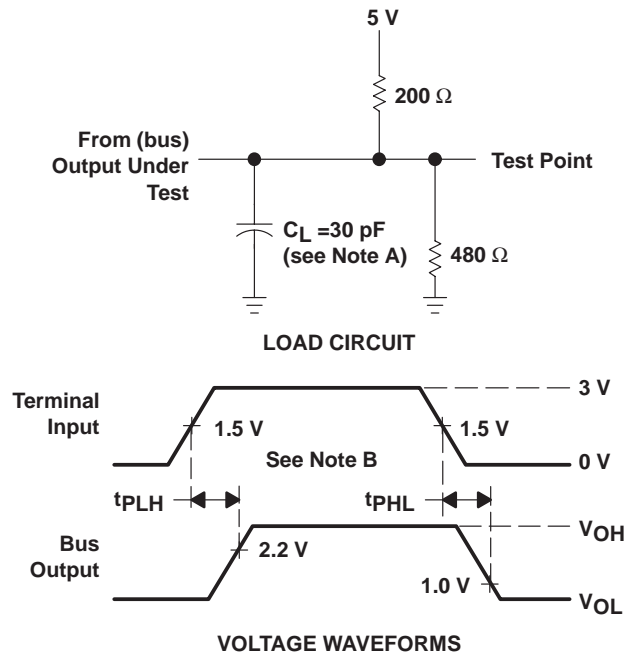

NOTES: A.  $C_L$  includes probe and jig capacitance.

B. The input pulse is supplied by a generator having the following characteristics:  $PRR \leq 1\text{ MHz}$ , 50% duty cycle,  $t_r \leq 6\text{ ns}$ ,  $t_f \leq 6\text{ ns}$ ,  $Z_O = 50\ \Omega$ .

Figure 1. Terminal-to-Bus Load Circuit and Voltage Waveforms

**PARAMETER MEASUREMENT INFORMATION**

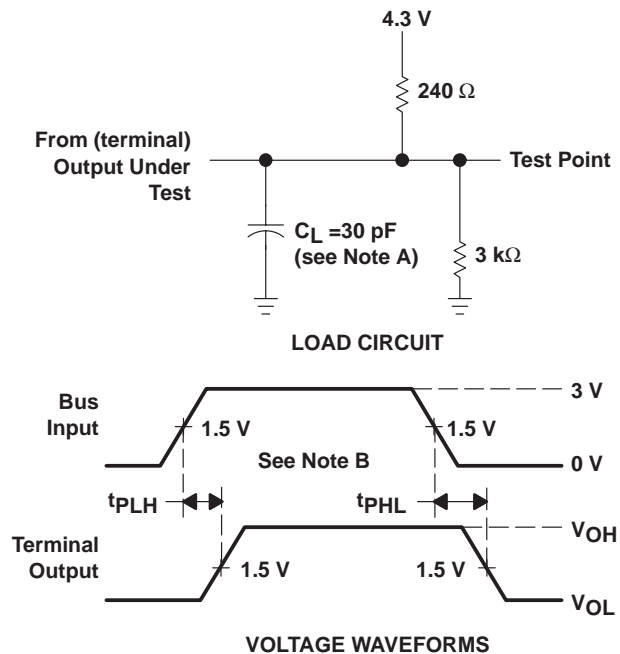

- NOTES: A.  $C_L$  includes probe and jig capacitance.  
 B. The input pulse is supplied by a generator having the following characteristics:  $PRR \leq 1$  MHz, 50% duty cycle,  $t_r \leq 6$  ns,  $t_f \leq 6$  ns,  $Z_O = 50 \Omega$ .

**Figure 2. Bus-to-Terminal Load Circuit and Voltage Waveforms**

# SN75ALS162 OCTAL GENERAL-PURPOSE INTERFACE BUS TRANSCEIVER

SLLS020C – JUNE 1986 – REVISED MAY 1995

## PARAMETER MEASUREMENT INFORMATION

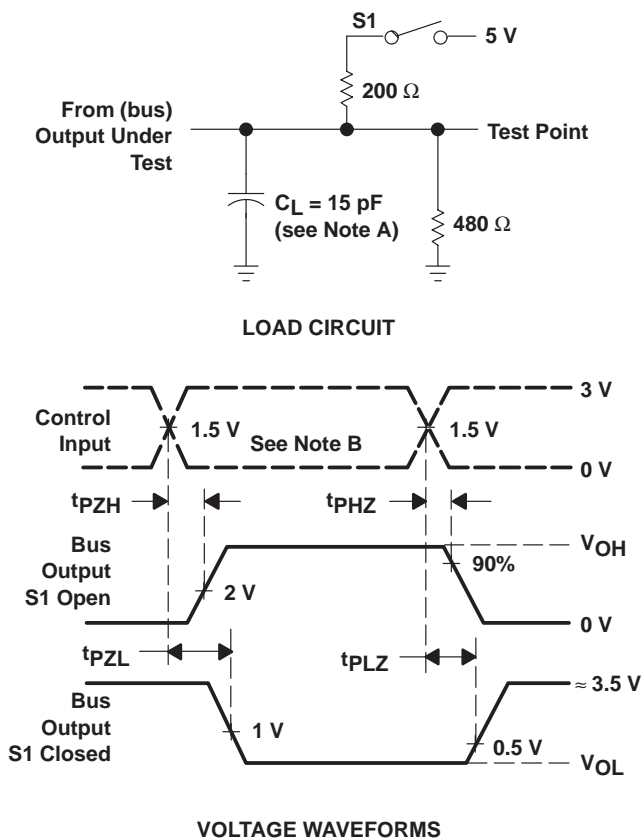

- NOTES: A.  $C_L$  includes probe and jig capacitance.  
 B. The input pulse is supplied by a generator having the following characteristics:  $PRR \leq 1$  MHz, 50% duty cycle,  $t_r \leq 6$  ns,  $t_f \leq 6$  ns,  $Z_O = 50 \Omega$ .

**Figure 3. Bus Load Circuit and Voltage Waveforms**



**PARAMETER MEASUREMENT INFORMATION**

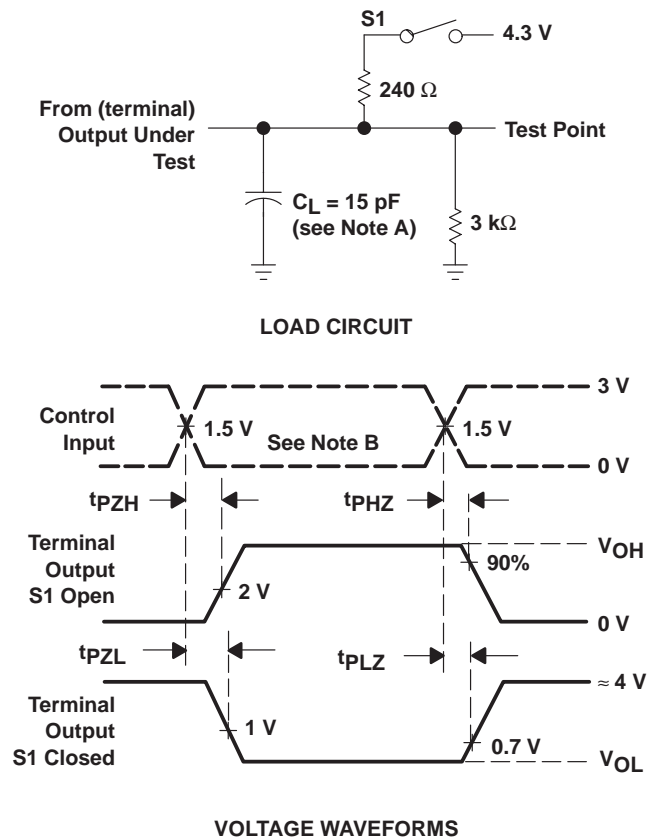

- NOTES: A.  $C_L$  includes probe and jig capacitance.  
 B. The input pulse is supplied by a generator having the following characteristics:  $PRR \leq 1$  MHz, 50% duty cycle,  $t_r \leq 6$  ns,  $t_f \leq 6$  ns,  $Z_O = 50 \Omega$ .

**Figure 4. Terminal Load Circuit and Voltage Waveforms**

# SN75ALS162 OCTAL GENERAL-PURPOSE INTERFACE BUS TRANSCEIVER

SLLS020C – JUNE 1986 – REVISED MAY 1995

## TYPICAL CHARACTERISTICS

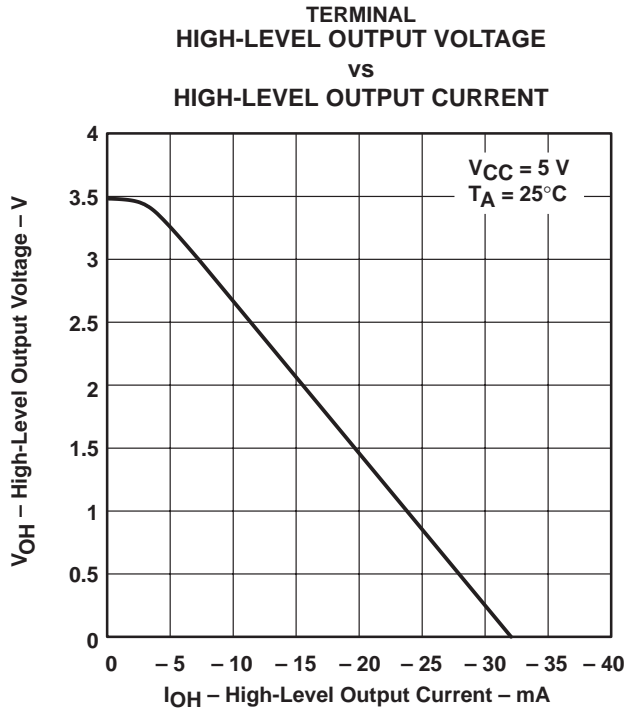

Figure 5

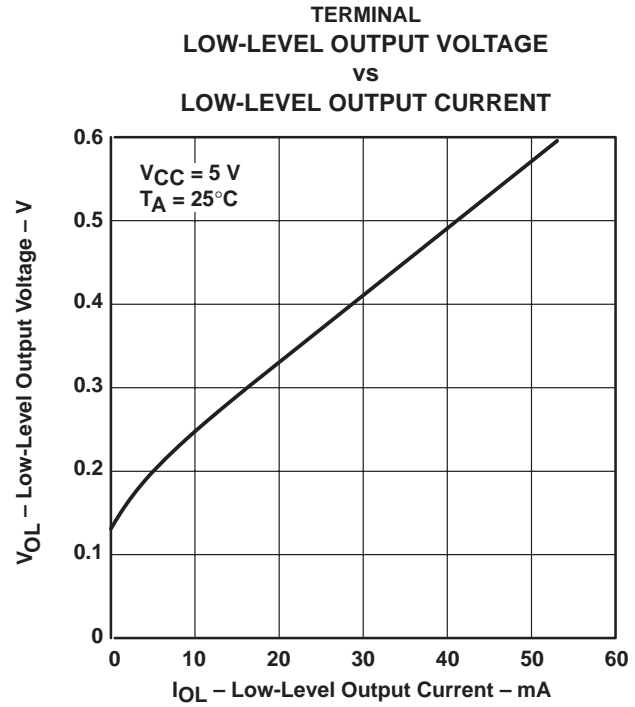

Figure 6

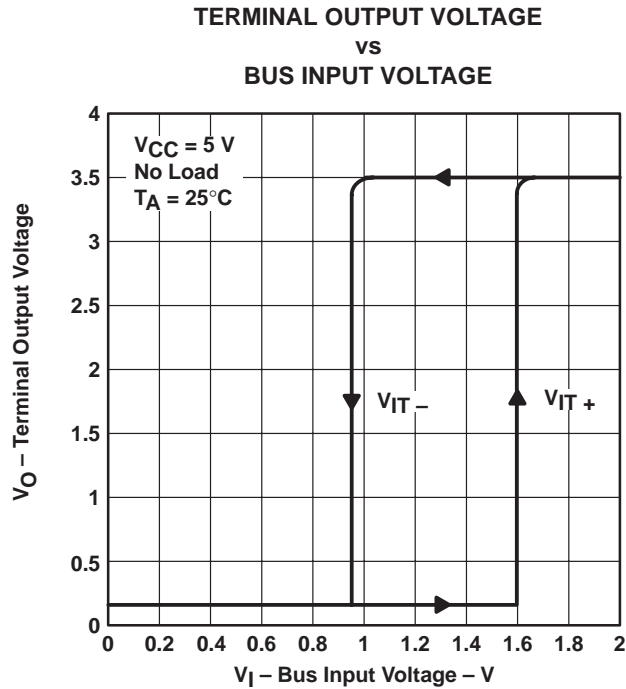

Figure 7

**TYPICAL CHARACTERISTICS**

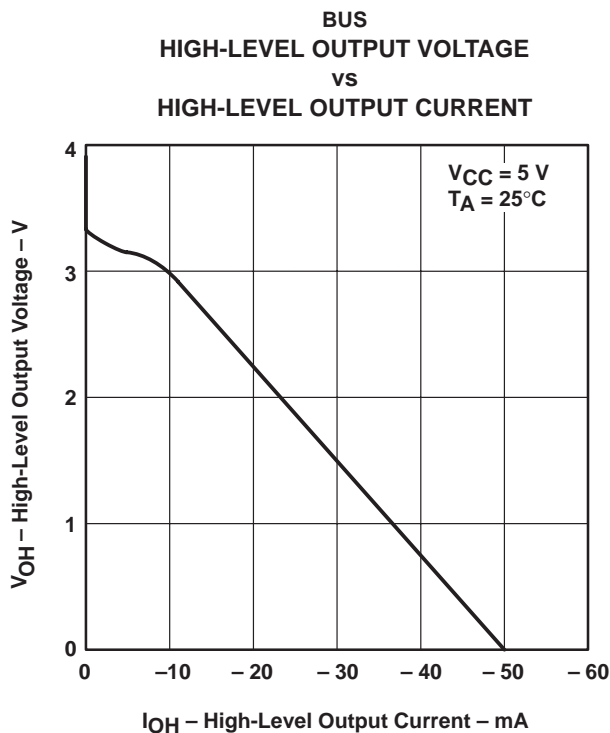

Figure 8

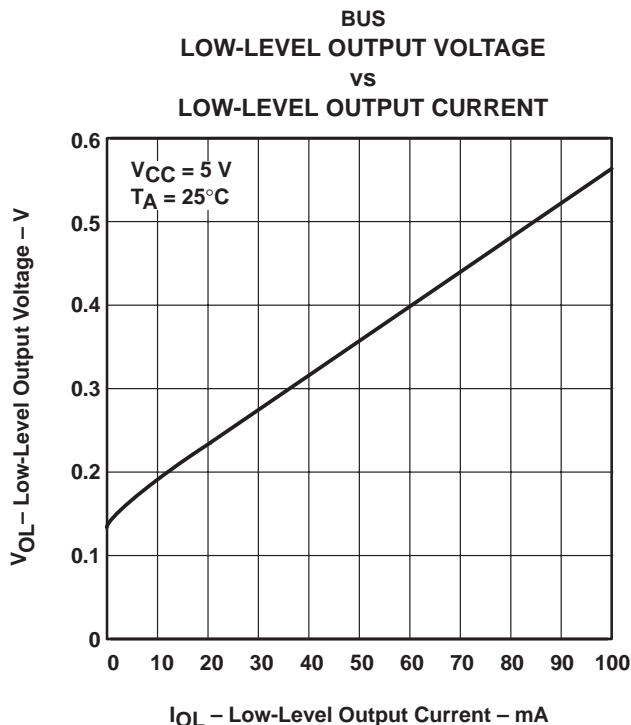

Figure 9

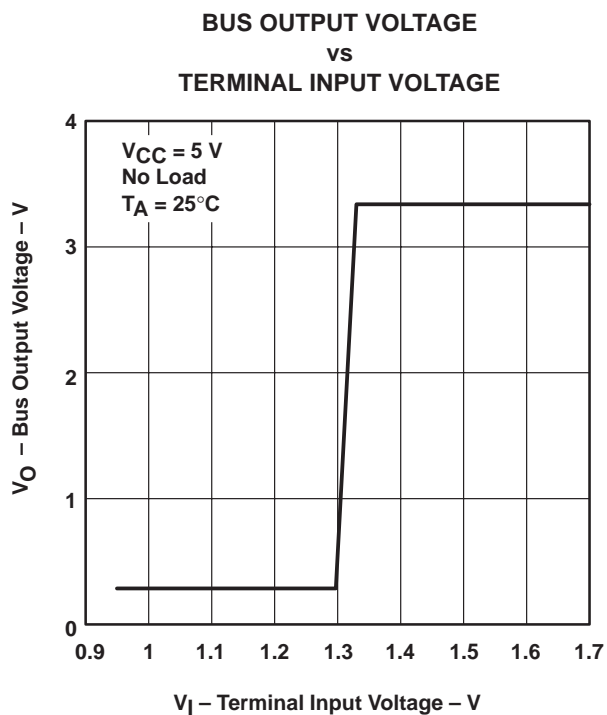

Figure 10

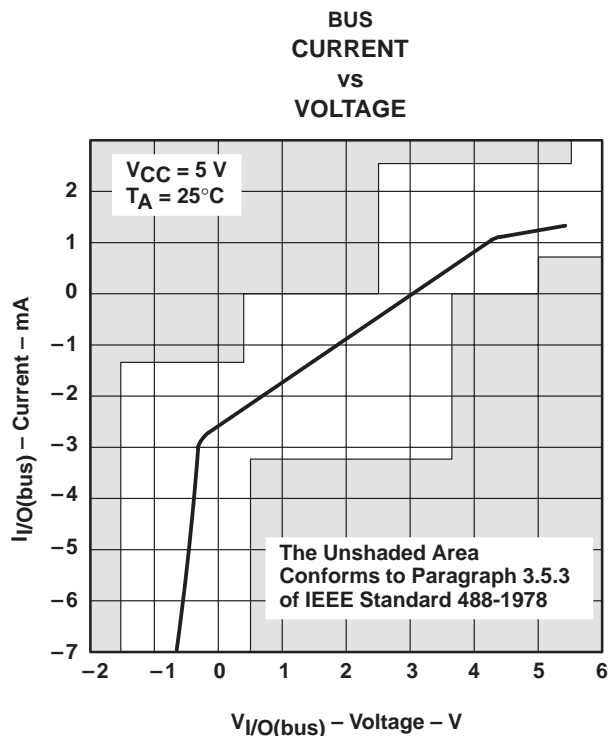

Figure 11

**PACKAGING INFORMATION**

Orderable Device	Status (1)	Package Type	Package Drawing	Pins	Package Qty	Eco Plan (2)	Lead/Ball Finish (6)	MSL Peak Temp (3)	Op Temp (°C)	Device Marking (4/5)	Samples
SN75ALS162DW	ACTIVE	SOIC	DW	24	25	Green (RoHS & no Sb/Br)	CU NIPDAU	Level-1-260C-UNLIM	0 to 70	75ALS162	<a href="#">Samples</a>
SN75ALS162DWE4	ACTIVE	SOIC	DW	24	25	Green (RoHS & no Sb/Br)	CU NIPDAU	Level-1-260C-UNLIM	0 to 70	75ALS162	<a href="#">Samples</a>
SN75ALS162DWG4	ACTIVE	SOIC	DW	24	25	Green (RoHS & no Sb/Br)	CU NIPDAU	Level-1-260C-UNLIM	0 to 70	75ALS162	<a href="#">Samples</a>
SN75ALS162DWR	ACTIVE	SOIC	DW	24	2000	Green (RoHS & no Sb/Br)	CU NIPDAU	Level-1-260C-UNLIM	0 to 70	75ALS162	<a href="#">Samples</a>
SN75ALS162DWRG4	ACTIVE	SOIC	DW	24	2000	Green (RoHS & no Sb/Br)	CU NIPDAU	Level-1-260C-UNLIM	0 to 70	75ALS162	<a href="#">Samples</a>

(1) The marketing status values are defined as follows:

**ACTIVE:** Product device recommended for new designs.

**LIFEBUY:** TI has announced that the device will be discontinued, and a lifetime-buy period is in effect.

**NRND:** Not recommended for new designs. Device is in production to support existing customers, but TI does not recommend using this part in a new design.

**PREVIEW:** Device has been announced but is not in production. Samples may or may not be available.

**OBSOLETE:** TI has discontinued the production of the device.

(2) Eco Plan - The planned eco-friendly classification: Pb-Free (RoHS), Pb-Free (RoHS Exempt), or Green (RoHS & no Sb/Br) - please check <http://www.ti.com/productcontent> for the latest availability information and additional product content details.

**TBD:** The Pb-Free/Green conversion plan has not been defined.

**Pb-Free (RoHS):** TI's terms "Lead-Free" or "Pb-Free" mean semiconductor products that are compatible with the current RoHS requirements for all 6 substances, including the requirement that lead not exceed 0.1% by weight in homogeneous materials. Where designed to be soldered at high temperatures, TI Pb-Free products are suitable for use in specified lead-free processes.

**Pb-Free (RoHS Exempt):** This component has a RoHS exemption for either 1) lead-based flip-chip solder bumps used between the die and package, or 2) lead-based die adhesive used between the die and leadframe. The component is otherwise considered Pb-Free (RoHS compatible) as defined above.

**Green (RoHS & no Sb/Br):** TI defines "Green" to mean Pb-Free (RoHS compatible), and free of Bromine (Br) and Antimony (Sb) based flame retardants (Br or Sb do not exceed 0.1% by weight in homogeneous material)

(3) MSL, Peak Temp. - The Moisture Sensitivity Level rating according to the JEDEC industry standard classifications, and peak solder temperature.

(4) There may be additional marking, which relates to the logo, the lot trace code information, or the environmental category on the device.

(5) Multiple Device Markings will be inside parentheses. Only one Device Marking contained in parentheses and separated by a "~" will appear on a device. If a line is indented then it is a continuation of the previous line and the two combined represent the entire Device Marking for that device.

<sup>(6)</sup> Lead/Ball Finish - Orderable Devices may have multiple material finish options. Finish options are separated by a vertical ruled line. Lead/Ball Finish values may wrap to two lines if the finish value exceeds the maximum column width.

**Important Information and Disclaimer:**The information provided on this page represents TI's knowledge and belief as of the date that it is provided. TI bases its knowledge and belief on information provided by third parties, and makes no representation or warranty as to the accuracy of such information. Efforts are underway to better integrate information from third parties. TI has taken and continues to take reasonable steps to provide representative and accurate information but may not have conducted destructive testing or chemical analysis on incoming materials and chemicals. TI and TI suppliers consider certain information to be proprietary, and thus CAS numbers and other limited information may not be available for release.

In no event shall TI's liability arising out of such information exceed the total purchase price of the TI part(s) at issue in this document sold by TI to Customer on an annual basis.

## TAPE AND REEL INFORMATION



### QUADRANT ASSIGNMENTS FOR PIN 1 ORIENTATION IN TAPE

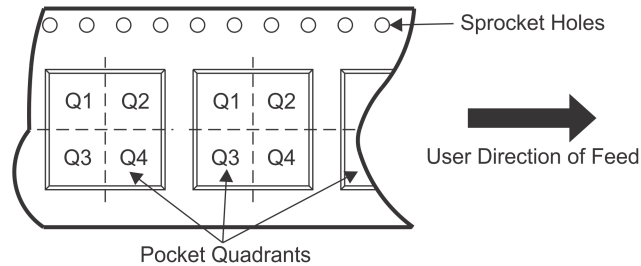

\*All dimensions are nominal

Device	Package Type	Package Drawing	Pins	SPQ	Reel Diameter (mm)	Reel Width W1 (mm)	A0 (mm)	B0 (mm)	K0 (mm)	P1 (mm)	W (mm)	Pin1 Quadrant
SN75ALS162DWR	SOIC	DW	24	2000	330.0	24.4	10.75	15.7	2.7	12.0	24.0	Q1

TAPE AND REEL BOX DIMENSIONS



\*All dimensions are nominal

Device	Package Type	Package Drawing	Pins	SPQ	Length (mm)	Width (mm)	Height (mm)
SN75ALS162DWR	SOIC	DW	24	2000	367.0	367.0	45.0

DW (R-PDSO-G24)

PLASTIC SMALL OUTLINE



- NOTES:
- A. All linear dimensions are in inches (millimeters). Dimensioning and tolerancing per ASME Y14.5M-1994.
  - B. This drawing is subject to change without notice.
  - C. Body dimensions do not include mold flash or protrusion not to exceed 0.006 (0,15).
  - D. Falls within JEDEC MS-013 variation AD.



## IMPORTANT NOTICE

Texas Instruments Incorporated (TI) reserves the right to make corrections, enhancements, improvements and other changes to its semiconductor products and services per JESD46, latest issue, and to discontinue any product or service per JESD48, latest issue. Buyers should obtain the latest relevant information before placing orders and should verify that such information is current and complete.

TI's published terms of sale for semiconductor products (<http://www.ti.com/sc/docs/stdterms.htm>) apply to the sale of packaged integrated circuit products that TI has qualified and released to market. Additional terms may apply to the use or sale of other types of TI products and services.

Reproduction of significant portions of TI information in TI data sheets is permissible only if reproduction is without alteration and is accompanied by all associated warranties, conditions, limitations, and notices. TI is not responsible or liable for such reproduced documentation. Information of third parties may be subject to additional restrictions. Resale of TI products or services with statements different from or beyond the parameters stated by TI for that product or service voids all express and any implied warranties for the associated TI product or service and is an unfair and deceptive business practice. TI is not responsible or liable for any such statements.

Buyers and others who are developing systems that incorporate TI products (collectively, "Designers") understand and agree that Designers remain responsible for using their independent analysis, evaluation and judgment in designing their applications and that Designers have full and exclusive responsibility to assure the safety of Designers' applications and compliance of their applications (and of all TI products used in or for Designers' applications) with all applicable regulations, laws and other applicable requirements. Designer represents that, with respect to their applications, Designer has all the necessary expertise to create and implement safeguards that (1) anticipate dangerous consequences of failures, (2) monitor failures and their consequences, and (3) lessen the likelihood of failures that might cause harm and take appropriate actions. Designer agrees that prior to using or distributing any applications that include TI products, Designer will thoroughly test such applications and the functionality of such TI products as used in such applications.

TI's provision of technical, application or other design advice, quality characterization, reliability data or other services or information, including, but not limited to, reference designs and materials relating to evaluation modules, (collectively, "TI Resources") are intended to assist designers who are developing applications that incorporate TI products; by downloading, accessing or using TI Resources in any way, Designer (individually or, if Designer is acting on behalf of a company, Designer's company) agrees to use any particular TI Resource solely for this purpose and subject to the terms of this Notice.

TI's provision of TI Resources does not expand or otherwise alter TI's applicable published warranties or warranty disclaimers for TI products, and no additional obligations or liabilities arise from TI providing such TI Resources. TI reserves the right to make corrections, enhancements, improvements and other changes to its TI Resources. TI has not conducted any testing other than that specifically described in the published documentation for a particular TI Resource.

Designer is authorized to use, copy and modify any individual TI Resource only in connection with the development of applications that include the TI product(s) identified in such TI Resource. NO OTHER LICENSE, EXPRESS OR IMPLIED, BY ESTOPPEL OR OTHERWISE TO ANY OTHER TI INTELLECTUAL PROPERTY RIGHT, AND NO LICENSE TO ANY TECHNOLOGY OR INTELLECTUAL PROPERTY RIGHT OF TI OR ANY THIRD PARTY IS GRANTED HEREIN, including but not limited to any patent right, copyright, mask work right, or other intellectual property right relating to any combination, machine, or process in which TI products or services are used. Information regarding or referencing third-party products or services does not constitute a license to use such products or services, or a warranty or endorsement thereof. Use of TI Resources may require a license from a third party under the patents or other intellectual property of the third party, or a license from TI under the patents or other intellectual property of TI.

TI RESOURCES ARE PROVIDED "AS IS" AND WITH ALL FAULTS. TI DISCLAIMS ALL OTHER WARRANTIES OR REPRESENTATIONS, EXPRESS OR IMPLIED, REGARDING RESOURCES OR USE THEREOF, INCLUDING BUT NOT LIMITED TO ACCURACY OR COMPLETENESS, TITLE, ANY EPIDEMIC FAILURE WARRANTY AND ANY IMPLIED WARRANTIES OF MERCHANTABILITY, FITNESS FOR A PARTICULAR PURPOSE, AND NON-INFRINGEMENT OF ANY THIRD PARTY INTELLECTUAL PROPERTY RIGHTS. TI SHALL NOT BE LIABLE FOR AND SHALL NOT DEFEND OR INDEMNIFY DESIGNER AGAINST ANY CLAIM, INCLUDING BUT NOT LIMITED TO ANY INFRINGEMENT CLAIM THAT RELATES TO OR IS BASED ON ANY COMBINATION OF PRODUCTS EVEN IF DESCRIBED IN TI RESOURCES OR OTHERWISE. IN NO EVENT SHALL TI BE LIABLE FOR ANY ACTUAL, DIRECT, SPECIAL, COLLATERAL, INDIRECT, PUNITIVE, INCIDENTAL, CONSEQUENTIAL OR EXEMPLARY DAMAGES IN CONNECTION WITH OR ARISING OUT OF TI RESOURCES OR USE THEREOF, AND REGARDLESS OF WHETHER TI HAS BEEN ADVISED OF THE POSSIBILITY OF SUCH DAMAGES.

Unless TI has explicitly designated an individual product as meeting the requirements of a particular industry standard (e.g., ISO/TS 16949 and ISO 26262), TI is not responsible for any failure to meet such industry standard requirements.

Where TI specifically promotes products as facilitating functional safety or as compliant with industry functional safety standards, such products are intended to help enable customers to design and create their own applications that meet applicable functional safety standards and requirements. Using products in an application does not by itself establish any safety features in the application. Designers must ensure compliance with safety-related requirements and standards applicable to their applications. Designer may not use any TI products in life-critical medical equipment unless authorized officers of the parties have executed a special contract specifically governing such use. Life-critical medical equipment is medical equipment where failure of such equipment would cause serious bodily injury or death (e.g., life support, pacemakers, defibrillators, heart pumps, neurostimulators, and implantables). Such equipment includes, without limitation, all medical devices identified by the U.S. Food and Drug Administration as Class III devices and equivalent classifications outside the U.S.

TI may expressly designate certain products as completing a particular qualification (e.g., Q100, Military Grade, or Enhanced Product). Designers agree that it has the necessary expertise to select the product with the appropriate qualification designation for their applications and that proper product selection is at Designers' own risk. Designers are solely responsible for compliance with all legal and regulatory requirements in connection with such selection.

Designer will fully indemnify TI and its representatives against any damages, costs, losses, and/or liabilities arising out of Designer's non-compliance with the terms and provisions of this Notice.