

# OPERATING MANUAL [Xcontrol-E](#)

[spinogy.de](http://spinogy.de)

# Index

## Preamble

<b>01</b>	<b>General remarks</b>	<b>6</b>
	01.1 Notice	6
	01.2 Limitation of liability	6
	01.3 Product name and type designation	6
	01.4 Labeling of Xcontrol-E	6
	01.5 Manufacturer details	7
	01.6 Target group	7
	01.7 Lifecycles of the machine	7
<b>02</b>	<b>Safety instructions</b>	<b>8</b>
	02.1 Contractual use	8
	02.2 Symbols and notes	8
	02.3 Personnel requisition	8
	02.4 Responsibilities and duties of the operator	10
	02.5 Modifications and unauthorized changes	10
	02.6 Special hazard warnings	10
<b>03</b>	<b>Transport, packaging and storage</b>	<b>11</b>
	03.1 Transport	11
	03.2 Packaging	11
	03.3 Storage	11
<b>04</b>	<b>Technical description</b>	<b>12</b>
	04.1 Configuration possibilities and technical data	12
	04.2 Components	14
	04.3 Dimensions	17
<b>05</b>	<b>Installation</b>	<b>18</b>
	05.1 Transport damages check	18
	05.2 Completeness check	18
	05.3 Installation of Xcontrol-E	18
	05.4 Electrical wiring	20
<b>06</b>	<b>Commissioning</b>	<b>25</b>
	06.1 Power-on test	25
	06.2 Commissioning for regular use	25
<b>07</b>	<b>Maintenance</b>	<b>26</b>
	07.1 Maintenance	26
	07.2 Spare parts	26

<b>08</b>	<b>Disassembly and disposal</b>	<b>27</b>
	08.1 Disassembly	27
	08.2 Disposal	27
<b>09</b>	<b>Service and repair</b>	<b>28</b>
	09.1 Service and repair authorized users	28
<b>10</b>	<b>Warranty</b>	<b>29</b>
<b>11</b>	<b>Declaration of installation</b>	<b>30</b>

# Preamble

Dear customer,

Thank you for choosing the spindle equipment Xcontrol-E from SPINOGY.

Along with this equipment for the spindle, you experience a perfectly aligned system.

The single components of the spindles are manufactured with our machines, assembled in Weiterstadt and completed with high-quality purchased parts. So, we can monitor the complete manufacturing process and always ensure a high quality. In order to keep the quality of this product for a long period, please carefully read this operating manual.

SPINOGY is always working on further development of our products. Therefore, deviations may occur with the spindle and the operating manual. We therefore ask you for your understanding, that no claims can be derived from technical data, illustrations or descriptions.

During the development of this equipment, we have always taken care to involve the feedback of our customers. Nevertheless, we always want to improve to be able to respond to requests even more specific. Therefore, we are very grateful for your praise, constructive criticism and suggestions.

Please contact us for any request, questions or wishes about our products or your application case, we are glad to help you. Just use our contact form on our website or contact us via E-Mail: [mail@spinogy.de](mailto:mail@spinogy.de). Of course, we are also available for a personal conversation.

We wish you a successful work.

Marcel Linke, Andreas Schleifer, Dominik Eschenbach and Marc Schmidt-Winterstein  
Managing directors SPINOGY GmbH

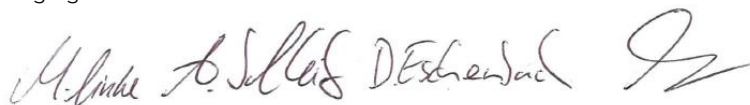

# 01 General remarks

## 01.1 Notice

This operating manual contains important information about handling the product. It has to be read carefully before use. The Xcontrol-E may only be put into operation if the operating manual was understood completely. If there are obscurities, SPINOGY must be contacted. Please follow the instructions of this operating manual. This operating manual must be available for the user at any time and must be replaced in case of loss or impracticality immediately. The obligation to retain applies as long as someone is in possession of the product.

The content of this operating manual is checked for conformity with the described incomplete machine, but deviations and mistakes cannot be excluded. Technical and content-related changes, errors and misprints are reserved.

This operating manual is subject to the copyright law and may not be reproduced, copied or changed in any form, neither all nor part, without the permission of the author. In case of contravention, there is a risk of criminal prosecution. All rights reserved.

## 01.2 Limitation of liability

SPINOGY doesn't assume liability for personal injuries, material damages, damages caused to the device and consequential damages caused by failure to follow this operating manual, improper use of the device, repairs or any other actions done by non-qualified workers (See chapter 2.3 personnel requisition) damages on this unit occur or occurred by using unauthorized non-approved spare parts. Non-compliance of maintenance intervals and maintenance specification of the manufacturer does also lead to limitation of liability. (Please see chapter 7 – maintenance) In addition, it is strictly prohibited to make any unauthorized modifications or technical changes on the device.

## 01.3 Product name

This operating manual is created for the following product:

<b>Product name:</b>	Xcontrol-E, Xcontrol-E DIY
<b>Compatible with spindle:</b>	XP001, XP002, XP003, XP004, XP005, XP006, XP007, XP008, XP021, XP022, XP023, XP024 (as well as all configurations of these spindles)

## 01.4 Labeling of Xcontrol-P



XXXXXX

The Xcontrol-E is labeled with a six-digit serial number. The serial number is located on the upper-left side of the door, pursuant to the following picture.

Using this serial number, all necessary information about the Xcontrol-E can be obtained from SPINOGY at any time.

## 01.5 Manufacturer details

<b>Name:</b>	SPINOGY GmbH
<b>Address:</b>	Brunnenweg 17, 64331 Weiterstadt
<b>E-Mail:</b>	mail@spinogy.de
<b>Phone:</b>	+49 6150 / 970 960
<b>Website:</b>	spinogy.de

## 01.6 Target group

This operating manual is primarily aimed at the following staff:

- Installation staff
- Machine operators
- Maintenance staff

## 01.7 Lifecycles of the machine

The machine processes the following lifecycles:

- Transport
- Assembly
- Operation
- Maintenance
- Disassembly
- Disposal



# 02 Safety instructions

## 02.1 Contractual use

The Xcontrol-E is to be considered as an incomplete machine for the installation into machine tools, covered by the definition of a fixed industrial large tool. Seen in isolation, the Xcontrol-E cannot fulfill any function. The installation has to be done by the manufacturer of the machine tool, as the required skills for professional installation cannot be expected from end users. The Xcontrol-E is to be considered as equipment for a spindle from SPINOGY and is only approved for this purpose.

## 02.2 Symbols and notes

The mentioned symbols in this operating manual shall obviously call the attention of the reader to potential dangers. Those indications or warnings can never be seen as a replacement for correct accident prevention.

	<b>Warning of general hazard</b>
	<b>Warning of dangerous electrical voltage</b>
	<b>Note to avoid material damage</b>

The following signal words are used:

SIGNAL WORD	MEANING
<b>DANGER</b>	Danger with a high risk-level that will result in death or serious injury in case of non-observance
<b>WARNING</b>	Danger with a medium risk-level that will result in death or serious injury in case of non-observance
<b>CAUTION</b>	Danger with a low risk-level that will result in minor or moderate injury in case of non-observance
<b>NOTE</b>	Information that may lead to material damage in case of non-observance

## 02.3 Personnel requisition

### Basic details

Only persons who can be expected to perform their work reliably are permitted as personnel. Persons who have an affected capacity of reaction, e.g. through drugs, alcohol, or medication, are not permitted. Adhere to the valid local regulations relating to age and profession when selecting staff.

	<b>WARNING: Improper use</b> Improper use of the product can lead to considerable personal injuries and material damage. All activities may only be carried out by qualified and trained personnel. If the personnel doesn't have the necessary expertise, the personnel is to be trained and instructed.
---	--



## Qualification

The tasks described in this operating manual represent different personal and professional requirements for the qualifications of the people who are entrusted with these tasks. In this operating manual, the following qualifications are therefore named and required for various fields of activity:

### 1. Professionals

Professionals are, due to their technical training, knowledge and experience and their knowledge of the relevant standards and regulations, able to evaluate and carry out the given tasks. Furthermore, they are able to recognize and avoid potential dangers independently.

### 2. Electricians

Electricians are, due to their technical training, knowledge and experience and their knowledge of the relevant standards and regulations, able to evaluate and carry out the given tasks. Furthermore, they may recognize and avoid potential dangers independently. These electrical engineering works are only allowed, however, to be performed by electricians or under their direction and monitoring.

The technical requirements for electricians are:

- Technical education (electrical engineering)
- Knowledge and experience in the respective field of activity
- Knowledge of the relevant standards
- Evaluation of the work assigned to them
- Recognizing hazards

### 3. Instructed staff

Instructed staff are employees who can behave safely at their workplace. For this purpose, they must be informed about the possible hazards resulting from the tasks assigned to them. In addition, they should recognize the purpose of the occupational safety and health measures and assume personal responsibility for their health-conscious behavior.

For this purpose, they must be informed by the operator about the tasks assigned to them and possible hazards resulting from improper behavior. Corresponding effectiveness-checks by the operator are recommended.

Note: Staff must be regularly and sufficiently instructed by the operator. Further details are regulated in the national occupational safety laws and regulations. For better traceability, the execution of the instruction must be recorded.



#### **WARNING: Unauthorized staff**

Unauthorized staff is unaware of the hazards in their work area. Failure to comply with the personnel requisition can result in serious injury or even death.

### Unauthorized staff

Any person who:

- has not read this operating manual, has not read it completely or has not clearly understood it
  - does not meet the qualification requirements for working with Xcontrol-E
  - has not received instructions from the operator for working with Xcontrol-E
- is considered an unauthorized person.

The following points must therefore be observed in any case:

- Keep unauthorized persons away from the danger and work area
- In case of doubt, talk to persons and direct them away from the danger and work area
- Interrupt the work as long as unauthorized persons are in the danger and work area
- Deny access to unauthorized people

## 02.4 Responsibilities and duties of the operator

The operator himself is assumed to have the necessary qualifications and special expertise in handling machine tools and systems. If the operator does not carry out the necessary work himself, appropriate personnel must be called in for the professional installation, commissioning, maintenance and repair, dismantling/ decommissioning/ disposal!

In addition to the safety instructions in this manual, the country-specific safety measures, occupational health and safety measures and environmental protection regulations etc. valid for the application range of the machine must be observed.

Furthermore, the operator is responsible for the following points:

- Ensuring that the Xcontrol-E is always in a technically perfect condition
- Compliance with maintenance intervals
- Creating of operating instructions
- Creating of hazard assessments
- Training and instruction of authorized staff at regular intervals
- Ensuring that authorized persons using the Xcontrol-E, have carefully read and understood the operating manual
- Equipping staff with the appropriate protective equipment

## 02.5 Modifications and unauthorized changes

Modifications and unauthorized changes at the spindle by the operator are only permitted after consulting SPINOGY. If unauthorized modifications are made, the issued CE declaration of conformity loses its validity and the operator legally becomes the machine manufacturer.

## 02.6 Special hazard warnings



### **DANGER: Electrical voltage**

There is a risk of electric shock, which can lead to serious injury or death. Before working on the Xcontrol-E, switch it off and disconnect it from the electrical network!

# 03 Transport, packaging and storage

## 03.1 Transport

Xcontrol-E is to be transported in a stable packaging with sufficient padding. During the transport, it must be taken care to avoid strong vibrations or shocks, as otherwise damages may occur.

Transport may only be carried out by qualified transport companies or qualified personnel.

The corresponding dimensions and weight specifications of Xcontrol-E can be found in the technical data in chapter 4.

## 03.2 Packaging

The packaging is intended to protect Xcontrol-E until assembly from transport damages and other external influences such as corrosion. The packaging should therefore only be removed shortly before assembly. In addition, the packaging should be kept, if possible, to protect Xcontrol-E in case of storage or to wrap it properly in case of return.

All packaging materials must be disposed at the appropriate collection points.

## 03.3 Storage

The following precautions must be arranged in case of storing Xcontrol-E:

- Xcontrol-E must be stored protected against dust, moisture and other environmental influences
- Mechanical vibrations of Xcontrol-E must be avoided
- The door of Xcontrol-E must be closed
- All openings of Xcontrol-E must be closed
- The following conditions for storage must be observed:
  - o Temperature storage location: +10 to 45 °C
  - o Relative humidity <40%
  - o Do not store outdoor

# 04 Technical description

## 04.1 Configuration possibilities and technical data

The Xcontrol-E is designed for the operation of all SPINOGY spindles and is used for electrical control. It is a plug and play system that includes all electrical components necessary for the operation of a spindle. In addition, the Xcontrol-E can be configured according to your own requirements. A useful basic configuration is provided by SPINOGY and can be found in the following chart.

Equipment no.:	XM039/XM044	XM040/XM045	XM042/XM046	XM043/XM047
<b>Designation</b>	F-M/F-M-DIY	L-M/L-M-DIY	F-ATC/F-ATC-DIY	L-ATC/L-ATC-DIY
<b>Type of spindle</b>	manual or semi-automatic		automatic	
<b>Cooling method spindle</b>	liquid-cooled	air-cooled	liquid-cooled	air-cooled
<b>Frequency inverter</b>	2,2 kW SVC 230 V			
<b>Power supply [V]</b>	230 (1-phase)			
<b>Braking resistor</b>	70 Ω, 600 W / 10 s, 2% ED			
<b>Outputs (customer site)</b>	16 (depending on type of spindle and equipment, not all necessary)			
<b>Inputs (customer site)</b>	11 (depending on type of spindle and equipment, not all necessary)			
<b>Emergency stop circuit</b>	2-pole with switch-off delay time and manual reset			
<b>Electrical cabinet housing</b>	Proper emc-housing			
<b>Protective class</b>	IP20			
<b>Weight [kg]</b>	16			
<b>Cable length motor connection (orange) [m]</b>	5			
<b>Cable length sensor connection (green) [m]</b>	-		5	
<b>Cable length PE – Protective earth (green/yellow) [m]</b>	5			
<b>Cable length power supply [m]</b>	5			
<b>Frequency inverter programming</b>	programmed			
<b>Communication ports</b>	-			
<b>Further interfaces</b>	Integration of Xcontrol-P and Xcool			

There are the following configuration possibilities of the Xcontrol-E:

#### Frequency inverter

Power [kW]	Voltage [V]	Type	Braking resistor
1,5	230 (1-phase)	SVC	70 $\Omega$ , 600 W / 10 s, 2% ED
1,5	230 (1-phase)	HF	70 $\Omega$ , 600 W / 10 s, 2% ED
1,5	400 (3-phase)	SVC	200 $\Omega$ , 600 W / 10 s, 2% ED
1,5	400 (3-phase)	HF	200 $\Omega$ , 600 W / 10 s, 2% ED
2,2	230 (1-phase)	SVC	70 $\Omega$ , 600 W / 10 s, 2% ED
2,2	230 (1-phase)	HF	70 $\Omega$ , 600 W / 10 s, 2% ED
2,2	400 (3-phase)	SVC	200 $\Omega$ , 600 W / 10 s, 2% ED
2,2	400 (3-phase)	HF	200 $\Omega$ , 600 W / 10 s, 2% ED

#### Cable length

Motor connection [m]	Sensor connection [m]	PE-Protective earth [m]	Network connection [m]
Without	Without	2	Without
2	2	5	5
5	5	8	
8	8		
11	11		
14	14		

#### Further configuration possibilities

Communication ports	Programming frequency inverter	Kundenspezifisch
Without	Without	Without
RJ45	Already programmed	Special configurations possible after consulting SPINOXY
USB		
Profibus		
Profinet		

# 04.2 Components

The following picture shows the main components of the Xcontrol-E.

## View door

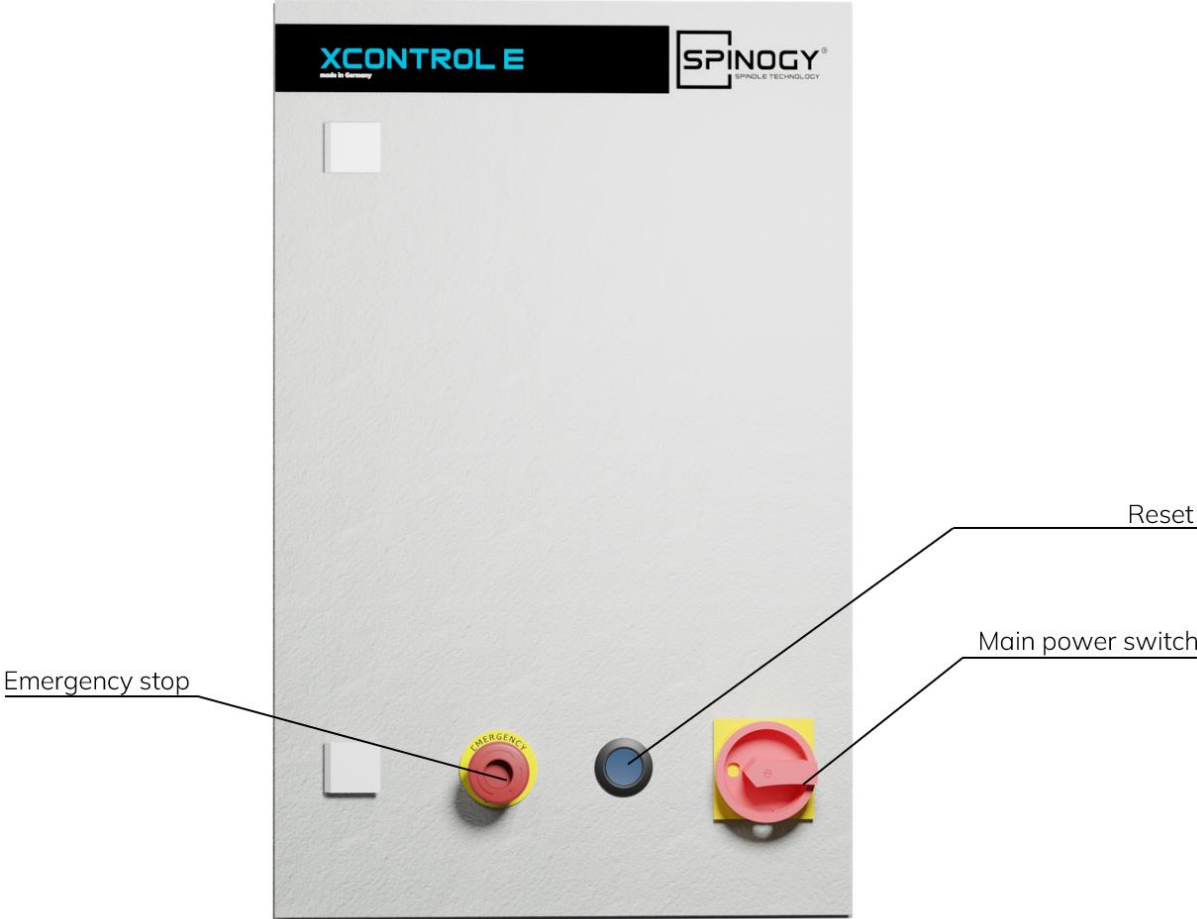

## View inside

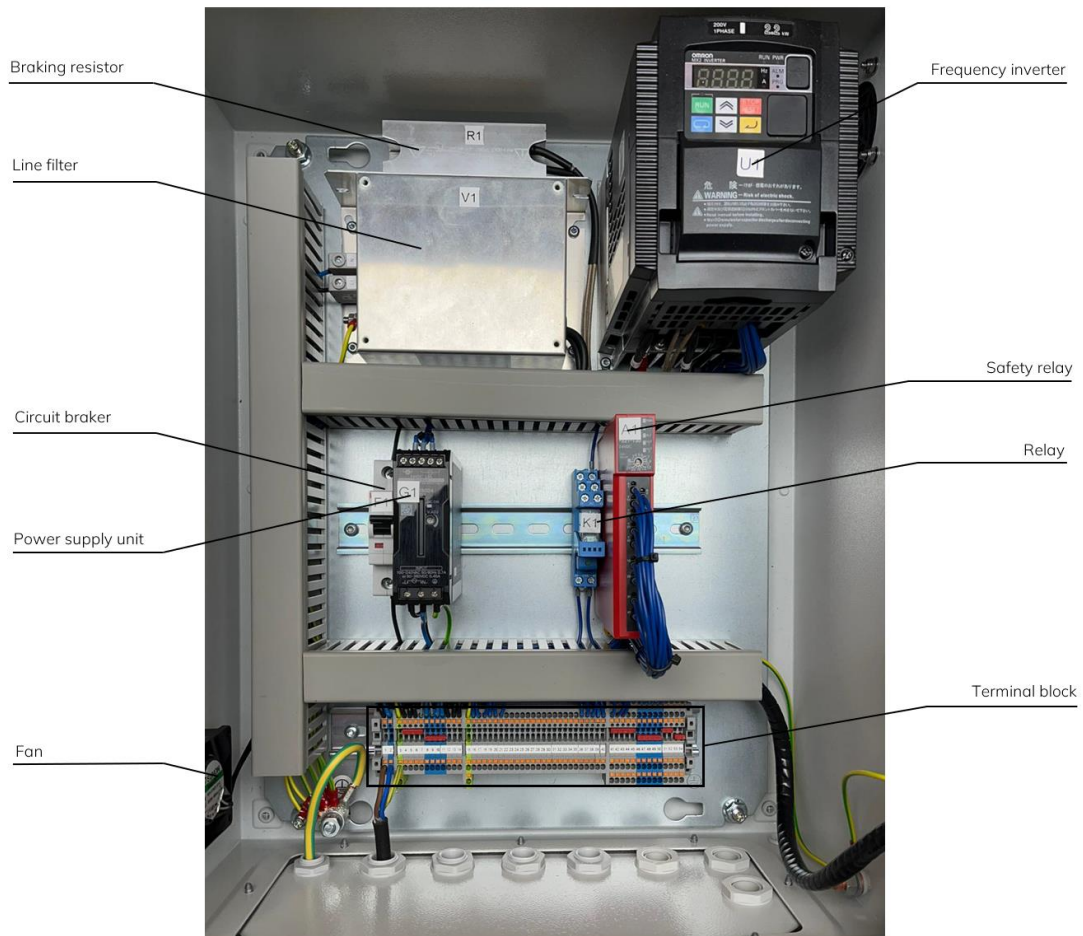

## View connection ports

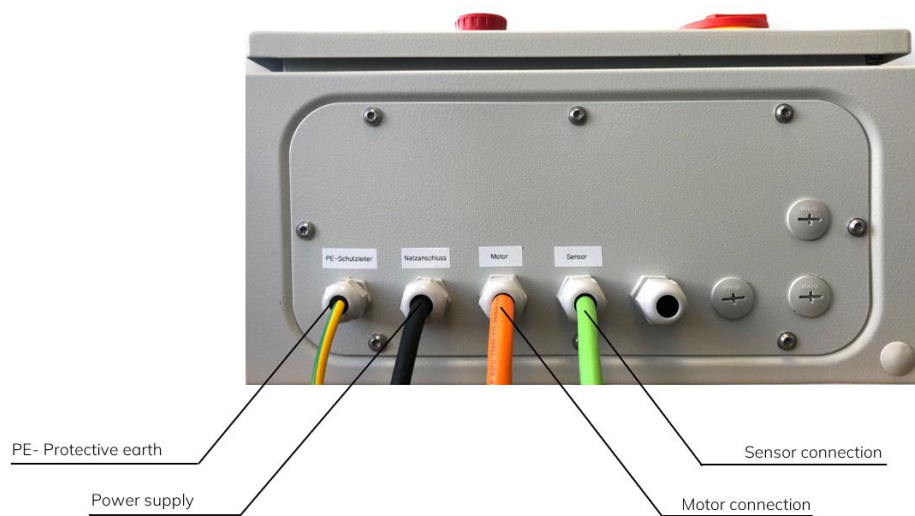

### Frequency inverter

Motor power [kW]	1,5	2,2	1,5	2,2
Nominal input voltage [V]	1-phase: 200 V –15 % to 240 V +10 % 50/60 Hz ±5 %		3-phase: 380 V –15 % to 480 V +10 % 50/60 Hz ±5 %	
Nominal output voltage [V]	3-phase: 200 bis 240 V		3-phase: 380 to 480 V	
Nominal output current [A]	8,0	11,0	4,8	5,5
Version	SVC oder HF			

### Braking resistor (10 % ED, max. 10s)

Voltage [V]	230 (1-phase)	400 (3-phase)
Motor power [kW]	1,5 or 2,2	1,5 or 2,2
Resistance [Ω]	70	200
Braking moment [%]	200	190

### Power supply unit

Power [W]	60
Output voltage [V]	24
Nominal current [A]	2,5
Ambient temperature [°C]	-40 – 70 °C

### Safety relay

Power [W]	Maximum 4
Supply voltage [V DC]	24
Direct switching outputs	2 normally open
Output with switch-off delay	2 normally open
Maximum turn-off delay time [s]	30
Ambient temperature [°C]	-10 to 55

### Relay

Supply voltages [V DC]	24
Maximum switched voltage [V DC]	250
Maximum switched current [A]	8
Contact type	2 changeovers
Ambient temperature [°C]	-40 to 70

### Circuit breaker

Operating voltage [V AC]	230
Type	1-pole B16 A
Nominal current [A]	16
Ambient temperature [°C]	-25 to 55

### Main switch

Maximum switched voltage [V AC]	690
Maximum switched current [A]	20
Ambient temperature [°C]	-25 to 50
Function	Locking
Feature	Lockable in 0-position



### Emergency stop

Maximum switching voltage [V AC]	240
Maximum switching current [A]	6
Contact type	2x Normally closed
Ambient temperature [°C]	-25 to 55
Function	Locking
Release type	Rotary release

## 04.3 Dimensions

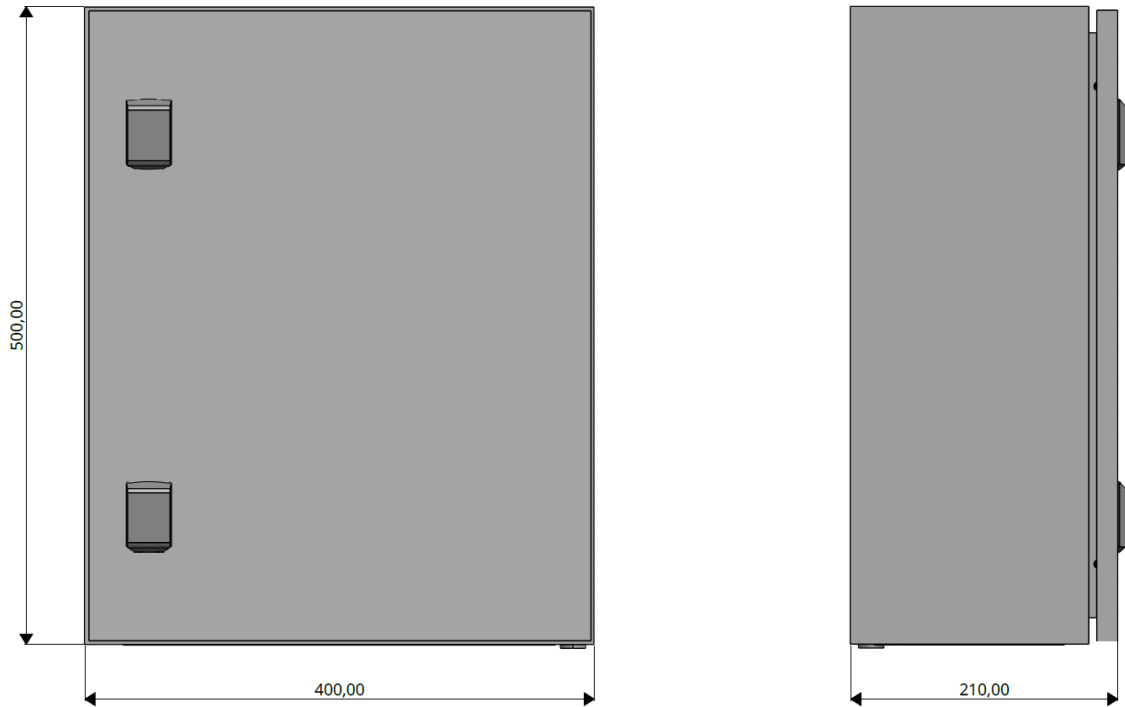

# 05 Installation

## 05.1 Transport damages check

The entire delivery must be checked for transport damage after acceptance. In case of external damage to the packaging, this must be documented. After unpacking the SPINOGY X22 and the additional scope of delivery, the products must be checked directly for transport damage. In case of damage to the products, this must be documented. Despite the greatest care in packaging and shipping our products, transport damage may occur as a result of improper handling or force majeure in transit. Defective or damaged products must not be put into operation. The products must always be used in perfect condition.

If transport damage is detected or if there are any questions, SPINOGY must be contacted immediately.

## 05.2 Completeness check

The content of the consignment must be checked for completeness. If any parts are missing, contact SPINOGY.

### Scope of delivery:

- Xcontrol-E
- Key for the door of the Xcontrol-E

## 05.3 Installation of the Xcontrol-E

The installation of the Xcontrol-E may only be carried out by qualified staff. During all work, the locally applicable occupational safety and accident prevention regulations as well as internal company regulations must be observed and complied with. Suitable tools must be used for the installation.



### **WARNING: Unauthorized staff**

Unauthorized employees are not aware of the hazards in the respective work area. Failure to comply with the personnel requisition can result in serious injury or even death.



### **WARNING: Falling parts**

During installation, components may fall, resulting in serious injury and property damage. It is recommended to work at least in pairs and to wear protective equipment and use appropriate tools.

The Xcontrol-E is to be installed in the following steps:

01. Mount the Xcontrol-E on the machine or on the wall.
02. Connect the separate protective earth conductor.
03. Connect the motor connection cable (orange) to the spindle.
04. Connect the sensor connection cable (green) to the spindle (only for spindles with sensors)
05. Connect the control cable to the terminals (not included in the scope of delivery).
06. Optionally: Connect an external emergency stop to the terminals (e.g. door safety switch).
07. Optionally: Connect the Xcontrol-P signal cable to the terminals.
08. Optionally: Connect the Xcool signal cable to the terminals.
09. Check, whether the main switch is set to 0/Off.
10. Check whether the circuit braker is set to 0/Off.
11. Check whether the emergency stop switch is activated.
12. Connect the power cord (directly, without power supply plug).
13. The circuit braker needs to be set to 1/On again.

The Xcontrol-E must be mounted vertically, the connection cables pointing downwards, as the heat convection of the frequency inverter is vertical. In addition, the Xcontrol-E must be suspended with sufficient distance to surrounding components so that the intake area of the fan and the air outlet remain free.

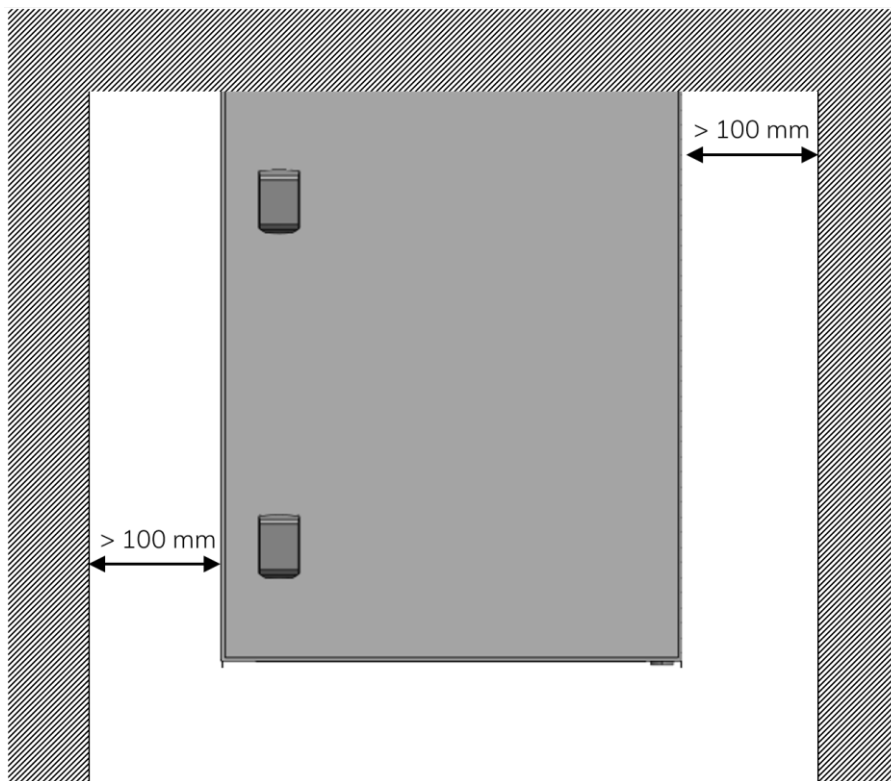

## 05.4 Electrical wiring

Connecting the Xcontrol-E must be done by a qualified electrician. In addition to the explanations in this chapter, the electrical circuit diagram of the Xcontrol-E must also be consulted.



**DANGER: Electrical voltage**

There is a risk of electric shock, which can cause serious injury or death. Before working on the Xcontrol-E, switch it off and disconnect it from the electrical network, and make sure that the capacitors of the frequency inverter are discharged.

All connections, leading out of the Xcontrol-E are connected internally to the terminal block X1. The terminals are assigned as follows:



	Lower row	Terminal	Upper row		
Power supply	L1	X1:1	F1:2	Circuit breaker	
	N	X1:2	Q1:4	Main switch	
	PE	X1:3	PE-Neutral point	Neutral point	
	-	X1:4	Q1:1	Main switch	
	-	X1:5	G1:L	Power supply unit	
	-	X1:6	V1:L	Input - power supply unit	
	-	X1:7	M1:1	Fan	
	-	X1:8	Q1:3	Main switch	
	-	X1:9	M1:2	Fan	
	-	X1:10	G1:N	Power supply unit	
	-	X1:11	V1:N	Input - power supply unit	
Motor connection cable	L1	X1:12	U1:U/T1	Frequency inverter	
	L2	X1:13	U1:V/T2	Frequency inverter	
	L3	X1:14	U1:W/T3	Frequency inverter	
	PE	X1:15	PE-Neutral point	PE-Neutral point	
	PE	X1:16			
	PTC +	X1:17	U1:5	Frequency inverter	
	PTC -	X1:18	U1:L	Frequency inverter	
Fan 0 V	X1:19	X1:53	0 V		
Fan 24 V	X1:20	X1:46	24 V		
Sensor connection cable	Pin1 0 V	X1:21	X1:48	0 V	
	Pin2 24 V	X1:22	X1:42	24 V	
Control cable (provided by the customer)	Clamped without tool S1	X1:23	Pin 3	Sensor connection cable	
	Clamped with tool S2	X1:24	Pin 4		
	Ejection position (piston) S3	X1:25	Pin 5		
	PT100 bearing front V+	X1:26	Pin 6		
	PT100 bearing front V-	X1:27	Pin 7		
	PT100 bearing back H+	X1:28	Pin 8		
	PT100 bearing back H-	X1:29	Pin 9		
	Encoder PZ	X1:30	Pin 10		
	Encoder NZ	X1:31	Pin 11		
	Signal rotational speed oder Encoder PA	X1:32	Pin 12		
	Encoder NA	X1:33	Pin 13		
	Encoder PB	X1:34	Pin 14		
	Encoder NB	X1:35	Pin 15		
	Encoder Vcc (5 V)	X1:36	Pin 16		
	-	X1:37	PE		
	Optional: 24 V from X1:44 with switch	X1:38	Optional: Xcontrol-P valve (cable Pin-1)		Optional: Xcontrol-P
	0 bis 10 V (spindle speed)	X1:39	U1:0		Frequency inverter
0 V (spindle rotational speed)	X1:40	(0V) (U1:L)	Frequency inverter		
0 V start signal spindle	X1:41	K1:A2	Relay (start/stop)		
Relay output to control	X1:42	A1:24	Safety relay U1:AL1 from FU		
Relays output to control	X1:43	U1:AL0	Frequency inverter		
Control cable (provided by the customer)	Optional: 24 V for Xcontrol-P to X1:38	X1:44	G1:V1+	Power supply unit 24 V	
	-	X1:45	A1:T33	Safety relay	
	-	X1:46	X1:20	Fan spindle 24 V	
	-	X1:47	A1:37	Safety relay 24 V U1:3/GS1	
	-	X1:48	X1:21	Sensor connection cable 24 V	
	-	X1:49	A1:47	Safety relay 24 V U1:4/GS2	
	-	X1:50	K1:A1	Relay 24 V	
Control cable (provided by the customer)	Optional: Xcontrol-P valve (cable Pin-2)	X1:52	A1:A1	Safety relay 24 V	
	-	X1:53	G1:V1-	Power supply unit 0 V	
Control cable (provided by the customer)	-	X1:54	X1:19	Fan spindle 0 V	
	Potential machine control (0 V)	X1:55	X1:22	Sensor connection cable 0 V	
External emergency stop (remove bridge)	-	X1:56	X1:40	machine control 0 V	
	Ext. Emergency stop (channel 1)	X1:57	A1:A2	Safety relay 0 V - power supply	
	Optional: Xcontrol-P pressure switch (cable Pin-4)	X1:58	S1:2	Emergency stop (channel 1)	
	Ext. Emergency stop (channel 2)	X1:59	Optional: Xcontrol-P pressure switch (cable Pin-3)		
	Optional: Xcool Pin-3	X1:60	A1:T12		
-	X1:61	S1:4	Emergency stop (channel 2)		
-	X1:62	Optional: Xcool Pin-1			

## Connection of the separate protective earth conductor and the power supply cable

The Xcontrol-E is to be operated stationary, and it is not allowed to connect it via plug socket, but directly.



### **DANGER: High leakage current**

High leakage currents may occur. The Xcontrol-E must be operated stationary. It is not allowed to connect it via power supply plug, but directly. The separate protective earth conductor must be attached in any case. Otherwise, there is a risk that the high leakage currents will flow through people and, in the worst case, can lead to death.

The separate protective earth conductor must be installed in such a way that there is permanent electrical patency between the protective earth conductor and other equipment. In addition, sufficient mechanical protection and strength of the protective conductor must be ensured. The protective earth conductor must be connected as follows:

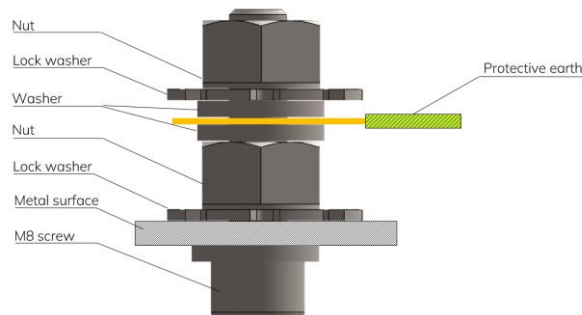

## Connecting motor connection cable and sensor connection cable

The connection of the motor supply cable and the sensor connection cable to the spindle can be found in the operating manual of X22.

### **Control line customer**

The control cable, via all signals run from the machine control to the Xcontrol-E, must be connected to the terminal block by the customer. For this purpose, the terminal block positions X1:17 and X1:18 as well as X1:23 and X1:43 and X1:55 are provided. Depending on the spindle configuration, not all terminals are necessary, but they are already installed in case that the spindle should be upgraded in the future.

The control cable must have a cable cross-section in the range of 0.08 to 1.5 mm<sup>2</sup>. It is recommended that the wires are fitted with ferrules to ensure optimum contact. The terminals are to be operated as explained in the following picture, e.g. with a screwdriver. Afterwards the wire can be inserted into the terminal and the screwdriver can be removed again. (Check if the wire is firmly seated).

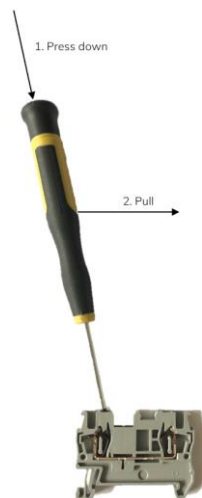

The following chart shows the functions of the terminal blocks X1:17 to X1:55:

Terminal	Function
X1:17	PT100 coil end + (not necessary for PTC)
X1:18	PT100 coil end – (not necessary for PTC)
X1:23	Clamped without tool S1
X1:24	Clamped with tool S2
X1:25	Ejection position (piston) S3
X1:26	PT100 bearing front V+
X1:27	PT100 bearing front V-
X1:28	PT100 bearing back H+
X1:29	PT100 bearing back H-
X1:30	Encoder PZ
X1:31	Encoder NZ
X1:32	Signal rotational speed or encoder PA
X1:33	Encoder NA
X1:34	Encoder PB
X1:35	Encoder NB
X1:36	Encoder Vcc (5 V)
X1:37	-
X1:38	Optional: Xcontrol-P valve
X1:39	0 to 10 V (spindle rotational speed)
X1:40	0 V (spindle rotational speed)
X1:41	0 V start signal spindle
X1:42	Relay output Xcontrol-E to machine control (opens when activating emergency stop)
X1:43	
X1:55	Potential machine control (0 V)

#### Optional: External emergency stop

The terminal blocks X1:57 to X1:58 and X1:60 to X1:61 can be used for the integration of an external 2-pole emergency stop signal. For example, the signal of a safety door can be integrated.

Terminal	Function
X1:57	External emergency stop channel 1 (Normally closed)
X1:58	
X1:60	External emergency stop channel 2 (Normally closed)
X1:61	

For the integration, the bridges between the terminal blocks must be removed.

### Optional: Integration of Xcontrol-P

There is the possibility to integrate the Xcontrol-P pneumatic control system into the Xcontrol-E. This means that the 24 V from the Xcontrol-E can be used for switching the valve. In addition, the pressure switch of the Xcontrol-P can be integrated into the safety circuit so that the emergency stop can be activated, and the spindle stopped if the pressure falls below the required level.

For integration of the valve see wiring diagram below:

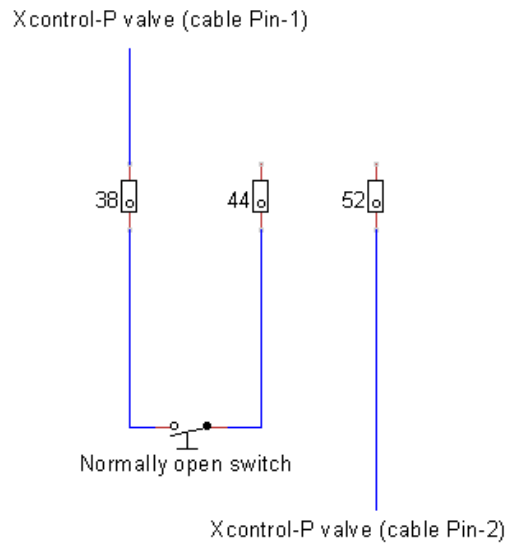

The connection cable of the Xcontrol-P needs to be inserted into the Xcontrol-E. Pin 1 of the cable must be inserted to terminal X1:38 (upper row), Pin 2 to X1:52 (lower row). For activating the valve, a switch between terminal X1:44 (lower row) and X1:38 (lower row) can be integrated.

For integration of the Xcontrol-P pressure switch see wiring diagram below:

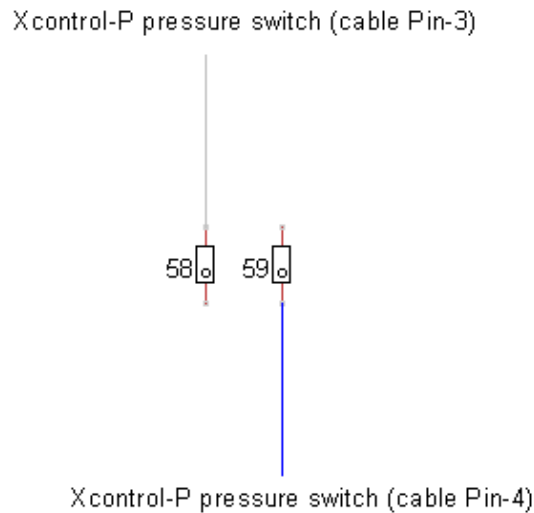

Pin 3 of the Xcontrol-P connection cable must be inserted to terminal X1:58 (upper row) and Pin 4 to terminal X1:59 (lower row). Therefore, the bridge between X1:58 and X1:59 must be removed.

### Optional: Integration of Xcool

There is the possibility to integrate the cooling unit Xcool into the Xcontrol-E. The relay output signal of the Xcool can be integrated into the safety circuit, so that in the event of a temperature or flow error, the emergency stop is activated, and the spindle is stopped.

For integration of the Xcool see wiring diagram below:

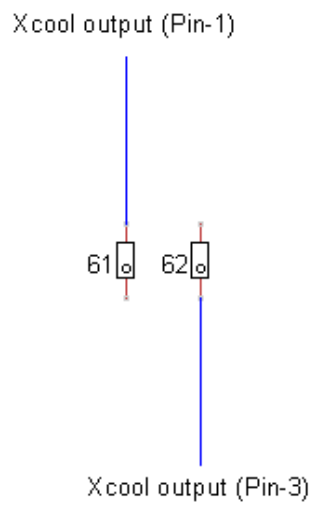

Output Pin 1 of the Xcool must be connected to terminal X1:61 (upper row) and output Pin 3 to terminal X1:62 (lower row). Therefore, the bridge between X1:61 and X1:62 must be removed.



# 06 Commissioning



## **WARNING: Machinery Directive 2006/42/EC must be applied**

Before placing on the market or commissioning a machine into spindle is installed, the manufacturer or operator must ensure that the Machinery Directive 2006/42/EC applies. For this purpose, reference is made to Article 5 of the current valid Machine Guideline.

Furthermore, it must be checked whether other regulations or directives apply and must be complied with.

## 06.1 Power-on test

Before switching on the Xcontrol-E for the first time, check the following points:

01. Is the circuit breaker set to "1/On"?
02. Is the emergency stop activated?

After that, the main switch can be set to "1/On" and the following points must be checked:

03. Is the fan of the Xcontrol-E switched on?
04. Is the frequency inverter switched on and shows 0.00?
05. Do the PWR-LEDs on the safety relay burn?

Now the emergency stop switch can be unlocked and the reset-button pressed. The following points must be checked:

06. Do the PWR, IN-1 and IN-2 LEDs on the safety relay burn?

After completing this process, check the following points:

07. Start via machine control
08. Stop via machine control
09. Emergency stop by activating the emergency stop switch
10. Emergency stop via external emergency stop (optional)
11. Emergency stop via Xcontrol-P, e.g., by lowering the pressure (optional)
12. Emergency stop via Xcool, e.g., by removing the plug (optional)
13. Release via reset button after emergency stop (only possible after at least 5 seconds)
14. Trying all Xcontrol-E output signals to machine control (e.g., sensors)
15. Trying whether the maximum speed set on the control is displayed on the frequency inverter

After the power-on test has been completed, the door must be closed and locked via the two locks.

Now the Xcontrol-E is ready for use.

## 06.2 Commissioning for regular use

The following steps must be carried out during regular commissioning of the Xcontrol-E:

01. Check if the emergency stop is activated
02. Set the main switch to "1/On"
03. Check if the fan of the Xcontrol-E is switched on
04. The emergency stop switch is to be unlocked
05. The system is to be released via the reset button
06. Perform a check at the control unit. Are all output signals of the Xcontrol-E displayed?
07. The Xcontrol-E is ready for use

# 07 Maintenance

## 07.1 Maintenance

The operator is committed to check and maintain the Xcontrol-E, which is considered as an electrical system, in such a way that technical safety is ensured at any time with all relevant laws and standards. The following points must be checked or carried out at regular intervals:

- Check circuit breakers, contractors and relays for wear or damage
- Check connecting lines and cables for damage and fastening
- Check for dirt or corrosion
- Check switching operation and control operation
- Clean fan filter and check fan for proper functioning
- Carry out „DGUV V3“ inspection („Deutsche gesetzliche Unfallversicherungs-Vorschrift 3“ Association of Occupational Accident Insurance Funds – regulation 3“) or a comparable regulation

Maintenance work may only be carried out by qualified and trained personnel.

## 07.2 Spare parts

If spare parts are required, SPINOGY is to be contacted.

# 08 Disassembly and disposal

## 08.1 Disassembly

The disassembly as well as the decommissioning of the Xcontrol-E may only be carried out by qualified staff. During all work, the locally applicable occupational safety and accident prevention regulations as well as internal company regulations must be observed and complied with. Suitable tools must be used for disassembly.



**WARNING: Unauthorized staff**

Unauthorized employees are not aware of the hazards in the respective work area. Failure to comply with the personnel requisition can result in serious injury or even death.



**WARNING: Repairs by operators or third parties are not permitted**

Unauthorized repairs carried out by the operator or third parties can result in the product not being in a perfect condition afterwards, which can lead to property damage and, in the worst case, serious injury or even death.

The Xcontrol-E is to be put out of operation in the following steps:

01. The entire machine or system must be taken out of operation before the Xcontrol-E is decommissioned. To complete this, proceed as follows:
  - a. Stop the spindle and make sure that the shaft is absolutely stationary (eject the tool via pneumatic actuation if necessary)
  - b. Activate the emergency stop of the machine or system (if separate to the Xcontrol-E)
  - c. Set the main switch of the machine or system to "0" or "Off"
  - d. Secure the machine or system against unauthorized restarting
  - e. Disconnect the machine or system from the electric network. Physically disconnect the power supply lines and discharge any stored residual energy.
02. Press the emergency stop of the Xcontrol-E.
03. Set the main switch of the Xcontrol-E to "0" or "Off".
04. Set the circuit breaker inside the Xcontrol-E to "0" or "Off".
05. The power supply cable leading to the Xcontrol-E must be disconnected from the electrical power supply.
06. Disconnect all connections to the spindle and the control unit (spindle connection lines, control lines, separate PE Protective earth)
07. If necessary, the Xcontrol-E can be removed from the machine or wall

## 08.2 Disposal

The disposal of the Xcontrol-E, any accessories and the packaging must be carried out in accordance with the relevant laws and regulations of the respective country. If in doubt, contact the relevant local authority or a waste disposal company. Depending on the material, the individual components should preferably be recycled. Disposal with domestic waste or similar facilities for the collection of municipal waste is not permitted.

After consulting SPINOGY, the Xcontrol-E can be returned directly to the manufacturer. In this case, a disposal fee may be charged by the manufacturer.

# 09 Service and repair

## 09.1 Service and repair authorized users

Repairing of components of the Xcontrol-E may only be carried out by SPINOGY, since only then a perfect function can be guaranteed. If unauthorized repairs are carried out, any warranty and guarantee claim expires and SPINOGY is not liable for any resulting damage to property or personal injury.



**WARNING: Repairs by operators or third parties are not permitted**

Unauthorized repairs carried out by the operator or third parties can result in the product not being in perfect condition afterwards, which can lead to property damage and, in the worst case, serious injury or even death.

# 10 Warranty

SPINOGY warrants the product against material defects excluding further claims, considering the following points:

01. The warranty period from the date of delivery is 24 months in accordance with statutory provisions.
02. In case of justified complaints of the goods, recognized by SPINOGY, which had their cause probably before the passage of risk of the goods - this concerns in particular the detective function, defects of the external condition or the delivery of a wrong product - According to the German Civil Code (called "BGB" = "Bürgerliches Gesetzbuch") Paragraph § 439 (passage 1) the ordering party may choose between two options: There is the option to have the defect repaired free of charge by SPINOGY and there is the other option to have it replaced by a defect-free product. The determination of above-mentioned defects at the products must be announced immediately to SPINOGY by documenting it in a written or graphic form. The claim of the guarantee presupposes that SPINOGY receives the possibility for the examination of the guarantee case, even if this requires to send in the product.
03. The claim for rectification of defects is not applicable if SPINOGY is entitled to refuse the rectification of defects due to legal regulations. This applies in particular in the case that the subsequent improvement is accompanied by disproportionately high costs. In this case, according to German Civil Code (called "BGB" = Bürgerliches Gesetzbuch") Paragraph § 439 (passage 4), the purchaser's right to subsequent performance is limited to the other option.
04. If more than 6 months have passed since the purchase of the product, the obligation to provide proof, is with the customer. The customer has to prove that the defect already existed before delivery. This applies in particular to defects that are not immediately apparent.
05. Any parts or products replaced under warranty shall become the property of SPINOGY, unless SPINOGY expressly waives such right.
06. For all necessary rework and replacement deliveries, the buyer has to set an appropriate period after consulting SPINOGY. If this is not the case, SPINOGY is released from the liability of resulting consequences.
07. If the warranty claim turns out to be legally valid, the costs arising from a rectification or replacement delivery plus the shipping costs are to be paid by SPINOGY. If the customer initiates the inspection of a product delivered by SPINOGY, and it turns out that there is no warranty case, that means, there are no defects to be complained about, or these are based on reasons SPINOGY is not responsible for, a cost lump sum will be charged according to the service and additional services of SPINOGY.
08. No warranty is given by SPINOGY in the following cases:
  - Improper use
  - Incorrect assembly or disassembly by the purchaser or third parties
  - Incorrect commissioning or decommissioning by the purchaser or third parties
  - Unauthorized modifications of the product
  - Usual wear and tear (e.g. spindle bearings)
  - Improper maintenance
  - Incorrect or careless handling
  - Incorrect storage
  - Disregard of the operating instructions
  - Defects the purchaser already knew at the time of the purchase
  - Force majeure
  - Unsuitable operating site
  - Chemical, electrochemical or electrical influences
09. The ordering party shall be entitled to withdraw from the agreement under the legal provisions if SPINOGY - subject to legally specified exceptions - misses a reasonable deadline set for the improvement or delivery of a replacement product. If there is an insignificant defect, the purchaser shall only be entitled to a reduction of the contract price.
10. In case of self-remedy of defects by the purchaser or third parties, SPINOGY is not liable for the resulting consequences. The same applies to changes made, which SPINOGY has not agreed to.
11. SPINOGY reserves the right to make technical changes to the product (e.g. constructive) without prior notification.
12. SPINOGY reserves the right to update the product to the latest state of the art by carrying out repairs.

# 11 Declaration of installation

(According to EC Machinery Directive 2006/42/EC annex II B)

Original document

**Manufacturer:**

SPINOGY GmbH  
Brunnenweg 17  
64331 Weiterstadt  
Deutschland

**Authorized to issue documents:**

SPINOGY GmbH  
Brunnenweg 17  
64331 Weiterstadt  
Deutschland

We hereby declare that the following product

<b>Product</b>	Motor spindle control
<b>Type</b>	Xcontrol-E
<b>Serial number</b>	

complies with the following basic requirements of the guideline machines (2006/42/EC):  
Annex I, subchapter 1.1.2, 1.1.3, 1.1.5, 1.3.2, 1.3.4

The partly completed machine may only be put into operation until it has been determined that the machine into the partly completed machine is to be installed, complies with the purpose of the Machinery Directive (2006/42/EC) and the EC Declaration of Conformity according to Annex II A is available.

The special technical documents belonging to the partly completed machine according to Annex VII Part B have been created and are kept accordingly.

The manufacturer commits to provide the special technical documents according to Annex VII, Part B, for the partly completed machine to individual national authorities in digital form, upon reasonable request.

If the partly completed machine is modified after it has been handed over to the user without our approval, this declaration loses its validity with immediate effect.



Marc Schmidt-Winterstein  
Authorized representative for documentation

©SPINOGY GmbH

Rev.07/2022