



LS-635B Laser System Operating Manual



QUANTUM COMPOSERS, INC
PO Box 4248
Bozeman, MT 59772
(406)582-0227 phone
(406)582-0237 fax
www.quantumcomposers.com

Contents

1. INTRODUCTION	4
Technical Support.....	4
Warranty.....	4
Package Contents.....	4
2. SAFETY.....	5
<i>Laser Safety</i>	6
<i>Safety Issues</i>	7
<i>Electrical Safety</i>	8
Sources of Laser Safety Standards.....	8
Safety Labels and Locations.....	9
3. CE DECLARATION OF CONFORMITY	13
4. SYSTEM OVERVIEW	14
<i>LS-635B Block Diagram</i>	14
Rack Mount Power Supply.....	14
Table Top Power Supply.....	15
Description of Payload.....	16
Description of the Jewel Laser.....	16
Laser Optic Assemblies.....	16
5. INSTALLATION	19
<i>Unpacking the Laser System</i>	19
System Inventory.....	19
<i>System Installation</i>	20
Payload Setup.....	20
Power Supply Setup.....	21
Optional System Connections.....	22
System Indicators.....	23
Laser Disable (EMO).....	23
Initial Power On.....	23
6. LASER OPERATION	24
<i>Manual Operation</i>	24
7. SYSTEM OPERATION	25
<i>LS-635B Communication Application</i>	25
Getting Started.....	25
Laser Control.....	26
Cut Size.....	27
Illumination.....	27
8. RS-232 COMMUNICATIONS	28
<i>Personal Computer to Laser System Communication</i>	28
RS-232 Interface Overview.....	28
Device Command Format.....	29
Device Addresses.....	29
<i>Command Types</i>	29

Control Commands	29
Query Commands	30
Error Codes	30
Laser Controller Example	30
General System Commands	33
Laser Operation Commands.....	33
Illuminator Commands	35
Calibration Commands.....	35
9. MAINTENANCE	36
10. TROUBLE-SHOOTING	36
No Laser Output.....	36
Energy is Low	36
11. SPECIFICATIONS.....	37
LS-635B Laser Specifications	37
Attenuator Specifications	37
X-Y Slit	38
Theta Slit	38
Filter Wheel.....	38
Positions.....	38
Tact Time	38
Initialization	38
System.....	39
12. CABLES AND CONNECTION PINOUT	40
<i>Umbilical Cable</i>	40
Control Cable	40
13. CUSTOMER SERVICE	41
<i>Warranty</i>	41
Feedback.....	41
14. APPENDIX A - FUSE REPLACEMENT	42

1. Introduction

This manual is a reference designed to familiarize you with the Quantum Composers LS-635B series laser system and is arranged so that you can easily find the information you're looking for. Generally, each topic has its own section and no section assumes that you've read anything else in the manual.

Technical Support

For questions or comments about operating the LS-635B our technical staff can be reached via one of the following methods:

- Phone – 1 (406) 582-0227
- Fax – 1 (406) 582-0237
- Internet - www.quantumcomposers.com

Warranty

The LS-635B has a one-year limited warranty from the date of delivery. This warranty covers defects in materials and workmanship. Quantum Composers will repair or replace any defective unit. Contact us for information on obtaining warranty service.

Package Contents

The box you receive should contain the following:

- LS-635B Laser System Payload
- LS-635B Laser System 2U Rack Mounted Power Supply
- Umbilical Cable – (length specified at time of order)
- AC Power Cord (for country of use)
- User's Manual and Control Software on Disk
- Acceptance Test Results

Contact Quantum Composers 1 (406) 582-0227 if any parts are missing.

2. Safety

This user’s manual contains the technical information needed to properly install, operate, and maintain the LS-635B laser system. It provides instructions for setup and installation, operation, service, preventive maintenance, and troubleshooting (fault-isolation). The laser system consists of two major subassemblies:

1. The Payload, which consists of a laser, laser optics, and all supporting control circuits.
2. The Laser Power Supply, which consists of a 2U rack mounted box. Connect the two with a supplied Umbilical Cable. Length of cable is specified at time of order.

The laser system is truly “turn-key” and has been shipped fully functional. Only minor adjustments are necessary after installing to operate the system. The umbilical connections are sized and keyed to increase the simplicity of installation.

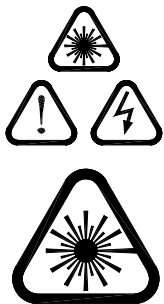

Caution labels, in accordance with CDRH and CE requirements, are prominently displayed on the Laser Optical Assembly and Laser Power Supply. The maximum ratings indicated on the system labels are in excess of the normal operating parameters. Please refer to the Data Summary Sheet for specific information pertaining to your system.

The laser system produces laser radiation, which is hazardous to eyes and skin, can cause burning and fires and can vaporize substances. The safety chapter contains essential information and user guidance about these hazards.

This product complies with safety standards EN 61010-1:2010, EN 60825-1:2014, and CDRH21 CFR 1040.10(d). Do not install substitute parts or perform any unauthorized modification to this product. Return the product to manufacturer for service or repair to ensure that all safety features are maintained.

Do not operate this product beyond its specifications. If this equipment is used in a manner not specified by the manufacturer, the protection provided by the equipment may be impaired.

SYMBOL	DEFINITION OF SYMBOL
	<p>CAUTION: Calls attention to a procedure, practice, or condition that could cause damage to the product, or cause bodily injury to the user. Refer to accompanying documentation.</p> <p>ATTENTION: Ce symbole signale une procédure, une méthode ou une condition qui peut endommager le produit ou blesser l'utilisateur. Se référer à la documentation jointe.</p> <p>ACHTUNG!: Beachten Sie Verfahren, Praktiken oder Zustände, die das Produkt beschädigen oder zu Verletzungen führen können. Lesen Sie die beigefugte Dokumentation.</p> <p>ATTENZIONE: Porre estrema cautela alla procedura, uso o condizioni che potrebbero danneggiare il prodotto o l'utilizzatore. Far riferimento alla documentazione inviata insieme al prodotto.</p> <p>ADVERTENCIA: Llamar la atención de un producto, practica, o estado que puede causar daño al producto o puede herir el usuario.</p>

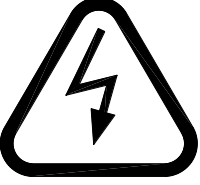
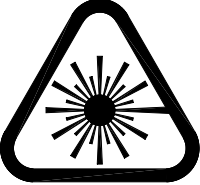
	<p>CAUTION: Risk of Electric Shock.</p> <p>ATTENTION: Risque d'électrocution.</p> <p>ACHTUNG!: Gefahr durch Stromschlag.</p> <p>ATTENZIONE: Rischio di shock elettrico.</p> <p>ADVERTENCIA: Riesgo de choque eléctrico</p>
	<p>CAUTION: Risk of exposure to hazardous laser radiation.</p> <p>ATTENTION: Risque d'exposition à un rayonnement laser dangereux.</p> <p>ACHTUNG!: Gefahr durch gefährliche Laserstrahlung.</p> <p>ATTENZIONE: Rischio di esposizione a pericolose radiazioni laser.</p> <p>ADVERTENCIA: Riesgo de exposición a radiación láser peligrosa.</p>

Laser Safety

VISIBLE AND/OR INVISIBLE LASER RADIATION



CAUTION: The LS-635B Laser System is a Class 4 OEM laser. Its output beam is, by definition, a safety and fire hazard. Precautions must be taken to prevent accidental exposure to both direct and reflected beams.

Precautions for Safe Operation of Class 4 OEM Lasers:

- Keep the protective covers on the Laser Head as much as possible. Do not operate the laser with the covers removed for any reason.
- Avoid looking at the laser output beam.
- Do not wear reflective jewelry while using the laser, as it might cause inadvertent hazardous reflections.
- Use protective eyewear at all times. Consult the ANSI, ACGIH, or OSHA standards listed at the end of this section for guidance on goggles and safety matters.
- Operate the laser at the lowest possible beam intensity, given the requirements of the intended application.
- Increase the beam diameter wherever possible to reduce beam intensity and thus reduce the hazard.
- Avoid blocking the laser beam with any part of the body.
- Use an IR detector or energy detector to verify that the laser beam is off before working in front of the laser.
- Establish a controlled access area for laser operation. Limit access to those trained in the principles of laser safety.

- Maintain a high ambient light level in the laser operation area so the eye pupil remains constricted, thus reducing the possibility of hazardous exposure.
- Post prominent warning signs near the laser operation area.
- Provide enclosures for the beam path whenever possible.
- Set up an energy absorber to capture the laser beam, preventing unnecessary reflections or scattering.



CAUTION: Use of controls, adjustments or performance of procedures other than those specified in this User's Manual may result in hazardous radiation exposure.

- Follow the instructions within this manual carefully to ensure the safe operation of your laser. At all times during laser operation, maintenance, or servicing, avoid unnecessary exposure to laser or collateral radiation that exceeds the accessible emission limits listed in "Performance Standards for Laser Products," United States Code of Federal Regulations, 21 CFR 1040.10(d). This information is also available in EN 60825-1:2014, Section 8.2, titled "Measurements of Laser Radiation for Determining Classification."
- Preventative Maintenance for Safety
- Preventative maintenance is required to ensure the laser remains in compliance with Center for Devices and Radiological Health (CDRH) Regulations and European Norm (EN) requirements. This laser product complies with Title 21 of the United States Code of Federal Regulations, Chapter 1, Subchapter J, Parts 1040.10, as applicable, and with EN 60825-1:2014, Part 1 for a Class 4 laser, as applicable. To maintain compliance, verify the operation of all features listed below, either annually or whenever the product has been subjected to adverse environmental conditions, which may have affected these features and functions.
- Verify that removing the remote interlock connector prevents laser operation. This connector is located on the rear panel of the Laser Power Supply.



WARNING: Please note that the remote interlock is a control interlock, and it is not applicable for a safety related function.

Safety Issues

Normal use of test equipment presents a certain amount of danger due to electrical shock because it may be necessary for testing to be performed where voltage is exposed.

An electrical shock causing 10 milliamps of current to pass through the heart will stop most human heartbeats. Voltage as low as 35 VDC or 35 V_{RMS} AC should be considered dangerous and hazardous, as it can produce a lethal current under certain conditions. Higher voltages pose an even greater threat because such voltage can easily produce a lethal current. Your normal work habits should include all accepted practices that will prevent contact with exposed high voltage and steer current away from your heart in case of accidental contact with a high voltage. You will significantly reduce the risk factor if you know and observe the following safety precautions:

- If possible, familiarize yourself with the equipment being tested and the location of its high-voltage points. However, remember that high voltage may appear at unexpected points in defective equipment.
- Do not expose high voltage needlessly. Remove housing and covers only when necessary. Turn off equipment while making test connections in high-voltage circuits. Discharge high-voltage capacitors after shutting down power.
- When testing AC powered equipment, remember that AC line voltage is usually present on power input circuits, such as the on-off switch, fuses, power transformer, etc.
- Use an insulated floor material or a large, insulated floor mat to stand on, and an insulated work surface on which to place equipment. Make certain such surfaces are not damp or wet.
- Use the time-proven “one hand in the pocket” technique while handling an instrument probe. Be particularly careful to avoid contact with metal objects that could provide a good ground return path.

Never work alone. Someone should always be nearby to render aid if necessary. Training in CPR first aid is highly recommended.

Do not position the equipment such that it is difficult to unplug in the event of an emergency.

Only the power supply cord supplied with the Equipment or an Approved equivalently rated cord suitable for this application shall be used.

Electrical Safety

CAUTION: Both the Laser Optics Assembly and Laser Power Supply contain electrical circuits operating at lethal voltage and current levels. Always unplug the system Mains connection and wait at least one (1) minute to allow capacitors to discharge before servicing any part of the laser system.

Consult with the manufacturer if repair of the laser electronics is required. Only those trained in high voltage, high current electronics, and who understand the laser circuitry, should be allowed to service and repair the laser electronics. If any such action is required, it is recommended that you contact the manufacturer for details.

NOTE: The system, as constructed, is not suitable for installation on an IT distribution circuit. In the event of use on an IT distribution circuit, additional upstream protection must be provided, in both ungrounded phases, rated 7A or less.

Sources of Laser Safety Standards

"Safe Use of Lasers" (Z136.1)
American National Standards Institute (ANSI)
11th West 42nd Street
New York, NY 10036 USA

Phone: (212) 642-4900

"A Guide for Control of Laser Hazards"

American Conference of Governmental and Industrial Hygienists (ACGIH)
6500 Glenway Avenue, Bldg. D-7
Cincinnati, OH 45211 USA
Phone: (513) 661-7881

Occupational Safety and Health Administration

U.S. Department of Labor
200 Constitution Avenue N.W.
Washington, DC 20210 USA
Phone: (202) 523-8148

"Safety of Laser Products" (EN 60825-1:2014)

Global Engineering Documents
15 Iverness Way East
Englewood, CO 80112-5704 USA
Phone: (303) 792-2181

Safety Labels and Locations

The following figures show the safety labels, model number, serial number and origination labels, and their locations on the LS-635B Laser System. These labels are installed at the factory and should not be removed by the user. If for some reason a label is removed, obscured or damaged in any way, please contact the manufacturer for a replacement.



Figure 1 Certification & ID Label

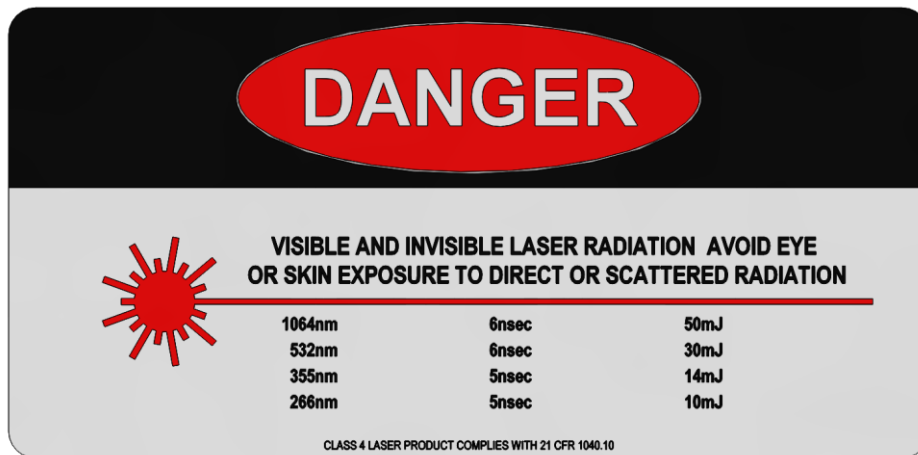

Figure 2 Laser Wavelengths Label



Figure 3 Laser Aperture

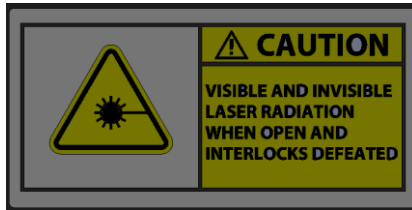

Figure 4 Cover Exposure Label



Figure 5 Attention Label

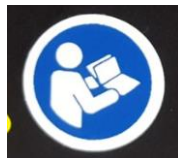

Figure 6 Read Manual Label



Figure 7 Model, Serial, and Origination Label, Attention, Read Manual

Figure 8 LS635 Safety Labels





Figure 9 Attention and Red Manual Labels

3. CE Declaration of Conformity



MANUFACTURERS DECLARATION OF CONFORMITY

Manufacturer's Name Quantum Composers, Inc.
Manufacturer's Address 212 Discovery Drive
Bozeman, Montana 59718
Model Name(s) LS-625, LS-635 & LS-635B Laser Micromachining Systems
Year of Manufacture 2018

The object of the declaration described above is in conformity with the relevant Union harmonization legislation:

Application of Council Directive(s) EMC Directive 2014/30/EU
Low Voltage Directive (LVD) 2014/35/EU

The following harmonized standards and technical specifications have been applied:

Conformance to Low Voltage Directive:
EN 61010-1:2010
EN 60825-1:2014
EMC Directive:
EN 55011: 2009 + A1: 2010
EN 61326-1:2013
EN 61000-3-2: 2006 + A1: 2009 + A2: 2009
EN 61000-3-3: 2008

We, the undersigned, hereby declare that the equipment specified above conforms to the above Directive(s).

Location Bozeman, Montana Representative Name Steve Birrell

Date October 6, 2015 Title Engineering Manager

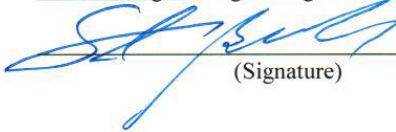
(Signature)

4. System Overview

LS-635B Block Diagram

Figure 10 shows the laser system block diagram, which consists of the Jewel Laser, the laser optic modules, and the System Power Supply.

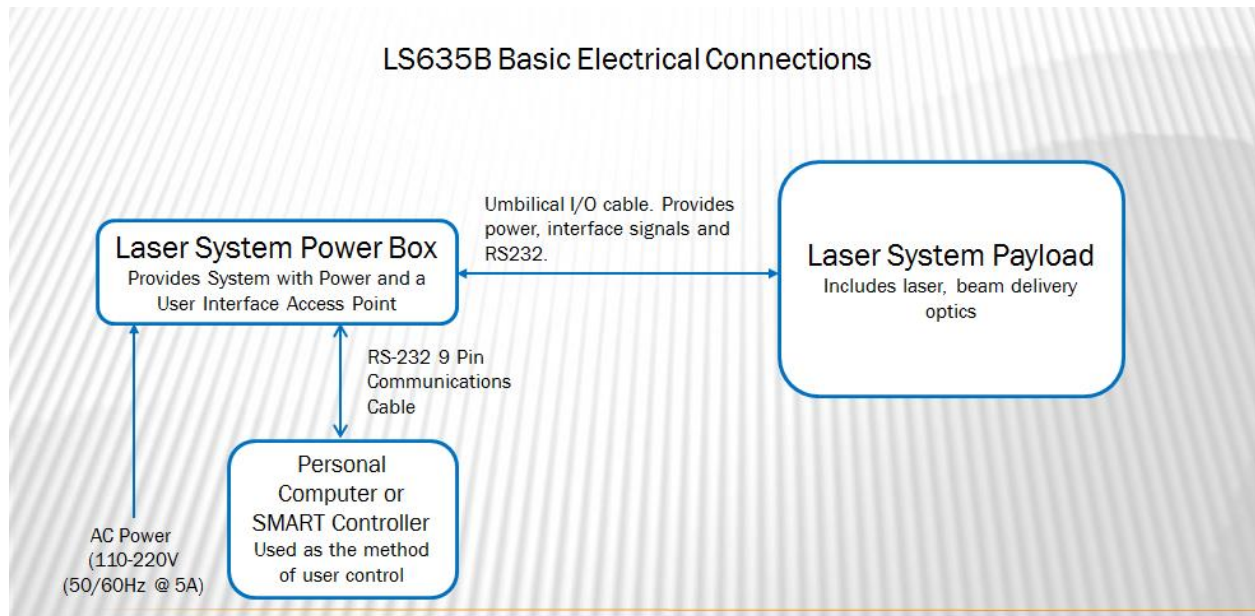

Figure 10 System Block Diagram

Rack Mount Power Supply

The 2U rack mounted power supply box contains an AC/DC converter to supply the needed voltage for the LS-635B system from one AC supply. The main source can be 100-240 VAC and 50-60 Hz. The power supply box makes use of convective air-cooling. This box also contains the input ports for RS-232 communications from a user supplied computer, two external triggers, an external interlock, and a sync out signal.



Figure 11 Power Supply (front view)



Figure 12 Power Supply (Connections)

Table Top Power Supply

The Table Top power supply box contains similar components as the rack mount power supply but in a Table Top package.

The laser optical assemblies (shown in Figure 15) are explained below.

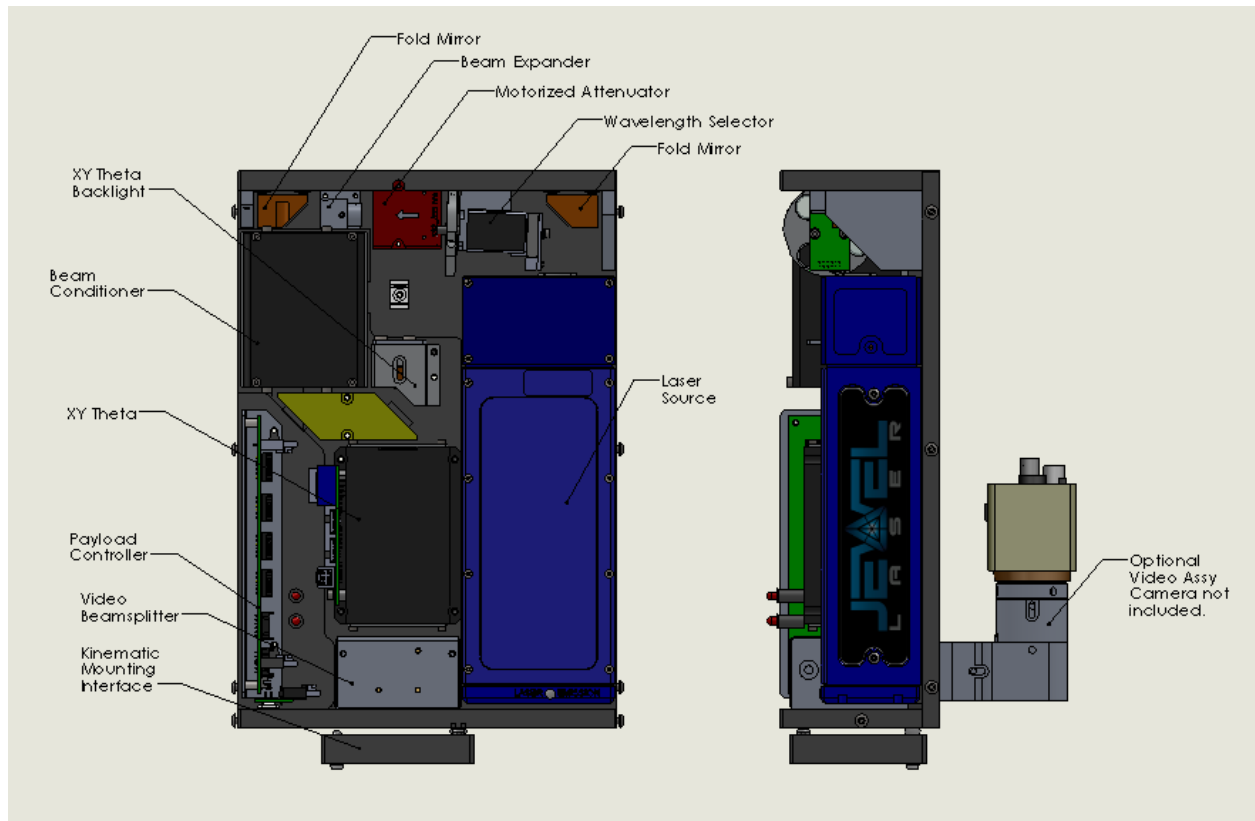

Figure 15 Laser Optical Assembly

1. The resonator is a diode pumped laser with an output wavelength of 1064 nm and nonlinear module to perform harmonic generation to produce a few key wavelengths. The resonator monolithic structure is machined from a single block of stress-relieved aircraft grade aluminum. Resonator mirrors are hard-mounted to the machined resonator bench, which results in an extremely stiff, rugged resonator which is much less sensitive to misalignment than standard laser resonators. The output of the laser enters the integral nonlinear module. Harmonic generation is performed using non-linear crystal(s). The crystal temperature is tightly regulated by mounting them inside a temperature controlled oven assembly. The laser head has a nonlinear optic (NLO) crystal mounted inside a nonlinear module. The output is collinear, with all wavelengths exiting the same aperture.
2. The laser beam leaves the laser and is reflected off of the Fold Mirror to the Wavelength Selector. The Wavelength Selector contains filters to separate the beam into discrete wavelengths and allow the selection of High or Low energy modes.
3. The next component in the beam path is the attenuator. The attenuator is used to control the amount of energy exiting the payload. The attenuator is designed with a waveplate/polarizer to provide motorized attenuation of the laser beams from 0-100% of the full energy at the given wavelength. The attenuator utilizes high precision encoders to provide closed-loop motor control.
4. The beam expander follows the attenuator. The beam expander enlarges the laser beam for the proper illumination of the XY Theta aperture.

5. The fold mirror reflects the laser beam down to the beam conditioner. The beam conditioner mixes the laser beam and produces a more uniform profile at the XY Theta aperture. This ensures the cuts made by the LS-635B system are clean and uniform.
6. The laser beam is offset by the parallel mirror assembly so that it is nominally centered on the XY Theta Aperture.
7. The laser beam illuminates the XY Theta aperture. The XY Theta aperture forms a rectangular shape and each axis is independently controlled. The rectangular shape can be rotated ± 45 degrees from horizontal. Stepper motors with precision all metal gear heads are used to provide reliable and repeatable attenuation.
8. The Aperture Backlight shines through the 2nd mirror of the Parallel Mirror assembly to illuminate the XY Aperture. When mounted in a system with the appropriate video optics, the Slit aperture can easily be viewed indicate where the laser cuts will occur.
9. The Beam Splitter assembly separates the visual wavelengths from the laser beam path for viewing with a machine vision camera.
10. The Camera Port allows a machine vision camera to be utilized for viewing of the laser process. The Camera Port is a **CS-mount** (1.00"-32 thread).

5. Installation

Unpacking the Laser System

The laser system has been carefully packaged for shipment. If the container arrives damaged in any way, please contact the shipper's agent to be present for the unpacking. Inspect each unit as it is unpacked, looking for dents, scratches, or other damage. If damage is evident, immediately file a claim against the carrier and notify the manufacturer.

It is recommended that the shipping container be kept for possible further shipping purposes, should the unit require repair or maintenance services. If a damage claim has been filed, the container will be needed to prove shipping damage.

The laser system is a turnkey system, designed so that a field service engineer is not required to get the system up and operating properly. The system has undergone extensive testing to verify its conformance to the specifications prior to delivery.

Before operating the laser however, it is important to fully understand its main features and controls.



CAUTION: Do not power up the system before thoroughly reading the system description. Use of the controls or adjustments, or performance of procedures other than those specified in this user's manual may result in hazardous radiation exposure, laser system damage or result in voiding the warranty. Please refrain from connection the main power until you make sure the power switch is in the OFF position.

System Inventory

The LS-635B system consists of the following items. Verify that all listed items are present in the shipping container. If there are any shortages or discrepancies, contact Quantum Composers immediately.

- LS-635B Laser System Payload
- LS-635B Laser System Power Supply
- Umbilical Cable – (length specified at time of order)
- AC Power Cord (for country of use)
- User's Manual and Control Software on Disk
- Acceptance Test Results

System Installation



CAUTION: When utilizing the Remote Interlock capability, use an isolated contact closure such as a relay to avoid generating undesirable ground loops.



CAUTION: Ensure that the system is connected to the proper Mains voltage. The voltage rating is marked on the Laser Power Supply back panel. Operating the system at the incorrect voltage may result in damage to the unit.



CAUTION: Ensure that the Mains power outlet that the Laser Power Supply connects to is properly grounded. Poor ground quality could result in exposure to electrical shock.

NOTE: The system, as constructed, is not suitable for installation on an IT distribution circuit. In the event of use on an IT distribution circuit, additional upstream protection must be provided, in both ungrounded phases, rated 7A or less.

Payload Setup

1. Remove payload from packaging and lift onto microscope mount. Secure with 8-32 set screws (2).

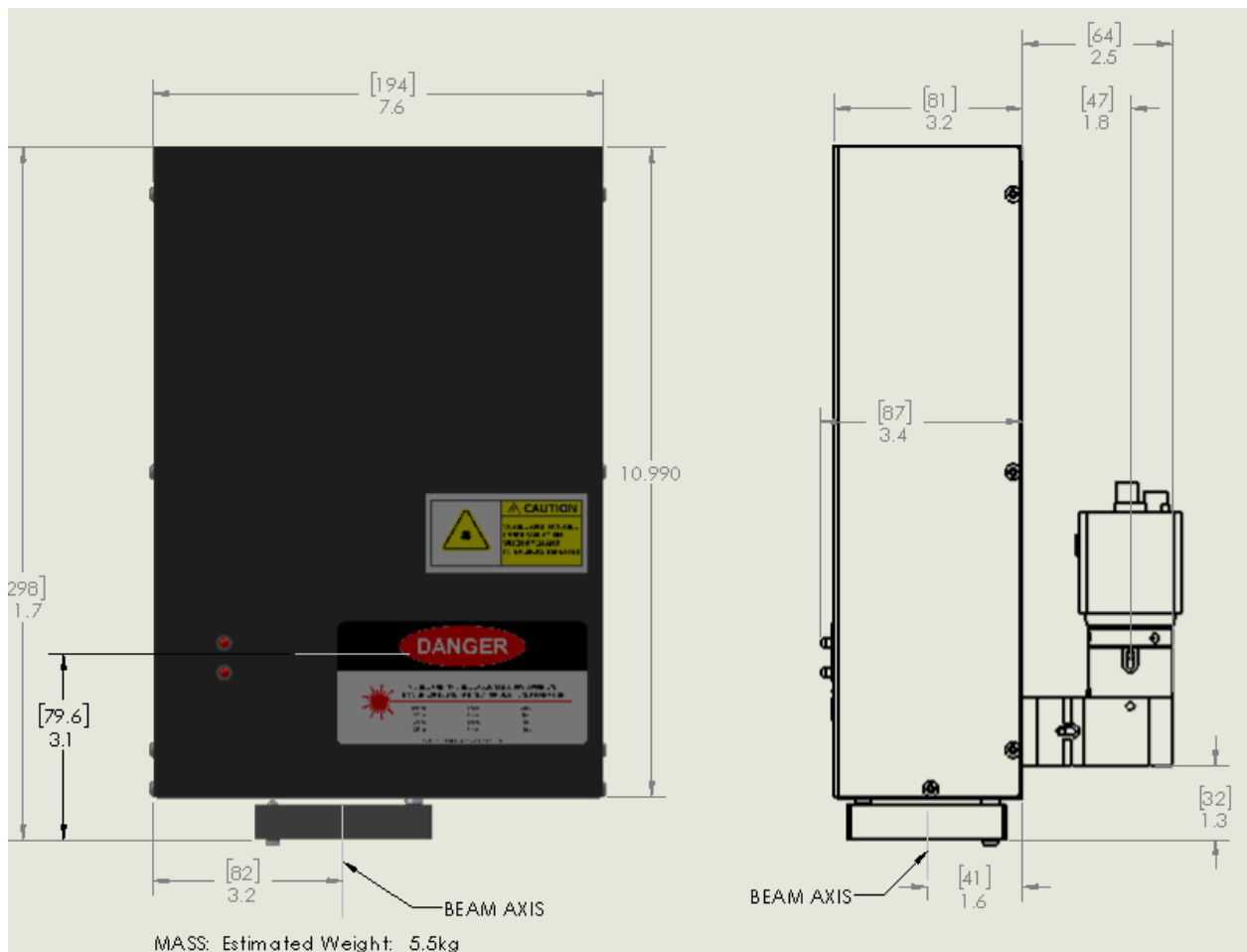

Figure 16 Mechanical Interface

Power Supply Setup

Rack Mount Power Supply

1. Slide the 2U 19" rack mount power supply into a suitable rack.
2. Attach umbilical cabling to back of power supply and connect the opposite end to the payload. The connections are specific so that connectors cannot be miss-matched. Payload 1 will connect to Laser Signal (Payload 2 is not used on the LS635B).
3. Connect the RS 232 to a computer serial port using a standard 9 pin serial cable.
4. Plug in the AC power to a suitable 100-240 VAC supply using the provided IEC plug.



Figure 17 Power Supply Connections (Payload2 not installed)

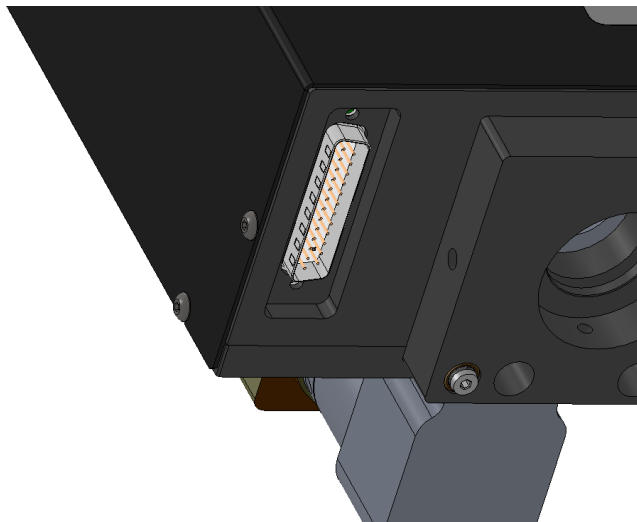

Figure 18 Payload Electrical Connection

Table Top Power Supply

1. Select a suitable location for the power supply so the umbilical cables can reach the payload without tight bends.
2. Attach umbilical cabling to back of power supply and connect the opposite end to the payload. The connections are specific so that connectors cannot be miss-matched. Payload 1 will connect to Laser Signal (Payload 2 is not used on the LS635B).
3. Connect the RS 232 to a computer serial port using a standard 9 pin serial cable.
4. Plug in the AC power to a suitable 100-240 VAC supply using the provided IEC plug.

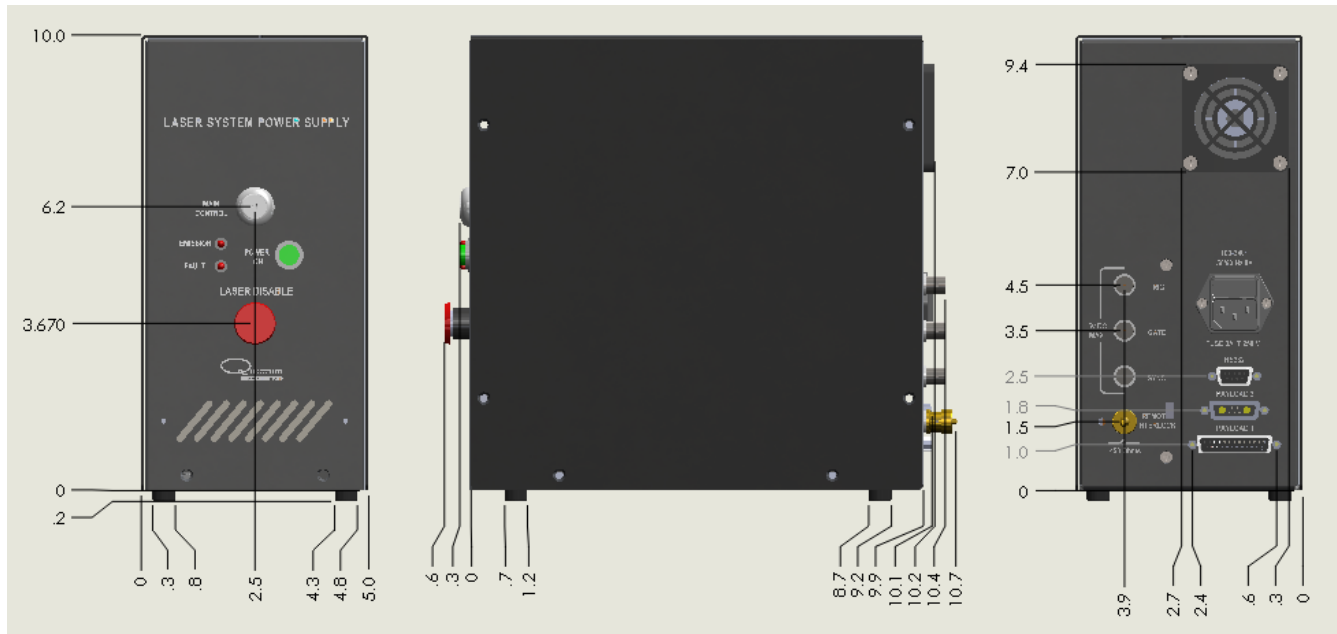

Figure 19 Table Top Power Supply

Optional System Connections

The Laser Power Supply has optional connections that can be used if desired see Figure 17 Power Supply Connections.

1. Remote Interlock. The remote interlock can be connected to any normally closed switch such as a door or access panel. If not used, the shorting jumper must be connected. When opened, the system will indicate an interlock fault and stop firing the laser. While this interlock is a control interlock, it may not be applicable for a safety related interlock.
2. Sync. The sync connection is an output that can indicate various system states depending on the state of the sync output settings (see command set). The signal present on this connector will be 5V max amplitude. The output can indicate the laser diode pulse state, the laser diode and q-switch states or the firing state.
3. Trig and Gate. These are optional inputs that can be customized based on application needs. Please contact the factory for your needs if externally triggering or gating the system is required.

System Indicators

The system has multiple visual indicators that show the state of the system. Both the Laser Power Supply and the Payload have Emission and Fault indicators. The Emission indicator will be active when the laser is enabled and able to be actively fired. The Fault indicator will be active whenever a fault has occurred.

Laser Disable (EMO)

The system Laser Power Supply has an emergency EMO switch that when depressed will disconnect all power supplies inside the system. This is an AC disconnect. The system will completely shut down and all communication will be lost. This switch should only be used when the system needs to be shut down quickly and full power disconnect is desired. The system will not power on with this switch depressed.

Initial Power On

Power-On Checklist

- Verify cable connections are correct.
- Verify that EMO switch is not activated.

Turn on system power.

1. The laser harmonic crystal(s) will warm up to the set temperature. This takes approximately 15 minutes.
2. The attenuator will independently home upon power up.
3. The XY Theta aperture will home upon power up.
4. The filter wheel will home on power up.
5. The output polarizer will home on power up.

The system will be ready to operate after approximately 2 minutes. Best laser performance will require another 8 minutes of warm-up time.

6. Laser Operation

The laser system has undergone extensive testing to verify its conformance to the specifications prior to delivery.

Once the laser system has been set up as outlined in the previous chapter, it is ready to operate. Turn ON the Laser Power Supply. After approximately 2 minutes, the laser system is initialized and ready for operator control.

NOTE: Laser harmonic crystals must warm up. This can take 15 minutes before stable output energy can be realized.

Manual Operation

Manual operation should be done via computer as described below. The Laser Power Supply has been pre-configured for operation in the LS-635B Laser System. For a description of the various controls see the communications section.



CAUTION: Manual operation should only be done by trained service technicians. Control of the laser should normally be done using the master controller interface. Failure to properly set all modules before firing the laser can result in damage to the system.



CAUTION: Below is a list of guidelines, which apply to all Quantum Composers' laser systems. These guidelines should be followed whenever possible to avoid laser damage.

- Operate the laser in a dust-free environment and keep the Laser Optics Assembly covered when not in use. This protects the output aperture against dust and particulate.
- The Laser Optics Assembly is sealed with careful attention to use of low outgassing materials. Silicone and similar sealing, bonding or insulating materials should not be used in close proximity to the Laser Optics Assembly since these substances will outgas and could contaminate the output window, causing laser damage.
- Avoid back reflections. Back reflections of even a small percentage of the output energy can promote damage to optical components in the Laser Head. For example, an uncoated convex lens or a glass disk calorimeter will reflect about 4% of the incident energy. While the reflection may seem harmless, it can perturb the resonator operation to the extent that the near field beam intensity profile is degraded and may promote optical damage. It may also affect the resonator hold-off, which can cause prelasing and catastrophic optical damage. In some cases, even anti-reflection coated glass optics can reflect enough energy to promote damage to laser optics. It is best to use only quality optics coated for the operating wavelength.



CAUTION: To avoid laser damage, minimize back reflections of the output beam. When reflections are unavoidable, direct them away from the optical axis of the system by canting the optics off-axis. Failure to do so can cause laser damage and void the warranty.

7. System Operation

LS-635B Communication Application

A software communication application has been included on the System Disc that can operate and set all the functions of the LS-635B laser system. This communication application communicates with the LS-635B via an RS-232 serial interface with the Laser System Controller.

Getting Started

- Attach a serial cable from the RS-232 port of the computer to the “Comm In” serial port on the Laser System Power Supply Box.
- Start the LS6xx software.
- The LS-635B application startup screen will be displayed as shown in Figure 20. This application has been designed as a graphical user interface for ease of use. There is a Command Terminal section that can be used as well in order to manually send and receive commands to the laser system. This area allows the user to enter a command and press Send or Enter key. The large area shows the command that was sent and the response. The large area also shows the commands and responses from controls in other portion of the Graphical User Interface (GUI).
- The software allows you to run the basic functions of the laser system. From this screen the user can pick laser wavelength, energy level, firing mode, frequency, adjust aperture size, and set the slit backlight illumination level.
- The software also provides a system status indicator for the major interlocks and faults.

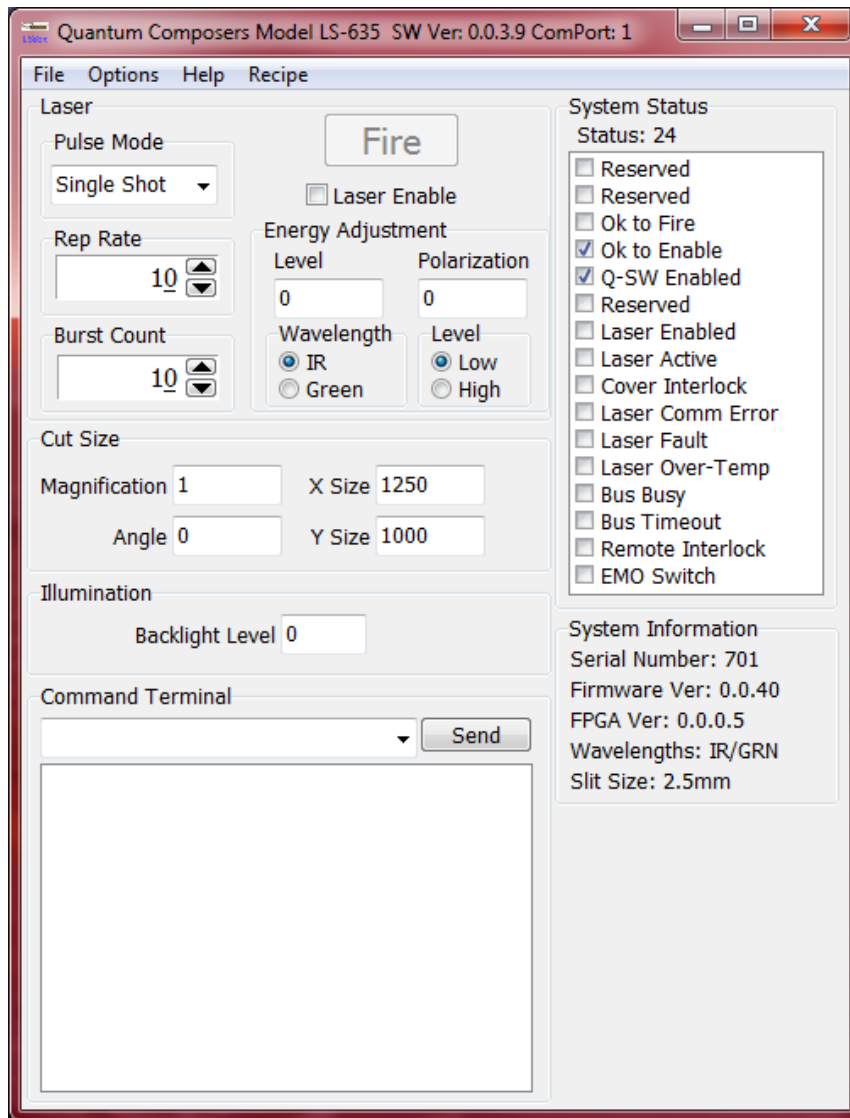

Figure 20 LS6xx Software Application Opening Screen

Laser Control

1. Pulse Mode – Options are continuous, single shot or burst.
 - a. Continuous mode – The laser will fire continuously from the time the Fire button is pressed until the Stop button is pressed. The pulses per second are controlled with the Rep Rate parameter.
 - b. Single Shot – The laser will output 1 single laser pulse when the Fire button is pressed.
 - c. Burst mode - The laser will output the number of laser pulses specified by the Burst Count parameter. The laser will stop firing at the end of the burst.
2. Fire button – Selecting the fire button will start laser output. NOTE: the laser must be enabled before the Fire button becomes active.
3. Energy Adjustment – Range for each wavelength is 0 to 1000 (0 to 100.0%).
4. Wavelength Adjustment – Choose one of the two available wavelengths to be used.
5. Power Level Adjustment – Options are High and Low power.
 - a. High Power – The laser energy will range from 0 to the value set with the calibration command. (See ECS in the command section).
 - b. Low Power – The laser energy will range from 0 to 25% of the value set with the calibration command. (See ECS in the command section).

Cut Size

The cut size value is measured at the sample. Example: a 2500 μ m aperture opening with a 50x microscope objective has a cut size of 50.00 μ m.

1. Magnification – specified magnification of microscope objective being used.
2. X-size & Y-size – value corresponds to image size which is determined by the aperture size (range 0 to max size) divided by the microscope objective magnification. The max size of the aperture is specified at time of order. The system ID? query will tell you what size slit is installed on the system.
3. Angle – Values are \pm range of 0 to 450 (45.0 degrees). Positive values rotate the aperture positive, Negative values rotate the aperture negative. A “-“ must be entered for the aperture to rotate in the negative direction.

Objective Magnification	Max Size for 2.5mm Slit (mm)	Max Size for 4mm Slit (mm)
1x	2500	4000
2x	1250	2000
5x	500	800
10x	250	400
20x	125	200
50x	50	80
100x	25	40
200x	12.5	20

Illumination

The LS63x is configured with an illuminator used to show the XY-Theta aperture.

1. Backlight Level – values are 0 to 1000 (0 to 100.0%).

8. RS-232 Communications

Personal Computer to Laser System Communication

The LS-635B has a standard RS-232 port. All menu settings can be set and retrieved over the computer interface using a simple command language. The command set is structured to be consistent with the Standard Commands for Programmable Instruments (SCPI). Although due to the high number of special features found in the LS-635B, many of the commands are not included in the specification. Sending commands faster than 50 ms may cause the unit to not respond properly. It is advised to wait until a response from the previous command is received before sending the next command.

RS-232 Interface Overview

The serial port is located on the back of the LS-635B rack mounted power box and uses a 9-pin D-type connector with the following pinout (as viewed from the back of the unit):

1	No Connection
2	Tx - Transmit (to computer)
3	Rx - Receive (from computer)
4	DTR - Connected to pin 6
5	Ground
6	DSR - Connected to pin 4
7	RTS - Connected to pin 8
8	CTS - Connected to pin 7
9	No Connection

The serial port parameters should be set as follows:

Baud Rate	57600
Data Bits	8
Parity	Even
Stop Bits	1

Device Command Format

All commands use ASCII characters and are composed of the following fields:

<Prefix><Address>< Delimiter ><Command String>[Parameters]<Terminator>

Field	Description
Prefix	Single semicolon character ";", must precede all commands. All devices will reset their command input buffer when the prefix is received.
Address	2 ASCII characters. Each device has a unique address which is programmed into its firmware. See the table below for a list of addresses.
Delimiter	Single colon character ":", must follow device address.
Command String	Commands are specific to each device -- see the following sections for the commands that each device supports.
Parameters	(optional field) Some commands may not require a parameter. For Query commands immediately follow the command string with the question mark character "?". For non-query commands immediately follow the command string with a single space character " " followed by the parameter. Multiple commands are separated by commas.
Terminator	ASCII carriage return character (ODh). The receiving device does not process any commands until the terminator is received.

Device Addresses

Address	Device
LC	Laser Controller

Command Types

There are two types of commands -- those that set a value or initiate an action (control commands), and those that request information (query commands). Each device must respond in the proper manner to each type of command.

Control Commands

A device must always parse a control command and return a response immediately.

- If the command is a recognized command and the parameter is valid, then the device returns an "OK<CR>".
- If the command is not recognized, then the device responds with a "?1<CR>".
- If the command is recognized, but the parameter value is missing or invalid, then the device responds with a "?4" or "?5".
- If a control command is received while the device is in the midst of executing a previous command, and the commands are mutually exclusive (cannot be executed in parallel), then the previous command is aborted and the new one executed. It is up to the host controller (the PC) to poll the device and make sure the previous command has finished, if that is needed.

Query Commands

Query commands return a value to the PC as soon as the command is parsed and executed. The value returned will depend on the command. The response is always terminated with a "<CR><LF>". If a query command is not recognized by the device, then a "?1" is returned.

Error Codes

- ?1 Command not recognized.
- ?2 Missing command keyword. If command requires keyword.
- ?3 Invalid command keyword. If command requires keyword.
- ?4 Missing parameter.
- ?5 Invalid parameter.
- ?6 Query only, command needs a question mark.
- ?7 Invalid query, command does not have a query function.
- ?8 Command unavailable in current system state.
- ?9 Module timeout error

Laser Controller Example

Below is an example of commands and queries. A <CR> indicates the carriage return value appended. The system will initialize itself on power up. There is no need to home any motors or stages. The system will power up with the last saved recipe (if saved). See the SR and LR commands.

Example Recipe:

Laser Mode: Burst of 10, Rate of 10Hz.
Wavelength: 266nm
Energy Level: High mode at 50%.
Cut Size: 1um x 1um, 45 degree rotation with 10x objective.
Output polarization: 0 degrees.
Backlight Illumination: On at 20%.

Command Sequence:

Command to send: ;LC:EN 1<CR>
Response: OK<CR>
Description: This will enable the laser. This only needs to be done once unless a fault disables it or a laser disable is sent.

Command to send: ;LC:PM 2<CR>
Response: OK<CR>
Description: This sets the laser pulse mode to burst.

Command to send: ;LC:BC 10<CR>
Response: OK<CR>
Description: Sets the laser burst count to 10.

Command to send: ;LC:RR 10<CR>
Response: OK<CR>
Description: Sets the laser rep rate to 10Hz

Command to send: ;LC:SW 4<CR>
Response: OK<CR>
Description: Sets the active wavelength to DUV (266nm).

Command to send: ;LC:ED 4,1,500<CR>
Response: OK<CR>
Description: Sets the wavelength to DUV (266nm), the level to high mode and the percentage to 50%.

Command to send: ;LC:SP 10,1000,1000<CR>
Response: OK<CR>
Description: Sets the slit opening to 1um x 1um with a 10x objective.

Command to send: ;LC:SA 450<CR>
Response: OK<CR>
Description: Sets the slit angle to 45 degrees.

Command to send: ;LC:IL 1,200<CR>
Response: OK<CR>
Description: Sets the backlight illumination to 20% on.

The system is now ready to fire the laser:

Command to send: ;LC:FL 2<CR>
Response: OK<CR>
Description: Starts the laser firing the burst sequence.

To monitor system status, use the SS command:

Query to send: ;LC:SS?<CR>
Response: 208<CR>
Description: Means laser Q-Switch is enabled, laser is enabled and laser is active. Bit 4, 6 and 7 are set.

Once the burst is finished another FL 2 command can be sent to fire another burst.

If it is desired to save this recipe for a recall later on, use the following command:

Command to send: ;LC:SR 1<CR>
Response: OK<CR>
Description: Saves the current system settings to storage location #1. There are up to 6 locations to store various recipes.

To recall a saved recipe, use the following command:

Command to send:	;LC:LR 2<CR>
Response:	OK<CR>
Description:	Loads the configurations settings from storage location #2.

Once a recipe is recalled, the only commands that need to be sent are the enable laser (EN) and the fire laser (FL). It is recommended to utilize the recipe storage and recall commands to quickly load new parameters into the system that have been pre-configured.

To minimize the number of setup commands that have to be sent each time when parameters need to change quickly, the laser setup (LS) command can be used. This command combines many of the commonly changed parameters. If the objective magnification stays the same, then this command can be used.

Command to send:	;LC:LS 4,1,500,0,1000,1000<CR>
Response:	OK<CR>
Description:	Sets wavelength to DUV, level to high, energy to 50%, polarization to 0 degrees, and slit to 1um x 1um.

Various System Status Checks

To check to see if the laser is ready to be enabled, only one bit (bit position 3) of the system status needs to be checked. This bit is the Ready to Enable bit. When this bit is set, then the laser can be issued an enable command. If it is not set, then check to see if any fault is detected.

To check to see if the laser is ready to fire, only the Ready To Fire bit (bit position 2) needs to be checked. When this bit is set, it is ok to send the fire laser command. If it is not set, then check to see if the laser is enabled or if any other fault is detected.

To monitor the status of any motor movement in the system, only the Bus Busy (or motor moving) bit (bit position 12) needs to be checked. This bit will be set whenever any motor on the system is in motion. This could be due to a homing sequence on startup or a commanded movement is still in process.

General System Commands

DONE?	Done Firing. This query will send back a “done” response once the laser is finished firing. An example situation would be waiting for a burst to finish. Once the burst is done, the “done” response will be sent back. If the system is not ready to fire then a response of “?8” will be returned.						
EC # EC?	Echo. Parameter = 0=echo characters off (Default: 0), 1=echo characters on. EC? returns echo state.						
ID?	System ID. QC, model #, serial # (5 digits),FW Version# (x.x.x), GA Version#(x.x.x),Wavelengths, Slit Size. Example: QC,LS-635B,00101,1.2.0,0.8.3,IR/GRN,2.5mm). Query only						
LR # LR?	Load Recipe. Sets up laser according to requested recipe settings. Parameter = Recipe number (0=factory default, 1-6 User Recipes).						
HA	Home All. Homes all motors on the system. Once homing is complete motors will move to the last set position.						
HR	Home Reset. Homes all motors on the system. Once homing is complete motors will move to the power on default positions.						
RDY?	Ready to Fire. This query will send back a “rdy” response once the system is ready to fire. If motors are in motion the response will not come back until they are done moving. Any command sent while waiting for the response will abort the query. If the system is in a fault condition a “?8” will be returned.						
SR # SR?	Store Recipe. Store current settings. Parameter = Recipe number (1-6 User Recipes). A query returns the current active recipe.						
SS?	System Status – Query Only. Returns the current system state. Value is a 16 bit decimal value with each bit position corresponding to a system state.						
15	14	13	12	11	10	9	8
EMO	Remote Intlk	Bus Timeout	Bus Busy (motors moving)	Laser Over Temp	Laser Fault	Laser Comm Error	Cover Interlock
7	6	5	4	3	2	1	0
Laser Active	Laser Enabled	Reserved	Qswitch Enabled	Ready to Enable	Ready to Fire	Reserved	Reserved
ST	Stop. This is a global stop to the system. The laser will be disabled, the motors will all be stopped.						
VN?	Version Number – Query Only. Returns the current LSC version number in the format of major.minor.release. Ex: 1.3.6						

Laser Operation Commands

BC # BC?	Burst Count. Sets the number of laser shots to be fired when firing mode is set to burst. Parameters are from 1-1000. Default is 10. A query will return the currently set burst count.
ED #,#,### ED?	Set Energy Density. Parameters: First parameter selects wavelength. Range is 1 to 4 where 1 = IR, 2 = GRN, 3 = UV, 4 = DUV. Second parameter selects High (1) or Low (0). High mode gives 100% of full scale and Low mode is 25% of full scale. Third parameter is Energy Density (0 – 1000). Where 1000 equals the wavelength/mode specific

	maximum output. ED? returns current energy density setting. The format of the query is #,#,####.
EN # EN?	Enable. This will enable or disable the laser. The laser must first be enabled before firing. 0 = Disabled, 1 = Enabled. (Default: 0). A query returns the current enable state.
FL # FL?	Fire Laser. Starts the laser pulsing. 0 = Stop Firing Laser, place laser in idle state, shutter will be closed. 1 = Fire laser, shutter is closed. 2 = Fire laser, shutter is open. A query returns the current firing state.
LS #,#,###,###,###,### LS?	Laser Setup. This is a combined command to adjust multiple system parameters at once instead of issuing multiple commands. First Parameter = Select wavelength (1 = IR, 2 = GRN, 3 = UV, 4 = DUV), Second Parameter = Selects High (1) or Low (0) mode, Third Parameter = Set Energy Density (0 – 1000), Fourth Parameter = Set polarization angle (-900 to +900), Fifth Parameter = Set Slit X-axis (0.00 to 2500 microns, depends on magnification), Sixth Parameter = Set Slit Y-axis (0.00 to 2500 microns, depends on magnification), LS? returns current settings.
PM # PM?	Mode. Sets the laser firing mode, 0 = continuous, 1 = single shot, 2 = burst. (Default: 0). A query returns the currently set mode.
QE # QE?	Qswitch Enable. Enables normal Qswitch operation. 0 – Disables normal operation, 1 – Enables normal operation.
RR ## RR?	Repetition Rate. This sets the rate at which the laser will fire at. Values are from 1-40 Hz. (Default: 10 Hz). A query will return the current rate.
SC?	Shot Count. Queries the laser accumulated shot count.
SW # SW?	Select Wavelength. Selects the wavelength to control. Range is 1 to 4 where 1 = IR, 2 = GRN, 3 = UV, 4 = DUV. A query returns the current wavelength being controlled. NOTE: The system will only have two available wavelengths.
SA # SA?	Slit Rotation. Sets the current slit rotation angle. Range is from +45 to -45 degrees. A plus or minus is required to determine angle. (Default: 0). Parameter = degrees*10 (+450 to -450). A query returns the current rotation angle.
SY # SY?	Sync Output Mode. 0 = Off, 1 = LD Pulse, 2 = QSW Pulse, 3 = LD/QSW, 4 = Emission
SP #,##.##,##.## SP?	Slit Position. First Parameter is Magnification. Sets the current slit X and Y blade position. Values are from 0.00 to 2500 microns for both axes depending on magnification. Actual allowed range depends on the objective magnification. Slit range is 0 to 2.5mm, thus the image size range is 0 to 2500/magnification. A query returns the current cut size.
UC 0 UC?	User Count. This is a user re-settable shot counter. It is a saved count and can be cleared by issuing a 0 parameter following the command.

Illuminator Commands

IL #,####	Illuminator level. First parameter is the illuminator channel. 1 = Slit backlight. The second parameter is the intensity level 0 to 1000. Status returns level for both illuminators. NOTE: The LS635B system does not have a Coax light connected.
-----------	---

Calibration Commands

ECS #,# ECS?	Energy Calibration Setup. Configures the system for energy calibration. First parameter is the wavelength, second parameter is High/Low energy mode. Output energy will automatically be set to 50% of maximum available.
ECM # ECM?	Energy Calibration Maximum. Stores the 50% maximum energy out of the system for the current wavelength and power level as measured with the ECS command settings. NOTE: A value should be stored for both High and Low energy modes. Store value immediately after measuring without changing any other settings.
ECF #,# ECF?	Energy Calibration Full scale. Sets the desired full scale energy output for the selected wavelength - High mode. First parameter is the WL and the second is the desired 100% High-mode output energy. A query returns both high and low values for the current wavelength. High, Low. NOTE: The low value scale is automatically set to 25% of High-mode.
ECR	Energy Calibration Reset. Resets values to defaults for all wavelengths.

9. Maintenance

The LS-635B system is designed to be maintenance free and should provide many hours of operation before any maintenance is required. There are no user serviceable parts inside the system nor is there any periodic service required. In the event that the system is not performing to specification, please contact the factory for service.

10. Trouble-Shooting

The LS-635B control electronics are designed to control the laser and warn the user of problems that may occur. The microprocessor-based system monitors the laser system and automatically shuts down if a fault occurs. Software limits have been factory selected to protect the laser system against electrical and optical damage.

No Laser Output

Check Fault and Interlock Conditions: Query status information using commands listed in the command set. Refer to status to determine if a fault or interlock conditions exists.

Check Cables: With the main power OFF and unplugged, check all electrical connections between the Laser Optics Assembly and the Laser Power Supply. Make sure all connections are secured. If any of the cables are not installed properly, the system will not function.

Check Energy Setting: Check to see that the Maximum energy (ECM) setting is not set lower than the Full Scale energy (ECF). Correct if necessary.

Check Q-Switch Settings: Verify that the Q-Switch is enabled.

Energy is Low

Laser is not warmed up: Be sure to allow the laser to properly warm up a minimum of 10 minutes before operation.

Attenuator is set too low: Verify that the attenuator is set to a percentage that lets sufficient energy through the system.

Filter wheel is in low mode. Verify that the high/low mode is set to a high mode unless a low energy range is desired.

System miss-alignment: The beam path through the system may be misaligned. Contact manufacturer for more details.

Resonator Misaligned: If beam quality has degraded, it may suggest that the resonator needs realignment. Contact manufacturer for more details.

Contact the manufacturer for any repair actions necessary beyond those described in this manual. Attempts to adjust, repair or replace any portion of the laser system may cause additional problems and void the warranty.

11. Specifications

LS-635B

Laser

Specifications

Specification

Notes

Jewel Laser		Sealed, conductively cooled resonator integrated with drive and control electronics.
Wavelength	Two wavelengths (1064/532, 532/355, or 532/266)	Beam selection and energy control using filter wheel and dual wavelength attenuator.
Rep Rate	1-20Hz Nominal 21-50Hz (1)	
Energy per Pulse (Typical)		
1064 nm	≥ 1.2 mJ	Energy is specified at the output of the LS-635B system and does not include losses from customer supplied optics. If required energy specification can be increased.
532 nm	≥ 1.2 mJ	
355 nm	≥ 0.4 mJ	
266 nm	≥ 0.4 mJ	
Pulse Width		
1064 nm	≤ 12 ns	Full width half maximum
532 nm	≤ 11 ns	
355 nm	≤ 10 ns	
266 nm	≤ 10 ns	
Pulse to Pulse Stability		
		full aperture 50% 25% 10%
1064 nm	≤3.0% ≤3.5% ≤4.0% ≤6.0%	RMS pulse-to-pulse stability for 98% of pulses after warm-up, with a 100 shot sample window
532 nm	≤3.5% ≤4.0% ≤4.5% ≤6.5%	
355 nm	≤4.0% ≤5.0% ≤6.0% ≤8.0%	
266 nm	≤4.0% ≤5.0% ≤6.0% ≤8.0%	
Diode Lifetime		> 500,000,000 pulses

Attenuator

Specifications

Specification

Notes

Attenuation Range	0 to 100%	Attenuator is calibrated and linearized to provide the specified energy.
Accuracy	±0.5%	
Resolution	0.20%	
Tact Time	≤ 1.0 s	Full range of travel.
Initialization	≤ 6.0 s	From power-up.

X-Y Slit	Specification	Notes
Range	0 to 2.5 mm 0 to 4 mm (optional)	0 to 50 μ m with 50x objective
Accuracy	$\pm(25 \mu\text{m} + 0.01 * \text{size})$	
Resolution	25 μ m	0.5 μ m with 50x objective
Tact Time	≤ 1.0 s	Full range of travel.
Initialization	≤ 6.0 s	From power-up.

Theta Slit	Specification	Notes
Rotation Range	-45 to +45 degrees	
Accuracy	± 1.0 degree	
Resolution	0.5 degrees	
Tact Time	≤ 1.0 s	Full range of travel.
Initialization	≤ 6.0 s	From power-up.

Filter Wheel	Specification	Notes
Positions	4	
Tact Time	≤ 1.0 s	Full range of travel.
Initialization	≤ 6.0 s	From power-up.

1. Proper heat sinking required. Long term drift may exceed specifications. Contact factory for details.

System	Specification	Notes
Size		
Payload	81 mm x 194 mm x 298 mm	
Power Supply	3.5, 19" Rack Mount.	2U Rack Mount
Weight		
Payload	5.5 kg	
Power Supply	≤ 4.5 kg	
Operating Voltage(1)	100 - 240 VAC, 50/60 Hz	
Operating Power	< 100 Watts < 5 Amps (FLA)	
Fusing	6.3A, 250VAC, 5mm x 20mm Slow Blow	
Computer Interface		
Standard	RS-232	
Notes	The length of umbilical cable to interface from laser head to power supply will need to be specified at the time of order.	

1. Only the power supply cord supplied with the Equipment or an Approved equivalently rated cord suitable for this application shall be used.

12. Cables and Connection Pinout

Umbilical Cable

Control Cable

Connector on Power supply side is Norcomp Inc. 171-025-103L001 or Equivalent

Connector on LS-635B Payload side is Norcomp Inc. 172-E25-203R001 or Equivalent

Signal	Pin (Cable is 1:1)	Recommended AWG
System Power (+36 VDC)	1,2	>=24 AWG
System Ground	14,15	>=24 AWG
Spare Signals	3,16	>=24 AWG
Status 1 (Ground)	5 (18)	>=24 AWG
Status 2 (Ground)	4 (17)	>=24 AWG
Interlock (Ground)	6 (19)	>=24 AWG
EMO Switch (Ground)	7 (20)	>=24 AWG
Sync (Ground)	8 (21)	>=24 AWG
Trigger 1 (Ground)	10 (23)	>=24 AWG
Trigger 2 (Ground)	9 (22)	>=24 AWG
RS-232 RTS	11	>=24 AWG
RS-232 CTS	24	>=24 AWG
RS-232 RX	12	>=24 AWG
RS-232 Ground	25	>=24 AWG
RS-232 Tx	13	>=24 AWG
Notes:	<ol style="list-style-type: none">1. Shield should encompass all wires and connect to both hoods2. Group power wires3. Group RS-232 wires4. Group others as shown	

13. Customer Service

Warranty

The manufacturer warrants the lasers it produces to be free from defects in materials and workmanship for one year following the date of shipment. Laser optics are warranted for 90 days following the date of shipment provided that operating instructions are properly followed. This warranty is limited to the original purchaser of the laser and is not transferable.

During the one year warranty period, we will repair or replace, at our option, any defective products or parts at no additional charge, provided that the product is returned, shipping prepaid, to Quantum Composers. All replaced parts and products become the property of the manufacturer.

This warranty does NOT extend to any lasers which have been damaged as a result of accident, misuse, abuse (such as use of incorrect input voltages, improper or insufficient ventilation, failure to follow the operating instructions provided by the manufacturer, or other contingencies beyond our control), or as a result of service or modification by anyone other than the manufacturer.

Feedback

We welcome your feedback in regard to the use and performance of our laser system. Product improvements and refinements come about from these contacts; continually improve our product reliability, performance and customer satisfaction.

14. Appendix A - Fuse Replacement

In the event that the fuse needs replacement, the following steps should be performed.

1. Unplug the AC mains power cord from the power supply.
2. Remove the fuse tray by inserting a flat blade screwdriver and gently prying the drawer open.



3. Pull the drawer open.



4. Remove the fuse and replace with a fuse with the following specifications: 6.3A, 250VAC, 5mm x 20mm Slow Blow.