

PMW3389DM-T3QU: Optical Gaming Navigation Chip

General Description

PMW3389DM-T3QU is PixArt Imaging's high end corded gaming navigation chip with illumination source in a 16pin molded lead-frame DIP package. It provides best in class gaming experience with the enhanced features of high speed, high resolution, high accuracy and selectable lift detection height to fulfill professional gamers' need. It is designed to be used with LM19-LSI lens to achieve optimum performance.

Key Features

- 16 pin molded lead-frame DIP package with 850nm illumination source.
- Enhanced programmability
 - Lift detection options
 - Manual lift cut off calibration
 - 2mm or 3mm setting
 - Selectable resolutions up to 16000CPI with 50CPI step size
 - Angle snapping
 - Angle tunability
- Resolution error of 1% (typical) at 5000CPI up to 200ips.
- High speed motion detection 400ips (typical) and acceleration 50g (max).
- Self –adjusting variable frame rate for optimum performance
- Internal oscillator — no clock input needed
- Four wire serial port interface (SPI)
- Motion interrupt output

Applications

- Wired Optical gaming mice
- Integrated input devices

Key Parameters

Parameter	Value
Power supply Range	VDD: 1.8V - 2.1V VDDIO: 1.8V - 3.6V
Lens Magnification	1:1
Interface	4 wire Serial Port Interface (SPI)
Typical Operating Current @ VDD = 1.9V Note: includes LED current	Run: 21mA Rest1: 3.1mA Rest2: 0.06mA Rest3: 0.03mA Power Down: 10uA
Resolution (cpi)	Up to 16000
Tracking Speed (ips)	400 (typical)
Acceleration (g)	50 (max)
Package Size (mm)	10.90x16.20x5.01

Ordering Information:

Part Number	Package Type
PMW3389DM-T3QU	16pin-DIP
LM19-LSI	Lens

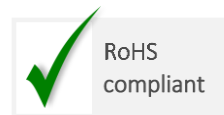

For any additional inquiries, please contact us at <http://www.pixart.com/contact.asp>

Table of Contents

PMW3389DM-T3QU: Optical Gaming Navigation Chip 1

 General Description 1

 Key Features..... 1

 Applications..... 1

 Key Parameters..... 1

 Ordering Information: 1

List of Figures 3

List of Tables..... 3

1.0 Introduction..... 4

 1.1 Chip Overview 4

 1.2 Pin Configuration 5

2.0 Mechanical Specifications..... 6

 2.1 Chip Package Dimension 6

 2.2 Package Marking..... 6

 2.3 Chip Assembly Drawings..... 7

 2.4 Lens Dimensions 10

 2.5 Lens Assembly Drawings 11

 2.6 PCB Assembly Recommendations..... 13

3.0 Reference Schematics14

4.0 Electrical Specifications15

 4.1 Regulatory Requirements..... 15

 4.2 Absolute Maximum Ratings 15

 4.3 Recommended Operating Conditions 15

 4.4 AC Electrical Specifications..... 16

 4.5 DC Electrical Specifications..... 18

5.0 Registers.....20

 5.1 Registers Summary Table 20

List of Figures

Figure 1. Block Diagram..... 4
 Figure 2. Device Pinout 5
 Figure 3. Packages Outline Drawing 6
 Figure 4. Recommended Chip Orientation, Mechanical Cutouts and Spacing (Top View) 7
 Figure 5. Assembly Drawing of PMW3389DM-T3QU and Distance from Lens Reference Plane To Tracking Surface (Z)..... 8
 Figure 6. Exploded View of Assembly..... 9
 Figure 7. LM19-LSI Lens Outline Drawing 10
 Figure 8. Cross Section View of Lens Assembly 11
 Figure 9. Recommended Base Plate Opening..... 12
 Figure 10. Reference Schematic diagram for PMW3389DM-T3QU 14
 Figure 11. Mean Resolution vs. Z Height at resolution of 5000cpi 19
 Figure 12. Path Error vs. Z Height at resolution of 5000cpi 19

List of Tables

Table 1. Pin Definition 5
 Table 2. Package Marking Description 6
 Table 3. Absolute Maximum Ratings 15
 Table 4. Recommended Operating Condition 15
 Table 5. AC Electrical Specifications 16
 Table 6. DC Electrical Specifications 18

1.0 Introduction

1.1 Chip Overview

The PMW3389DM is an optical navigation chip targeted for high-end corded gaming mouse. It contains a picture element array as Image Acquisition System (IAS), a Digital Signal Processor (DSP), a four wire serial port, a power control circuit and built-in LED driver integrated with IR LED in a package as shown in the block diagram. The chip measures changes in position by optically acquiring sequential surface images (frames) and mathematically determining the direction and magnitude of movement. The IAS acquires microscopic surface images via the lens and illumination system. These images are processed by the DSP to determine the direction and distance of motion. The DSP calculates the Δx and Δy relative displacement values. An external microcontroller reads the Δx and Δy information from the chip serial port. The microcontroller then translates the data into USB, or RF signals before sending them to the host PC or game console.

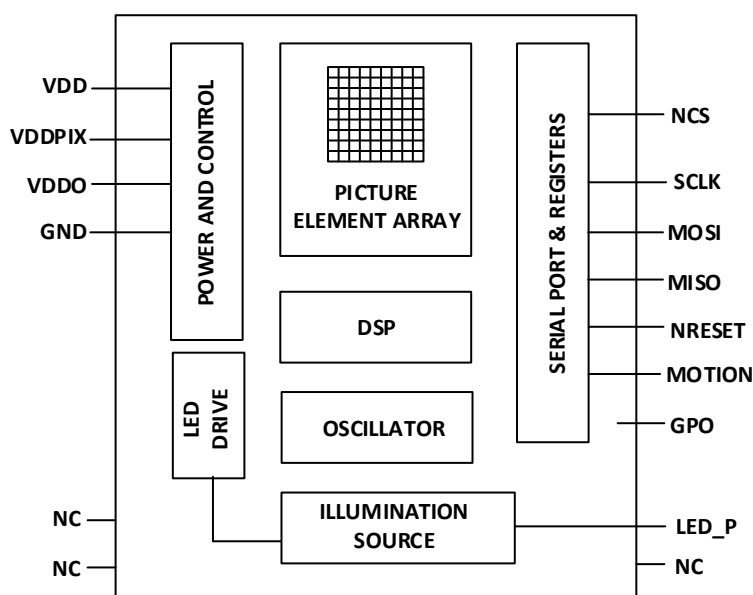

Figure 1. Block Diagram

1.2 Pin Configuration

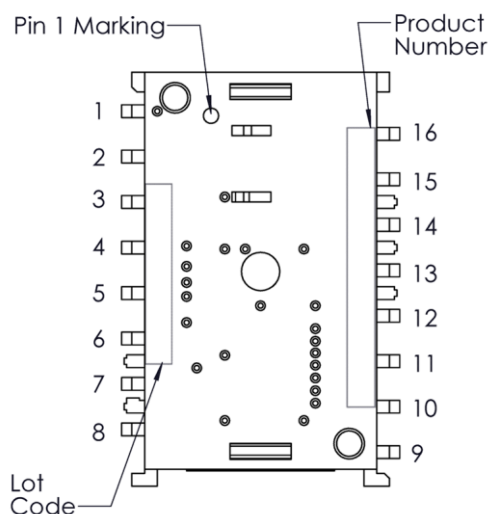

Figure 2. Device Pinout

Table 1. Pin Definition

Pin No.	Function	Symbol	Type	Description
1	Reserved	NC	NC	No connection
2	Reserved	NC	NC	No connection
3	Supply Voltage and I/O Voltage	VDCPIX	Power	LDO output for selective analog circuit
4		VDD	Power	Input power supply
5		VDDIO	Power	I/O reference voltage
6	General Purpose Output	GPO	Output	General Purpose Output
7	Reset Control	NRESET	Input	Chip reset (Active Low)
8	Ground	GND	GND	Ground
9	Motion Output	MOTION	Output	Motion detect
10	4-wire SPI	SCLK	Input	Serial data clock
11		MOSI	Input	Serial data input
12		MISO	Output	Serial data output
13		NCS	Input	Chip select (Active Low)
14	Reserved	NC	NC	No connection
15	LED	LED_P	Input	LED Anode
16	Reserved	NC	NC	No connection

2.0 Mechanical Specifications

This section covers PMW3389’s guidelines and recommendations in term of chip, lens & PCB assemblies.

2.1 Chip Package Dimension

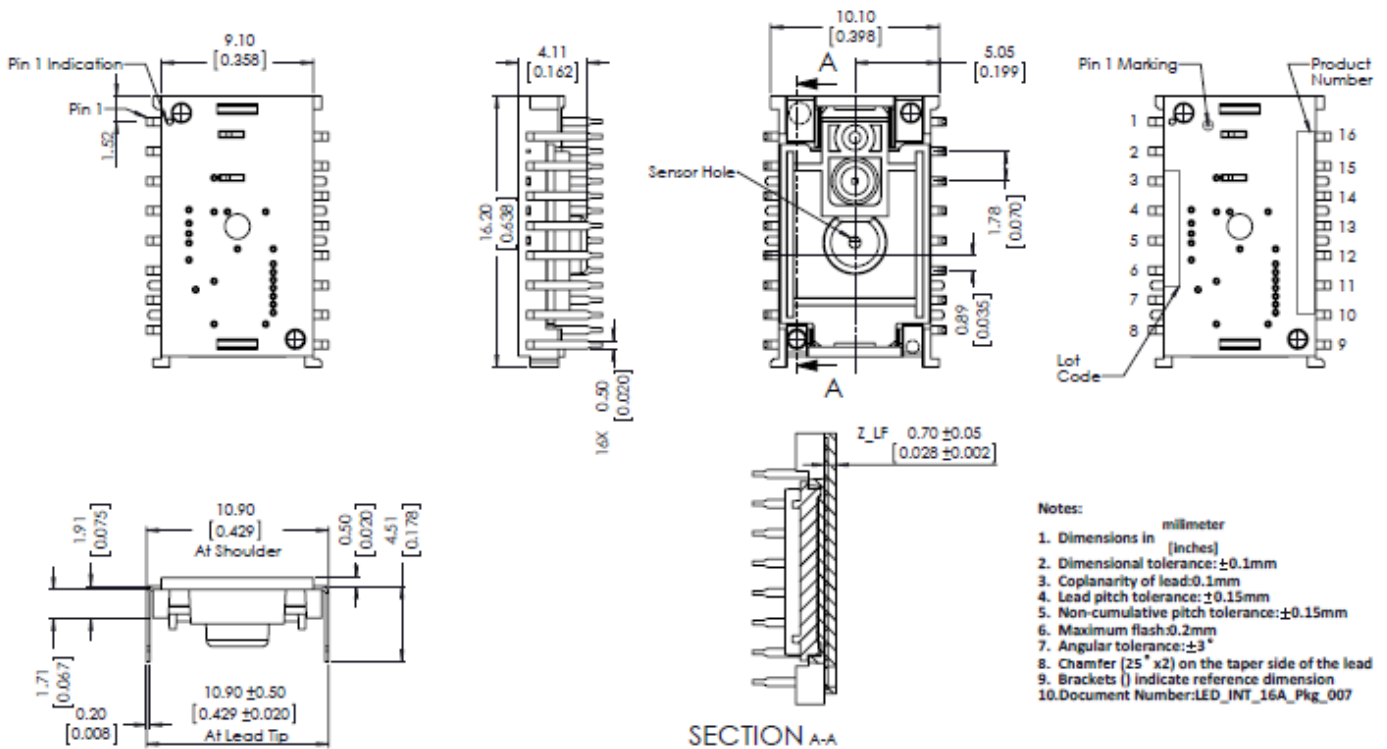

Figure 3. Packages Outline Drawing

CAUTION: It is advised that normal static discharge precautions be taken in handling and assembling of this component to prevent damage and/or degradation which may be induced by ESD.

2.2 Package Marking

Table 2. Package Marking Description

Items	Marking	Remark
Product Number	PMW3389DM-T3QU	
Lot Code	AYWWXXXXX	A : Assembly house Y: Year WW: Week XXXXX: PixArt reference

2.3 Chip Assembly Drawings

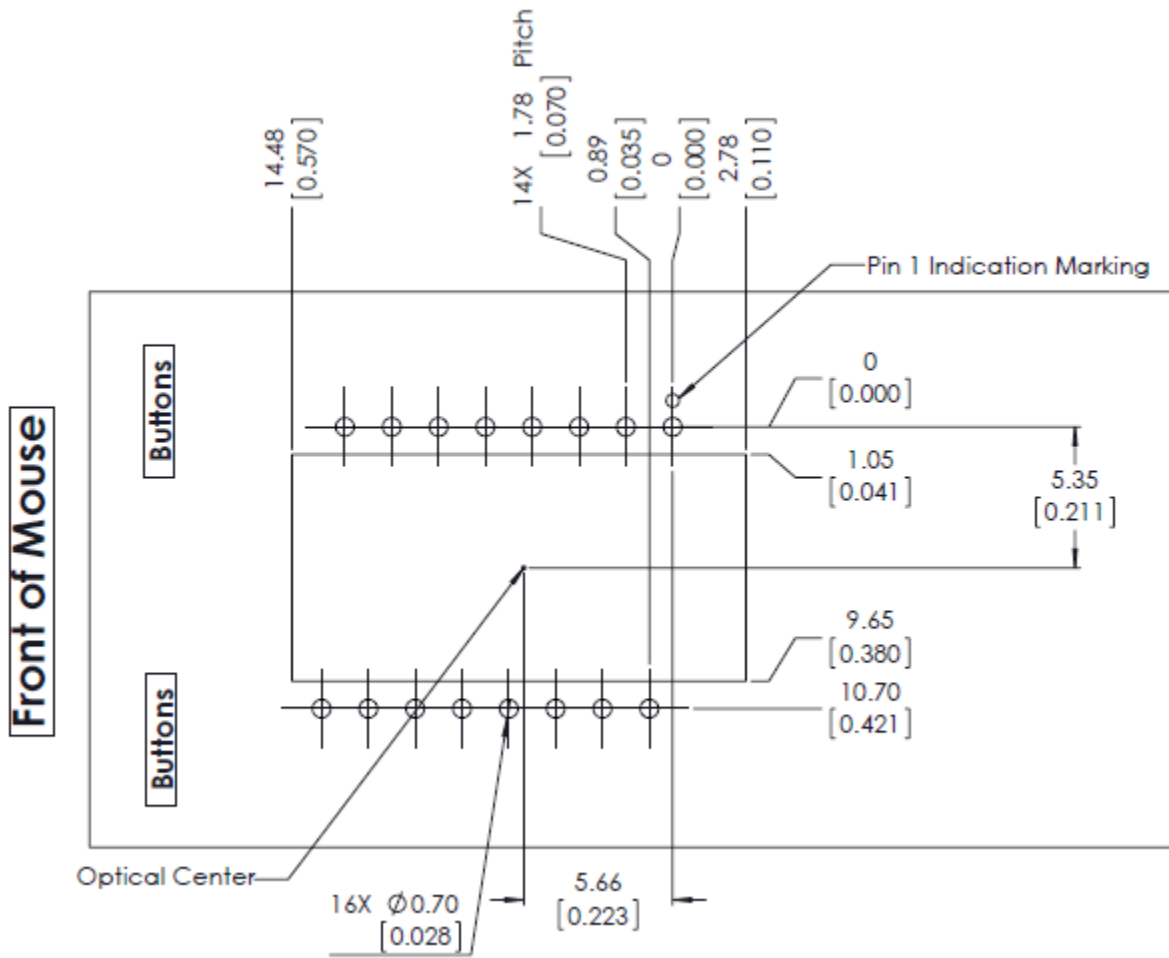

Figure 4. Recommended Chip Orientation, Mechanical Cutouts and Spacing (Top View)

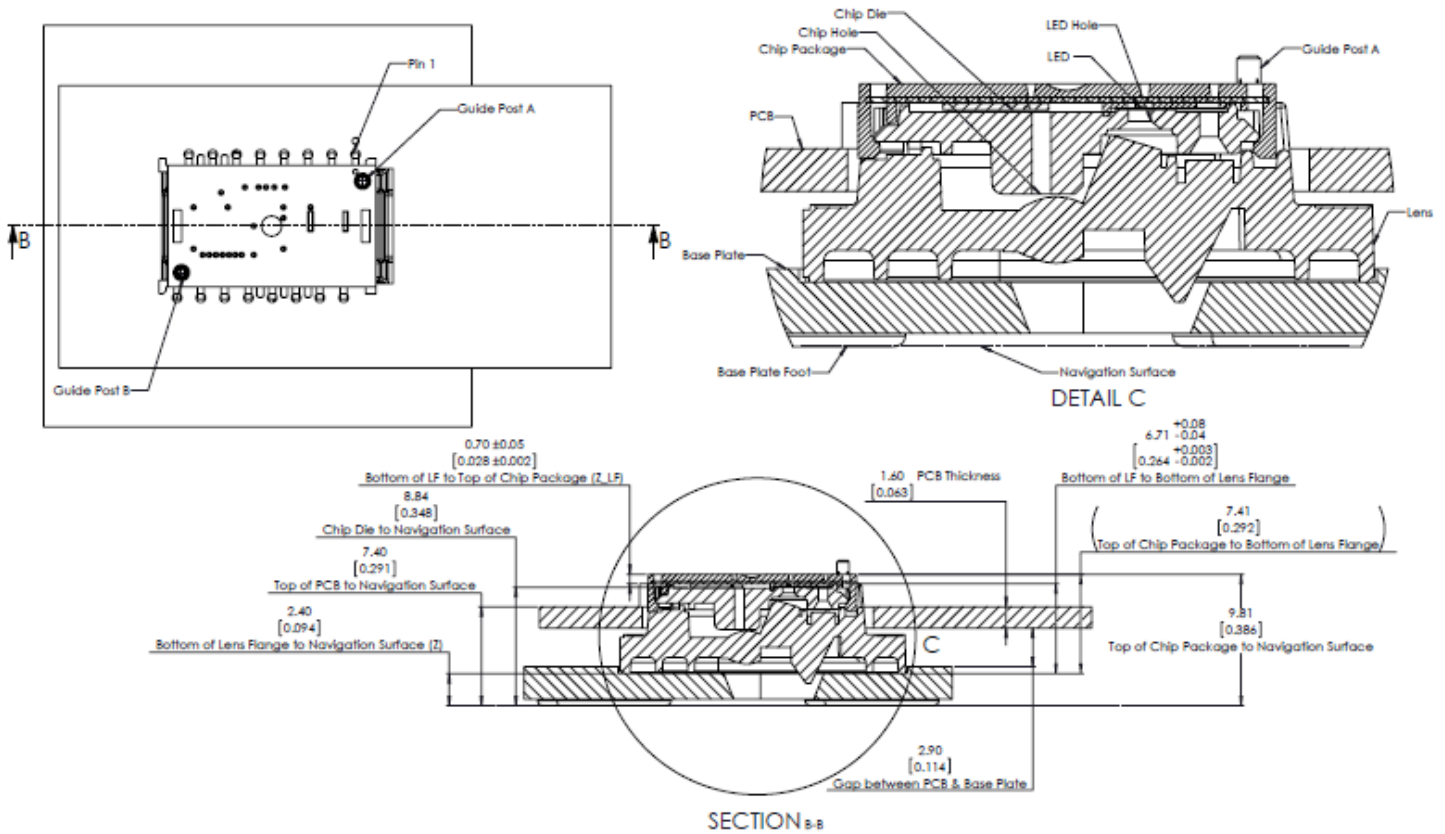

Figure 5. Assembly Drawing of PMW3389DM-T3QU and Distance from Lens Reference Plane To Tracking Surface (Z)

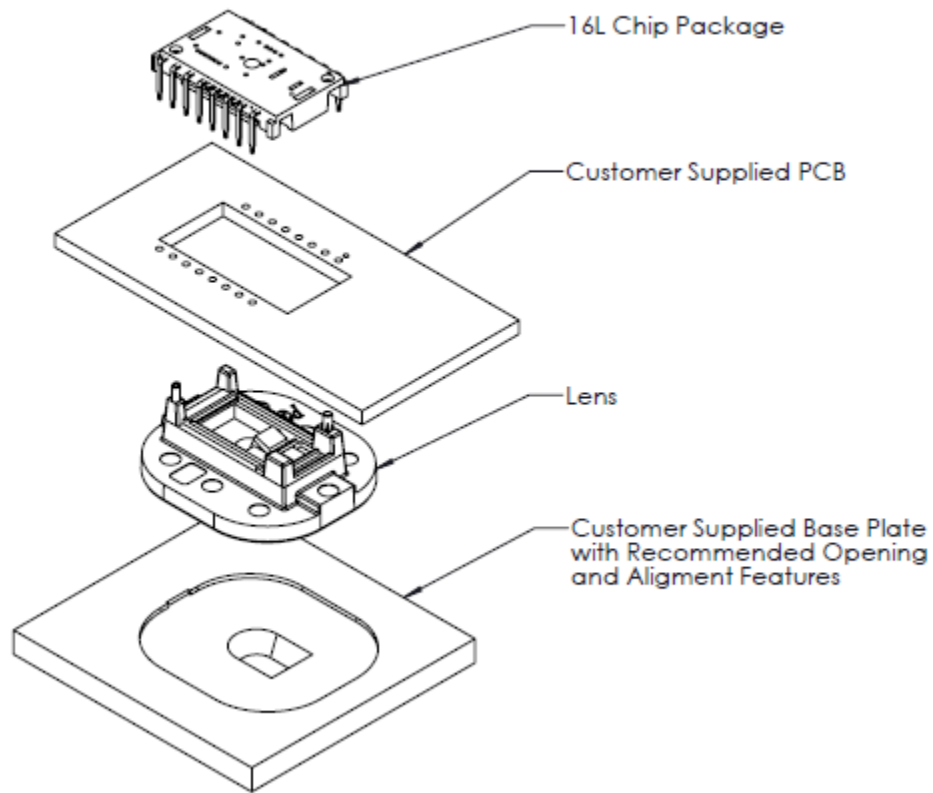
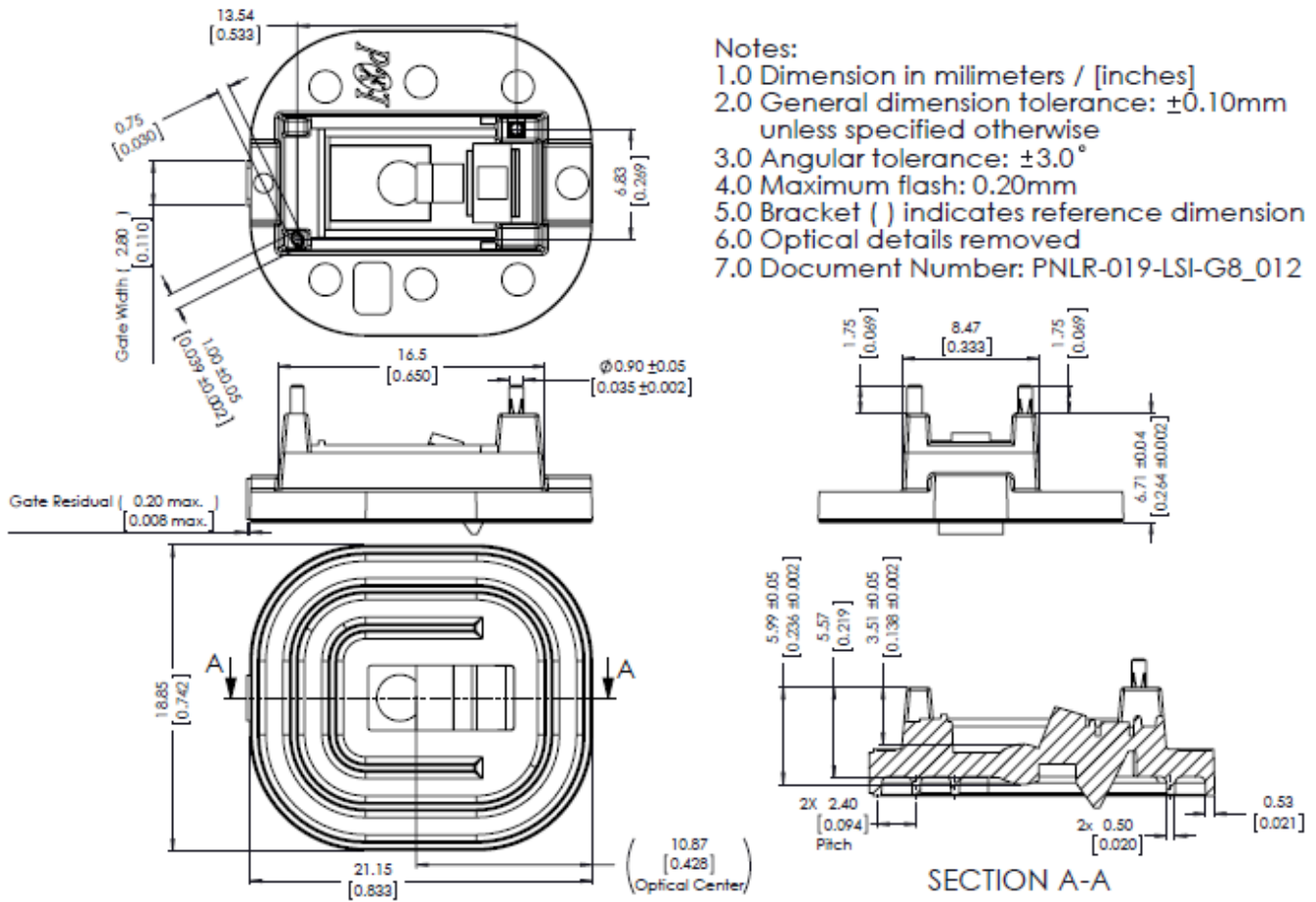

Figure 6. Exploded View of Assembly

2.4 Lens Dimensions



- Notes:
- 1.0 Dimension in millimeters / [inches]
 - 2.0 General dimension tolerance: ± 0.10 mm unless specified otherwise
 - 3.0 Angular tolerance: $\pm 3.0^\circ$
 - 4.0 Maximum flash: 0.20mm
 - 5.0 Bracket () indicates reference dimension
 - 6.0 Optical details removed
 - 7.0 Document Number: PNLR-019-LSI-G8_012

Figure 7. LM19-LSI Lens Outline Drawing

2.5 Lens Assembly Drawings

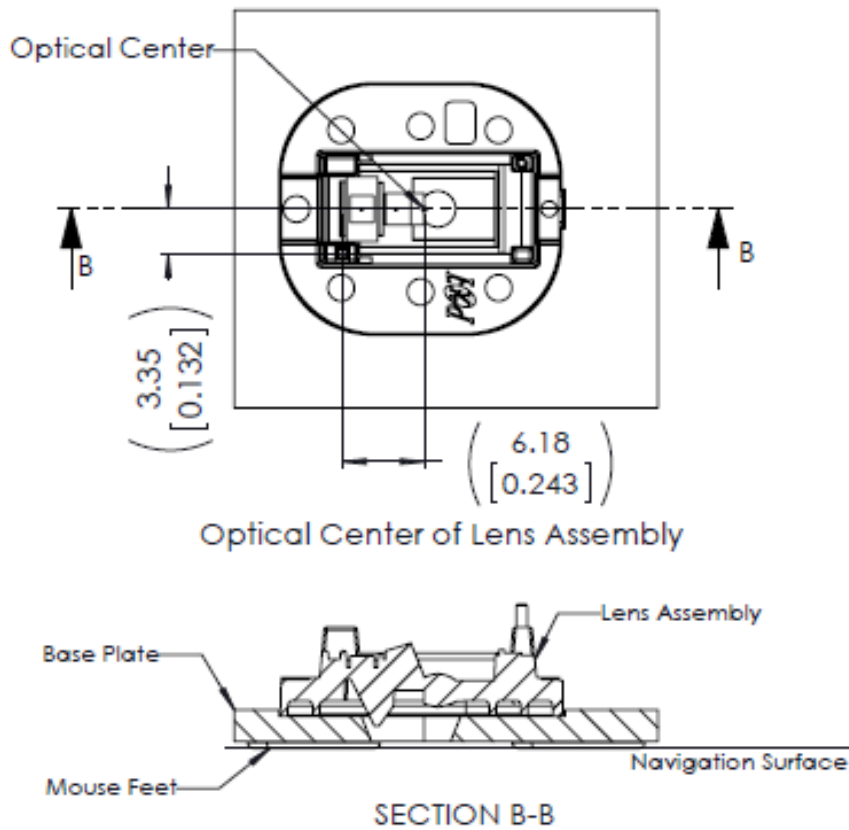

Figure 8. Cross Section View of Lens Assembly

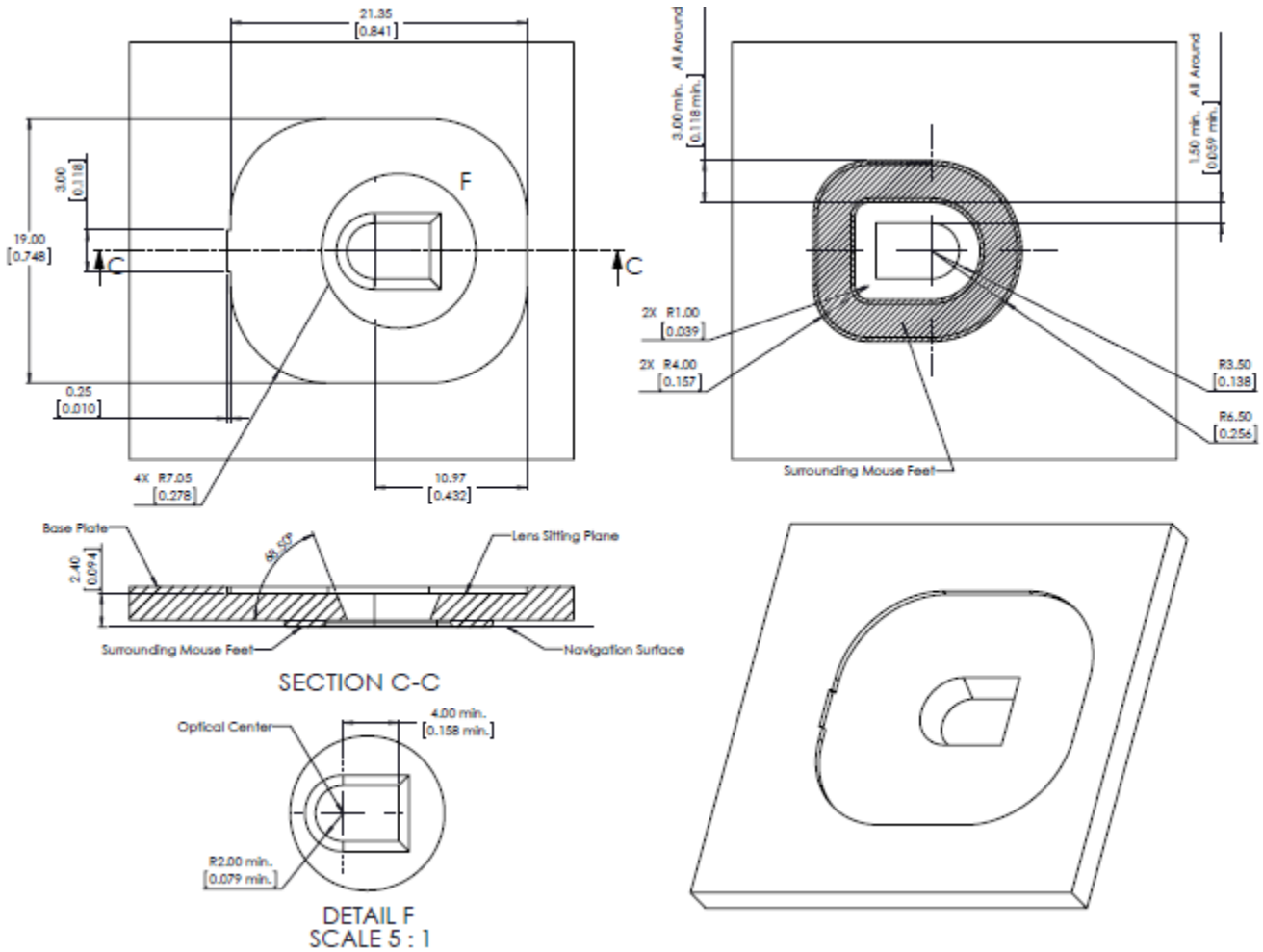

Figure 9. Recommended Base Plate Opening

Note: Mouse feet should be placed close to the optical opening to stabilize the surface within the FOV of the chip.

2.6 PCB Assembly Recommendations

1. Insert the integrated chip and all other electrical components into PCB.
2. Wave-solder the entire assembly in a no-wash solder process utilizing solder-fixture. A solder-fixture is required to protect the chip from flux spray and wave solder paste.
3. Avoid getting any solder flux onto the chip body as there is potential for flux to seep into the chip package, the solder fixture should be designed to expose only the chip leads to flux spray & molten solder while shielding the chip body and optical apertures. The fixture should also set the chip at the correct position and height on the PCB.
4. Place the lens onto the base plate. Care must be taken to avoid contamination on the optical surfaces.
5. Remove the protective kapton tapes from optical apertures of the chip. Care must be taken to prevent Contaminants from entering the apertures. Do not place the PCB with the chip facing up during the entire mouse assembly process. Hold the PCB vertically when removing kapton tape.
6. Insert PCB assembly over the lens onto the base plate aligning post to retain PCB assembly. The chip package will self-align to the lens via the guide posts. The optical position reference for the PCB is set by the base plate and lens. Note that the PCB motion due to button presses must be minimized to maintain optical alignment.
7. **Recommendation:** The lens can be permanently secured to the chip package by melting the lens' guide posts over the chip with heat staking process. Please refer to Application Note titled "*LM19-LSI Lens: PCB Assembly & Lens Heat Staking Recommendations*" for details and recommendation on the lens heat staking process.
8. Install mouse top case. There must be a feature in the top case to press down onto the PCB assembly to ensure all components are stacked or interlocked to the correct vertical height.
9. Recommended to place mouse feet around the base plate opening to be stabilized on the tracking surface.

3.0 Reference Schematics

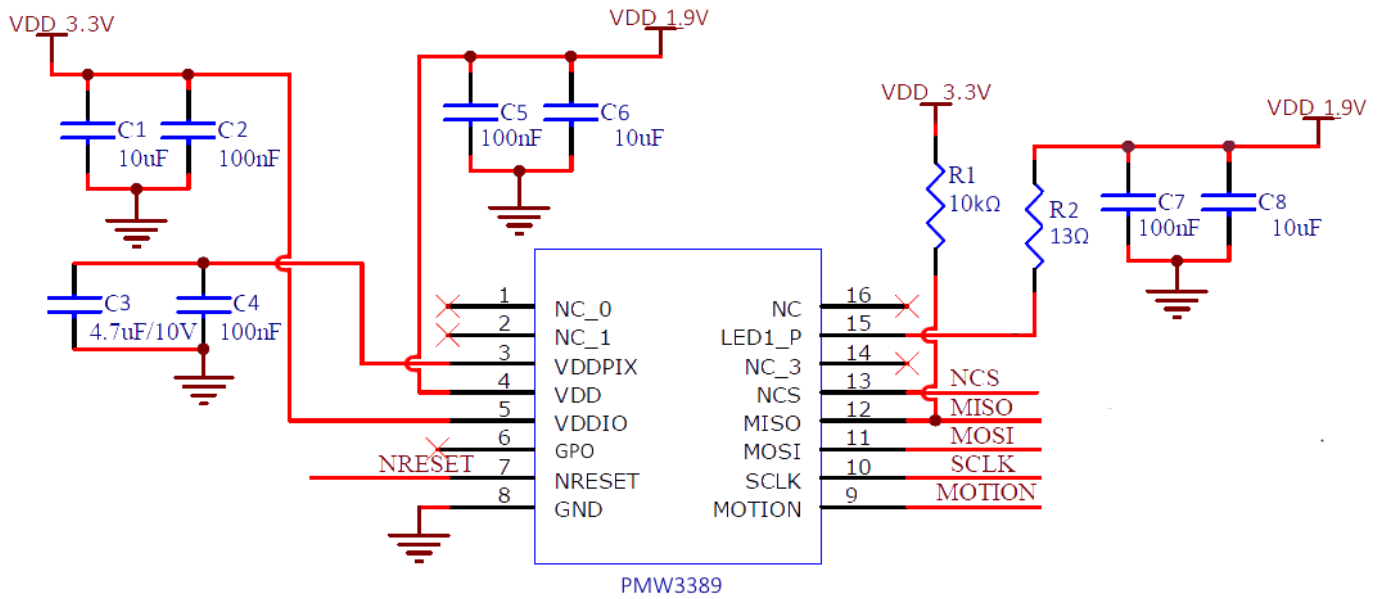

Figure 10. Reference Schematic diagram for PMW3389DM-T3QU

4.0 Electrical Specifications

4.1 Regulatory Requirements

- Passes FCC “Part15, Subpart B, Class B”, “CISPR 22 1997 Class B” and worldwide analogous emission limits when assembled into a mouse with shielded USB cable using ferrite bead and following PixArt’s recommendations.
- Passes IEC 62471: 2006 Photo biological safety of lamps and lamp systems

4.2 Absolute Maximum Ratings

Table 3. Absolute Maximum Ratings

Parameter	Symbol	Min	Max	Units	Notes
Storage Temperature	T_S	-40	85	°C	
Lead Solder Temperature	T_{SOLDER}		260	°C	For 7 seconds, 1.6mm below seating
Supply Voltage	V_{DD}	-0.5	2.10	V	
	V_{DDIO}	-0.5	3.60	V	
ESD	ESD_{HBM}		2	kV	Human Body Model on All pins
Input Voltage	V_{IN}	-0.5	3.6	V	All I/O pins.

4.3 Recommended Operating Conditions

Table 4. Recommended Operating Condition

Parameter	Symbol	Min	Typ.	Max	Units	Notes
Operating Temperature	T_A	0		40	°C	
Power Supply Voltage	V_{DD}	1.80	1.90	2.10	V	Excluding supply noise
	V_{DDIO}	1.80	1.90	3.60	V	Excluding supply noise. (V_{DDIO} must be same or greater than V_{DD})
Power Supply Rise Time	t_{RT}	0.15		20	ms	0 to V_{DD} min
Supply Noise (Sinusoidal)	V_{NA}			100	mVp-p	10 kHz — 75 MHz
Serial Port Clock Frequency	f_{SCLK}			2.0	MHz	50% duty cycle
Distance from Lens Reference Plane to Tracking Surface	Z	2.2	2.4	2.6	mm	
Speed	S		400		ips	
Resolution Error	Res_{Err}		1		%	Up to 200ips on QCK at 5000 CPI
Acceleration	A			50	g	In run mode
Lift Cutoff 2mm setting	$Lift_{2mm}$		2		mm	PixArt Standard Gaming Surfaces
Lift Cutoff 3mm setting	$Lift_{3mm}$		3		mm	PixArt Standard Gaming Surfaces

4.4 AC Electrical Specifications

Table 5. AC Electrical Specifications

Chip electrical characteristics over recommended operating conditions. Typical values at 25°C, $V_{DD} = 1.9V$, $V_{DDIO} = 1.9V$

Parameter	Symbol	Min	Typical	Max	Units	Notes
Motion Delay After Reset	$t_{MOT-RST}$	50			ms	From reset to valid motion, assuming motion is present
Shutdown	t_{STDWN}			500	μs	From Shutdown mode active to low current
Wake From Shutdown	t_{WAKEUP}	50			ms	From Shutdown mode inactive to valid motion. Notes: A RESET must be asserted after a shutdown. Refer to section "Notes on Shutdown", also note $t_{MOT-RST}$
MISO Rise Time	t_{r-MISO}		50		ns	$C_L = 100pF$
MISO Fall Time	t_{f-MISO}		50		ns	$C_L = 100pF$
MISO Delay After SCLK	$t_{DLY-MISO}$			90	ns	From SCLK falling edge to MISO data valid, no load conditions
MISO Hold Time	$t_{hold-MISO}$	200			ns	Data held until next falling SCLK edge
MOSI Hold Time	$t_{hold-MOSI}$	200			ns	Amount of time data is valid after SCLK rising edge
MOSI Setup Time	$t_{setup-MOSI}$	120			ns	From data valid to SCLK rising edge
SPI Time Between Write Commands	t_{SWW}	180			μs	From rising SCLK for last bit of the first data byte, to rising SCLK for last bit of the second data byte.
SPI Time Between Write And Read Commands	t_{SWR}	180			μs	From rising SCLK for last bit of the first data byte, to rising SCLK for last bit of the second address byte.
SPI Time Between Read And Subsequent Commands	t_{SRW} t_{SRR}	20			μs	From rising SCLK for last bit of the first data byte, to falling SCLK for the first bit of the address byte of the next command.
SPI Read Address-Data Delay	t_{SRAD}	160			μs	From rising SCLK for last bit of the address byte, to falling SCLK for first bit of data being read.
SPI Read Address-Data Delay for Burst Mode Motion Read	t_{SRAD_MO} TBR	35			μs	From rising SCLK for last bit of the address byte, to falling SCLK for first bit of data being read. Applicable for Burst Mode Motion Read only.
NCS Inactive After Motion Burst	t_{BEXIT}	500			ns	Minimum NCS inactive time after motion burst before next SPI usage

Parameter	Symbol	Min	Typical	Max	Units	Notes
NCS To SCLK Active	$t_{\text{NCS-SCLK}}$	120			ns	From last NCS falling edge to first SCLK rising edge
SCLK To NCS Inactive (For Read Operation)	$t_{\text{SCLK-NCS}}$	120			ns	From last SCLK rising edge to NCS rising edge, for valid MISO data transfer
SCLK To NCS Inactive (For Write Operation)	$t_{\text{SCLK-NCS}}$	35			μs	From last SCLK rising edge to NCS rising edge, for valid MOSI data transfer
NCS To MISO High-Z	$t_{\text{NCS-MISO}}$			500	ns	From NCS rising edge to MISO high-Z state
MOTION Rise Time	$t_{\text{r-MOTION}}$		50		ns	$C_L = 100\text{pF}$
MOTION Fall Time	$t_{\text{f-MOTION}}$		50		ns	$C_L = 100\text{pF}$
GPO Rise Time	$t_{\text{r-GPO}}$		50			$C_L = 100\text{pF}$
GPO Fall Time	$t_{\text{f-GPO}}$		50			$C_L = 100\text{pF}$
Input Capacitance	C_{in}		50		pF	SCLK, MOSI, NCS
Load Capacitance	C_L			100	pF	MISO, MOTION, GPO
Transient Supply Current	I_{DDT}			70	mA	Max supply current during the supply ramp from 0V to V_{DD} with min 150 us and max 20ms rise time. (Does not include charging currents for bypass capacitors)
	I_{DDTIO}			60	mA	Max supply current during the supply ramp from 0V to V_{DDIO} with min 150 us and max 20ms rise time. (Does not include charging currents for bypass capacitors)

4.5 DC Electrical Specifications

Table 6. DC Electrical Specifications

Chip electrical characteristics over recommended operating conditions. Typical values at 25°C, $V_{DD} = 1.9V$, $V_{DDIO} = 1.9V$, and with LED current at 26mA.

Parameter	Symbol	Min	Typ.	Max	Units	Notes
DC Supply Current	$I_{DD_{RUN}}$		21.0		mA	$I_{DD_{RUN}}$: Average current consumption, including LED current with 1ms polling
	$I_{DD_{REST1}}$		3.1			
	$I_{DD_{REST2}}$		0.06			
	$I_{DD_{REST3}}$		0.03			
Shutdown Current	I_{PD}		10.0		μA	
Input Low Voltage	V_{IL}			$0.3 * V_{DDIO}$	V	SCLK, MOSI, NCS
Input High Voltage	V_{IH}	$0.7 * V_{DDIO}$			V	SCLK, MOSI, NCS
Input Hysteresis	V_{I_HYS}		100		mV	SCLK, MOSI, NCS
Input Leakage Current	I_{leak}		± 1	± 10	μA	$V_{in} = V_{DDIO}$ or 0V, SCLK, MOSI, NCS
Output Low Voltage	V_{OL}			0.45	V	$I_{out} = 1mA$, MISO, MOTION, GPOre
Output High Voltage	V_{OH}	$V_{DDIO} - 0.45$			V	$I_{out} = -1mA$, MISO, MOTION, GPO

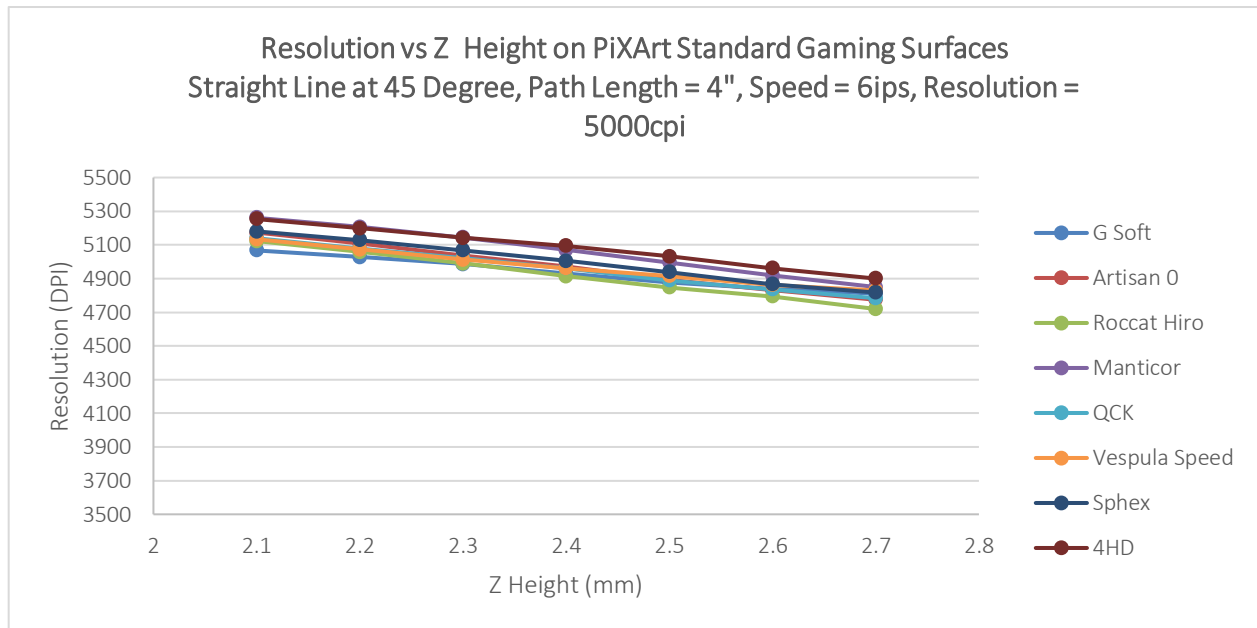

Figure 11. Mean Resolution vs. Z Height at resolution of 5000dpi

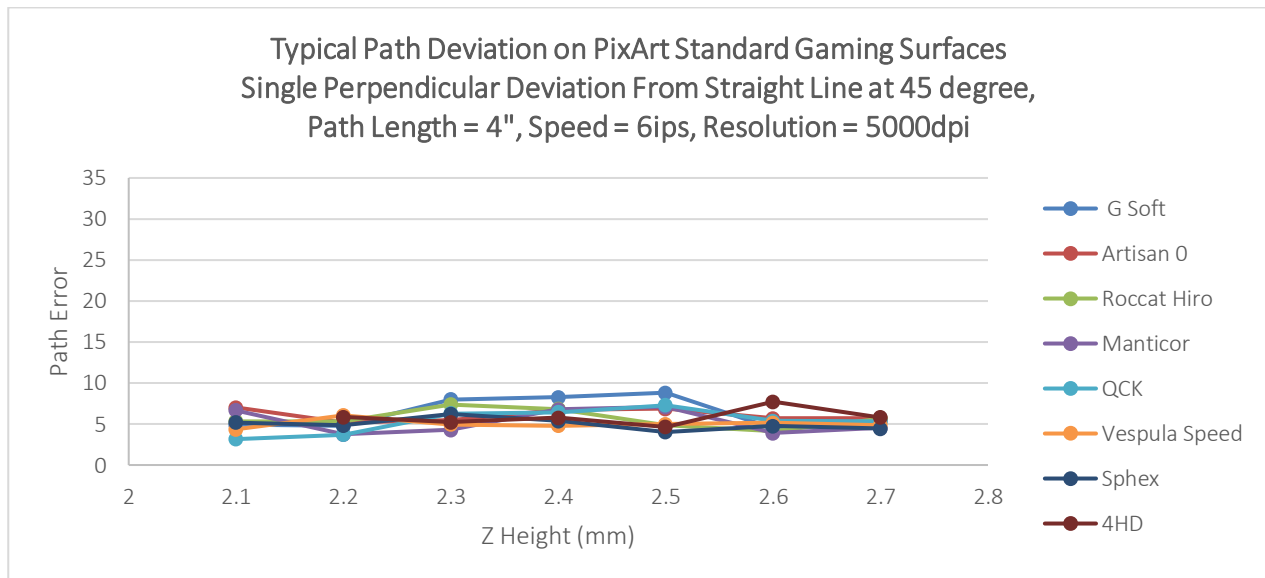

Figure 12. Path Error vs. Z Height at resolution of 5000dpi

5.0 Registers

5.1 Registers Summary Table

PMW3389DM-T3QU registers are accessible via the serial port. The registers are used to read motion data and status as well as to set the device configuration.

Notes: R = Read, W = Write, Read/Write= RW

Address	Register	Access	Default Value	Address	Register	Access	Default Value
0x00	Product_ID	R	0x47	0x24	Observation	RW	0x00
0x01	Revision_ID	R	0x01	0x25	Data_Out_Lower	R	0x00
0x02	Motion	RW	0x20	0x26	Data_Out_Upper	R	0x00
0x03	Delta_X_L	R	0x00	0x2A	SROM_ID	R	0x00
0x04	Delta_X_H	R	0x00	0x2B	Min_SQ_Run	RW	0x10
0x05	Delta_Y_L	R	0x00	0x2C	RawData_Threshold	RW	0x0A
0x06	Delta_Y_H	R	0x00	0x2D	Control2	RW	0x00
0x07	SQUAL	R	0x00	0x2E	Config5_L	RW	0x00
0x08	RawData_Sum	R	0x00	0x2F	Config5_H	RW	0x00
0x09	Maximum_RawData	R	0x00	0x3A	Power_Up_Reset	W	N/A
0x0A	Minimum_RawData	R	0x00	0x3B	Shutdown	W	N/A
0x0B	Shutter_Lower	R	0x12	0x3F	Inverse_Product_ID	R	0xB9
0x0C	Shutter_Upper	R	0x00	0x41	LiftCutoff_Cal3	RW	0x00
0x0D	Ripple Control	RW	0x07	0x42	Angle_Snap	RW	0x00
0x0E	Resolution_L	RW	0x00	0x4A	LiftCutoff_Cal1	RW	0x00
0x0F	Resolution_H	RW	0x42	0x50	Motion_Burst	RW	0x00
0x10	Config2	RW	0x20	0x62	SROM_Load_Burst	W	N/A
0x11	Angle_Tune	RW	0x00	0x63	Lift_Config	RW	0x02
0x12	Frame_Capture	RW	0x00	0x64	RawData_Burst	R	0x00
0x13	SROM_Enable	W	N/A	0x65	LiftCutoff_Cal2	R	0x00
0x14	Run_Downshift	RW	0x32	0x71	LiftCutoff_Cal_Timeout	RW	0x27
0x15	Rest1_Rate_Lower	RW	0x00	0x72	LiftCutoff_Cal_Min_Length	RW	0x09
0x16	Rest1_Rate_Upper	RW	0x00	0x73	PWM_Period_Cnt	RW	0x00
0x17	Rest1_Downshift	RW	0x1F	0x74	PWM_Width_Cnt	RW	0x00
0x18	Rest2_Rate_Lower	RW	0x63				
0x19	Rest2_Rate_Upper	RW	0x00				
0x1A	Rest2_Downshift	RW	0xBC				
0x1B	Rest3_Rate_Lower	RW	0xF3				
0x1C	Rest3_Rate_Upper	RW	0x01				