



Miniature Positioners

Linear Motor and Screw Driven Stages

Miniaturization of fiber optics, photonics, electronics and biomedical processes has driven the need for smaller and more efficient positioners. Parker offers numerous miniature stage solutions.

Miniature Positioning Stages Common Features

- Miniature profile stages as small as 25 X 80 mm
- Travel lengths to 500 mm
- Acceleration to 5 g; velocity to 3 m/sec
- Encoder resolution to 0.01 microns
- Internal cable management or non-moving cables
- Square rail or cross roller bearing systems
- Compatible mounting for multi-axis systems
- Cleanroom prep, low ESD coating and vacuum prep options
- Submicron precision options
- Thorough testing and certification

mSR Miniature Square Rail Positioner

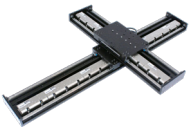

The most accurate standard positioner ever made by Parker. Compact, with an all-encompassing design ideal for a variety of applications.
Page 342.

MX80L Linear Motor Driven Stages

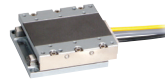

Exceptional straightness and flatness of travel for positioning light loads within a small workspace.
Page 362.

MX80S Ballscrew & Leadscrew Driven Stages



The MX80S offers features like high stiffness, extremely smooth linear translation, and anti-cage creep design. The unique Master Reference Surface allows aligning the process to the actual travel path within microns.
Page 370.

MX80M Free Travel and Micrometer Driven Stages

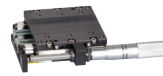

The MX80M is available in free travel or micrometer driven units, with innovative tooling features that make mounting and precision alignment quicker and easier.
Page 377.

MX45S Linear Positioning Stages



Ultra-miniature, high performance positioners for OEMs requiring linear positioning in space restricted applications.
Page 380.

mSR Miniature Square Rail Positioner

Optimize your design and its footprint.

- Two miniature form factors: the mSR 80 measuring 80 x 25 mm, or the mSR 100 measuring 100 x 35 mm.
- Dual precision square rail bearings
- Six different linear encoder options
- Two different linear motor technologies
- Standard travel options ranging from 25 mm to 500 mm of stroke

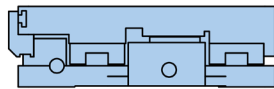
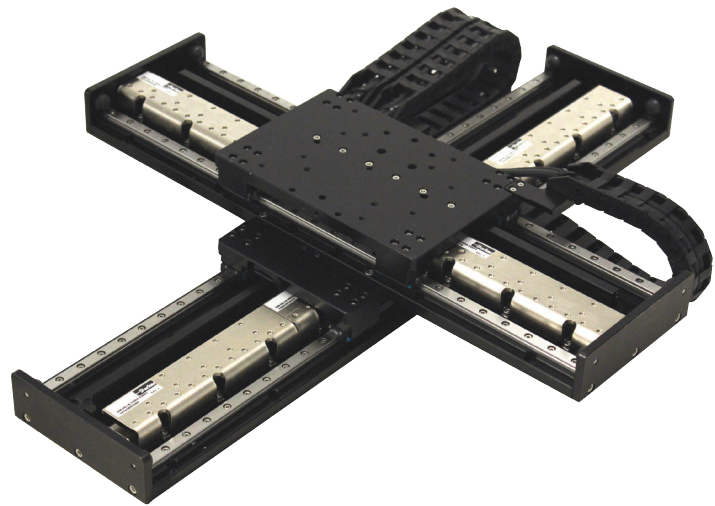

mSR80

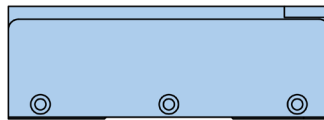

mSR100

HMRS08

Maximum Travel (mm)	1200
Maximum Payload (N)	1800
Maximum Acceleration (m/sec ²)	10

- Integrated and adjustable home and limit sensing
- Common tapped mounting holes and dowel locating holes
- Complete error mapping on each precision grade version – with linear slope correction value provided
- CE and RoHS compliance
- A standard magnetic counterbalance (mSR 80 - 25 mm stroke)

For instrument builders who need smooth motion in a small package, the mSR is a linear positioner that provides sub-micron level precision in two different form factors (80 and 100).

The mSR series is a precision machined, square rail bearing guided linear positioner which is driven with one of two different linear servo motor technologies, and utilizes selectable levels of linear encoder technology that are configured to match the application need.

The mSR was developed to complement the successful MX80L positioner, and allows OEM's developing equipment a number

of added layers of value, in an extremely compact package, which is easy to apply, and can be tailor-fitted to match the need regardless if one is interested in the reliability of a cost-competitive mechanically driven alternative, or a high precision positioner delivering best of breed performance – all in the same footprint.

Because of its compact, all-encompassing design, the mSR is an ideal positioning solution for applications in the life sciences. Typical applications range from imaging systems performing scanning operations to identify biological markers, to high-throughput processing of micro

plates, to applications in cellular therapeutics requiring cell selection and high precision placement to supplement regenerative medicine techniques. Know that the mSR has been designed with typical instrument regulations and certifications in mind as all versions meet CE and RoHS requirements.

Likewise, the mSR is also ideal in application in electronics manufacturing due to its low profile and precision performance. Typical applications could range from semiconductor metrology, to wafer scribing.



The Best of Both Worlds

The mSR design has been optimized around two different linear motor technologies to best suit packaging restraints and application needs. Each of these motors has been optimized to deliver best in class performance and response.

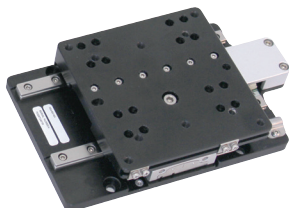

mSR80 Ironcore

Ironcore Technology Benefits

- High force per size
- Lower cost
- Excellent heat dissipation

The mSR80 uses the same ironcore linear motor technology used on the MX80L, but it allows for a wider variety of encoder technologies to be applied in a similar foot print, delivering higher performance at a lower relative cost. The mSR80 has been designed to minimize the overall packaging while still achieving MX80L level thrust.

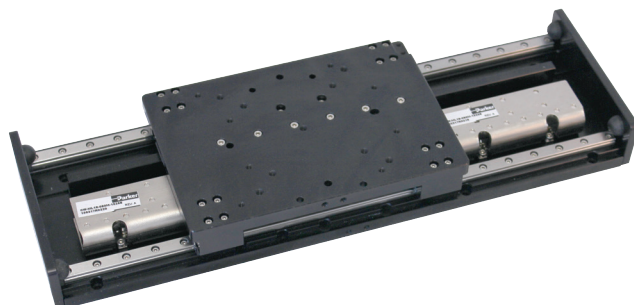
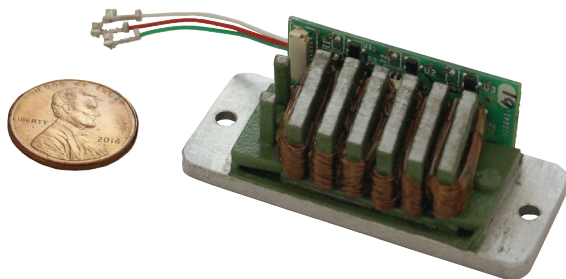

mSR100 Ironless

Ironless Technology Benefits

- No attractive forces between stator and magnet track – yielding smoother phase transitions
- No cogging
- Lower force weight

The mSR100 makes use of Parker's latest ironless linear motor, the ML18. As a result the mSR100 is ideal for applications requiring a higher load than the mSR 80, extremely smooth motion, or minimal velocity ripple. The mSR100 also allows for strokes up to 500 mm, as well as a BiSS-C absolute encoder for applications requiring constant positional information.

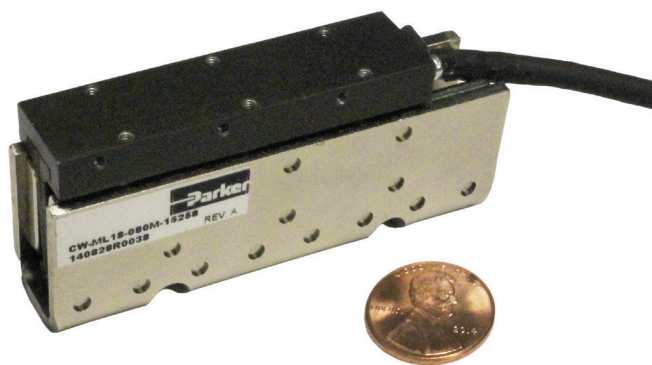

Within the same form factor, OEMs have two options:

- The precision grade mSR is the most accurate **standard** positioner ever made by Parker, achieving a repeatability of 100 nm and an accuracy of 5.0 microns over 50 millimeters of stroke.
- The more cost competitive standard version takes advantage of magnetic encoder technology, which is ideal for applications which do not require the same level of precision, to compete with similar ballscrew driven stages.

These positioners are ideal for a variety of applications, ranging from imaging systems in digital pathology equipment to metrology instruments in semiconductor or electronics manufacturing.

Maximize Instrument Performance — Not Its Size

The mSR (miniature square rail) positioner offers instrument builders optimized packaging of a linear motor, guidance and encoder, as well as limits and home sensors in one complete solution.

Best of Breed Encoder Technology

The mSR positioner offers instrument builders a plethora of different encoding technologies and resolutions to select from.

Standard incremental optical resolutions range from one micron all the way down to ten nanometers of resolution. This optical encoder offers exceptionally low sub-divisional errors, allowing for very tight control over velocity ripple.

The analog (sine/cosine) encoder option is an ideal way to reach high resolution when paired with controls using interpolating technology to achieve high precision and high speed.

A one micron magnetic option is ideal for cost sensitive applications requiring more basic positioning, and lastly, the mSR 100 offers a BiSS-C encoder option to give absolute feedback for applications requiring constant positional information.

mSR Series Specifications

	Units	mSR80	mSR100
Size (W x H)	mm	80 x 25	100 x 35
Travel (Max)	mm	150	500
Normal Load (Max)	kg	8	12
Thrust (Max)			
Continuous	N	8	16.7
Peak		24	50
Acceleration (Max – no load)	G	3	3
Speed (Max – no load) ¹	mm/s	2000	3000
Rated Bus Voltage	Volts DC	48	48
Repeatability ²	µm	±0.1	±0.2
Accuracy ^{2,3}	µm	5	5
Straightness & Flatness ²	µm	±4	±4
Feedback Compatibility			
1 µm Optical (incremental)		•	•
0.1 µm Optical (incremental)		•	•
0.01 µm Optical (incremental)		•	•
Analog Sine/Cosine		•	•
1 µm Magnetic (incremental)		•	•
0.05 µm BiSS-C (absolute)			•

¹ At 48 Volt DC bus

² Precision grade version stage mounted to granite surface, 0.01 micron optical encoder, 50 mm stroke

³ Measurements taken at 35 mm above the center of the carriage, with linear slope correction

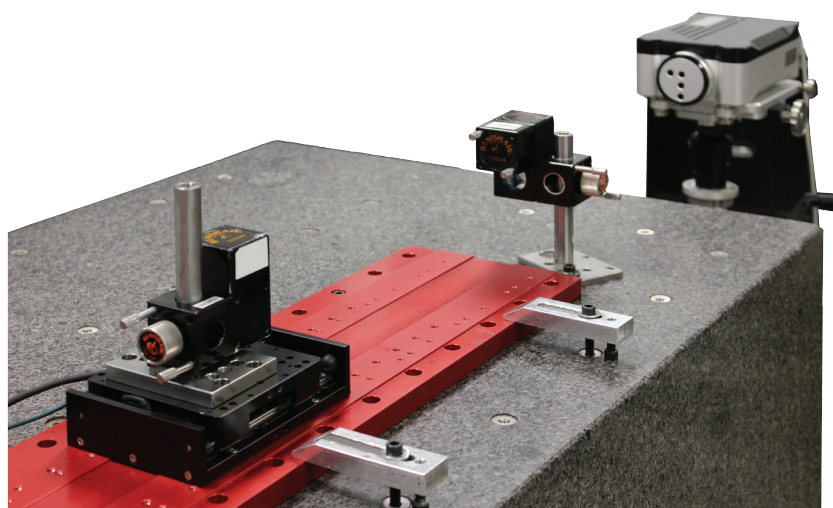

Laser Grade Precision

Every precision grade mSR is thoroughly tested with Parker's laser interferometer to ensure that it meets product specification. Parker also provides test data, with a linear slope corrected value noted, yielding higher stage accuracy with controller compensation.

mSR Application Solutions

Electronics Manufacturing

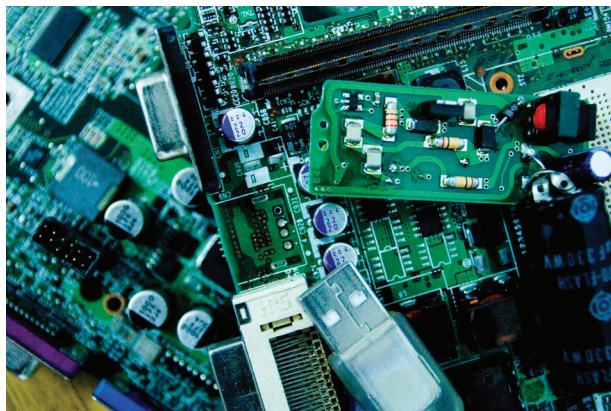

The mSR is an ideal positioning system for high throughput electronics manufacturing equipment, as its design combines high performance linear motor technology with a variety of high resolution feedback devices for quick, precise placement of miniature components. The mSR also provides an extremely robust solution for electronics inspection systems, as its direct drive linear motor technology has been designed to stand the test of time.

Life Sciences - Digital Pathology

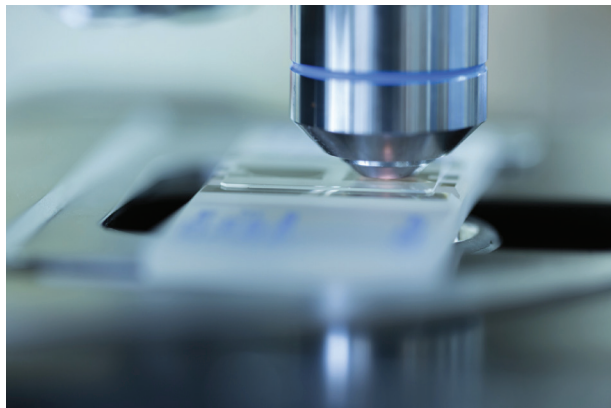

Miniature packaging, high precision performance, and quick settling times make the mSR an optimum solution for imaging instruments used in digital pathology. With limited wear components the mSR is a durable stage that will minimize the risk of machine downtime.

Life Sciences - Cellular Therapeutics



With the emergence of cellular therapeutics, the mSR provides a high precision, miniature means of picking and placing cells for cell therapy instruments. These instruments require highly repeatable positioning to pick cells of interest and incubate them for future cell based therapies.

Semiconductor Handling and Metrology

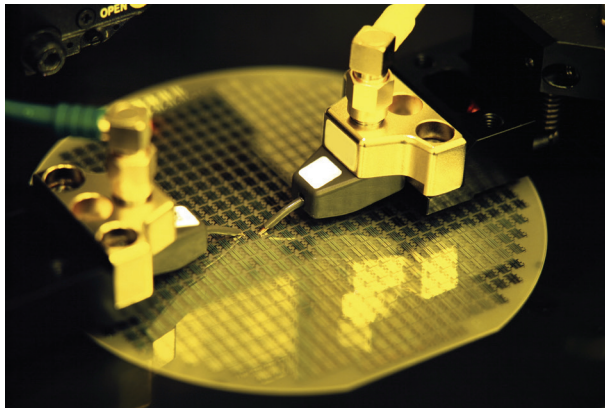

Given the combination of its superior geometric performance and miniature packaging, the mSR series positioner is ideal for semiconductor handling and metrology applications. Regardless of whether you are examining features on the micro or nano-scale, the mSR can be adapted to meet the need with its wide array of encoder options. The mSR also offers a stroke scalable mechanical solution with standard designs up to 500 mm.

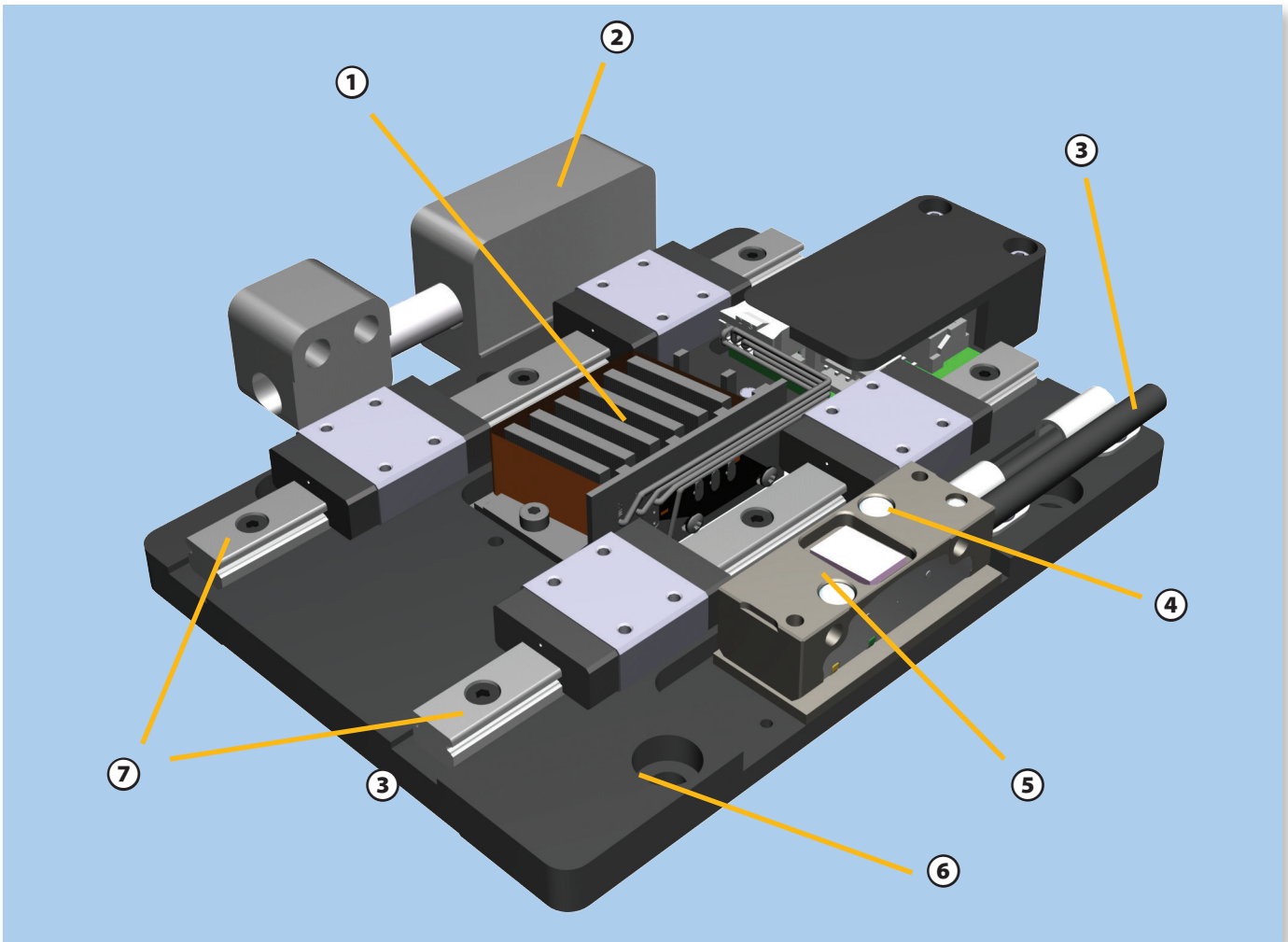

1 Center Driven Ironcore Linear Motor
The mSR80 offers both a 4 and 8 pole ironcore linear motor based upon the application thrust requirements. Each of these motors have been optimized to operate on 48 Volts DC.

2 An Optional Magnetic Counterbalance
The mSR80 with 25 mm stroke has an optional magnetic counterbalance that can be used for Z axis applications. The magnetic counter balance is a more robust solution when compared to spring or pneumatic driven alternatives.

3 High Flex Cabling
The mSR uses high flex cabling as standard to ensure maximum life of the stage regardless of whether it's integrated into a multi or single axis system.

4 Integrated and Adjustable Home and Limit Sensing
Home and limit sensors have been integrated into the mSR80 encoder read head, and signals are passed through the same cable, minimizing the amount of cables requiring cable management

5 Five Different Linear Encoder Technologies
The mSR80 provides maximum versatility with three different optical encoder resolutions (1, 0.1, and 0.01 micron), an analog sine/cosine option as well as an economical 1 micron magnetic option.

6 Tapped Holes and Dowel Pinning
The mSR has tapped holes in both the top and base for ease of mounting and dowel pins to ensure repeatable mounting when configuring XY systems made with mSR positioners.

7 Dual Precision Square Rails
Two precision aligned square rail bearings support the payload and provide superior straightness and flatness.

CE and RoHS Compliance
The mSR conforms to both CE and RoHS directives as standard.



SPECIFICATIONS

The mSR series of miniature, dual square rail guided, linear motor positioners have been engineered to deliver a combination of modularity, flexibility, and performance in an extremely compact package.



		Travel (mm)				
Specification	Units	25	35	50	100	150
Max. Load	kg (lb)	4 (9)	4 (9)	8 (18)	8 (18)	8 (18)
Peak Thrust	N (lb)	12 (2.7)	12 (2.7)	24 (5.4)	24 (5.4)	24 (5.4)
Continuous Thrust	N (lb)	4 (0.9)	4 (0.9)	8 (1.8)	8 (1.8)	8 (1.8)
Duty Cycle (Acceleration and Load Dependent)	%	100				
Acceleration (Unloaded)	G	3				
Straightness & Flatness	Standard Grade	±6	±6	±8	±10	±15
	Precision Grade	±3	±3	±4	±5	±10
Carriage Mass	kg	0.2365	0.2365	0.3065	0.4115	0.519
Stage Mass	kg	0.525	0.5815	0.7395	1.0665	1.403

Magnetic Encoder – 1 Micron Resolution

Max. Speed	mm/s	1100	1500	2000	2000	2000
Bi-Directional Repeatability	µm	±5.0				
Positional Accuracy	µm	40	40	60	80	80

Optical Encoder – 1 Micron Resolution

Max. Speed	mm/s	1100	1500	2000	2000	2000
Bi-Directional Repeatability	µm	±2.0				
Positional Accuracy	µm	9	9	9	11	13
Positional Accuracy (Slope Corrected)	µm	5	6	6	6	7

Optical Encoder – 0.1 Micron Resolution

Max. Speed	mm/s	300	300	300	300	300
Bi-Directional Repeatability	µm	±0.3				
Positional Accuracy	µm	8	8	8	10	12
Positional Accuracy (Slope Corrected)	µm	4	5	5	5	6

Optical Encoder – 0.01 Micron Resolution

Max. Speed	mm/s	30	30	30	30	30
Bi-Directional Repeatability	µm	±0.1				
Positional Accuracy	µm	8	8	8	10	12
Positional Accuracy (Slope Corrected)	µm	4	5	5	5	6

Miniature Positioners

mSR80 Force/Speed Performance

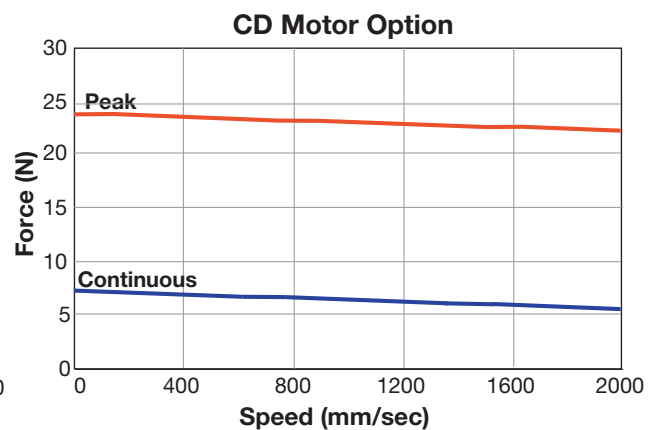
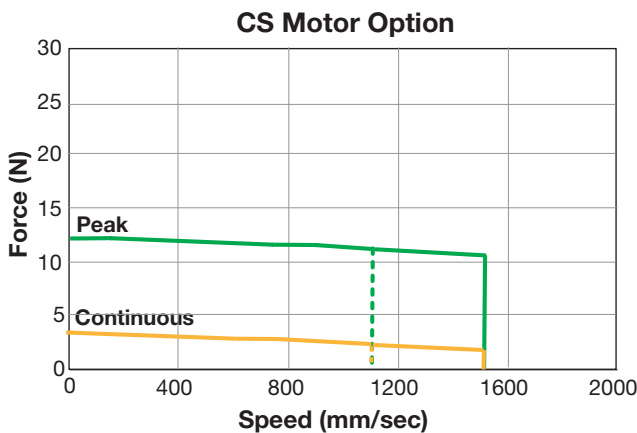

DIMENSIONS

DIMENSIONS

Dimensions – mm (in)

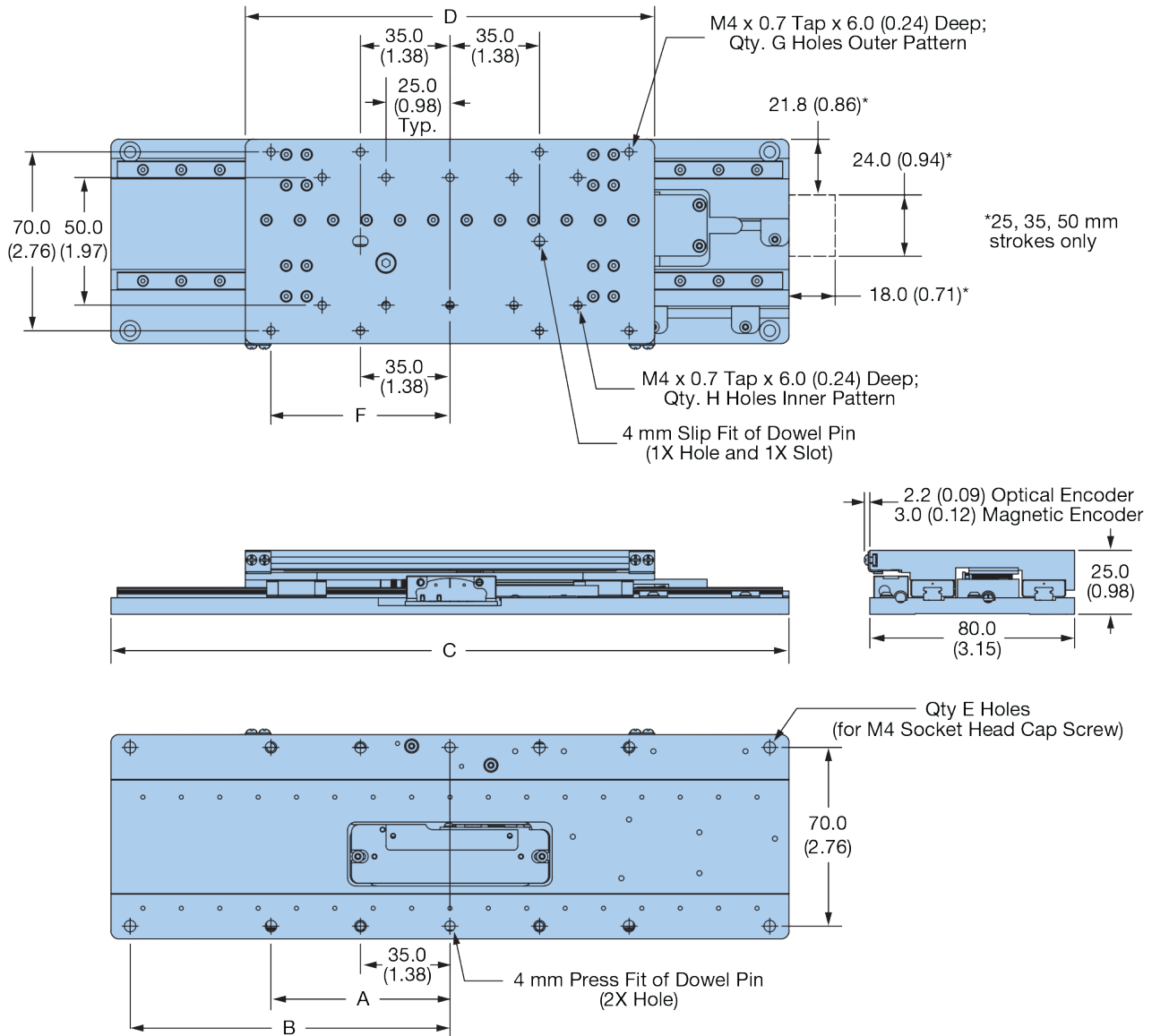

Dimensions – mm (in)

Travel (mm)	A	B	C	D	Qty. E	F	Qty. G	Qty. H
25	—	—	110 (4.33)	80	4	—	4	6
35	—	—	120 (4.72)	80	4	—	4	6
50	70 (2.76)	—	165 (6.50)	110 (4.33)	8	—	4	6
100	70 (2.76)	125 (4.92)	265 (10.43)	160 (6.30)	12	70 (2.76)	8	10
150	100 (3.94)	175 (6.89)	365 (14.37)	210 (8.27)	12	100 (3.94)	8	14

Free sizing and selection support
from Virtual Engineer at
parker.com/VirtualEngineer



mSR Motor Information

Motor Specifications	Units	mSR80		mSR100	
		4 Pole (CS Option)	8 Pole (CD Option)	3 Pole (LS Option)	5 Pole (LD Option)
Magnetic Pitch	mm	13	13	40	40
Continuous Force ¹	N	4	8	11	16.7
Peak Force	N	12	24	33	50
Continuous Current ¹	A (rms)	0.8	1.6	1.2	2.18
Peak Current ^{2,3}	A (rms)	2.4	4.8	3.5	6.5
Voltage Constant ^{2,3}	Volts/m/s	4.5	4.5	7.7	6.3
Force Constant ²	N/A (rms)	5.51	5.51	9.4	7.65
Resistance ²	Ohms	8.8	4.3	6.3	2.82
Inductance ⁴	mH	2.4	1.6	1	0.5
Max Bus Voltage	VDC	48	48	48	48
Rated/Max Winding Temperature	Degrees C	25/95	25/95	25/125	25/125
Thermal Resistance _(winding to case)	C/Watt	3.68	1.32	1.6	0.92
Thermal Resistance _(case to ambient)	C/Watt	3.16	2.08	3.9	2.64
Winding Thermal Time Constant	Minutes	0.5	0.5	1.3	0.8
Motor Thermal Time Constant	Minutes	0.8	0.8	15	10

¹ @ 25° C ambient

² Measured line to line

³ Value is measured peak of sine

⁴ ±30% Line-to-Line, induction bridge measurement @ 1 KHz

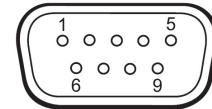
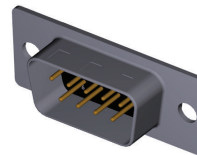

Miniature Positioners

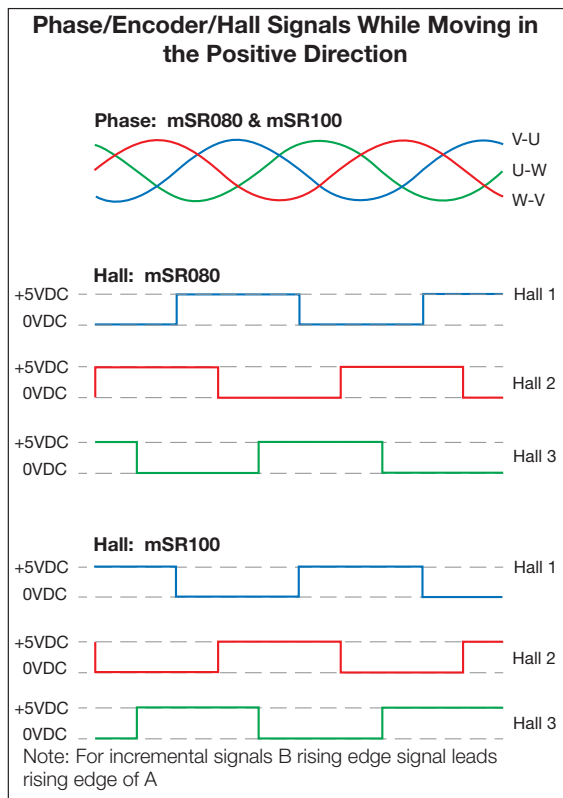

Motor and Hall Wiring

Function	Color	Pin #
Motor Phase U	Red	1
Motor Phase V	Brown	2
Motor Phase W	Orange	3
PE Ground	Green/Yellow	4
Hall Power (+5 Volts DC)	Black	5
Hall Ground	White	6
Hall 1	Yellow	7
Hall 2	Blue	8
Hall 3	Green	9

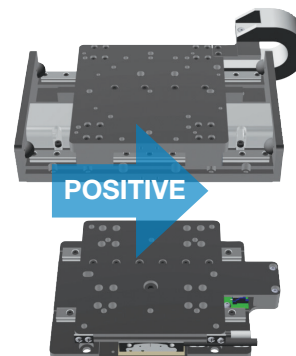

Optical Encoder

Function	Signal	Pin #
Power	5 Volts DC	8
	Ground	2, 9
Incremental Signals	A+	14
	A-	6
	B+	13
	B-	5
Reference Mark	Z+	12
	Z-	4
Limits	Positive Limit	11
	Negative Limit	10
Setup	(Used in installation)	1
Error Output	NPN	3

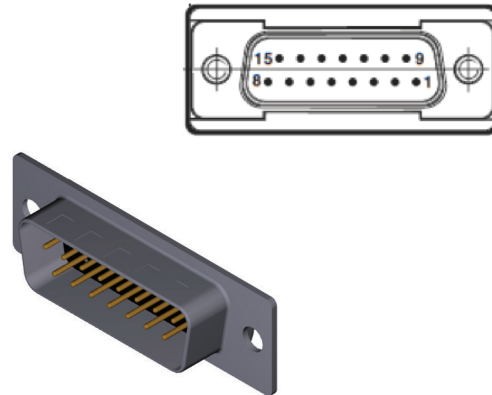

Sine Cosine Encoder

Function	Signal	Pin #
Power	5 Volts DC	4, 5
	0 Volts DC	12, 13
Incremental Signals	Cosine +	9
	Cosine -	1
	Sine +	10
	Sine -	2
Reference Mark	Z+	3
	Z-	11
Limits	Positive Limit	7
	Negative Limit	8
Setup	(Used in installation)	6
Remote Calibration	NPN	14

Magnetic Encoder

Function	Signal	Pin #
Power	5 Volts DC	8
	Ground	9
Incremental Signals	A +	14
	A -	6
	B +	13
	B -	5
Reference Mark	Z+	12
	Z-	4
Limits	Positive Limit	11
	Negative Limit	10
Home	NPN	2
Error Output	NPN	3

BiSS-C Absolute Encoder (mSR100 only)

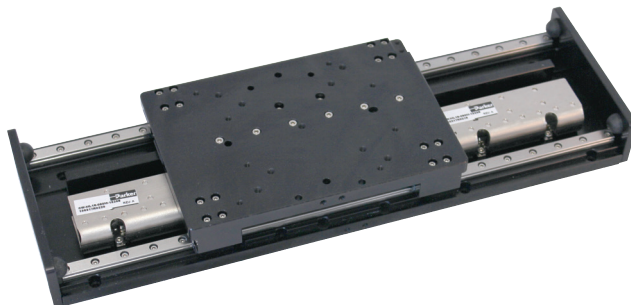

Function	Signal	Color
Power	5 Volts DC	Brown
	Ground	Green White
Serial Communications	MA+	Violet
	MA-	Yellow
	SLO+	Grey
	SLO-	Pink
Shield	Inner shield	-
	Outer	Case

Drive/Control Solutions



The Intelligent Parker Amplifier or IPA, is a versatile servo drive/controller based on the ACR control platform.

The IPA provides a dual port Ethernet interface which gives the machine builder the flexibility needed to create cost effective motion control solutions.

The IPA operates as a fully programmable stand-alone motion controller with on-board I/O and virtual axis capability or can be integrated into a PLC or PC-based machine control solution.

Software tools are included to optimize motion performance and efficiently monitor and manage the application.

EtherNet/IP gives IPA users a popular connectivity option to PLCs for easy integration of servo motion in larger machine control application. The IPA is an EtherNet/IP adapter device supporting both I/O and Explicit Messaging. Add-On Instructions are available for seamless integration with Logix controllers.

Drive Solutions



The P-Series drives operate with a variety of machine control architectures and offer sophisticated servo functionality. Accurate and easy to use inertia detection leads to fast set-up of tuning parameters and minimal settling time.

Advanced filtering and vibration suppression features can be used to increase throughput and improve positioning performance.

For high speed, real-time network applications, the P-Series is available with EtherCAT, the fastest growing, most flexible industrial Ethernet protocol. Ideal for use with the Parker Automation Controller, the P-Series also follows the open standards for EtherCAT.

The Pulse version can be configured for step and direction control input and includes analog inputs for torque or velocity control. Select Indexer mode to create up to 64 position table entries triggered via inputs or over an RS422 interface.

Parker Drives and Cable Accessory Part Numbers

Encoder Type	Drive	Cable Interconnect Part Number
Digital	IPA	006-2690-01
Analog	IPA	006-2692-01
Digital	P Series	006-2691-01
Digital/Analog	Motor Power and Hall Flying Lead	006-2678-01
Digital	Digital Encoder Flying Lead	006-2679-01
Analog	Analog Encoder Flying Lead	006-2680-01

Multi-axis Systems

The mSR series was designed to be highly modular, such that it can easily be configured into multi-axis systems made out of other mSR or MX80L positioners, as the mSR80 uses the same bolt pattern. Since the entire mSR series was designed with this common hole pattern in mind, X-Y systems can be developed without the need for an additional transition plate.



Example mSR80 X-Y system

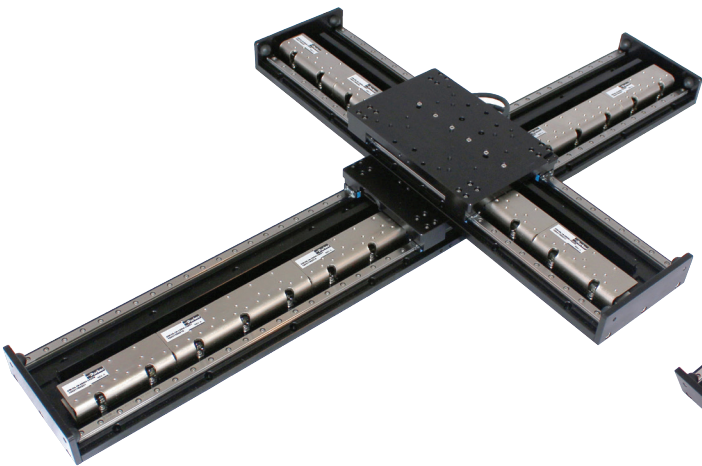

mSR100 X-Y standard orientation



mSR100 X-Y carriage-to-carriage direct mount orientation

The mSR100 was designed such that it can be configured into two different X-Y orientations: one reflecting a standard X-Y design and the other with the carriages mounted directly to one another. If you choose to develop your machine with the carriage-to-carriage approach, the Y axis cable carrier is eliminated.

The mSR100 is also populated with mounting holes to mount an mSR80 directly to it so that X-Y, X-Z or X-Y-Z systems can be created with any combination of the mSR80 and mSR100. Pictured here is the mSR80 with a standard Z bracket.

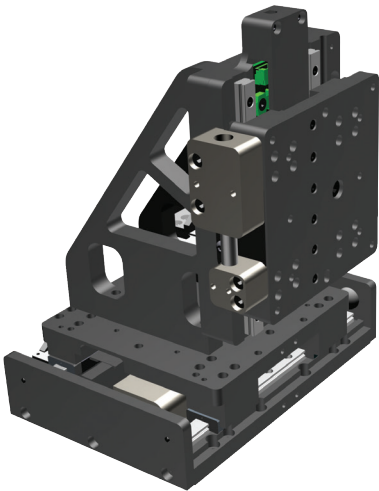

mSR100 X with mSR80 Z including magnetic counterbalance

Z-Axis Brackets

mSR80 & mSR100	Part Number
25, 35, and 50 mm	002-2238-01
100 & 150 mm	002-2240-01

Miniature Positioners

ORDERING INFORMATION

mSR80

Fill in an order code from each of the numbered fields to create a complete part number

Order Example:

①	②	③	④	⑤	⑥	⑦	⑧	⑨	⑩	⑪	⑫
MSR	080	L	050	P	CD	E3	H1	L1	CM01	X0	

- ① **Series**
MSR Series
- ② **Size (width in mm)**
080 80 mm wide profile
- ③ **Drive Train**
L Linear Motor Drive
- ④ **Stroke Length (mm)**
025 25 mm
035 35 mm
050 50 mm
100 100 mm
150 150 mm
- ⑤ **Grade**
P Precision
S Standard
- ⑥ **Motor**
CS Ironcore, single (25 and 35 mm travels only)
CD Ironcore, double (50, 100, and 150 mm travels only)
- ⑦ **Encoder**
E1 1µm optical incremental*
E2 0.1µm optical incremental*
E3 0.01µm optical incremental*
SC Sine/Cosine*
M1 1µm magnetic incremental**
*Available on precision grade only
**Available on standard grade only
- ⑧ **Home Sensor**
H1 Home Sensor (M1 Option), Index Mark (E1, E2, E3, and SC Options)
- ⑨ **Limit Sensor**
L1 End-of-travel limit sensors
- ⑩ **Cable Options**
CM01 No cable management, 1 meter
CM03 No cable management, 3 meter
- ⑪ **Other Options**
X0 No counter balance
X1 Magnetic counterbalance* (0.5 N)
X2 Magnetic counterbalance* (2.0 N)
X3 Magnetic counterbalance* (3.0 N)
X4 Magnetic counterbalance* (3.5 N)
X5 Magnetic counterbalance* (4.3 N)
X6 Magnetic counterbalance* (6.3 N)
*Available on 25 mm stroke only

Free sizing and selection support
from Virtual Engineer at
parker.com/VirtualEngineer



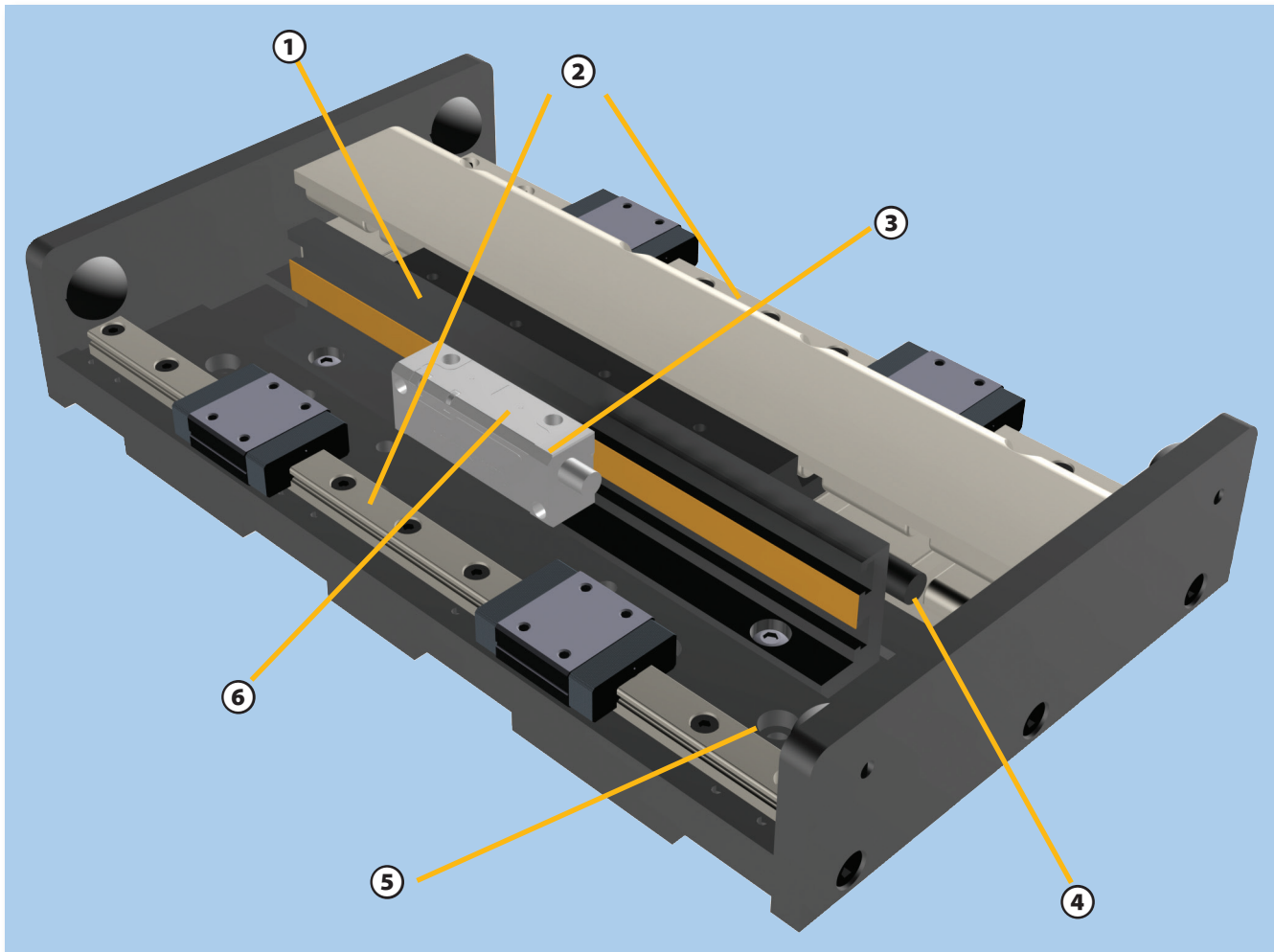

- 1 Center Driven Ironless Linear Motor**
The mSR100 offers both a 3 and 5 pole ironless linear motor (mL18) — space based upon the application thrust requirements. Each of these motors have been optimized to operate on 48 Volts DC.
- 2 Dual Precision Square Rails**
Two precision aligned square rail bearings to support the payload and provide superior straightness and flatness.
- 3 Integrated Home and Limit Sensing**
Home and limit sensors have been integrated into the mSR100 encoder read head, and signals are passed through the same cable, minimizing the amount of cables requiring cable management.
- 4 High Flex Cabling**
The mSR uses high flex cabling as standard to ensure maximum life of the stage regardless of whether it's integrated into a multi or single axis system.

- 5 Tapped Holes and Dowel Pinning**
The mSR has tapped holes in both the top and base for ease of mounting, and dowel pins to ensure repeatable mounting when configuring XY systems made with mSRs.

- 6 Six Different Linear Encoder Technologies**
The mSR100 provides maximum versatility with three different optical encoder resolutions (1, 0.1, and 0.01 micron), an analog sine/cosine option as well as an economical 1 micron magnetic option. The mSR100 also offers a BiSS-C, 0.05 micron absolute encoder option for application that require constant positional feedback.

CE and RoHS Compliance

The mSR conforms to both CE and RoHS directives as standard.



SPECIFICATIONS

The mSR series of miniature, dual square rail guided, linear motor positioners have been engineered to deliver a combination of modularity, flexibility, and performance in an extremely compact package.

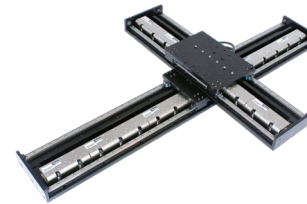

Specification	Units	Travel (mm)											
		25 (LS)	50 (LS)	50 (LD)	100 (LS)	100 (LD)	150 (LS)	150 (LD)	200 (LS)	200 (LD)	250 (LS)	250 (LD)	
Maximum Load	kg (lb)	12 (26.5)	12 (26.5)	12 (26.5)	12 (26.5)	12 (26.5)	12 (26.5)	12 (26.5)	12 (26.5)	12 (26.5)	12 (26.5)	12 (26.5)	
Peak Thrust	N (lb)	33 (7.4)	33 (7.4)	50 (11.2)	33 (7.4)	50 (11.2)	33 (7.4)	50 (11.2)	33 (7.4)	50 (11.2)	33 (7.4)	50 (11.2)	
Continuous Thrust	N (lb)	11 (2.5)	11 (2.5)	16.7 (3.75)	11 (2.5)	16.7 (3.75)	11 (2.5)	16.7 (3.75)	11 (2.5)	16.7 (3.75)	11 (2.5)	16.7 (3.75)	
Duty Cycle (Acceleration & Load Dependent)	%	100											
Acceleration (Unloaded)	G	3											
Straightness & Flatness	Standard Grade	±5	±5	±5	±8	±8	±8	±8	±8	±8	±10	±10	
	Precision Grade	±3	±3	±3	±4	±4	±4	±4	±4	±4	±5	±5	
Carriage Mass	kg	0.34	0.34	0.46	0.34	0.46	0.34	0.46	0.34	0.46	0.34	0.46	
Stage Mass	kg	1.06	1.21	1.57	1.45	1.80	1.68	2.03	1.91	2.35	2.23	2.59	

Specification	Units	Travel (mm)									
		300 (LS)	300 (LD)	350 (LS)	350 (LD)	400 (LS)	400 (LD)	450 (LS)	450 (LD)	500 (LS)	500 (LD)
Maximum Load	kg (lb)	12 (26.5)	12 (26.5)	12 (26.5)	12 (26.5)	12 (26.5)	12 (26.5)	12 (26.5)	12 (26.5)	12 (26.5)	12 (26.5)
Peak Thrust	N (lb)	33 (7.4)	50 (11.2)	33 (7.4)	50 (11.2)	33 (7.4)	50 (11.2)	33 (7.4)	50 (11.2)	33 (7.4)	50 (11.2)
Continuous Thrust	N (lb)	11 (2.5)	16.7 (3.75)	11 (2.5)	16.7 (3.75)	11 (2.5)	16.7 (3.75)	11 (2.5)	16.7 (3.75)	11 (2.5)	16.7 (3.75)
Duty Cycle (Acceleration & Load Dependent)	%	100									
Acceleration (Unloaded)	G	3									
Straightness & Flatness	Standard Grade	±10	±10	±12	±12	±16	±16	±20	±20	±20	±20
	Precision Grade	±5	±5	±6	±6	±8	±8	±10	±10	±12	±12
Carriage Mass	kg	0.34	0.46	0.34	0.46	0.34	0.46	0.34	0.46	0.34	0.46
Stage Mass	kg	2.47	2.82	2.7	3.05	2.93	3.37	3.25	3.6	3.48	3.84

mSR100 Force/Speed Performance

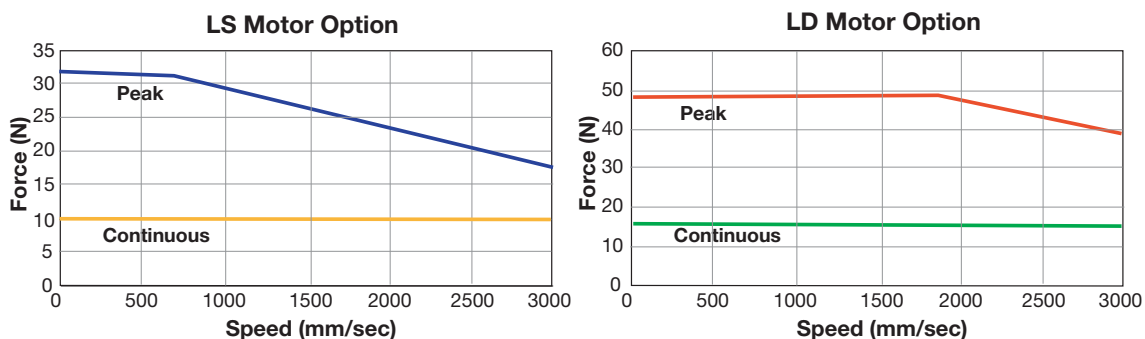

mSR100 Specifications (Travel & Encoder Dependent)

Specification	Units	Travel (mm)										
		25 (LS)	50 (LS)	50 (LD)	100 (LS)	100 (LD)	150 (LS)	150 (LD)	200 (LS)	200 (LD)	250 (LS)	250 (LD)
Magnetic Encoder – 1 Micron Resolution												
Max. Speed	mm/s	1100	1500	3000	3000	3000	3000	3000	3000	3000	3000	3000
Bi-directional Repeatability	μm	±5.0										
Positional Accuracy	μm	40	40	40	80	80	80	80	100	100	100	100
Optical Encoder – 1 Micron Resolution												
Max. Speed	mm/s	1100	1500	3000	3000	3000	3000	3000	3000	3000	3000	3000
Bi-directional Repeatability	μm	±2.0										
Positional Accuracy	μm	10	10	10	10	10	10	10	12	14	14	14
Positional Accuracy (Slope Corrected)	μm	6	6	6	6	6	7	7	7	7	8	8
Optical Encoder – 0.1 Micron Resolution												
Max. Speed	mm/s	300	300	300	300	300	300	300	300	300	300	300
Bi-directional Repeatability	μm	±0.4										
Positional Accuracy	μm	9	9	9	9	9	9	9	11	11	13	13
Positional Accuracy (Slope Corrected)	μm	5	5	5	5	5	6	6	6	6	7	7
Optical Encoder – 0.01 Micron Resolution												
Max. Speed	mm/s	30	30	30	30	30	30	30	30	30	30	30
Bi-directional Repeatability	μm	±0.2										
Positional Accuracy	μm	8	8	8	8	8	8	8	10	10	12	12
Positional Accuracy (Slope Corrected)	μm	4	4	4	4	4	5	5	5	5	6	6
BiSS-C Absolute Encoder – 0.05 Micron Resolution												
Max. Speed	mm/s	1100	1500	3000	3000	3000	3000	3000	3000	3000	3000	3000
Bi-directional Repeatability	μm	±0.4										
Positional Accuracy	μm	9	9	9	9	9	9	9	11	11	13	13
Positional Accuracy (Slope Corrected)	μm	5	5	5	5	5	6	6	6	6	7	7

mSR100 Specifications (Travel & Encoder Dependent)

Specification	Units	Travel (mm)									
		300 (LS)	300 (LD)	350 (LS)	350 (LD)	400 (LS)	400 (LD)	450 (LS)	450 (LD)	500 (LS)	500 (LD)
Magnetic Encoder – 1 Micron Resolution											
Max. Speed	mm/s	3000	3000	3000	3000	3000	3000	3000	3000	3000	3000
Bi-directional Repeatability	μm	±5.0									
Positional Accuracy	μm	100	100	100	100	100	100	100	100	100	100
Optical Encoder – 1 Micron Resolution											
Max. Speed	mm/s	3000	3000	3000	3000	3000	3000	3000	3000	3000	3000
Bi-directional Repeatability	μm	±2.0									
Positional Accuracy	μm	16	16	18	18	20	20	22	22	24	24
Positional Accuracy (Slope Corrected)	μm	8	8	9	9	9	9	10	10	10	10
Optical Encoder – 0.1 Micron Resolution											
Max. Speed	mm/s	300	300	300	300	300	300	300	300	300	300
Bi-directional Repeatability	μm	±0.4									
Positional Accuracy	μm	15	15	17	17	19	19	21	21	23	23
Positional Accuracy (Slope Corrected)	μm	7	7	8	8	8	8	9	9	9	9
Optical Encoder – 0.01 Micron Resolution											
Max. Speed	mm/s	30	30	30	30	30	30	30	30	30	30
Bi-directional Repeatability	μm	±0.2									
Positional Accuracy	μm	14	14	16	16	18	18	20	20	22	22
Positional Accuracy (Slope Corrected)	μm	6	6	7	7	7	7	8	8	8	8
BiSS-C Absolute Encoder – 0.05 Micron Resolution											
Max. Speed	mm/s	3000	3000	3000	3000	3000	3000	3000	3000	3000	3000
Bi-directional Repeatability	μm	±0.4									
Positional Accuracy	μm	15	15	17	17	19	19	21	21	23	23
Positional Accuracy (Slope Corrected)	μm	7	7	8	8	8	8	9	9	9	9

DIMENSIONS

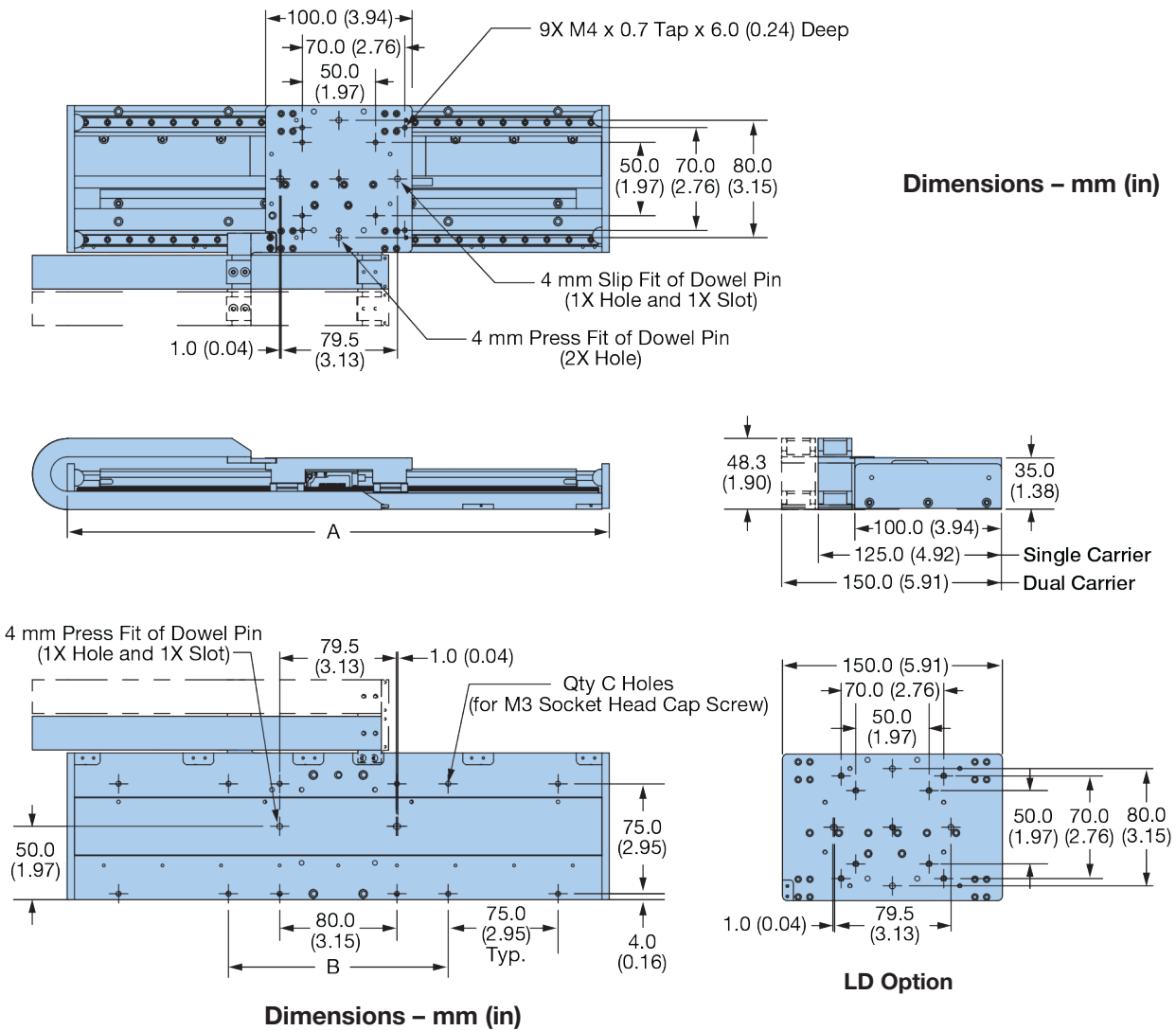

Miniature Positioners

Travel (mm)		A	B	Qty. C
LS Option	LD Option			
25	—	145 (5.71)	100 (3.94)	8
50	—	170 (6.69)	125 (4.92)	8
100	50	220 (8.66)	150 (5.91)	8
150	100	270 (10.63)	200 (7.87)	8
200	150	320 (12.60)	125 (4.92)	8
250	200	370 (14.57)	150 (5.91)	12
300	250	420 (16.54)	200 (7.87)	12
350	300	470 (18.50)	125 (4.92)	12
400	350	520 (20.47)	150 (5.91)	12
450	400	570 (22.44)	200 (7.87)	16
500	450	620 (24.41)	125 (4.92)	16
—	500	670 (26.38)	150 (5.91)	16

mSR Motor Information

Motor Specifications	Units	mSR80		mSR100	
		4 Pole (CS Option)	8 Pole (CD Option)	3 Pole (LS Option)	5 Pole (LD Option)
Magnetic Pitch	mm	13	13	40	40
Continuous Force ¹	N	4	8	11	16.7
Peak Force	N	12	24	33	50
Continuous Current ¹	A (rms)	0.8	1.6	1.2	2.18
Peak Current ^{2,3}	A (rms)	2.4	4.8	3.5	6.5
Voltage Constant ^{2,3}	Volts/m/s	4.5	4.5	7.7	6.3
Force Constant ²	N/A (rms)	5.51	5.51	9.4	7.65
Resistance ²	Ohms	8.8	4.3	6.3	2.82
Inductance ⁴	mH	2.4	1.6	1	0.5
Max Bus Voltage	VDC	48	48	48	48
Rated/Max Winding Temperature	Degrees C	25/95	25/95	25/125	25/125
Thermal Resistance _(winding to case)	C/Watt	3.68	1.32	1.6	0.92
Thermal Resistance _(case to ambient)	C/Watt	3.16	2.08	3.9	2.64
Winding Thermal Time Constant	Minutes	0.5	0.5	1.3	0.8
Motor Thermal Time Constant	Minutes	0.8	0.8	15	10

¹ @ 25° C ambient

² Measured line to line

³ Value is measured peak of sine

⁴ ±30% Line-to-Line, induction bridge measurement @ 1 KHz

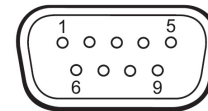
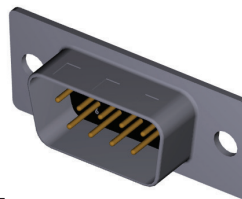

Phase/Encoder/Hall Signals While Moving in the Positive Direction

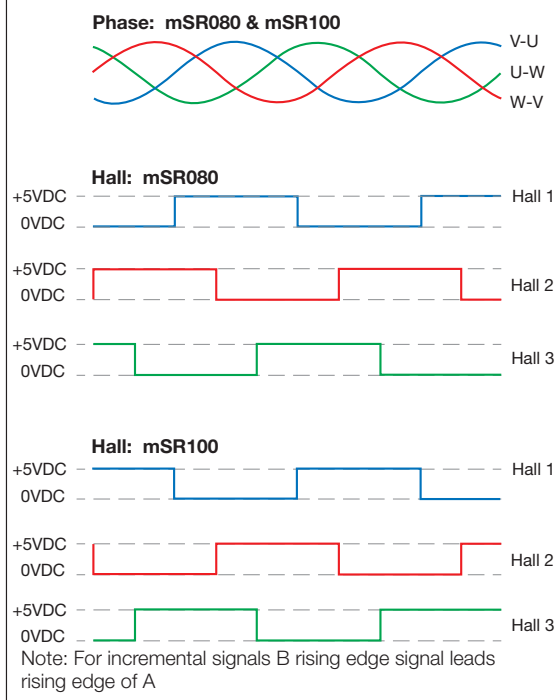

Motor and Hall Wiring

Function	Color	Pin #
Motor Phase U	Red	1
Motor Phase V	Brown	2
Motor Phase W	Orange	3
PE Ground	Green/Yellow	4
Hall Power (+5 Volts DC)	Black	5
Hall Ground	White	6
Hall 1	Yellow	7
Hall 2	Blue	8
Hall 3	Green	9

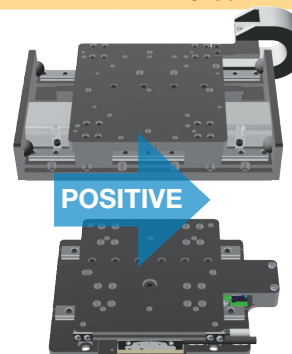

Drive/Control Solutions



The Intelligent Parker Amplifier or IPA, is a versatile servo drive/controller based on the ACR control platform.

The IPA provides a dual port Ethernet interface which gives the machine builder the flexibility needed to create cost effective motion control solutions.

The IPA operates as a fully programmable stand-alone motion controller with on-board I/O and virtual axis capability or can be integrated into a PLC or PC-based machine control solution.

Software tools are included to optimize motion performance and efficiently monitor and manage the application.

EtherNet/IP gives IPA users a popular connectivity option to PLCs for easy integration of servo motion in larger machine control application. The IPA is an EtherNet/IP adapter device supporting both I/O and Explicit Messaging. Add-On Instructions are available for seamless integration with Logix controllers.

Drivel Solutions



The P-Series drives operate with a variety of machine control architectures and offer sophisticated servo functionality. Accurate and easy to use inertia detection leads to fast set-up of tuning parameters and minimal settling time.

Advanced filtering and vibration suppression features can be used to increase throughput and improve positioning performance.

For high speed, real-time network applications, the P-Series is available with, EtherCAT, the fastest growing, most flexible industrial Ethernet protocol. Ideal for use with the Parker Automation Controller, the P-Series also follows the open standards for EtherCAT.

The Pulse version can be configured for step and direction control input and includes analog inputs for torque or velocity control. Select Indexer mode to create up to 64 position table entries triggered via inputs or over a RS422 interface.

Parker Drives and Cable Accessory Part Numbers

Encoder Type	Drive	Cable Interconnect Part Number
Digital	IPA	006-2690-01
Analog	IPA	006-2692-01
Digital	P Series	006-2691-01
Digital/Analog	Motor Power and Hall Flying Lead	006-2678-01
Digital	Digital Encoder Flying Lead	006-2679-01
Analog	Analog Encoder Flying Lead	006-2680-01

Optical Encoder

Function	Signal	Pin #
Power	5 Volts DC	8
	Ground	2, 9
Incremental Signals	A+	14
	A-	6
	B+	13
	B-	5
Reference Mark	Z+	12
	Z-	4
Limits	Positive Limit	11
	Negative Limit	10
Setup	(Used in installation)	1
Error Output	NPN	3

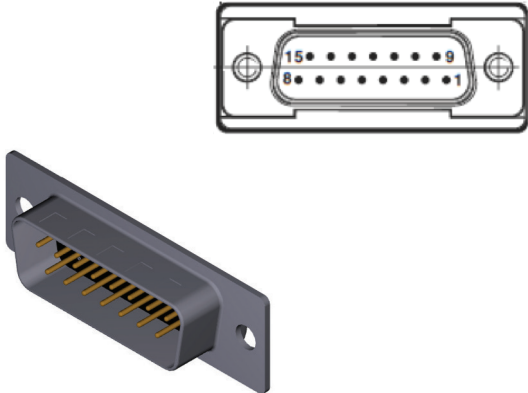

Sine Cosine Encoder

Function	Signal	Pin #
Power	5 Volts DC	4, 5
	0 Volts DC	12, 13
Incremental Signals	Cosine +	9
	Cosine -	1
	Sine +	10
	Sine -	2
Reference Mark	Z+	3
	Z-	11
Limits	Positive Limit	7
	Negative Limit	8
Setup	(Used in installation)	6
Remote Calibration	NPN	14

Magnetic Encoder

Function	Signal	Pin #
Power	5 Volts DC	8
	Ground	9
Incremental Signals	A +	14
	A -	6
	B +	13
	B -	5
Reference Mark	Z+	12
	Z-	4
Limits	Positive Limit	11
	Negative Limit	10
Home	NPN	2
Error Output	NPN	3

Miniature Positioners

BiSS-C Absolute Encoder (mSR100 only)

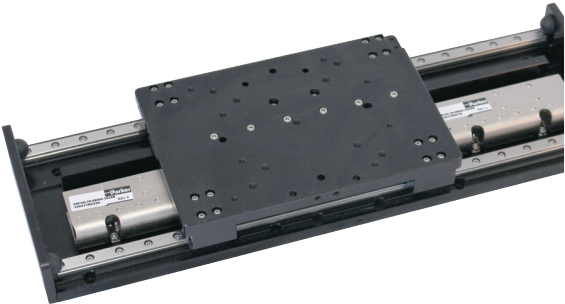

Function	Signal	Color
Power	5 Volts DC	Brown
	Ground	Green
		White
Serial Communications	MA+	Violet
	MA-	Yellow
	SLO+	Grey
	SLO-	Pink
Shield	Inner shield	-
	Outer	Case

Multi-axis Systems

The mSR series was designed to be highly modular, such that it can easily be configured into multi-axis systems made out of other mSR or MX80L positioners as the mSR80 uses the same bolt pattern. Since the entire mSR series was designed with this common hole pattern in mind, X-Y systems can be developed without the need for an additional transition plate.

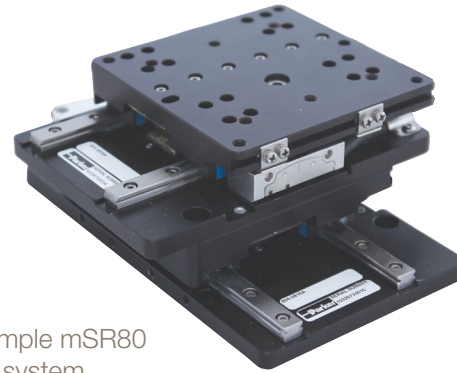

Example mSR80 X-Y system

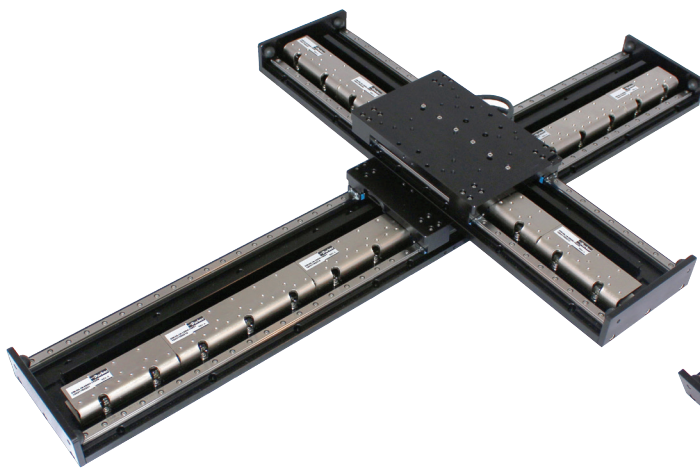

mSR100 X-Y standard orientation

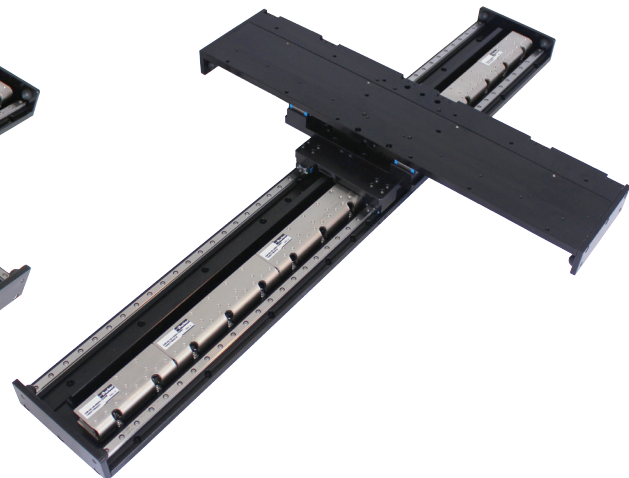

mSR100 X-Y carriage-to-carriage direct mount orientation

The mSR100 was designed such that it can be configured into two different X-Y orientations: one reflecting a standard X-Y design and the other with the carriages mounted directly to one another. If you choose to develop your machine with the carriage-to-carriage approach, the Y axis cable carrier is eliminated.

The mSR100 is also populated with mounting holes to mount an mSR80 directly to it so that X-Y, X-Z or X-Y-Z systems can be created with any combination of the mSR80 and mSR100. Pictured here is the mSR80 with a standard Z bracket.

mSR100 X with mSR80 Z including magnetic counterbalance

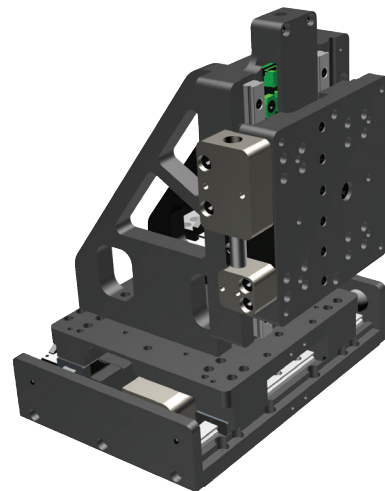

Z-Axis Brackets

mSR80 & mSR100	Part Number
25, 35, and 50 mm	002-2238-01
100 & 150 mm	002-2240-01

ORDERING INFORMATION

mSR100

Fill in an order code from each of the numbered fields to create a complete part number

①	②	③	④	⑤	⑥	⑦	⑧	⑨	⑩	⑪	
Order Example:	MSR	100	L	050	P	LS	E3	H1	L1	CM03	X0
① Series MSR Series					⑥ Motor LS Ironless, single LD Ironless, double (50 to 500 mm stroke only)				⑩ Cable Options CM03 No cable management, 3 meter CM13 Single cable carrier, 3 meter CM23 Double cable carrier, 3 meter *Cable length is given as length from carriage, it does not take into account any reduction in length due to cable management		
② Size (width in mm) 100 100 mm wide profile					⑦ Encoder E1 1μ optical incremental E2 0.1μ optical incremental E3 0.01μ optical incremental SC Sine/Cosine M1 1μ magnetic incremental R1 0.05μ BiSS-C Absolute				⑫ Other Options X0 No options		
③ Drive Train L Linear Motor Drive					⑧ Home Sensor H0 No home sensor (BiSS-C Absolute Only) H1 Home Sensor (M1 Option), Index Mark (E1, E2, E3, and SC Options)						
④ Stroke Length (mm) 025 25 mm 050 50 mm 100 100 mm 150 150 mm 200 200 mm 250 250 mm 300 300 mm 350 350 mm 400 400 mm 450 450 mm 500 500 mm					⑨ Limit Sensor L0 No limit sensor (BiSS-C Absolute Only) L1 End-of-travel limit sensors (Magnetic, Optical and Sine/Cosine only)						
⑤ Grade P Precision (Optical, Sine/Cosine, and BiSS-C Absolute only) S Standard (Magnetic Encoder only)											

Miniature Positioners

Free sizing and selection support
from Virtual Engineer at
parker.com/VirtualEngineer



MX80L

Linear Servo Motor Driven Stages

High performance in a small package

- Miniature size
- Fast settling
- Submicron precision
- High velocity (2 m/sec.)
- Multi-axis platform

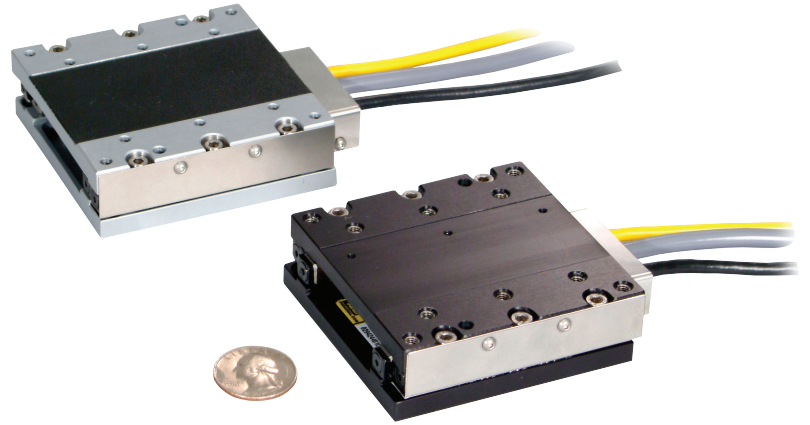

Attributes

- Low profile miniature size - (25 mm high X 80 mm wide)
- Linear servo motor drive
- Six linear encoder resolutions (0.01 μm to 5.0 μm)
- 25, 50, 100, 150 and 200 mm travels
- Cross Roller bearing (zero cage creep design)
- Precision or standard grade
- Cleanroom and low ESD options
- Fully adjustable home and limit sensors
- Dowel holes for repeatable mounting of payload
- Master reference surface to travel path
- “Plug-in” intelligent drive
- Pneumatic z-axis counterbalance
- No moving cables

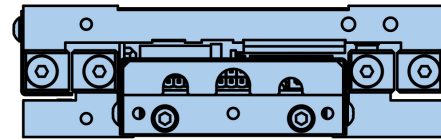

MX80L

MX80L Table

Duty Cycle	Max Acceleration	Max Load	Max Travel	Peak Force	Repeatability (+/-)
100%	5G	8KG	200mm	24N	0.4 μm

High Performance in a Small Package

Miniaturization of fiber optics, photonics, electronics and biomedical processes has driven the need for smaller and more efficient positioners. Parker’s MX80 miniature stage, the smallest linear servomotor driven positioner in the industry, is loaded with high-performance features for both rapid linear translation and precise positioning of lighter loads in small work envelopes.

Designed for today’s 24/7 production demands, the MX80 has redefined “high-throughput automation” in the world of miniature positioners.

While the MX80 is small in size, it is large on performance and reliability. All key components are “built-in” – residing within the body of the stage to provide a clean looking, reliable, unobstructed package.

At the heart of the MX80 is an innovative non-contact linear servo motor (patent pending). This direct drive motor has been optimized for force, speed, and acceleration, to deliver outstanding performance and response. A high-precision non-contact linear encoder provides submicron resolution, repeatability and accuracy.

Selectable resolutions range from 10 nanometers to 5 microns. Precision ground cross roller bearing sets with a “zero cage creep” feature provide extremely smooth, precise linear translation. Digital Hall effect travel limit and home sensors are conveniently designed into the unit for easy adjustment over the entire travel of the stage. Although there are no moving cables, a meter of high-flex cabling is included and wired directly into the units. This high-flex cabling addresses cable flexing concerns associated with the second or third axis in multi-axis system.

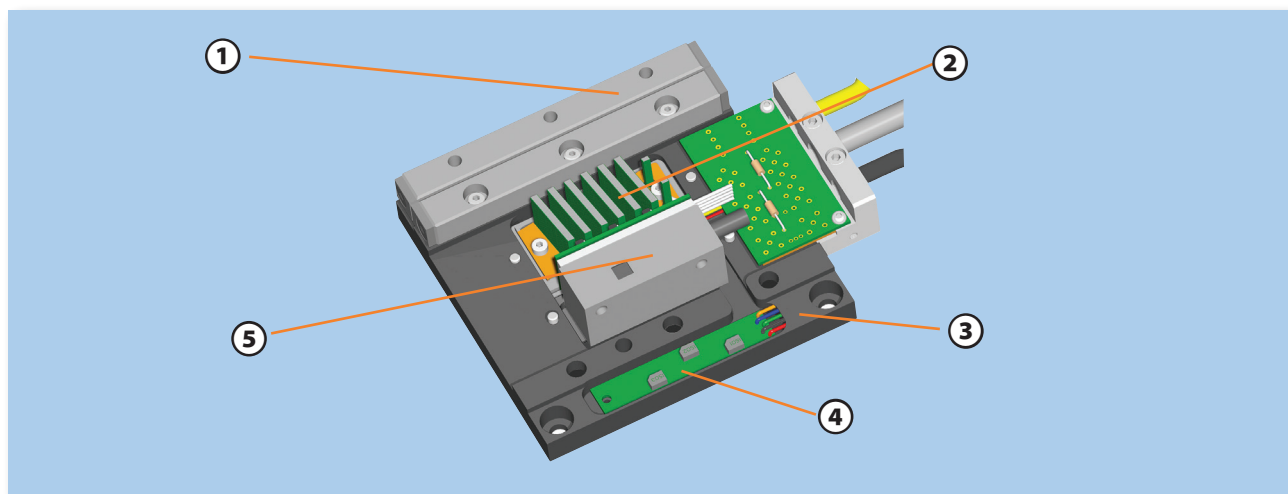

1 Cross Roller Bearings

provide high stiffness and extremely smooth linear translation. A rack and pinion anti-cage creep design within the bearing races prevents cage creep even at 5g acceleration, or with cantilevered loads.

2 Linear Servo Motor

features a patent pending ironcore design that provides high thrust density for linear acceleration to 5g's and velocities to 2 meters/second. The non-contact design offers long life and clean operation.

3 Master Reference Surface

is a feature unique to the MX80 that enables customers to align their process to the actual travel path within microns.

4 Home/Limit Sensors

are magnetic sensors completely housed within the body of the stage, and fully adjustable over the entire travel range.

5 Optical Linear Encoders

are available in six standard resolutions (10 nm, 20 nm, 0.1 μm , 0.5 μm , 1.0 μm , 5.0 mm) and are fully integrated within the body of the stage. The non-contact design offers long life and clean operation.

Miniature Positioners

Zero Cage Creep Feature

High acceleration and smooth translation are both desired attributes in a linear-motor stage. The cross roller bearing system found in the MX80 provides extremely smooth linear translation, and with an anti-cage creep design, operates very well in high acceleration applications. This design employs a rack and pinion feature within the bearing races to eliminate bearing creep. As a result, the MX80 performs well, even at 5g acceleration.

Tooling Features

Innovative tooling features make mounting and alignment much quicker and easier.

- A hardened steel master reference surface is provided along the side of the stage to allow fixturing or other tooling elements to be precisely aligned with the actual travel path.
- Two dowel pin holes are provided on the carriage top and base for repeatable mounting of positioner or tooling.

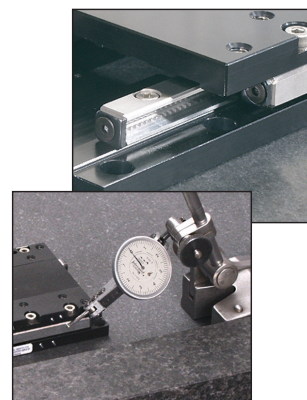

SPECIFICATIONS

Download 2D & 3D files from
www.parker.com/emn/MX80L



SPECIFICATIONS

The MX80L is a high performance linear servo motor stage designed to meet today's 24/7 production demands requiring rapid-fire positioning of light loads within a small work envelope.

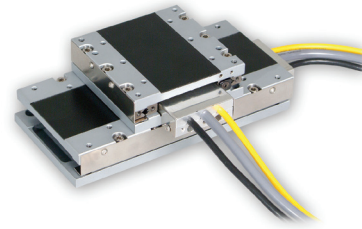

MX80LP Precision Grade					MX80LS Standard Grade					
Travel (mm)		25	50	100	150	25	50	100	150	200
Normal Load Capacity	kg (lb)	8 (18)	8 (18)	8 (18)	8 (18)	8 (18)	8 (18)	8 (18)	8 (18)	8 (18)
Maximum Acceleration	g-force	4	4	4	3	5	5	5	4	3
Maximum Velocity										
5.0 µm		1100	1500	2000	2000	1100	1500	2000	2000	2000
1.0 µm		1100	1500	2000	2000	1100	1500	2000	2000	2000
0.5 µm	mm/sec ²	1100	1500	1500	1500	1100	1500	1500	1500	1500
0.1 µm		300	300	300	300	300	300	300	300	300
0.02 µm		60	60	60	60	60	60	60	60	60
0.01 µm		30	30	30	30	30	30	30	30	30
Peak Force	N (lb)	12 (2.7)	12 (2.7)	24 (5.4)	24 (5.4)	12 (2.7)	12 (2.7)	24 (5.4)	24 (5.4)	24 (5.4)
Continuous Force	N (lb)	4 (0.9)	4 (0.9)	8 (1.8)	8 (1.8)	4 (0.9)	4 (0.9)	8 (1.8)	8 (1.8)	8 (1.8)
Duty Cycle	%	100	100	100	100	100	100	100	100	100
Straightness & Flatness	µm	4	4	5	6	6	6	10	12	14
Positional Accuracy*										
5.0 µm		13	14	15	15	25	30	35	35	35
1.0 µm		5	6	7	7	15	20	25	25	25
0.5 µm	µm	4	5	6	6	12	15	20	20	20
0.1 µm		3	4	5	5	12	15	20	20	20
0.02 µm		3	4	5	5	12	15	20	20	20
0.01 µm		3	4	5	5	12	15	20	20	20
Bi-directional Repeatability*										
5.0 µm		±10.0	±10.0	±10.0	±10.0	±10.0	±10.0	±10.0	±10.0	±10.0
1.0 µm		±2.0	±2.0	±2.0	±2.0	±2.0	±2.0	±2.0	±2.0	±2.0
0.5 µm	µm	±1.0	±1.0	±1.0	±1.0	±1.0	±1.0	±1.0	±1.0	±1.0
0.1 µm		±0.5	±0.5	±0.5	±0.5	±0.5	±0.5	±0.5	±0.5	±0.7
0.02 µm		±0.4	±0.4	±0.4	±0.4	±0.4	±0.4	±0.4	±0.4	±0.5
0.01 µm		±0.4	±0.4	±0.4	±0.4	±0.4	±0.4	±0.4	±0.4	±0.5
Unit Mass	g	590	590	1027	1345	475	475	875	1125	1370
Carriage Mass (unloaded)	g	282	282	509	676	213	213	405	537	695

* Notes:

(1) Measured at the carriage center, 35 mm above the mounting surface @ 20 C with no load. Unit bolted to granite surface, flat to within 1 micron/300 mm.

(2) Total accuracy and bi-directional repeatability over full travel (peak to peak).

(3) Precision grade with slope correction value provided. Consult factory if better accuracy is required.

(1) Total accuracy and bi-directional repeatability over full travel (peak to peak).

Force - Speed

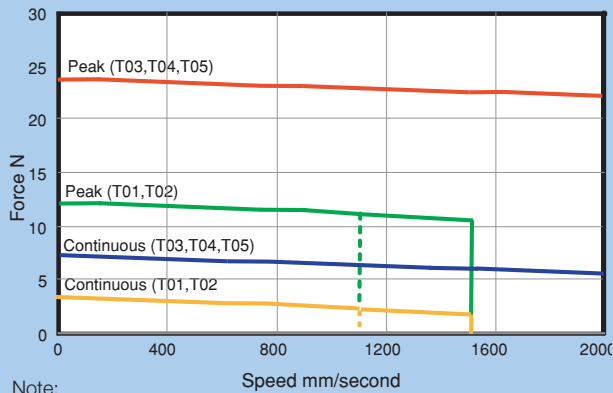

Note: T01 (25 mm travel) is limited to a maximum speed of 1100 mm/sec. T02 (50 mm) is limited to 1500 (due to limited travel).

Life - Load (Normal Load)

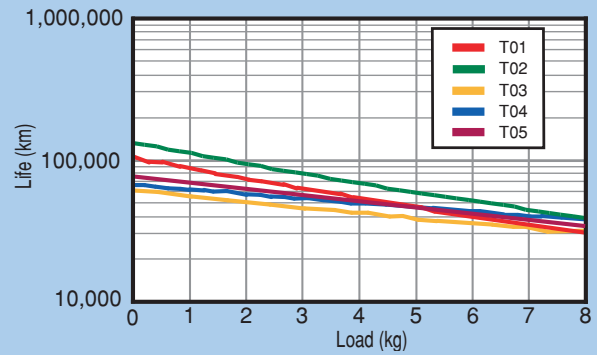

Distance vs Time

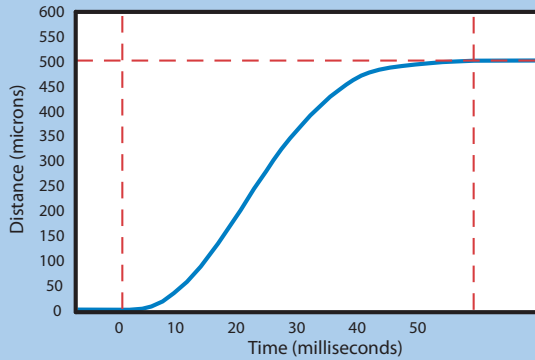

Note: 1 Kg payload, 500 micron move: Move and settle to within 1 micron in 47 milliseconds.

Velocity Ripple

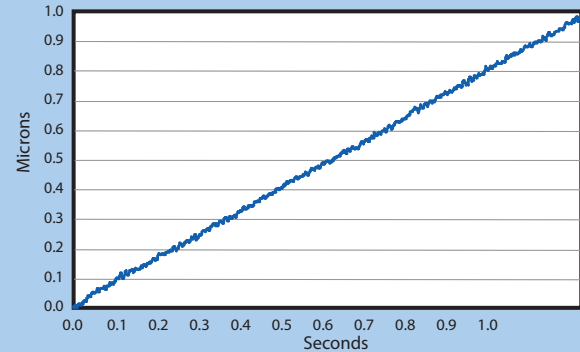

Note: Test were performed using a model MX80LT04D13E8 with a 20 nanometer linear encoder

Miniature Positioners

MX80LP Precision Series

Precision grade models are designed for high-performance applications requiring the highest degree of positioning accuracy. They offer a steel body design with precisely ground mounting surfaces & bearing ways. They include higher resolution linear encoders, and are slope corrected, laser tested and certified for optimum precision.

- 4 g acceleration
- Repeatability to $\pm 0.4 \mu\text{m}$
- Straightness $4 \mu\text{m}$
- Steel body construction
- Precision ground mounting and bearing surfaces
- Electroless nickel protective finish



MX80LS Standard Series

Standard grade units offer a lower cost alternative for applications requiring high throughput performance with less demanding positioning requirements. They are constructed of high alloy aluminum, providing a lighter weight design which can accelerate to 5 g.

- 5 g acceleration
- Repeatability to $\pm 0.8 \mu\text{m}$
- Straightness $6 \mu\text{m}$
- Steel body construction
- Lightweight aluminum body
- Low luster black anodize finish

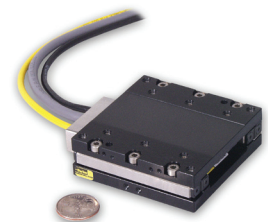

DIMENSIONS

Download 2D & 3D files from
www.parker.com/emn/MX80L



DIMENSIONS

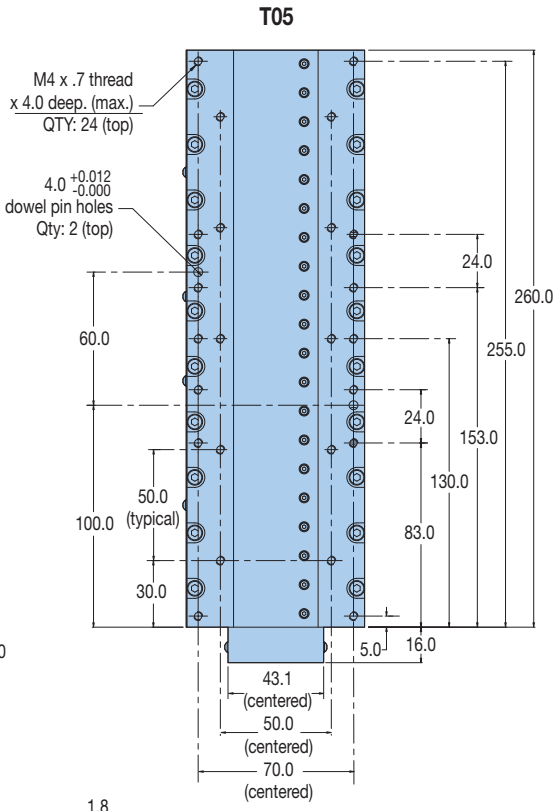
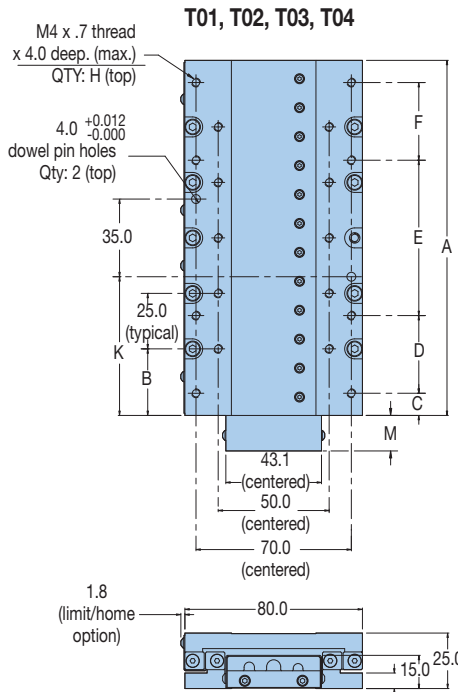

Dimensions – mm (in)

Z-axis

Travel	Dim Z
25	166
50	166
100	251
150	326
200	–

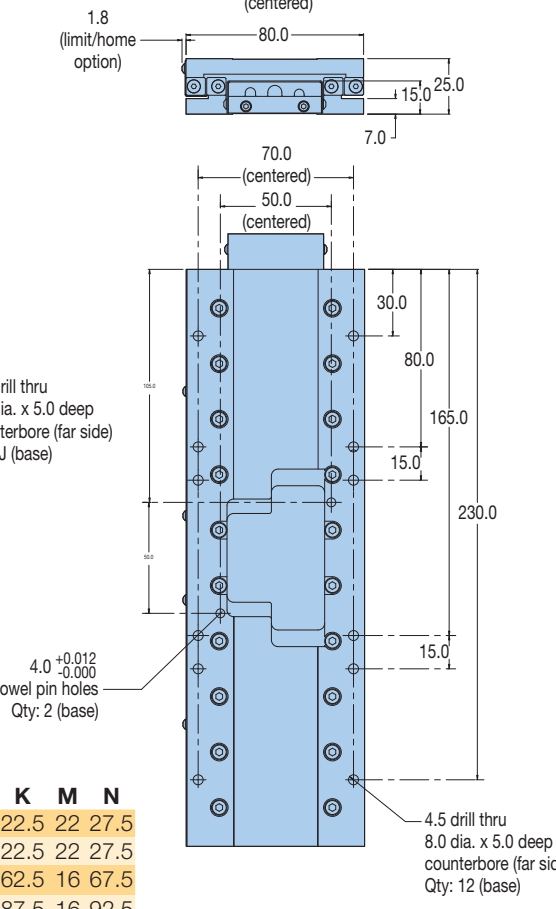
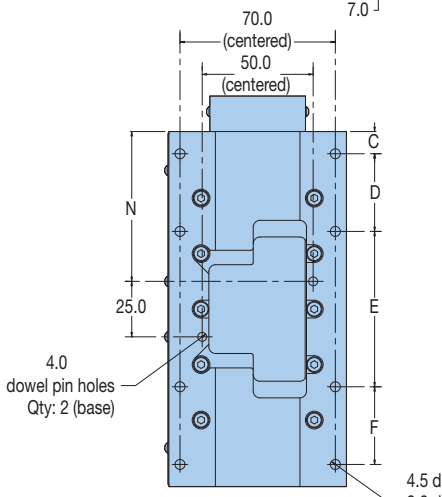

Pneumatic Vertical Axis Counter Balance

Travel	Dim X
25	156.6
50	156.6
100	230.6
150	310.6
200	–

Dimensions (mm)

Travel	A	B	C	D	E	F	H	J	K	M	N
25	80	15	5	70	–	–	10	4	22.5	22	27.5
50	80	15	5	70	–	–	10	4	22.5	22	27.5
100	160	30	10	35	70	35	18	8	62.5	16	67.5
150	210	30	5	65	70	65	22	8	87.5	16	92.5

Simple Configuration Digital Drive Options

All digital drives ordered in the MX80 part number configuration come set up with a motor file including electrical parameters to set continuous and peak currents, current loop compensation values, and default gain settings. Users will have the ability to override these parameters for special application requirements.

Tuning is easy and intuitive for users and is available via a variety of methods. The motor and loading information must be known by the drive to determine the baseline tuning gains. These are simple parameter entries the user can complete with the help of standard Parker supplied front-end software tools. Seamless integration of drives and controls ensures performance matched functionality of the completed motion system.

Servo & Microstepping Drives/Controllers

Parker servo and microstepping drives are the perfect drive solution to be paired with the MX80 family. We are happy to assist with the selection of a suitable drive.

For complete details on drive product features and specifications, please refer to the “Drives & Controllers” section of this catalog.

Encoder Options

Order Codes: E2 E3 E4 E5 E8 E9

A non-contact linear optical encoder provides a quadrature output and offers resolution ranging from 10 nanometer to 5 micron. On the MX80L, the encoder is internal to the stage body. There is no increase to the footprint of the unit and no additional external cabling is required.

Home and Limit Sensor Options

Order Codes: H1 H2 H3 L1 L2 L3

Magnetic home and limit sensors are completely housed within the body of the stage. An innovative design adds functionality without sacrificing geometry. Sensor triggers can be easily adjusted over the travel. The output format is an open collector type capable of sinking up to 50 mA, and be set as N.O. or N.C.

“Plug & Play” Cable Options

User convenience is high on the list of cable attributes found in the MX80. The high-flex cabling and connectors are reliable, durable and offer easy hook-up for “plug and run” installation.

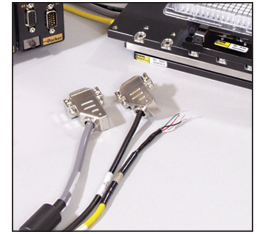

- **High-flex cables**
- **CE compliant connectors and shielding**
- **CE compliant ferrite beads**
- **Color coded jackets and labeling**
- **Connectors simplify installation**

Cable Connector Configuration

HD15M-VF		HD15F-VL	
15 Pin HD-SUB Plug		15 Pin HD-SUB Rcpt	
Pin #	Function	Pin #	Function
1	Z+	1	GND
2	Z-	2	NO CONN-
3	GND	3	NO CONN
4	NO CONN	4	NO CONN
5	+5V	5	NO CONN
6	GND	6	+LIMIT
7	A-	7	-LIMIT
8	A+	8	HOME
9	HALL1	9	NO CONN
10	TEMP	10	NO CONN-
11	B-	11	NO CONN
12	B+	12	NO CONN
13	HALL2	13	NO CONN
14	HALL3	14	NO CONN
15	NO CONN	15	NO CONN

HD15M-VF Connector compatible with IPA, Vix and Aries Feedback Connector

HD15M-VL Connector compatible with Vix Limit/Home Connector

Miniature Positioners

Cleanroom Option

Order Codes: R2 R20

Both precision and standard grade products can be prepared for cleanroom compatibility.

Preparation involves material changes, element modification and cleanroom compatible lubricants. MX80L and MX80S stages with this option are class 10 cleanroom compatible. When applying an XY or XYZ combination in a cleanroom environment, moving wires need to be considered – please consult a Parker application engineer.

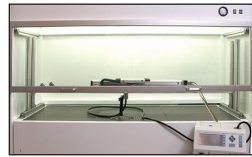

Low ESD Coating Option

Order Codes: R10 R20

An optional low ESD electroless nickel or Armoloy coating is offered for improved electrically conductivity, providing a low resistance to ground path for electric discharge.

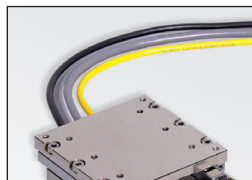

Environmental Protection Option

Both precision and standard grade units have a hard coat protective finish. The precision units have a hard coat (Rc 78) satin chrome finish, and the standard units have a low luster black anodized finish.

System Orthogonality Option

Order Codes: S2 S3 S4 S5 S6

In any multi-axis positioning system, the perpendicular alignment of the axes must be clearly specified. “Degree of orthogonality” defines the perpendicular alignment of axis one to another. The MX80 offers two choices for orthogonality. As standard, perpendicularity is held to within 60 arc seconds. For more exacting applications the MX80 can be optioned for 15 arc seconds orthogonality.

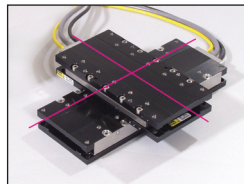

Z-axis Counterbalance Option

Order Codes: X2

A pneumatic Z-axis counterbalance is offered to prevent a sudden load drop if power to the motor is interrupted. A controlled vertical force is applied to the stage top to negate the effect of gravity and achieve equilibrium. A precisely regulated clean air supply of 0 to 60 psi is required for operation. (See Pneumatic Accessory Package.)

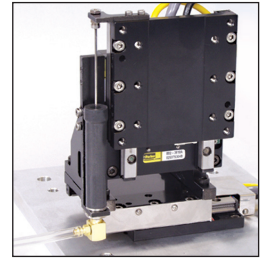

Pneumatic Accessory Package

This accessory is offered for use with the pneumatic counterbalance option. It consists of a pre-filter, a pressure regulator, a coalescing filter, and a precision regulator to precisely regulate air pressure and remove oil, water or debris down to 3 microns.

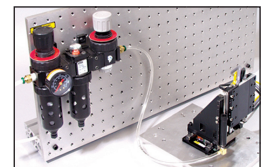

Part Number: 002-2236-01

Z-Axis Bracket Accessory

Lightweight aluminum Z-brackets are available for easy construction of vertical axis combinations.

Standard Model Part Numbers:

25 & 50 mm: 002-2238-01
100 & 150mm: 002-2240-01

Low ESD Model Part Numbers:

5 & 50 mm: 002-2239-01
100 & 150 mm: 002-2241-01

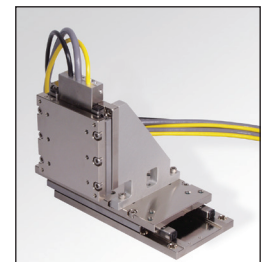

ORDERING INFORMATION

MX80L

Fill in an order code from each of the numbered fields to create a complete model order code.

① ② ③ ④ ⑤ ⑥ ⑦ ⑧ ⑨ ⑩ ⑪ ⑫ ⑬ ⑭

Order Example: MX80L T02 M P -D11 H3 L2 CM05 Z3 E8 R1 A25 X1 S1

- | | |
|--|--|
| <p>① Series
MX80L</p> <p>② Travel – mm
T01 25
T02 50
T03 100
T04 150</p> <p>③ Mounting
M Metric</p> <p>④ Grade
S Standard
P Precision (not available with T05 Travel option)</p> <p>⑤ Drive Type
D1 Free Travel (No Motor)
D11 4 Pole (25 & 50 mm travel only)
D13 8 Pole (100, 150 & 200 mm travel only)</p> <p>⑥ Home Sensor
H1 None-Free Travel (only)
H2 N.C. Current Sinking
H3 N.O. Current Sinking</p> <p>⑦ Limit Sensor
L1 None-Free Travel (only)
L2 N.C. Current Sinking
L3 N.O. Current Sinking</p> <p>⑧ Cable Options
CM03 No Cables – Free Travel
CM04 1m High-Flex Cables w/ HD15M-VF & HD15M-VL Connectors
CM05 3m High-Flex Cables w/ HD15M-VF & HD15M-VL Connectors
CM06 1m High-Flex Cables w/ HD15M-VF Connector, w/ out limit cable
CM07 3m High-Flex Cables w/ HD15M-VF Connector, w/ out limit cable</p> | <p>⑨ Z Channel Location
Z1 None
Z3 Center Position</p> <p>⑩ Digital Linear Encoder Option
E1 None
E2 1.0 µm Resolution
E3 0.5 µm Resolution
E4 0.1 µm Resolution
E5 5.0 µm Resolution
E7 Sine output encoder
E8 0.02 µm Resolution (20 nanometer)
E9 0.01 µm Resolution (10 nanometer)</p> <p>⑪ Environmental
R1 Standard Finish (black anodized)
R2 Cleanroom Prep
R10 Low ESD Finish
R20 Low ESD Finish & Cleanroom Prep</p> <p>⑫ Digital Drive
A1 No Drive</p> <p>⑬ Other Options
X1 None
X2 Z-axis Pneumatic Counter Balance*
* Not available with T05 Travel.</p> <p>⑭ Axis Designator
S1 None (single-axis)
S2* X-axis base unit (cables @ 12 o'clock)
S3* Y-axis 60 arc-sec (cables @ 3 o'clock)
S4* Y-axis 60 arc-sec (cables @ 9 o'clock)
S5* Y-axis 15 arc-sec (cables @ 3 o'clock)
S6* Y-axis 15 arc-sec (cables @ 9 o'clock)</p> |
|--|--|

Notes - HD15M-VF Connector compatible with IPA, Vix and Aries Feedback Connector
HD15M-VL Connector compatible with Vix Limit/Home Connector

Miniature Positioners

Free sizing and selection support
from Virtual Engineer at
parker.com/VirtualEngineer



MX80S Ballscrew and Leadscrew Driven Stages

Reliable, low profile miniature positioner

- Cross roller bearing (zero cage creep option)
- Stepper or servo motor drive
- Digital limit/home system
- Optional linear encoder
- Cleanroom prep. option

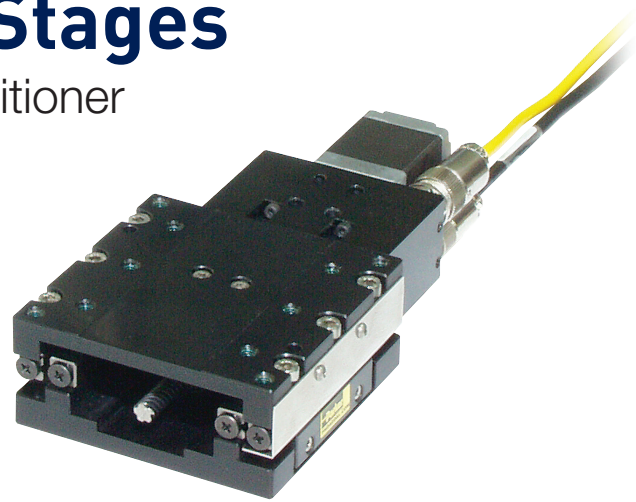

- Miniature Size - Low Profile (35 mm high X 80 mm wide)
- Normal or cleanroom environments
- 25, 50, and 100 mm travels
- Multi-axis platform
- Ballscrew or leadscrew drive options

MX80S Table

Duty Cycle	Max Acceleration	Max Load	Max Travel	Peak Force	Repeatability (+/-)
100%	2 G	8 kG	100 mm	123 N	1.5 μ m

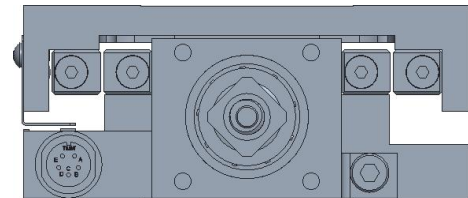

MX80S

The MX80S miniature positioner is the screw driven member of Parker's MX80 and mSR family. Like its counterparts, the MX80L, mSR80, and mSR100 linear motor-driven stages, and the MX80M manual stage, the MX80S is designed for applications requiring reliable linear positioning in space restricted applications. It is the complementary product that provides easy mounting compatibility where screw driven stage performance is ideal for the application.

The MX80S can be supplied with a high-efficiency leadscrew drive capable of reaching 200 mm per

second velocity, or a precision ground ballscrew drive offering axial thrust to 123 N.

The leadscrew drive employs a PTFE coated leadscrew with a preloaded nut to produce extremely smooth linear translation. A choice of three leads provides improved opportunity for matching desired velocity/resolution requirements.

The 2.0 mm lead ballscrew stage offers high performance 24/7 operation with a thrust load capacity of 123 N (28 lb) and velocity to 100 mm/second at 100% duty cycle.



Leadscrew drive



Ballscrew drive

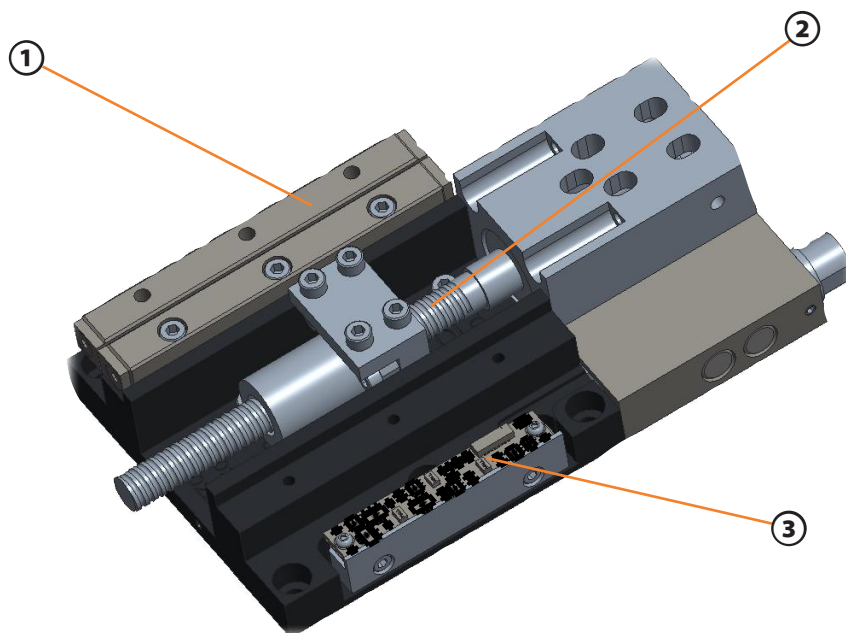

① Cross Roller Bearings

provide high stiffness and extremely smooth linear translation. A rack and pinion anti-cage creep design within the bearing races prevents cage creep even at 5 g acceleration, or with cantilevered loads.

② Ballscrew or leadscrew drive

The 2.0 mm lead ballscrew driven stage offers high performance 24/7 operation with a thrust load capacity of 123 N (28 lb.) and velocity to 100 mm/second at 100% duty cycle. Leadscrew driven stages are available with 1 mm, 2 mm, or 10 mm leads. The PTFE coated leadscrew provides extremely smooth linear translation at velocities up to 200 mm/second.

③ Home/Limit Sensors

are magnetic sensors completely housed within the body of the stage, and fully adjustable over the entire travel range.

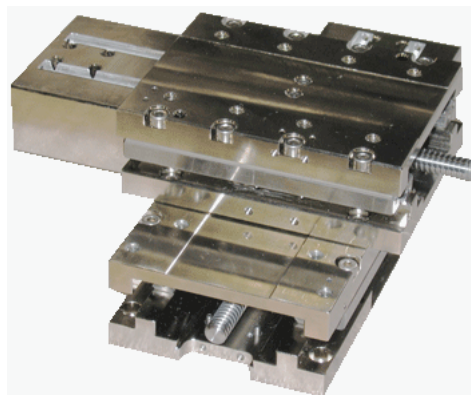

SPECIFICATIONS

The MX80S low profile miniature positioner offers reliable linear positioning for space restricted applications. Various screw and drives options are available to best suit the application's needs.

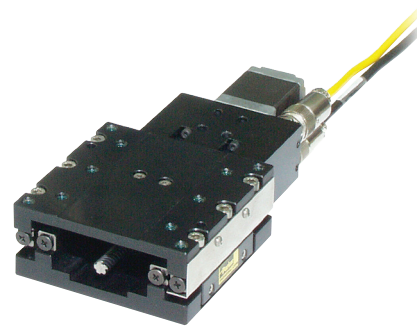

		MX80S Leadscrew Drive			MX80S Ballscrew Drive		
Travel (mm)		25	50	100	25	50	100
Normal Load Capacity	kg (lb)	8 (18)	8 (18)	8 (18)	8 (18)	8 (18)	8 (18)
Thrust Load Capacity	N (lb)	44 (10)	44 (10)	44 (10)	123 (28)	123 (28)	123 (28)
Maximum Velocity							
1.0 mm lead	mm/sec	20	20	20	—	—	—
2.0 mm lead		40	40	40	100	100	100
10.0 mm lead		200	200	200	—	—	—
Breakaway Torque	Nm	0.029	0.029	0.033	0.050	0.050	0.050
Running Torque							
1.0 mm lead	Nm	0.028	0.028	0.032	—	—	—
2.0 mm lead		0.028	0.028	0.032	0.047	0.047	0.047
10.0 mm lead		0.028	0.028	0.032	—	—	—
Duty Cycle	%	50	50	50	100	100	100
Straightness & Flatness*	µm	8	12	16	8	12	16
Positional Accuracy*							
1.0 mm lead	µm	30	45	75	—	—	—
2.0 mm lead		30	45	75	10	15	18
10.0 mm lead		35	50	80	—	—	—
Bi-directional Repeatability*							
1.0 mm lead	µm	±5.0	±5.0	±5.0	—	—	—
2.0 mm lead		±5.0	±5.0	±5.0	±1.5	±1.5	±1.5
10.0 mm lead		±10.0	±10.0	±10.0	—	—	—
Inertia (without motor & coupling)							
1.0 mm lead	10 ⁻⁷ kg-m ²	1.47	1.47	2.42	—	—	—
2.0 mm lead		1.62	1.62	2.68	4.19	4.19	6.08
10.0 mm lead		6.34	6.34	11.30	—	—	—
Screw Speed (max)	rps	20	20	20	50	50	50
Leadscrew Efficiency							
1.0 mm lead	%	40	40	40	—	—	—
2.0 mm lead		59	59	59	90	90	90
10.0 mm lead		78	78	78	—	—	—
Screw Diameter	mm	6.35	6.35	6.35	8.00	8.00	8.00
Bearing Coefficient of Friction		0.003	0.003	0.003	0.003	0.003	0.003
Unit Mass							
Table only	g	597	597	1003	694	694	1114
With 2-stack stepper		748	748	1154	845	845	1265
Carriage Mass (unloaded)	g	194	194	353	291	291	464

* Notes:

(1) Measured at the carriage center, 35 mm above the mounting surface @ 20 C with no load. Unit bolted to granite surface, flat to within 1 micron/300 mm.
 (2) Total accuracy and bi-directional repeatability over full travel (peak to peak).

(1) Measured at the carriage center, 35 mm above the mounting surface @ 20 C with no load. Unit bolted to granite surface, flat to within 1 micron/300 mm.
 (2) Total accuracy and bi-directional repeatability over full travel (peak to peak).
 (3) Repeatability valid with M21 servo motor.

Simple Configuration Digital Drive Options

All digital drives ordered in the MX80 part number configuration come set up with a motor file including electrical parameters to set continuous and peak currents, current loop compensation values, and default gain settings. Users will have the ability to override these parameters for special application requirements.

Tuning is easy and intuitive for users and is available via a variety of methods. The motor and loading information must be known by the drive to determine the baseline tuning gains. These are simple parameter entries the user can complete with the help of standard Parker supplied front-end software tools. Seamless integration of drives and controls ensures performance matched functionality of the completed motion system.

Servo & Microstepping Drives/Controllers

Parker servo and microstepping drives are the perfect drive solution to be paired with the MX80 family. We are happy to assist with the selection of a suitable drive.

Encoder Options

Order Codes: E2 E3 E4 E5

A non-contact linear optical encoder provides a quadrature output and offers resolution ranging from 10 nanometer to 5 micron. On the MX80L, the encoder is internal to the stage body. There is no increase to the footprint of the unit and no additional external cabling is required.

Plug & Play” Cable Options

Order Codes: CM02 CM03 CM04 CM05 CM06 CM07 CM08 CM09 CM10 CM11 CM12 CM13 CM15 CM17 CM18 CM19

“User convenience” is high on the list of cable attributes found in the MX80. The high-flex cabling and connectors are reliable, durable and offer easy hook-up for “plug and run” installation.

- **High-flex cables**
- **CE compliant connectors and shielding**
- **CE compliant ferrite beads**
- **Color coded jackets and labeling**
- **Connectors simplify installation**

Cable Connector Configuration

HD15M-VF 15 Pin HD-SUB Plug		HD15F-VLPR 15 Pin HD-SUB Rcpt	
Pin #	Function	Pin #	Function
1	Z+	1	GND
2	Z-	2	
3	GND	3	NO CONN
4	NO CONN	4	NO CONN
5	+5V	5	NO CONN
6	GND	6	+LIMIT
7	A-	7	-LIMIT
8	A+	8	HOME
9	HALL1	9	NO CONN
10	TEMP	10	NO CONN
11	B-	11	+24V to 560 Ohm Res
12	B+	12	NO CONN
13	HALL2	13	NO CONN
14	HALL3	14	NO CONN
15	NO CONN	15	NO CONN
HD15M-VF Connector compatible with IPA, Vix and Aries Feedback Connector		HD15F-VLPR Connector compatible with Vix Limit/Home Connector	

Home and Limit Sensor Options

Order Codes: H2L2 H2L3 H3L2 H3L3

Magnetic home and limit sensors are completely housed within the body of the stage. An innovative design adds functionality without sacrificing geometry. Sensor triggers can be easily adjusted over the travel. The output format is an open collector type capable of sinking up to 50 mA, and be set as N.O. or N.C.

For complete details on drive product features and specifications, please refer to the “Drives, Motors, Gearheads, & Controllers” section of this catalog.

Cleanroom Option

Order Codes: R2

Both precision and standard grade products can be prepared for cleanroom compatibility. Preparation involves material changes, element modification and cleanroom compatible lubricants. MX80L and MX80S stages with this option are class 10 cleanroom compatible. When applying an XY or XYZ combination in a cleanroom environment, moving wires need to be considered – please consult a Parker application engineer.

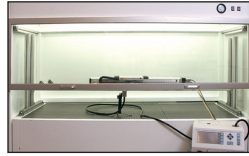

Low ESD Coating Option

(Available via customization only)

An optional low ESD electroless nickel or Armoloy coating is offered for improved electrical conductivity, providing a low resistance to ground path for electric discharge.

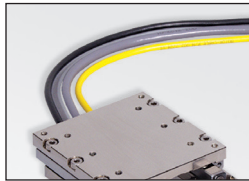

Environmental Protection Option

All units are standard with low luster black anodize finish. Other protective coatings are available to meet your application requirements.

System Orthogonality Option

(Available via customization only)

In any multi-axis positioning system, the perpendicular alignment of the axes must be clearly specified. “Degree of orthogonality” defines the perpendicular alignment of axis one to another. The MX80s offer two choices for orthogonality. As standard, perpendicularity is held to within 60 arc seconds. For more exacting applications the MX80 can be optioned for 15 arc seconds orthogonality.

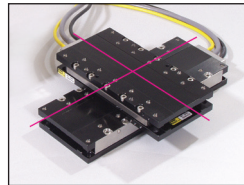

Z-Axis Bracket Accessory

Lightweight aluminum Z-brackets are available for easy construction of vertical axis combinations.

Standard Model Part Numbers:

25 & 50 mm: 002-2238-01
100 mm: 002-2240-01

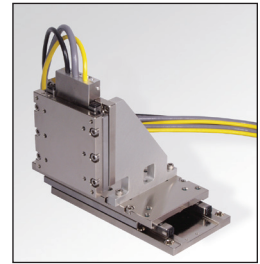

ORDERING INFORMATION

MX80S

Fill in an order code from each of the numbered fields to create a complete model order code.

① ② ③ ④ ⑤ ⑥ ⑦ ⑧ ⑨ ⑩ ⑪ ⑫ ⑬ ⑭ ⑮

Order Example: MX80S T04 M P K – D1 M1 H3L3 CM12 E1 Z1 R1 A11 X1 S1

- ① **Series**
MX80S
- ② **Travel – mm**
T01 25
T02 50
T03 100
- ③ **Mounting**
M Metric
- ④ **Grade**
S Standard
P Precision*
* Must order E3 or E4 Digital Option to meet catalog specification.
- ⑤ **Bearing Type**
K ACS Cross Roller
- ⑥ **Drive Type**
D1 1 mm Leadscrew ⁽¹⁾
D2 2 mm Leadscrew ⁽¹⁾
D3 10 mm Leadscrew ^(1,3)
D6 2 mm Ballscrew ^(2,3)
(1) Standard grade only (2) Precision grade only
(3) Not available with 1- or 2-stack stepper motor.
- ⑦ **Motor**
M0 No motor, flange, coupling
M15 Stepper, 2 stack, NEMA 11
M16 Stepper, 3 stack, NEMA 11
M21 Servo, 1 stack, NEMA 16
N11 NEMA 11 mtr mount with 5mm bore coupling
N16 BE16 mtr mount with .250" bore coupling
N17 Nema 17 mtr mount with 5 mm bore coupling
N31 PM-FAL mtr mount with 8 mm bore coupling
- ⑧ **Home/Limit Switch***
H1L1 None
H2L2 N.C. Home/N.C. Limit
H2L3 N.C. Home/N.O. Limit
H3L2 N.O. Home/N.C. Limit
H3L3 N.O. Home/N.O. Limit
*NC = Normally Closed; NO = Normally Open
- ⑨ **Cable Options (High-flex)**
CM01 None
CM02 Limits (only) w/Flying Leads (1m)
CM03 Limits (only) w/Flying Leads (3m)
CM04 Limit cable (1m) only w HD15M-VL connector
CM05 Limit cable (3m) only w/HD15M-VL connector
CM06 Stepper Motor (Flying Leads) & Limits with HD15M-VL Connector (1m)
- ⑩ **Digital Option**
E1 None
E2 1.0 µm Resolution
E3 0.5 µm Resolution
E4 0.1 µm Resolution
E5 5.0 µm Resolution
- ⑪ **Z Channel Location**
Z1 None
Z3 Center Position
- ⑫ **Environmental**
R1 Standard Finish (black anodized)
R2 Cleanroom Prep (Only available if Drive Type D6 (2mm ballscrew) is selected)
- ⑬ **Digital Drive**
A1 No Drive
- ⑭ **Axis Designator**
S1 None (single-axis)
S2* X-axis base unit (cables @ 12 o'clock)
S3* Y-axis 60 arc-sec (cables @ 3 o'clock)
S4* Y-axis 60 arc-sec (cables @ 9 o'clock)
S5* Y-axis 15 arc-sec (cables @ 3 o'clock)
S6* Y-axis 15 arc-sec (cables @ 9 o'clock)
*Consult factory for multi-axis pinning options and quotation
- ⑮ **Required Designator**
X1

Cable Options continued next column

MX80M Free Travel and Micrometer Driven Stages

Manual stage with precision control

The MX80M stages are offered as free travel or micrometer driven units with 25 mm or 50 mm travel. They include innovative tooling features to make mounting and precision alignment quicker and easier. A hardened steel master reference surface is provided along the side of the stage to allow fixturing or other tooling elements to be precisely aligned with the actual travel path. Dowel pin holes are provided on the carriage top for repeatable mounting or tooling. Also available are custom features such as a steel body design, vacuum prepped units, and anti cage creep bearings for high-dynamic applications up to 150 mm travel.



- Precision cross roller bearings
- Optional cleanroom prep.
- Optional low ESD coating
- Dowel holes in top & base
- Interchangeable mounting with motorized MX80 models
- Positive position lock

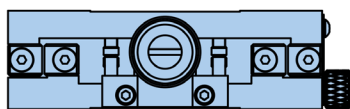

MX80M Center Drive with Micrometer

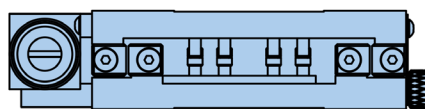

MX80M Side Drive with Micrometer

Miniature Positioners

SPECIFICATIONS

Completing the MX80 family, the MX80M is a manual stage with a black anodized aluminum body. The stage can be ordered with or without various micrometer options to best fit the needs of the application.



		MX80M Free Travel		MX80LM Micrometer Driven	
Travel (mm)		25	50	25	50
Normal Load Capacity	kg (lb)	20 (44)	20 (44)	20 (44)	20 (44)
Axial Force ⁽¹⁾					
F _a	kg	—	—	4.5	4.5
F _b		—	—	0.6	1.0
Straight Line Accuracy (per 25 mm travel)	µm	2	2	2	2
Micrometer Resolution					
0.001 in		—	—	Yes	Yes
0.01 mm		—	—	Yes	Yes
Digital Micrometer					
0.00005 in		—	—	Yes	Yes
0.001 mm		—	—	Yes	Yes

⁽¹⁾ Fa (force acting against micrometer)
Fb (force acting against spring)

DIMENSIONS

Download 2D & 3D files from
www.parker.com/emn/MX80M



DIMENSIONS

Free Travel (with position lock)

Dimensions – mm (in)

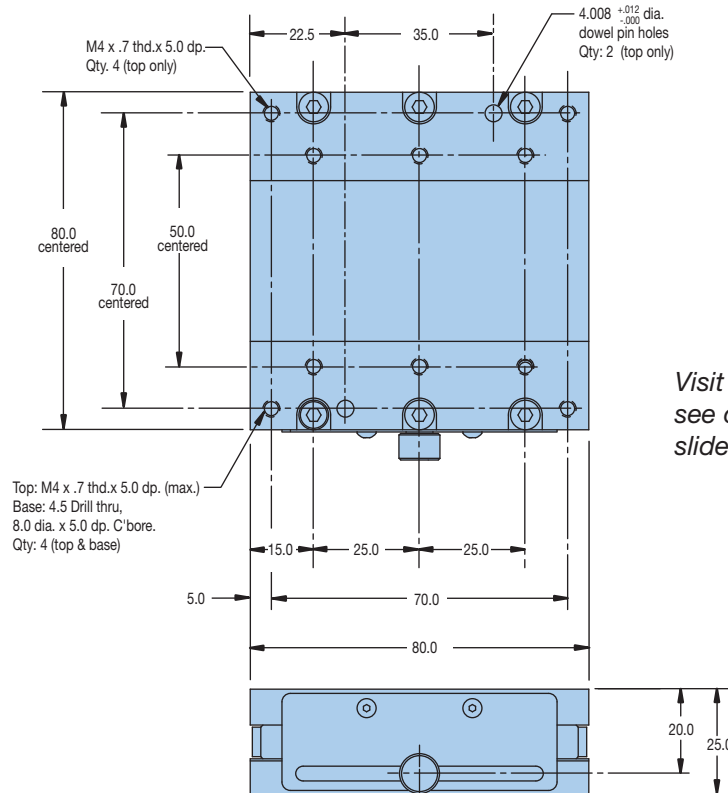

Visit Parker.com/emdusa to see other manual stage and slide options available!

Digital Micrometer (side drive shown)

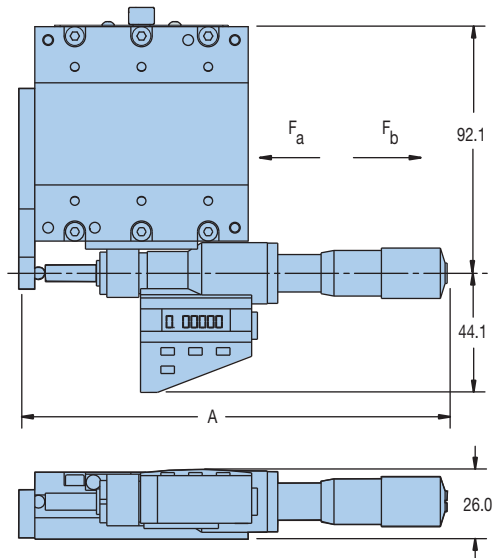

Standard Micrometer (center drive shown)

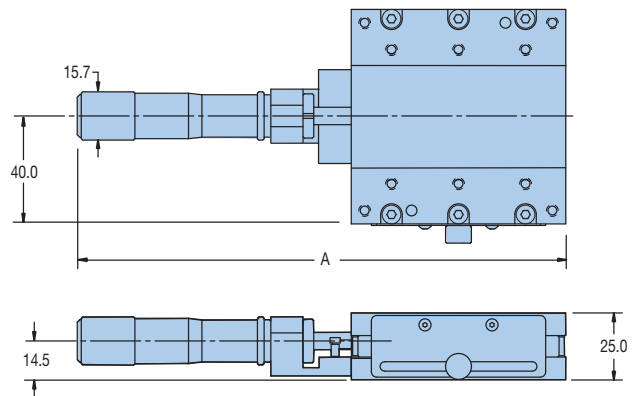

Drive Orientation	Travel	Dimension A (mm)
Center	25	225.6
	50	273.5
Side	25	160.6
	50	209.5

Center	25	182.2
	50	231.4
Side	25	117.2
	50	167.4

ORDERING INFORMATION

MX80M

Fill in an order code from each of the numbered fields to create a complete model order code.

① ② ③ ④ ⑤ ⑥ ⑦ ⑧ ⑨

Order Example: MX80M T02 M - S C2 D22 R1 X4 S1

① **Series**
MX80M

② **Travel – mm**
T01 25
T02 50

③ **Mounting**
M Metric

④ **Grade**
S Standard

⑤ **Style**
C1 Free Travel
C2 Center Drive
C3 Side Drive

⑥ **Drive Type**
D1 None
D20 Metric Micrometer
D21 English Micrometer
D22 Digital Micrometer

⑦ **Environmental**
R1 Standard Finish (black anodized)
R2 Cleanroom Prep
R10 Low ESD Finish
R20 Low ESD Finish & Cleanroom Prep

⑧ **Lock Options**
X1 No Lock
X4 With Lock

⑨ **Axis Designator**
S1 None (single-axis)
S2* X-axis base unit (micrometer @ 12 o'clock)
S3* Y-axis 60 arc-sec (micrometer @ 3 o'clock)
S4* Y-axis 60 arc-sec (micrometer @ 9 o'clock)
S5* Y-axis 15 arc-sec (micrometer @ 3 o'clock)
S6* Y-axis 15 arc-sec (micrometer @ 9 o'clock)

*Consult factory for multi-axis pinning options and quotation

Miniature Positioners

Free sizing and selection support
from Virtual Engineer at
parker.com/VirtualEngineer



MX45S Linear Positioning Stages

Single and multi-axis, ultra-miniature, high-performance positioners

- Ultra-compact profile (25 mm high X 45 mm wide x 65, 75 or 90 mm long)
- 5, 15 and 25 mm travels
- Ballscrew or leadscrew drive options
- Anti-cage creep crossed roller bearings
- Up to 40 N axial thrust
- 30 mm/s max velocity

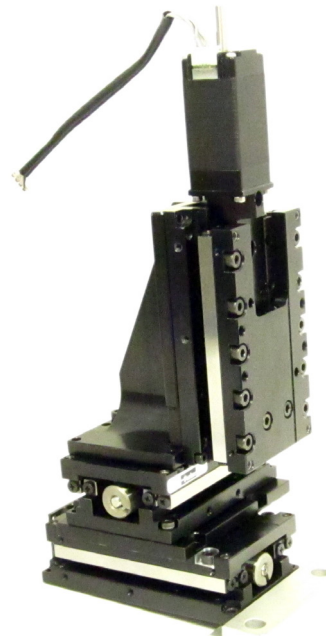

- Stepper motor driven
- Optional digital limit/home sensor pack
- Optional rotary or linear encoders
- Multi-axis platforms
- Ideal for normal or cleanroom environments

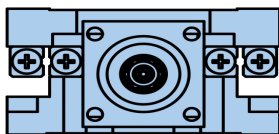
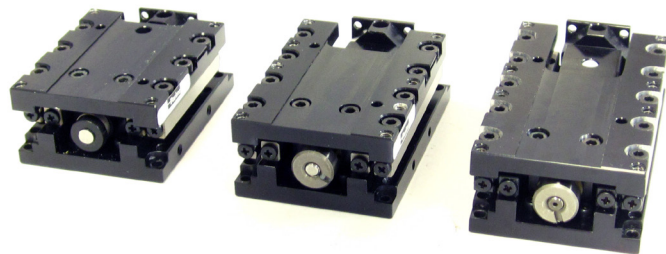

MX45S

MX45S Table

Duty Cycle	Max Acceleration	Max Load	Max Travel	Positional Accuracy	Repeatability (+/-)
100%	2G	7KG	25mm	6µm	1.0µm

The MX45S is a 45mm wide miniature screw driven positioner based on the award-winning MX80 family. Like its predecessor, the MX45S is designed for OEMs requiring reliable linear positioning in space restricted applications. Designed with anti-cage creep crossed roller bearings, the MX45S allows users to position up to 7 kg of normal load on the stage's three standard travel lengths (5mm, 15mm & 25mm).

The MX45S can be supplied with a high efficiency leadscrew or a high precision ground ballscrew, both of which are capable of producing 40 N of thrust and reaching linear velocities of 20 mm/s and 30 mm/s respectively.

The leadscrew drive employs a PTFE-coated screw with a preloaded nut to deliver extremely smooth and quiet linear motion. A choice of two leads allows the user to match the desired mix of velocity and

resolution in order to best match the application's requirements.

The ballscrew drive is available in a 1mm lead offering the user 3 µm bi-directional repeatability and 24/7 operation (100% duty cycle).

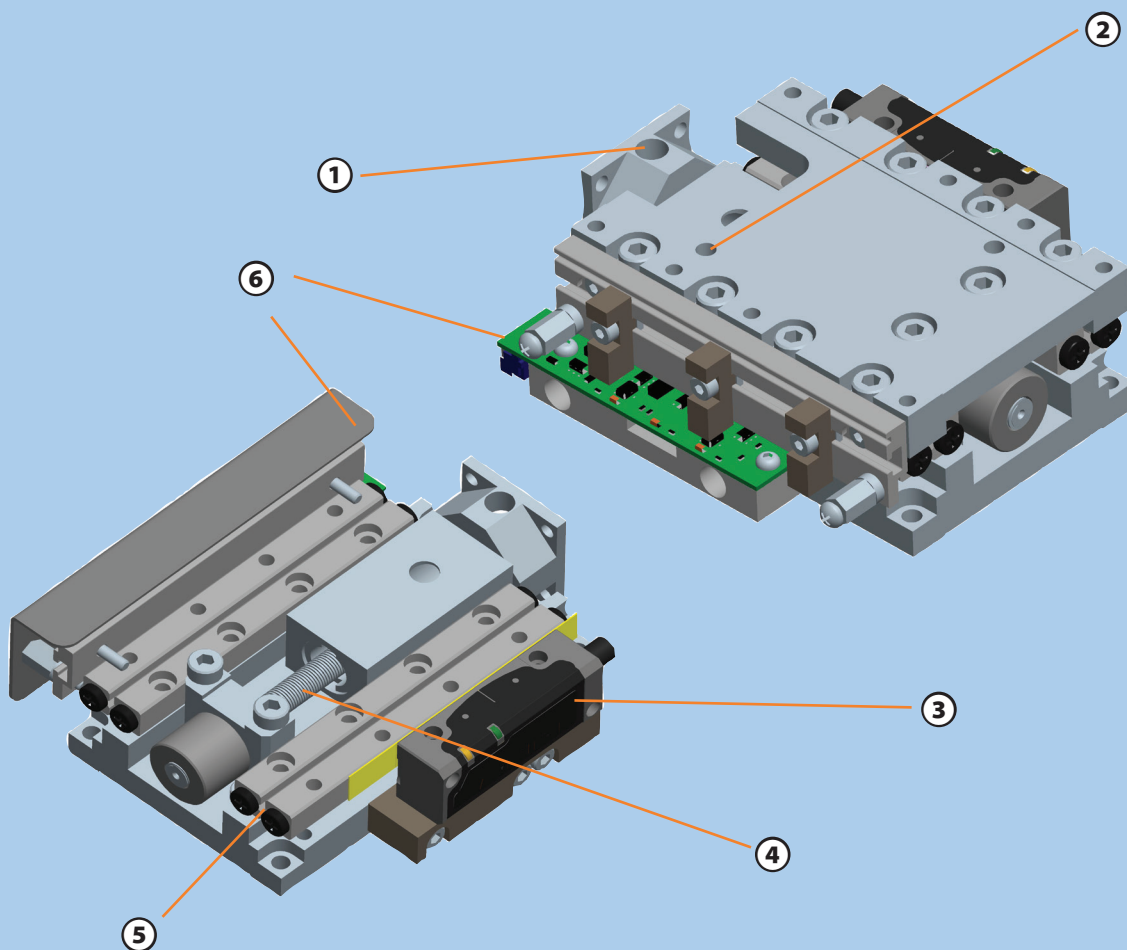
**1 Motor Mount**

NEMA 8 stepper motor mounts directly to stage housing.

2 Dowel Pin Holes

ensure precise repeatable mounting.

3 Optical Linear Encoders

Optional field installed feature is available in three standard resolutions (1.0 μm , 0.1 μm and sine output).

4 Ballscrew or Leadscrew Drive

The 1.0mm lead ballscrew driven stage offers high performance 24/7 operation with a thrust load capacity of 40 N (9 lb) and velocity to 30 mm/s. The leadscrew driven stages are available with 0.5 or 1.0mm leads. The PTFE coated leadscrew provides extremely smooth linear translation at velocities of 20 mm/s.

**5 Crossed Roller Bearings**

provide high stiffness and extremely smooth linear translation. A rack and pinion anti-cage creep design within the bearing races prevents cage creep even at 5 g acceleration, or with cantilevered loads.

6 Home/Limit Sensor Pack

This optional field installable feature consists of three NPN or PNP switches, each of which is fully adjustable over the entire range of travel.

SPECIFICATIONS

The MX45S screw driven positioner is perfect for applications requiring Z-axis focal adjustment, optics alignment, or short indexing of slides. It is the ideal automation solution to replace manual slides and stages.



Performance

	MX45S Leadscrew Drive			MX45S Ballscrew Drive			
		5	15	25	5	15	25
Travel ¹	mm	5	15	25	5	15	25
Normal Load Capacity	kg (lb)	5.0 (11.0)	5.0 (11.0)	7.0 (15.4)	5.0 (11.0)	5.0 (11.0)	7.0 (15.4)
Thrust Load Capacity	N (lb)	40 (9)			40 (9)		
Maximum Velocity ²							
0.5 mm lead	mm/sec	10			—		
1.0 mm lead		20			30		
Acceleration/Deceleration	g	2			2		
Running Torque	mNm (oz-in)	11.0 (1.5)			11.0 (1.5)		
Duty Cycle	%	50			100		
Straightness & Flatness ³	µm	3	5	8	3	5	8
Positional Accuracy ⁴							
With 2000 Count Rotary Encoder	µm	10	18	30	8	12	15
With 1 or 0.1 µm linear Encoder		6	10	12	6	10	12
Bi-directional Repeatability ^{4,5}							
With 2000 Count Rotary Encoder	µm	±8			±3		
With 1 µm Linear Encoder		±4			±2		
With 0.1 µm Linear Encoder		±2			±1		
Input Inertia (without motor)							
0.5 mm lead	10 ⁸ Kg-m ²	2.37	2.76	3.14	—	—	—
1 mm lead		2.58	2.96	3.35	1.41	1.6	1.79
Maximum Screw Speed	rps	20			30		
Screw Efficiency							
0.5 mm lead	%	30			—		
1 mm lead		47			90		
Screw Diameter	mm	4.7			4.0		
Bearing Coefficient of Friction		0.003			0.003		
Unit Mass							
Stage Only		177	200	238	182	205	243
Carriage Only		70	82	100	73	84	104
Additional Mass of Motors & Options	g						
NEMA 8 Stepper ⁶		95			95		
Linear Encoder Option ⁷		16			16		
Limit option Sensor Board ⁷		5			5		
Limit Option Tripper Assembly ⁷		12	13	15	12	13	15

Notes:

¹ Travel is in the direction of the motor mount only

² See speed/force curve for performance with Parker motor.

³ Measured at the carriage center, 35 mm above the mounting surface @ 20° C with no load. Unit bolted to granite surface, flat within 1 µm/300 mm.

⁴ Total accuracy and bi-directional repeatability over full travel (peak to peak) (with 0.5 or 1 mm leadscrew)

⁵ Repeatability valid with NEMA 8 stepper motor and encoder noted.

⁶ Includes rotary encoder (part of base)

⁷ Part of base

MX45S Speed-Force Performance

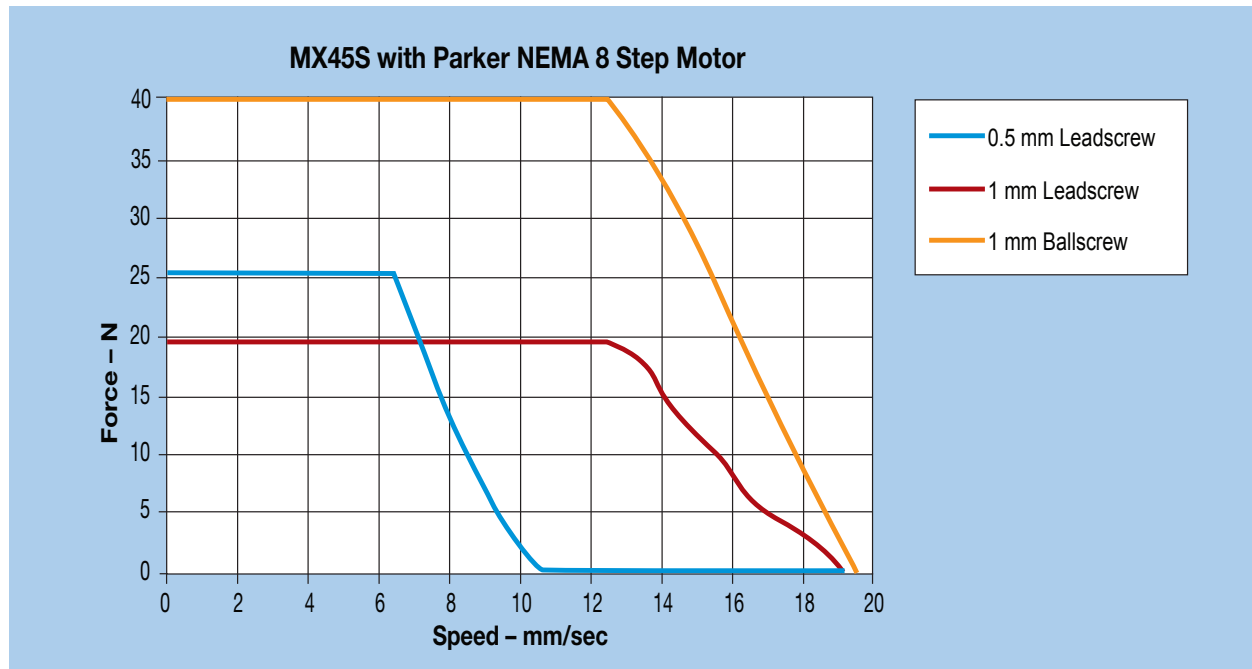

Miniature Positioners

Performance Loading with 2540 km Life Rating

Normal Load Capacity		
5 mm travel		5.0 (11.0)
15 mm travel	kg (lb)	5.0 (11.0)
25 mm travel		7.0 (15.4)
Pitch & Yaw Moment Loading		
25 mm Lever Arm		1.0 (2.2)
50 mm Lever Arm	kg (lb)	0.6 (1.3)
75 mm Lever Arm		0.5 (1.1)
100 mm Lever Arm		0.4 (0.9)
Roll Moment Loading		
25 mm Lever Arm		2.0 (4.4)
50 mm Lever Arm	kg (lb)	1.2 (2.7)
75 mm Lever Arm		0.9 (2.0)
100 mm Lever Arm		0.7 (1.5)

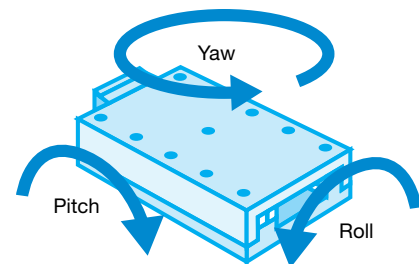

DIMENSIONS

Download 2D & 3D files from
www.parker.com/emn



DIMENSIONS

Dimensions – mm (in)

Note: For T01, T02 and T03, the carriage is shown at end of travel, available stroke towards motor mount only.

T01 – 5 mm Travel

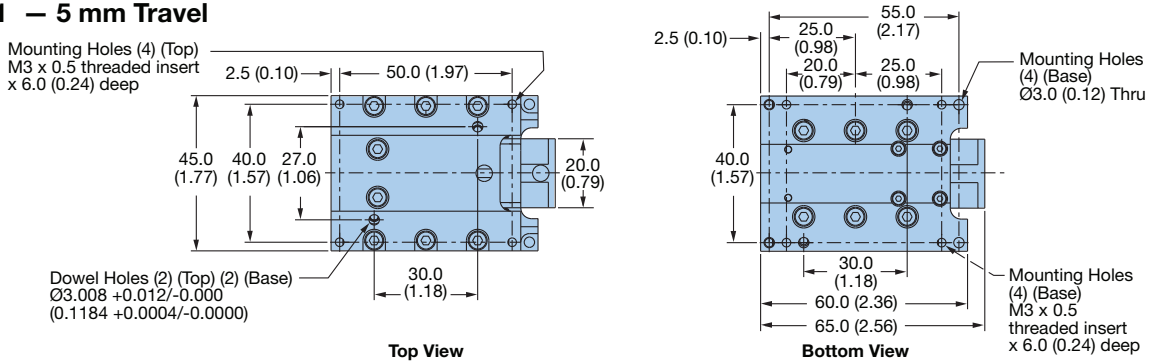

T02 – 15 mm Travel

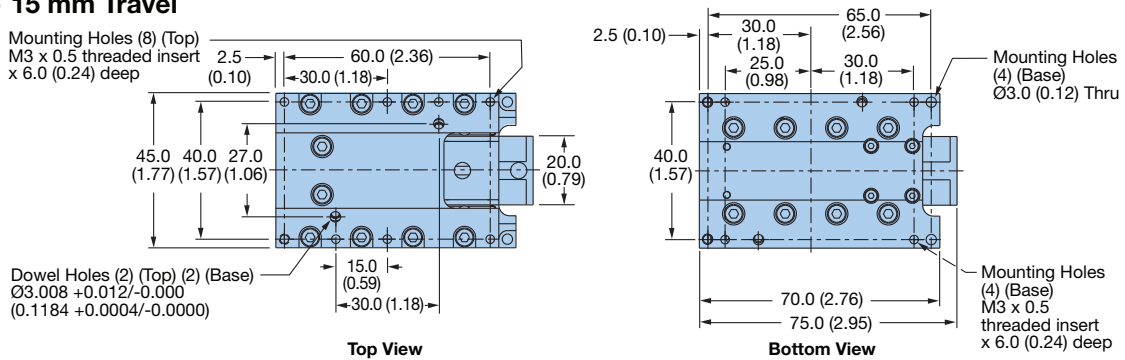

T03 – 25 mm Travel

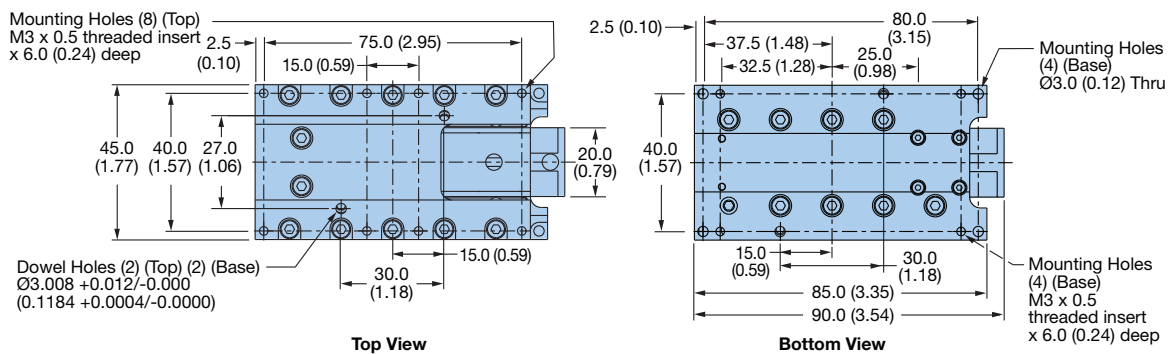

Common Dimensions for T01, T02, T03

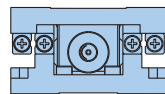

Bearing End View

Motor Pilot $\text{Ø}15.12 +0.06/-0.00$ (0.595 +0.002/-0.000)
 x 1.80 +0.20/-0.00 deep (0.071 +0.007/-0.000)

Motor Mounting (4) Holes $\text{Ø}2.5$ (0.10) Thru Flange

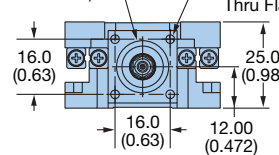

Motor Side End View

MX45S Option Dimensions

Encoder and Limit/Home (T01, T02, T03)

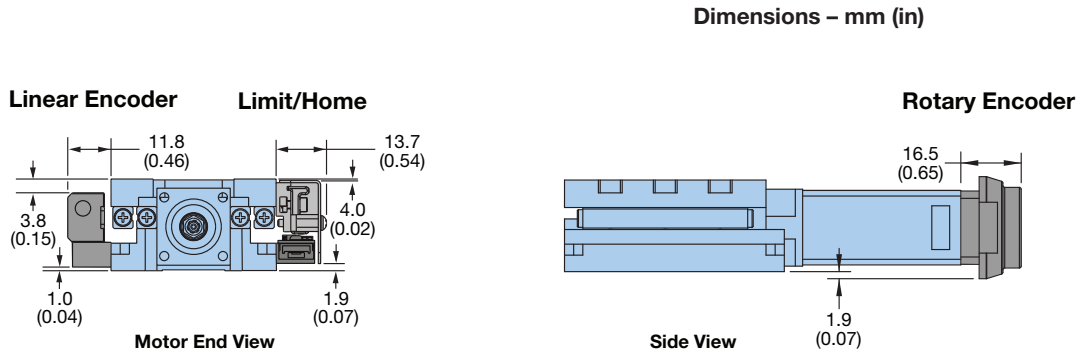

Motor Mounting (T01, T02, T03)

NEMA 8 Motor Mount

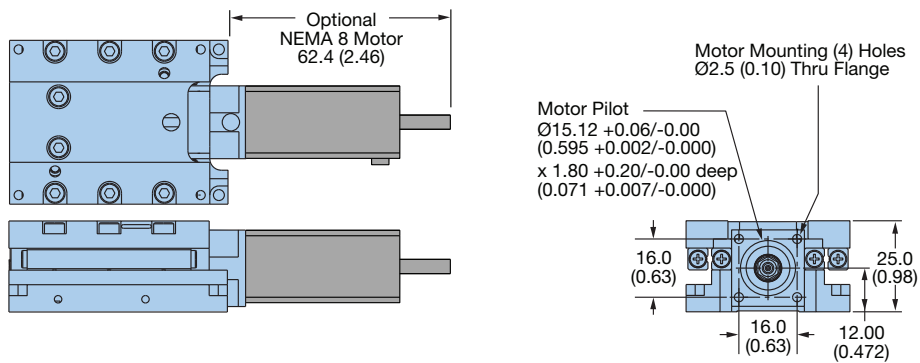

NEMA 11 Motor Mount

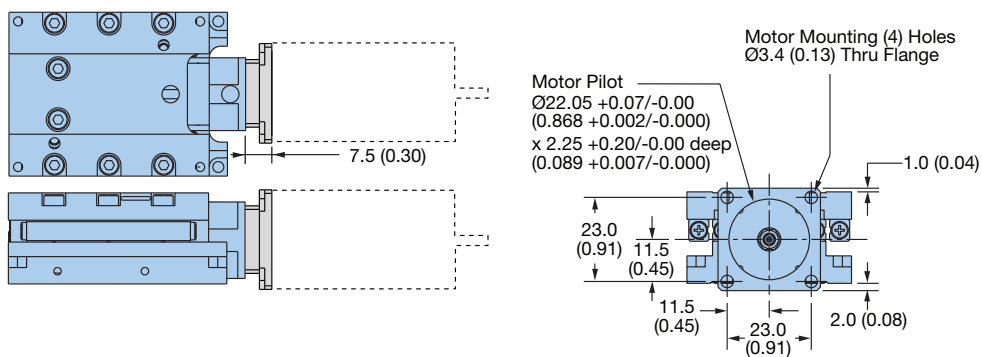

Miniature Positioners

Free sizing and selection support
 from Virtual Engineer at
parker.com/VirtualEngineer



Encoder Options

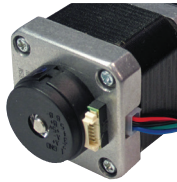

Rotary Encoder

When using stepper motors, positional feedback is readily available with the optional rotary encoder. 400- and 500-line rotary encoders provide position verification and position maintenance. Each encoder comes standard with a 1 meter high-flex cable.

Rotary Encoder Connections

Function	Wire Color
Ground	White
A+	Green
A-	Yellow
+5 VDC	Brown
B+	Blue
B-	Red
Not used	Pink
Not used	Gray

Linear Encoder Digital Outputs

Function	Signal	Interface	
		Pin	
Power	5 V	7.8	
	0 V	2.9	
Incremental	A+	14	
	A-	6	
	B+	13	
	B-	5	
Reference Mark	Z+	12	
	Z-	4	
Limits	P	11	
	Q	10	
Set-Up	X	1	
Alarm	E-	3	
Shield	Inner	—	
	Outer	Case	

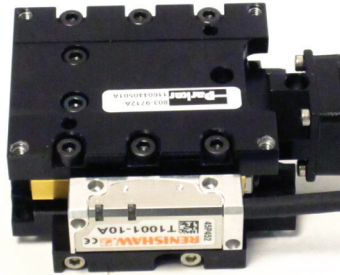

Linear Encoder

A non-contact linear optical encoder provides quadrature output and offers resolutions of 1.0 um, 0.1 um and sine output. On the MX45S, the encoder is mounted externally to the stage body, an addition which can be added later if application requirements change. Each encoder comes standard with a 1 meter high-flex cable.

Rotary Encoder Cable (6-pin differential)

Part Number	Description
006-2398-1.0	1m high-flex with flying leads
006-2398-1.0	1m high-flex with flying leads

Linear Encoder Analog Outputs

Function	Signal	Readhead Interface	
		Color	Pin
Power	5 V	Brown	4, 5
	0 V	White	12, 13
Incremental	Cosine	V ₁₊	9
		V ₁₋	1
	Sine	V ₂₊	10
		V ₂₋	2
Reference Mark	V ₀₊	3	
	V ₀₋	11	
	V _p	7	
Limits	V _q	8	
	Set-Up	V _x	6
Remote CAL	CAL	14	
Shield	Inner	Green/Yellow	—
	Outer	Outer Screen	Case

Stepper Motor



The MX45S is available with a standard 1.8 degree NEMA 8 stepper motor capable of providing 4 oz-in of holding torque. Each motor comes standard with a 1 meter high-flex cable.

Motor Cable Connections

Function	Color
A +	Red
A -	Black
B +	White
B -	Green

Home/Limit Options

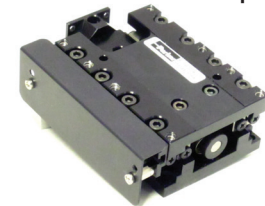

The MX45S features an innovative, compact, fully adjustable and field-installed home/limit sensor pack. The output format is either NPN or PNP and is available as either N.O. or N.C. The sensor pack is powered with +5 to +24 VDC and is capable of sinking or sourcing up to 50 mA per switch.

Limit/Home Cable Connections

Pin Number	Function	Color
1	+ V	Red
2	Ground	Black
3	+ Limit	Orange
4	Home	Green
5	- Limit	Blue

P2™ Microstepping Drive



The P2™ Series stepper drive is an OEM-friendly miniature motion drive capable of up to 2 Amps in a 1" x 1" x 3.3" square package.

- Adjustable run current via potentiometer
- Auto standby adjustable current to reduce heat generation and power consumption
- Stepper resolution to 3200 steps per rev
- RoHS compliant
- DIN rail mountable
- Accepts single or differential step and direction inputs

Visit our website at www.parkermotion.com for complete details on these MX45S system compatible products.

E-DC Microstepping Drive



The DC-input E-DC is a high-performing, low-cost packaged microstepping drive.

- Anti-resonance circuitry suppresses mid-range instability
- Recommended motor inductance range of 0.5 mH to 80 mH
- Selectable resolution up to 50,800 steps/rev
- Auto standby reduces motor current (and heating)
- Current waveforms to optimize smoothness
- Optically isolated step and direction inputs
- Short-circuit and over-temperature protection

Miniature Positioners

Complete your system by integrating one or more of Parker's other miniature linear products.

- MX80 Series 80 mm wide, available in 5 different drive trains
- mSR Series linear motor stage, available in two different linear motor technologies
- LCR Series miniature belt and screw driven actuators

For complete information, visit Parker.com/emdusa

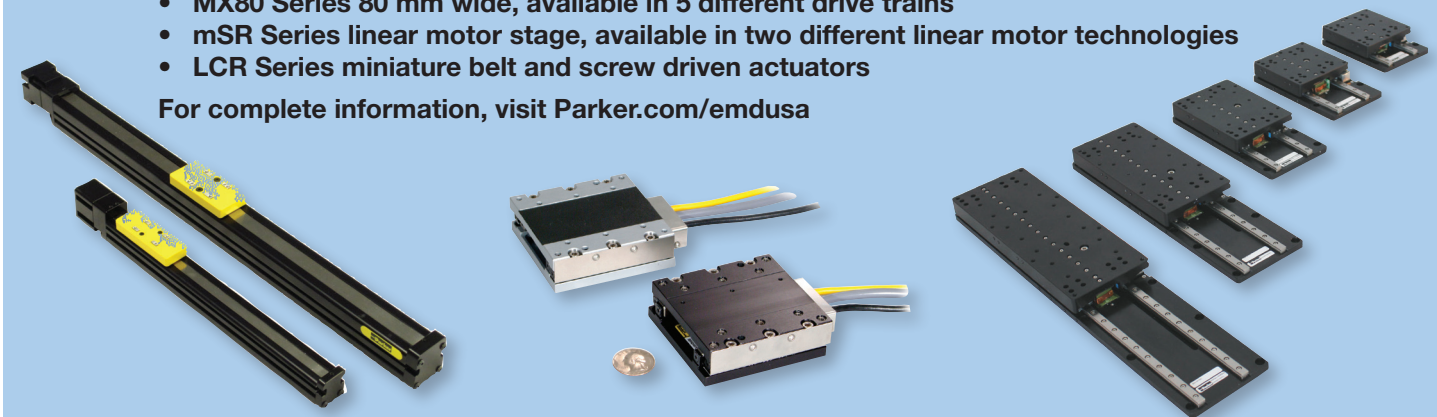

Multi-Axis Bracket Kit Options

MX45S to MX45S Mounting Bracket Kits

To build multi-axis MX45S systems, mounting bracket kits are available to build the two and three-axis configurations shown below with the appropriate order code. Note that only Y-axis travel is a selection criteria; X- and Z-axis travel is not.

Consult factory or visit our website for complete bracket dimensions

Order Codes:

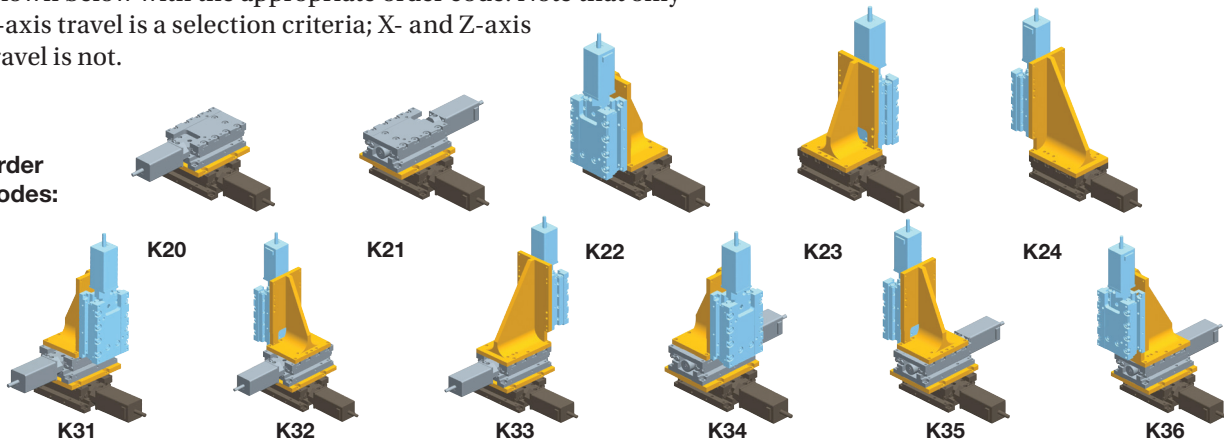

Bracket Kit	Part Number		
	T01*	T02*	T03*
K20	002-2956-200	002-2956-201	002-2956-202
K21	002-2956-200	002-2956-201	002-2956-202
K22	—	002-2956-220	—
K23	—	002-2956-220	—
K24	—	002-2956-240	—
K31	002-2956-310	002-2956-311	002-2956-312
K32	002-2956-310	002-2956-311	002-2956-312
K33	002-2956-330	002-2956-331	002-2956-332
K34	002-2956-310	002-2956-311	002-2956-312
K35	002-2956-310	002-2956-311	002-2956-312
K36	002-2956-330	002-2956-331	002-2956-332

*T01, T02 and T03 designates Y axis travel only

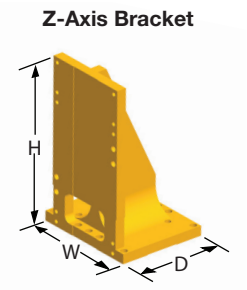

Z-Axis Bracket* – H x W x D (mm)

Bracket Kit	T01, T02, T03
K22, K23	85 x 45 x 55
K24, K33, K36	104 x 45 x 55
K31, K32, K34, K35	85 x 55 x 45

*Not compatible with N11 motor mounts

X-Y Axis Transition Plate Bracket

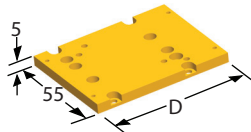

X-Y Axis Bracket – Dimension “D” (mm)

Bracket Kit	T01	T02	T03
K20, K21, K31, K32, K33, K34, K35, K36	60	70	85

MX45S to MX80 Mounting Brackets

MX45S positioners can also be used as a Y- or Z-axis in conjunction with MX80 positioners.

Kit	Configuration	Part Number	H x W x D (mm)
X-Y	MX45ST01 to MX80	002-2958-01	5 x 80 x 80
	MX45ST02 to MX80	002-2958-02	5 x 80 x 80
	MX45ST03 to MX80	002-2958-03	5 x 80 x 92.5
X-Z*	MX45S (all) to MX80	002-2958-04	87.5 x 80 x 80

*Not compatible with N11 motor mounts

