

# Deuterium Tungsten-Halogen Calibration Light Source DH-2000-CAL



## Installation and Operation Manual Document Number 000-10000-030-02-0606

**Offices:** **Ocean Optics, Inc.**  
830 Douglas Ave., Dunedin, FL, USA 34698  
Phone 727.733.2447  
Fax 727.733.3962  
8 a.m.– 8 p.m. (Mon-Thu), 8 a.m.– 6 p.m. (Fri) EST

**Ocean Optics B.V. (Europe)**  
Geograaf 24, 6921 EW DUIVEN, The Netherlands  
Phone 31-(0)26-3190500  
Fax 31-(0)26-3190505

---

**E-mail:** **Info@OceanOptics.com** (General sales inquiries)  
**Info@OceanOpticsBV.com** (European sales inquiries)  
**Orders@OceanOptics.com** (Questions about orders)  
**TechSupport@OceanOptics.com** (Technical support)



**WARNING**

---

Protective Eye Wear Must Be Worn  
When Using This Instrument -  
Intense Ultraviolet Radiation Present  
See Important Safety Notices inside.

---

—A—  
**HALMA  
GROUP  
COMPANY**



Ocean Optics offers the most comprehensive, innovative and high-quality line of modular spectroscopy tools in the world. Mikropack, a leading supplier of spectroscopy and thin film components, is an essential and valuable partner in this enterprise. We have partnered with Mikropack because they are committed to the same goals of innovation and quality that inspire us here at Ocean Optics. As always, Ocean Optics conducts its business in an open, honest and technically available fashion. We invite you to contact us at Ocean Optics, Inc. (see front cover for contact information) or Mikropack GmbH with any technical questions, comments, or applications inquiries. Mikropack GmbH can be contacted at the following location:

MIKROPACK GmbH  
Maybachstraße 11  
D-73760 Ostfildern  
Germany  
Tel.: +49 (0)711 34 16 96-0 • Fax.: +49 (0)711 34 16 96-85  
e-mail: [info@mikropack.de](mailto:info@mikropack.de)  
internet: [www.mikropack.de](http://www.mikropack.de)

**Copyright © 2001-2006 Ocean Optics, Inc.**

All rights reserved. No part of this publication may be reproduced, stored in a retrieval system, or transmitted, by any means, electronic, mechanical, photocopying, recording, or otherwise, without written permission from Ocean Optics, Inc.

This manual is sold as part of an order and subject to the condition that it shall not, by way of trade or otherwise, be lent, re-sold, hired out or otherwise circulated without the prior consent of Ocean Optics, Inc. in any form of binding or cover other than that in which it is published.

**Trademarks**

Microsoft, Windows, Windows 95, Windows 98, Windows Me, Windows NT, Windows 2000, Windows XP and Excel are either registered trademarks or trademarks of Microsoft Corporation.

**Limit of Liability**

Every effort has been made to make this manual as complete and as accurate as possible, but no warranty or fitness is implied. The information provided is on an “as is” basis. Ocean Optics, Inc. shall have neither liability nor responsibility to any person or entity with respect to any loss or damages arising from the information contained in this manual.

---

# Important Safety Notices

1. Do not remove or modify any installed safety device on this equipment. Doing so will void your warranty and create an unsafe operating environment.
2. Dangerous voltages are present in this device. There are NO user serviceable parts inside.
3. Only allow qualified personnel to service this unit.
4. Do not use the unit if it is damaged in any way. Contact your dealer for repair or replacement information.
5. Always screw in the fiber optic cables before starting the instrument.



**WARNING**

Protective eyewear must be worn when using this equipment - Intense ultraviolet radiation present.

**Never look directly into the light beam**, as this can cause eye damage.

---

## Warranty

Mikropack GmbH warrants to the original user of this instrument that it shall be free of any defects resulting from faulty manufacture of this instrument for a period of 12 months from the original date of shipment. There are no warranties for the DH-2000-CAL-B (standard bulb) or DH-2000-CAL-B-DUV (deep ultraviolet bulb).

**This instrument should not be used for any Clinical or Diagnostic purposes.** Data generated in these areas is not warranted in any way by Mikropack GmbH. Any defects covered by this Warranty shall be corrected either by repair or by replacement, as determined by Mikropack GmbH.

There are no warranties that extend beyond the description herein.

This Warranty is in lieu of, and excludes, any and all other warranties or representations expressed, implied, or statutory, including merchantability and fitness, as well as any and all other obligations or liabilities of Mikropack GmbH including, but not limited to, special or consequential damages. No person, firm, or corporation is authorized to assume for Mikropack GmbH. Any additional obligation or liability not expressed provided for herein except in writing duly executed by an officer of Mikropack GmbH:

MIKROPACK GmbH  
Maybachstraße 11  
D-73760 Ostfildern

Tel.: +49 (0)711 3428088 • Fax.: +49 (0)711 3428085  
e-mail: info@mikropack.de



---

# Table of Contents

About This Manual .....	iii
Document Purpose and Intended Audience.....	iii
What's New in this Document .....	iii
Document Summary.....	iii
Product-Related Documentation .....	iii
Upgrades.....	iv
<b>Chapter 1: Setup .....</b>	<b>1</b>
Overview .....	1
Unpacking the DH-2000-CAL .....	2
Contents .....	2
Connecting the Fiber Optic Cable .....	2
<b>Chapter 2: DH-2000-CAL Specifications .....</b>	<b>5</b>
Operating Environment .....	5
DH-2000-CAL Components .....	5
Front Panel .....	6
Rear Panel.....	7
Specifications .....	8
Sample Spectral Output .....	9
Deuterium Output .....	9
Tungsten-Halogen Output .....	10
<b>Chapter 3: Operating Instructions .....</b>	<b>11</b>
Operating the Lamp.....	11
Starting the Lamp .....	11
Turning the Lamp Off.....	11
Warming Up the Lamp.....	11
Configuring Calibration with the DH-2000-CAL .....	12
Configuring the DH-2000-CAL .....	12
Calibrating a Spectrometer with the DH-2000-CAL.....	13

---

<b>Chapter 4: Troubleshooting .....</b>	<b>15</b>
Deuterium Lamp .....	15
Halogen Lamp .....	16
<b>Appendix A: Maintenance .....</b>	<b>17</b>
Overview .....	17
Recalibration.....	17
Bulb Replacement .....	17
Replacing the Deuterium Bulb.....	18
Replacing the Halogen Bulb .....	19
<b>Index.....</b>	<b>21</b>

---

# About This Manual

## Document Purpose and Intended Audience

This document provides you with an installation section to get your system up and running.

## What's New in this Document

This version of the *Deuterium Tungsten-Halogen Calibration Light Source DH-2000-CAL Installation and Operation Manual* clarifies the calibration range.

## Document Summary

Chapter	Description
Chapter 1: <a href="#">Setup</a>	Contains a list of package contents and unpacking instructions.
Chapter 2: <a href="#">DH-2000-CAL Specifications</a>	Contains operating environment specifications, as well as other physical details of the product.
Chapter 3: <a href="#">Operating Instructions</a>	Provides instructions for operating the DH-2000-CAL Light Source.
Chapter 4: <a href="#">Troubleshooting</a>	Contains troubleshooting information for the power supply and both the deuterium and halogen lamps.
Appendix A: <a href="#">Maintenance</a>	Provides instructions for changing the bulb.

## Product-Related Documentation

You can access documentation for Ocean Optics products by visiting our website at <http://www.oceanoptics.com>. Select *Technical* → *Operating Instructions*, then choose the appropriate document from the available drop-down lists. Or, use the **Search by Model Number** field at the bottom of the web page.

You can also access operating instructions for Ocean Optics products on the *Software and Technical Resources* CD included with the system.

Engineering-level documentation is located on our website at *Technical* → *Engineering Docs*.

# Upgrades

Occasionally, you may find that you need Ocean Optics to make a change or an upgrade to your system. To facilitate these changes, you must first contact Customer Support and obtain a Return Merchandise Authorization (RMA) number. Please contact an Ocean Optics Application Scientist for specific instructions when returning a product.



---

# Chapter 1

# Setup

## Overview

The following sections provide instructions on unpacking and setting up your DH-2000-CAL Calibration Light Source.

Before using the DH-2000-CAL for the first time check for transport damage. Be sure to adhere to all warnings on the unit and in this manual.



# Unpacking the DH-2000-CAL

## ► Procedure

1. Unpack your lamp assembly and power supply carefully. Although the lamp is rigidly mounted, dropping this instrument can cause permanent damage.
2. Inspect the outside of the instrument and make sure that there is no damage. Do not use the instrument if damage is present.
3. Use this instrument in a clean laboratory environment (see [Operating Environment](#)).

## Contents

Your DH-2000-CAL package should contain the following:

- ❑ DH-2000-CAL unit
- ❑ Power cord
- ❑ UV safety goggles
- ❑ CC-3 Cosine Corrector
- ❑ Barrel adapter for SMA 905 Connectors (fibers)
- ❑ Calibration diskette
- ❑ Four lamp calibration files:
  - Deuterium lamp with bare fiber
  - Deuterium lamp with CC-3 Cosine Corrector
  - Tungsten Halogen lamp with bare fiber
  - Tungsten Halogen lamp with CC-3 Cosine Corrector
- ❑ Four calibration reports (one for each calibration file type)

## Connecting the Fiber Optic Cable

Use the following procedure to connect the cable to the lamp. See the [Sample Spectral Output](#) section for specific information on configuring your optical fiber or cosine corrector.

► **Procedure**

To connect the fiber optic cable to the DH-2000-CAL,



1. Locate the cap on the front of the DH-2000-CAL.
2. Lift the cap on the front of the DH-2000-CAL to expose the optical input.
3. Insert the SMA connector barrel or CC-3-UV **fully** into the optical input.
4. Secure with the setscrew on the optical input.



---

## Chapter 2

# DH-2000-CAL Specifications

This section provides information on the operating environment, physical controls, and dimensions of the DH-2000-CAL. It also provides a graph of spectral lines.

## Operating Environment

The following table provides information on optimizing the operating environment of your DH-2000-CAL.

Operating Environment	The DH-2000-CAL Unit . . .
Moisture	Is designed for operation in dry rooms only.
Ventilation	Should be situated so that its location or position does not interfere with proper ventilation.
Heat	Should be situated away from any device that emits excessive heat.
Object and Liquid Entry	Should be positioned so that objects do not fall on top of the unit. Additionally, ensure that no liquids are spilled into the enclosure through openings.
Power Sources	Should be connected to a power supply with the following specifications: <ul style="list-style-type: none"><li>• Units manufactured since April 2003 are equipped with power supplies that can handle voltage input of 90 to 240 VAC.</li><li>• Units manufactured before April 2003 are equipped with power supplies that can handle either 110 VAC or 240 VAC. These units have serial numbers formatted as 02000XXX.</li></ul> The power type should be listed on a sticker on the rear of the light source.

## DH-2000-CAL Components

The following sections describe the components located on the front and rear of the DH-2000-CAL unit.

# Front Panel

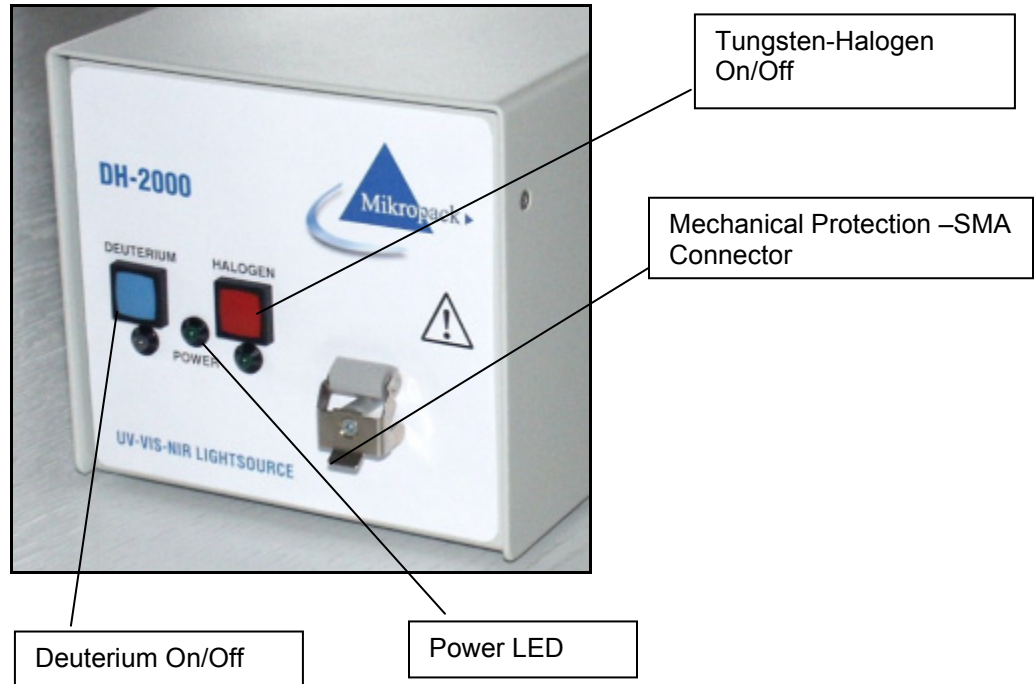

Component	Description
Deuterium On/Off	Press to turn the Deuterium lamp on or off. There is a delay of 20 seconds before the Deuterium Tungsten-Halogen lamp is illuminated. You must allow the bulb to warm up for 20 minutes to receive accurate data from the lamp. LED lights green upon successful illumination, or red to indicate lamp malfunction.
Power LED	Indicates the power state of the DH-2000-CAL.
Mechanical Protection – Optical Output	Covered to protect users from unintentionally looking directly at the beam of light. Connect the fiber cable to the DH-2000-CAL <b>BEFORE</b> turning the lamp on to avoid unnecessary exposure to UV radiation. Always wear proper eye protection when using the DH-2000-CAL lamp.
Halogen On/Off	Press to turn the Halogen lamp on or off. Requires a warm-up time of 20 seconds before the Halogen lamp is illuminated. LED lights green upon successful illumination, or red to indicate lamp malfunction.

## Rear Panel

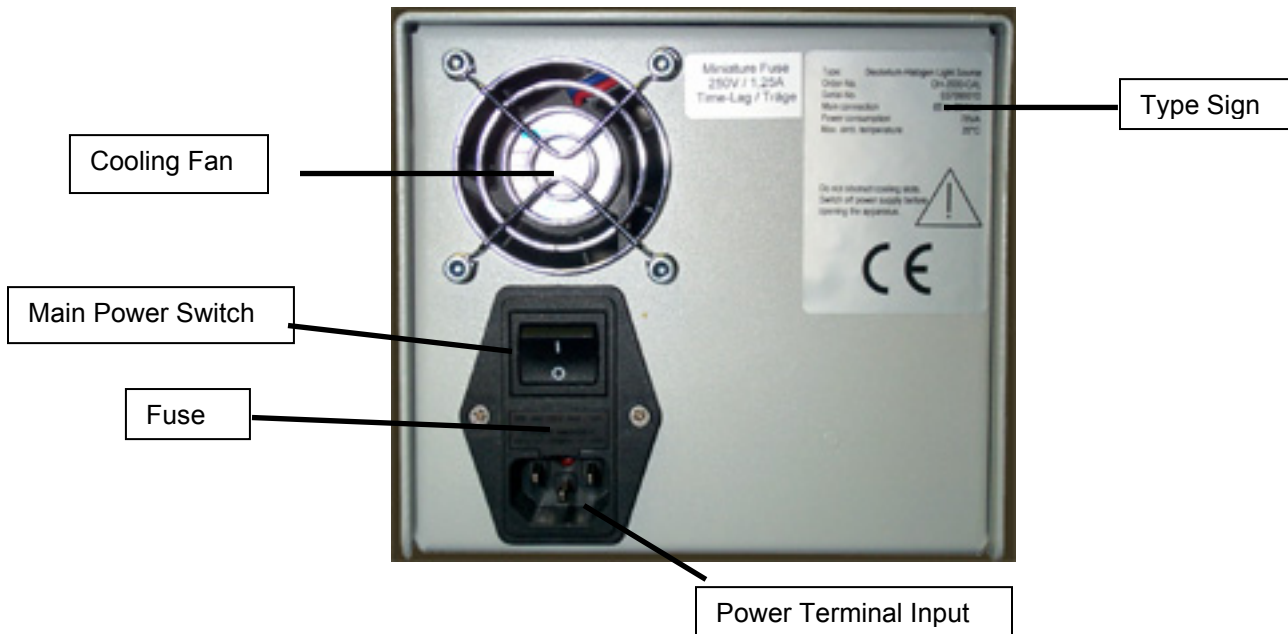

Component	Description
Power Terminal Input	Connect power cable to provide voltage to DH-2000-CAL: <b>Note:</b> Only connect the power cable to the lamp when the Main Power Switch is in the OFF position.
Main Power Switch	Turn on to supply power to the DH-2000-CAL. The Power LED illuminates when this switch is in the On position.
Fuse	Contains the fuse to protect the unit against overload: European Fuse Type: Miniature fuse 5 x 20 mm, 1 Amp slow blow USA Fuse Type: Miniature fuse 5 x 20 mm, 2.5 Amp slow blow
Cooling Fan	Cools the interior of the DH-2000-CAL. Do not obstruct.
Type Sign	Information about: <ul style="list-style-type: none"> <li>– Type</li> <li>– Order No.</li> <li>– Main connection</li> <li>– Warnings</li> <li>– Version</li> <li>– Serial No.</li> <li>– Max. Ambient. Temperature</li> <li>– CE-Marking</li> </ul>

# Specifications

Specifications	Deuterium Lamp Criteria	Tungsten-Halogen Lamp Criteria
Wavelength Range	220–400 nm	300–1050 nm
Current – Voltage – Stability	≤0,01 % / h	0.4% of voltage
Current – Voltage – Drift	≤0,01 % / h	
Warm-Up Time	20 minutes	
Lamp Voltage	Ignition 580V / 20°	12V DC / 1.67A
Lamp Current	Operating 85 V / 0.3A	
Lamp Lifetime	1000 hours	
Radiation Characteristics	Aperture 0.5mm NA26° (13°)	Focused
Performance Guaranteed Temperature	5°C – 35°C	
Humidity	5 - 95% without condensation at 40°	
Internal Power Consumption	25 W	20 W
Total Power Max. Power Consumption	100 Watt/190 Watt (Heating D-Lamp for 20sec)	
Power Requirements: European Version (prior to 4/2003) USA Version (prior to 4/2003) All units manufactured after 4/2003	230-240V 50/60 Hz 110-115V 50/60 Hz 90-240V 50/60 Hz See <a href="#">Operating Environment</a> for specific information.	
Markings / Directives	CE; VDI/VDE 0160; EN 61010	
Weight	6 kg	
Size	150 x 135 x 319 mm	



# Sample Spectral Output

The following charts illustrate the spectral output of the DH-2000-CAL.

## Deuterium Output

**DH-2000-CAL UV Calibration Using Bare Optical Fiber**

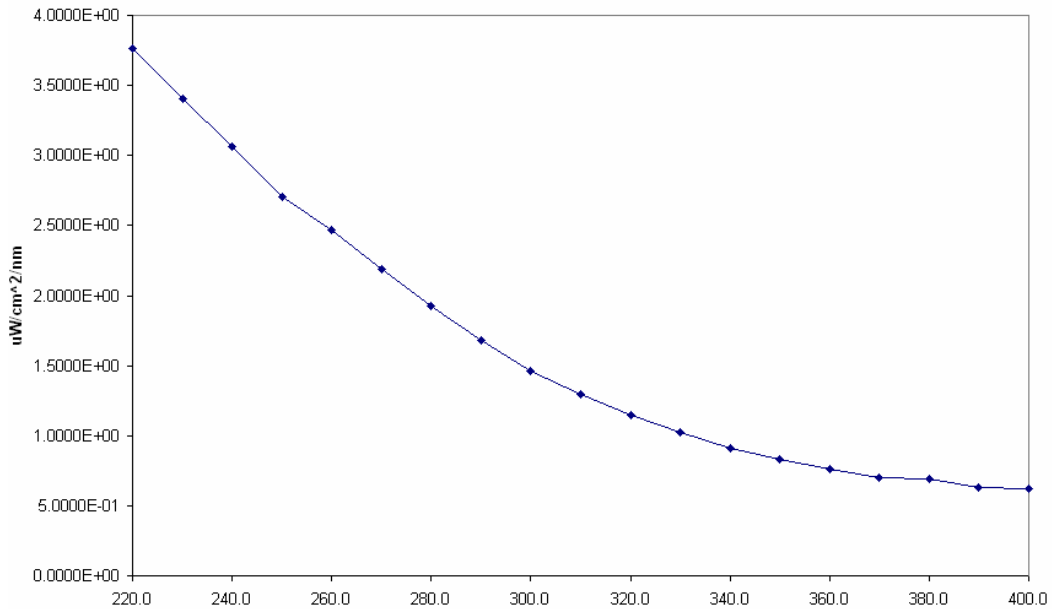

**Deuterium bulb spectral output using a bare SMA-terminated fiber**

**DH-2000-CAL UV Calibration Using Cosine-corrected Irradiance Probe**

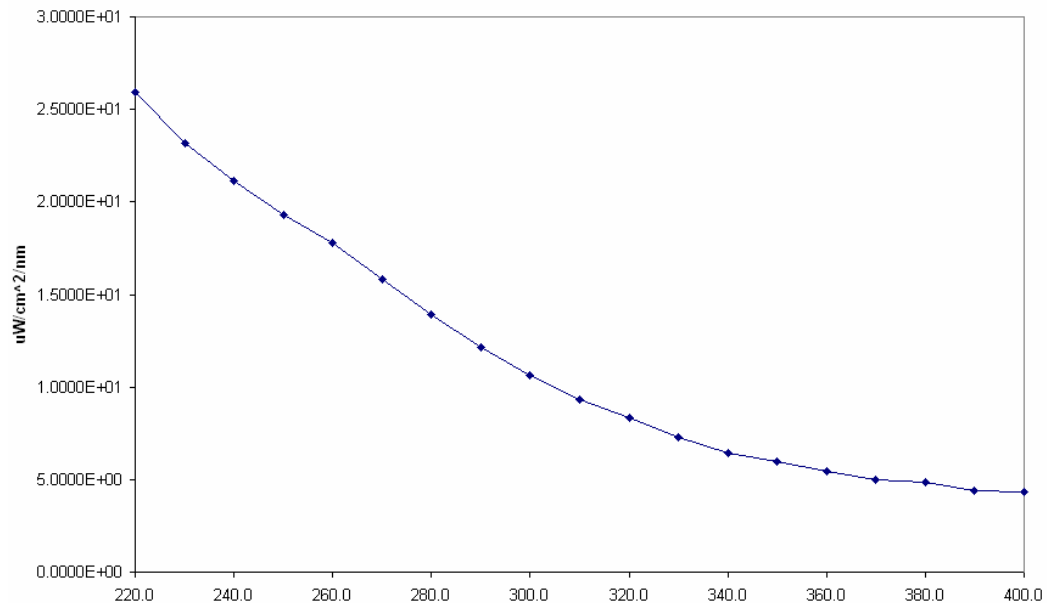

**Deuterium bulb spectral output using a CC-3 Cosine Corrector**

# Tungsten-Halogen Output

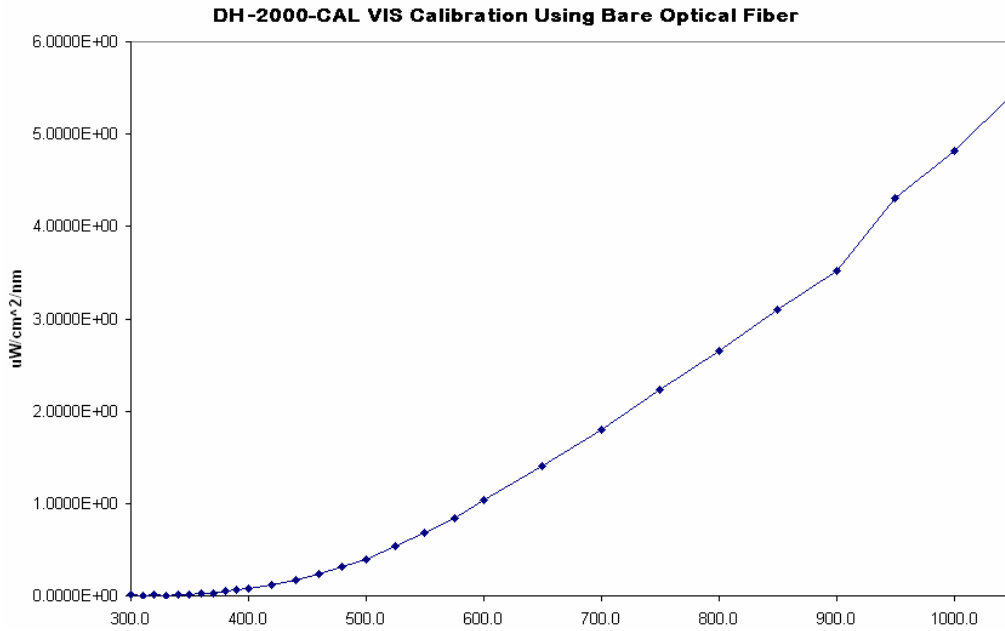

## Tungsten-Halogen bulb spectral output using a bare SMA-terminated fiber

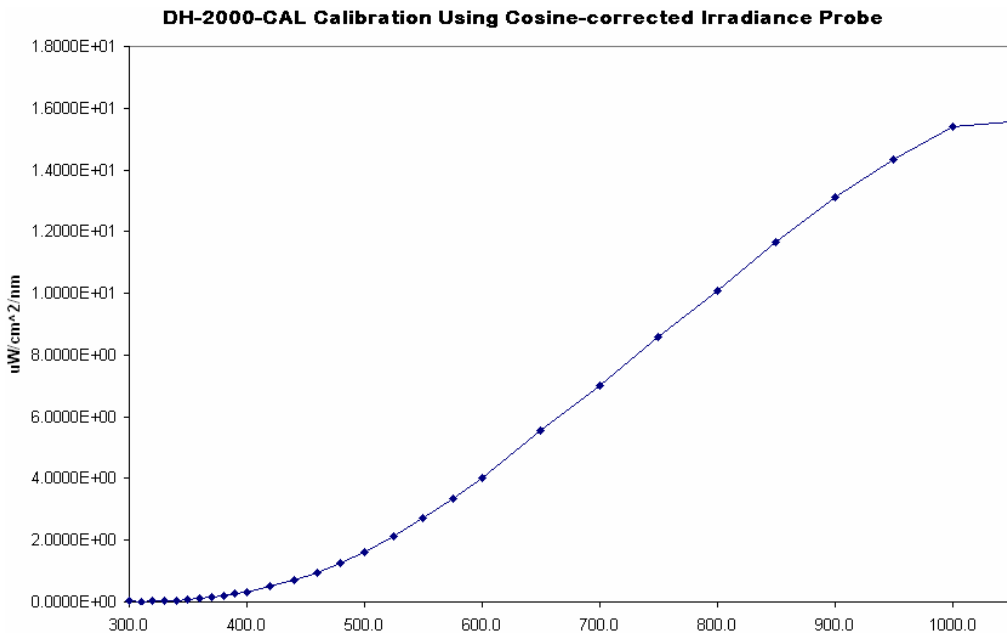

## Tungsten-Halogen bulb spectral output using a CC-3 Cosine Corrector

# Operating Instructions

## Operating the Lamp

The following sections provide instructions on operating the Deuterium and Tungsten-Halogen lamps in the DH-2000-CAL.

### Starting the Lamp

Press the Deuterium or Halogen On/Off switch down to preheat the desired lamp. The bulb requires a 20 second preheating period. You must allow this warm up period in order to receive accurate data. After the warm up period, the lamp will illuminate.

After successful illumination, the two-color LED beneath the lamp's On/Off switch lights up green to indicate that the lamp is on. Should the lamp fail to light, see [Troubleshooting](#) for more information.



**WARNING**

Protective eyewear must be worn when using this equipment - Intense ultraviolet radiation present.

**Never look directly into the light beam**, as this can cause eye damage.

---

### Turning the Lamp Off

Turn the lamp off by pressing the appropriate On/Off switch.

### Warming Up the Lamp

The Deuterium and Tungsten-Halogen lamps require 20 minutes of operation to reach a state of thermal equilibrium. During this warm-up period, the intensity of the UV output power can vary substantially.

If applications require extreme intensity stability, the Halogen lamp should be warmed up for an additional 15 minutes. Once warmed up for this amount of time, the lamp will reach specified drift values.

# Configuring Calibration with the DH-2000-CAL

The following sections provide instructions on configuring calibration with the DH-2000-CAL.

## Configuring the DH-2000-CAL

### ► Procedure

Follow the steps below to configure the DH-2000-CAL:

1. If using a bare fiber with the DH-2000-CAL:
  - a. Screw the fiber end onto the SMA barrel adapter until secure.
  - b. Insert the SMA barrel adapter completely into the optical input on the DH-2000-CAL.
- If using a CC-3 cosine corrector with the DH-2000-CAL:
  - a. Screw the CC-3 cosine corrector onto one end of the fiber until the connection is tight.
  - b. Insert the CC-3 cosine corrector completely into the input on the DH-2000-CAL.
2. Use the Allen wrench to tighten the setscrew on the optical input of the DH-2000-CAL.
3. Screw the other end of the fiber into the SMA 905 Connector of the spectrometer.
4. Plug the black power cord into the back of the DH-2000-CAL.
5. Plug the other end of the power cord into a standard outlet.
6. Turn the lamp power on using the black switch on the rear of the DH-2000-CAL.
7. Switch the individual lamps on using the buttons on the front of the DH-2000-CAL.
8. Allow the lamp to warm up for at least 20 minutes before proceeding.

# Calibrating a Spectrometer with the DH-2000-CAL

## ► Procedure

Follow the instructions below to calibrate a spectrometer using the DH-2000-CAL:

1. Copy all calibration files supplied with the lamp to the application (software you will be using) folder.
2. Follow the instructions in your software for UV range calibration, using the appropriate Deuterium lamp file (bare fiber or CC-3 Cosine Corrector).
3. Follow the instructions in your software for VIS range calibration, using the appropriate Tungsten Halogen lamp file (bare fiber or CC-3 Cosine Corrector).

---

### Note

You can use either UV or VIS range calibration only. Note that if the spectrometer range exceeds the calibration range, the data obtained outside the calibration range is inaccurate and should be discarded. Deuterium calibration is not appropriate for the VIS range, and Tungsten Halogen calibration is not appropriate for the UV range.

If a full range calibration is required, combine the two resulting calibration files (UV and VIS) at 400 nm either manually or in your software.

---



## Troubleshooting

### Deuterium Lamp

If the power supply or Deuterium lamp does not seem to be functioning properly, check the following:

Issue	Probable Cause	Resolution
Power switches on, but no LEDs light.	Line power not present	Check line voltage
	Fuse defective	Check fuse
Deuterium lamp does not ignite. The two-color LED under the Deuterium On/Off switch lights up red, indicating an error.	Deuterium lamp too hot	Allow the Deuterium lamp to cool down (20 minutes). Press On/Off switch again to reset the Deuterium Tungsten-Halogen lamp, then press again to restart.
	Deuterium lamp life exhausted	Replace Deuterium lamp
	Deuterium lamp's internal connection plug is not closed right	Open unit (see the <a href="#">Maintenance</a> ) and close connector plug.
Deuterium lamp turns off during operation.	Deuterium lamp too hot	Turn off the unit. Allow the unit to cool down for at least 20 minutes. Once the unit has cooled down, turn the Deuterium lamp back on.

# Halogen Lamp

If the Halogen lamp does not seem to functioning properly, check the following:

Issue	Probable Cause	Resolution
Halogen lamp does not work after pressing On/Off switch	Deuterium lamp is warming up	Wait until the Deuterium lamp has lit and try again
	Halogen lamp is defective	Replace the Halogen lamp
LED does not light after switching on the Halogen lamp	Internal power supply is defective	Disconnect the unit from the main power source and contact your dealer for repair or replacement



---

# Appendix A

# Maintenance

## Overview

Maintenance of your DH-2000-CAL unit involves periodic recalibration and replacing the light source bulbs, when necessary.

## Recalibration

You should have the DH-2000-CAL recalibrated after every 50 hours of use. Contact Ocean Optics or your DH-2000-CAL vendor for recalibration information. The recalibration order code is DH-2000-RECAL.

## Bulb Replacement

You can manually change the Deuterium and Halogen bulbs in the DH-2000-CAL. However, as a recalibration is required when the bulb in the DH-2000-CAL is replaced, we recommend sending the DH-2000-CAL in for bulb replacement and calibration service after 50 hours of use.

Contact an Ocean Optics Application Sales Engineer for information on bulb replacement service and lamp recalibration.

To order replacement bulbs for the DH-2000-CAL, order the following item number(s):

- Deuterium Spare Bulb (220 – 400 nm): D-2000-B
- Deuterium Spare Bulb Deep UV (190 – 400 nm): D-2000-B-DUV
- Halogen Spare Bulb (300 – 1050 nm): DH-2000-B

## Replacing the Deuterium Bulb

---

### Note

You MUST recalibrate the lamp after replacing the bulb. See [Recalibration](#) for more information.

---

### ► Procedure

1. Open the six slotted screws (14) and open the casing cover.

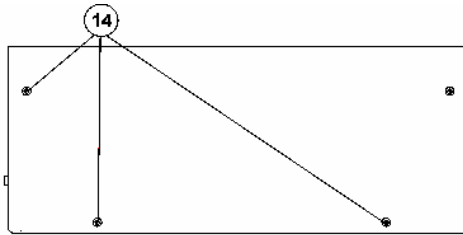

2. Open the screws (15) with the tool (18) that is delivered with the spare bulb (16).
3. Disconnect the old bulb and connect the new Deuterium Tungsten-Halogen lamp only with the originally supplied connection plugs (17).

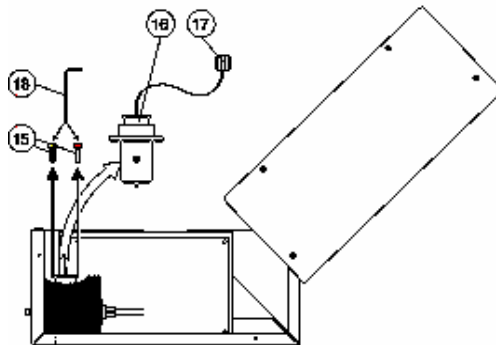

## Replacing the Halogen Bulb

---

### Note

You MUST recalibrate the lamp after replacing the bulb. See [Recalibration](#) for more information.

---

1. Open the six slotted screws (14) and open the casing cover.

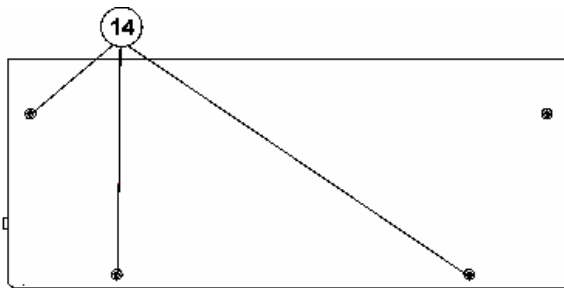

2. Remove the screw (21) with the tool (20) provided with the spare bulb (19).
3. Disconnect the old Halogen bulb from the connection plugs (18)
4. Open the screws of the cable-clamp on the lamp-side and remove the defective Halogen lamp module.
5. Insert the new Halogen lamp module and Replace the screw (21).
6. Reattach the two cables of the Halogen lamp module to the cable-clamp.

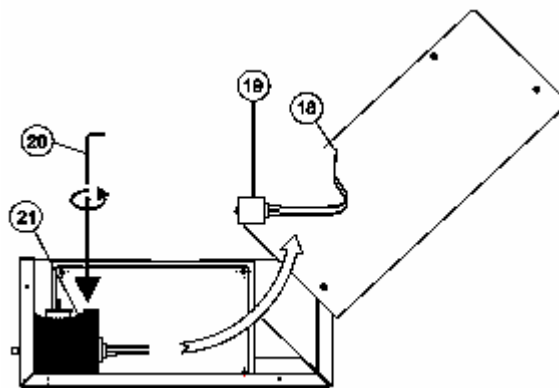



---

# Index

## B

bulb replacement, 17  
deuterium bulb, 18  
halogen bulb, 19

## C

calibrating a spectrometer, 13  
components, 5  
  front panel, 6  
  rear panel, 7  
configuring, 12  
connecting fiber optic cable, 2

## D

document  
  audience, iii  
  purpose, iii  
  summary, iii

## L

lamp  
  starting, 11  
  turning off, 11  
  warming up, 11

## M

maintenance, 17

## O

operating environment, 5  
operating instructions, 11  
  lamp, 11

## P

package contents, 2  
product-related documentation, iii

## R

recalibration, 17

## S

setup, 1  
specifications, 5  
  specifications table, 8  
spectral output, 9  
  Deuterium, 9  
  Tungsten-Halogen, 10

## T

troubleshooting  
  deuterium lamp, 15  
  halogen lamp, 16  
troubleshooting table, 15

## U

unpacking procedure, 2  
upgrades, iv

## W

warranty, A  
what's new, iii

