

# ***Solo PIV***

## ***Nd:YAG Laser System***

### ***Operator's Manual***



January 2005  
Part No. 90-1020E

## Preface

This manual contains information for proper installation and operation of the Solo PIV and accessories. The Solo PIV laser systems comply with the Center for Device and Radiological Health (CDRH) Standard 21 CFR 1040.



**The Solo PIV laser systems are Class 4 lasers and emit laser radiation that can be harmful to your eyes and skin. It is essential that the safety section of this manual is read before installing this laser and that the user follows the instructions given for safe laser operation.**

Do not attempt to repair the laser while it is under warranty. Report all problems to New Wave Research, Inc. for warranty repair.

New Wave Research, Inc. can be reached at:  
48660 Kato Road  
Fremont CA 94538  
Tel: 510-249-1550  
Tel: 800-566-1743  
FAX: 510-249-1551  
E-mail: [customer-service@new-wave.com](mailto:customer-service@new-wave.com)  
Web: <http://www.new-wave.com>

© Copyright 2002, 2003, 2004, 2005 by New Wave Research, Inc. All rights reserved. Printed in the U.S.A. Reproduction or translation of any part of this publication, except as permitted by the 1976 United States Copyright Act, without prior written permission of New Wave Research, Inc. is unlawful.

# Table of Contents

## Chapter One – Laser Safety

- 3 ..... Introduction
- 3 ..... Optical Safety
- 4 ..... Laser Safety
- 4 ..... Electrical Safety
- 5 ..... Safety Features
  - 5..... Laser Covers
  - 5..... Interlocks
  - 5..... Exit Shutter
- 5 ..... Regulatory Compliance
  - 6..... Laser Classification
  - 6..... CE Declaration of Conformity
  - 7..... Location of Safety Labels

## Chapter Two – Description and Specifications

- 11 .... Introduction
- 11 .... Optical Layout
  - 12..... Optical Attenuator
  - 12..... Second Harmonic Generation
  - 12..... Third Harmonic Generation (Solo 120)
  - 12..... Fourth Harmonic Generation
- 12 .... External Control
- 13 .... Safety Interlocks
- 13 .... Power Supply
  - 13..... AC Power
  - 13..... Water Cooling System
- 14 .... Solo Specifications

## Chapter Three – Installation

- 17 .... Voltage Requirements
- 17 .... Power Line Fuse
- 17 .... Laser Umbilical
- 18 .... Control Panel
- 18 .... Interlock Connector
- 18 .... Cooling System

## Chapter Four – Operation

- 21 ..... Starting the Laser
- 22..... Turning the Laser Off
- 22..... Controls and Indicators
  - 22..... Power Supply
  - 23..... Control Panel
- 23..... Interlocks
  - 23..... Internal Interlocks
  - 23..... External Interlock
- 23..... Triggering and Timing
  - 24..... Inputs and Outputs
  - 25..... Internal Triggering
  - 25..... External Triggering
  - 26..... External Q-switch Triggering
  - 27..... External Flashlamp Triggering
  - 27..... External TTL Direct Triggering
- 27..... Harmonic Generators
  - 28..... Second Harmonic Generator
- 29..... Solo PIV Alignment

## Chapter Five – Maintenance, Service, and Troubleshooting

- 33..... Maintenance and Service
- 33..... Recommended Scheduled Maintenance
- 33..... Cooling System
  - 34..... De-ionization Cartridge Replacement
- 35..... Flashlamp Replacement
- 38..... Troubleshooting
- 38..... Observed Conditions
- 39..... Recommended Procedures
  - 39..... Procedure 1. Laser does not start
  - 39..... Procedure 2. Laser starts, but no light is emitted
  - 39..... Procedure 3. Low fundamental output energy
  - 40..... Procedure 4. Unstable laser energy
  - 40..... Procedure 5. Clipped laser beam
  - 40..... Procedure 6. Low second harmonic energy

# Figures and Tables

## List of Figures

- 7 ..... Figure 1-1: Location of Labels
- 8 ..... Figure 1-2: Power Supply Identification Label & Certification
- 8 ..... Figure 1-3: Laser Head Identification Label
- 8 ..... Figure 1-4: Solo I, II, III, IV Warning Label
- 8 ..... Figure 1-5: Solo 120 Warning Label
- 8 ..... Figure 1-6: Warning Label, International for Solo I, II, III, IV
- 8 ..... Figure 1-7: Warning Label, International for Solo 120
- 8 ..... Figure 1-8: Aperture Label
- 8 ..... Figure 1-9: Defeatable Interlock Label
- 11 .... Figure 2-1: Layout of Solo Head with Options
- 17 .... Figure 3-1: Power Supply Back Panel
- 21 .... Figure 4-1: Control Panel Layout
- 24 .... Figure 4-2: Power Supply BNC input/output Connections
- 25 .... Figure 4-3: Timing Diagram for Internal Triggering
- 26 .... Figure 4-4: Timing Diagram for External Triggering
- 28 .... Figure 4-5: Half Wave Plate Adjustment
- 28 .... Figure 4-6: Second harmonic Angle Adjustment
- 29 .... Figure 4-7: Solo PIV Beam Overlap Adjustment
- 34 .... Figure 5-1: Cooling System in the Power Supply
- 35 .... Figure 5-2: Removing Leads to Replace Flashlamp for Solo I, II, III
- 35 .... Figure 5-3: Removing Leads to Replace Flashlamp for Solo 120 and IV
- 36 .... Figure 5-4: Pump Chamber Attachment Screws for Solo I, II, III
- 36 .... Figure 5-5: Pump Chamber Attachment Screws for Solo 120 and IV
- 37 .... Figure 5-6: Removal of Pump Chamber Assembly End Cap for Solo I, II, III
- 37 .... Figure 5-7: Figure 5-7. Removal of Pump Chamber Assembly End Cap for Solo 120 and IV
- 37 .... Figure 5-8: Pump Chamber Water Seal O-rings for Solo I, II, III
- 38 .... Figure 5-9: Pump Chamber Water Seal O-Rings for Solo 120 and IV

## List of Tables

- 14..... Table 2-1: Solo Performance Specifications
- 27..... Table 4-1: TTL Direct Port
- 38..... Table 6-1: Observed Conditions

Chapter One

# Laser Safety



## Introduction

The New Wave Research Solo Nd:YAG laser is a high performance laser that requires care in handling. As with any high power laser system, it is important that every person who works with the laser is trained in the safe operation. It is also important that each person who works in the area is aware of necessary procedures to safely turn the laser off.

The Solo-PIV laser system is designed for Particle Image Velocimetry (PIV). The Solo-PIV consists of two IR laser heads combined in a single package with a second harmonic generator and one discrete power supply.

## Optical Safety

The Solo Nd:YAG laser generates high-energy infrared radiation that can pose serious risks to eye safety. Infrared radiation is invisible to the eye, so the hazard is not immediately obvious, but the radiation can be focused onto the retina. For this reason it is very important to always wear safety glasses and to be aware of any possible reflections.



**WARNING: The New Wave Research Solo Nd:YAG laser is a Class 4 high power laser whose beam is, by definition, a safety and fire hazard. Take all necessary precautions to prevent accidental exposure to both direct and reflected beams. DIFFUSE AS WELL AS SPECULAR BEAM REFLECTIONS CAN CAUSE SEVERE EYE AND SKIN DAMAGE.**



**WARNING: BECAUSE THE 1064nm OUTPUT BEAMS OF AN ND:YAG LASER ARE INVISIBLE THEY ARE EXTREMELY DANGEROUS. Infrared radiation passes easily through the cornea, which focuses it onto the retina in the eye, where it can cause instantaneous permanent damage including blindness. AVOID EYE AND SKIN EXPOSURE TO DIRECT OR SCATTERED RADIATION.**



**WARNING: CAUTION: USE OF CONTROLS, ADJUSTMENTS OR PERFORMANCE OF PROCEDURES OTHER THAN THOSE SPECIFICIED HEREIN MAY RESULT IN HAZARDOUS RADIATION EXPOSURE.**

**Follow the instructions contained in this manual for proper installation and safe operation of your laser. Wear protective eyewear; selection depends on the energy and wavelength of the laser beam as well as operating conditions. Consult ANSI, ACGIH or OSHA standards for guidance. ANSI standard (ANSI Z136.1-2000) is available from Laser Institute of America**

**At all times during installation, operation, maintenance or service of your laser, avoid exposure to laser or collateral radiation exceeding the accessible emission limits listed in “Performance Standards for Laser Products,” 21 CFR 1040 10(d).**

## Laser Safety

Laser light poses safety hazards that are not associated with conventional light sources. Special precautions must be observed when working with the Solo Nd:YAG laser. The safe use of lasers requires that all laser users, and people working in the same area as the laser, are aware of the dangers involved.



**Laser beams are intense enough to burn skin, clothing or paint. They can ignite volatile substances such as alcohol, or other solvents. The beam may also cause damage if reflected from some other surface. For this reason it is important that the following precautions are observed.**

- Keep the protective cover on the laser head at all times.
- Avoid looking at the output beam, even diffuse reflections are hazardous.
- Treat back reflections from any optic surface as you would the main laser beam. Even though the energy of such reflections is only a fraction of that contained in the main beam, it is sufficient to cause serious bodily harm, especially to the eye.
- Use protective eyewear at all times. Selection depends on the wavelength and the intensity of the radiation, the conditions of use, and the visual function required.
- Operate the laser at the lowest beam intensity possible, given the requirements of the application.
- Expand the beam wherever possible to reduce beam intensity.
- Avoid blocking the output beam or its reflection with any part of the body.
- Use an IR detector or energy detector to verify that the laser beam is off before working in front of the laser.
- Establish a controlled access area for laser operation. Limit access to those trained in the principles of laser safety.
- Maintain a high ambient light level in the laser operation area to constrict the pupil of the eye, reducing the possibility of injury.
- Post warning signs prominently near the laser operation area.
- Provide enclosures for beam paths whenever possible.
- Set up an energy absorbing target to capture the laser beam, preventing unnecessary reflections and scattering.
- Do not open laser head or power supply. Dangerous voltages and laser energies are present.

## Electrical Safety

The laser head and power supply contain electrical circuits operating at lethal voltage and current levels. Do not attempt to operate the laser with the power supply cover or laser head cover removed. For service, please contact New Wave Research at 47613 Warm Springs Blvd. Fremont, CA, 94539. The phone number for New Wave Research is (510) 249-1550; Fax (510) 249-1551.



Certain procedures such as changing the flash lamp, water filter, or cleaning optical components require removal of the protective systems. It is important that all safety precautions outlined in this manual are observed by anyone using the laser. The most important rule when performing maintenance procedures on this laser is to unplug the power cord from the electrical outlet.

There are no user serviceable parts on the electrical side of the power supply. Service procedures on system electronics must be carried out by New Wave Research.

## **Safety Features**

The following features are built into the Solo Nd:YAG lasers to conform to government regulations and provide safe laser operation.

### **Laser Covers**

The Solo laser head is enclosed in a protective housing that prevents access to radiation in excess of Class I limits, except for the output beam, which is Class IV. The cover also protects against stray radiation from the Solo. Do not remove the cover, except to perform maintenance procedures by a trained person.

### **Interlocks**

The Solo Nd:YAG laser system has a series of interlocks to prevent accidental exposure to dangerous levels of electricity or radiation. In addition, there are interlocks designed to interrupt laser operation if the laser may be damaged. The interlocks are the following

- Laser head cover opened.
- Laser head umbilical detached
- Cooling water temperature too high
- Cooling water flow too low
- Remote interlock interrupted (if installed)

### **Exit Shutter**

The Solo has an exit beam shutter located on the laser head housing. The laser beam may be blocked by closing the shutter. Do not use the exit beam shutter as a method of blocking the beam for more than a few seconds. Turn off the laser if the output beam is not needed for longer time periods.

## **Regulatory Compliance**

New Wave Research suggests that laser users purchase a copy of the American National Standard for the Safe Use of Lasers (ANSI Z136.1-2000). This publication provides recommendations for the safe use of lasers and laser systems that operate at wavelengths between 180nm and 1 mm. The publication is available from the following:

Laser Institute of America  
13501 Ingenuity Dr., Suite 128  
Orlando, FL 32826  
Tel: (407) 380-1553  
Fax: (407) 380-5588  
[www.laserinstitute.org/onlinestore/](http://www.laserinstitute.org/onlinestore/)

**Laser  
Classification**

The governmental standards and regulations specify that the laser must be classified according to the output power or energy and the laser wavelength. The Solo is classified as Class IV based on 21 CFR, subchapter J, part II, section 1040-10 (d). According to the European Community standards, the Solo is classified as Class 4 based on EN 60825-1, clause 9. This manual and other documentation for the Solo will refer to the classification as Class 4.

**CE Declaration of  
Conformity**

Following is the CE Declaration of conformity for the Solo PIV laser system.

**Declaration of Conformity**

We, New Wave Research, Inc. hereby declare that under our sole responsibility the products:

Dual head Nd:YAG Laser System

Model Numbers: Solo PIV I, II, III, IV, and 120

Are in conformity with the provisions of the following EC directives:

- Low Voltage Directive 73/23/EEC
- EMC Directive 89/336/EEC

Standards to which Conformity is Declared:

- EN 61010-1:2001, EN 60825-1: 1994+A11:1996+A2 2001
- EN 01326-1: 1997+A1: 1998+A2: 2001

TUV Report and License No's:

P2072123, E2072122, T2072139, CU2072486

Manufacture's Name and Address:

New Wave Research  
48660 Kato Road.  
Fremont CA 94538  
USA

Date CE Mark Affixed: 2000, 2001

Place: Fremont, CA Date: January 2004

Edward North

VicePresident, Quality

### Location of Safety Labels

Figure 1-1 shows the location of all labels for the Solo laser system. The labels are for safety, certification and identification, and a copy of each label is shown in the following figures.

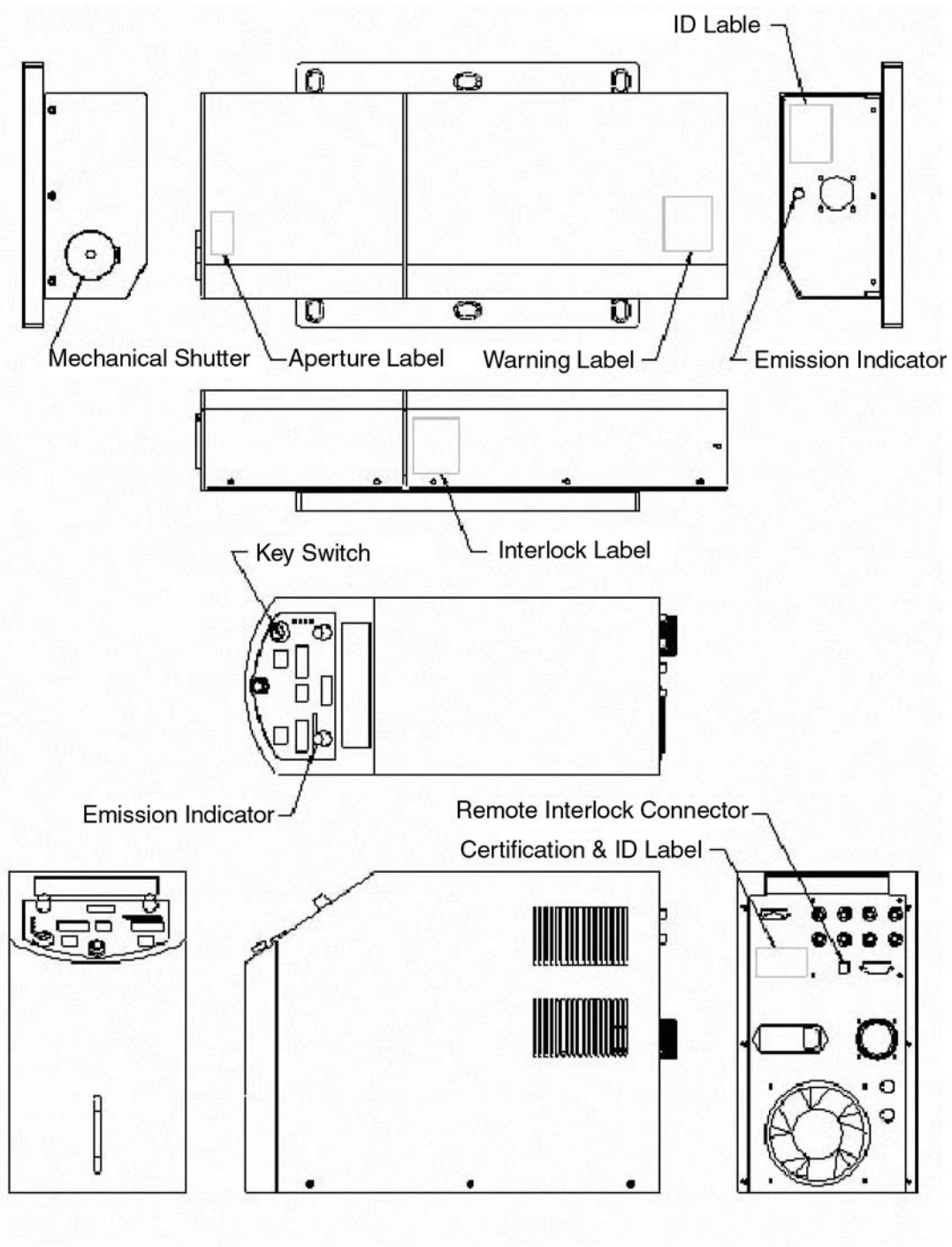

Figure 1-1: Location of Labels



Figure 1-2: Power Supply Identification Label & Certification



Figure 1-3: Laser Head Identification Label

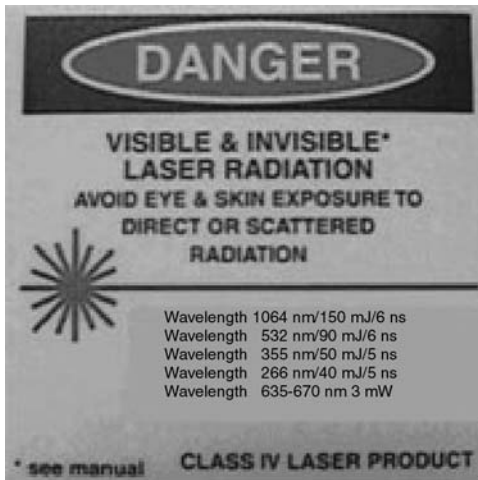

Figure 1-4: Solo I, II, III, IV Warning Label

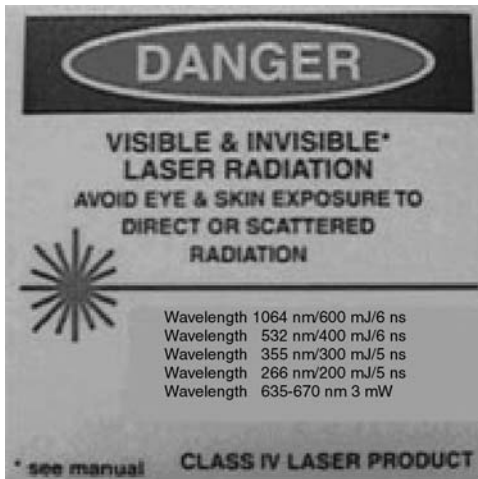

Figure 1-5: Solo 120 Warning Label

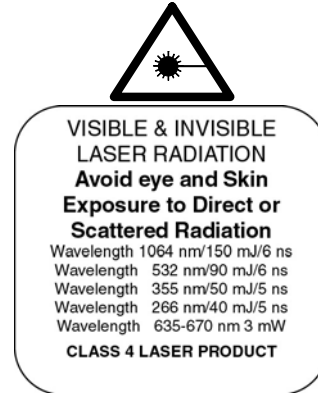

Figure 1-6: Warning Label, International for Solo I, II, III, IV

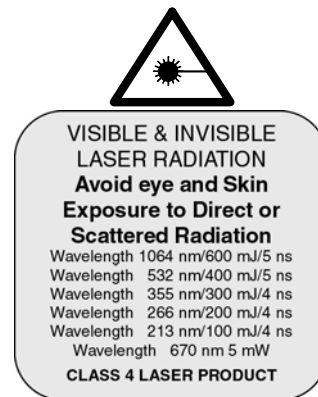

Figure 1-7: Warning Label, International for Solo 120

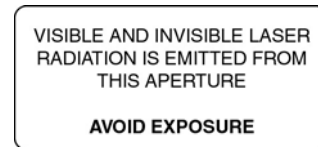

Figure 1-8: Aperture Label

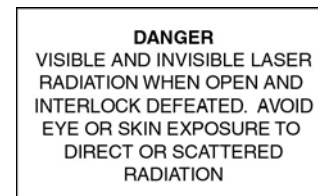

Figure 1-9: Defeatable Interlock Label

Chapter Two

# **Description And Specifications**



## Introduction

This chapter provides an introduction to the Solo Nd: YAG laser system. The optical layout of the head is explained in the following section. This section also includes the location of the harmonic generator. A summary of system specifications is given on the last page of this chapter.

## Optical Layout

This section gives an introduction to the optical layout in the Solo Nd: YAG laser. The standard Solo configuration is a dual head laser with second harmonic generator body, and room for installing the optional attenuator. The system is shown with optional items in Figure 2-1.

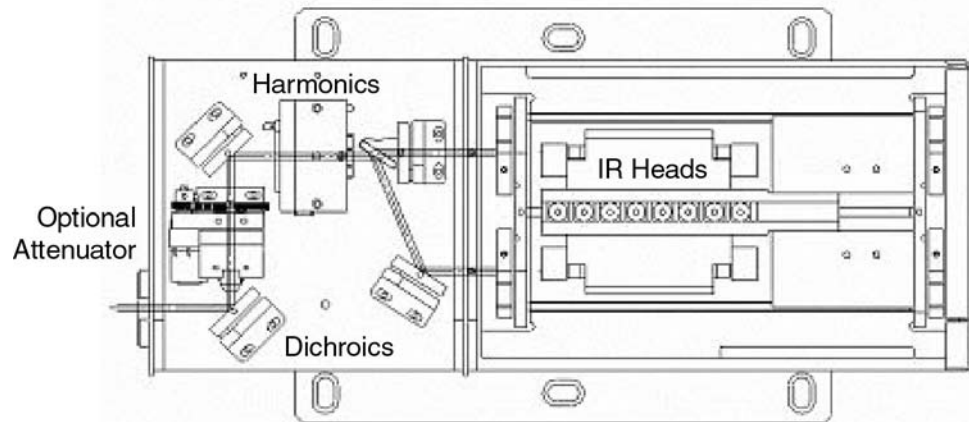

*Solo Laser Head Layout – 532 nm*

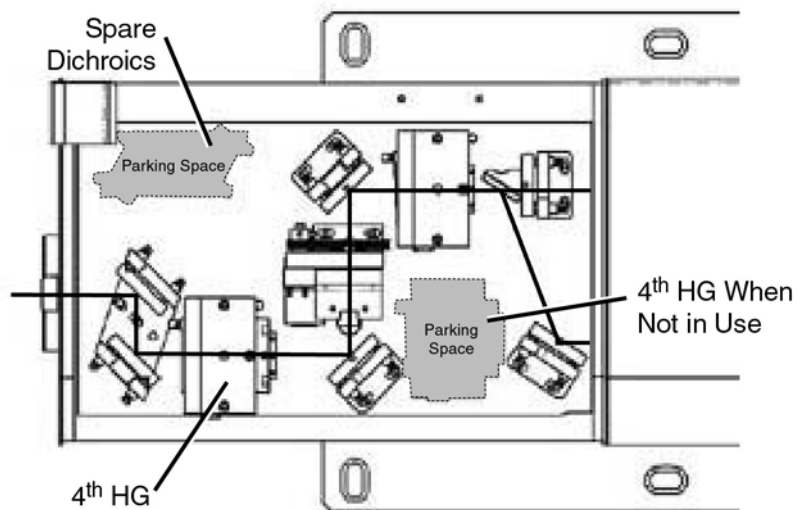

*Solo Laser Head Layout – 266 nm*

Figure 2-1: Layout of Solo Head with Options

The Solo employs a dual flash lamp-pumped Nd: YAG rod head in a thermally compensated resonator to generate radiation at 1064nm. The resonator is very compact, mechanically isolated from the laser housing, which makes the system relatively insensitive to vibrations and temperature change. The IR heads are housed in a separate sealed area that requires no adjustments in normal operation. The only time the IR heads need to be opened is on the rare occasion that a flash lamps needs to be changed during a maintenance procedure.

**Optical Attenuator** The optional optical attenuator serves to control the laser energy without affecting the beam quality. The optical attenuator is designed to work on the 532nm beam, so it is placed directly after the second harmonic generator.

The optical attenuator consists of a half wave plate, followed by a polarizer. The half wave plate is secured to a motorized rotating mount. The servo motor controlled angle is set by input from the control panel. The polarizer is permanently aligned to transmit vertically polarized light.

**Second Harmonic Generation** The 1064nm-laser pulse exits the IR head. The second harmonic at 532nm is generated by passing the IR beam through an angle tuned KTP crystal. The Solo uses Type II phase matching in KTP to generate the second harmonic, so the polarization of the IR beam must be adjusted to maximize SHG intensity. Dichroic mirrors separate the second harmonic from the fundamental light and direct the beam to the output port. The second harmonic light is vertically polarized.

**Third Harmonic Generation (Solo 120)** The third harmonic generator (THG) crystal may be used to provide UV radiation at 355 nm. It is for single-head operation only. The third harmonic generation process is Type I in BBO, created with horizontally polarized fundamental and second harmonic light. A half wave plate for the second harmonic is mounted on the input to the THG housing. The third harmonic output is vertically polarized.

**Fourth Harmonic Generation** The fourth harmonic of Nd: YAG at 266 nm can be generated by doubling the 532 nm second harmonic light. This is done by placing the correct BBO crystal in the optical path and combining two photons at 532 nm to give one photon at 266 nm. The light at 266 nm is separated using a pair of dichroic mirrors to select only the fourth harmonic light. The fourth harmonic light is vertically polarized.

**External Control** The laser system can be fired externally by a pulse generator using the BNC connectors. The laser may also be controlled externally using the TTL Direct Port. TTL signals can be sent to the laser power supply through the female DB 15 connector.



**Safety Interlocks**

One internal interlock, one external interlock, and one mechanical shutter provide protection to the user(s). A cooling water flow interlock switch and a high temperature interlock switch protect the laser system. Opening the laser head trips the internal interlock. The external interlock connector is located at the rear of the power supply, and can be shorted with the supplied connector. The user can install a safety interlock switch to a door or some other device and then electrically connect the switch to the external interlock connector to provide increased safety when using the laser.

**Power Supply**

The power supply controls the Solo Nd: YAG laser, supplying the required power and signals to safely operate the laser. The Solo power supply is built on three levels, with functional groups separated on the three different levels. The top level contains logic level electronics. The middle level contains the high voltage power supply and simmer electronics. The bottom level contains the cooling system.

**AC Power**

The power input module brings AC power to the laser. The power input module contains an AC power On/Off switch.

**Water Cooling System**

The closed loop water cooling system is located completely on the lower level of the power supply. A water pump circulates the de-ionized water from the water-to-air heat exchanger to the laser head. The water circulates through the laser head pump chamber to keep the temperature of the YAG rod at an acceptable level. Part of the water flow is directed through a de-ionization cartridge to maintain the water purity. The cooling control board controls the fan attached to the heat exchanger and monitors the temperature sensor to ensure that the laser operates within temperature specifications.

## Solo Specifications

The following tables show the Solo specifications for the different models available. Specifications are subject to change without notice.

### Solo PIV Products

		Solo I-15	Solo II-15	Solo II-30	Solo III-15	Solo IV-50	Solo 120
Repetition Rate (Hz)		15	15	30	15	50	15
Energy <sup>1</sup> (mJ)	532	15	30	30	50	50	120
	355	–	–	–	–	–	35
	266	NA	NA	NA	NA	NA	25
Energy Stability <sup>2</sup> (±%)	532	4	4	4	4	6	4
	355	–	–	–	–	–	7
	266	NA	NA	NA	NA	NA	9
Beam Diameter (mm)		2.5	2.5	2.5	3.5	3.5	4.5
Pulse Width <sup>3</sup> (ns)		3-5	3-5	3-5	3-5	3-5	3-5
Divergence <sup>4</sup> (mrad)		< 3	<3	<3	<4	<5	<2
Beam Pointing Stability (urad)		<100	<100	<100	<100	<200	<100
Jitter (±ns)		1	1	1	1	1	1

1. Optical losses due to optional attenuator will reduce maximum energy by 10%

2. Pulse-to-pulse for 98% of shots after 30 minute warm up

3. Full width half maximum

4. Full angle for 86% of the energy, at 1/e<sup>2</sup> point

5. For single-head operation. Only one laser may be optimized for 355 nm.

### Physical Characteristics

	Laser Head*		Power Supply		
	Solo I, II, III	Solo IV, 120	Solo I, II, III	Solo IV	Solo 120
Length	13.775" / 350 mm	16.06"/408 mm	18.5" / 470 mm	21.2" / 538 mm	19.0"/483 mm
Width	7.0" / 178 mm	8.0"/203 mm	8.875" / 200 mm	10.6" / 269 mm	8.6"/218 mm
Height	3.187" / 81 mm	4.125"/105 mm	14.375" / 365 mm	15.16" / 385 mm	15.0"/38 mm
Weight	10 lbs. / 4.5 kg	21.5 lbs./9.8 kg	48 lbs. / 22 kg	53 lbs. / 24 kg	55 lbs/25 kg
Length Umbilical	8 ft / 2.4 m	8 ft / 2.4 m			

\* Width and Height include mounting plate

### Operating Requirements

Temperature	70° ± 10° F (21° ± 5° C)	
Relative Humidity	20—80% non-condensing	
Voltage	95—240 V, 50/60 Hz	
Power	Solo I, II, III	15 Hz-300 watts; 30 Hz-500 watts
	Solo 120	500 watts
	Solo IV	1500 watts

Table 2-1: Solo Performance Specifications

Chapter Three

# Installation



## Voltage Requirements

Solo I, II, III, IV and 120 operate from 100-240 VAC, 50/60Hz, single phase power. In addition, the fuses in the power entry module must be changed to match the voltage setting.

## Power Line Fuse

The AC power entry module is located on the back of the power supply. It holds two power line fuses: 250V, 5x20mm, time-lag, high-breaking capacity fuses housed in the AC power input module. The following is a list of fuses that can be used:

Product Type	Manufacturer	90–125 VAC	200–250 VAC
Solo I,II,III	Schurter	19181/6.3A	19181/4A
Solo IV	Schurter	19181/12.5A	19181/8A
Solo 120	Schurter	19181/10A	19181/6.3A

## Laser Umbilical

Connect the main and secondary laser umbilicals to the power supply back panel connectors. **The main umbilical has a circular Amphenol connector that must be completely attached to ensure safe operation. Press the connector into the receptacle as you simultaneously fully engage the connector.**

The secondary laser umbilical carries control signals and connects to the power supply through a D-Sub miniature 15-pin connector. The secondary umbilical must be fully attached by tightening both screws. Connect the cooling system hoses to the cooling system fittings on the back panel of the power supply. Observe the color coding when attaching the cooling system hoses. The blue lines attach to the WATER OUT connection, while the red lines attach to the WATER RETURN connection.

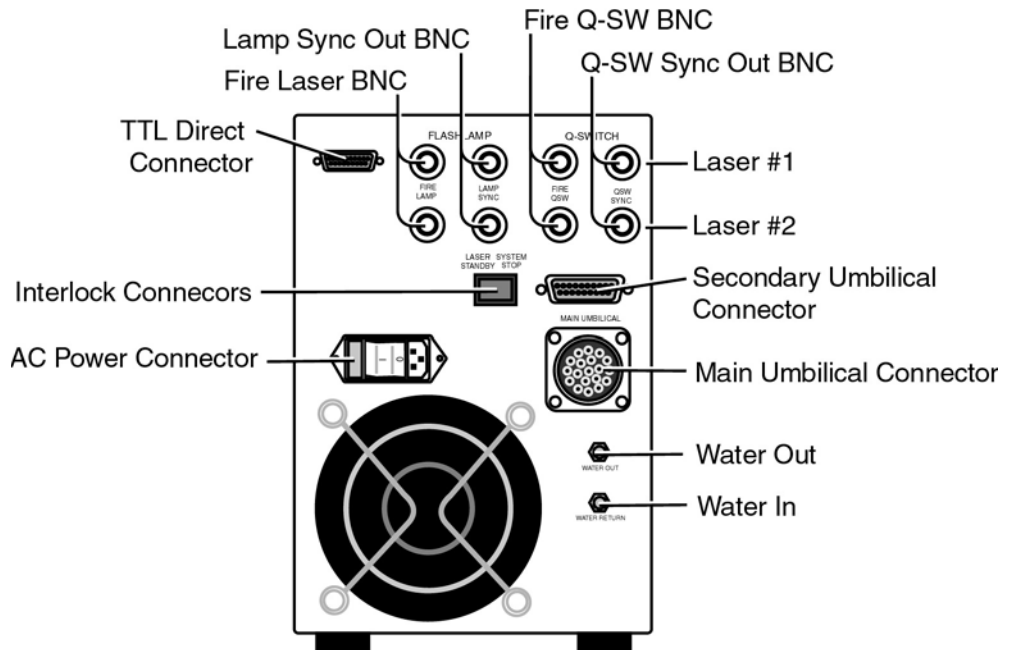

Figure 3-1: Power Supply Back Panel

## Control Panel

The control panel is located on the sloped front panel of the power supply. The control panel is activated when the key switch is turned to the on (I) position.

## Interlock Connector

An external interlock connector is supplied with the system and must be installed before the system can be operated. The purpose of the interlock connector is to provide a method of interlocking the operation of the laser with a safety switch that may be installed on a laboratory door or other location. See Figure 3-1 for the location of the interlock connector.

The laser operation is stopped when the internal or external interlock has tripped the interlock circuit. The user must correct the situation that tripped the interlock and restart the laser to begin operating again.

## Cooling System

Prior to operating the laser, the cooling system must be filled with de-ionized/distilled water. Remove the water fill cap on the front of the power supply. The water level may be seen through the water level window on the front of the power supply.



**NOTE: Only fill the system with de-ionized or distilled water. Use of any other water will damage the system and void the warranty.**

- 1) Close the shutter on the laser head. Connect the power cord to a utility outlet. Turn the Key to the ON (I) position. Turn the main power switch next to the AC input module to the ON (I) position.
- 2) Press the START/STDBY button on the control panel to activate the pump which will pump air out of the water line. When the reservoir runs low, the flow switch will stop the pump.
- 3) Add additional de-ionized (distilled) water until the reservoir is at least 80% full.
- 4) Repeat Steps 2 and 3 until the pump continues running without stopping.
- 5) Press the STOP button. Fill the reservoir to 80%. Replace the water fill cap.



**NOTE: The pump may require priming to initiate water flow. This may be done by squeezing the WATER OUT line on the back of the power supply to force some water into the pump. If that does not work, then disconnect the water hose at the WATER OUT connector and force water into the system from this connector on the back of the power supply. Use the water bottle with the nozzle that is supplied with the system.**

Chapter Four

# Operation





## Starting the Laser

After the installation procedure is completed and the laser safety section is thoroughly understood, the laser may be started. All covers must be installed and the reservoir filled with de-ionized (distilled) water. See Figure 4-1 for location of controls on the control panel.

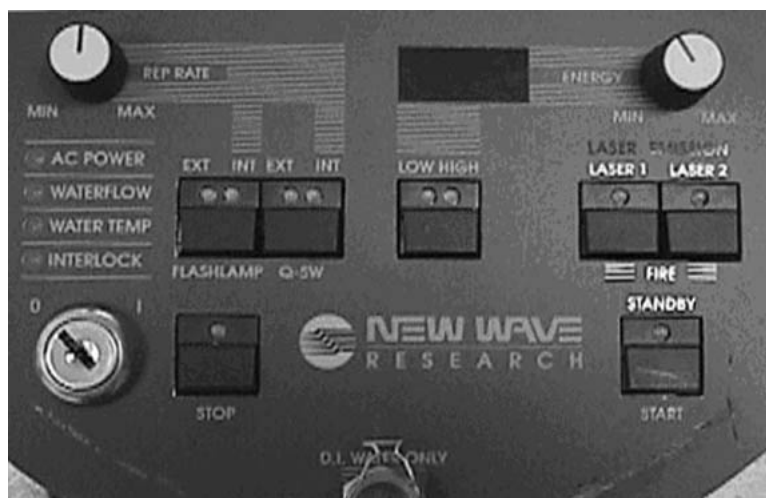

Figure 4-1: Control Panel Layout

- 1) Close the shutter on the front of the laser head.
- 2) Plug the laser power cord into the appropriate single-phase power source. Set the power switch on the AC entry module to the ON (I) position.
- 3) Turn the power supply key switch clockwise to the ON position.
- 4) Rotate the Rep-Rate knob counterclockwise to the minimum, position.
- 5) Press the START/STDBY button on the control panel until the power supply INTERLOCK LED is off and the control panel LASER EMISSION LED is on.
- 6) Note that after the LASER EMISSION LED is illuminated, there is an eight-second delay before laser firing can occur.
- 7) Open shutter when ready to operate safely (see safety section).
- 8) Press the Fire Laser 1, Fire Laser 2 or both buttons on the control panel to initiate laser firing. If both the Fire Laser 1 and Fire Laser 2 buttons have been pressed, the lasers fire alternately. Either laser button can be toggled on and off using the Laser1/Laser2 Fire buttons. Adjust the Rep Rate knob set to the desired setting. Press the energy Hi/Lo button to select desired energy level.

## **Turning the Laser Off**

The laser can be turned off at any time and will shut off automatically if an interlock is interrupted. There is a standard way to turn the laser off and this is performed using the following method.

- 1) Press the OFF button.
- 2) Close the laser shutter (optional).
- 3) Turn the power supply key switch to the OFF position.
- 4) Turn the AC power line switch OFF.

## **Controls and Indicators**

Using the standard control panel, the laser can be operated. All controls and indicators are located on the control panel, including the key switch, LED Power On indicator and INTERLOCK LED indicators.

## **Power Supply**

The AC input module is at the rear of the power supply. The power supply should be plugged into the standard single phase AC line. The main AC Power switch is located on the rear of the power supply and is a part of the AC input module. When the power supply is plugged in and the power switch is in the ON position the AC POWER ON LED on the power supply front panel will illuminate. The KEY switch is located on the power supply front panel. When the key switch is in the ON position the INTERLOCK LED will illuminate. The laser cannot operate with the key in the OFF position. Removing the key will serve to prevent unauthorized laser usage. The key cannot be removed while in the ON position.

The LASER EMISSION LED on the power supply is redundant with the laser emission LED on the laser head. These LED's are illuminated when the laser is powered and can be fired.

The interlock LEDs are located on the front panel of the power supply. The INTERLOCK LED will be illuminated when an internal or an external interlock has been activated. The internal interlock is located in the laser head. The laser head cover cannot be removed without activating this interlock. The Water Flow LED is activated when water flow is not sufficient to safely operate the laser. The Water Temperature LED is activated when the cooling water temperature exceeds the maximum allowable for safe operation, 50C. The external interlock is located on the back of the power supply, and can be connected in series with a laboratory door switch or some other circuit for safety purposes.

**Control Panel** There are several controls and indicators on the control panel to make it easy to operate the laser. Two knobs on the control panel are used to set the repetition rate and to control the optional attenuator. Four buttons on the control panel are used to stop the laser, Fire Laser #1, Fire Laser #2, and to put the laser into Standby mode. LEDs on these switches indicate the actual state of the laser. Two additional buttons set the internal or external trigger mode for both laser heads. LEDs indicate either internal or external mode setting. The energy button sets the energy for both laser heads to Hi or Lo. A LASER EMISSION LED serves as warning when the laser is ready to fire. An optional attenuator provides wide range energy adjustment without affecting beam quality. The three digit display shows energy attenuator setting 999= maximum; 000= minimum. The three turn potentiometer knob controls the energy attenuator setting.

**Interlocks** The laser system is equipped with both internal and external interlock switches. The interlocks are designed to ensure that the laser is operated only when this can be done in a safe manner. The internal interlocks ensure that the laser itself is safe and will not be damaged. The external interlock can be used to ensure that the surrounding facilities and people in the area are protected.

**Internal Interlocks** The laser system has the following internal interlocks:

- 1) Laser head cover opened
- 2) Laser head umbilical detached
- 3) Cooling water temperature too high
- 4) Cooling water flow too low

**External Interlocks** The laser may be interlocked so that laboratory and room doors cannot be entered while the laser is running continuously. The connector on the back of the power supply may be wired so as to interrupt power to the supply, thus disabling the laser. If the external interlock circuit is opened the yellow INTERLOCK LED will be illuminated. To restart the laser, turn the key switch to the OFF position to reset the external interlock switch. The laser may then be started using the procedure given above in the section "Starting the Laser."

**Triggering and Timing** The process of firing the Solo laser requires two steps. The first step is triggering the flashlamp, and the second is triggering the Q-switch. Both the flashlamp and the Q-switch can be triggered either internally or externally, resulting in four operating modes. The trigger mode for each laser is determined by the position of the "Trigger Mode" button on the control panel. The "Ext" position activates the BNC input connectors. The "Int" position allows front panel control. The "Int" and "Ext" modes for Fire lamp and Fire Q switch may be different. The laser can also be controlled using the external TTL control, with input through the DB15 connector on the back of the power supply. The inputs, outputs and implications of the triggering mode are discussed in this section.

**Inputs and Outputs** Two sets of four external BNC connectors (one set for each laser) are located on the back of the power supply. For each laser two sets of the connectors are inputs for triggering the laser. The other two are outputs used for synchronizing the laser to other equipment. The location of the BNC I/O connectors is shown in Figure 3-1, with detail in Figure 4-2.

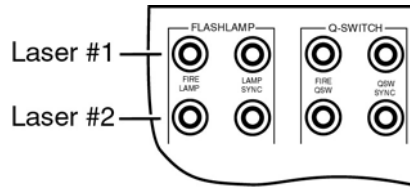

Figure 4-2: Power Supply BNC input/output Connections

- **Fire Flashlamp** – Requires positive 5 volt, 100  $\mu$ s, 5mA pulse. This input will fire the flashlamp. The Q-switch will be fired after the default Q-switch delay if the Q-switch switch is set to the “Int” position.
- **Fire Q-switch** – Requires positive, 5 volt, 100  $\mu$ s, 5 mA pulse. This input will fire the Q-switch at a user-defined time if the Q-switch switch is set to the “Ext” position.
- **Lamp Sync Out** – A 5 volt, 110  $\mu$ s pulse. A positive transition from 0 volts to +5 volts occurs when the flash lamp is fired. With the default Q-switch delay, the laser pulse exits the laser head approximately 180 - 200 microseconds after the Lamp Synch Out signal.
- **Q-Switch Sync Out** – A 5 volt, 110  $\mu$ s pulse. A positive transition from 0 volts to +5 volts occurs when the Q-switch is energized. The laser pulse will exit the laser head approximately 60 nanoseconds after this signal.
- **Q-switch Int/Ext**
  - Int** – The Q-switch will fire after the default Q-switch delay (typically about 180 $\mu$ s). The Q-switch delay is started after a flashlamp fire signal a) has been input into the “Flashlamp Fire” BNC or b) the Fire button has been pressed.
  - Ext** – The Q-switch will fire at a user defined time when a pulse is input to the “Q-switch Trigger” BNC. NOTE: Pulse energy and pulse stability will vary depending upon the timing between the “Fire Laser” signal and the “Fire Q-SW” signal. Refer to Figure 4-3, the timing diagram. The optimum Q-switch setting for the highest pulse energy and the best pulse to pulse stability is 180 – 200  $\mu$ s.
- **Flashlamp Int/Ext**
  - Int** – The flashlamp will be fired by the control electronics at the repetition rate set through the control panel.
  - Ext** – The flashlamp will be fired at a user defined time. The flashlamp will fire after receiving the trigger from the Flashlamp Trigger BNC.

**Internal Triggering** Internal triggering is the simplest way to run the laser. The control electronics provide the necessary triggers to fire the laser. The flashlamp and Q-switch switches should both be, in the INT position. The repetition rate and energy can be changed by the controls on the control panel.

The Rep Rate knob determines the operating mode, 1 shot or variable. In 1 shot mode (Rep. Rate control set to MIN), the laser is fired once per second when the Fire button on the control panel has been pressed. With the rep rate knob set above “Min.” the laser fires at the repetition rate set by the control knob.

Two output signals are available to synchronize the Solo and the user’s setup. The relationship between the synchronization pulses and the laser pulse are shown below in Figure 4-3.

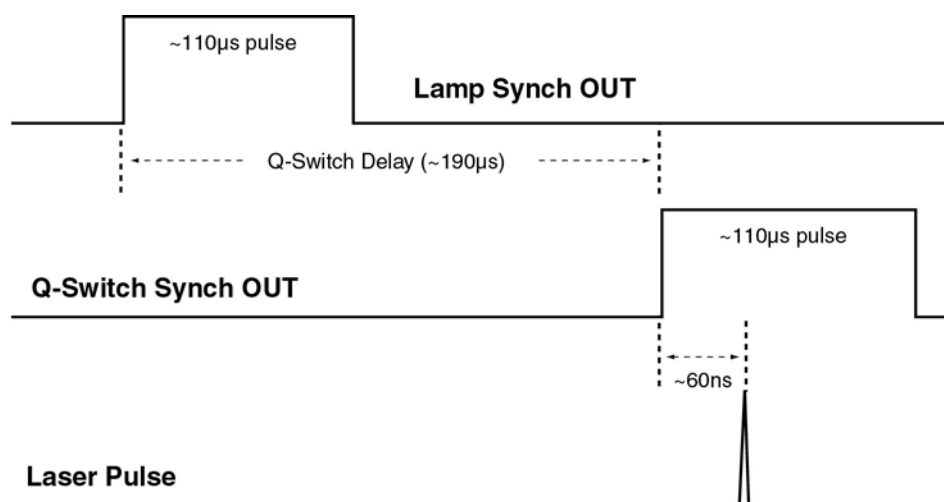

Figure 4-3: Timing Diagram for Internal Triggering

**External Triggering** External triggering gives the user control over the timing of each laser pulse. The user must supply TTL pulses to Laser 1 and Laser 2 flashlamp and Q-switch BNC’s with the appropriate delay. The Flashlamp and Q-switch switches should both be in the EXT position. The delay between the flashlamp and the Q-switch TTL fire pulses is important to obtain the optimum laser performance. The timing diagram for external triggering is shown in Figure 4-4.

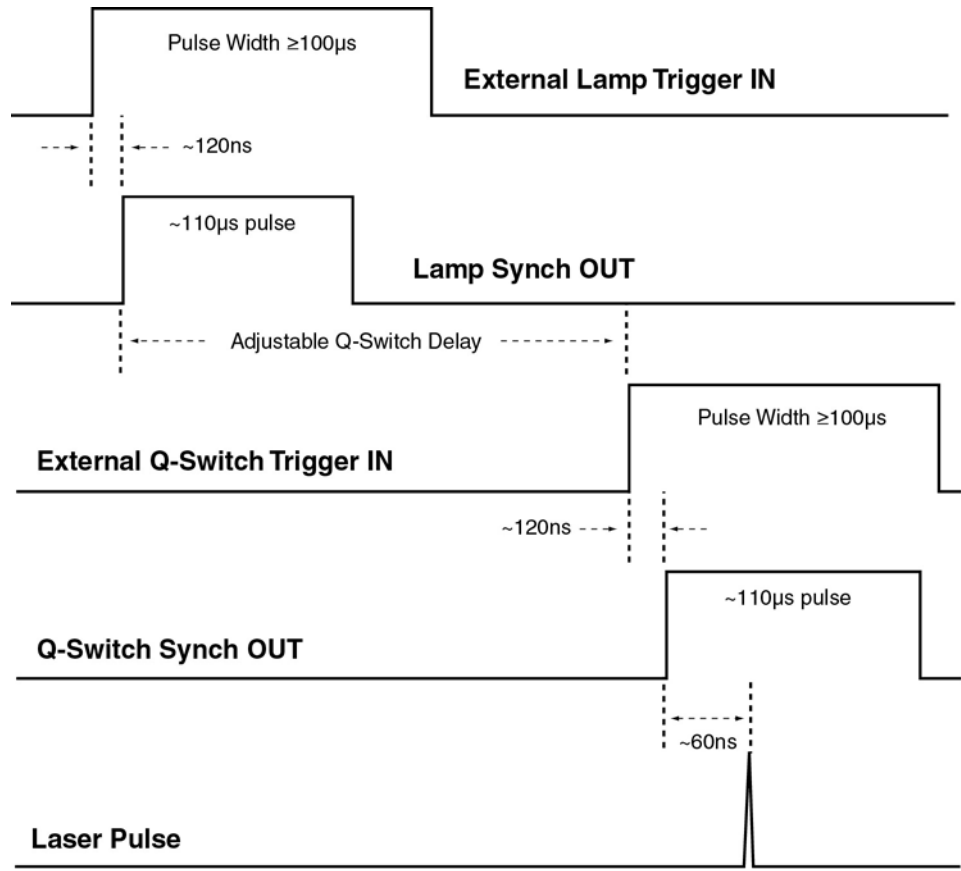

Figure 4-4: Timing Diagram for External Triggering

### External Q-Switch Triggering

External Q-switch triggering allows the user to fire the Q-switch externally while the internal electronics control the flashlamp firing. The user must supply a TTL pulse to the Q-switch trigger with the appropriate delay following the internal flashlamp pulse. The Flashlamp switch should be set to (Int) and the Q-switch should be set to (Ext). The delay between the flashlamp and the Q-switch TTL fire pulses is important in getting optimum laser performance. The recommended Q-switch delay for optimum laser performance is 180 – 200  $\mu\text{s}$

The Rep rate knob on the control panel allows the user to set the rep rate of the laser. The flashlamp fires at the repetition rate set by the control knob. Furthermore, the flashlamp begins firing when the Fire button on the control panel is pressed.

The Q-switch must be fired using a user supplied TTL pulse at the Q-switch fire BNC. The Flashlamp Synch Out pulse may be used to trigger an external delay generator that creates the Q-switch fire TTL pulse.

### External Flashlamp Triggering

External flashlamp triggering allows the user to fire the flashlamp externally while the internal electronics control the Q-switch firing. The user must supply a TTL pulse to the flashlamp trigger to start the laser firing sequence. The internal electronics will fire the Q-switch after the default delay. The Flashlamp switch should be set to (Ext) and the Q-switch should be set to (Int). The delay between the flashlamp and the Q-switch TTL fire pulses is predetermined by the laser control electronics.

### External TTL Direct Triggering

External TTL direct triggering allows the user to externally control many laser parameters. User supplied TTL control signals are sent through the TTL Direct DB 15 connector on the back of the power supply. The impedance of the signal inputs is approximately 1 MegaOhm. Pin 2 must be set Hi to enable TTL Port. The flashlamp and Q-switch should both be set in the Int position. The control electronics provide the necessary triggers to fire the laser in the selected mode.

The pin assignments for TTL Direct Port connector are shown in Table 4-1.

Pin	Function	Description
1	Enable Laser	Laser will go to standby mode from stop mode. Fan & pump will be running.
2	Enable TTL Direct Port	High at this pin will enable the TTL Direct Port. Laser will be under the control of the TTL signals.
3	High/Low	High at this pin will allow both lasers to fire at high-energy setting. Note: it is better to start at low.
4	Fire Lamp 1	Laser will fire Flash lamp 1
5	Fire Q SW 1	Laser will fire Q-SW 1. The delay of the Q-SW signal will affect the laser output energy.
6	Fire Lamp 2	Laser will fire Flash lamp 2
7	Fire Q SW 2	Laser will fire Q-SW 2. The delay of the Q-SW signal will affect the laser output energy.
8	0-5 Attenuator SET	This is a 0-5V analog input signal. It is used to control the optical attenuator. +0V- means minimum energy output. +5V- means maximum energy output.
9	Laser Ready	This signal will go high 10 seconds (CDRH Delay) after the Enable Laser Signal has been triggered. Once this signal comes up the laser is ready to fire.
10	Ground	
11	Ground	
12	Ground	
13	Ground	
14	Ground	
15	+12 volts	+12V can be used for the power of simple remote control device. Capable of delivering 100mA.

Table 4-1: TTL Direct Port

### Harmonic Generators

Solo laser systems are purchased with a second harmonic generator. The desired wavelength is generally selected using dichroic mirrors to reflect the selected wavelength and transmit the undesired wavelengths to a beam dump.



**The following procedures require the laser to be operated with the laser head cover open and the interlock defeated. Stray IR or visible laser radiation may be generated. For safety reasons room access should be limited and everyone in the room should wear safety glasses.**

## Second Harmonic Generator

The second harmonic generator is used to produce visible radiation at 532nm. One IR beam is polarized horizontally and one is polarized vertically for the purpose of polarization combining the beams from Laser #1 and Laser #2. The second harmonic generation process is Type II in KTP, so the fundamental polarization vector must be oriented at 45° with respect to the x-axis. This is accomplished with a half wave plate that is mounted on the input to the SHG housing. The SHG crystal is oriented so that the second harmonic output is vertically polarized.

The second harmonic generator seldom requires adjustment. However, the following procedure may be used to adjust the harmonic generator if necessary.

Release the half wave plate set screw on the top of the second harmonic generator housing – turn it only a little, just enough so the plate can be turned, being careful the plate doesn't fall out, See figure 4-5. Using a pin or paper clip, rotate the half wave plate to maximize the green energy output.

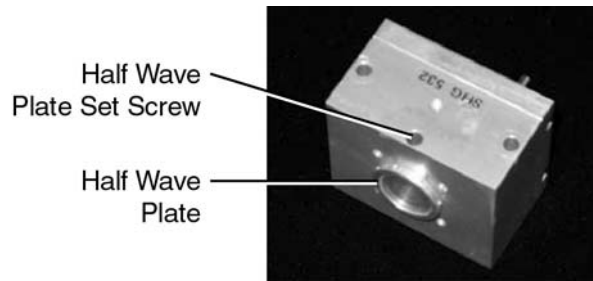

Figure 4-5: Half Wave Plate Adjustment

Use the adjusting screw to rotate the crystal angle to optimize the phase matching angle and maximize green energy output. See figure 4-6.

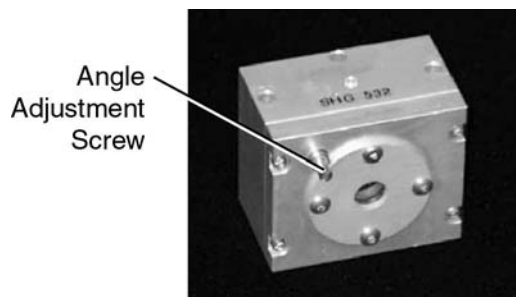

Figure 4-6: Second harmonic Angle Adjustment



**NOTE: DO NOT DISASSEMBLE THE HARMONIC GENERATOR. THE CRYSTAL INSIDE IS HYGROSCOPIC. DUST, DIRT AND HUMIDITY WILL DESTROY THE CRYSTAL.**



## Solo PIV Alignment



The alignment is optimized by adjusting the beam from laser 2 to overlap the beam from laser 1 as shown in Figure 4-7. The beam from laser 1 is fixed and cannot be adjusted, so beam overlap is optimized by steering the beam from laser 2. This is an iterative process, switching between overlap measurements at the laser head and at a distance several meters from the head. The following procedure provides a tested method to align the beams from the two laser heads.

**The procedures described below require the laser to be operated with the harmonic head cover open and the interlock defeated. Stray IR and visible laser radiation are generated. For safety reasons room access should be limited and everyone in the room should wear safety glasses.**

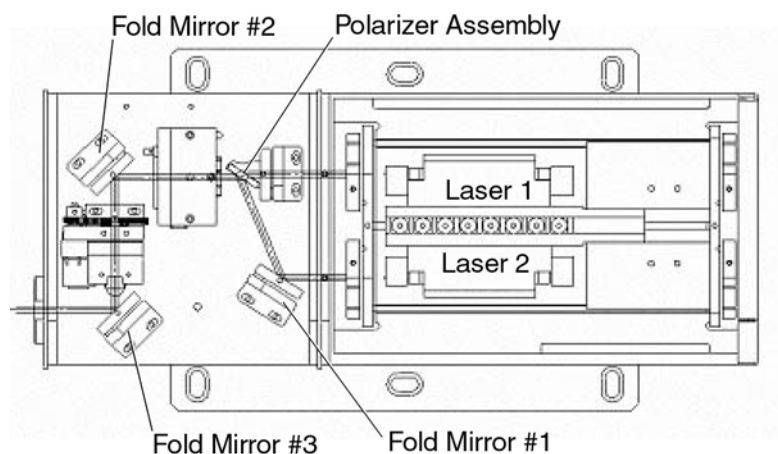

Figure 4-7: Solo PIV Beam Overlap Adjustment

- 1) Remove the smaller optics head cover to provide access to the beam combining optics and second harmonic generator. Install the interlock defeat mechanism.
- 2) Put both lasers into standby mode with the Energy switch set to the Low position.
- 3) Observe the overlap of the two beams at the point one to two meters from the laser head. Adjust the polarizer assembly mount so that the beam of Laser #2 overlaps the beam of Laser #1. Note that the top adjustment screw on the mirrors controls vertical beam motion, while the bottom adjustment screw controls horizontal motion.
- 4) Observe the overlap of the two beams from the first measurement point back to the laser. You have finished the alignment if the beams overlap over the entire distance. If not, continue with step 5.
- 5) Fire laser #1 and observe the position of the visible beam on the Fold Mirror #2.

- 6) Fire laser #2 and note the position of the beam on the mirror, relative to the beam from laser #1. Adjust the Fold Mirror #1 to overlap the two visible beams immediately after the second harmonic generator – only a slight turn of the adjustment screws is necessary. Note: The beam will shift and the beam combining polarizer will have to be readjusted.
- 7) Observe the overlap of the two beams at a point 1-2 meters away from the laser head.
- 8) Adjust the polarizer assembly mount to optimize the overlap of the two beams.
- 9) Repeat steps 5 – 8 to get the optimal overlap between the beams from laser #1 and laser #2. The overlap can be observed along the beam line from the laser head exit for several meters.
- 10) Turn off both lasers and reinstall the secondary head cover. Check the alignment with both lasers operating at the desired energy.

Chapter Five

# **Maintenance, Service, and Troubleshooting**



## Maintenance and Service

The laser is a high power laser system and it is important to keep the laser clean and well maintained. This section describes several procedures that should be performed on a regular basis to ensure that the laser system works properly for many years.

The most common reason for decreased performance in a high power laser system is dirty and/or damaged optics.

- Keep the laser in a clean environment free from dust and moisture.
- Inspect the optics in the laser once per month for burn marks, dust or scratches.

## Recommended Scheduled Maintenance

**Weekly** – Operate the laser system at least 30 minutes per week. If the laser will not be operated for more than one week, drain the water from the cooling system. (To drain the water, follow steps 1 – 3 in the section “De-ionization Cartridge Replacement.”)

**Monthly** – Check the system for leaks. Check optics for dirt or damage. Clean optics if necessary with methanol.

**Yearly** – Change DI cartridge.

**As Needed** – Change flash lamps.

## Cooling System

If a noticeable drop in laser energy has occurred, it may be necessary to flush the cooling system to remove any contaminants. Carbon dioxide from the air and metal ions will naturally collect in the cooling water over time. Running the pump allows the de-ionizing filter to purify the water.



**Circulate the cooling water by running the laser power supply and pump at least 30 minutes each week. This is essential to prevent the build-up of contaminants in the system, which will be deposited on the flash lamp and laser rod resulting in decreased output energy. If you cannot run the laser at least 30 minutes each week, you must completely drain the cooling system and blow clean, dry compressed air or nitrogen through the water lines to insure there is no water in the laser head or power supply.**



**WARNING!!! Never add tap water to the cooling system. Only de-ionized or distilled water may be used.**

## De-ionization Cartridge Replacement

The de-ionization cartridge must be replaced approximately once every year. The following procedure can be used to replace the de-ionization cartridge.

- 1) Place the Energy switch in the Low position.
- 2) Disconnect the lower WATER RETURN hose from the back of the power supply and hold it over a drain container.
- 3) Depress the START/STDBY button on the control panel to start the pump. The pump will force the cooling water from the hose into the drain container. Repeatedly press the START/STDBY button until all water has been pumped out of the system. Press the OFF button on the control panel to stop the pump.
- 4) Turn the power supply off with the switch at the AC power entry module on the back of the power supply, and disconnect the AC power cord from the power supply.
- 5) Remove the power supply cover. Note the "Flow Direction" printed on the old cartridge.
- 6) Disconnect the hose from the top of the de-ionization cartridge, Figure 5-1.
- 7) Disconnect the hose from the bottom of the de-ionization cartridge, Figure 5-1.

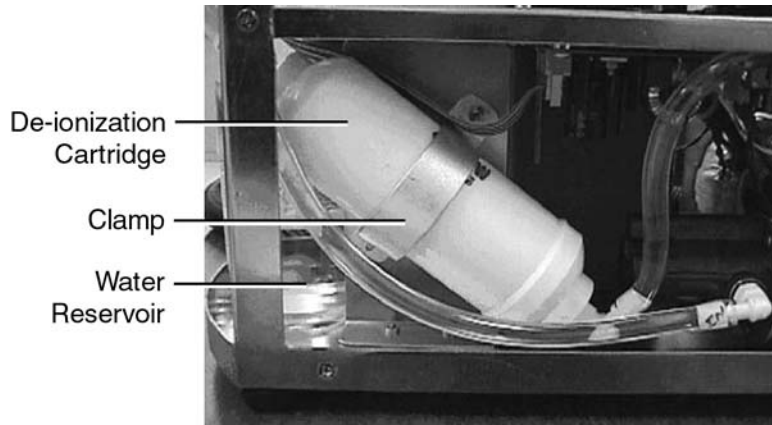

Figure 5-1: Cooling System in the Power Supply

- 8) Unscrew the clamp holding the de-ionization cartridge in place and remove the de-ionization cartridge.
- 9) Connect the hose to the bottom of the new de-ionization cartridge. Reconnect the water hose to the top of the cartridge. Secure the water hoses on the cartridge connectors using tie wraps. Install the new de-ionization cartridge. Screw the clamp back in to secure the cartridge in place. Make sure the "Flow Direction" is the same on the new cartridge as it was on the old cartridge.

- 10) Refill the cooling system with de-ionized or distilled water and run the system briefly to check for leaks before replacing the power supply cover. See Chapter 3, Installation, in the cooling system section for detailed instructions. Disconnect power cord before replacing cover.

## Flashlamp Replacement

The flashlamp needs to be changed when the specified energy cannot be achieved or if the laser energy fluctuates significantly from shot to shot. This can be seen over the course of several hundred pulses. The flashlamp should be useful for at least 30 million shots. Use the following procedure to install a new flash lamp.

**NOTE: Both flash lamps should be replaced at the same time. It is recommended that the user wear finger cots or latex gloves to insure that no dirt or contaminants are deposited on the flash lamps or laser optics.**

- 1) Place the power supply lower than the laser head.
- 2) Turn the power supply off with switch at the AC power entry module on the back of the power supply, and disconnect the AC power cord from the power supply.

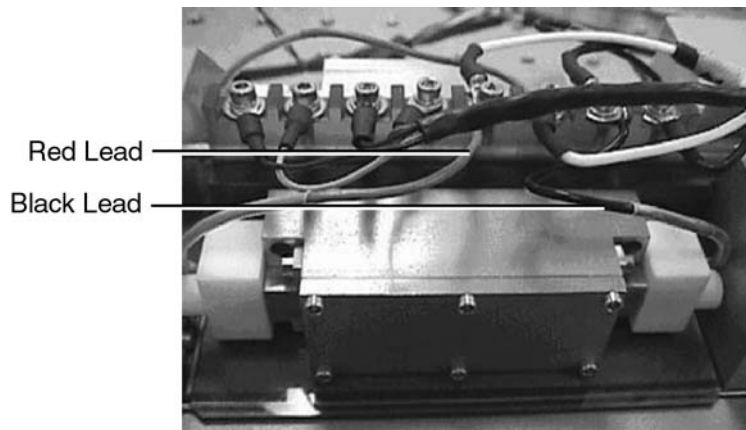

Figure 5-2: Removing Leads to Replace Flashlamp for Solo I, II, III

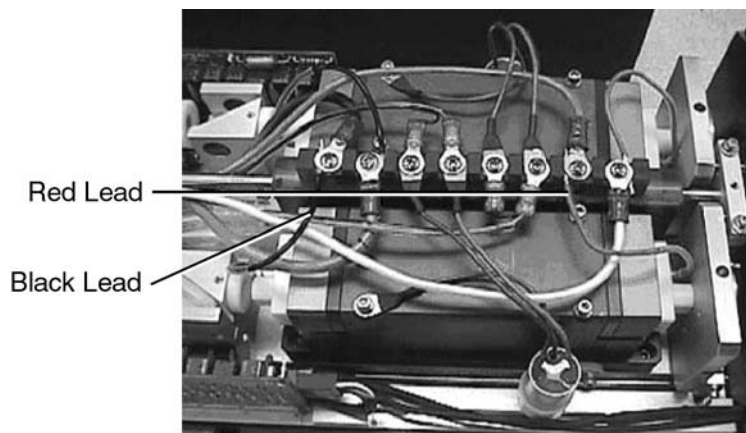

Figure 5-3: Removing Leads to Replace Flashlamp for Solo 120 and IV

- 3) Remove the RED and BLACK flashlamp leads from the terminal strip, Figures 5-2 and 5-3.
- 4) There are four screws, accessible from the side (Solo I, II, III, 1V), that secures the pump chamber to the base plate – see Figure 5-4. The four screws that secure the pump chamber for the Solo 120 are located on the top of pump chamber for pump chamber see Fig 5-5.

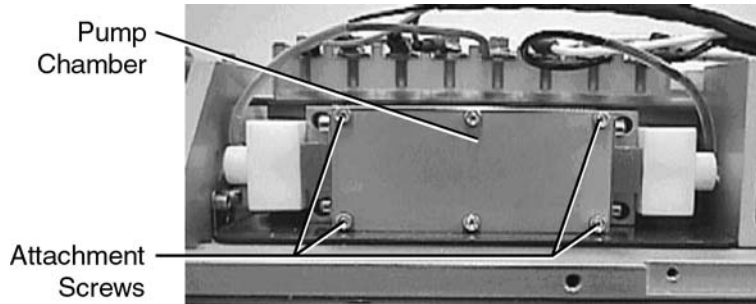

Figure 5-4: Pump Chamber Attachment Screws for Solo I, II, III

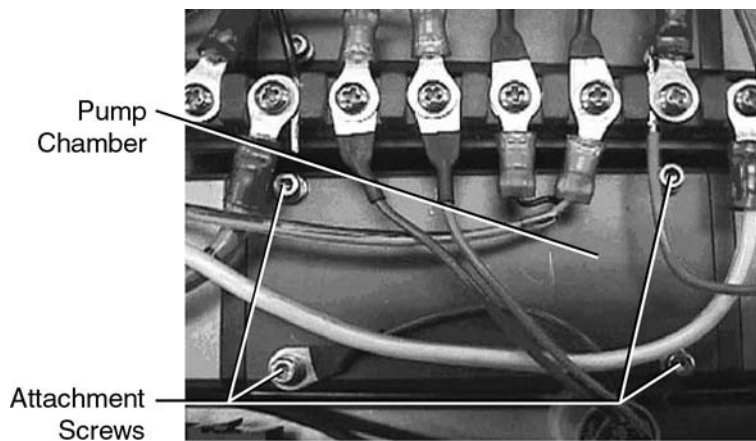

Figure 5-5: Pump Chamber Attachment Screws for Solo 120 and IV

- 5) Remove the pump chamber from the laser head and carefully place it on a clean surface.
- 6) Remove the pump chamber end caps that secure the flashlamp within the pump chamber, Figure 5-5.



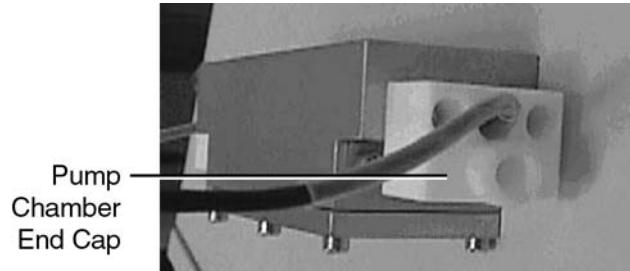

Figure 5-6: Removal of Pump Chamber Assembly End Cap for Solo I, II, III

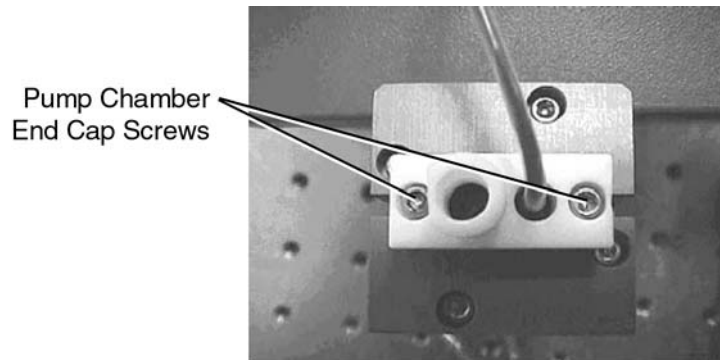

Figure 5-7: Removal of Pump Chamber Assembly End Cap for Solo 120 and IV

- 7) Carefully straighten the lamp leads and remove the flash lamp from the pump chamber. Note the position of the RED and BLACK lamp leads.
- 8) Install the new flashlamp with the RED and BLACK leads on the same side as the original lamp. Bend the lamp leads so that they are perpendicular to the lamp.

Do not touch the glass surface of the lamp with your bare fingers, or other skin. This may leave grease marks that will degrade lamp performance and may shorten lamp lifetime

- 9) Slide the o-rings over the flashlamp lead and into place using tweezers. See Figure 5-8. Reinstall the pump chamber end caps and carefully tighten the screws to hold the lamp in place.
- 10) Carefully check the two o-rings on the resonator side plate, Figures 5-8 and 5-9. The o-rings seal the pump chamber against water leaks. Ensure that the o-rings are in place, before replacing the pump chamber in the resonator.

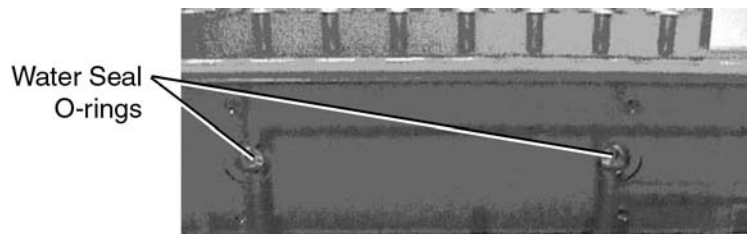

Figure 5-8: Pump Chamber Water Seal O-rings for Solo I, II, III

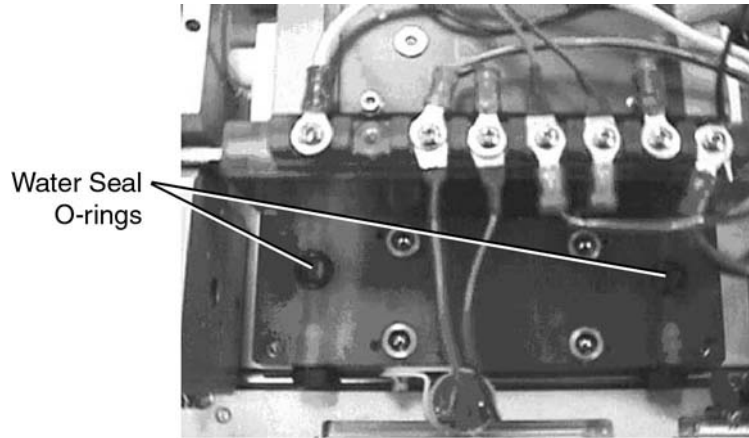

Figure 5-9: Pump Chamber Water Seal O-Rings for Solo 120 and IV

- 11) Reinstall the pump chamber, observing that the Nd:YAG rod is in line with the mirrors and the black flashlamp lead is on the end by the Q-switch. Tighten the four screws to connect the pump chamber to the side plate (Solo I, II, III, IV) or bottom plate (Solo 120).
- 12) Reconnect the RED and BLACK flashlamp leads, as shown in Figures 5-2 & 5-3.
- 13) Start the power supply and check the cooling system for leaks before replacing the laser head cover. Disconnect power before replacing the laser head cover.
- 14) Both flash lamps should be replaced at the same time. Repeat the above procedure for the second laser head.

## Trouble-shooting

This section lists a number of conditions that may be observed during the lifetime of the laser system. Following the list of conditions is a set of procedures that may be used for resolving specific conditions to improve laser performance.

## Observed Conditions

To use this section, find the observed condition in this section that matches the condition of the laser. Follow the recommended procedure to correct the situation. If the problem cannot be resolved by following the procedure then phone New Wave Research at (510) 249-1550; FAX (510) 249-1551; or e-mail [lasers@new-wave.com](mailto:lasers@new-wave.com) to get technical support for the laser.

Observed Condition	Recommended Procedure
Laser does not start	Procedure 1
Laser starts, but no light is emitted	Procedure 2
Low output energy	Procedure 3
Unstable laser energy	Procedure 4
Clipped beam profile	Procedure 5
Low second harmonic energy	Procedure 6

Table 6-1: Observed Conditions

## **Recommended Procedures**

The following procedures should be followed to resolve the observed conditions listed in the section above. Please contact New Wave Research at (510) 249-1550; FAX (510) 249-1551, for more detailed information regarding these procedures.

### Procedure 1 Laser Does Not Start

If the laser does not start, please check the following points:

- The laser AC power cord is plugged in and the outlet has power.
- The power switch on the AC power entry module is in the ON (I) position.
- The key switch on the power supply is turned to the ON position, and the AC power light is illuminated.
- The energy switch is in the Low position.
- The water reservoir has been filled with distilled water.
- The umbilical from the laser head is securely attached to the power supply.
- The interlock-shorting plug is secured on the connector located on the back of the power supply.
- If the external interlock is utilized, ensure that the switch on the door interlock or other device is activated.
- Check all laser internal interlocks: low water flow; over temperature; and laser head cover.
- Check Fuses

### Procedure 2 Laser Starts But No Light is Emitted

When the laser is in Standby mode pressing the Fire button will cause the laser to begin firing. The LED above the Fire button on the control panel should flash at the same rep rate as the laser.

- Check that the mechanical shutter is open.
- Energy switch is set to Hi.
- For internal triggering, check that the flashlamp and trigger select switches on control panel are both in the “Int” position.
- For external triggering, check that the flashlamp and trigger select switches are in the desired positions. Check that TTL pulses are present at the BNCs. Check that the Q-switch delay is correct, typically 180-200 microseconds.

### Procedure 3 Low Fundamental Output Energy

If the laser output energy is low, please check the following points:

- The energy switch is set to high
- If the optional attenuator is installed, ensure that the attenuator knob is rotated fully clockwise to the maximum energy/minimum attenuation setting.
- Check the optics to ensure that they are clean, and that none of the optics have any burn marks.

**Procedure 4**  
**Unstable Laser Energy**

The pulse stability for the Solo Nd:YAG laser is specified as 4-6% at 532 nm for greater than 98% of pulses for 10,000 pulses after 30 min warm up. If the pulse stability at 532 nm does not meet this specification, then check the following:

- Check that the laser is running at full energy, with the energy switch to high.
- Check the number of shots on the flash lamp. This can be estimated from the date of the last flash lamp change and the average usage per day. If the number of shots fired exceeds 30 million shots, change the flash lamp.
- For fluctuations in the laser energy in the harmonics check that the laser is running at full energy.

Call New Wave Research if it is not possible to increase the laser pulse energy by this procedure.

**Procedure 5**  
**Clipped Laser Beam**

The output beam of the Solo Nd:YAG laser should be round, symmetric with even energy distribution. An object in the beam path may clip the laser beam resulting in an output beam that appears asymmetric, with a sharp edge. If the output beam is clipped, check the following:

- This procedure must be done at the lowest energy setting.
- Check the beam path to ensure that there are no foreign objects in the path.
- Change the energy switch setting to low. Trace the beam through the head examining the beam profile after each optic. Try to determine which optic is responsible for clipping the beam. Use an infrared card to view the beam before the harmonic generators.
- Check the dichroic mirrors and mounts to ensure that they are not clipping the beam.
- Check that the mechanical shutter is fully open and is not clipping the beam
- When you have found the object that is responsible for clipping the beam, correct the situation and ensure that the beam path is fully clear.

**Procedure 6**  
**Low Second Harmonic Energy**

If the second harmonic output energy is low, please check the following points:

- Check the dichroic mirrors to ensure that the SHG mirrors are clean and undamaged.
- Adjust the SHG crystal angle to maximize the output energy.
- Adjust the wave plate on the input to the SHG housing to maximize the energy.
- If the optional attenuator is installed, ensure that the attenuator knob is rotated fully clockwise to the maximum energy/minimum attenuation setting.

- Remove the second harmonic generator housing from the laser head and check to ensure that all surfaces are clean and undamaged.
- Check that the fundamental energy meets specifications. Ensure that the laser has been operating at least ten minutes to achieve an optimum operating temperature.
- Check to insure the harmonic generator heater is plugged in and operating (only for the Solo III, IV, 120).