

## MICROSCOPE UNITS AND OBJECTIVES (UV, NUV, VISIBLE & NIR REGION)

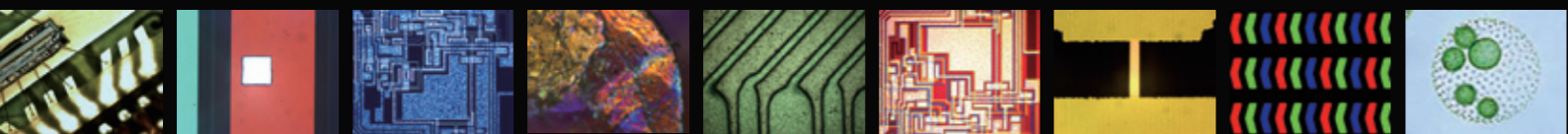



Many of today's ultra-microscopic manufacturing technologies require sub-micron accuracy. Mitutoyo produces microscope systems with advanced features that combine optical and precision measurement technologies developed by us over a long period of time. Mitutoyo microscopes can be integrated into manufacturing systems, research and development equipment, and product inspection lines. Contact your nearest Mitutoyo Sales Office for further details on standard product specifications as well as custom-designed microscopes to best fit your application.



Ref.: "Microbio-World Ver.7,  
 ([http://elife.miyakyo-u.ac.jp/opac/2008/03/cd\\_2.html](http://elife.miyakyo-u.ac.jp/opac/2008/03/cd_2.html))

# A wealth of Applications

## Integration example

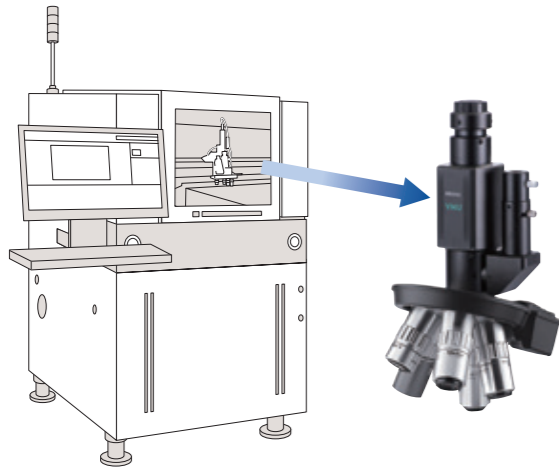

The VMU series provides a wide range of small, lightweight microscope units to be integrated into automatic optical inspection devices (AOI) and repair equipment of all sizes.

## Digital microscope systems

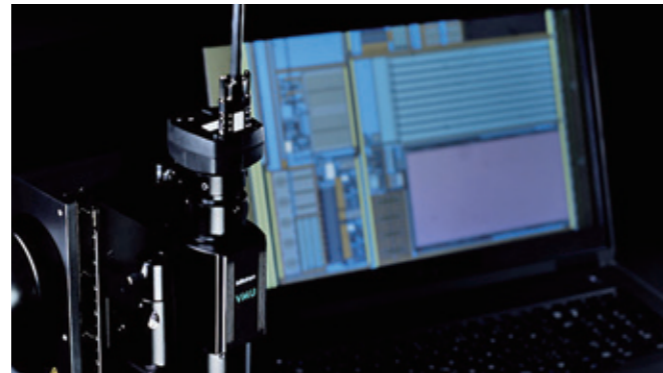

By installing a digital camera on a microscope the VMU provides a simple and compact system which allows microphotography and simultaneous external monitor observations. The VMU can be used in vertical and inverted positions according to your application requirements.

Using a simplified stand, it can be used as a compact microscope.

- > Microphotography and observation of metallic, resinous and printed surfaces
- > Micro-fluid analysis
- > Cell and microorganism observation/analysis



See video from here.



<https://bcove.video/3Kp07QU>

## Laser applications



UV laser application using VMU-L4B  
(Source of photographs: V-Technology Co.,Ltd.)



Flaking of polyimide membrane



SEM photograph of IC surface after removing upper layer



UV laser application using VMU-L4B  
(Source of photographs: HOYA CANDEO OPTRONICS CORPORATION)



Color filter working

Objectives compatible with YAG lasers (1064 nm, 532 nm, 355 nm and 266 nm) allow high precision and quality working.

Using a simplified stand, it can be used as a compact microscope.

- > Peeling off protective films and organic thin-films
- > Cutting of IC wiring (Au, Al) and exposure of lower layer pattern
- > FPD defects repair
- > Photomask repair
- > Marking, trimming, patterning, spot annealing and scribing

Various lasers are supported including femtosecond lasers.  
(For details, please inquire.)

## IR analysis/inspection

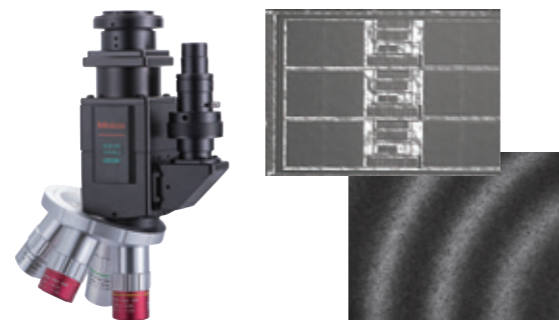

Optical systems using Mitutoyo M Plan Apo NIR objectives cover a wide range of wavelengths from visible to infrared providing solutions on the production line and in the laboratory. Nondestructive inspection is made possible by using an infrared source.

- > Thickness measurement of LCD thin-film and silicon board film
- > Internal inspection/analysis and 3D evaluation of MEMS devices
- > Internal observation of IC packages, void inspection/evaluation sensor of wafer junctions
- > Spectral characteristics analysis using an infrared source

## Dual-camera (high & low magnification) observation

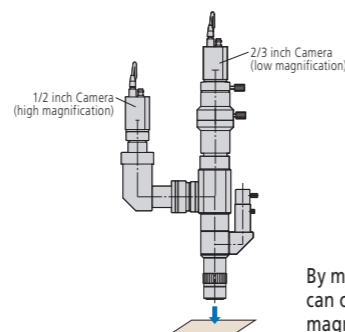

By mounting two Cameras on VMU-LB you can observe the same area at different magnifications simultaneously.

## Contents

Microscope unit for incorporating in Equipment <b>VMU</b> .....	6
Microscope unit <b>FS70</b> .....	14
Objectives for Bright-field (long working distance) <b>M Plan Apo</b> .....	18
Objectives for Bright-field (with cover-glass thickness compensation) <b>G Plan Apo</b> .....	20
Objectives for Bright/Dark-field (long working distance) <b>BD Plan Apo</b> .....	21
Near-infrared Objectives for Bright-field <b>M Plan Apo NIR</b> .....	22
Near-infrared Objectives for Bright-field (with cover-glass thickness compensation) <b>LCD Plan Apo NIR</b> .....	23
Near-ultraviolet Objectives for Bright-field <b>M Plan Apo NUV</b> .....	24
Near-ultraviolet Objectives for Bright-field (with cover-glass thickness compensation) <b>LCD Plan Apo NUV</b> .....	25
Ultraviolet Objectives for Bright-field <b>M Plan UV</b> .....	26
Ultraviolet Objectives for Bright-field (With cover-glass thickness compensation) <b>LCD Plan UV</b> .....	27
Tube lens <b>MT</b> .....	28
Objectives for Measuring Microscopes <b>ML</b> .....	30
Objectives for Centering microscopes <b>CF</b> .....	31
Wide field of view Eyepieces & Reticles <b>WF</b> .....	32
Optional accessories of VMU, WIDE VMU and FS70 <b>Stand, Stage, Illumination Unit</b> .....	33
<b>Dimensions (VMU/WIDE VMU/FS70)</b> .....	34
<b>Reference:</b> Specifications of Objective Threads/ Transmission of Mitutoyo Objectives .....	36
<b>Commentary:</b> Laser Operating Method and Precautions .....	37
<b>Glossary</b> .....	38

# Microscope unit for incorporating in Equipment VMU

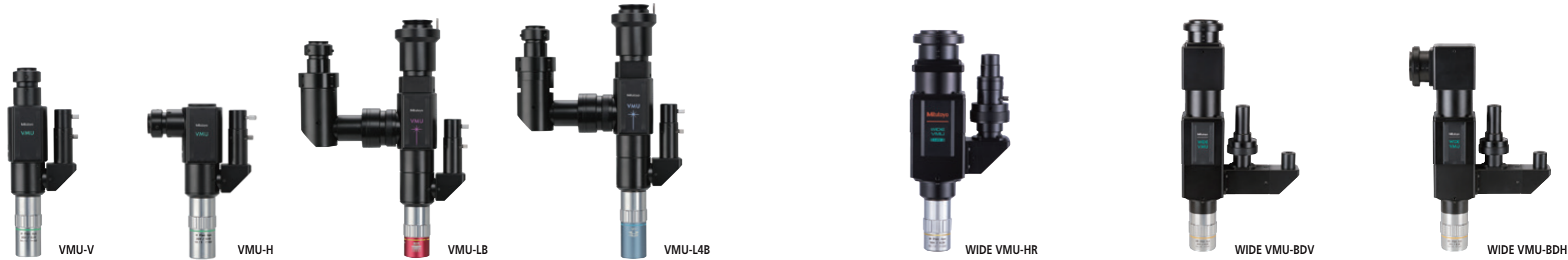

Objectives shown mounted on tubes are optional.

Objectives shown mounted on tubes are optional.

## Features

- > **Small, lightweight microscope unit** (Suitable for observing a wide range of objects: metal, resin, printed surfaces, minute mechanisms, etc.)
- > **Can used with YAG (near-infrared, visible, near-ultraviolet, or ultraviolet) lasers.**\*1 (Suitable for cutting, trimming, repair and marking of IC wiring (Au, Al), removing and processing thin-film (insulating film) and repair of color filters (defects repair).)
- > **Compatible with infrared optical systems**\*2
- > **Equipped as standard with a telecentric illumination system with aperture diaphragm for epi-illumination optical systems** (This is the best illumination system for image processing applications (e.g. dimension measurement, form inspection and positioning) which require even lighting.)
- > **Models with enhanced rigidity and performance (VMU-LB / VMU-L4B).**
- > **Custom-order is available to meet the customers' requirements** (Dual-camera, double magnification (high & low), etc.)

\*1: The performance and safety of laser-equipped system products is not guaranteed.

\*2: An infrared source and infrared camera are necessary. For more details on infrared observation, contact your local Mitutoyo sales office.

## Specifications

Model No.	VMU-V	VMU-H	VMU-LB	VMU-L4B
Order No.	378-505	378-506	378-513	378-514
Camera mounting orientation	Vertical	Horizontal	Vertical (rotatable)	
Observation	Bright-field/Erect image	Bright-field/Inverted image	Bright-field/Erect image	
Optical tube	Camera port	Magnification: 1X; Wavelength (λ): visible radiation		
	Mount	C-mount (centering and parfocal adjustment)		
	Tube lens (correction range)	Built in 1X (visible - NIR)	Built in 1X (NUV - visible - NIR)	Built in 1X (UV - visible - NIR)
	Laser port	—	Magnification: 1X λ: 355/532/1064 μm	Magnification: 1X λ: 226/355/532/1064 μm
Polarizer unit *1	Mount	With parfocal adjustment		
	Suitable YAG laser type *2	—	Fundamental, second and third-harmonic mode	Fundamental and second, third and fourth-harmonic mode
Suitable objective (optional)	For observation	M Plan Apo/HR/SL, G Plan Apo		
	For laser cutting	—	M/LCD Plan Apo NIR, M/LCD Plan Apo NUV Note: Selected depending on the wavelength of the laser source	M/LCD Plan Apo NIR, M/LCD Plan Apo NUV, M Plan UV Note: Selected depending on the wavelength of the laser source
Applicable camera	2/3 inch or smaller			
Optical system epi-illumination	Telecentric with aperture diaphragm			
Illuminated lens tube	Bright-field illuminated lens tube			
Illumination unit (optional)	Fiber illumination unit (LED) (No.176-386), Fiber-optic illumination unit (150 W) (176-316)			
Main unit mass	650 g	750 g	1270 g	1300 g

\*1: M Plan Apo 1X objective should be used together with a polarizer (378-710 or 378-715).

Note 1: Observe the following precautions when using VMU-LB or L4B with YAG laser source attached.

1. Be aware of the laser power and energy density. Otherwise, the optical system may be damaged.

2. Check the mass of the laser source. When mounting on a high-speed device or acceleration/deceleration device, please contact us.

Note 2: The design and manufacturing of the VMU series can be adapted to meet the customers' requirements: differential interference observation, dual camera setup (double magnification: high and low), etc.

## Features

- > **Observation over a wide field of view** (Image field of ø30 mm)
- > **Greatly enhanced brightness on the periphery of the field of view** (Reduces the dependence on the light distribution characteristics.)
- > **Compatible with infrared optical systems**\*1
- > **Small optical observation system** (Refer to page 35 for the dimensions.)
- > **Compatible with HR series of high resolving power lens** (Designed with pupil diameter of ø16.8)

\*1: An infrared source and infrared camera are necessary.

For more details on infrared observation, contact your local Mitutoyo sales office.

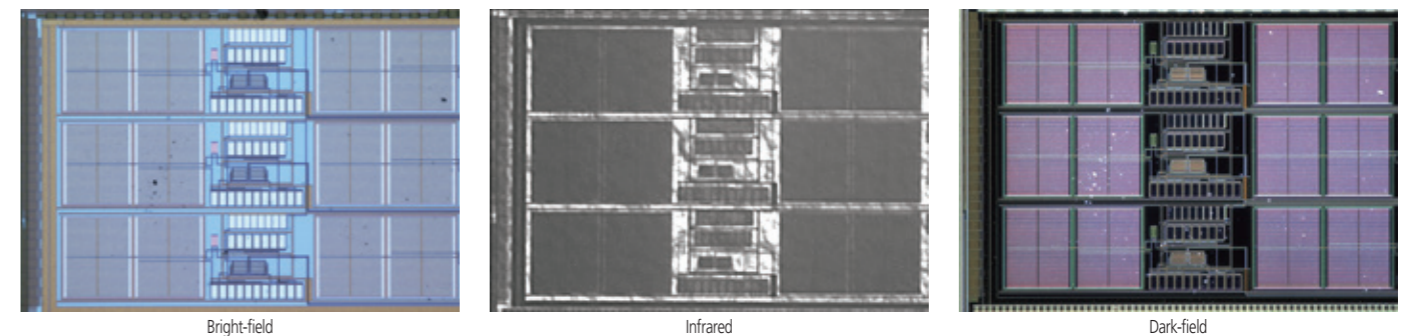

## Specifications

	For Bright-field Observation	For Bright/Dark-field Observation		
Model No.	WIDE VMU-HR	WIDE VMU-BDV	WIDE VMU-BDH	
Order No.	378-519	378-517	378-518	
Camera mounting orientation	Vertical	Vertical	Horizontal	
Observation	Bright-field/Erect image	Bright/Dark-field/Erect image	Bright/Dark-field/Inverted image	
Optical tube	Optical system	Magnification: 1X Visible light - Near-infrared light		
	Camera Mount	F-Mount, C-Mount (with aligning and parfocal adjustment mechanism)		
	Imaging forming (tube) lens	Built in 1X (visible - NIR)	Built in 1X (visible)	
	Image field	ø30 mm		
Polarized unit *1	Mountable			
Objective lens (required option)	M Plan Apo, M Plan Apo HR, M Plan Apo SL, G Plan Apo, NIR series		BD Plan Apo	
Applicable camera	Diagonal line length: 30 mm or less (equivalent to APS-C format)			
Optical system epi-illumination	Telecentric (Pupil diameter of ø16.8) *Coaxial epi-illumination, with aperture diaphragm	Telecentric illumination, Bright/Dark-field illumination optical tube (Dual-port fiber-optic illumination) Bright/Dark-field switching with light source on-off		
Illuminated lens tube	Bright-field illuminated lens tube (rotatable) *3, selectable between LED adapter and fiber adapter (both supplied as standard)		Bright-field illuminated lens tube (rotatable) *3	
Illumination unit (optional) *2	Fiber illumination unit (LED) (No.176-386), Fiber-optic illumination unit (150 W) (No. 176-316)			
Main unit mass	1400 g	2000 g	2150 g	

\*1: Polarized observation by Bright-field illumination \*2: Support for third-party LED illuminators (WIDE VMU-HR only) \*3: The fiber (light source) mount orientation can be changed.

# VMU

## System diagram

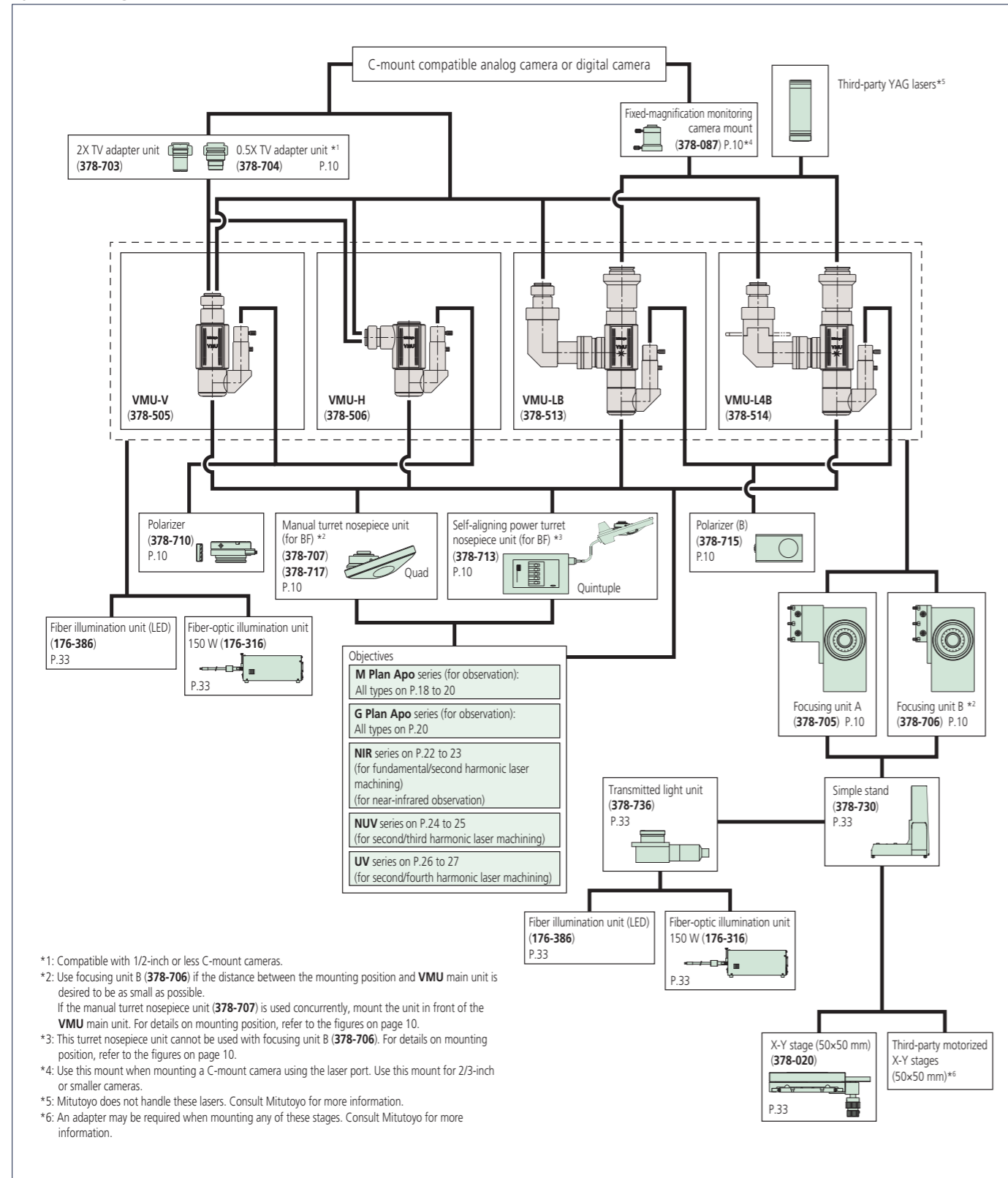

\*1: Compatible with 1/2-inch or less C-mount cameras.  
 \*2: Use focusing unit B (378-706) if the distance between the mounting position and VMU main unit is desired to be as small as possible.  
 If the manual turret nosepiece unit (378-707) is used concurrently, mount the unit in front of the VMU main unit. For details on mounting position, refer to the figures on page 10.  
 \*3: This turret nosepiece unit cannot be used with focusing unit B (378-706). For details on mounting position, refer to the figures on page 10.  
 \*4: Use this mount when mounting a C-mount camera using the laser port. Use this mount for 2/3-inch or smaller cameras.  
 \*5: Mitutoyo does not handle these lasers. Consult Mitutoyo for more information.  
 \*6: An adapter may be required when mounting any of these stages. Consult Mitutoyo for more information.

# WIDE VMU-HR / WIDE VMU-BD

## System diagram

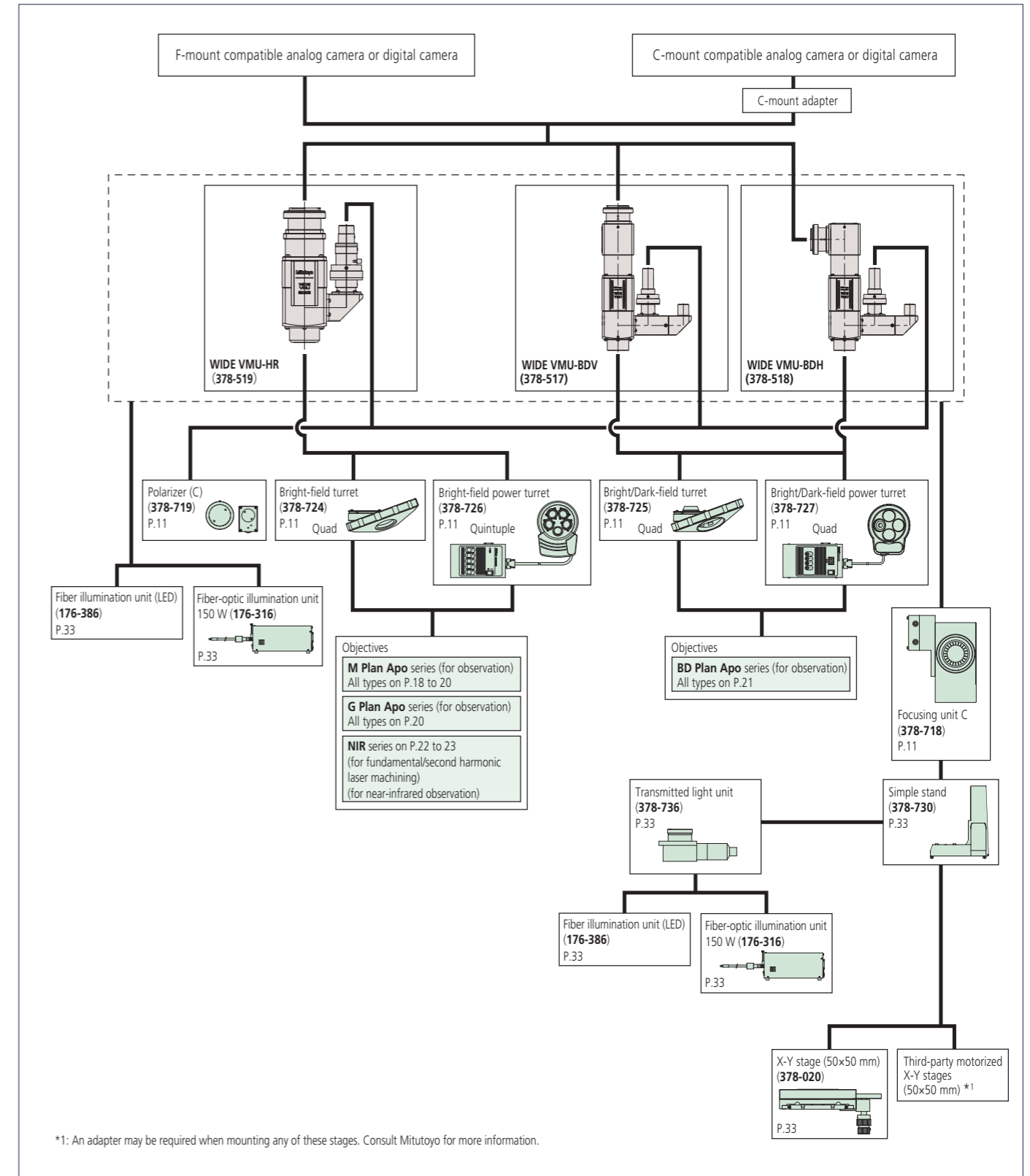

\*1: An adapter may be required when mounting any of these stages. Consult Mitutoyo for more information.

# Optional Accessories for VMU

## Manual turret

Has 4-objective mounts and can be fixed in the desired position relative (inward, outward, etc.) to the mounting surface.



Installed on 378-717 VMU-V with optional objectives

Order No.	378-707	378-717
Observation method	Bright-field	
No. of objective mounts	4 (Reference hole)	4 (1 reference hole and 3 holes with centering and parfocal adjustment)
Mass	780 g	990 g

## Focus unit A and B



Focus unit A mounted on VMU-V with an optional objective

Manual focus units for the VMU. An optional stand (378-730) and XY stage (378-020) are provided to be used in combination.

	Focus unit A	Focus unit B
Order No.	378-705	378-706
Travel range	50 mm	
Coarse/fine feed	Coarse: 3.8 mm/rev., Fine: 0.1 mm/rev.	
Loading capacity	Approx. 17.4 kg	Approx. 17.7 kg
Mass	2.9 kg	2.7 kg

## TV adapter unit

C-mount adapters for changing to a higher or lower magnification.



2X TV adapter unit



0.5X TV adapter unit

	2X TV adapter unit	0.5X TV adapter unit
Order No.	378-703	378-704
Magnification	2X	0.5X
Suitable camera	2/3 inch or smaller type	1/2 inch or smaller type
Mass	25 g	25 g

## Power turret

Has 5 objective mounts and can be fixed in the desired position relative (inward, outward, etc.) to the mounting surface.



Installed on WIDE VMU with optional objectives



Console box

Order No.	378-713
Observation method	Bright-field
No. of objective mounts	5 (1 reference hole and 4 holes with centering adjustment)
View field adjustment	±0.5 mm
Positioning accuracy	2σ = 3 μm
Durability (life-time)	1 million repositioning operations
Drive method	DC motor
Power supply	AC100 V - 240 V, 10 W
Output interface	RS-232C*1 for external PC control
Cable length	2.9 m*2 (connection of power turret and console box)
Dimensions (WxHxD) and mass	Turret: 130x47x186 mm, 1.8 kg, Console box: 108x63x176 mm, 810 g

\*1: Optional RS-232C Cable: 12AAA807

\*2: The length of cable connecting the power turret and console box is a safe maximum and therefore Mitutoyo does not guarantee error-free operation if a cable extension is used to increase total cable length.

## Polarizer and Analyzer

Provides simplified polarized light observation. Also enhances contrast of low-magnification objectives.



No. 378-710



No. 378-715



Installed on VMU-L4B

Order No.	378-710	VMU-V • VMU-H
Order No.	378-715	VMU-LB • VMU-L4B

## Camera mount



378-087 Mass: 180 g

Can be attached to the laser mount (VMU-LB and VMU-L4B) for dual-camera system. It is compatible with 2/3 inch or smaller C-mount cameras.

# Optional Accessories for WIDE VMU-HR / WIDE VMU-BD

## Bright-field turret

### Bright/Dark-field turret

Has 4-objective mounts and can be fixed in the desired position relative (inward, outward, etc.) to the mounting surface.



No. 378-724

No. 378-725

Installed on 378-724 WIDE VMU-HR with optional objectives

Order No.	378-724	378-725
Observation method	Bright-field	Bright/Dark-field
No. of objective mounts	4 (Reference hole)	4 (Reference hole)
Mass	825 g	755 g
Applicable models	WIDE VMU-HR	WIDE VMU-BDV WIDE VMU-BDH

## Focus unit C



Focus unit C mounted on WIDE VMU-HR with an optional objective

Manual focus units for the WIDE VMU. When an optional stand (378-730) is mounted, center of stage and optical axis are matched.

	Focus unit C
Order No.	378-718
Travel range	50 mm
Coarse/fine feed	Coarse: 3.8 mm/rev., Fine: 0.1 mm/rev.
Loading capacity	Approx. 17.4 kg
Mass	2.7 kg
Applicable models	WIDE VMU (all models)

## Bright-field power turret

### Bright/Dark-field power turret

Has 5-objective mounts for Bright-field power turret and 4-objective mounts for Bright/Dark-field power turret. It can be fixed in the desired position relative (inward, outward, etc.) to the mounting surface.



No. 378-726



No. 378-727

Installed on No. 378-726 WIDE VMU-HR with optional objectives

Order No.	378-726	378-727
Observation method	Bright-field	Bright/Dark-field
No. of objective mounts	5 (1 reference hole and 4 holes with centering adjustment)	4 (Reference hole)
View field adjustment	±0.5 mm	-
Positioning accuracy	2σ = 3 μm	-
Durability (life-time)	1 million repositioning operations	-
Drive method	DC motor	-
Power supply	AC100 V - 240 V Max. power consumption is approx. 10 W	AC100 V - 240 V Max. power consumption is approx. 6 W
Output interface	RS-232C*1 for external PC control	
Cable length	2.9 m*2 (connection of power turret and console box)	
Dimension: WxHxD (mm)	Turret: 130x47x186 mm, 1.8 kg, Console box: 108x63x176 mm, 810 g	Turret: 164x65x137 mm, 1.8 kg, Console box: 108x72x193 mm, 810 g
Mass		
Applicable models	WIDE VMU-HR	WIDE VMU-BDV WIDE VMU-BDH

\*1: Optional RS-232C Cable: 12AAA807

\*2: The length of cable connecting the power turret and console box is a safe maximum and therefore Mitutoyo does not guarantee error-free operation if a cable extension is used to increase total cable length.

## Polarizer and Analyzer (C)

Provides simplified polarized light observation. Also enhances contrast of low-magnification objectives.



No. 378-719

Order No.	378-719	WIDE VMU (all models)
-----------	---------	-----------------------

# Dimensions of Optional Accessories for VMU

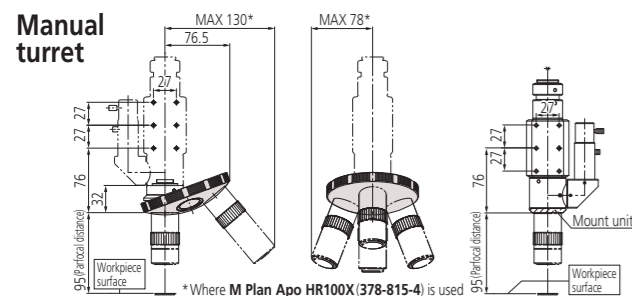

When mounting the turret on **VMU-V** or **VMU-H**  
 Note 1: The lens mount must be removed from VMU.  
 Note 2: The orientation of the revolver can be freely set to the mounting surface.

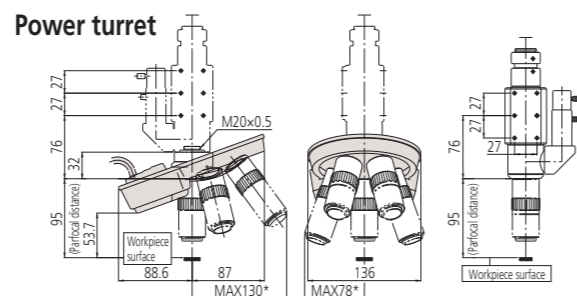

When mounting the turret on **VMU-V** or **VMU-H**  
 Note 1: The lens mount must be removed from VMU.  
 Note 2: The orientation of the revolver can be freely set to the mounting surface.

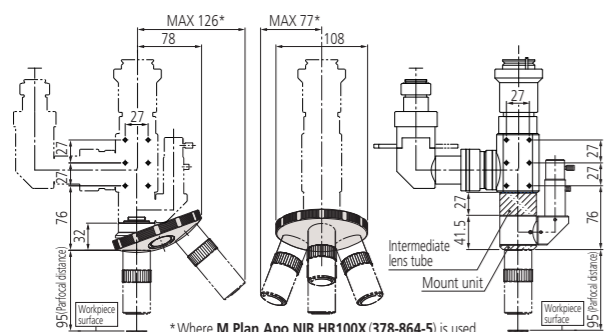

When mounting the turret on **VMU-LB** or **VMU-L4B**  
 Note 1: The middle optical tube and lens mount must be removed from VMU.  
 Note 2: The orientation of the revolver can be freely set to the mounting surface.

## Focus unit A and B

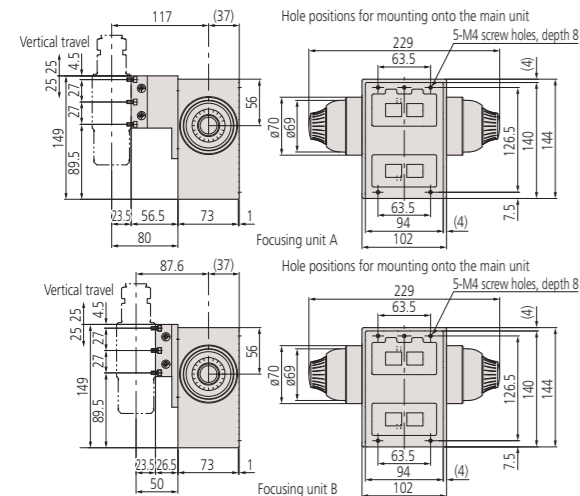

## TV adapter unit

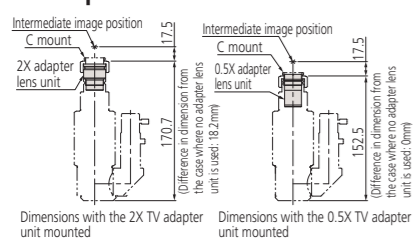

## Camera mount

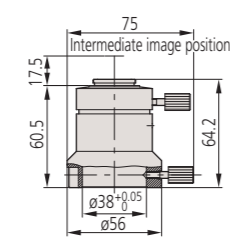

## Polarizer and Analyzer

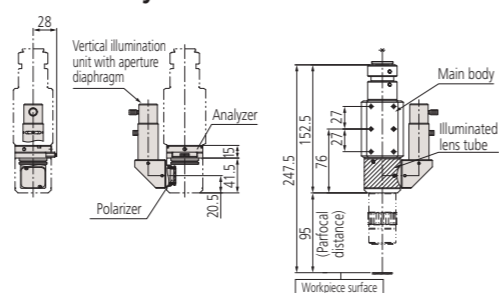

Installing the polarizer and analyzer on **VMU-V** or **VMU-H**  
 Note: The analyzer is installed by removing the illuminated lens tube.  
 The polarizer is installed by removing the vertical illumination unit with aperture diaphragm.

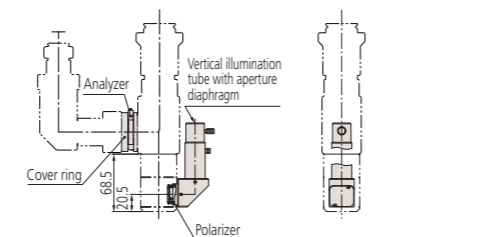

When installing the polarizer on **VMU-LB** or **VMU-L4B**  
 Note: The analyzer is installed by loosening the cover ring.  
 The polarizer is installed by removing the vertical illumination unit with aperture diaphragm.

# Dimensions of Optional Accessories for WIDE VMU-HR / WIDE VMU-BD

## Bright-field turret

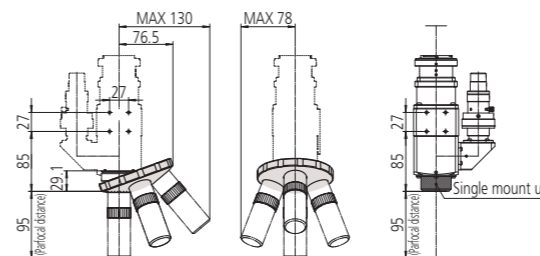

When mounting the turret on **WIDE VMU-HR**  
 Note 1: Turret is installed by removing the single mount unit, but the distance between the mounting position of WIDE VMU main unit and the stage is unchanged.  
 Note 2: Turret mounting direction is limited to the direction indicated in the above figure.

## Bright-field power turret

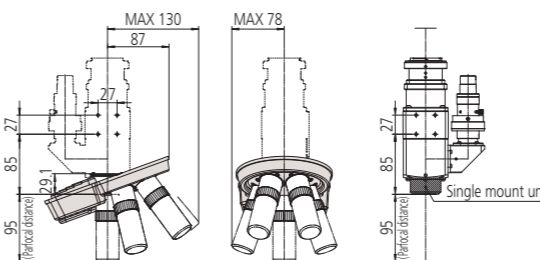

When mounting the turret on **WIDE VMU-HR**  
 Note 1: Turret is installed by removing the single mount unit, but the distance between the mounting position of WIDE VMU main unit and the stage is unchanged.  
 Note 2: Turret mounting direction is limited to the direction indicated in the above figure.

## Focus unit C

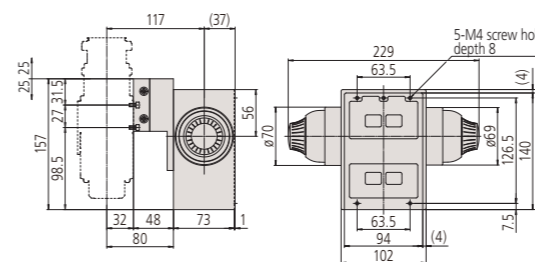

## Bright/Dark-field turret

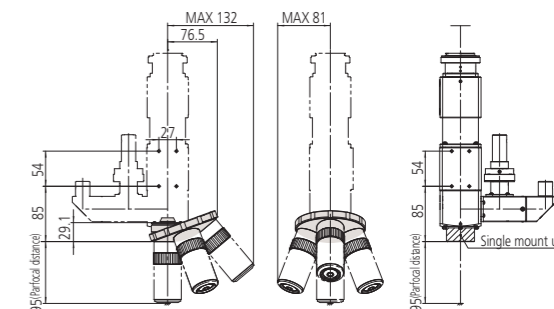

When mounting the turret on **WIDE VMU-BDV / BDH**  
 Note 1: Turret is installed by removing the single mount unit, but the distance between the mounting position of WIDE VMU main unit and the stage is unchanged.  
 Note 2: Turret mounting direction is limited to the direction indicated in the above figure.

## Bright/Dark-field power turret

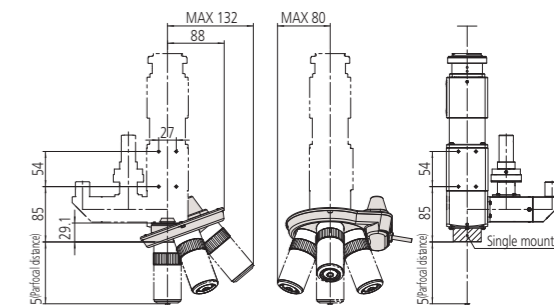

When mounting the turret on **WIDE VMU-BDV / BDH**  
 Note 1: Turret is installed by removing the single mount unit, but the distance between the mounting position of WIDE VMU main unit and the stage is unchanged.  
 Note 2: Turret mounting direction is limited to the direction indicated in the above figure.

## Polarizer and Analyzer (C)

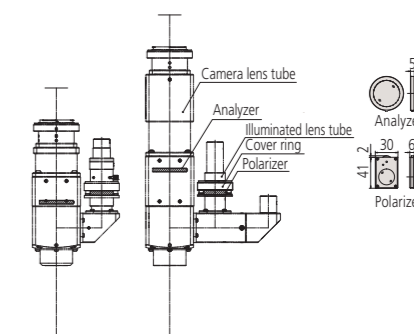

Note: The polarizer is installed by loosening the cover ring.  
 The analyzer is installed by removing the camera lens tube.

# Microscope unit FS70



FS70Z



FS70L4

Objectives and eyepieces shown mounted are optional.

## Features

### > Compact microscope unit with trinocular eyepiece tube

(Suitable for observation of many different types of object: metal surfaces, semiconductors, LCDs, resins, etc.)

### > Can used with YAG (near-infrared, visible, near-ultraviolet, or ultraviolet) lasers.\*1

(Suitable for cutting, trimming, repair and marking of IC wiring (Au, Al), removing and processing thin-films (insulating film) and repair of color filters.)

### > Compatible with infrared optical systems\*2

### > Product range supporting various observation methods

(Bright-field/Dark-field/Simple polarization/Differential interference contrast (DIC))

### > Equipped as standard with a Koehler illumination with aperture diaphragm for epi-illumination optical systems

### > High operability with microscopes

(Inward turret design and long-working-distance objectives)

\*1: The performance and safety of laser-equipped system products is not guaranteed.

\*2: An infrared source and infrared camera are necessary. For more details on infrared observation, contact your local Mitutoyo sales office.

## Specifications

Standard head type	Model No.	FS70	—	FS70Z	—	FS70ZD	FS70L	FS70L4
Order No.		378-184-1	—	378-185-1	—	Made-to-order	378-186-1	378-187-1
Tilting head type	Model No.	—	FS70-TH	—	FS70Z-TH	FS70ZD-TH	FS70L-TH	FS70L4-TH
Order No.		—	378-184-3	—	378-185-3	Made-to-order	378-186-3	378-187-3
Focus adjustment	50 mm travel range with concentric coarse (3.8 mm/rev) and fine (0.1 mm/rev) focusing wheels (right / left)							
Observation image	Erect image							
	BF (Bright-field)	✓	✓	✓	✓	✓	✓	✓
	BD (Bright-field/Dark-field)	✓	✓	✓	✓	✓	✓	✓
	Polarization	✓	✓	✓	✓	✓	✓	✓
	Differential interference contrast (DIC)	✓	✓	✓	✓	✓	✓	✓
Optical tube type	Siedentopf, adjustable interpupillary distance range: 51 - 76 mm							
Field number	24 mm							
Tilt angle	0 to 20°, displacement of eye point: 114 mm (only for tilting head type)							
Optical pass ratio	Fixed type (Eyepiece/TV = 50/50)	Switchable type (Eyepiece/Tube = 100/0: 0/100)	Fixed type (Eyepiece/Tube = 50/50)	Switchable type (Eyepiece/Tube = 100/0: 0/100)	Fixed type*3 (Eyepiece/TV = 50/50)	Switchable type (Eyepiece/Tube = 100/0: 0/100)		
Protective filter	1X				1X - 2X zoom		Built-in laser beam filter	
Tube lens	1X				1X - 2X zoom		1X	
Applicable laser	—				1064/532/355 nm		532/266 nm	
Camera mount	C-mount (using optional adapter B*1)				Use a laser with TV port.		C-mount receptacle (with green filter switch)	
Optical system epi-illumination	Epi-illumination for Bright-field (Koehler illumination, with aperture diaphragm)							
Illumination unit (optional)	Fiber illumination unit (LED) (No.176-386), Fiber-optic illumination unit (150 W) (176-316) stepless adjustment, light guide length: 1.5 m							
Objective, optional (for observation)	M Plan Apo/HR/SL, G Plan Apo				BD Plan Apo		M Plan Apo/HR/SL, G Plan Apo	
Objective, optional (for laser-cutting)	—				NIR Series NUV Series		UV Series	
Loading*2	14.5 kg	13.6 kg	14.1 kg	13.2 kg	14.1 kg (tilting head type: 13.2 kg)	14.2 kg (tilting head type: 13.5 kg)	13.9 kg (tilting head type: 13.1 kg)	
Mass (main unit)	6.1 kg	7.1 kg	6.6 kg	7.5 kg	6.6 kg (tilting head type: 7.5 kg)	6.4 kg (tilting head type: 7.2 kg)	6.7 kg (tilting head type: 7.5 kg)	

\*1: Installation is optional. \*2: Loading on optical tube excluding weight of objective lenses and eyepieces

\*3: It is a switchable type when using FS70ZD-TH (Tilting head type).

Note: Observe the following precautions when using FS70L or FS70L4 with YAG laser source attached.

- Be aware of the laser power and energy density limitations of the optical system to avoid damaged.

- Check the mass of the laser source. When mounting on a high-speed device or acceleration/deceleration device, please contact us.

Bulb replacement	Standard: Halogen bulb (12 V, 100 W) (517181)
	For the fiber-optic cable illumination unit (12 V, 100 W) (378-700)

## System diagram

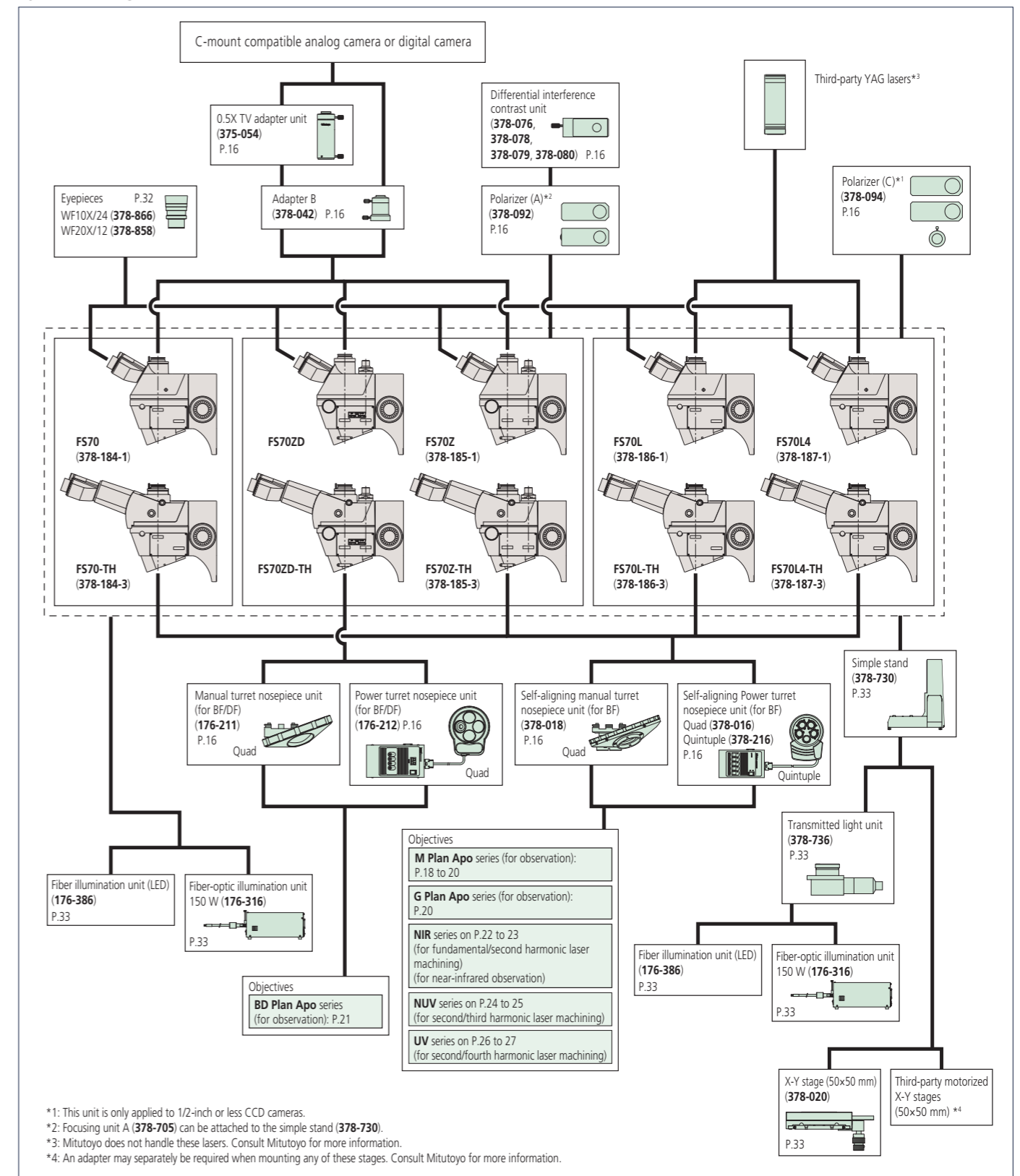

\*1: This unit is only applied to 1/2-inch or less CCD cameras.

\*2: Focusing unit A (378-705) can be attached to the simple stand (378-730).

\*3: Mitutoyo does not handle these lasers. Consult Mitutoyo for more information.

\*4: An adapter may separately be required when mounting any of these stages. Consult Mitutoyo for more information.



# Optional Accessories for FS70

## Manual turret



Order No.	378-018	378-211
Observation method	Bright-field	Bright/Dark-field
No. of objective mounts	4 (1 reference hole and 3 holes with centering and parfocal adjustment)	4
View field adjustment	±0.5 mm	—
Parfocal adjustment	±0.5 mm	—
Mass	980 g	1.2 kg

## Polarizer and analyzer

For simplified polarized-light observation. Also suitable for enhancing contrast of low-magnification objectives.



For FS70Z  
378-092



For FS70L • FS70L4  
378-094

## DIC unit

Used for differential interference contrast observation in conjunction with the polarizer.



Order No.	Magnification
378-076	100X, SL80X, SL50X
378-078	50X, SL20X
378-079	20X
378-080	10X, 5X

## Adapter B

Used for mounting a C-mount camera.

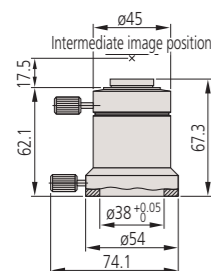

378-042  
View field of image: ø11 mm  
Mass: 170 g

## 0.5X TV adapter unit

Allows observation over a wide field of view on the monitor (2X wide) due to the 0.5X relay optics. It is used in conjunction with the optional adapter B. A C-mount is included.

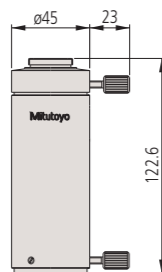

375-054  
View field of image: ø11 mm  
Mass: 300 g

## Power turret



Order No.	378-216	378-016	176-212
Observation method	Bright-field		Bright/Dark-field
No. of objective mounts	5 (1 reference hole and 4 holes with centering adjustment)	4 (1 reference hole and 3 holes with centering adjustment)	4
View field adjustment	±0.5 mm		—
Positioning accuracy	2 σ = 3 μm	—	—
Durability (life-time)	1 million repositioning operations	—	—
Drive method	DC motor		
Power supply	AC100 V - 240 V, 10 W	AC100 V - 240 V, 6 W	
Output interface	RS-232C*1 for external PC control		
Cable length	2.9 m*2 (connection of power turret and console box)		
Dimensions (WxHxD) and mass	Turret: 164x65x137 mm, 1.4 kg (378-216: 130x47x186 mm, 1.7 kg) Console box: 108x72x193 mm, 810 g (378-216: 108x63x176 mm, 810 g)		

\*1: Optional RS-232C Cable: 12AAA807

\*2: The length of cable connecting the power turret and console box is a safe maximum and therefore Mitutoyo does not guarantee error-free operation if a cable extension is used to increase total cable length.

# Dimensions of Optional Accessories for FS70

## Manual turret

378-018

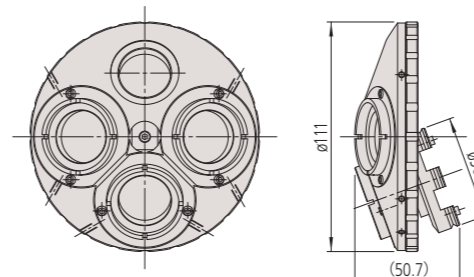

176-211

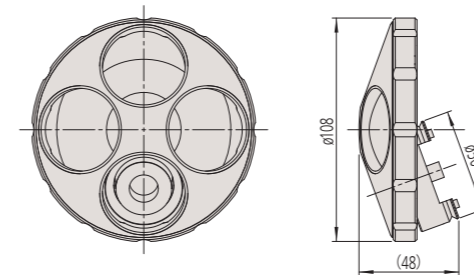

## Optional objective adapter: 378-026-1

This objective adapter allows mounting the bright-field objective on the bright/dark-field turret (176-211 and 176-210) while maintaining the focus position (parfocal).

Order No.	378-026-1
Applicable models	Microscopes mounted with the bright/dark-field manual turret or power turret (MF-U, HyperMF-U)
Applicable objective lens	M Plan Apo, M Plan Apo SL, G Plan Apo, M Plan Apo NIR, M Plan Apo NUV, M Plan UV

## Tilting head type

Mitutoyo's FS70-series lineup adopts a tilting head specification that allows the user to adjust the head to an appropriate eye point according to personal physical attributes when looking through the microscope eyepiece.

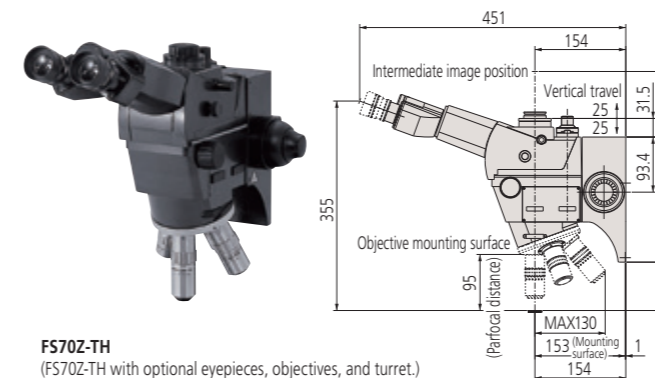

FS70Z-TH  
(FS70Z-TH with optional eyepieces, objectives, and turret.)

## Power turret

378-216

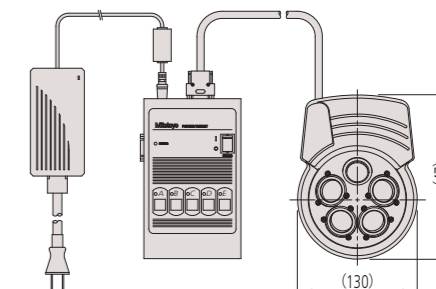

176-212/378-016

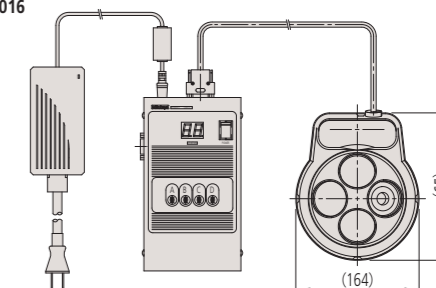

## Focus point adjust shim set

Order No.	Use	Details
378-089	For bright-field turret	The focus point adjust shim set includes 50 μm, 30 μm and 20 μm thickness SUS rings
378-090	For bright/dark-field turret	

## Short focus unit type

Manual Focus Unit S can be mounted on the main unit 68mm higher than the standard focus unit without changing the eye-point position. The order numbers in the following table represent the FS70-series main units on which this focus unit has previously been mounted.

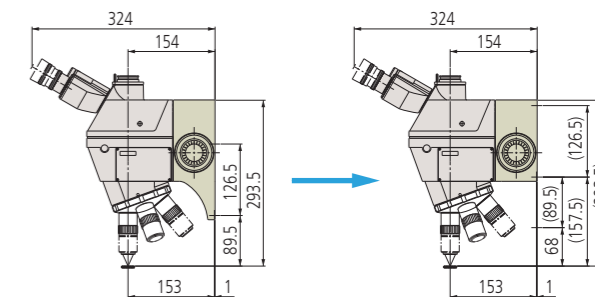

Standard focusing unit mounting dimensions Manual focusing unit S mounting dimensions

Model	FS70-S	FS70Z-S	FS70L-S	FS70L4-S
Order No.	378-184-2	378-185-2	378-186-2	378-187-2
Travel range	50 mm			
Coarse/fine feed	Coarse feed: 3.8 mm/rev., Fine feed: 0.1 mm/rev.			
Loading capacity of camera mount*	14.5 kg	14.1 kg	14.2 kg	13.9 kg
Mass	6.1 kg	6.6 kg	6.4 kg	6.7 kg

\*Mass of turret, objective, and eyepiece are excluded.  
Note: If the tilting head type with a short focus unit is required, please contact your local Mitutoyo sales office.

Objectives for Bright-field Observation  
(long working distance)

M Plan Apo /  
M Plan Apo HR

VMU WIDE VMU FS70 MF-U Hyper MF-U



- Features
- > Bright-field observation
  - > Wavelength compensation range 436 nm to 656 nm (Designed to fundamental wavelength 587 nm)
  - > Infinity corrected
  - > Long working distance
  - > Plan-Apochromat
  - > High-resolving power type (M Plan Apo HR)

Dimensions

M Plan Apo 1X

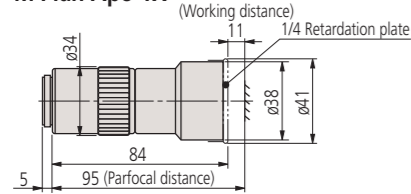

M Plan Apo 10X

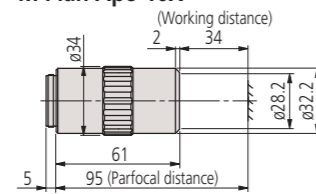

M Plan Apo HR 5X

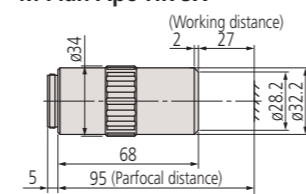

M Plan Apo 2X

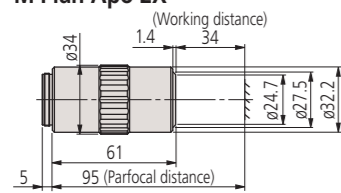

M Plan Apo 20X

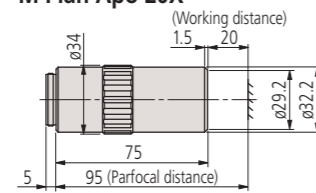

M Plan Apo HR 10X

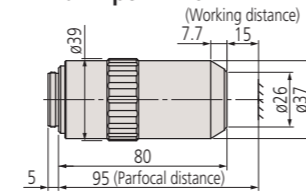

M Plan Apo 5X

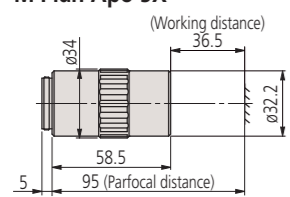

M Plan Apo 50X  
(特許登録済)

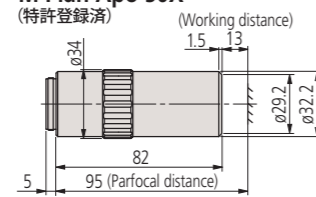

M Plan Apo HR 50X

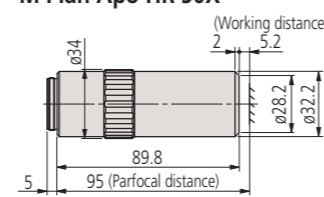

M Plan Apo 7.5X

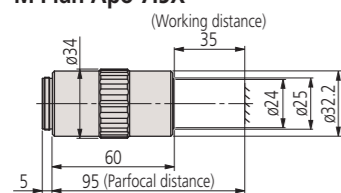

M Plan Apo 100X

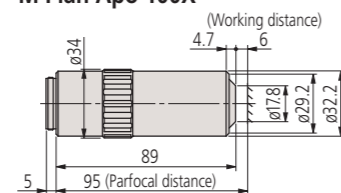

M Plan Apo HR 100X

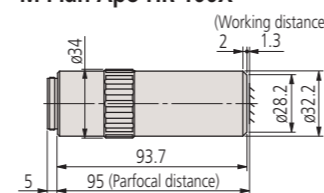

Specifications

Model	Order No.	N.A.	W.D. (mm)	f (mm) (λ=550 nm)	R (μm) (λ=550 nm)	±DOF (μm)	Real FOV (mm)		Mass (g)
							ø24 eyepiece	1/2 inch camera	
<b>M Plan Apo</b>									
M Plan Apo 1X *1	378-800-12	0.025	11.0	200	11.0	440	24	4.8×6.4	300
M Plan Apo 2X *2	378-801-12	0.055	34.0	100	5.0	91	12	2.4×3.2	220
M Plan Apo 5X	378-802-12	0.14	36.5	40	2.0	14	4.8	0.96×1.28	262
M Plan Apo 7.5X	378-807-3	0.21	35.0	26.67	1.3	6.2	3.2	0.64×0.85	240
M Plan Apo 10X	378-803-3	0.28	34.0	20	1.0	3.5	2.4	0.48×0.64	240
M Plan Apo 20X	378-804-3	0.42	20.0	10	0.7	1.6	1.2	0.24×0.32	270
M Plan Apo 50X	378-805-3	0.55	13.0	4	0.5	0.9	0.48	0.10×0.13	290
M Plan Apo 100X	378-806-3	0.70	6.0	2	0.4	0.6	0.24	0.05×0.06	320
<b>M Plan Apo HR</b>									
M Plan Apo HR 5X *3	378-787-16	0.21	27.0	40	1.3	6.2	4.8	0.96×1.28	285
M Plan Apo HR 10X *3	378-788-15	0.42	15.0	20	0.7	1.60	2.4	0.48×0.64	455
M Plan Apo HR 50X	378-814-4	0.75	5.2	4	0.4	0.49	0.48	0.10×0.13	400
M Plan Apo HR 100X	378-815-4	0.90	1.3	2	0.3	0.34	0.24	0.05×0.06	410

• Every resolution and single objective's depth of focus in the above table is a value determined on the basis of a reference wavelength (λ=0.55 μm).

\*1: When observing a workpiece whose optical reflectance is low, an appropriate polarizer should be used with this lens.

\*2: When observing a workpiece whose optical reflectance is low, using this lens with a 1/4 wave plate and polarization unit (No.02ALN370) is recommended.

\*3: These specifications apply to the objectives in isolation and may not apply when a lens is mounted in the turret of a microscope, depending on the design of that microscope. In the case where the vertical epi-illumination is provided by the user it is important to balance the various optical parameters so that optimum illumination of the target surface is obtained. Contact your local Mitutoyo sales Office for information on how this may be achieved.

Made-to-order

## Objectives for Bright-field Observation (Super-long working distance)

### M Plan Apo SL

VMU WIDE VMU FS70 MF-U Hyper MF-U

- Features**
- > Bright-field observation
  - > Wavelength compensation range 436 nm to 656 nm (Designed to fundamental wavelength 587 nm)
  - > Infinity corrected
  - > Super long working distance
  - > Plan-Apochromat

#### Dimensions

M Plan Apo SL20X

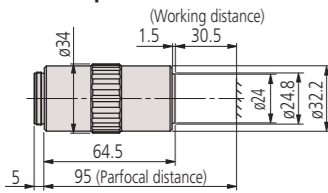

M Plan Apo SL50X

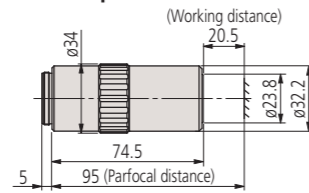

M Plan Apo SL100X

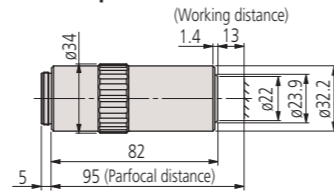

#### Specifications

Model	Order No.	N.A.	W.D. (mm)	f (mm) (λ=550 nm)	R (μm) (λ=550 nm)	±DOF (μm)	Real FOV (mm)		Mass (g)
							ø24 eyepiece	1/2 inch camera	
<b>M Plan Apo SL</b>									
M Plan Apo SL20X	378-810-3	0.28	30.5	10	1.0	3.5	1.2	0.24x0.32	240
M Plan Apo SL50X	378-811-15	0.42	20.5	4	0.7	1.6	0.48	0.10x0.13	280
M Plan Apo SL100X	378-813-3	0.55	13.0	2	0.5	0.9	0.24	0.05x0.06	290

\* Every resolution and single objective's depth of focus in the above table is a value determined on the basis of a reference wavelength (λ=0.55 μm).

## Objectives for Bright-field Observation (with cover-glass thickness compensation)

### G Plan Apo

VMU WIDE VMU FS70 MF-U Hyper MF-U

- Features**
- > Bright-field observation
  - > Wavelength compensation range 436 nm to 656 nm (Design to fundamental wavelength 587 nm)
  - > Infinity corrected
  - > Long working distance
  - > Plan-Apochromat
  - > Design enables observation through a 3.5 mm cover glass (material: BK7).

Note: Mitutoyo is ready to design and manufacture a specific sheet of glass according to a specified glass thickness, material or refractive index, please contact your local Mitutoyo sales office.

#### Dimensions

G Plan Apo 20X

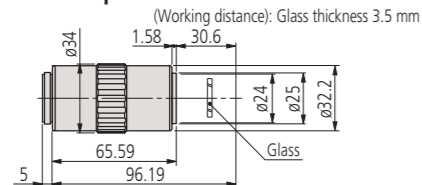

G Plan Apo 50X

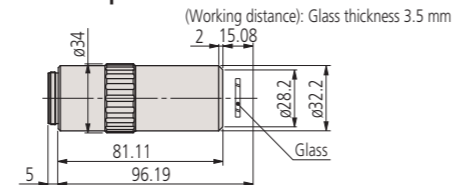

#### Specifications

Model	Order No.	N.A.	W.D. (mm)	f (mm) (λ=550 nm)	R (μm) (λ=550 nm)	±DOF (μm)	Real FOV (mm)		Mass (g)
							ø24 eyepiece	1/2 inch camera	
<b>G Plan Apo</b>									
G Plan Apo 20X (t3.5)	378-847	0.28	29.42*	10	1.0	3.5	1.2	0.24x0.32	270
G Plan Apo 50X (t3.5)	378-848-3	0.50	13.89*	4	0.6	1.1	0.48	0.10x0.13	320

\* Every resolution and single objective's depth of focus in the above table is a value determined on the basis of a reference wavelength (λ=0.55 μm).

\* In air

## Objectives for Bright/Dark-field Observation (long working distance)

### BD Plan Apo

WIDE VMU FS70 MF-U Hyper MF-U

- Features**
- > Bright/dark-field observation
  - > Wavelength compensation range 436 nm to 656 nm (Designed to fundamental wavelength 587 nm)
  - > Infinity corrected
  - > Long working distance
  - > Plan-Apochromat



#### Dimensions

BD Plan Apo 2X

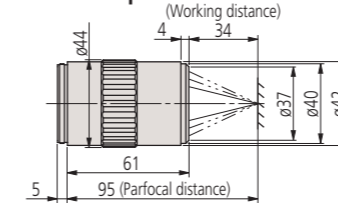

BD Plan Apo 10X

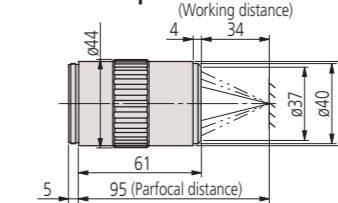

BD Plan Apo 100X

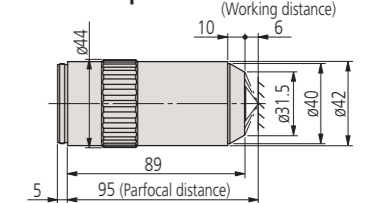

BD Plan Apo 5X

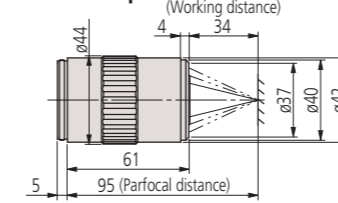

BD Plan Apo 20X

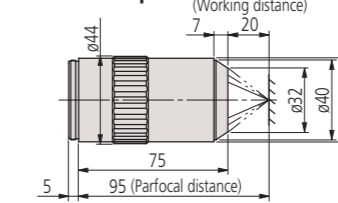

BD Plan Apo 7.5X

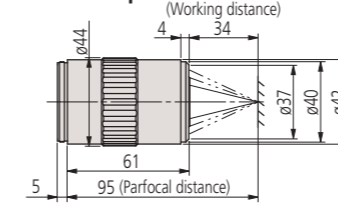

BD Plan Apo 50X

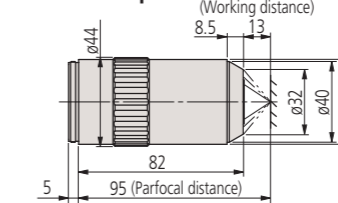

#### Specifications

Model	Order No.	N.A.	W.D. (mm)	f (mm) (λ=550 nm)	R (μm) (λ=550 nm)	±DOF (μm)	Real FOV (mm)		Mass (g)
							ø24 eyepiece	1/2 inch camera	
<b>BD Plan Apo</b>									
BD Plan Apo 2X*	378-831-12	0.055	34.0	100	5.0	91	12	2.4x3.2	340
BD Plan Apo 5X	378-832-12	0.14	34.0	40	2.0	14	4.8	0.96x1.28	382
BD Plan Apo 7.5X	378-830-7	0.21	34.0	26.67	1.3	6.2	3.2	0.64x0.85	350
BD Plan Apo 10X	378-833-7	0.28	34.0	20	1.0	3.5	2.4	0.48x0.64	350
BD Plan Apo 20X	378-834-7	0.42	20.0	10	0.7	1.6	1.2	0.24x0.32	400
BD Plan Apo 50X	378-835-7	0.55	13.0	4	0.5	0.9	0.48	0.10x0.13	440
BD Plan Apo 100X	378-836-7	0.70	6.0	2	0.4	0.6	0.24	0.05x0.06	460

\* Every resolution and single objective's depth of focus in the above table is a value determined on the basis of a reference wavelength (λ=0.55 μm).

\* It is recommended to be used together with the 1/4 wavelength plate B (02ALN380) and appropriate polarizer for the microscope used (Working distance will be shortened 4 mm).

Near-infrared radiation range objectives for Bright-field observation

M Plan Apo NIR /  
M Plan Apo NIR HR /  
M Plan Apo NIR B

VMU WIDE VMU FS70

- Features
- > Bright-field observation/Near-infrared observation/Laser machining
  - > Wavelength compensation range 480 nm to 1800 nm (M Plan Apo NIR B: 420 nm to 1064 nm)
  - > Infinity corrected
  - > Long working distance
  - > Plan-Apochromat
  - > High-resolving power typ (M Plan Apo NIR HR)
  - > Ultra-long working distance and High spectral transmission factor (M Plan Apo NIR B)



Dimensions

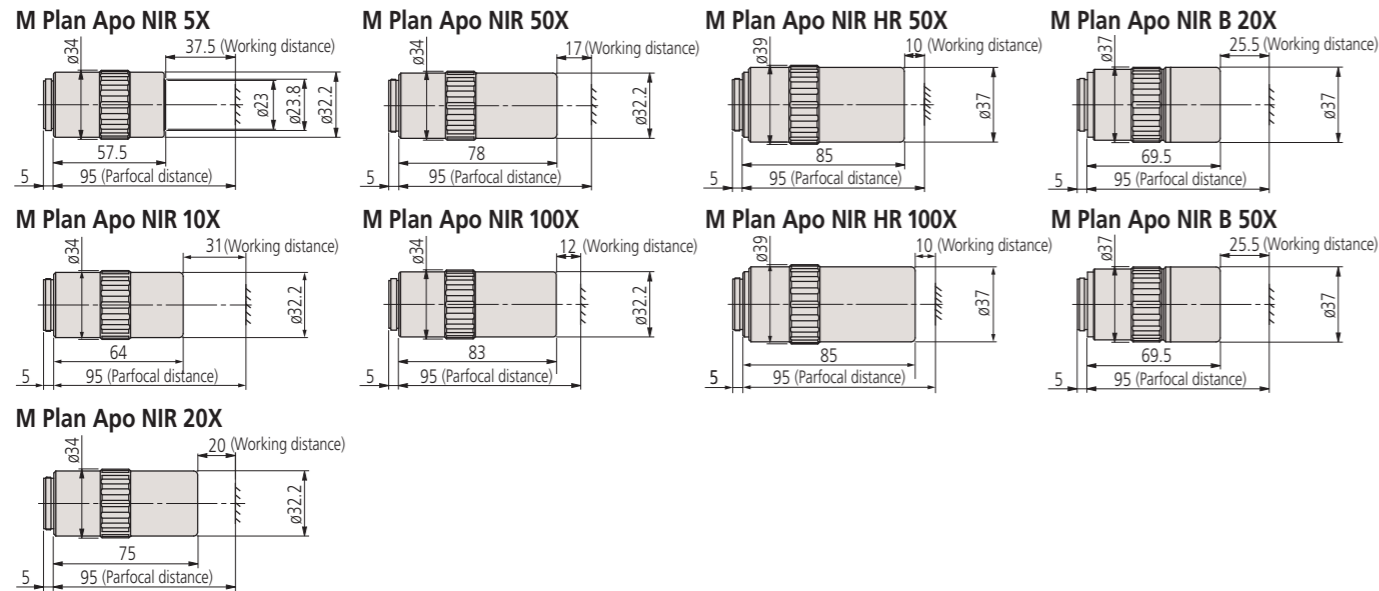

Specifications

Model	Order No.	N.A.	W.D. (mm)	f (mm) (λ=550 nm)	R (μm) (λ=550 nm)	±DOF (μm)	Real FOV (mm)		Mass (g)
							ø24 eyepiece	1/2 inch camera	
<b>M Plan Apo NIR</b>									
M Plan Apo NIR 5X	378-822-5	0.14	37.5	40	2.0	14.0	4.8	0.96x1.28	220
M Plan Apo NIR 10X	378-823-15	0.26	31.0	20	1.1	4.1	2.4	0.48x0.64	250
M Plan Apo NIR 20X	378-824-16	0.40	20.0	10	0.7	1.7	1.2	0.24x0.32	300
M Plan Apo NIR 50X	378-825-17	0.42	17.0	4	0.7	1.6	0.48	0.10x0.13	350
M Plan Apo NIR 100X	378-826-15	0.50	12.0	2	0.6	1.1	0.24	0.05x0.06	335
<b>M Plan Apo NIR HR</b>									
M Plan Apo NIR HR 50X	378-863-5	0.65	10.0	4	0.4	0.7	0.48	0.10x0.13	450
M Plan Apo NIR HR 100X	378-864-15	0.70	10.0	2	0.4	0.6	0.24	0.05x0.06	490
<b>M Plan Apo NIR B</b>									
M Plan Apo NIR B 20X	378-867-5	0.40	25.5	10	0.7	1.7	1.2	0.24x0.13	350
M Plan Apo NIR B 50X	378-868-5	0.42	25.5	4	0.7	1.6	0.48	0.10x0.13	375

\* Every resolution and single objective's depth of focus in the above table is a value determined on the basis of a reference wavelength (λ=0.55 μm).  
Note: If the wavelength used is 1100 nm or longer, the focal point may deviate slightly from that in visible radiation.

Near-infrared radiation range objectives for Bright-field observation (with cover-glass thickness compensation)

LCD Plan Apo NIR /  
LCD Plan Apo NIR HR

VMU WIDE VMU FS70

- Features
- > Bright-field observation/Near-infrared observation/Laser machining
  - > Wavelength compensation range 480 nm to 1800 nm
  - > Infinity corrected
  - > Long working distance
  - > Plan-Apochromat
  - > Design enables observation through a 3.5 mm or 1.1 mm cover glass (material: BK7).
- Note: Mitutoyo is ready to design and manufacture a specific sheet of glass according to a specified glass thickness, material or refractive index, please contact your local Mitutoyo sales office.
- > High-resolving power typ (LCD Plan Apo NIR HR)



Dimensions

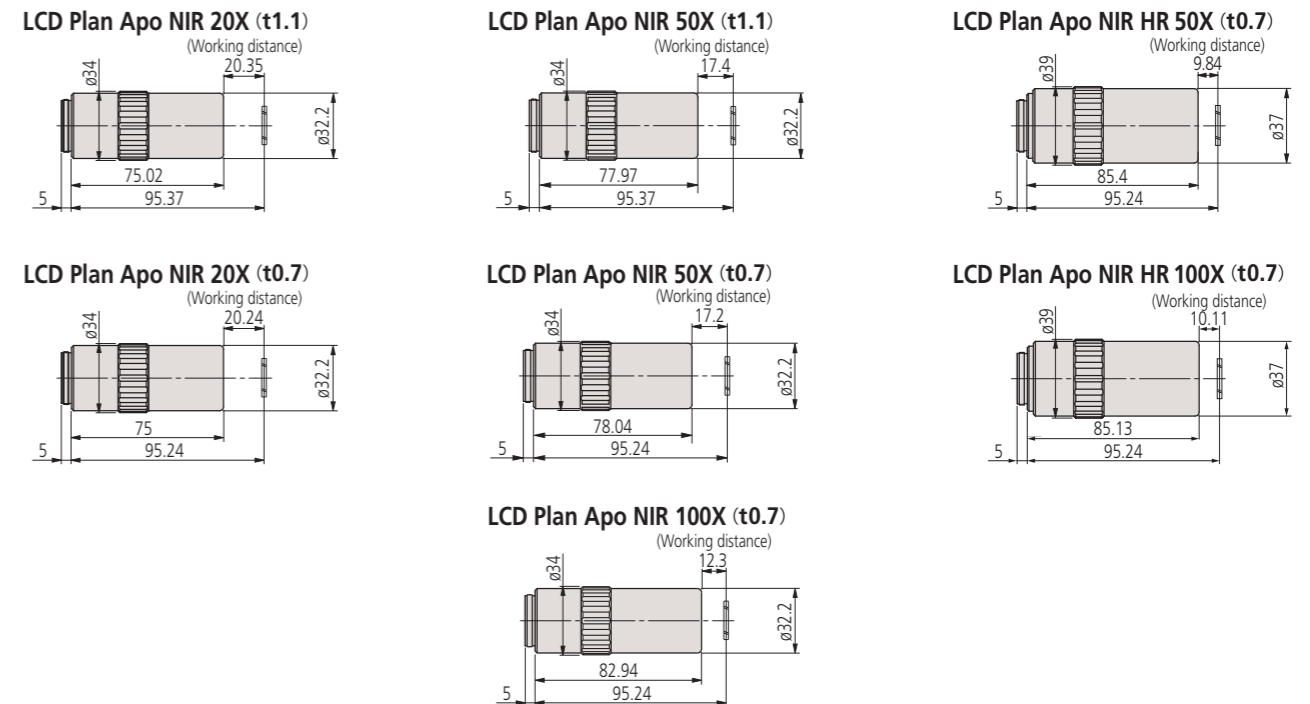

Specifications

Model	Order No.	N.A.	W.D. (mm)	f (mm) (λ=550 nm)	R (μm) (λ=550 nm)	±DOF (μm)	Real FOV (mm)		Mass (g)
							ø24 eyepiece	1/2 inch camera	
<b>LCD Plan Apo NIR</b>									
LCD Plan Apo NIR 20X (t1.1)	378-827-16	0.40	19.98*	10	0.7	1.7	1.2	0.24x0.32	305
LCD Plan Apo NIR 20X (t0.7)	378-821-16	0.40	20.00*	10	0.7	1.7	1.2	0.24x0.32	305
LCD Plan Apo NIR 50X (t1.1)	378-828-17	0.42	17.03*	4	0.7	1.6	0.48	0.10x0.13	350
LCD Plan Apo NIR 50X (t0.7)	378-829-17	0.42	16.96*	4	0.7	1.6	0.48	0.10x0.13	350
LCD Plan Apo NIR 100X (t0.7)	378-754-15	0.50	12.06*	2	0.6	1.1	0.24	0.05x0.06	335
<b>LCD Plan Apo NIR HR</b>									
LCD Plan Apo NIR HR 50X (t0.7)	378-869-5	0.65	9.6*	4	0.4	0.7	0.48	0.10x0.13	450
LCD Plan Apo NIR HR 100X (t0.7)	378-870-15	0.70	9.87	2	0.4	0.7	0.24	0.05x0.06	490

\* Every resolution and single objective's depth of focus in the above table is a value determined on the basis of a reference wavelength (λ=0.55 μm).  
\* In air

# Near-ultraviolet radiation range objectives for Bright-field observation

## M Plan Apo NUV / M Plan Apo NUV HR



VMU FS70

- Features**
- > Bright-field observation/Near-ultraviolet observation/Laser machining
  - > Wavelength compensation range 355 nm to 620 nm
  - > Infinity corrected
  - > Long working distance
  - > Plan-Apochromat
  - > High-resolving power typ (M Plan Apo NUV HR)

### Dimensions

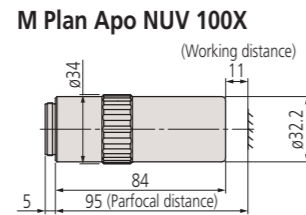
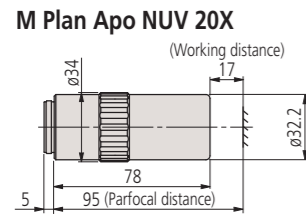
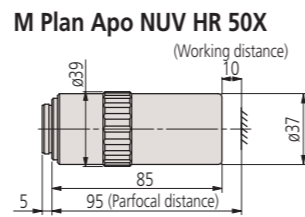
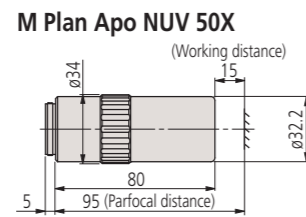
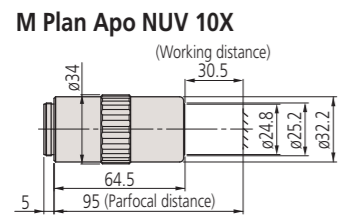

### Specifications

Model	Order No.	N.A.	W.D. (mm)	f (mm) (λ=550 nm)	R (μm) (λ=550 nm)	±DOF (μm)	Real FOV (mm)		Mass (g)
							ø24 eyepiece	1/2 inch camera	
<b>M Plan Apo NUV</b>									
M Plan Apo NUV 10X	378-809-5	0.28	30.5	20	1	3.5	2.4	0.48x0.64	255
M Plan Apo NUV 20X	378-817-8	0.42	17.0	10	0.7	1.6	1.2	0.24x0.32	340
M Plan Apo NUV 50X	378-818-8	0.44	15.0	4	0.6	1.4	0.48	0.10x0.13	350
M Plan Apo NUV 100X	378-819-15	0.50	11.0	2	0.6	1.1	0.24	0.05x0.06	380
<b>M Plan Apo NUV HR</b>									
M Plan Apo NUV HR 50X	378-888-6	0.65	10.0	4	0.42	0.65	0.48	0.10x0.13	500

• Every resolution and single objective's depth of focus in the above table is a value determined on the basis of a reference wavelength (λ=0.55 μm).

# Near-ultraviolet radiation range objectives for Bright-field observation (with cover-glass thickness compensation)

## LCD Plan Apo NUV / LCD Plan Apo NUV HR



VMU FS70

- Features**
- > Bright-field observation/Near-ultraviolet observation/Laser machining
  - > Wavelength compensation range 355 nm to 620 nm
  - > Infinity corrected
  - > Long working distance
  - > Plan-Apochromat
  - > Design enables observation through a 3.5 mm cover glass (material: BK7).
  - Note: Mitutoyo is ready to design and manufacture a specific sheet of glass according to a specified glass thickness, material or refractive index, please contact your local Mitutoyo sales office.
  - > High-resolving power typ (LCD Plan Apo NUV HR)

### Dimensions

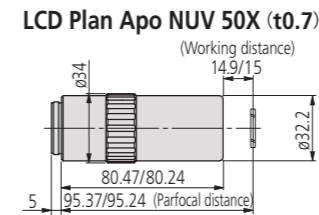
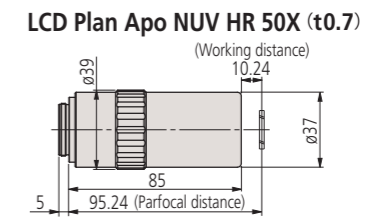
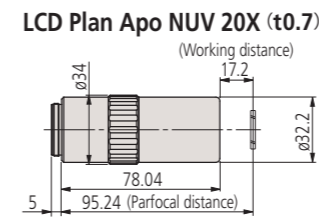

### Specifications

Model	Order No.	N.A.	W.D. (mm)	f (mm) (λ=550 nm)	R (μm) (λ=550 nm)	±DOF (μm)	Real FOV (mm)		Mass (g)
							ø24 eyepiece	1/2 inch camera	
<b>LCD Plan Apo NUV</b>									
LCD Plan Apo NUV 20X (t0.7)	378-890-8	0.42	16.96 *	10	0.7	1.6	1.2	0.24x0.32	340
LCD Plan Apo NUV 50X (t0.7)	378-820-8	0.44	14.76 *	4	0.6	1.4	0.48	0.10x0.13	350
<b>LCD Plan Apo NUV HR</b>									
LCD Plan Apo NUV HR 50X (t0.7)	378-891-6	0.65	9.76 *	4	0.4	0.7	0.48	0.10x0.13	500

• Every resolution and single objective's depth of focus in the above table is a value determined on the basis of a reference wavelength (λ=0.55 μm).

\* In air

## Ultraviolet radiation range objectives for Bright-field observation

# M Plan UV

VMU FS70



- Features**
- > Bright-field observation/Ultraviolet observation/Laser machining
  - > Wavelength compensation 266 nm and 550 nm
  - > Infinity corrected
  - > Long working distance
  - > Plan

### Dimensions

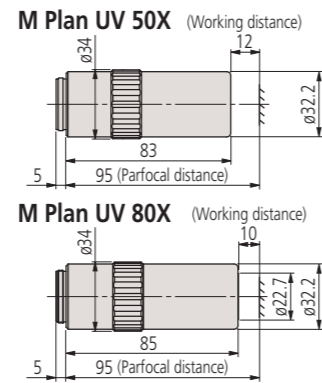
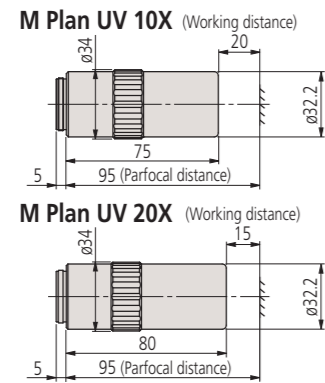

### Specifications

Model	Order No.	N.A.	W.D. (mm)	f (mm)		R (μm) (λ=550 nm)	±DOF (μm)	Real FOV (mm)		Mass (g)
				f <sub>266</sub>	f <sub>550</sub>			ø24 eyepiece	1/2 inch camera	
<b>M Plan UV</b>										
<b>M Plan UV 10X</b>	<b>378-844-15</b>	0.25	20.0	20	20.3	1.1	4.4	2.4	0.48×0.64	310
<b>M Plan UV 20X</b>	<b>378-837-8</b>	0.37	15.0	10	10.4	0.7	2.0	1.2	0.24×0.32	370
<b>M Plan UV 50X</b>	<b>378-838-8</b>	0.41	12.0	4	4.2	0.7	1.6	0.48	0.10×0.13	400
<b>M Plan UV 80X</b>	<b>378-839-5</b>	0.55	10.0	2.5	2.9	0.5	0.9	0.3	0.06×0.08	380

• When projecting a mask image on a specimen by using a YAG laser system mounted on a Mitutoyo microscope unit, the mask image will be scaled by the factor f/200 times (f=200 mm, Mitutoyo tube lens). Since the focal length (f) in ultraviolet radiation (λ=266 nm) is slightly smaller than that in visible radiation (λ=550 nm) as above, the working area in ultraviolet radiation also becomes slightly smaller than the mask image in visible radiation.  
 • Every resolution and single objective's depth of focus in the above table is a value determined on the basis of a reference wavelength (λ=0.55 μm).  
 \* In air

## Ultraviolet radiation range objectives for Bright-field observation (with cover-glass thickness compensation)

# LCD Plan UV

VMU FS70

- Features**
- > Bright-field observation/Ultraviolet observation/Laser machining
  - > Wavelength compensation 266 nm and 550 nm
  - > Infinity corrected
  - > Long working distance
  - > Plan
  - > Design enables observation through a 3.5 mm cover glass (material: sio2).  
 Note: Mitutoyo is ready to design and manufacture a specific sheet of glass according to a specified glass thickness, material or refractive index, please contact your local Mitutoyo sales office.

### Dimensions

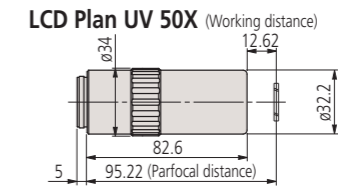
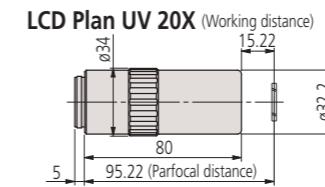

### Specifications

Model	Order No.	N.A.	W.D. (mm)	f (mm)		R (μm) (λ=550 nm)	±DOF (μm)	Real FOV (mm)		Mass (g)
				f <sub>266</sub>	f <sub>550</sub>			ø24 eyepiece	1/2 inch camera	
<b>LCD Plan UV</b>										
<b>LCD Plan UV 20X (t0.7)</b>	<b>378-892-8</b>	0.37	14.98 *	10	10.4	0.7	2.0	1.2	0.24×0.32	370
<b>LCD Plan UV 50X (t0.7)</b>	<b>378-893-8</b>	0.41	12.38 *	4	4.2	0.7	1.6	0.48	0.10×0.13	400

• When projecting a mask image on a specimen by using a YAG laser system mounted on a Mitutoyo microscope unit, the mask image will be scaled by the factor f/200 times (f=200 mm, Mitutoyo tube lens). Since the focal length (f) in ultraviolet radiation (λ=266 nm) is slightly smaller than that in visible radiation (λ=550 nm) as above, the working area in ultraviolet radiation also becomes slightly smaller than the mask image in visible radiation.  
 • Every resolution and single objective's depth of focus in the above table is a value determined on the basis of a reference wavelength (λ=0.55 μm).  
 \* In air

# Tube Lens MT

## Aberration correction range

- MT-1, 2, 40:** Visible wavelength range (435.8 – 656.3 nm)
- MT-L:** Near-ultraviolet (355 nm) to near-infrared (1800 nm)
- MT-L4:** Ultraviolet (266 nm) to visible (620 nm).

## Dimensions

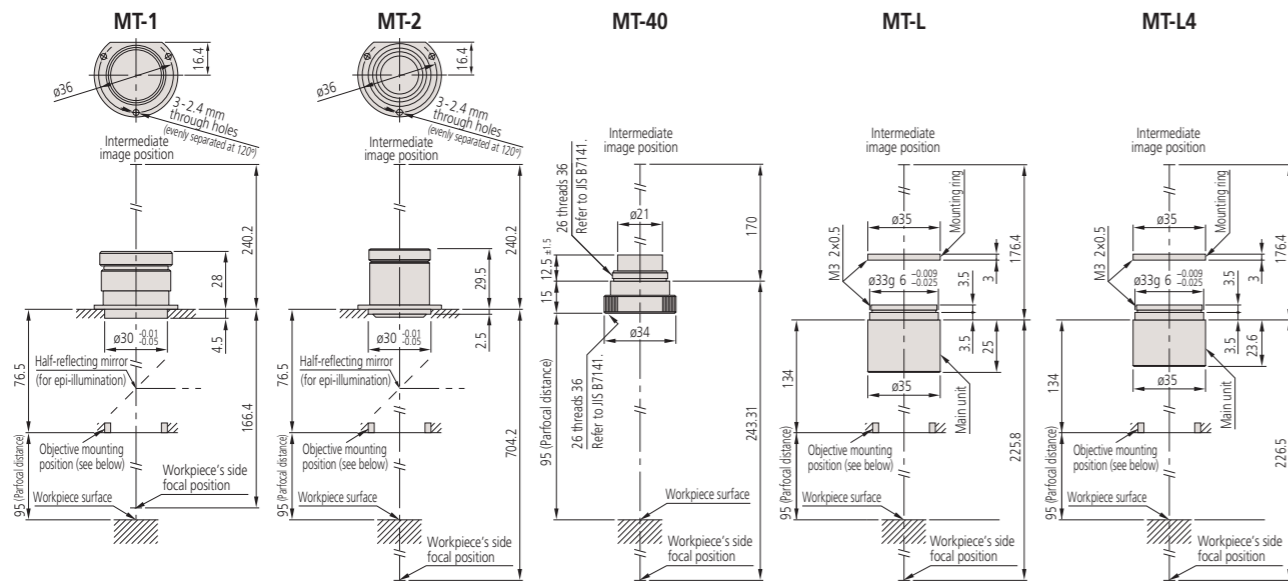

## Specifications

Order No.	Focal length (mm)	Magnification (tube lens)	Image field (mm)	Effective lens dia. (mm)	Dimensions (mm)	Mass (g)
970208	200	1X	ø30	ø24.0	ø40x32.5	43
970209	400	2X	ø30	ø18.0	ø40x32.0	42
378-010	200	1X	ø24	ø11.2	ø34x27.5	45
378-008	200	1X	ø24	ø22.0	ø35x32.0	30
378-009	200	1X	ø24	ø23.0	ø35x30.6	30

Note: A distance of 76.5mm in 970208 and 970209 drawings is for an image field of ø30 (without vignetting). For an image field of ø24 or ø11 (the latter is the image field of a 2/3-inch camera), use the formula (1) and (2) below to calculate the distance.

## Reference: Placement of Objective and Tube Lens

Mitutoyo's long working-distance objective lenses are designed to cover a field of view of up to ø30 mm (ø24 mm), when the tube lens **970208** or **970209 (378-008, 378-009 or 378-010)** is placed at the specified distance from the objective. However, use the following formula to calculate the approximate distance, when a distance other than that as specified is required in order to insert your own optical system or other optical elements:

$$\ell = (\varnothing_2 - \varnothing_1) \cdot f_2 / \varnothing \dots\dots\dots(1)$$

$$\varnothing_1 = 2 \cdot f \cdot N.A. \dots\dots\dots(2)$$

- $\varnothing_1$  : Objective exit pupil diameter (mm)
- $\varnothing_2$  : Effective diameter of tube lens (mm)
- $f_2$  : Focal length of tube lens (mm)
- $\varnothing$  : Image field diameter (mm)

Example: What is the distance ( $\ell$ ), when using **M Plan Apo 10X\*** and tube lens\*\* (**970208**) to cover an image field of ø24?

\* $f=20$  mm, N.A.=0.28 (Refer to page 19.) \*\* $\varnothing_2=24$  mm,  $f_2=200$  mm (Refer to the above chart.)

$$\text{From formula (2): } \varnothing_1 = 2 \times 20 \times 0.28 = 11.2 \text{ (mm)}$$

$$\text{From formula (1): } \ell = (24 - 11.2) \times 200 / 24 = 106.6 \text{ (mm)}$$

Therefore a distance ( $\ell$ ) up to 106 mm can cover an image field of ø24 without shading.

In other words a distance ( $\ell$ ) smaller than the specification does not affect optical performance. Contact Mitutoyo for detailed information.

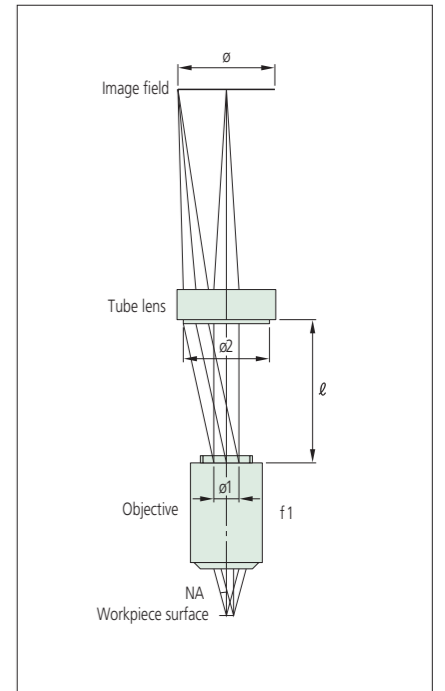

## Objectives for Measuring Microscopes ML

MF Hyper MF



- Features**
- > Finite-correction (image-object distance: 280 mm, parfocal length: 110 mm)
  - > Bright-field observation
  - > Long working distance
  - > Telecentric for lenses lower than 10X magnification

### Dimensions

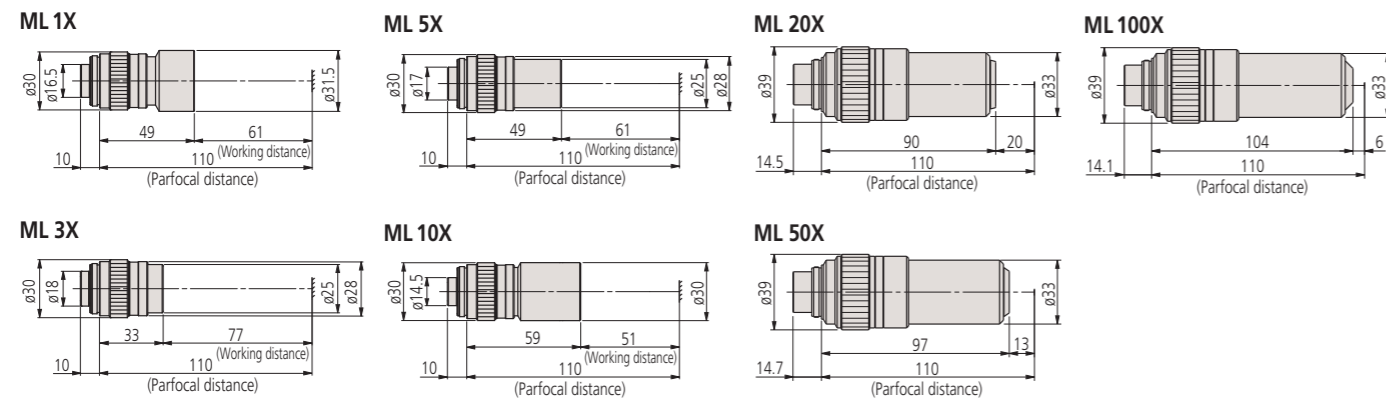

Note: The parfocal distance is a nominal value.

### Specifications

Model	Order No.	N.A.	W.D. (mm)	R ( $\mu\text{m}$ ) ( $\lambda=550\text{ nm}$ )	$\pm\text{DOF}$ ( $\mu\text{m}$ )	Real FOV (mm)		Mass (g)
						$\phi 24$ eyepiece	1/2 inch camera	
ML 1X	375-036-2	0.03	61.0	9.2	306	24	4.8x6.4	80
ML 3X	375-037-1	0.09	77.0	3.06	34	8	1.6x2.1	55
ML 5X	375-034-1	0.13	61.0	2.12	16.3	4.8	0.96x1.28	60
ML 10X	375-039	0.21	51.0	1.31	6.2	2.4	0.48x0.64	95
ML 20X	375-051	0.42	20.0	0.65	1.6	1.2	0.24x0.32	310
ML 50X	375-052	0.55	13.0	0.5	0.9	0.48	0.10x0.13	350
ML 100X	375-053	0.70	6.0	0.4	0.6	0.24	0.05x0.06	380

• Every resolution and single objective's depth of focus in the above table is a value determined on the basis of a reference wavelength ( $\lambda=0.55\ \mu\text{m}$ ).

## Objectives for Centering microscopes CF

CF

- Features**
- > Finite-correction (image-object distance: 280 mm, parfocal length: 110 mm)
  - > Bright-field observation
  - > Long working distance

### Dimensions

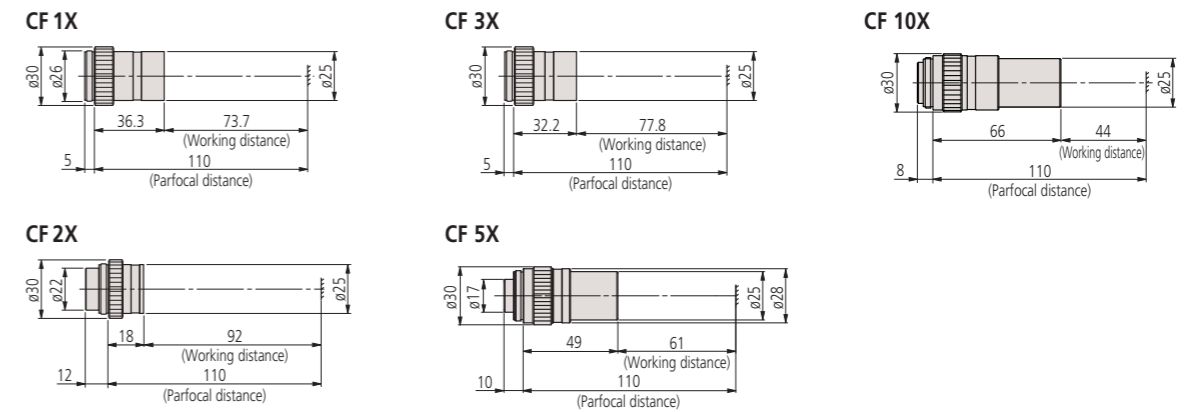

Note: The parfocal distance is a nominal value.

### Specifications

Model	Order No.	N.A.	W.D. (mm)	R ( $\mu\text{m}$ ) ( $\lambda=550\text{ nm}$ )	$\pm\text{DOF}$ ( $\mu\text{m}$ )	Real FOV (mm)		Mass (g)
						$\phi 24$ eyepiece	1/2 inch camera	
CF 1X	375-031	0.03	73.7	9.2	306	24	4.8x6.4	45
CF 2X	375-032	0.06	92.0	4.6	76	12	2.4x3.2	35
CF 3X	375-033	0.07	77.8	3.9	56	8	1.6x2.1	35
CF 5X	375-034-1	0.13	61.0	2.12	16.3	4.8	0.96x1.28	60
CF 10X	375-035	0.18	44.0	1.5	8	2.4	0.48x0.64	100

• Every resolution and single objective's depth of focus in the above table is a value determined on the basis of a reference wavelength ( $\lambda=0.55\ \mu\text{m}$ ).



## Wide Field of View Eyepieces and Reticles WF

MF MF-U Hyper MF Hyper MF-U FS70

- Features**
- > Eyepiece for wide field of view
  - > Adopt an outside focus type of optical system
  - > Various reticles can be attached according to usage purposes

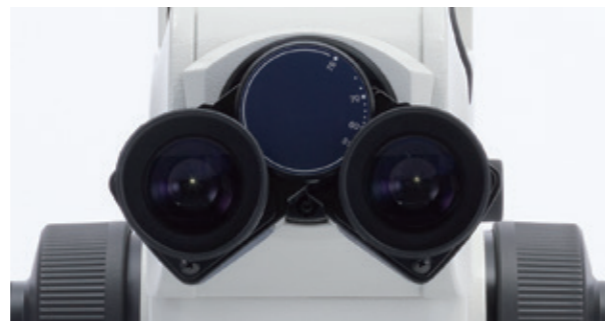

### Dimensions

WF 10X/24

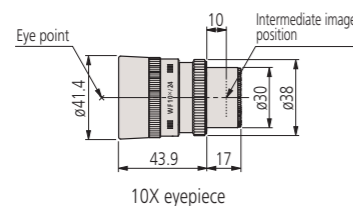

WF 20X/12

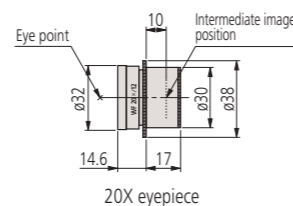

### Specifications

Order No. (2pcs.)	Model	Magnification	Field number	Visibility adjustment	Eye point	Reticle	Mass (g)
378-866	Wide field of view eyepiece WF10X/24	10x	24	-10D to +5D	High eye point	Available	150
378-858	Wide field of view eyepiece WF20X/12	20x	12	-8D to +5D	Normal	Available	55

Note: The above lenses are provided as a set of 2.

## Reticles

- Features**
- > Wide field of view, especially the UWF 10X type (30 field number)
  - > External focusing system\* allows installing an optional reticle. \*Except for UWF 10X

### Dimensions

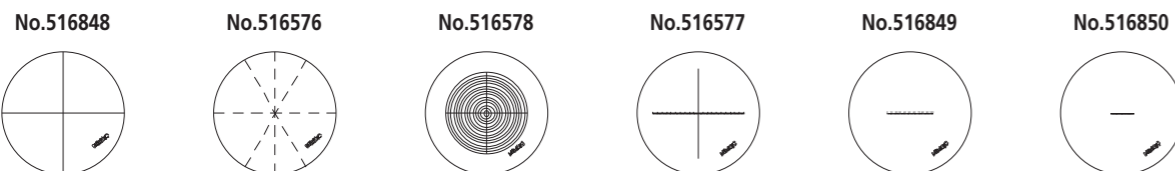

### Specifications

Order No.	516848	516576	516578	516577	516849	516850
Remarks	Solid crosshairs	90° and 60° broken crosshairs	Concentric circles (φ1.2-18 mm) with solid crosshairs	Solid crosshairs with scale graduated 0.1 mm/20 mm	10 mm scale with 0.1 mm graduations	5 mm scale with 0.05 mm graduations

## Optional Accessories for Microscopes

### Stand

For mounting the VMU, WIDE VMU, or FS70 microscope unit. Can be combined with an XY stage, stage illumination unit and fiber-optic illuminator to work as a compact microscope for surface observation.



Order No.	378-730
Mass	6.7 kg

Stand with XY stage and stage illumination unit mounted on FS70Z with optional objectives and eyepieces

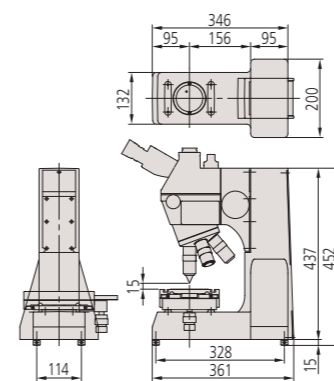

### XY stage

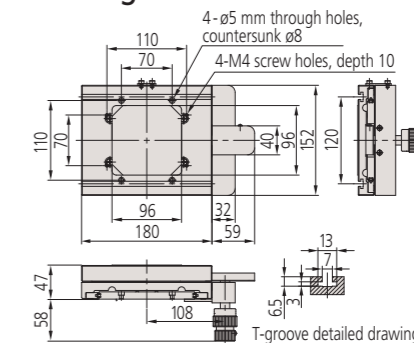

Order No.	378-020
Travel range	50x50 mm
Handle feed	34 mm/rev.
Mass	3.3 kg

Note: Each wheel functions as a single-axis drive.

### Stage illumination unit

Attaches to the stand to provide contour illumination in conjunction with a fiber-optic illuminator (100 W or 150 W).

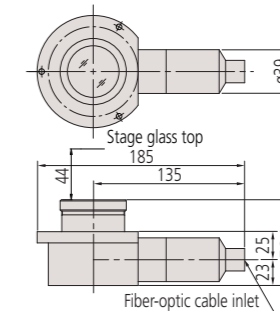

Order No.	378-736
Mass	0.8 kg

### Fiber-optic illuminator (LED)

#### • Light guide



#### • Light source

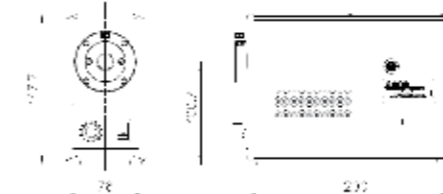

Order No.	176-386
Light source	White, 30,000 h service life*1, 6,500K (typ.)*2
Rated input	AC 100 V - AC 240 V ±10%, 50/60 Hz
Rated power consumption	20 W
Light guide	Fiber-optic cable (1.5 m length, 5 mm dia.)
Brightness	Adjustable by volumn

\*1: The LED service life may vary depending on the usage environment. This value is not a guarantee of the service life.

\*2: Color temperature (given as reference)

### Fiber-optic illuminator (150 W)

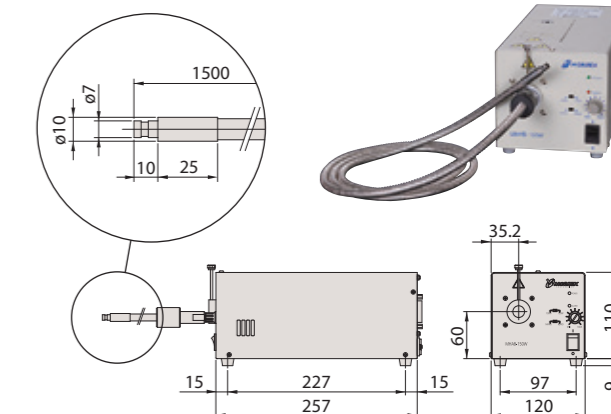

Order No.	176-316	
Light source	Long-life type	15 V/150 W parabolic-type halogen bulb (12BAJ076), 500h service life
	High-brightness type	15 V/150 W parabolic-type halogen bulb (12BAJ075), 50h service life
Light guide	Fiber-optic cable (1.5 m length, 5 mm dia.)	
Brightness	Adjustable by rotary control	

# Dimensions

## VMU

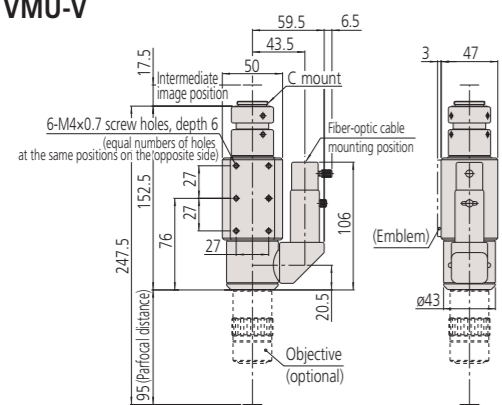

## VMU-H

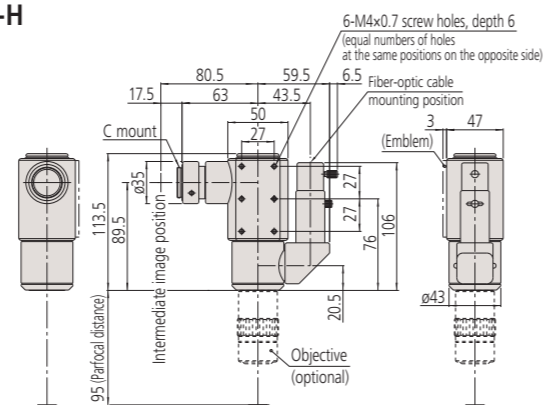

## VMU-LB

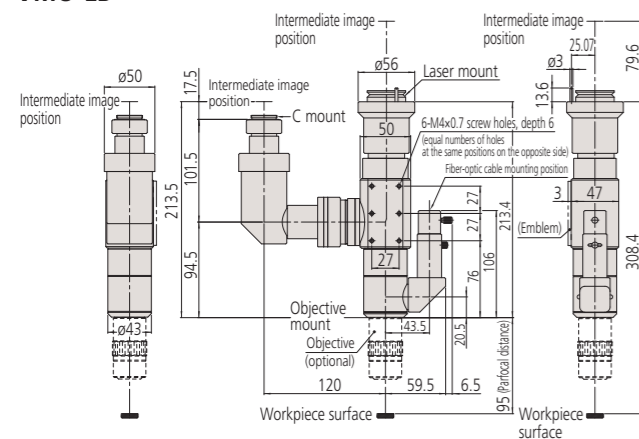

## VMU-L4B

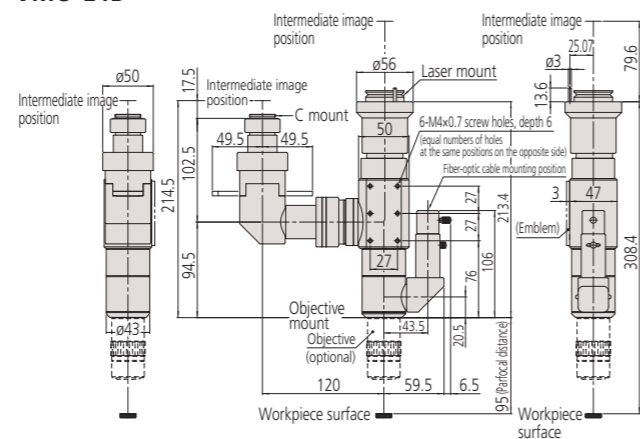

## WIDE VMU

### WIDE VMU-HR

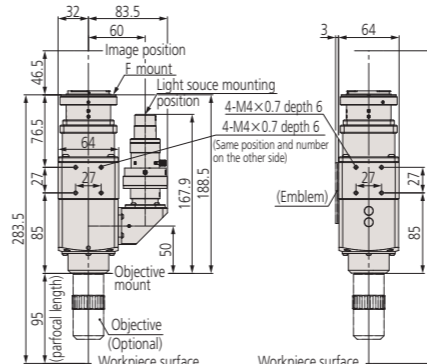

## WIDE VMU-BDV

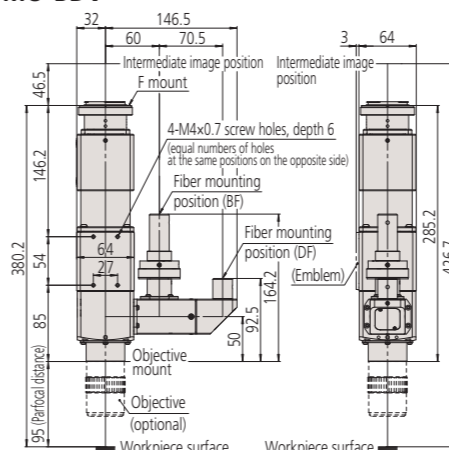

## WIDE VMU-BDH

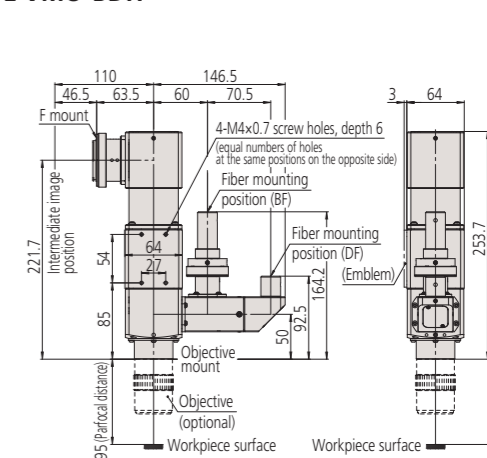

## FS70

### FS70Z (FS70ZD)

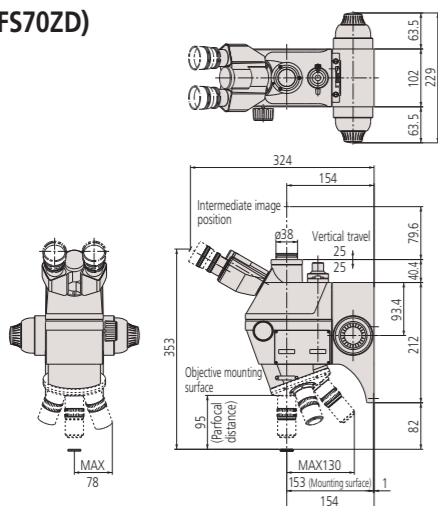

### FS70L

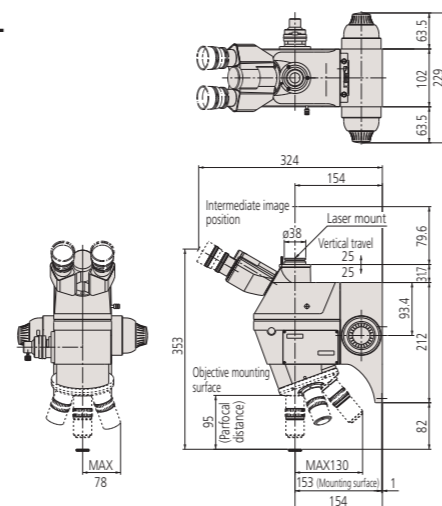

### FS70L4

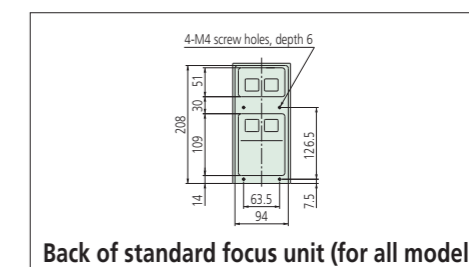
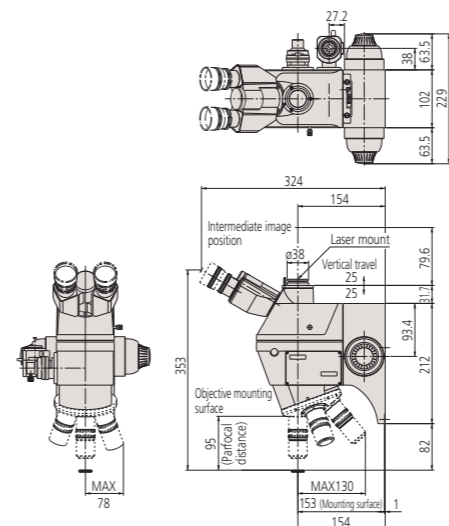

Back of standard focus unit (for all models)

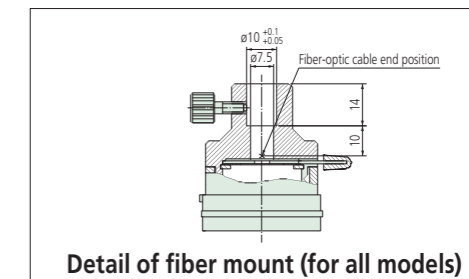

Detail of fiber mount (for all models)

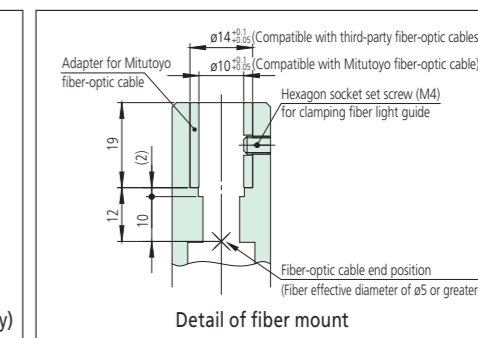
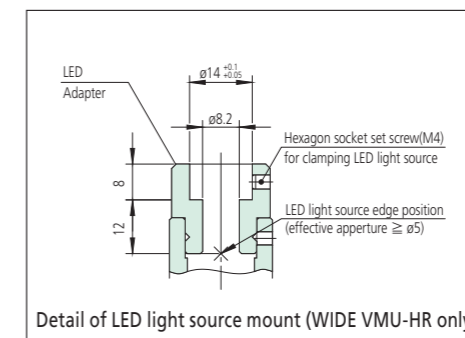
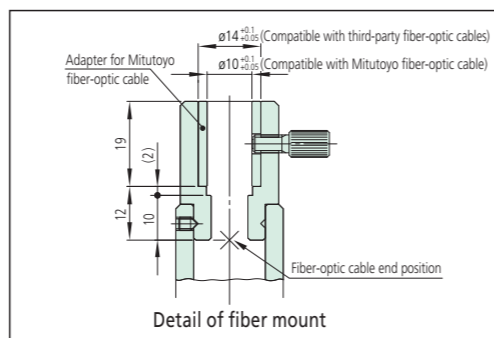

# Reference: Specifications of Objective Threads

1. Scope These specifications are applied to the threads of Mitutoyo microscope objectives.
2. The thread forms and dimensions are specified as follows conforming to JIS B-7141-1994.

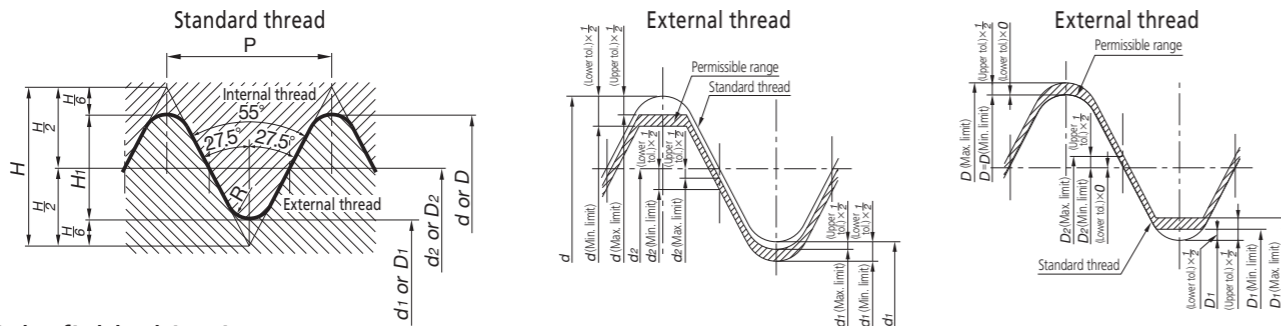

## Bright-field Objectives Measuring Microscope/Centering Microscope Objectives

Nominal Dimensions Unit: mm

Nominal thread diameter	Number of threads (per 25.4 mm) n	Pitch P	Thread peak & valley curvature radius R	External thread		
				OD (d)	Pitch diameter (d <sub>2</sub> )	Root diameter (d <sub>1</sub> )
				Root diameter (D)	Pitch diameter (D <sub>2</sub> )	ID (D <sub>1</sub> )
26	36	0.706	0.097	26.000	25.548	25.096

Permissible Limits of Size and Dimensional Tolerance Unit: mm

Applicable dimensions	External thread			Internal thread			
	OD (d)	Pitch diameter (d <sub>2</sub> )	Root diameter (d <sub>1</sub> )	Root diameter (D)	Pitch diameter (D <sub>2</sub> )	ID (D <sub>1</sub> )	
Permissible limits	Max. limit	25.896	25.502	25.050	26.076	25.624	25.230
	Min. limit	25.820	25.426	24.974	26.000	25.548	25.154
Dimensional tolerance	Upper tolerance	-0.104	-0.046	-0.046	+0.076	+0.076	+0.134
	Lower tolerance	-0.180	-0.122	-0.122	0	0	+0.058

## Bright/Dark-field Objectives

Nominal Dimensions Unit: mm

Nominal thread diameter	Number of threads (per 25.4 mm) n	Pitch P	Thread peak & valley curvature radius R	External thread		
				OD (d)	Pitch diameter (d <sub>2</sub> )	Root diameter (d <sub>1</sub> )
				Root diameter (D)	Pitch diameter (D <sub>2</sub> )	ID (D <sub>1</sub> )
40	36	0.706	0.097	40.000	39.548	39.096

Permissible Limits of Size and Dimensional Tolerance Unit: mm

Applicable dimensions	External thread			Internal thread			
	OD (d)	Pitch diameter (d <sub>2</sub> )	Root diameter (d <sub>1</sub> )	Root diameter (D)	Pitch diameter (D <sub>2</sub> )	ID (D <sub>1</sub> )	
Permissible limits	Max. limit	39.896	39.502	39.050	40.076	39.624	39.230
	Min. limit	39.820	39.426	38.974	40.000	39.548	39.154
Dimensional tolerance	Upper tolerance	-0.104	-0.046	-0.046	+0.076	+0.076	+0.134
	Lower tolerance	-0.180	-0.122	-0.122	0	0	+0.058

# Reference: Transmission of Mitutoyo Objectives

Mitutoyo's long working-distance objectives are grouped by working wavelength range: ultraviolet, near-ultraviolet, visible, and near-infrared. The M Plan UV series (for ultraviolet), M Plan Apo NUV series (for near-ultraviolet), and M Plan Apo NIR series (for near-infrared) are designed especially for YAG laser working applications in cutting thin films. Each series is designed for optimal spectral transmission factor within its respective wavelength range.

**M (BD) Plan Apo** series: Wavelength range 436 nm to 656 nm

**M Plan Apo NIR** series: Wavelength range 480 nm to 1800 nm

**M Plan Apo NUV** series: Wavelength range 355 nm to 620 nm

**M Plan UV** series: Optimized for wavelengths of 266 nm and 550 nm

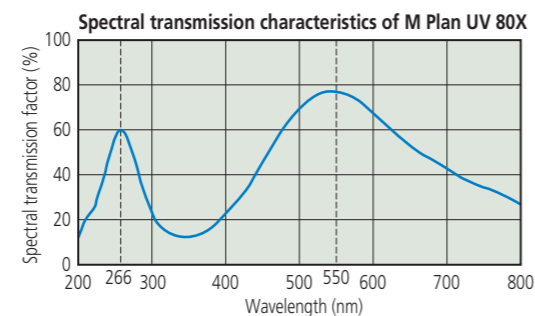
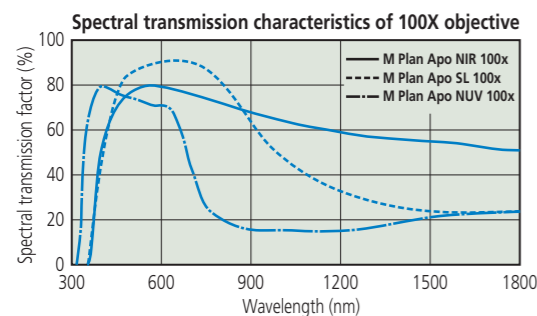

N.A.: Numerical aperture W.D.: Working distance f: Focal length R: Resolving power DOF: Depth of field FOV: Real field of view

# Commentary: Laser Operating Method and Precautions

Each VMU and FS70 series of Mitutoyo microscope units uses a built-in laser [mainly, Nd-YAG laser fundamental wave (1064 nm), second harmonic (532 nm), third harmonic (355 nm) and fourth harmonic (266 nm)] to allow laser machining. In laser machining with a laser-equipped microscope unit and a microscope objective, high-power laser irradiation is not allowed for the purpose of microfabrication.

IMPORTANT: Review laser safety precautions prior to use.

## Laser Input Conditions of Laser-equipped Microscope Unit

Determine the upper limit value of laser input under the following conditions. Laser radiation incident on the optical system shall be axial and non-polarized.

### VMU Series

Applicable model	VMU-LB			VMU-L4B			
	1064	532	355	1064	532	355	266
Wavelength used (nm)	1064	532	355	1064	532	355	266
Pulse laser							
Upper input limit (J/cm <sup>2</sup> )	0.099	0.075	0.025	0.11	0.080	0.035	0.015
Pulse width (10 ns)							
Upper limit to CW laser input (kW/cm <sup>2</sup> )	0.22	0.18	0.07	0.2	0.19	0.05	0.05

### FS70 Series

Applicable model	FS70L			FS70L4	
	1064	532	355	532	266
Wavelength used (nm)	1064	532	355	532	266
Pulse laser					
Upper input limit (J/cm <sup>2</sup> )	0.090	0.075	0.018	0.075	0.015
Pulse width (10 ns)					
Upper limit to CW laser input (kW/cm <sup>2</sup> )	0.23	0.18	0.06	0.2	0.05

## Upper Limit to Objective Laser Input

Determine the upper limit value of laser input under the following conditions if the laser radiation directly enters the objective.

Laser radiation incident on the optical system shall be axial.

### VMU Series

Applicable objective	NIR series	NIR series NUV series UV series	NUV series	UV series
	Wavelength used (nm)	1064	532	355
Pulse laser				
Upper input limit (J/cm <sup>2</sup> )	0.2	0.1	0.05	0.04
Pulse width (10 ns)				
Upper limit to CW laser input (kW/cm <sup>2</sup> )	0.5	0.25	0.16	0.12

Note: If the pulse width of the laser is shortened, reduce the irradiation energy density by the square root of the ratio of the new pulse width to the initial pulse width.

Example: If the pulse width decreases to 1/4 of the initial width, reduce the energy density to approximately 1/2.

Therefore when using a laser with a wavelength of 1064 nm and a pulse width of 2.5 ns, the upper limiting value of input will be 0.1 J/cm<sup>2</sup>.

# Glossary

## 1. N.A. (Numerical Aperture)

N.A. determines resolving power, depth of field, and luminosity of the image. The larger the N.A. the higher is the resolving power and smaller is the depth of field.

$$N.A. = n \cdot \sin\theta$$

n is the index of refraction of the medium in which the lens is working. n=1.0 for air.

θ is the half-angle of the maximum cone of light that can enter or exit the lens.

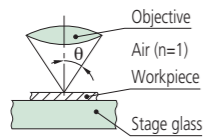

## 2. R (Resolving Power)

Minimum distance between points or lines that are just distinguishable as separate entities.

Resolving power is determined by N.A. and wavelength λ.

$$R (\mu m) = \frac{\lambda}{2 \cdot N.A.}$$

## 3. W.D. (Working distance)

Distance between the surface of the specimen and the front face of the objective when in focus.

## 4. Parfocal Length

Distance between the surface of the specimen and the objective's seating surface when in focus.

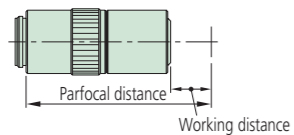

## 5. Infinity-corrected optical system

An optical system in which the image is formed by an objective and a tube lens with an 'Infinity Space' between them, into which optical accessories can be inserted.

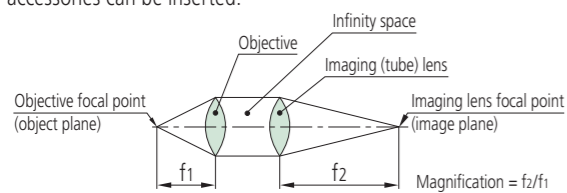

## 6. Finite-corrected optical system

An optical system in which the image is formed only by an objective lens.

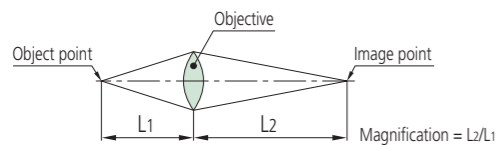

## 7. F (Focal Length)

Distance between a principal point and a focal point. f<sup>1</sup> is the focal length of an objective, f<sup>2</sup> is the focal length of a tube lens. Magnification is determined by the ratio of the focal length of the tube lens to that of the objective. (For an infinity-corrected optical system.)

$$\text{Magnification of objective} = \frac{\text{Focal length of tube lens}}{\text{Focal length of objective}}$$

(E.g.) 1X =  $\frac{200 \text{ (mm)}}{200 \text{ (mm)}}$  (E.g.) 10X =  $\frac{200 \text{ (mm)}}{20 \text{ (mm)}}$

## 8. Field number and FOV (Real Field of View)

The field number of an eyepiece is determined by the field stop diameter of the eyepiece and it is expressed in mm.

FOV is the area of specimen observable and is determined by the field number of the eyepiece and magnification of the objective.

$$FOV \text{ (mm)} = \frac{\text{Field number of eyepiece}}{\text{Magnification of objective}}$$

(E.g. Using an eyepiece of field number 24)

$$FOV \text{ for 1X objective} = \frac{24}{1} = \phi 24 \text{ (mm)}$$

$$FOV \text{ for 10X objective} = \frac{24}{10} = \phi 2.4 \text{ (mm)}$$

## Area of specimen observable on TV monitor

$$\text{Area of specimen observable on TV monitor} = \frac{\text{Area of camera image element (VxH)}}{\text{Magnification of objective}}$$

## Indication magnification on TV monitor

$$\text{Indication magnification on TV monitor} = \text{Magnification of objective} \times \frac{\text{Diagonal line length of monitor indication}}{\text{Diagonal line length of camera image element}}$$

Note: Size of camera image element (V x H x Diagonal)  
 1/3 inch image element: 3.6x4.8x6.0 mm    1/2 inch image element: 4.8x6.4x8.0 mm  
 2/3 inch image element: 6.6x8.8x11.0 mm

## 9. DOF (Depth of Field)

Vertical distance in the specimen, measured from above and below the exact plane of focus, which still yields an acceptable image. The larger the N.A., the smaller the depth of field.

## Eyepiece observation (Formula due to Berek)

$$\pm DOF (\mu m) = \frac{\omega \times 250.000}{N.A. \times M} + \frac{\lambda}{2 \times (N.A.)^2} \quad \lambda = \text{Standard wavelength (550 nm)}$$

ω: Resolution of human eye (Visual angle: 5 minute)  
 M: Total magnification (Objective mag. x Eyepiece mag.)

## TV monitor observation

$$\pm DOF (\mu m) = \frac{\lambda}{2 \times (N.A.)^2} \quad \lambda = \text{Standard wavelength (550 nm)}$$

## 10. Bright-field illumination and dark-field illumination

Bright-field illumination directly lights the specimen with a solid cone of rays and is the simplest method available. Dark-field illumination uses a hollow cone of rays formed by an opaque stop at the center of the condenser large enough to prevent direct light from entering the objective. The specimen is placed at the concentration of the light cone, and is seen with light scattered or diffracted by it, therefore scratches and dents on the specimen surface are illuminated while the rest remains dark.

## 11. Apochromatic objective and achromatic objective

An apochromatic objective is corrected for chromatic aberration at the red, green and blue wavelengths. An achromatic objective is corrected for chromatic aberration at the red and blue wavelengths only.

## 12. Koehler illumination

Köhler illumination overcomes the disadvantages of other schemes by causing parallel rays to light the specimen so that, because they will not be in focus, the image of the specimen will not include an image of the light source.

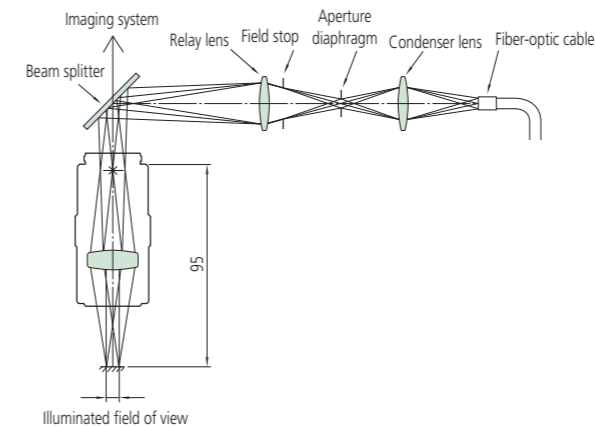

## 13. Telecentric illumination

This illuminating optical system is designed so that principal light passes through the focal point. This system has the advantage of retaining the size of the image center even if it is out of focus (although the circumference of the image is defocused). This illumination system provides an even illumination intensity over the entire field of view.

## 14. Aperture diaphragm

This diaphragm adjusts the amount of light passing through and is related to the brightness and resolving power of an optical system. This diaphragm is especially useful in width dimension measurement of cylindrical objects with contour illumination, and provides the highest degree of correct measurement/observation by suppressing diffraction in an optimal aperture.

## 15. Field stop

This diaphragm is used for blocking out unwanted light and thereby preventing it from degrading the image.

## 16. Plan

Denotes an objective lens that produces a flat (planar) image by correcting the spherical aberration/curvature of the field of an achromatic lens or an apochromatic lens. All Mitutoyo FS series objectives are plan apochromat.

## 17. Vignetting

This unwanted effect is the reduction of an image's brightness or saturation at the periphery compared to the image center. May be caused by external (lens hood) or internal features (dimensions of a multi-element lens).

## 18. Flare

Lens flare is typically seen as several starbursts, rings, or circles in a row across the image or view, caused by unwanted image formation mechanisms, such as internal reflection and scattering of light.

## 19. Double image

An image degrading a phenomenon in which an image appears as if it is a double image due to redundant light projection and optical interference within the optical system.

## 20. Pupil Diameter and Spot Diameter of an Objective

• Pupil diameter  
 Denotes the maximum diameter of a parallel light flux along the optical axis that can enter an objective from the rear. The pupil diameter is calculated according to the following expression.

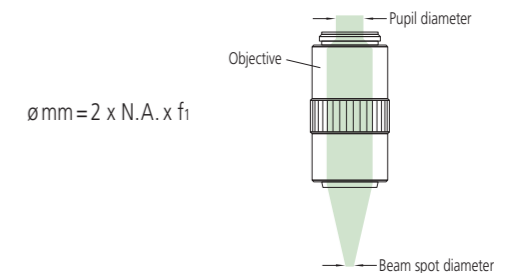

$$\phi \text{ mm} = 2 \times N.A. \times f_1$$

• Spot diameter  
 If a beam of light with a uniformly distributed intensity enters an objective from the rear, the beam is focused to a spot of finite size. This size is known as the spot diameter. The approximate value of a spot diameter is calculated from the following expression.

$$\phi \mu m = 1.22 \times \frac{\lambda}{N.A.}$$

However, the above expression cannot be applied if the light source is a laser beam of which the intensity forms a Gaussian distribution on the cross section. The diameter of a laser beam is generally indicated by 1/e<sup>2</sup> of the peak value, i.e. 13.5% of the peak value. The spot diameter of a laser beam is calculated from the following expression.

$$\phi \mu m = \frac{4 \times \lambda \times f}{\pi \times D}$$

(where λ is in μm; f and D are in mm)



### Whatever your challenges are, Mitutoyo supports you from start to finish.

Mitutoyo is not only a manufacturer of top quality measuring products but one that also offers qualified support for the lifetime of the equipment, backed up by comprehensive services that ensure your staff can make the very best use of the investment.

Apart from the basics of calibration and repair, Mitutoyo offers product and metrology training, as well as IT support for the sophisticated software used in modern measuring technology. We can also design, build, test and deliver measuring solutions and even, if deemed cost-effective, take your critical measurement challenges in-house on a sub-contract basis.



Find additional product literature and our product catalogue

<https://www.mitutoyo.co.jp/global.html>

Our products are classified as regulated items under Japanese Foreign Exchange and Foreign Trade Law. Please consult us in advance if you wish to export our products to any other country. If the purchased product is exported, even though it is not a regulated item (Catch-All controls item), the customer service available for that product may be affected. If you have any questions, please consult your local Mitutoyo sales office.

Note: Product illustrations are without obligation. Product descriptions, in particular any and all technical specifications, are only binding when explicitly agreed upon. MITUTOYO and MICAT are either registered trademarks or trademarks of Mitutoyo Corp. in Japan and/or other countries/regions. Other product, company and brand names mentioned herein are for identification purposes only and may be the trademarks of their respective holders.

# Mitutoyo

#### Mitutoyo Corporation

20-1, Sakado 1-Chome,  
Takatsu-ku, Kawasaki-shi,  
Kanagawa 213-8533, Japan  
T +81 (0) 44 813-8230  
F +81 (0) 44 813-8231  
<https://www.mitutoyo.co.jp>