

Measuring Microscope MF series

Measuring Microscope MF series

User's Manual (Hardware Guide)

Read this User's Manual thoroughly
before operating the instrument. After reading,
retain it close at hand for future reference.

Mitutoyo

CONVENTIONS USED IN THIS MANUAL

Safety Precautions

To ensure that instruments are operated correctly and safely, Mitutoyo manuals use various safety symbols (Signal Words and Safety Alert Symbols) to identify and warn against hazards and potential accidents.

The following signs indicate **general** warnings:



Indicates an imminently hazardous situation which, if not avoided, will result in serious injury or death.



Indicates a potentially hazardous situation which, if not avoided, could result in serious injury or death.



Indicates a potentially hazardous situation which, if not avoided, may result in minor or moderate injury or property damage.

The following signs indicate **specific** warnings or prohibited actions, or indicate a mandatory action:



Alerts the user to a specific hazardous situation. The given example means "Caution, risk of electric shock".



Prohibits a specific action. The given example means "Do not disassemble".



Specifies a required action. The given example means "Ground".

CONVENTIONS USED IN USER'S MANUAL

Various Types of Notes

The following types of **notes** are provided to help the operator obtain reliable measurement data through correct system operation.

-
- IMPORTANT**
- An *important* note is a type of note that provides information essential to the completion of a task. You cannot disregard this note to complete the task.
 - An *important* note is a type of precaution, which if neglected, could result in a loss of data, decreased accuracy or instrument malfunction/failure.
-

NOTE A *note* emphasizes or supplements important points of the main text. A *note* supplies information that may only apply in special cases (e.g., Memory limitations, equipment configurations, or details that apply to specific versions of a program).

TIP A *tip* is a type of note that helps the user apply the techniques and procedures described in the text to their specific needs.

It also provides reference information associated with the topic being discussed.

Mitutoyo assumes no liability to any party for any loss or damage, direct or indirect, caused by use of this instrument not conforming to this manual.

Information in this document is subject to change without notice.

© 2009 Mitutoyo Corporation. All rights reserved.

Notes on LED Safety

An LED is integrated into the illuminator in this measuring microscope, MF/MF-U series. Please observe the following to use the product in a safe manner. Operations other than described in the manual may result in dangerous radiant exposure.



CAUTION

- 1) The JIS (JIS C 6802, established in 2005) and the International Standard (IEC60825-1, established in 2001) are the safety standards for LED devices.
 - 2) The LED device is classified as “Class 1 LED product” in the JIS and IEC standards.
 - 3) Do not look into LED light.
(Never look into LED light even when light is not emitted.)
 - 4) Do not look at laser light directly with an optical instrument (light condensing device such as a magnifying glass).
 - 5) Skin exposure to LED light causes no problem.
-

Precautions for Use

- **This instrument is a measuring machine.**

Do not use this instrument for any purpose other than such measurement.
- **This instrument is a precision machine.**

Exercise great care when handling this machine. Never bump or apply excessive force to any of the parts during operation.
- **Rectify the installation environments.**

(For detailed information, refer to "Installation Environments".)

 - Close to 20°C in ambient temperature.
 - Free of extreme humidity.
 - Free of dust and dirt.
 - Free of vibration.
- **Gently fix a workpiece on the stage.**

If the stage glass or top face is subject to large impact, it could be damaged. Exercise sufficient care in fixing a workpiece or a jig.
Particularly, pay attention so as not to apply an impact to the stage glass.
- **Turn off the power during connection and maintenance.**

To avoid accidents or electric shock due to malfunction of the machine under operation, be sure to turn off the power before performing connection or maintenance.
- **Please do not carry the measurement thing of 18kg or more alone.**

Please do not carry the measurement thing to exceed 18kg alone for safety though the maximum authorized freight mass of the stage is 20kg.
- **Power supply**

Observe the following precautions regarding the power supply.

 - As a rule, the power distribution method should be a single-phase, two wire system with one wire grounded. (Pay due attention to the polarity.)
 - Be sure to ground the system. (Protective grounding) (Class D grounding) * Consult a qualified electrician or someone with equivalent knowledge for the power supply arrangement and construction.
- **Turn the power switch ON or OFF along the order**

The counter may display error messages (E51,E52,E53) by the order which turns the power supply of the microscope main unit and the peripheral equipment such as personal computer on or off in the connection with some peripheral equipment, when the peripheral equipment is being connected with the counter unit at RS232C.
Be sure to perform at the following order, when turning the power switch ON or OFF.

 - For ON ····· **Peripheral equipment** → **Microscope main unit**
 - For OFF ····· **Microscope main unit** → **Peripheral equipment**

- **Power cord**

Use only the power cord supplied with this product. Please contact us if an abnormality is observed on the power cord or power connector.

- **Removing the cover and disassembling the machine**

This machine is precisely adjusted, and is comprised of high-voltage parts. In order to prevent accident and to maintain the performance, do not absolutely remove the cover on the machine.

- **Danger prevention**

In order to prevent danger, do not use the machine in locations where volatile gases could be generated.

- **Maintenance**

Gently wipe off dirt from the machine using a lint-free and soft cloth. If the dirt is difficult to remove, wipe it clean with a cloth soaked in neutral detergent, then wipe lightly with a dry cloth or a cloth well-wrung after soaking in water. Do not use organic solvents such as thinner or benzine.

- **Take special shielding measures when using the machine in the following locations:**

- Where noise is generated due to static electricity
- Near strong electric fields
- Where power source lines pass nearby
- Where there is a risk of radioactivity
- Where the machine could be subject to corrosive gasses

Installation Environments

Temperature

This measuring microscope has been assembled and adjusted in the temperature-controlled room at 20°C. To use the microscope at the rated measuring accuracy in the specification, the temperature at the installation site should be close to 20°C with minimum temperature fluctuation. (The ideal temperature is standard temperature condition level 1, 20°C ± 1°C, that is specified as “Standard Condition of Precision Measurement Environments” in JMAS5011.) Also, the temperature gradient should be 2°C as reference for 8 hours. If this temperature environment is worse than the above condition, the microscope may not meet the specified measuring accuracy. Even if the specified accuracy is temporarily obtained by adjustment, uncertain measurements will be displayed at 20°C.

Humidity

Humidity is not directly related to the measuring microscope accuracy. If the ambient humidity is high, rust will easily form on important machined surfaces and may affect electronic parts adversely. Efforts should be made to retain humidity between 55 and 65%.

Dust and dirt

The measuring microscope consists of high-precision parts such as guide ways, linear scale units, and optical units that are apt to be easily damaged by dust and dirt. Use the microscope at a site free of dust and dirt.

Grounding

To operate the measuring microscope properly, be sure to connect the GND terminal to the earth terminal with a grounding resistance of 100Ω or less (conforming to Class 3 grounding construction). Also, if a system is to be configured along with other instruments, make sure all the instruments are properly grounded at the power supply with a complete ground terminal, and then connect the signal cables between them.

System Environments

Place	The indoor use
Use altitude	2000m or less
Use temperature	5~40°C
Use humidity	80%or less (There must not be be dewy.)

Preservation environments

Preservation temperature	-10~50°C
Preservation humidity	80%or less (There must not be be dewy.)

WARRANTY

This measuring microscope has been manufactured under Mitutoyo's rigorous quality control system. In the event that this instrument should fail within one year from the original date of purchase through normal use, we will repair or replace it at our option, free of charge, upon its prepaid return to Mitutoyo. Contact your dealer or the nearest Mitutoyo Service Center.

However, the following failure or damage may be subject to a repair charge even within the warranty period:

- 1 Unit failure or damage arising from improper handling, or unauthorized retrofit or repair by the user.
- 2 Unit failure or damage as the result of moving, dropping, or transporting after purchase.
- 3 Unit failure or damage due to fire, salt, gas, abnormal voltage, or natural catastrophe.

This Warranty is valid only in the country of original purchase.

Notes on Overseas Transfer

This product is controlled by the Export Control Regulations. Please contact Mitutoyo before transferring it abroad.

Before exporting this product confirm the final purpose of use at the export destination to prevent the product from being used for developing weapons of mass destruction or military affairs.

Disposal of Old Electrical & Electronic Equipment (Applicable in the European Union and other European countries with separate collection systems)



This symbol on the product or on its packaging indicates that this product shall not be treated as household waste. To reduce the environmental impact of WEEE (Waste Electrical and Electronic Equipment) and minimize the volume of WEEE entering landfills, please reuse and recycle.

For further information, please contact your local dealer or distributors.

CONTENTS

CONVENTIONS USED IN THIS MANUAL	i
Notes on LED Safety	iii
Precautions for Use	iv
Installation Environments	vi
System Environments	vi
Preservation environments	vi
WARRANTY	vii
Notes on Overseas Transfer	vii
Disposal of Old Electrical & Electronic Equipment (Applicable in the European Union and other European countries with separate collection systems) ..	vii
1 Overview	1-1
1.1 Outline	1-1
1.2 Name and Function of Each Part	1-2
1.2.1 Optical tube unit.....	1-4
1.2.2 Cross-travel stage unit	1-5
1.2.3 Illuminator unit	1-6
1.2.4 DRO counter unit	1-8
1.2.5 Illuminator unit	1-15
2 Installation and Setup	2-1
2.1 Installation.....	2-1
2.2 Remove the Fixing Plate	2-2
2.2.1 Removing the fixing plate for cross-travel stage	2-2
2.2.2 Removing the fixing plate for optical tube unit	2-3
2.3 Moving the Table on the Cross-Travel Stage	2-4
2.3.1 When a great and quick travel of the table is required	2-4
2.3.2 When a fine travel of the table is required.....	2-4
2.4 Moving the Optical Tube Unit	2-5
2.4.1 When a great and quick travel of the unit is required	2-5
2.4.2 When a fine travel of the unit is required	2-5
2.5 Leveling the Main Unit	2-6
2.6 Mounting (Replacing) the Eyepiece Unit.....	2-7
2.6.1 Mounting the binocular unit.....	2-7
2.6.2 Mounting the monocular unit	2-7
2.6.3 Mounting other eyepiece unit (protractor eyepiece)	2-7
2.7 Mounting the Lenses.....	2-8
2.7.1 Mounting the objective.....	2-8
2.7.2 Mounting the eyepieces	2-8
2.7.2.1 For the binocular unit.....	2-8

2.7.2.2	For the monocular unit	2-8
2.8	Installation of the Illuminators	2-9
2.8.1	For LED illuminator	2-9
2.8.2	For halogen illuminator.....	2-10
2.9	Changing the Counter Mounting Angle and Position.....	2-11
2.10	Connecting Each Part.....	2-12
3	Measurement Setup.....	3-1
3.1	Connection Check.....	3-1
3.2	Turning the Power Supply On	3-1
3.3	Confirming the Filament Position of the Halogen Illuminator	3-2
3.3.1	Confirming the filament position of the halogen vertical reflected illuminator	3-2
3.3.2	Confirming the filament position of the halogen transmitted illuminator	3-2
3.4	Adjusting the Aperture for Transmitted Illumination.....	3-3
3.5	Adjusting the Aperture for Reflected Illumination	3-5
3.6	Setting Up a Workpiece	3-6
3.7	Selecting the Illumination Method.....	3-8
3.7.1	Transmitted illumination	3-8
3.7.2	Vertical reflected illumination.....	3-8
3.7.3	Simultaneous use of transmitted and vertical reflected illumination	3-8
3.7.4	Oblique reflected illumination (Optional oblique reflected illuminator is required) ...	3-9
3.8	Selecting a Filter.....	3-10
3.9	Adjusting the Pupil Distance (The case in which the binocular unit is mounted)	3-11
3.10	Adjusting the Diopter of Eyepiece.....	3-12
3.11	Replacing the Reticle	3-12
3.12	Dimensional Measurement.....	3-13
4	Maintenance	4-1
4.1	Cleaning External Parts	4-1
4.2	Maintaining the Lens.....	4-1
4.3	Replacing Consumables.....	4-2
4.3.1	Replacing halogen bulbs	4-2
4.3.2	LED illuminator replacement.....	4-4
4.3.3	Replacing the stage glass.....	4-5
4.3.4	Replacement of conston spring.....	4-6
5	Troubleshooting.....	5-1
5.1	Main Unit	5-1
5.2	Counter Unit.....	5-2
5.3	Illuminator and Concerned Matters.....	5-3
5.4	Error Messages and Remedies	5-4
5.4.1	Counter and concerned matters	5-4
5.4.2	Illuminator and concerned matters.....	5-5
6	Specifications.....	6-1

6.1	Common Specifications.....	6-1
6.2	Standard accessories.....	6-2
6.2.1	Standard accessories for measuring microscope main unit	6-2
6.2.2	Standard accessories for illuminator.....	6-2
6.3	List of Consumable	6-3
6.4	Optional accessories	6-4
6.5	Objectives, Eyepieces Specification Table	6-5
6.6	Layout of the Optical System	6-6
6.7	Serial Data Output Specifications of the Counter	6-7
6.7.1	Connector specifications	6-7
6.7.2	Control signal	6-7
6.7.3	Data output operation.....	6-9
6.7.4	Connecting Micropak.....	6-11
6.7.5	Connecting DPU-414 (Printer)	6-12
6.7.6	Connecting QM-Data 200.....	6-14
6.8	External Dimensions	6-15
6.8.1	Main unit	6-15
6.8.2	Control unit.....	6-18
6.8.3	Cross-travel stage.....	6-19

SERVICE NETWORK

1

Overview

This chapter describes the system configuration, and the name and function of each part on the MF series Measuring Microscope.

1.1 Outline

The Mitutoyo MF series Measuring Microscope is a multi-purpose measuring microscope for factory inspection use. It can perform precision measurement of workpiece dimensions, contours and surface features. The MF series can be used in a wide range of applications in combination with a variety of accessories. It is possible to improve the system according to a specific purpose.

The MF series has the following features.

- Twisted roller is incorporated in the quick release mechanism. It allows smooth operation and eliminates the impact when switching coarse / fine feed.
- The cross-travel stage with a maximum stroke of 400 X 200mm is available as an option.
- Both right and left side of the optical tube unit is equipped with the coaxial fine / feed focusing wheels. This makes focusing operation easy.
- High-resolution measurement is supported using the counter with a resolution of 0.1 μ m (selectable from 0.1/0.5/1 μ m).
- Select either the LED type or halogen type for the illuminator.
(Either of the illuminators is a requisite selection option.)
- The LED illuminator has a long operating life (approx. 30,000 hours) and provides clear object views because lighting adjustment of the LED illuminator does not create any change in color temperature.

NOTE To use the measuring microscope safely, read "Safety Precautions" in this manual prior to use and observe the precautions.

1.2 Name and Function of Each Part

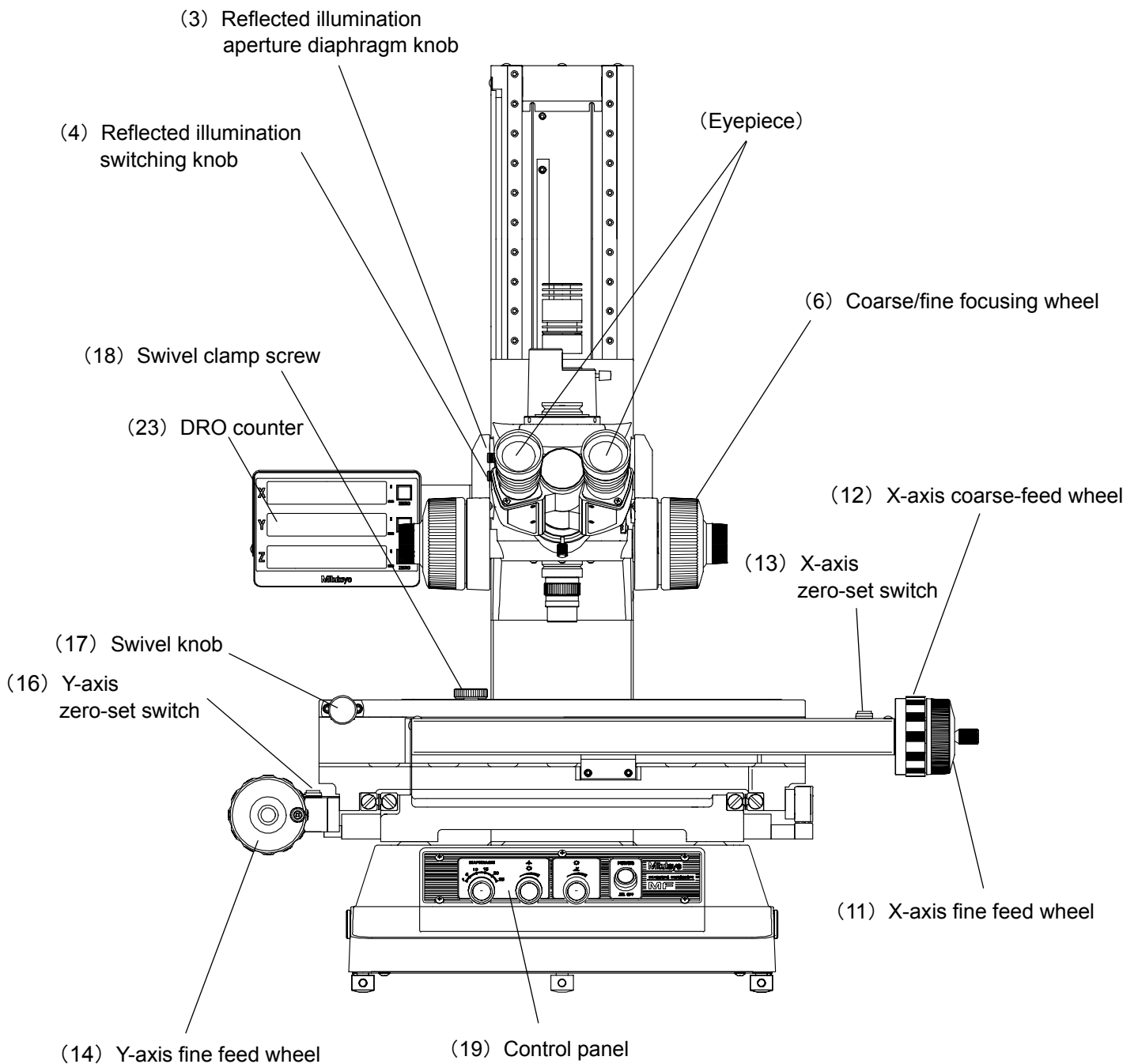

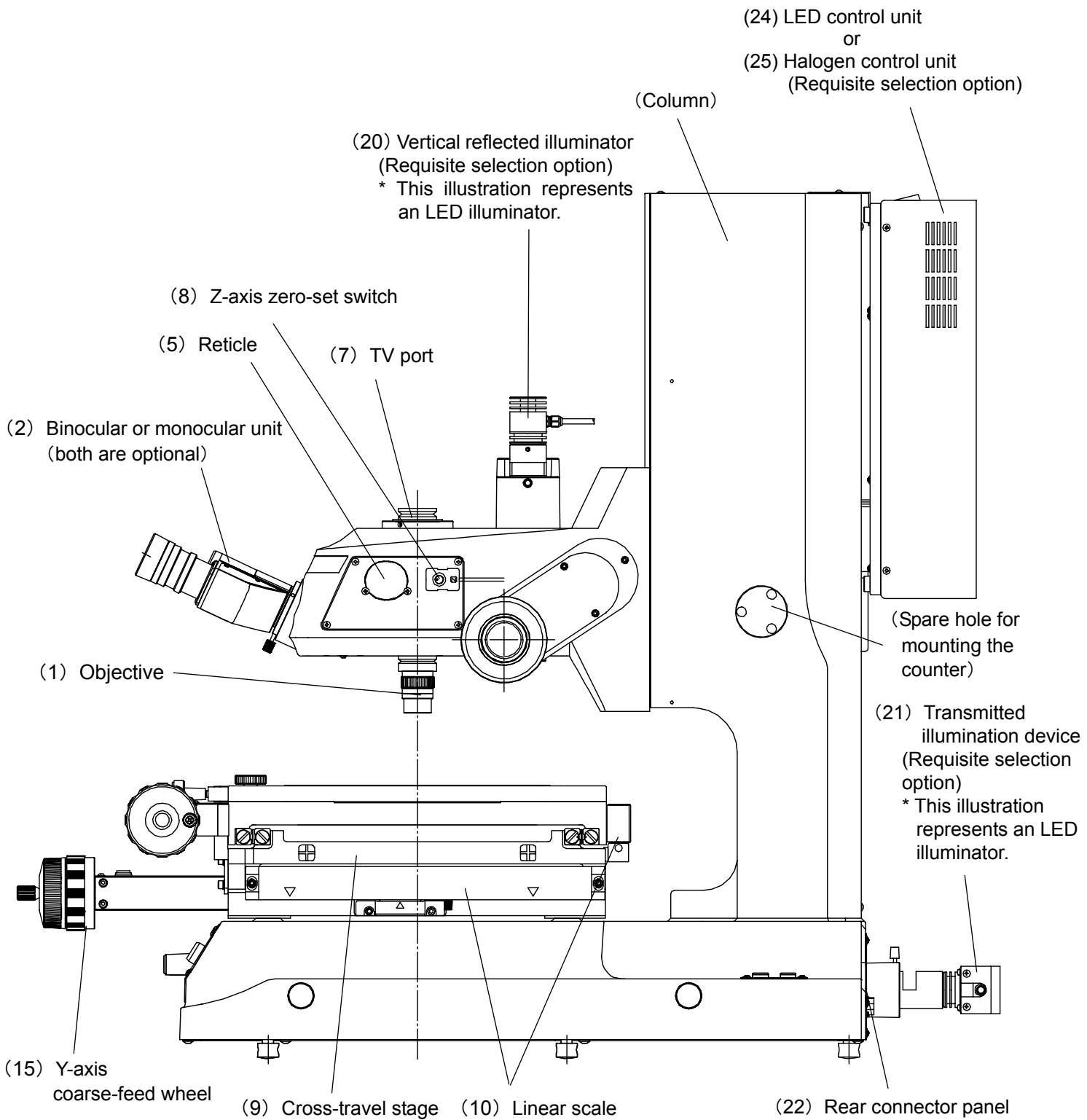

1.2.1 Optical tube unit

- 1) **Objective** : A 3X lens is mounted as standard. Various types of lenses ranging from 1X to 100X are also available as options. Selects according to the application.
- 2) **Binocular or monocular unit** (both are optional) : A 10x eyepiece is mounted on both units. A relay lens system is used in which a broken cross-hair reticle is installed in optical tube. The cross-hair in the tube is not shifted even by the pupil distance adjustment when using the binocular unit.
- 3) **Reflected illumination aperture diaphragm knob** : Adjusts the numerical aperture of the illumination system by pulling or pushing the knob.

TIP **What is Aperture diaphragm?**.....A diaphragm for controlling the light beam of an illumination system. The resolution, contrast, and depth of focus of an optical system are dependent on this aperture diaphragm. Adjust the diaphragm to the appropriate numerical aperture.

NOTE For information about adjusting the aperture diaphragm, refer to the instructions given in "3.5 Adjusting the aperture for reflected illumination".

- 4) **Reflected illumination switching knob** : Switches the optical path from one of the following sources ; the vertical reflected illuminator and the oblique illuminator (option order No.176-351-6)
- 5) **Reticle** : Loosen the cross recessed truss-head screws and remove the cover. You will see the broken cross-hair reticle with the standard line width of 5 μ m is mounted inside.
- 6) **Coarse/fine focusing wheel** : This focusing wheel allows coarse or fine vertical travels of the optical tube for focusing. The travel range and adjustments are given below.
 - Vertical travel range : 150 mm (for MF- * 505C, MF- * 1010C and MF- * 2010C)
220 mm (for MF- * 2017C, MF- * 3017C and MF- * 4020C)
 - Coarse adjustment : 30 mm per knob rotation
 - Fine adjustment : 0.2 mm per knob rotation
- 7) **TV port** : Used for mounting optional accessories (e.g. TV camera or Focus Pilot).
- 8) **Z-axis zero-set switch** (only for three axes specification) : A switch for zero-setting a Z-axis display value on the counter.

IMPORTANT

1. **When operating this switch, do not touch it with wet hand. A trouble may result. This is true for the X-axis and Y-axis zero-set switches.**
2. **A magnet is attached to the bottom surface of the Z-axis zero-set switch. It is possible to remount the switch with a single touch on a location where the switch can be operated easily.**

TIP A magnet is attached to the bottom surface of the Z-axis zero-set switch. Therefore, the switch can be moved to an operator-friendly position with a single motion.

1.2.2 Cross-travel stage unit

IMPORTANT The stage glass is made of glass to transmit the transmitted illumination light.

Do not bump the stage glass when installing a workpiece on it. If placing a heavy workpiece with protrusions on the stage glass, exercise attention so as not to scratch the glass.

- 9) **Cross-travel stage** : Mounts a workpiece on the XY stage; its stroke varies depending on the MF model.
- MF- * 505C 50mmX 50mm
 - MF- * 1010C 100mmX100mm
 - MF- * 2010C 200mmX100mm
 - MF- * 2017C 200mmX170mm (with swivel table)
 - MF- * 3017C 300mmX170mm (with swivel table)
 - MF- * 4020C 400mmX170mm (with swivel table)
-

TIP The MF- * 505C, MF- * 1010C, and MF- * 2010C models have no table rotating mechanism on the cross-travel stage. If necessary, use the fine-feed rotary table (A) (No.176-305) from the optional accessories. The fine-feed rotary table (B) (No.176-306) is also available as an option accessory for the MF- * 2017C, MF- * 3017C, and MF- * 4020C models.

- 10) **Linear scale** : Three pieces of Linear scale are mounted on each of the X- and Y-axes of the XY stage and the Z-axis column. (The Linear scale may not be mounted on the Z axis of some models.) The displacement of the stage and optical tube unit is displayed on the DRO counter.
- 11) **X-axis fine feed wheel** : Used to finely move the cross-travel stage along the X-axis direction.
- 12) **X-axis coarse-feed wheel** : Used to quickly move the cross-travel stage along the X-axis direction.
- 13) **X-axis zero-set switch** : A switch for zero-setting a X-axis display value on the counter.
- 14) **Y-axis fine feed wheel** : Used to finely move the cross-travel stage along the Y-axis direction.
- 15) **Y-axis coarse-feed wheel** : Used to quickly move the cross-travel stage along the Y-axis direction.
- 16) **Y-axis zero-set switch** : A switch for zero-setting a Y-axis display value on the counter.
- 17) **Swivel knob** (for MF- * 2017C, MF- * 3017C and MF- * 4020C) : Used to swivel the XY stage up to $\pm 5^\circ$ or $\pm 3^\circ$. (This knob is not provided for the MF- * 505C, MF- * 1010C and MF- * 2010C models.)

-
- 18) **Swivel clamp screw** (for MF- * 2017C, MF- * 3017C and MF- * 4020C) : Used to fix the XY stage up swiveled. (This screw is not provided for the MF- * 505C, MF- * 1010C and MF- * 2010C models.)
-

- NOTE**
1. Do not turn the swivel knob by force with the swivel clam screw tightened up. A trouble may result.
 2. If a workpiece and optional accessories are interfered with the swivel clamp screw, replace the swivel clamp screw with the button head screw which is the attachment.
-

1.2.3 Illuminator unit

- 19) **Control panel:** Consists of the switch to start the main unit and the knobs to control illumination and the aperture of transmitted illumination.

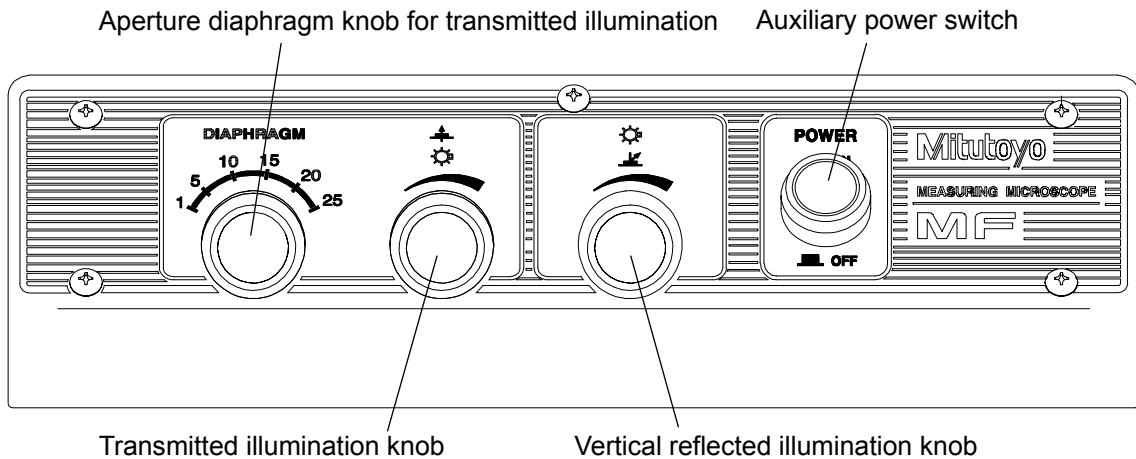

-
- TIP** **Aperture diaphragm:** A pencil of rays in the light system is controlled, which is associated with the resolving power, contrast, and focal depth of the optical system. Adjust the diaphragm to the optimal numerical aperture.
-

- NOTE**
1. For information about adjusting the aperture diaphragm, refer to the instructions given in "3.4 Adjusting the aperture for transmitted illumination".
 2. Even when the auxiliary power switch is turned off, feeble power is consumed.
If you do not use the product for a long time, please turn off the main power of the control unit.
-

- 20) **Vertical reflected illuminator (requisite selection option):** Lighting device for measurement of workpiece surface. According to your choice, either the LED illuminator or halogen illuminator is placed.
- For the LED illuminator, plug into the connector that indicates "SURFACE" on the rear panel. Two filters can be attached to the illuminator.

- For the halogen illuminator, plug into the connector that indicates “SURFACE” of the illuminator (control unit). Two filters can be attached to the illuminator.
- 21) **Transmitted illuminator (requisite selection option):** Lighting device for measurement of workpiece contour. According to your choice, either the LED illuminator or halogen illuminator is placed.
- For the LED illuminator, plug into the connector that indicates “CONTOUR” on the rear panel. Two filters can be attached to the illuminator.
 - For the halogen illuminator, plug into the connector that indicates “CONTOUR” of the illuminator (control unit). Two filters can be attached to the illuminator.

-
- NOTE**
1. For information about replacing halogen bulbs, refer to the instructions given in "4.3.1 Replacing halogen bulbs".
 2. For information about replacing LED bulbs, refer to the instructions given in "4.3.2 Replacing LED bulbs".
-

- 22) **Rear panel:** Consists of the connectors to be connected to the control unit, transmitted illuminator, and reflected illuminator.

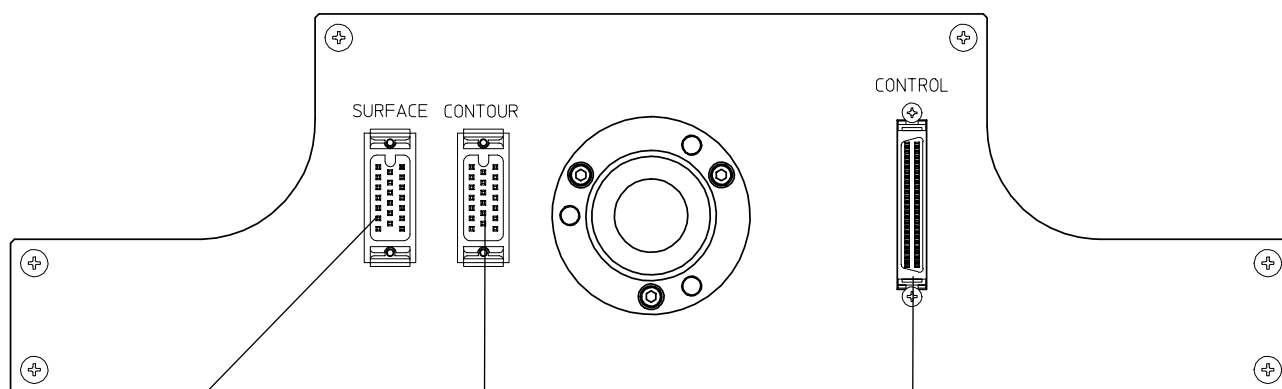

b) Connector for vertical reflected illuminator (LED)

c) Connector for transmitted illuminator (LED)

a) Connector for control cable

a) Connector for control cable

This connector is used to connect this unit and the cable connected to the control unit.

b) Connector for vertical reflected illuminator (LED)

This connector is used to connect an LED type vertical reflected illuminator. (To connect a halogen type vertical reflected illuminator, this connector is not used.)

c) Connector for transmitted illuminator (LED)

This connector is used to connect an LED type transmitted illuminator. (To connect a halogen type transmitted illuminator, this connector is not used.)

1.2.4 DRO counter unit

23) **Counter** : The displacement of cross-travel stage and optical tube unit is displayed on this counter.

① Front view of the counter

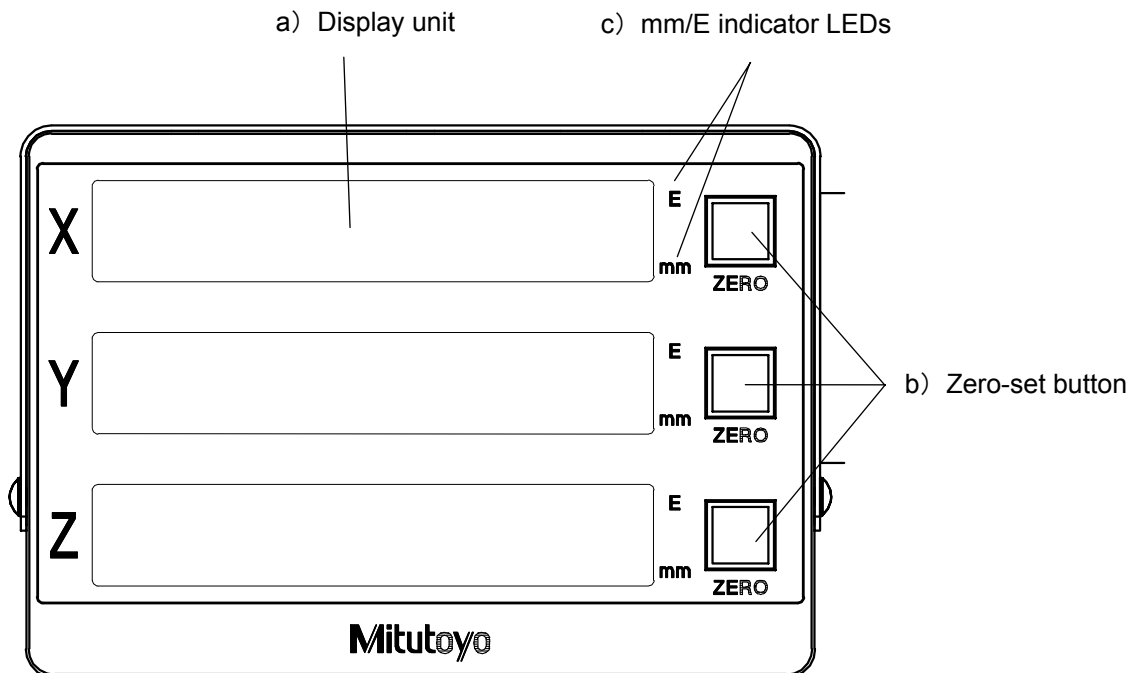

a) Display unit

Displays the displacement of cross-travel stage and optical tube.

Resolution: 0.001/0.0005/0.0001mm (.0001/.00005/.00001") (switchable)

b) Zero-set button

Zeroes the display value at any position.

Pressing the button makes the buzzer sound.

c) mm/E or indicator LEDs

Indicates the unit (mm or E) currently used.

A value in units of E is displayed by dividing a displacement in units of mm by 25.4.

②Rear view of the counter

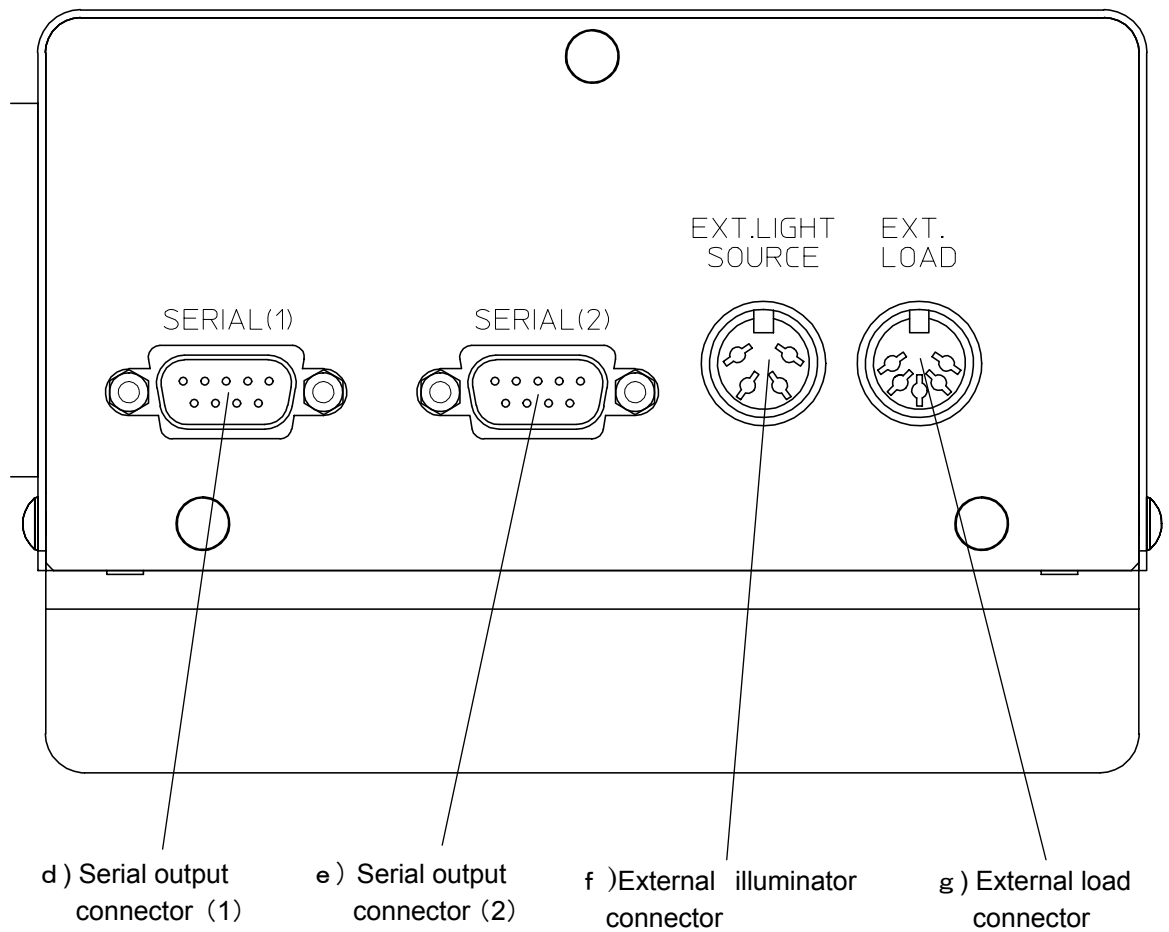

d) **Serial output connector (1)**

Connects to data processing devices such as the vision unit or QM-Data200

e) **Serial output connector (2)**

Connects to Vision unit

f) **External illumination connector**

This connector is used to connect an external lighting source from the optional accessories (LED ring illuminator/twin fiber illuminator/ring fiber illuminator).

g) **External load connector**

Connects to external load switch

About parameters

To actually perform measurement, it is necessary to set up the count direction (count-up or count-down direction), resolution, etc. This subsection describes the function and setting procedure of each parameter.

(1) Function

Some parameters are effective for all axes and other parameters are necessary to be set for each axis. **All axes** is described for the parameters that are effective for all axes and **Individual axis** is described for the parameters to be set for each axis, respectively, in the Setting column of the following table.

No.	Parameter function	Setting
F 0 1	Display unit [mm/E (inch)] setup	All axes Each time the Y-axis zero-set button on the counter is pressed, the count unit display LED [mm] or [E] is selected (lit) alternately.
F 0 2 - 1	Count direction of X-axis (count-up or count-down direction) setup	Individual axis Each time the Y-axis zero-set button on the counter is pressed, the display of [UP] or [dn] is selected (displayed) alternately and the count direction is switched.
F 0 2 - 2	Count direction of Y-axis (count-up or count-down direction) setup	
F 0 2 - 3	Count direction of Z-axis (count-up or count-down direction) setup	
F 0 3	Resolution setup	All axes 0.1 : Minimum readout of 0.1 μ m/0.00001" 0.5 : Minimum readout of 0.5 μ m/0.00005" 1.0 : Minimum readout of 1 μ m/0.0001"
F 0 5	Setup for the number of smoothing times (Smoothing : Function to decrease the flicker of the counter by averaging detected values which is done sampling, if it is difficult to read the least significant digit due to the flicker caused by vibration of the installation site.)	All axes 1 : One time of sampling 8 : 8 times of sampling 16 : 16 times of sampling 32 : 32 times of sampling

NOTE No. F05 parameter has no function to keep measuring accuracy if vibration occurred in the microscope installation site. It is able to decrease the flicker of counter; however, the measuring accuracy of microscope fails according to the volume of vibration in the installation site.

No.	Parameter function	Setting
F 0 7 - 1	RS-232C communication condition setup [Baud rate]	1 2 0 0 b P S : 1200 bps 2 4 0 0 b P S : 2400 bps 4 8 0 0 b P S : 4800 bps 9 6 0 0 b P S : 9600 bps 1 9 2 0 0 b P S : 19200 bps
F 0 7 - 2	RS-232C communication condition setup [Data length]	7 b : 7 bits 8 b : 8 bits
F 0 7 - 3	RS-232C communication condition setup [Parity]	n o n : None E n : Even o d d : Odd
F 0 7 - 4	RS-232C communication condition setup [Stop bit]	1 b : 1 bit 2 b : 2 bits
F 0 7 - 5	RS-232C communication condition setup [Flow control (Xon/Xoff)]	o n : (Xon/Xoff) enabled O F F : (Xon/Xoff) disabled
F 0 8	Setup for the number of output axes (Sets the serial output to either two-axis of X and Y or three-axis of X, Y, and Z, when the counter is three axes specification.)	2 A S : 2 axes 3 A S : 3 axes
F 0 9	RS-232C output format setup (Sets RS-232C data to the output format of Mitutoyo Vision unit or QM-Data200)	1 : Standard use 2 : Special use
F 1 0	Setup for the illumination energy saving function ※Refer to NOTICE 2 (Automatically turn off the illumination while not operating the microscope.)	0 : None 10 : Automatically turn off the light 10 minutes later 30 : Automatically turn off the light 30 minutes later
F 1 1	Setup for the volume of zero-set button (Pressing the zero-set button makes the buzzer sound.)	0 : None 1 : Volume level 1 (minimum) 2 : Volume level 2 3 : Volume level 3 4 : Volume level 4 5 : Volume level 5 (maximum)

- NOTE**
1. Use the setting "1" at No. F09 parameter. The setting "2" is the special use.
 2. Use No. F10 parameter with the setting "0". This function works only when the Vision Unit (option) is equipped. It does not work for the microscope which is not equipped with the Vision Unit.

(2) Parameter setting procedure

Parameter starting and exiting procedure

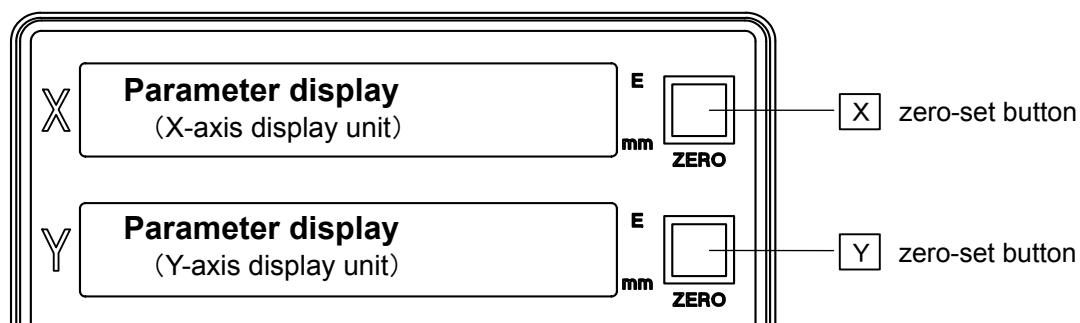

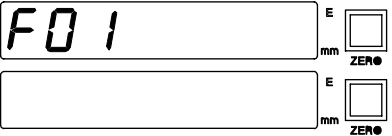
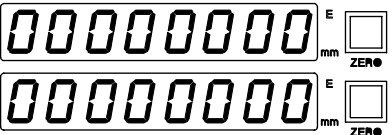
Parameter setup example	Button operation	Counter display	Operating procedure
① Starting the parameter setup mode	<input type="checkbox"/> X + <input type="checkbox"/> Y + Power switch		Turn on the power switch of microscope main unit while pressing the X-axis and Y-axis zero-set buttons at the same time.
② Switching parameters	<input type="checkbox"/> X	F 0 1 → F 0 2 - 1 → F 1 1 → F 0 1 →	Each time the X-axis zero-set button is pressed, the parameter display changes to the next in incremental order. The parameters are looped.
③ Switching parameter settings	<input type="checkbox"/> Y	0 . 1 → 0 . 5 → 1 . 0 → 0 . 1 (For a resolution)	Each time the Y-axis zero-set button is pressed, the parameter setting changes to the next. The parameter settings are looped.
④ Exiting the parameter setup mode (Loading the set content)	<input type="checkbox"/> X + <input type="checkbox"/> Y		Keep pressing the X-axis and Y-axis zero-set buttons at the same time for more than 3 seconds.

(3) Parameter setting operation examples

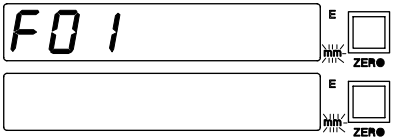
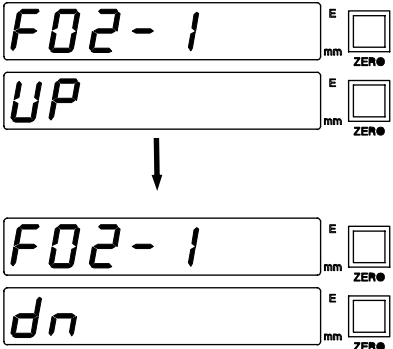
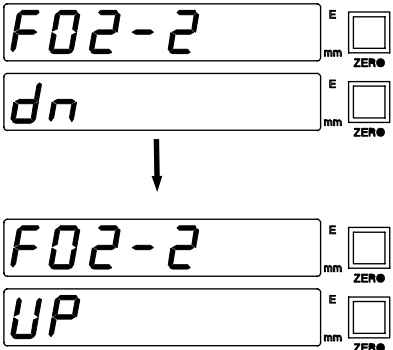
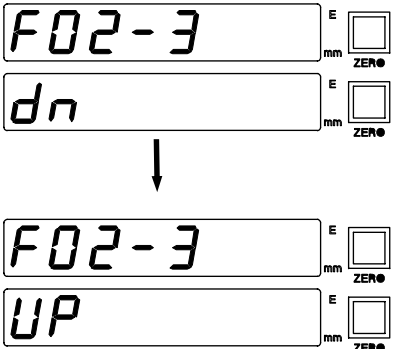
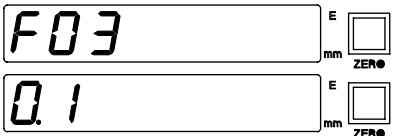
Parameter setup example	Button operation	Counter display	Operating procedure
Setting the display unit (Select "mm")	X Y		<ol style="list-style-type: none"> 1. Press the X-axis zero-set button to select parameter [F01]. 2. Press the Y-axis zero-set button to select [mm].
Setting the count direction (Reverse the count direction of X-axis)	X Y		<ol style="list-style-type: none"> 1. Press the X-axis zero-set button to select parameter [F02-1]. 2. Press the Y-axis zero-set button to select the setting (here [dn]) unlike the present setting (here [UP]).
Setting the count direction (Reverse the count direction of Y-axis)	X Y		<ol style="list-style-type: none"> 1. Press the X-axis zero-set button to select parameter [F02-2]. 2. Press the Y-axis zero-set button to select the setting (here [UP]) unlike the present setting (here [dn]).
Setting the count direction (Reverse the count direction of Z-axis)	X Y		<ol style="list-style-type: none"> 1. Press the X-axis zero-set button to select parameter [F02-3]. 2. Press the Y-axis zero-set button to select the setting (here [UP]) unlike the present setting (here [dn]).
Setting a Resolution (Select "0.1μm")	X Y		<ol style="list-style-type: none"> 1. Press the X-axis zero-set button to select parameter [F03]. 2. Press the Y-axis zero-set button to select [0.1].

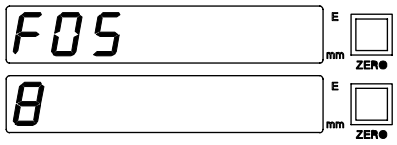
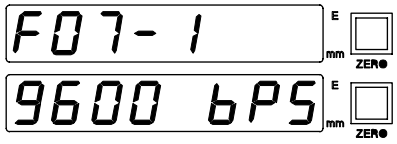
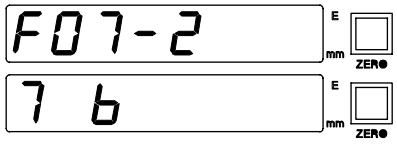
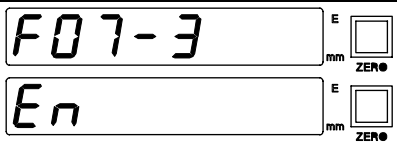
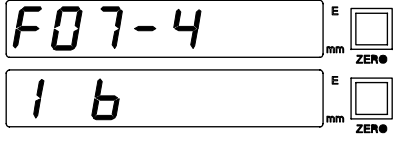
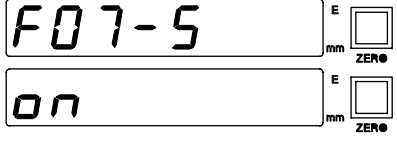
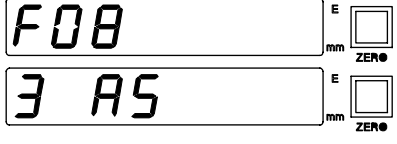
Parameter setup example	Button operation	Counter display	Operating procedure
Setting the number of smoothing times (Select 8 times of smoothing)	<input type="checkbox"/> X <input type="checkbox"/> Y		1. Press the X-axis zero-set button to select parameter [F05]. 2. Press the Y-axis zero-set button to select [8].
Setting the RS-232C Communication condition (Select a baud rate of 9600bps)	<input type="checkbox"/> X <input type="checkbox"/> Y		1. Press the X-axis zero-set button to select parameter [F07-1]. 2. Press the Y-axis zero-set button to select [9600 bPS].
Setting the RS-232C Communication condition (Select a data length of 7 bits)	<input type="checkbox"/> X <input type="checkbox"/> Y		1. Press the X-axis zero-set button to select parameter [F07-2]. 2. Press the Y-axis zero-set button to select [7 b].
Setting the RS-232C communication condition (Select the even parity)	<input type="checkbox"/> X <input type="checkbox"/> Y		1. Press the X-axis zero-set button to select parameter [F07-3]. 2. Press the Y-axis zero-set button to select [En].
Setting the RS-232C Communication condition (Select one stop bit)	<input type="checkbox"/> X <input type="checkbox"/> Y		1. Press the X-axis zero-set button to select parameter [F07-4]. 2. Press the Y-axis zero-set button to select [1 b].
Setting the RS-232C Communication condition (Select the flow control of enabled Xon/Xoff)	<input type="checkbox"/> X <input type="checkbox"/> Y		1. Press the X-axis zero-set button to select parameter [F07-5]. 2. Press the Y-axis zero-set button to select [on].
Setting the number of output axes (Select 3 axes)	<input type="checkbox"/> X <input type="checkbox"/> Y		1. Press the X-axis zero-set button to select parameter [F08]. 2. Press the Y-axis zero-set button to select [3 AS].

1.2.5 Illuminator unit

- 24) **LED control unit:** Controls the lighting of the LED illuminator.
- 25) **Halogen control unit:** Controls the lighting of the halogen illuminator.

① Front panel of control unit (common to LED/halogen)

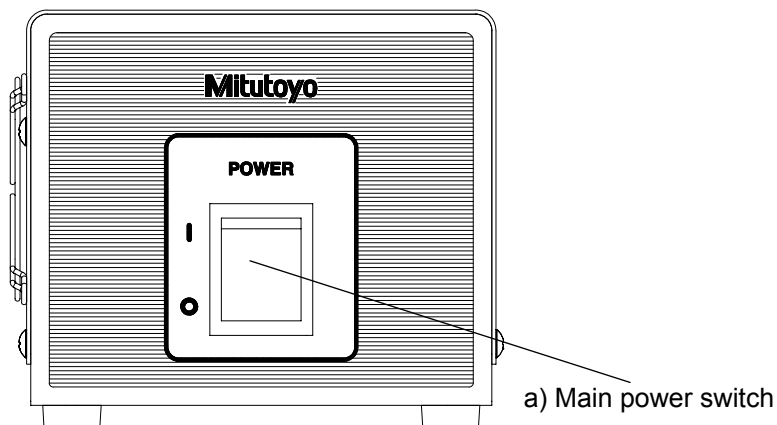

a) **Main power switch**

This switch is used to supply power to the whole system.

NOTE To shut off the power completely, turn off the main power switch.

② Rear panel of control unit

○ LED control unit

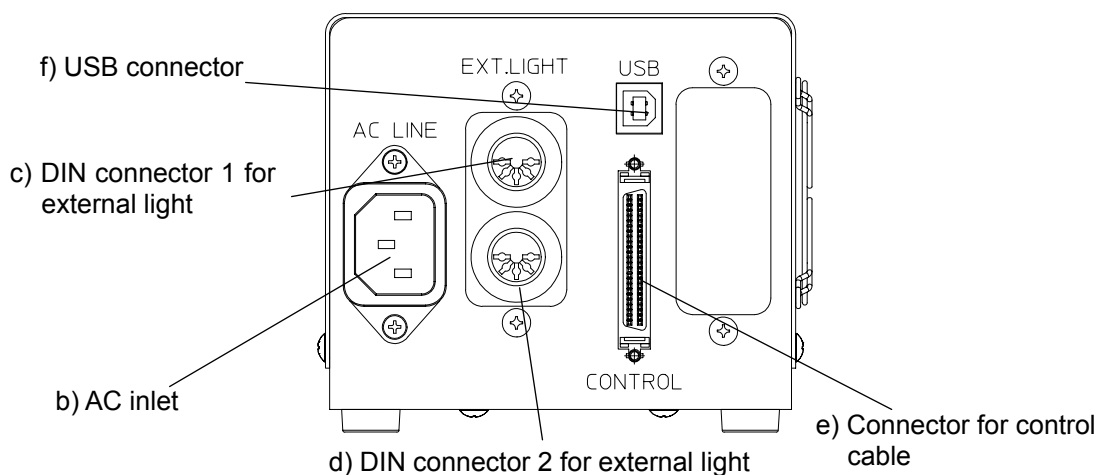

○ Halogen control unit

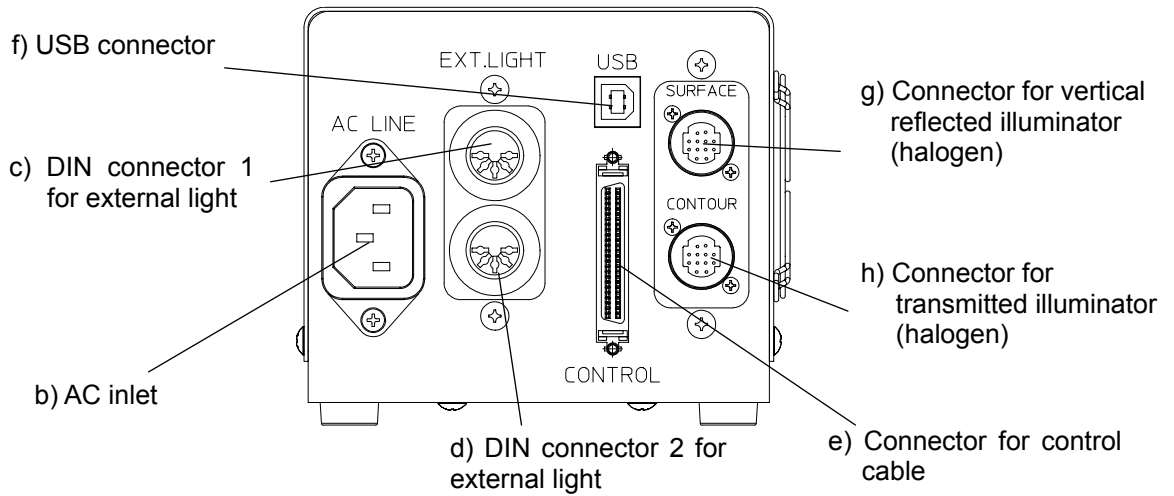

b) AC inlet

Connect the power cord.

c) DIN connector 1 for external light

This connector is not used.

d) DIN connector 2 for external light

This connector is not used.

e) Connector for control cable

This connector is used to connect this unit and the cable connected to the control unit.

f) USB connector

This connector is not used.

g) Connector for vertical reflected illuminator (halogen)

This connector is used to connect a halogen type transmitted illuminator.

h) Connector for transmitted illuminator (halogen)

This connector is used to connect a halogen type transmitted illuminator.

2

Installation and Setup

This chapter describes the installation environments and connection method of the MF series Measuring Microscope.

2.1 Installation

Although the weight varies depending on the models, this machine is quite heavy (approx. 65.5~140kg). Mitutoyo handles and sets up the machine, because it is necessary to confirm and adjust the accuracy after installation.

NOTE On the Reinstallation.....The microscope main unit reinstallation performed on the client's own may deteriorate the required accuracy due to vibrations and shocks during transportation. Therefore, it is recommended that the main unit be reinstalled by Mitutoyo. If the system is desired to be reinstalled, be sure to contact the Mitutoyo sales office.

2.2 Remove the Fixing Plate

Remove the fixing plates for cross-travel stage and optical tube unit after installing the main unit.

2.2.1 Removing the fixing plate for cross-travel stage

Remove eight pieces of fixing plate (one piece for MF- * 505C, MF- * 1010C, and MF- * 2010C) from the XY stage. (Use a 3mm Allen wrench.)

- ① For MF- * 2017C, MF- * 3017C, and MF- * 4020C

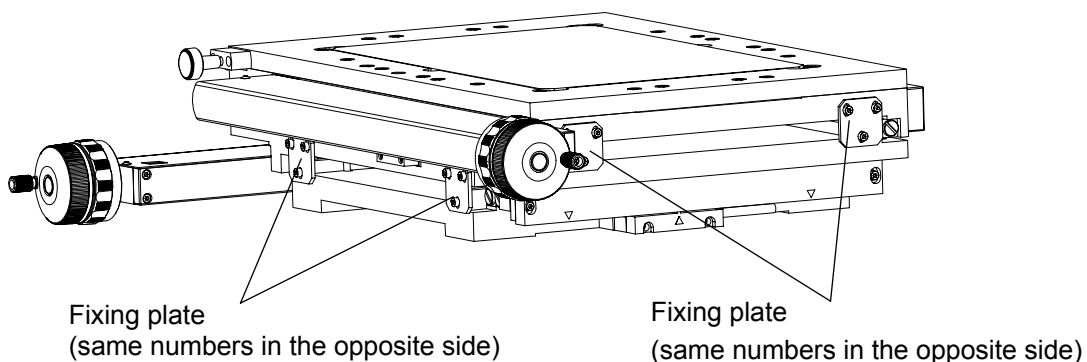

- ② For MF- * 505C, MF- * 1010C, and MF- * 2010C

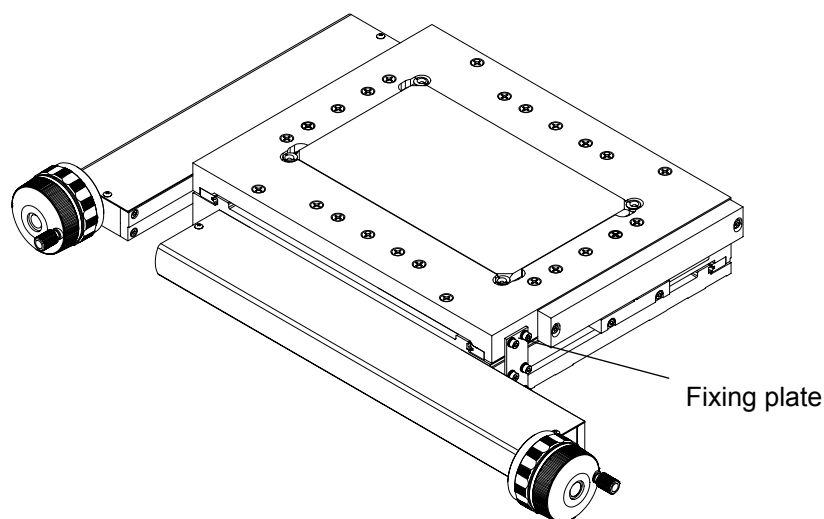

2.2.2 Removing the fixing plate for optical tube unit

Remove a fixing plate from the optical tube unit. (Use a 3mm Allen wrench.)

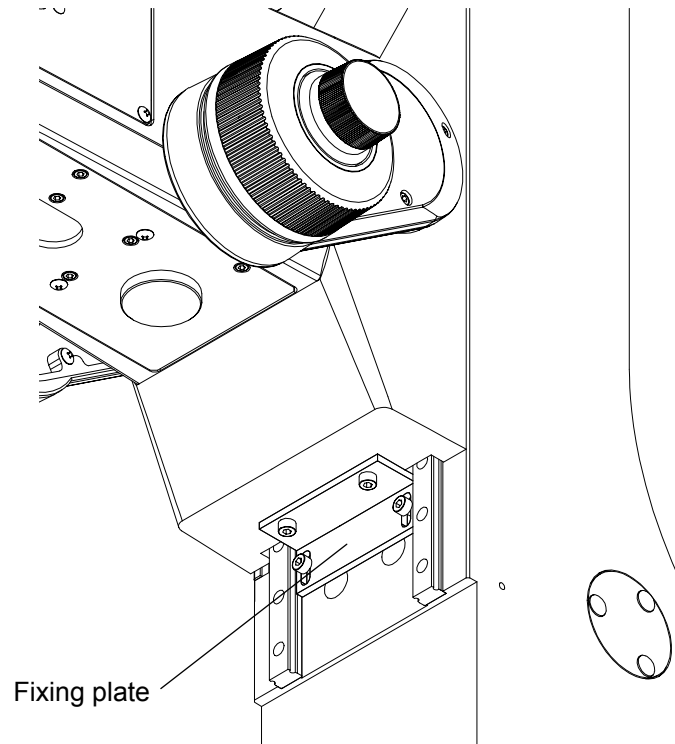

2.3 Moving the Table on the Cross-Travel Stage

Check the operation of the table and optical tube unit (see the next section) according to the following procedure. Moving the table and optical tube unit is the basic operation for performing measurement. Sufficiently understand the operation of these units and familiarize yourself with it.

2.3.1 When a great and quick travel of the table is required

This operation is required to roughly position a work piece or quickly escape it.

- ① Turn the coarse-feed wheel clockwise when viewed from the fine-feed wheel side to unlock the table.
- ② Hold the coarse-feed wheel until the table moves to the required position.
- ③ Turn the wheel counterclockwise to lock the table.

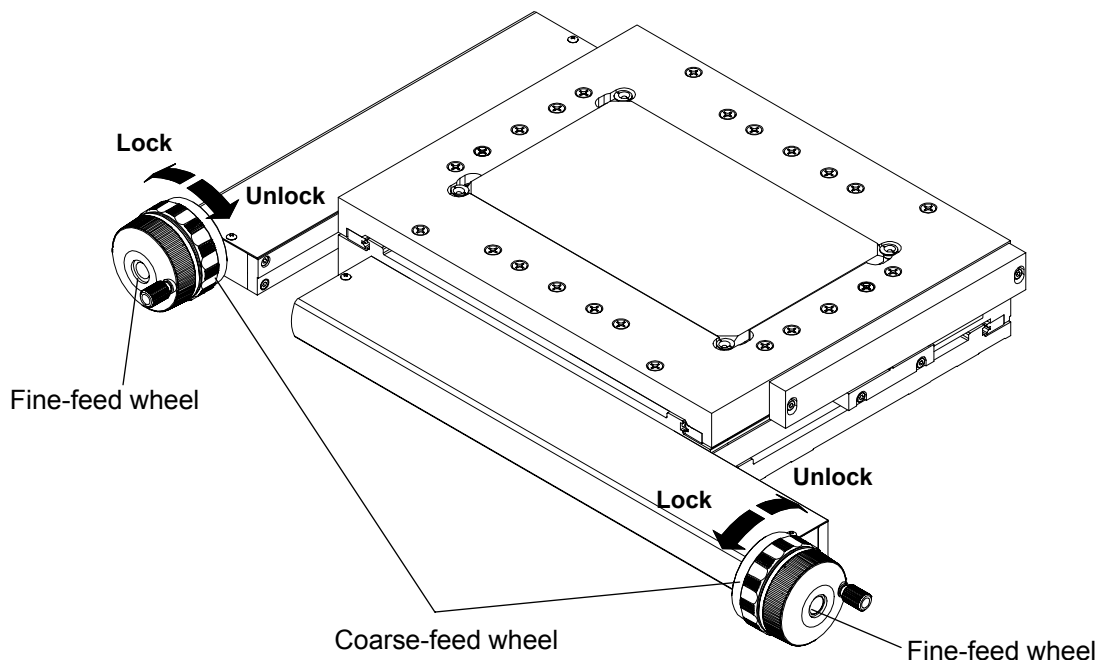

IMPORTANT When moving the table, do not make the impact on the stopper of stroke end. If the stroke end stopper is hit, the accuracy may decrease.

2.3.2 When a fine travel of the table is required

Turn the fine-feed wheel until the table moves to the required position. The table moves 1mm per full rotation of the wheel.

This operation is necessary for final positioning of a work piece.

IMPORTANT When reached the stroke end, do not turn the fine-feed wheel any more. Turning the wheel by force may prevent the smooth operation.

2.4 Moving the Optical Tube Unit

2.4.1 When a great and quick travel of the unit is required

Turn the coarse-feed wheel with a large diameter until the optical tube unit moves to the required height. The unit moves 30mm per full rotation of the wheel. This operation is required to roughly focus the optical tube or quickly escape it.

2.4.2 When a fine travel of the unit is required

Turn the fine-feed wheel with a small diameter until the optical tube unit moves to the required height. The unit moves 0.2mm per full rotation of the wheel. This operation is necessary for final focusing of the optical tube.

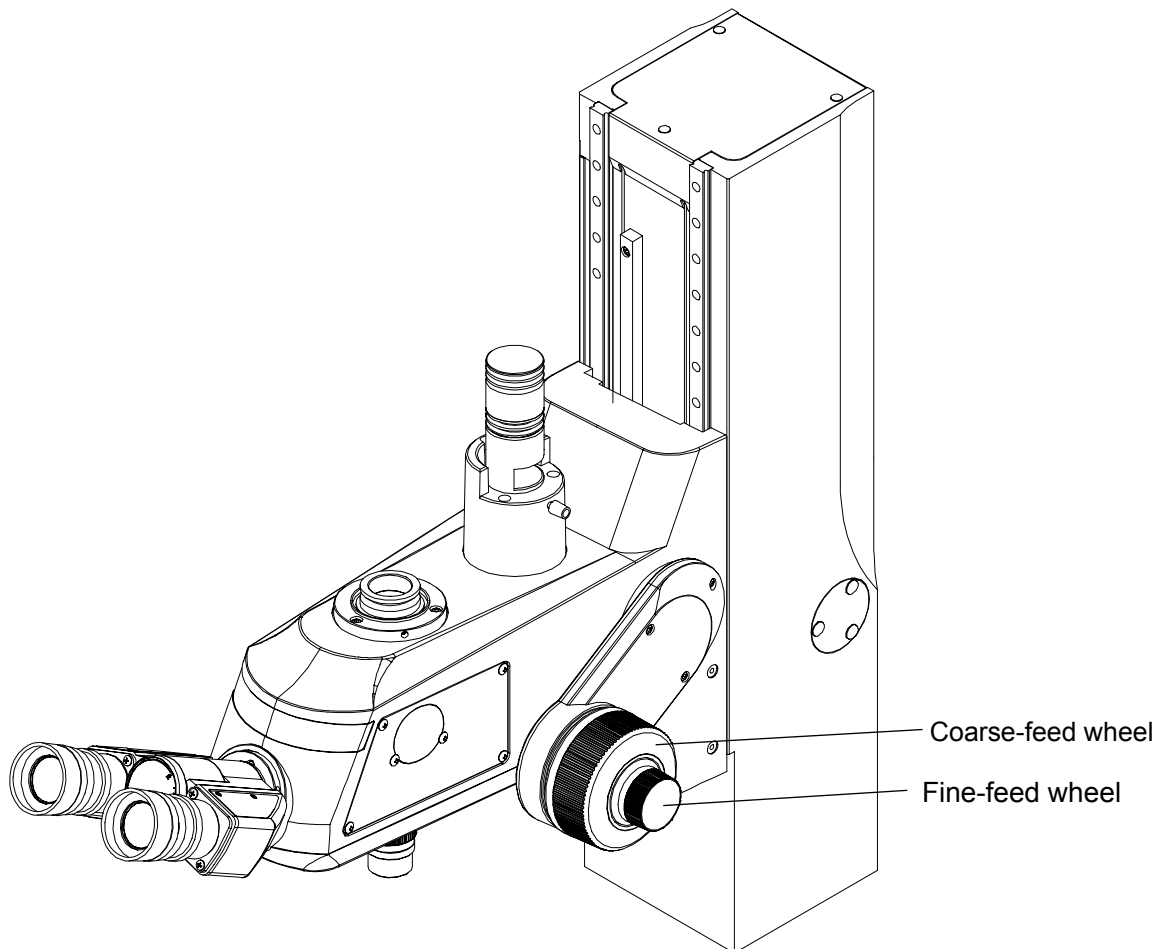

- NOTE**
1. Exercise sufficient care when the optical tube unit descends so as not to hit a work piece by lens or the optical tube unit.
 2. Do not turn both coarse-feed wheels simultaneously in the reverse direction.
 3. Do not turn the wheels any more when the tube unit has reached either stroke end.

There is a risk of damage to the internal feed mechanism in either case of above-mentioned 2 and 3.

2.5 Leveling the Main Unit

To level the main unit, perform the following procedure:

- ① Place the main unit on the dedicated table.

TIP Use a mounting stand (No.176-309) or a rigid stable stand.

If any annoying image waving is caused under high-magnification observation, use the vibration isolating stand (No.176-308).

- ② Turn five leveling screws (two pieces on both sides of the front bottom, two pieces on both sides of the rear bottom, one piece on rear center) to the direction that they are tightened up using a screwdriver, etc.. Especially tighten the two pieces on both sides of the rear bottom almost fully so that they may not interfere with the installation surface.
- ③ Place a level on the stage glass to level the main unit by three leveling screws (front two pieces, rear center one piece).
- ④ After leveling, turn the right and left screws of rear side until they touch the dedicated table slightly.

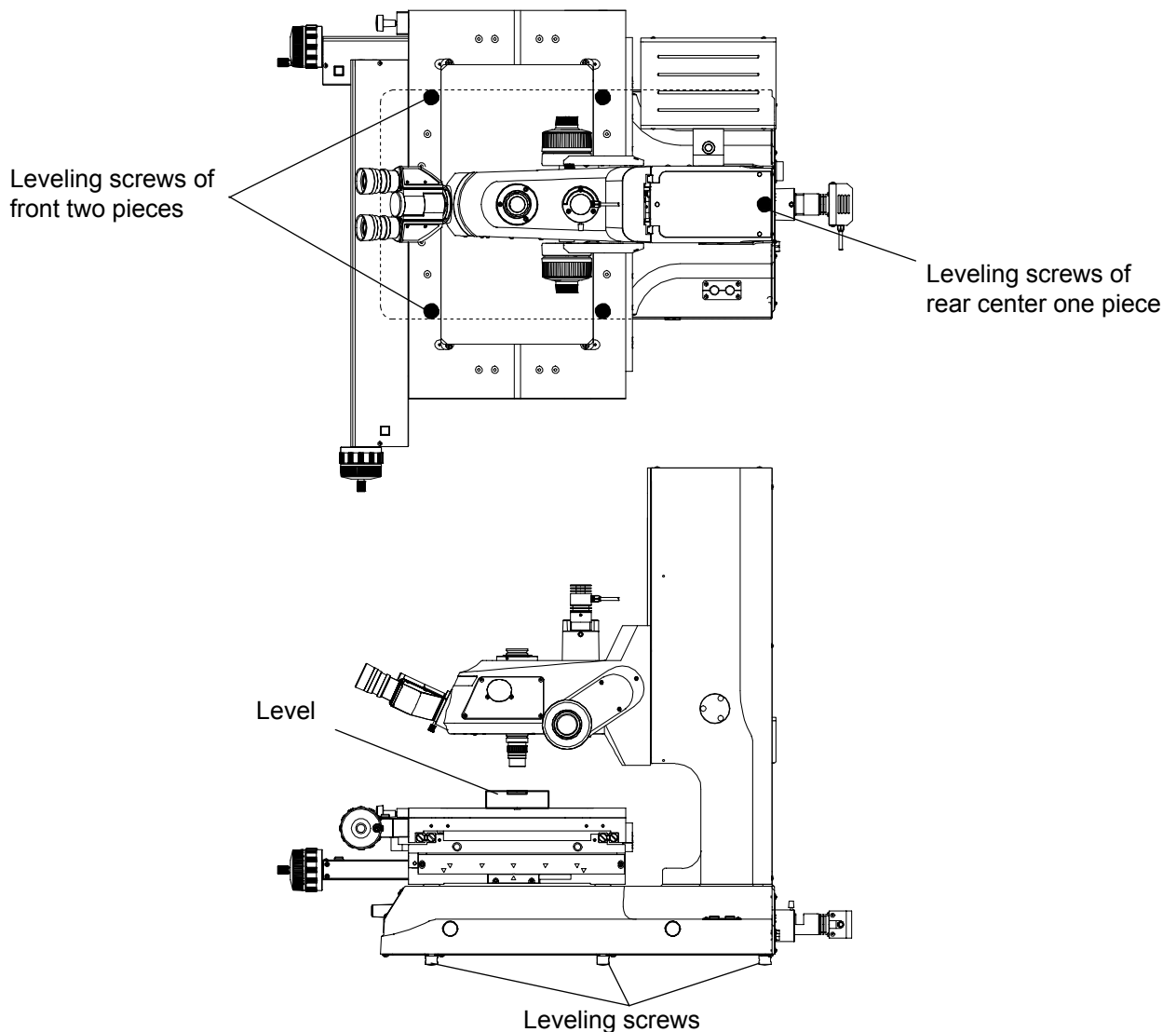

2.6 Mounting (Replacing) the Eyepiece Unit

Mount the eyepiece unit (a generic name for binocular or monocular unit, protractor eyepiece, etc.) selected from the optional accessories on the optical tube unit according to the following procedure:

2.6.1 Mounting the binocular unit

- ① Loosen the optical tube clamp screw while holding the eyepiece unit by hand, then dismount the eyepiece unit.
(This procedure is not required when setting up the main unit due the eyepiece unit is not mounted.)
- ② Loosen the optical tube clamp screw sufficiently to mount the binocular unit.
- ③ Mount the binocular unit on the optical tube unit, then tighten the optical tube clamp screw to secure the binocular unit.

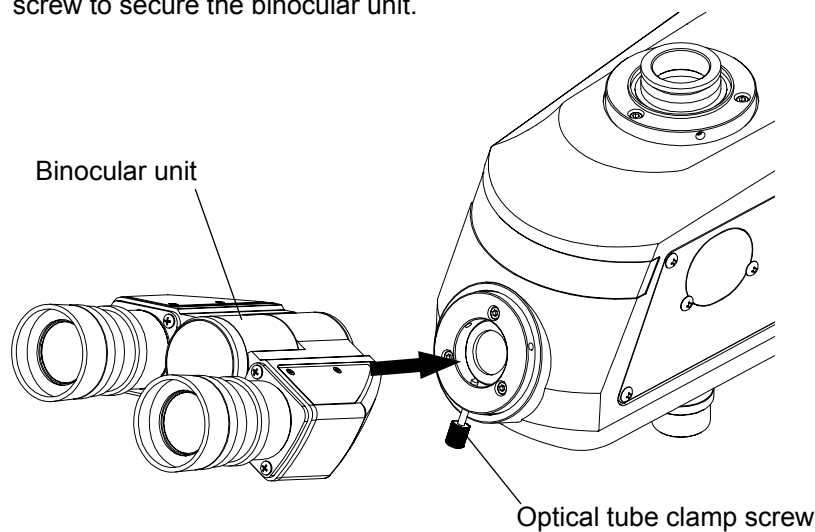

NOTE When attaching or detaching the eyepiece unit, be sure to tighten or loosen the clamp screw while holding the unit by hand.
If not, the unit may drop, possibly damaging the instrument, or a work piece.

2.6.2 Mounting the monocular unit

- ① Loosen the optical tube clamp screw while holding the eyepiece unit by hand, then dismount the eyepiece unit.
(This procedure is not required when setting up the main unit due the eyepiece unit is not mounted.)
- ② Loosen the optical tube clamp screw sufficiently to mount the monocular unit.
- ③ Mount the monocular unit on the optical tube unit, then tighten the optical tube clamp screw to secure the monocular unit.

2.6.3 Mounting other eyepiece unit (protractor eyepiece)

Mount the eyepiece unit following the same procedure as that for mounting the monocular unit.

2.7 Mounting the Lenses

Mount the objective and eyepieces according to the following procedure:

2.7.1 Mounting the objective

- ① Turn the coarse/fine focusing wheel to move the optical tube unit to a position where the objective can be easily mounted.
- ② Turn the objective clockwise (as viewed from the bottom) to fix it to the objective mount.

2.7.2 Mounting the eyepieces

2.7.2.1 For the binocular unit

Remove the cap from the eyepiece mount to mount the eyepieces.

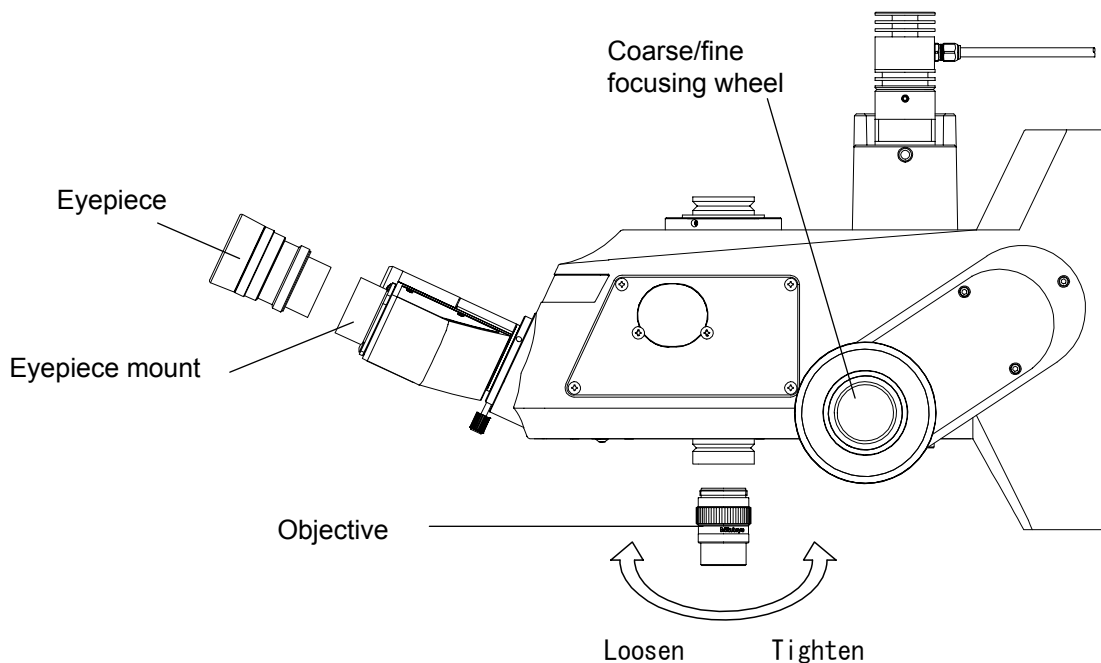

2.7.2.2 For the monocular unit

- ① Remove the cap from the eyepiece mount to loosen the eyepiece clamp screw.
- ② Insert the eyepiece and fix it by the clamp screw.

TIP Some optional eyepieces are supplied with a monocular optical tube (such as Protractor eyepiece, etc.). In this case, loosen the monocular tube clamp screw to remove the standard monocular tube and mount the optional eyepiece.

-
- IMPORTANT**
1. Do not touch the lens surface with fingers.
 2. Be careful not to drop the lens.
-

2.8 Installation of the Illuminators

Insert a transmitted illuminator and a vertical reflected illuminator into their respective mounts in the main unit to fix them with clamp screws according to the following figure. Set the cables so as not to touch the illuminators.

2.8.1 For LED illuminator

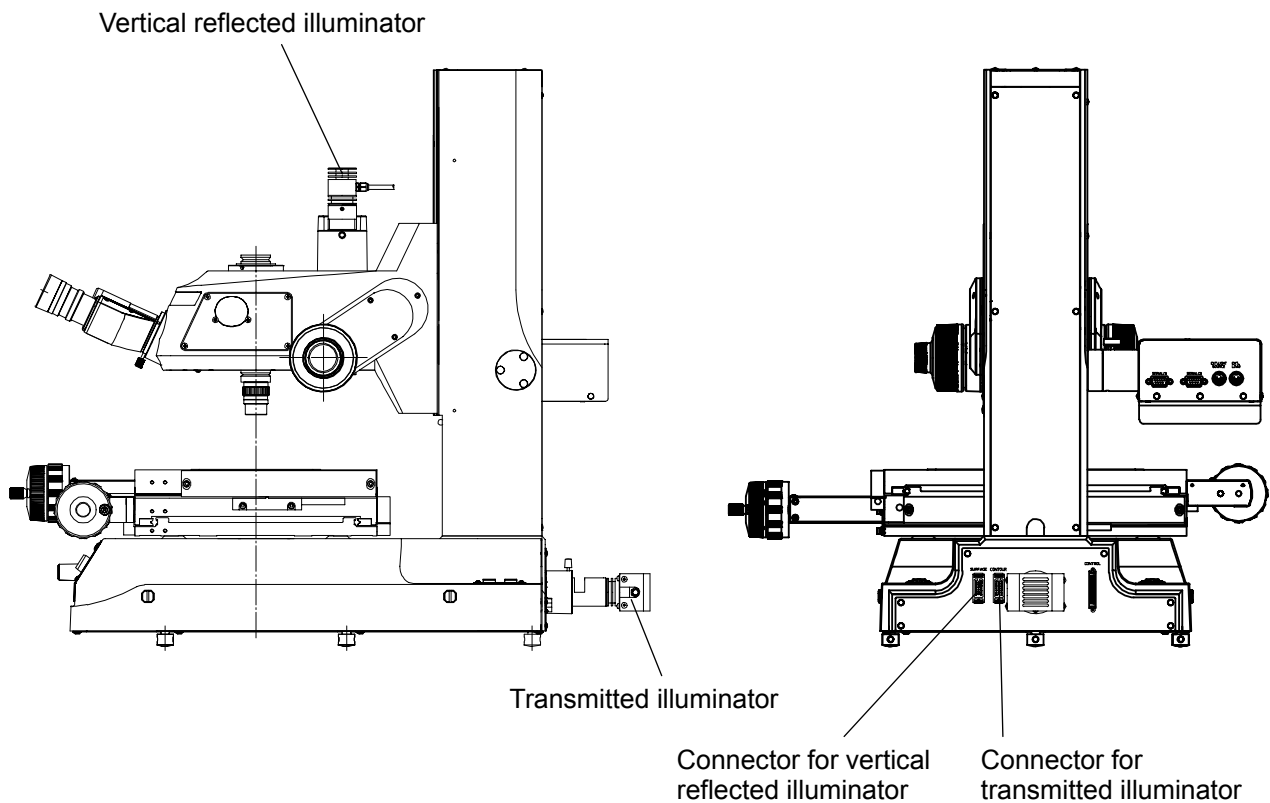

- IMPORTANT**
1. Do not turn on the light when the transmitted illuminator and vertical reflected illuminator are removed from the main unit. After turning on the illuminator, it becomes very hot. Do not illuminate upward, otherwise the cable will be deformed by the heat.
 2. Do not place anything on the illuminator and its peripheral part. The efficiency of the air-cooling fan decreases and a trouble will result.

2.8.2 For halogen illuminator

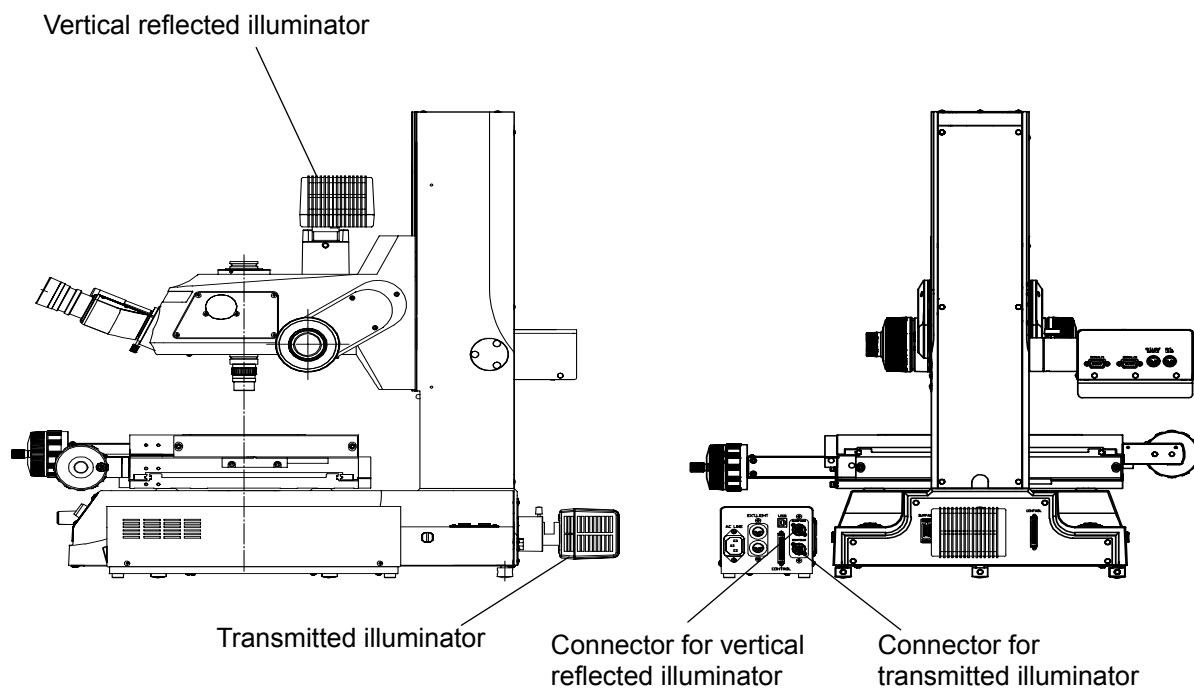

-
- IMPORTANT**
1. Do not turn on the light when the transmitted illuminator and vertical reflected illuminator are removed from the main unit. After turning on the illuminator, it becomes very hot. Do not illuminate upward, otherwise the cable will be deformed by the heat.
 2. Do not place anything on the illuminator and its peripheral part. The efficiency of the air-cooling fan decreases and a trouble will result.
-

2.9 Changing the Counter Mounting Angle and Position

This measuring microscope is packed with the counter mounted on the left side of the column as shown in the figure in "1.2 Name and Function of Each Part".

The counter rotates vertically in order to remove the adverse condition such that the counter display is difficult to view or the keys are not easy to operate. Loosen the clamp screw on the flange located between the counter and the column, rotate the counter to a desired angle, and then tighten the clamp screw.

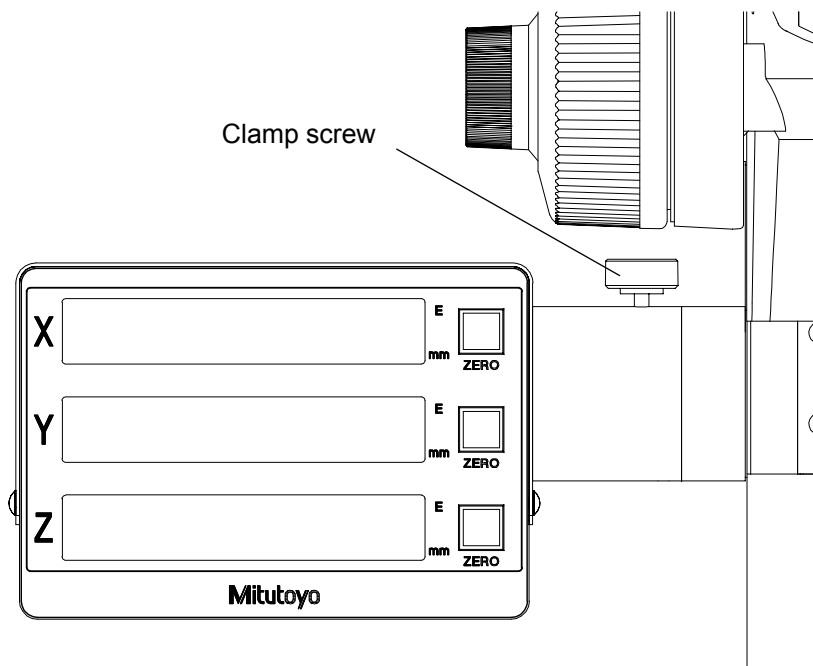

Also, the counter of this microscope is able to be mounted on the right side of the column to meet the client's needs for operability. If the client needs to change the counter mounting position to the right side of the column, contact the nearest Mitutoyo sales office.

2.10 Connecting Each Part

Connect the cables of each part according to the following figure:

- ① Connect the microscope main unit and control unit with the control cable.
- ② Plug the power cord into the control unit, then plug the power plug into the power outlet.

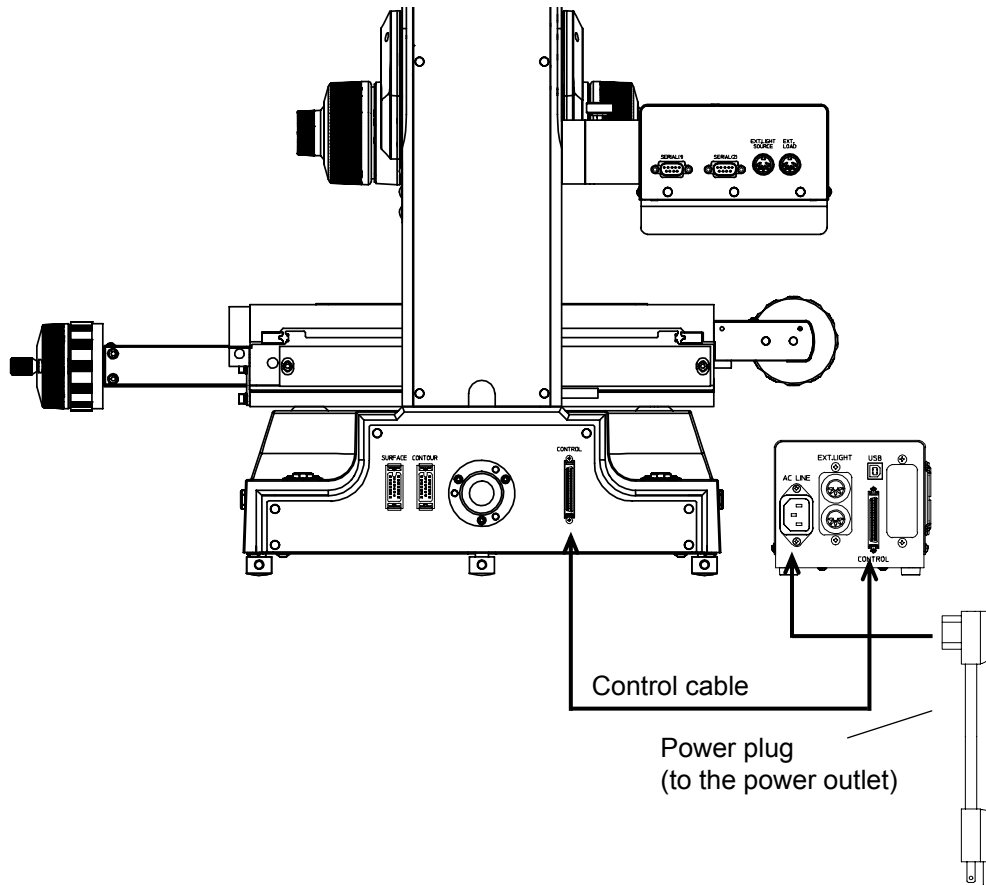

3

Measurement Setup

This chapter explains the setup for measurement including the optical system installation and workpiece set-up.

3.1 Connection Check

Check that all connecting cables have been connected properly as specified.

3.2 Turning the Power Supply On

Turn the power supply on according to the following procedure:

- ① Before turning the power switch on, turn the transmitted and vertical reflected illumination knobs on the control panel fully counterclockwise to minimize the light intensity.
- ② Turn on the power switch of control unit. (Switch to "I" position)
- ③ Turn the transmitted and vertical reflected illumination knobs clockwise to confirm that both illuminators light up.
- ④ Turn the transmitted and vertical reflected illumination knobs clockwise to confirm that both illuminators light up.

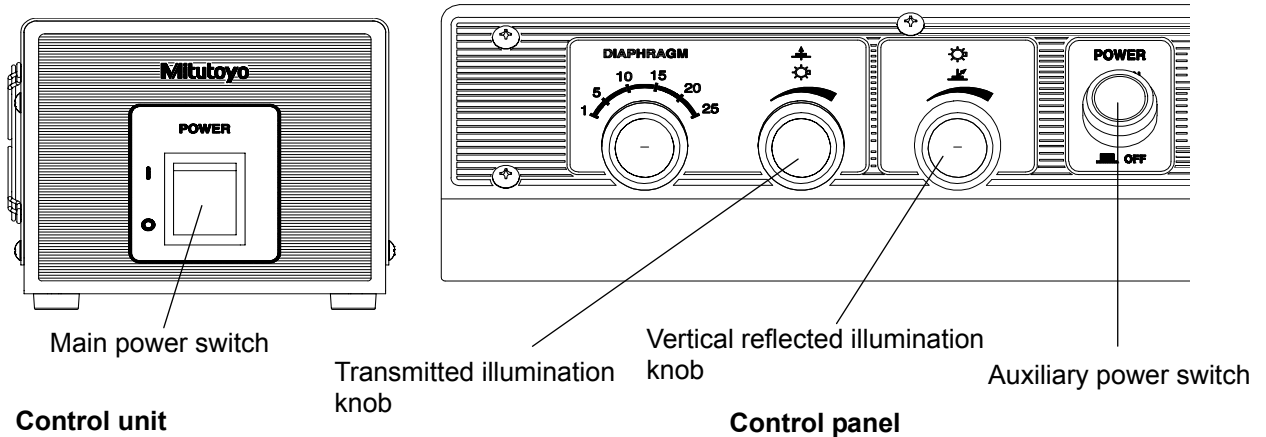

IMPORTANT The counter may display error messages (E51, E52, E53) due to the procedure for turning ON/OFF the power supply of the microscope main unit and the peripheral equipment such as PC in the connection with some peripheral equipment when the peripheral equipment is being connected with the counter unit at RS232C.

Be sure to perform at the following order when turning the power switch ON/OFF

- For ON Peripheral equipment → Microscope main unit
- For OFF Microscope main unit → Peripheral equipment

3.3 Confirming the Filament Position of the Halogen Illuminator

No centering a bulb is needed after replacing it. Confirm that the bulb is installed to the socket correctly.

(For information about replacing the bulb, refer to 4.3.1 “Replacing halogen bulbs”)

3.3.1 Confirming the filament position of the halogen vertical reflected illuminator

- ① Mount a low-magnification objective.
- ② Place a white paper on the stage.
- ③ Turn the light on by turning the vertical reflected illumination knob.
- ④ Bring the eyepiece into focus
- ⑤ Confirm that the illumination on the white paper is circle.
- ⑥ If the illuminated circle is not round or uniform intensity, the bulb is not installed correctly. Turn the power switch off, and insert the bulb all the way until it reaches the end of the socket after the bulb becomes cool.

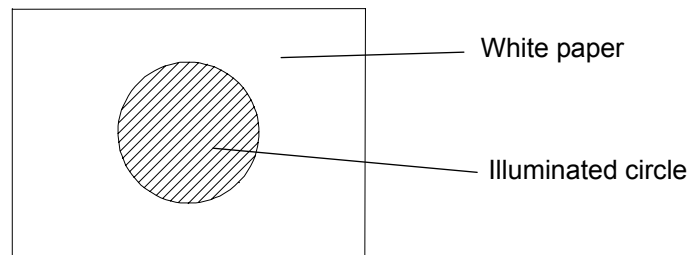

3.3.2 Confirming the filament position of the halogen transmitted illuminator

- ① Mount a low-magnification objective.
- ② Turn the light on by turning the transmitted illumination knob.
- ③ Fully open the aperture diaphragm for transmitted illumination.
- ④ Remove the eyepiece to look into the objective from the optical tube.
- ⑤ Confirm that the illumination projected on the objective is circle.
- ⑥ If the illuminated circle is not round or uniform intensity, the bulb is not installed correctly. Turn the power switch off, and insert the bulb all the way until it reaches the end of the socket after the bulb becomes cool.

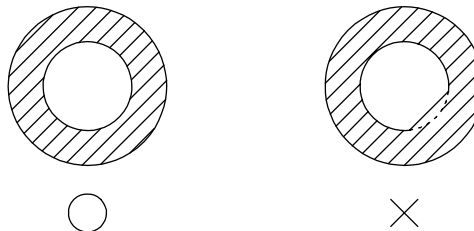

CAUTION

Right after the light is turned off, the bulb and its peripheral part are very hot. When cool enough to handle, replace the bulb carefully. (Wait for about 30 minutes as a guide.)

3.4 Adjusting the Aperture for Transmitted Illumination

The aperture diaphragm for transmitted illumination is used to adjust the Numerical Aperture (N.A) of transmitted illumination system. It controls the resolution, contrast, and depth of focus of the optical system.

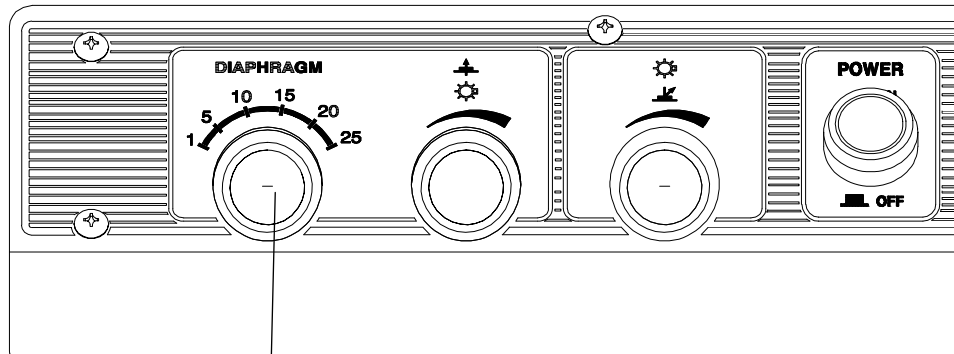

Aperture diaphragm knob for transmitted illumination

The diaphragm blades can be seen by removing the eyepiece and looking into the optical tube with an appropriate light intensity. Adjust the required aperture.

Aperture setting for obtaining a good contrast and image clarity for ordinary applications:

70 to 80% of radius

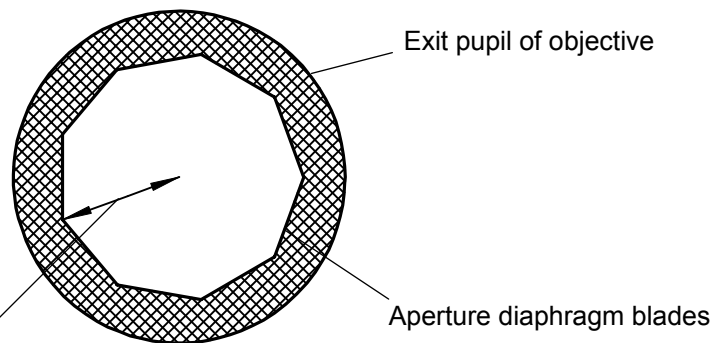

NOTE Do not set the aperture diaphragm less than 60% of the radius except for special types of workpieces. It reduces the resolution. To avoid diffraction, set the aperture diaphragm more than 15 except for special types of workpieces.

When measuring cylindrical workpieces or screw threads, the numerical aperture affects measurement accuracy. The appropriate optical aperture is shown as below:

(1) **For cylindrical measurement**

$$\begin{aligned} \text{Aperture } D &= 0.18F \sqrt[3]{\frac{1}{d}} \quad F ; \text{ Focal distance of condenser lens (mm)} \\ &= 19.224 \sqrt[3]{\frac{1}{d}} \end{aligned}$$

(2) **For screw thread measurement**

$$\text{Aperture } D = 19.224 \sqrt[3]{\frac{\sin \frac{\alpha}{2}}{d_2}}$$

D : Corresponds to the aperture setting 1 to 25 indicated on the aperture diaphragm knob on the control panel of the measuring unit.

d : Workpiece diameter

d₂ : Pitch diameter of screw thread

α : Screw thread angle

The following graph shows the correlation between the workpiece diameter d and the optimal aperture setting D. Adjust the aperture diaphragm knob to the optimal position by referring to this graph.

Aperture D (mm)

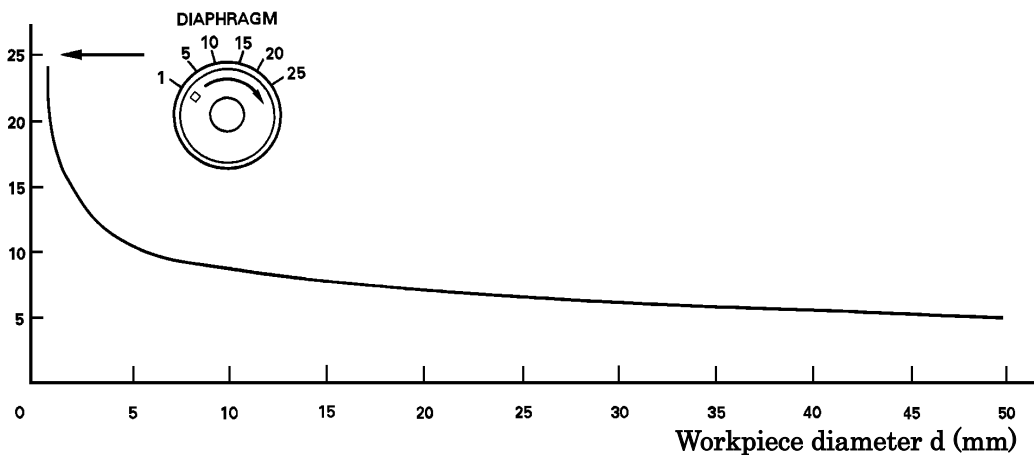

3.5 Adjusting the Aperture for Reflected Illumination

The aperture diaphragm for vertical reflected illumination is used to adjust the Numerical Aperture (N.A) of vertical reflected illumination system. It controls the resolution, contrast, and depth of focus of the optical system.

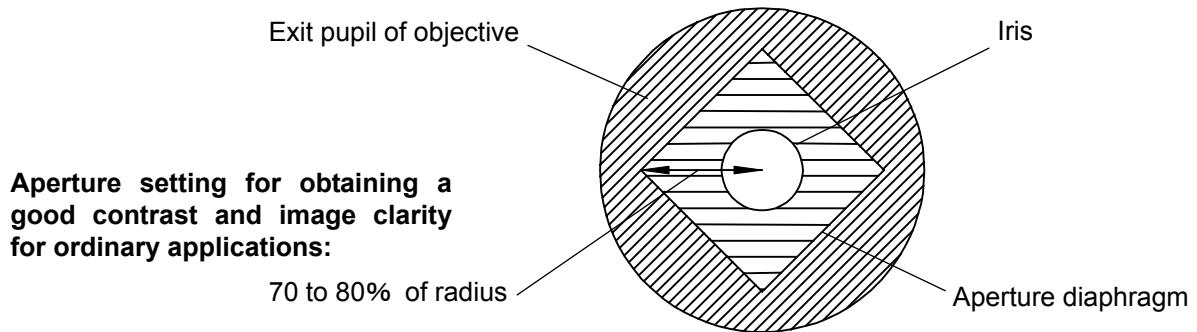

Confirm that the exit pupil of objective as above can be seen by removing the eyepiece and looking into the optical tube with an appropriate light intensity. Push and pull a knob of aperture diaphragm to adjust the numerical aperture.

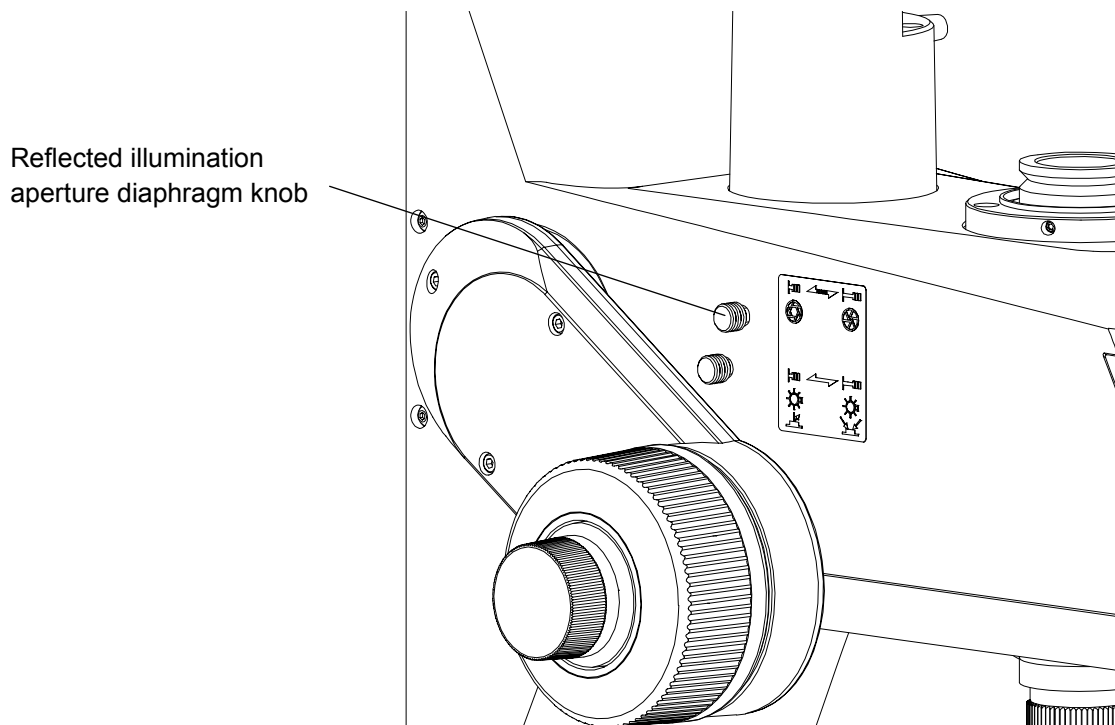

NOTE Do not set the aperture diaphragm less than 60% of the exit pupil radius except for special types of workpieces. This will reduce the resolution.

3.6 Setting Up a Workpiece

Place a workpiece as its surface to be measured (on the objective side) become at right angles to the optical axis of objective. The stage glass surface is at right angles to the optical axis of objective. If the workpiece surfaces are parallel, place the workpiece directly on the stage glass. If the surfaces are not parallel, adjust the measured surface to become at right angles to the optical axis with an appropriate fixture. Unless the measured surface is at right angles to the optical axis, it is impossible to focus the objective over the entire field of view.

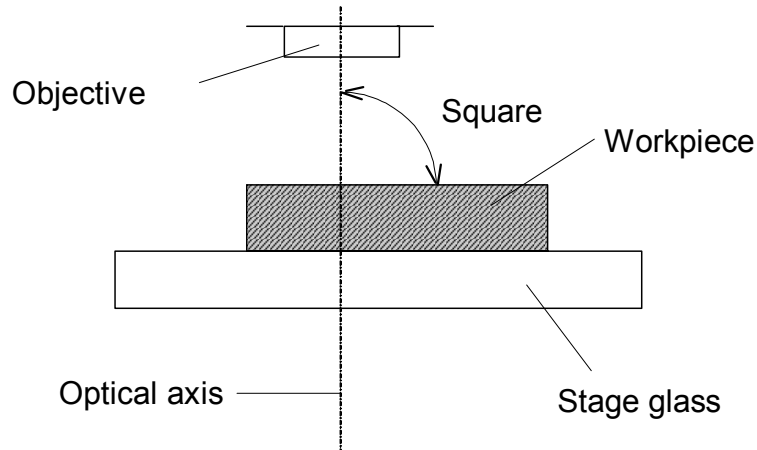

-
- NOTE**
1. A shock while setting up a workpiece may break the stage glass, resulting in damage and personal injury. Exercise care so as not to bump the measuring unit during setup.
 2. A workpiece that extends over the end of the XY stage can interfere with the main unit when the stage moves. Carefully mount the fixture on the stage.
 3. If a large size of cross-travel stage such as MF- * 2017C, MF- * 3017C, and MF- * 4020C is moved particularly rearward on the Y axis (toward the column), exercise care so that a workpiece or a fixture will not interfere with the main unit.
-

IMPORTANT Since the clamp is used only to prevent the workpiece from moving during measurement, there is no need for extensive joint strength. An excessive clamping force will deform a workpiece if it is made of thin or soft material, and a correct measurement result may not be obtained. Use a clamping method that will not deform the workpiece.

- TIP**
1. The swivel center support (No.172-197), V-block with clamp (No.172-378), and holder with clamp (No.176-107) are also available optionally to fix a workpiece.
 2. To secure a workpiece and fixture to the XY stage, use the tapped holes on the stage. The stage adapter (B)(No.176-310) is used for MF-* 2010C and the stage adapter (No.176-304) is used for MF-* 2017C, MF-* 3017C, and MF-* 4020C to be secured on the stage with tapped holes as shown below. The fixture is secured using T-groove of the adapter.

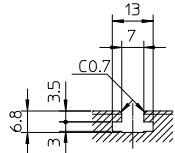

Stage adapter T-groove dimension figure

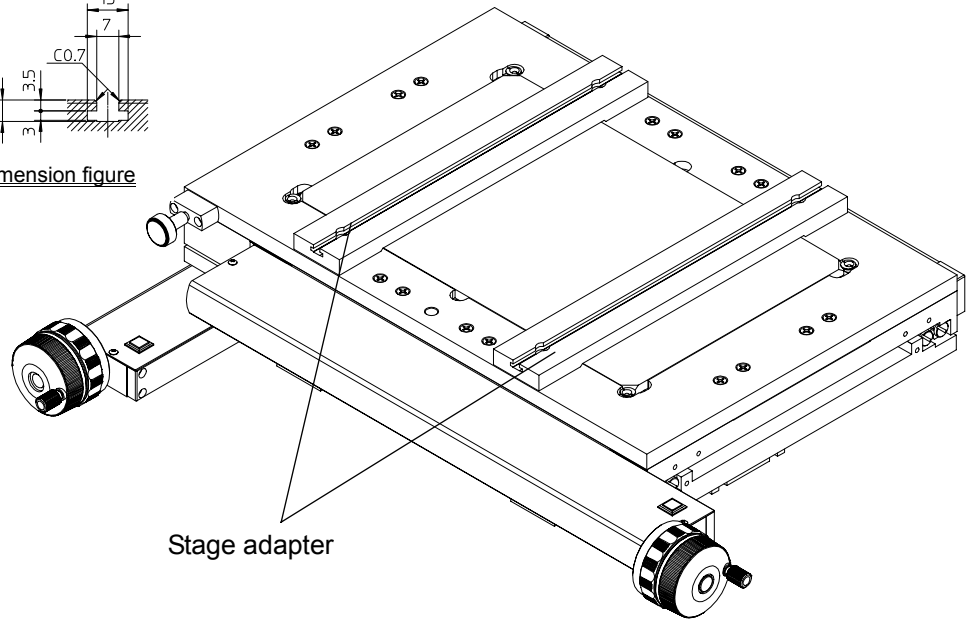

Stage adapter

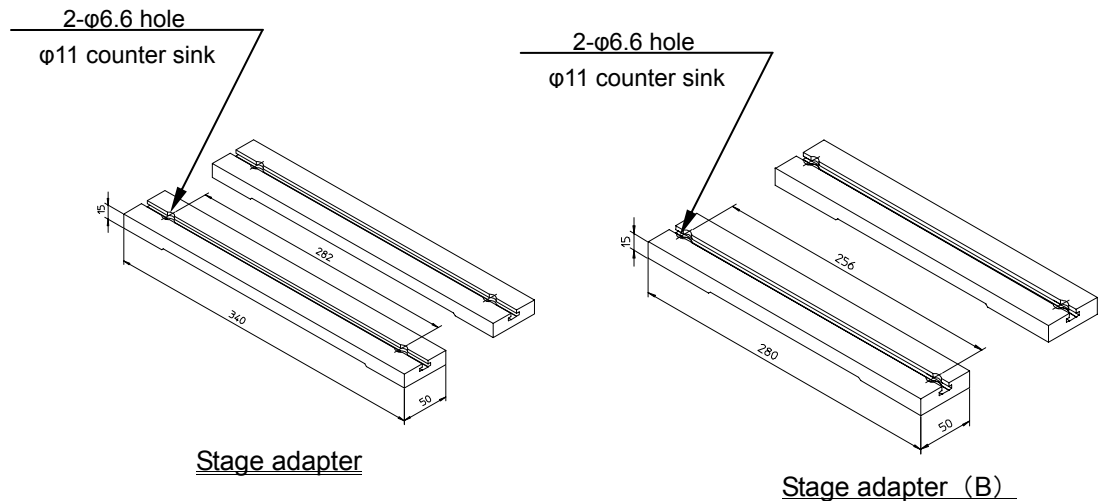

Stage adapter

Stage adapter (B)

Stage adapter dimension figure

3. For information about the dimensions of stages, refer to the XY stage in "6.8 External Dimensions".

3.7 Selecting the Illumination Method

Select the appropriate illumination method depending on the type of workpiece.

3.7.1 Transmitted illumination

Used for the contour measurement and inspection. A telecentric system ^(*1) is employed. The aperture diaphragm knob for transmitted illumination enables to adjust the brightness and obtain the optimal aperture when measuring cylindrical workpieces. There are continuous illumination intensity settings available. A maximum of two filters can be mounted.

TIP (*1) What is telecentric system? ····Illumination which placed the optical system so that the image center size may not change by the image growing faint, even if the focus deviates in the optic axis direction. The magnification error by the focusing does not occur.

3.7.2 Vertical reflected illumination

Used for surface measurement and inspection. (The surface should not be excessively rough). A Koehler system ^(*2) is employed and its advantages are fully utilized when measuring the surface of mirror finish workpiece.

TIP (*2) What is Koehler system? ····Illumination which placed the optical system so that the illumination light (image) is not directly imaged on the observation plane and the whole observation range is evenly irradiated by the uniform parallel light with high brightness.

3.7.3 Simultaneous use of transmitted and vertical reflected illumination

The transmitted and vertical reflected illumination modes or the transmitted and oblique reflected illumination modes can be used simultaneously. This enables to measure the contour and surface feature of workpiece at the same time.

3.7.4 Oblique reflected illumination (Optional oblique reflected illuminator is required)

Used for for measurement and inspection of workpiece surfaces which are not smooth. Since this method forms a stereoscopic image of the workpiece, it is also used for inspecting surface conditions (scratches). Adjust the angle of light so that the brightest image is obtained in the field of view.

Draw out the reflected illumination switching knob as shown below when using this illumination.

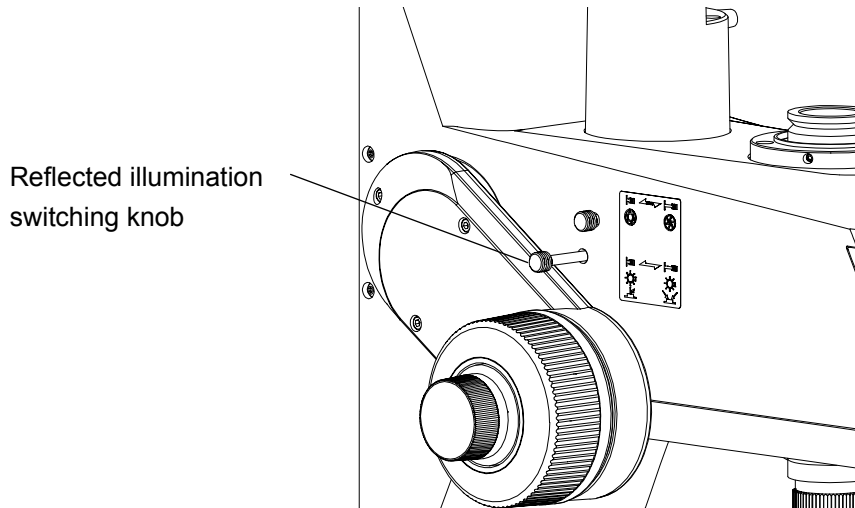

3.8 Selecting a Filter

Filters are attached to the transmitted illuminator and vertical reflected illuminator. Select those filters according to the usage.

Symbol	Filter type	Function and usage
L B 8 0	Color temperature conversion filter	Referred to as a light balance filter (LB filter). When the voltage of the halogen lamp is lowered to reduce the light intensity, the entire light of the lamp becomes red due to decrease in short-wavelength light. This filter converts the color temperature of the lamp to that of near natural light by reducing the transmission of long-wavelength light. This filter has an advantage in observation and capture of color images under the reflected illumination environment.
N D 2	Neutral filter (light)	Referred to as a neutral density filter. This filter is intended to reduce light in the visible region with no wavelength sensitivity. It is used for reducing the light intensity without lowering the color temperature of a light source. The ND2 filter will reduce the light intensity to 1/2 and the ND8 will reduce it to 1/8. This filter is effective in observation and capture of color images under the reflected illumination environment.
N D 8	Neutral filter (dark)	
G I F (※)	Green interference filter	One of interference filters with multi-layer films evaporated. This filter transmits only green spectral wavelength light with a central wavelength of 540nm and a half-width of 70nm. The filter provides a bright illumination with its greater half-width and transmittance, compared with a glass green filter. Particularly, this filter is used for increasing the resolution and contrast of images under the transmitted illumination environment.

(※) Standard accessories

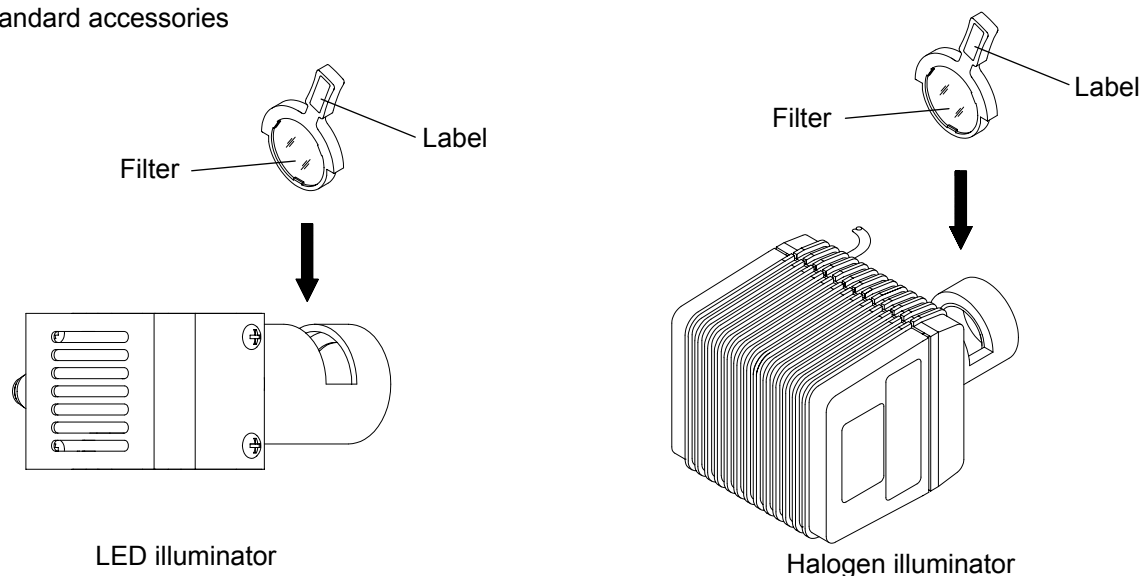

NOTE The illuminator housing is very hot. Be careful when installing the filter.

TIP Color temperature denotes the temperature of the complete black body that produces the same chromaticity as that of a light source under consideration. Turning a light source red refers to lowering the color temperature and turning it blue refers to raising the color temperature.

3.9 Adjusting the Pupil Distance

(The case in which the binocular unit is mounted)

Look through the eyepieces at the correct viewing angle and hold the binocular tubes with both hands. Adjust the angle between the tubes to your eyes by moving them in the directions shown below.

- Adjustable range of pupil distance : 51~76mm

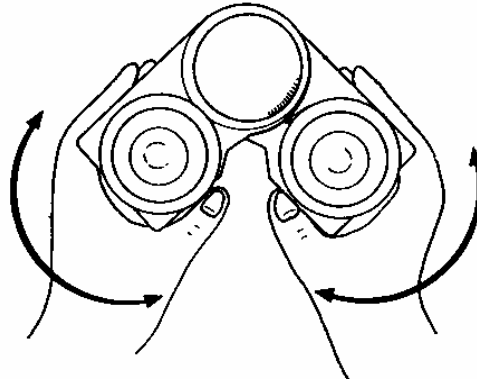

- NOTE**
1. The eyepieces employ a high-eye-point system with rubber eye cups attached. Turn the rims outward, as shown in the below figure, if you wear eyeglasses.

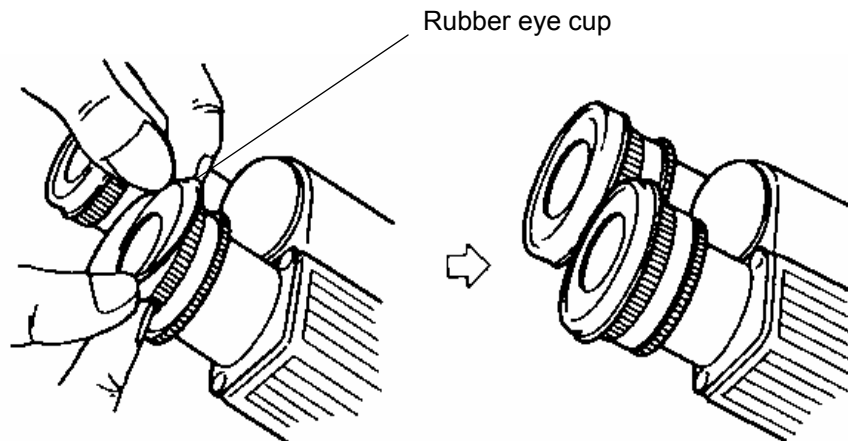

2. The binocular unit is supplied with polyethylene caps to shut off the light from the eyepieces during use of the TV port and for dust-preventive purpose during storage. (The cap is also supplied for the monocular unit.) Cover each polyethylene cap over the eye shade on individual eyepieces. If the eye shade is removed from the eyepiece, a play will be generated between the cap and eyepiece. Exercise a great care.

3.10 Adjusting the Diopter of Eyepiece

Adjust the diopter following below procedure.

- ① Hold the root of eyepiece by the hand to prevent the whole eyepiece from rotating during adjustment.
- ② Turn the diopter adjustment ring of eyepiece with the other hand to bring the cross-hair line into sharp focus.

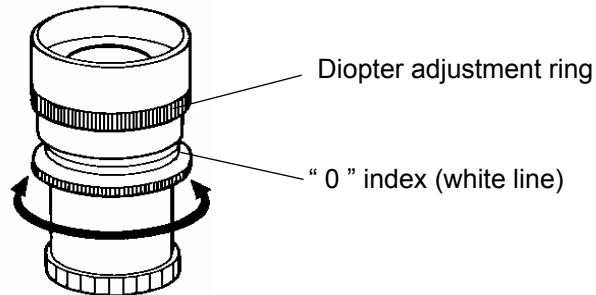

3.11 Replacing the Reticle

Insert the reticle unit into the slot on the side of optical tube unit to project the chart on the real image.

Insert the unit all the way into the slot with the fingertip hooking groove on the reticle unit orienting upward.

Loosen the reticle cover clamping screws slightly and slide the cover upward to remove the reticle.

Reticle cover clamping screw

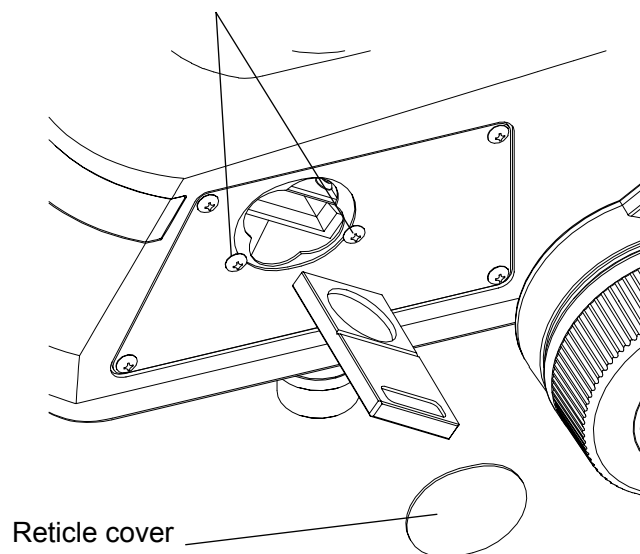

-
- NOTE**
1. The reticle unit should always be inserted in the slot. If the reticle unit is not inserted, an error may occur in the diopter.
 2. If the reticle unit is not completely inserted all the way into the slot, the shading may occur.
 3. The reticle cover should always be equipped. The dust may come inside of the optical tube if leave the reticle unit without the cover
-

3.12 Dimensional Measurement

The dimension of a workpiece is determined from the displacement of the XY stage .
The basic measuring procedure is as follows.

- ① Move the XY stage as one edge of workpiece meets the cross-hair.

Dimension to be measured

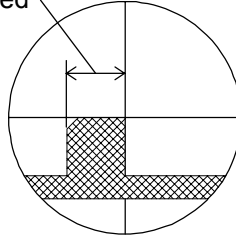

- ② Press the zero button of the X-axis to set the counter zero.



- ③ Move the XY stage as the other edge of workpiece meets the cross-hair.

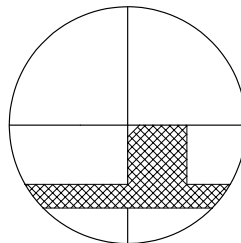

- ④ Take a reading from the counter.



MEMO

4

Maintenance

This chapter explains the daily maintenance that must be performed on the Measuring Microscope MF series, including cleaning and the replacement of consumables.

4.1 Cleaning External Parts

Gently wipe the contaminations from the main unit and stage glass with a soft cloth. If the contaminations are persistent, wipe them carefully with a cloth soaked in a diluted neutral detergent and tightly squeezed, then wipe dry with another cloth.

IMPORTANT Do not use benzene, thinner, or chemically treated cloth for cleaning since the surface may discolor and the paint may peel.

4.2 Maintaining the Lens

Always keep the lens clean and free of dust, oil, and fingerprints. If the lens got contaminated, wipe them according to the following procedure:

- Dust : Gently wipe it with a clean lens brush, soft brush, or gauze.
- Oil, fingerprints: Gently wipe with tissue paper for the lens or a gauze dampened with a small amount of absolute alcohol (ethanol, methanol) .

IMPORTANT To maintain optimal Measuring Microscope performance over an extended period, it should be periodically inspected by a Mitutoyo service engineer. For detailed information, contact your dealer or the nearest Mitutoyo service center.

4.3 Replacing Consumables

The halogen bulb and stage glass are consumables and need to be replaced. Follow the replacement procedure described in the instructions in safety.

4.3.1 Replacing halogen bulbs

- (1) Turn off the power to the system.
- (2) Allow a sufficient period of time for the bulb to cool.

IMPORTANT The bulbs and the peripherals stay hot for a period after use. Be sure to perform the above procedures and check that the bulbs have cooled, then proceed to the next step.

- (3) Turn off the power switch and pull out the power cord.

IMPORTANT Serious injury and risk of electrocution will result if cover is opened while power is on.

- (4) Loosen and remove two fixing screws for the head cover of illuminator (cross recessed pan head screws) by a supplied Philips screw driver.

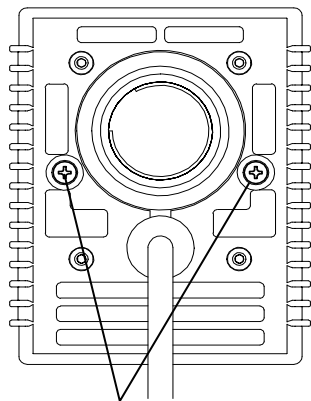

Fixing screws for head cover

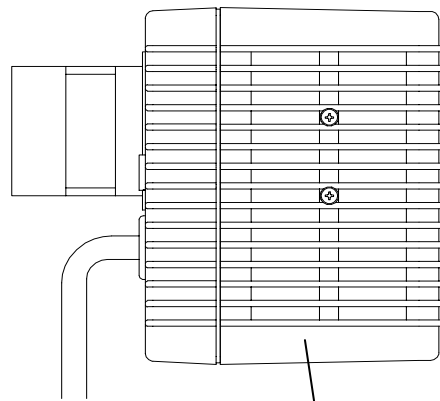

Head cover

4. Maintenance

- (5) Pull straight the old bulb, and then insert the new one into the socket. Do not touch the bulb directly with the bare hand, otherwise the glass surface is contaminated with the oil etc., resulting in the short life of the bulb.

Insert the bulb all the way until it reaches the end of the socket. If not inserted well enough, uniform illumination can not be obtained.

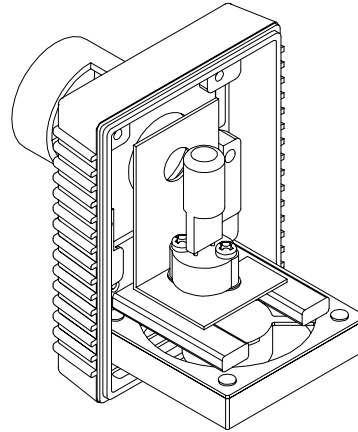

IMPORTANT Use only the specified halogen bulbs.

Unspecified halogen bulb may prevent the machine from performing efficiently.

TIP For information about the halogen bulbs type, refer to "6.3 List of Consumable".

4.3.2 LED illuminator replacement

The operating life of the LED illuminator is approximately 30,000 hours. If the illuminator is darker or not lighted, replace the LED illuminator assembly.

- (1) Set the light quantity of each bulb to 0%, and cool down the illuminator in the power-on state for approximately 10 minutes.

IMPORTANT Use of the illuminator may cause high temperatures. Be sure to perform the procedure below after turning off the power and confirming that the bulb is cooled.

- (2) Turn off the main power switch and pull out the power cord.

IMPORTANT Replacement operation in the power-on state may cause trouble resulting in harm to the operator.

- (3) Remove the connector of the LED illuminator from the rear of the main unit base.
- (4) Remove the illuminator unit from the microscope main unit.
- (5) Connect the connector of a new LED illuminator to the main unit base and the LED illuminator unit to the microscope main unit.

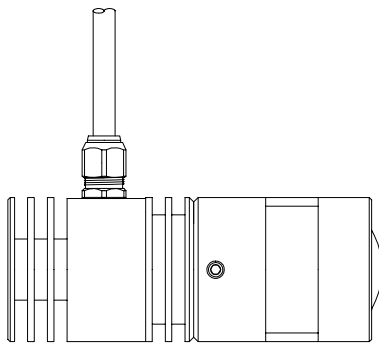

[LED reflected illuminator]

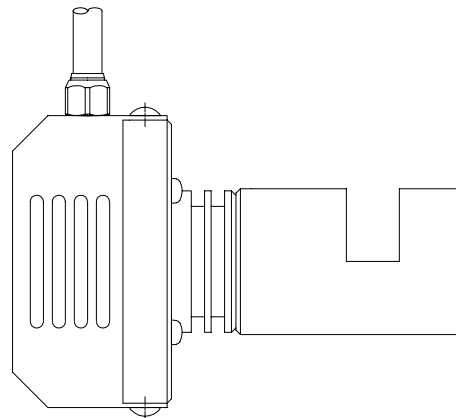

[LED transmitted illuminator]

TIP For information about the LED illuminator, refer to "6.3 Consumables".

4.3.3 Replacing the stage glass

- ① Loosen the fixing screws (4 pieces) to remove them along with each glass retainer.
- ② Remove the stage glass from the cross-travel stage.
- ③ Gently fit a new stage glass in the frame of the stage.
- ④ Carefully tighten the fixing screws so the stage glass will not move.

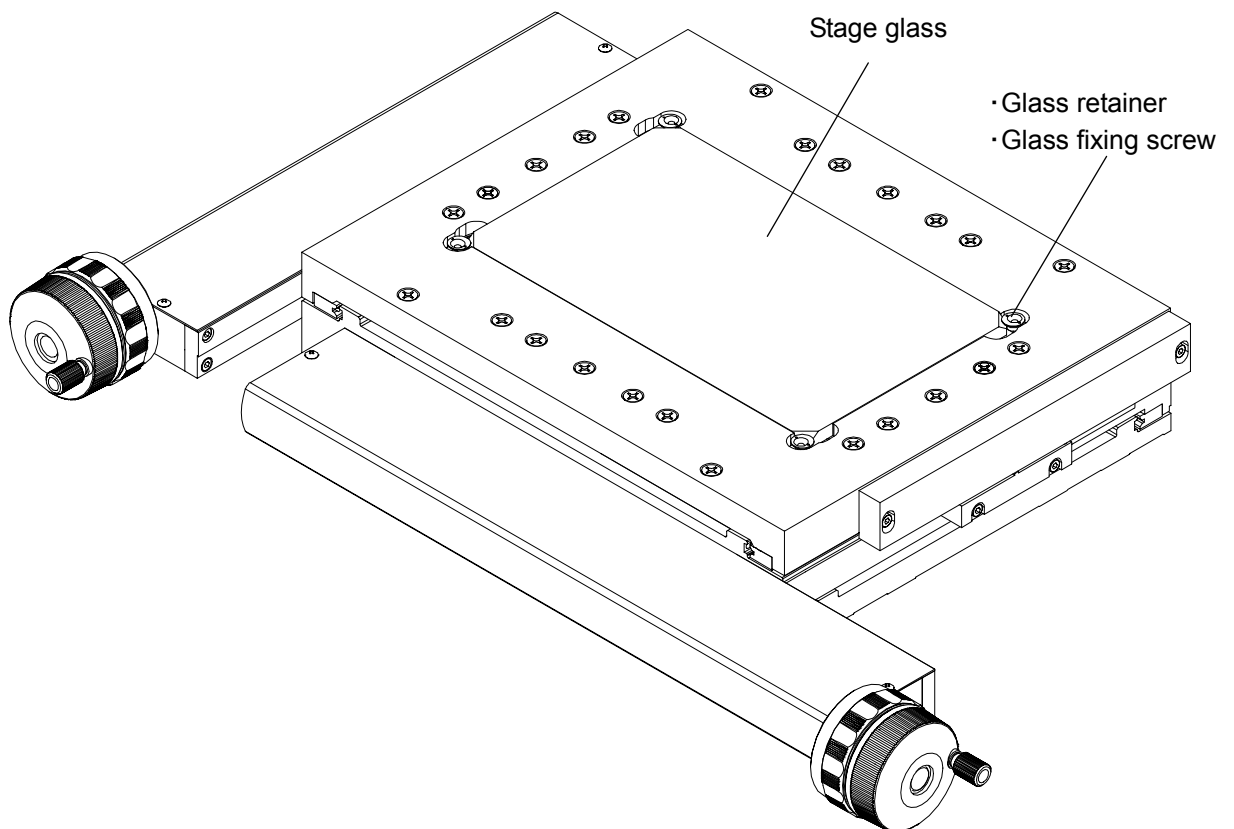

-
- NOTE**
1. If replacing the stage glass, be careful so as not to break it.
 2. Do not touch directly the stage glass with your bare hands due it is easy to get contaminated by fingerprints etc. Wear gloves.
-

4.3.4 Replacement of conston spring

- (1) Move the optical tube upward, place an appropriate spacer under the optical tube for fall prevention.
- (2) Remove the rear cover from the column.
- (3) Insert a driver into the work hole of the spring bracket, pull the conston spring upward, and disengage the wire from the pulley.
- (4) Move back the conston spring to the position where the spring is shortest.
- (5) Loosen the cross recessed truss-head screw and disengage the wire. (Pay attention not to lose the collar.)
- (6) Loosen the hexagon nut (M6) and remove the spring bracket and conston spring.
- (7) Loosen the hexagon socket head cap screws (2 pieces, M3), remove the shaft from the column, and replace the conston spring.
- (8) Put back the shaft to the column.
- (9) Put the spring bracket and conston spring together with a gap maintained using the hexagon socket head cap screws (2 pieces) and hexagon nuts (2 pieces). (If there is no gap, the wire cannot be evenly pulled.)
- (10) Engage the wire with the spring bracket using the cross recessed truss-head screw and collar.
- (11) Insert a driver into the work hole of the spring bracket, pull the conston spring upward, and engage the wire with the pulley.
- (12) Put back the rear cover to the column.

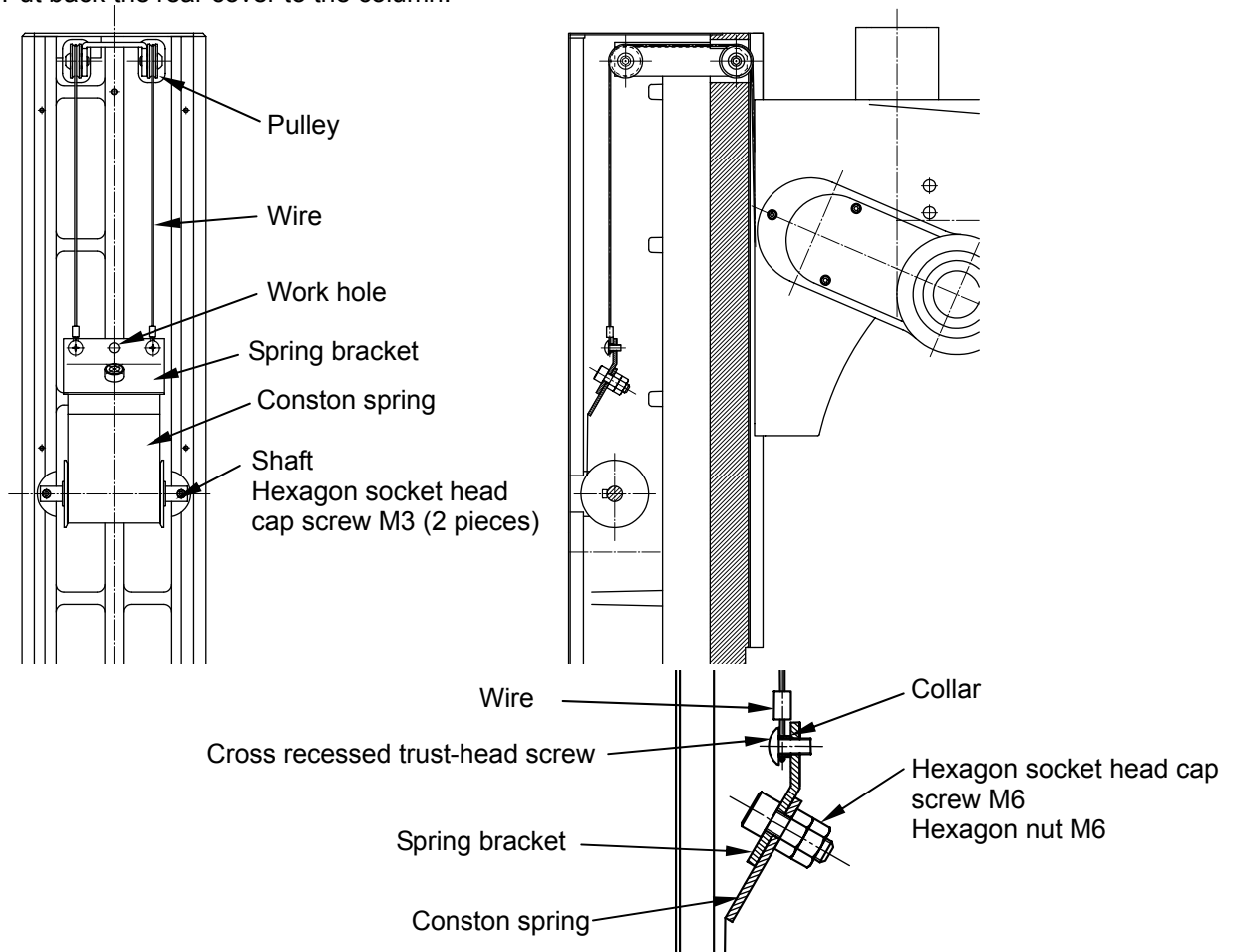

IMPORTANT Use caution not to hurt your fingers with the edge of the conston spring.

NOTE Prepare a hexagon wrench (nominal size 5) and a spanner (nominal size 10) for putting hexagon socket head cap screws and hexagon nuts in addition to the standard tools (accessories).

5

Troubleshooting

This chapter describes the check points and remedies if a symptom of trouble in the Measuring Microscope system is encountered.

5.1 Main Unit

	Symptom	Check point	Remedy
1)	Nothing is displayed on the counter when the power switch is on.	1) Is the power cord securely connected? 2) Is the cable connected correctly between the microscope main unit and controller? 3) Is the main power switch turned on? 4) Is the auxiliary power switch turned on?	1) Connect the power cord securely. 2) Disconnect the cable once and re-connect it securely. 3) Turn on the main power switch. 4) Turn on the auxiliary power switch.
2)	The image is unclear.	1) Check if the lens and workpiece are stained. 2) Check if the light intensity of the illumination is improper. 3) Check if the lens is loosened. 4) Check the environments for vibration and electric noise.	1) Clean the lens and workpiece. 2) Adjust the light intensity. 3) Tighten the lens. 4) Optimize the environmental conditions.
3)	Abnormal sound and vibration are generated.	1) Check if the legs on the main unit/installation stand are loose. 2) Check if the main unit/installation stand is not level.	1) Tighten the legs on the main unit/installation stand correctly. 2) Perform leveling of the main unit/installation stand.
4)	The measurement data will not be steady.	1) Check if the stage glass is fixed. 2) Check if the lens is loosened. 3) Check if the workpiece is fixed properly. 4) Check if the lens and glass are contaminated. 5) Check if the environmental conditions such as the temperature and vibration are within the tolerance range.	1) Fix the stage glass. 2) Tighten the lens. 3) Fix the workpiece properly. 4) Clean the lens and glass. 5) Optimize the environmental conditions.
5)	The optical tube unit is stiff in the vertical motion.	1) Remove the rear cover on the column and check the Conston spring (constant force spring) for abnormality such as broken wire.	1) If the Conston spring (constant force spring) is proved to reach the end of its life, contact your dealer or the nearest Mitutoyo sales office.
6)	The buzzer keeps sounding.	1) The buzzer keeps sounding from the controller.	1) Refer to "5.4 Error Messages and Remedies" – "5.4.2 Illuminator and concerned matters".

5.2 Counter Unit





	Symptom	Check point	Remedy
1)	Nothing is displayed on the counter when the power switch is on.	1) Is the power cord securely connected? 2) Is the cable connected correctly between the microscope main unit and controller? 3) Is the main power switch turned on? 4) Is the auxiliary power switch turned on?	1) Connect the power cord securely. 2) Disconnect the cable once and re-connect it securely. 3) Turn on the main power switch. 4) Turn on the auxiliary power switch.
2)	Counter display is locked (no counting.)	1) Turn the power switch off, then turn it on after at least 5 seconds.	1) Try a few times. If the counter still does not count, contact your dealer or the nearest Mitutoyo sales office.
3)	Miscounting	1) Is the main unit GND terminal grounded securely with the power cord? 2) Is there any noise source nearby? 3) See "Counter display is locked" category in Malfunction column.	1) Securely ground the wire from the main unit GND terminal. 2) The counter should be separated by at least 0.5m from high-voltage or large-current sources and high-capacity relays. 3) If the counter or any Linear Scale is found to be damaged, contact your dealer or the nearest Mitutoyo sales office.
4)	Count value fluctuates	1) Are vibrations affecting the Linear Scales? 2) Is the mounting stand strong enough?	1) Take countermeasures to minimize the effects of the vibration. 2) Confirm the strength of the mounting stand on which the microscope is installed.
5)	Errors of "E20" and "F30" are displayed.	1) Refer to "5.4 Error Messages and Remedies".	
6)	Errors of "E51" and "E52" and "E53" are displayed.	1) Refer to "5.4 Error Messages and Remedies". 2) Have the power switches been turned on or off according to the note of "3.2 Turning the Power Supply On"?	1) Refer to "5.4 Error Messages and Remedies". 2) Turn the power switches on or off in the following order. · For ON Peripheral equipment → Microscope main unit · For OFF Microscope main unit → Peripheral equipment

5.3 Illuminator and Concerned Matters

	Symptom	Check point	Remedy
1)	Dark or unlighted Transmitted illuminator/vertical reflected illuminator	<p>[LED illuminator] 1) The illuminator is dark or unlighted.</p> <p>[Halogen illuminator] 1) Is the halogen bulb OK? 2) Does the halogen bulb meet the specification?</p> <p>[Common to LED / Halogen illuminator] 1) Is the power cord disconnected? 2) Is the main unit connected to the illuminator properly? 3) Is the main power switch turned on? 4) Is the auxiliary power switch turned on? 5) Is the cable for each illuminator properly connected? 6) Is the cooling fan of each illuminator working? 7) Is the installation environment of the microscope kept at a proper temperature? 8) Is the illuminator energy saving activated?</p>	<p>1) If the symptom is not solved after disconnecting the illuminator once and reconnecting it, replace the LED illuminator. (Contact your dealer or the nearest Mitutoyo sales office.)</p> <p>1) Replace the halogen bulb. 2) Replace the bulb with new bulb with the same rating.</p> <p>1) Disconnect the illuminator once and re-connect it securely. 2) Disconnect the illuminator once and re-connect it securely. 3) Turn on the main power switch. 4) Turn on the auxiliary power switch. 5) Disconnect the cable once and re-connect it securely. 6) Restart the power of the microscope. If the same symptom occurs, contact Mitutoyo Service Center. 7) Turn off the power of the microscope, then turn it on again at least 10 minutes later. 8) Set the " F10 " counter parameter to " 0:None ". (Refer to " About parameters " explained in selection 1.2.4 " DRO Counter Unit ", Section 1.2 " Name and Function of Each Unit".)</p>
2)	Disabled optional illuminator at use of vision unit	1) The optional illuminator does not work with QSPAK VUE appropriately.	1) Check whether the control cable of the external illuminator is connected to the counter unit. (Refer to "1.2 Name and Function of Each Part" - "1.2.4 Counter unit".)
3)	Ceaseless buzzer	1) The buzzer keeps sounding from the controller.	1) Refer to "5.4 Error Messages and Remedies" – "5.4.2 Illuminator and concerned matters".

5.4 Error Messages and Remedies

5.4.1 Counter and concerned matters

LED display	Meaning and remedy
	Overspeed arising ; Traverse speed of the axis which displayed the error is too fast. ... Press the zero-set button of the axis which displayed the error or restart the microscope main unit.
	Overcount arising ; The scale of the axis which displayed the error exceeds the possible counting range. ... Return the scale of the axis which displayed the error to the possible counting range or restart the microscope main unit.
	RS232C parity error ... Press the X-axis zero-set button or send C0 (zero) command by RS-232C from peripheral devices such as PC. Restart both of the peripheral devices and the microscope main unit when the communication is not resumed.
	RS232C over-run error ... Press the X-axis zero-set button or send C0 (zero) command by RS-232C from peripheral devices such as PC. Restart both of the peripheral devices and the microscope main unit when the communication is not resumed.
	RS232C framing error ... Press the X-axis zero-set button or send C0 (zero) command by RS-232C from peripheral devices such as PC. Restart both of the peripheral devices and the microscope main unit when the communication is not resumed.

TIP When an error code has been cleared (power is turned on), the counter displays all zeros. Perform measurement from the start.

5.4.2 Illuminator and concerned matters

An error detected in the illuminator section is observed with the LED blinking (green) of “the auxiliary power switch” on the control panel with buzzers generated from the controller.

When an error is detected, the LED of the auxiliary power switch blinks after a buzzer. Buzzers and blinking repeat at intervals of 20 seconds.

Buzzer count	Auxiliary power switch	LED blink count
2 times (beep)	2 – off – 2	<ul style="list-style-type: none"> • The overcurrent protection circuit of the fan integrated into the transmitted illuminator or reflected illuminator functions. • • • Turn off the main power and start the system after a while. If the same error is detected again, contact your dealer or the nearest Mitutoyo sales office.
	2 – off – 3	<ul style="list-style-type: none"> • The fan integrated into the reflected illuminator is restrained or the connector of the fan is not connected. • • • Turn off the main power and check whether a foreign object interferes with the fan, or disconnect the connector of the illuminator and connect it again. If the same error is detected again, contact your dealer or the nearest Mitutoyo sales office.
	2 – off – 4	<ul style="list-style-type: none"> • The fan integrated into the transmitted illuminator is restrained or the connector of the fan is not connected. • • • Turn off the main power and check whether a foreign object interferes with the fan, or disconnect the connector of the illuminator and connect it again. If the same error is detected again, contact your dealer or the nearest Mitutoyo sales office.
3 times (beep)	3 – off – 2	<ul style="list-style-type: none"> • The LED reflected illuminator is not connected correctly. • • • Turn off the main power, disconnect the connector of the LED reflected illuminator, and connect it again.
	3 – off – 3	<ul style="list-style-type: none"> • The LED transmitted illuminator is not connected correctly. • • • Turn off the main power, disconnect the connector of the LED transmitted illuminator, and connect it again.
	3 – off – 7	<ul style="list-style-type: none"> • The cable inside the control panel breaks. • • • If the same error is detected again after turning off the main power, contact your dealer or the nearest Mitutoyo sales office.

IMPORTANT

To cancel an error, be sure to turn off the main power switch first and treat the matter.

MEMO

6

Specifications

This chapter describes the specifications, standard accessories, and optional accessories of the Measuring Microscope.

6.1 Common Specifications

Model No.	2 Axes type	MF-A505C	MF-A1010C	MF-A2010C	MF-A2017C	MF-A3017C	MF-A4020C
	3 Axes type	MF-B505C	MF-B1010C	MF-B2010C	MF-B2017C	MF-B3017C	MF-B4020C
Optical tube		<ul style="list-style-type: none"> Reticle projection type: Erect image · with TV port Optical path fixed type: Observation/TV=50/50 Vertical tilt angle: 25 degrees · Reticle: 90° broken-cross line (line width 5µm) 					
Eyepiece unit (option)		<ul style="list-style-type: none"> Monocular unit (with a 10X eyepiece) · Binocular unit (with two 10X eyepieces) 					
Objective (standard)		<ul style="list-style-type: none"> 3X (standard accessory) 					
Objective (option)		<ul style="list-style-type: none"> 1X,5X,10X,20X,50X,100X 					
Illuminator unit (Option: requisite selection)	LED illuminator	<ul style="list-style-type: none"> Transmission: Telecentric system · Built-in aperture diaphragm · White LED light source · Non-step light intensity control · with Air-cooling fan Reflection: Koehler illumination · with Adjustable aperture diaphragm · White LED light source · Non-step light intensity control Control unit: Main power ON/OFF switch (main switch) · AC power inlet connector 100-240V 					
	Halogen	<ul style="list-style-type: none"> Transmission: Telecentric system · Built-in aperture diaphragm · Halogen bulb 12V, 50W · Non-step light intensity control · with Air-cooling fan Reflection: Koehler illumination · with Adjustable aperture diaphragm · Halogen bulb 12V, 50W · Non-step light intensity control · with Air-cooling fan Control unit: Main power ON/OFF switch (main switch) · AC power inlet connector 100-240V 					
Illumination filter		<ul style="list-style-type: none"> Detachable/attachable green filter : 1 piece supplied (detachable/attachable for both reflected and transmitted illuminators) 					
Control panel		<ul style="list-style-type: none"> Power switch (accessible sub switch for operation) Adjustable aperture diaphragm (Transmitted) Transmitted illuminator: OFF~Non-step Reflected illuminator: OFF~Non-step 					
Z-axis	Traverse range	150 mm (5.9")			220 mm (8.7")		
	Feeding mechanism	<ul style="list-style-type: none"> 1-axis coarse / fine feed Both left / right wheel (coarse: 30 mm(1.18") / full-turn, fine: 0.2 mm(0.008") / full-turn) 					
Cross-travel stage	Traverse range	50×50mm (2.0" X 2.0")	100×100mm (3.9" X 3.9")	200×100mm (7.9" X 3.9")	200×170mm (7.9" X 6.7")	300×170mm (11.8" X 6.7")	400×200mm (15.7" X 7.9")
	Stage surface dimensions	280×280mm (11.0" X 11.0")	280×280mm (11.0" X 11.0")	350×280mm (13.8" X 11.0")	410×342mm (16.1" X 13.5")	510×342mm (20.1" X 13.5")	610×342mm (24.0" X 13.5")
	Stage glass dimensions	180×180mm (7.1" X 7.1")	180×180mm (7.1" X 7.1")	250×150mm (9.8" X 5.9")	270×240mm (10.6" X 9.4")	370×240mm (14.6" X 9.4")	440×240mm (17.3" X 9.4")
	Quick release mechanism	Built-in at both X-axis and Y-axis					
	Indication Accuracy	(2.2+0.02L) µm L : Measuring length (mm): Compliant with the measuring method of JIS B 7153					
	Table rotating function	None			with Swivel mechanism ±5°		±3°
	Maximum load	10kg (22.1 lb)	10kg (22.1 lb)	10kg (22.1 lb)	20kg (44.1 lb)	20kg (44.1 lb)	15kg (33.1 lb)
Counter	Number of axes	3 axes or 2 axes					
	Resolution	0.001 / 0.0005 / 0.0001mm (0.0001 / 0.00005 / 0.00001") switchable					
	Function	Zero setting / Direction mode selection / RS-232C output					
Dimensions		562x730x667 22.1"x28.7"x26.2"	562x730x667 22.1"x28.7"x26.2"	624x745x667 24.6"x29.3"x26.2"	632x892x782 24.8"x35.1"x30.8"	682x892x782 26.9"x35.1"x30.8"	757x907x782 29.8"x35.7"x30.8"

Weight of main unit	65.5kg (144 lb)	65.5kg (144 lb)	69.5kg (153 lb)	130kg (286 lb)	138kg (304 lb)	144kg (317 lb)
Weight of control unit	2.0 kg (4.4lb)					
Max. power consumption	LED	45 W				
	Halogen	160 W				

6.2 Standard Accessories

6.2.1 Standard accessories for measuring microscope main unit

Order No.	Item name	Quantity
375-037-1	Objective 3X	1
12AAA645	GIF filter	1
99MBA091J	User's Manual (Japanese)	1 (select any one kind)
99MBA091A	User's Manual (English)	
99MBA091C	User's Manual (simplified Chinese)	
472730	Warranty	1
382951	Dust cover	1
12BAD595	Magnet plate	3 (only for 3 axes type)
380597	Setting screw	2
12BAH619	Swivel clamp screw	1
12BAH612	Hexagon socket button head screw M6x20	1
512926	Cap (2010 less)	4 (select any one kind)
12BAC490	Cap (2017 over)	
12BAD487	Hanger bolt (2010 less)	4 (select any one kind)
12BAG808	Hanger bolt (L) (2017 over)	
12BAG897	Setting piece (2017 over)	5
538615	Allen wrench (nominal 2.5)	1
538616	Allen wrench (nominal 3)	1
353491	Philips screwdriver	1

6.2.2 Standard accessories for illuminator

Order No.	Item name	Quantity
02ZAA000	Power cord (home)	1 (select any one kind)
02ZAA010	Power cord (UL, CSA)	
02ZAA020	Power cord (CEE)	
02ZAA030	Power cord (BS)	
02ZAA040	Power cord for CCC	
02ZAA050	Power cord SP-023+IS14 (for KOREA)	
513667	Halogen bulb (12V, 50W) ※1	3 (only for halogen type)
12AAJ770	Extension cable for halogen power supply (transmitted)	1 (only for halogen type)
12AAJ771	Extension cable for halogen power supply (reflected)	1 (only for halogen type)
1126-0105	Ferritic core	2 (only for halogen type) (mounted on 12AAJ770 / 12AAJ771)

※1: The lamp used for this instrument is designed for special purpose, and not suitable for household room illumination.

6.3 List of Consumable

Part name	Product No.	Remark
Halogen bulb (12V, 50W) ※1 (High-bright type)	513667	Common use for transmitted and vertical reflected illumination (Made by NARVA Co. 57901)
Halogen bulb (12V, 50W) ※1 (Long life type)	12BAB345	Common use for transmitted and vertical reflected illumination (Made by OSRAM Co. 64602)
Stage glass	12BAD381	For MF- * 505C
Stage glass	12BAD381	For MF- * 1010C
Stage glass	12BAD760	For MF- * 2010C
Stage glass	12BAD363	For MF- * 2017C
Stage glass	12BAD330	For MF- * 3017C
Stage glass	12BAH968	For MF- * 4020C
Conston spring	12BAD284	
LED transmitted illuminator	12AAJ720	For transmitted illumination (cooling fan equipped)
LED reflected illuminator	12AAJ721	For vertical reflected illumination

※1: The lamp used for this instrument is designed for special purpose, and not suitable for household room illumination.

6.4 Optional accessories

○: applicable, —: not applicable

No.	Part name	MF-*505C	MF-*1010C	MF-*2010C	MF-*2017C	MF-*3017C	MF-*4020C
176-392	Monocular tube	○	○	○	○	○	○
176-393	Binocular tube	○	○	○	○	○	○
378-857	Eyepiece 15×	○	○	○	○	○	○
378-858	Eyepiece 20×	○	○	○	○	○	○
375-043	Protractor eyepiece 10×	○	○	○	○	○	○
176-313 ※1	Digital protractor eyepiece 10×	○	○	○	○	○	○
—	Objective	○	○	○	○	○	○
176-314-1	# Slide type nosepiece	○	○	○	○	○	○
176-314-2	# Slide type nosepiece	○	○	○	○	○	○
176-351-6	Oblique surface illuminator	○	○	○	○	○	○
176-367-2 ※1	▽ LED ring optics illuminator	○	○	○	○	○	○
375-057 ※1	Focus pilot FP-05	○	○	○	○	○	○
12AAA165	Lens cleaning set	○	○	○	○	○	○
375-056	Objective micrometer	○	○	○	○	○	○
176-107	Holder with clamp	○	○	○	○	○	○
172-378	V-block & clamp	○	○	○	○	○	○
176-305	Rotary stage with fine feed knob (A)	○	○	○	—	—	—
176-306	Rotary stage with fine feed knob (B)	—	—	—	○	○	○
176-308	Vibration damping stand	○	○	○	○	○	○
176-309	Mounting stand	○	○	○	○	○	○
—	Various reticles	○	○	○	○	○	○
375-054	★ 0.5× camera adapter unit (C-mount adapter equipped)	○	○	○	○	○	○
970441	★ C-mount adapter	○	○	○	○	○	○
176-343 ※1	● Twin fiber-optic illuminator	○	○	○	○	○	○
176-366 ※1	● Ring fiber-optic illuminator	○	○	○	○	○	○
12AAG806	○ GIF filter (for 100W illumination)	○	○	○	○	○	○
12AAG807	○ LB80 filter (for 100W illumination)	○	○	○	○	○	○
172-197	◇ Swivel center support	○	○	○	○	○	○
176-304	◆ Stage adapter	—	—	—	○	○	○
176-310	◆ Stage adapter (B)	—	—	○	—	—	—
264-145 ※1	△ QM-Data200	○	○	○	○	○	○
12AAA807	▲ RS-232C cable	○	○	○	○	○	○
359-737	Vision unit 9B (export)	○	○	○	○	○	○
12AAD128	■ External light source control cable (for 100W light source)	○	○	○	○	○	○
12AAG888	▼ External light source control cable (for 150W light source)	○	○	○	○	○	○
176-345	LED illuminator (MF)	○	○	○	○	○	○
176-347	Halogen illuminator (MF)	○	○	○	○	○	○
12AAA643	ND2 filter ※2 (light quantity: 50%)	○	○	○	○	○	○
12AAA644	ND8 filter ※2 (light quantity: 13%)	○	○	○	○	○	○
12AAA646	LB80 filter ※2	○	○	○	○	○	○

When ☆ is used, use together ★ C-mount or 0.5x adapter unit.

○ is dedicated option for ● illuminator.

To control ● illuminator from the vision unit, ■ External light source control cable is required.

To control ▽ illuminator from the vision unit, ▼ External light source control cable is required.

When ◇ is used, use together ◆ Stage adapter (only 200x100, 200x170, 300x170, 400x170).

When △ is used, also use ▲RS-232C cable.

Hold with clamp, V-block & clamp, Swivel center support can be attached on Rotary stage with fine feed knob (A).

mark is factory set option.

※1:Order No. is different by using line voltage.

※2 is for halogen illuminator.

6.5 Objectives, Eyepieces Specification Table

Bright-field objective				Eyepiece WF, wide field of view								
				WF10 x/24			WF15 x/16			WF20 x/12		
M	N.A.	W.D.	R (μm)	T.M.	ϕ	F.D. (μm)	T.M.	ϕ	F.D. (μm)	T.M.	ϕ	F.D. (μm)
1 x	0.03	59	9.2	10 x	24	782	15 x	16	623	20 x	12	544
3 x	0.09	77	3.1	30 x	8	86.9	45 x	5.3	69.2	60 x	4	60.4
5 x	0.13	61	2.1	50 x	4.8	38.3	75 x	3.2	30.9	100 x	2.4	27.3
10 x	0.21	51	1.3	100 x	2.4	13	150 x	1.6	10.8	200 x	1.2	9.6
20 x	0.42	20	0.7	200 x	1.2	3.3	300 x	0.8	2.7	400 x	0.6	2.4
50 x	0.55	13	0.5	500 x	0.48	1.4	750 x	0.32	1.3	1000 x	0.24	1.2
100 x	0.70	6	0.4	1000 x	0.24	0.8	1500 x	0.16	0.7	2000 x	0.12	0.7

Note) M : Magnification
 N.A. : Numerical aperture
 W.D. : Working distance (mm)
 R : Resolution(μm)
 T.M. : Total magnification
 ϕ : Field of view (ϕmm)
 F.D. : Focal depth (μm)

Assuming that the resolution of human eye is $2'$

$$R = \frac{\lambda}{2 \times \text{N.A.}} \quad \lambda = 0.55 \mu\text{m} \text{ (Standard wavelength)}$$

$$\text{F.D.} = \frac{\lambda}{2 (\text{N.A.})^2} + \frac{1000}{7 \times \text{N.A.} \times \text{T.M.}}$$

6.6 Layout of the Optical System

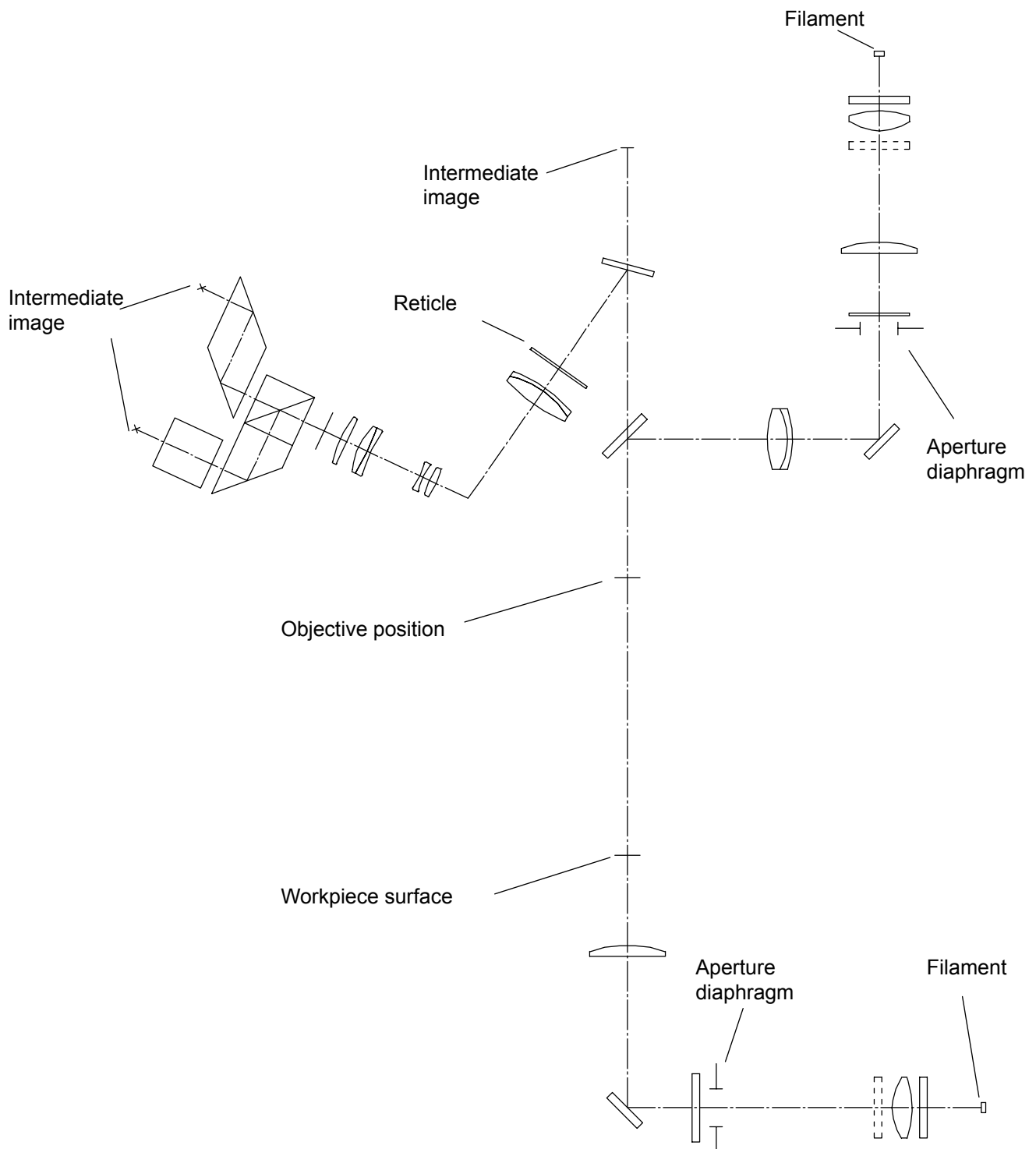

6.7 Serial Data Output Specifications of the Counter

The measured date of the counter unit is output via the serial output connector to a peripheral, such as two-dimensional data processing unit Micropak 9/7 or two-dimensional data processing program QSPAK.

Communication Specifications

- Transmission method : Half duplex
- Transmission control : Asynchronous (Start-stop transmission)
- Baud rate : 1200bps/2400bps/4800bps/9600bps^(※1)/19200bps
- Data bit : 7 bits^(※1)/8 bits ASCII
- Parity bit : Even^(※1)/Odd/None
- Stop bit : 1 bit^(※1)/2 bits
- Flow control : Enabled/Disabled^(※1)

(※1) Default setting at the shipment

6.7.1 Connector specifications

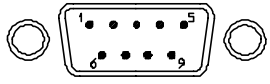
Connector shape	Pin number	Signal	I/O direction ※2	Description
 D-sub, 9 pins, male, inch thread	1			
	2	RD	IN	Accept the command
	3	TD	OUT	Measured data
	4	DTR	OUT	Counter is ready
	5	SG	—	Signal ground
	6	DSR	IN	Peripheral is ready
	7	—	—	
	8	—	—	
	9			
	FG	—	—	Frame ground

(※2) In/Out direction OUT : counter → Peripheral

The input/output circuits used are equivalent to MAX232 (MAXIM Corporation).

6.7.2 Control signal

A data request from a peripheral is accepted only if the DTR signal is “H” (space).
“H” has a +9V level.

The counter unit can transfer only if the DSR signal is “H” (space).

Example of cable that can be used

The following illustrates two types of reference cables which are used to connect the counter to a DOS/V PC. One of the cables does not use control lines and other uses control lines.

Cable 1 (Control lines are not used)

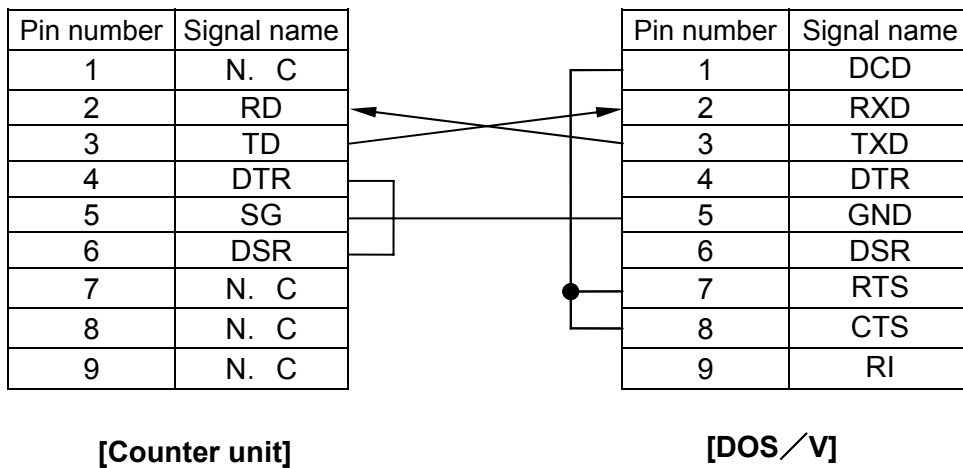

Cable 2 (Control lines are used)

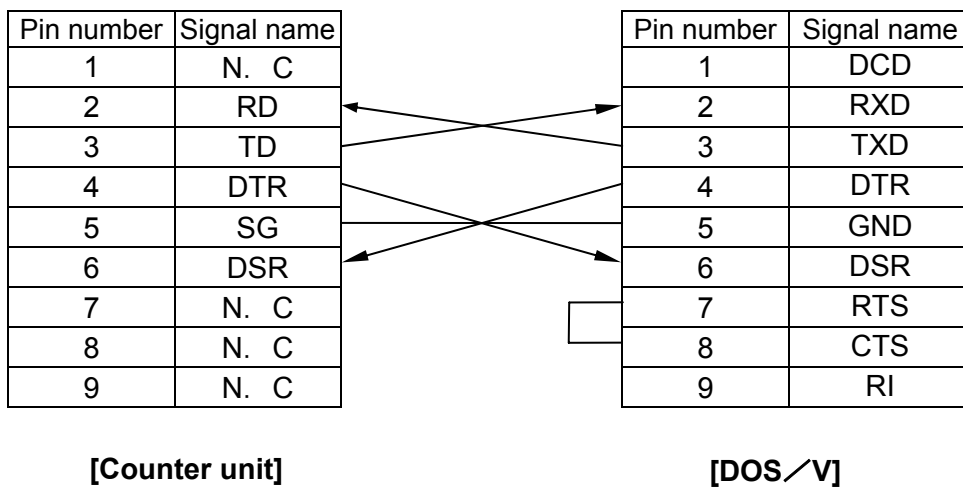

6.7.3 Data output operation

A displayed value on the counter unit can be output by inputting an external load signal or commands from a peripheral, such as a personal computer.

(1) Data output

A) For the external load signal

Only the data on the axis on which the external load box switch is pressed is output to a peripheral.

B) For the command from peripheral

Data is output to a peripheral by inputting the following character strings (commands) from the peripheral, such as a personal computer.

List of command from peripheral

Input command			Output data
X	CR	LF	X-axis data
Y	CR	LF	Y-axis data
Z	CR	LF	Z-axis data
A	CR	LF	Three-axes data

(2) Output format

The Output data is output in the specified format.

Below are given output examples of various kinds of data for a signal-axis counter and multi-axes counter.

1) Single-axis counter output

A) If "123.4567" is displayed on the X-axis counter

X		+	1	2	3	.	4	5	6	7	CR	LF
---	--	---	---	---	---	---	---	---	---	---	----	----

B) If "0.0000" is displayed on the Y-axis counter

Y		+	0	0	0	.	0	0	0	0	CR	LF
---	--	---	---	---	---	---	---	---	---	---	----	----

2) Multi-axes counter output

A coordinate data of each axis is the same as the output format of a single-axis counter.

For two-axes)

X-axis data	,	Y-axis data	CR	LF
-------------	---	-------------	----	----

For three-axes)

X-axis data	,	Y-axis data	,	Z-axis data	CR	LF
-------------	---	-------------	---	-------------	----	----

3) Summary of external device data and output data

By pressing the switch on the external load box or upon reception of commands from the peripheral, the counter unit outputs the following data.

External load box switch	Commands from the peripheral			Output data									
X	X	CR	LF	→	X-axis data	CR	LF						
Y	Y	CR	LF	→	Y-axis data	CR	LF						
Z	Z	CR	LF	→	Z-axis data	CR	LF						
A	A	CR	LF	→	X-axis data	,	Y-axis data	,	Z-axis data	CR	LF		

4) Error

Next error code is output, when the error arises in the counter.

RS232C error code	Display	Error cause	Remedy (method of return)
N G 0 5 CR LF	E51	Parity error arising	1) Press the X-axis zero-set button. 2) Transmit C0 (zero) command from the peripheral equipment at RS232C.
N G 0 7 CR LF	E52	Over-run error arising	
N G 0 8 CR LF	E53	Framing error arising	
N G 0 9 CR LF	—	Receiving the undefined command	Correspond by the normal command.
X E 2 0 CR LF	E20	X-axis overspeed arising	1) Press the X-axis zero-set button. 2) Transmit C0 (zero) command.
Y E 2 0 CR LF	E20	Y-axis overspeed arising	
Z E 2 0 CR LF	E20	Z-axis overspeed arising	
X F 3 0 CR LF	F30	X-axis overcount arising	Return to the range in which the counting is possible.
Y F 3 0 CR LF	F30	Y-axis overcount arising	
Z F 3 0 CR LF	F30	Z-axis overcount arising	

TIP The error with high priority is displayed, when the multiple error phenomena arises simultaneously. If the error is canceled by C0 (zero) command, etc., the error with next high priority is displayed.

6.7.4 Connecting Micropak

It is necessary to perform the Micropak 9 / 7 / 5 setting when connecting the Micropak to the counter unit.

For information about setting up Micropak 9 / 7 / 5, refer to the Micropak user's manual.

(1) Connection

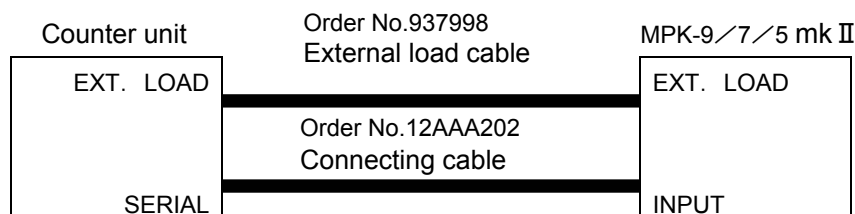

(Set No.12AAA500 for two pieces of above mentioned cable)

(2) Micropak 9 setup

- ① Set Equipment-->Counter-->Baud Rate-->9600 bps
- ② Set Equipment-->Counter-->X-axis Counter-->RS-232C Connection
Y-axis Counter-->RS-232C Connection
Z-axis Counter-->RS-232C Connection
- ③ Set Equipment-->Counter-->Counter connected-->MF
- ④ Set Conditions-->Measuring Rang-->X Y Z

(3) Micropak 7 setup

- ① Set Equipment-->Counter-->Baud Rate-->9600 bps
- ② Set Equipment-->Counter-->X-axis Counter-->RS-232C Connection
Y-axis Counter-->RS-232C Connection
Z-axis Counter-->RS-232C Connection
- ③ Set Equipment-->Counter-->Counter connected-->Others-->Counter(100ms)
- ④ Set Conditions-->Measuring Rang-->X Y Z

(4) Micropak 5 setup

Set the Dip switch DPS1 and DPS2 according to the following.

- ① DPS1 No.1 : ON, No.2 : OFF, No.3 : OFF, No.4 : OFF 4800 bps
- ② DPS2 No.5 : ON, No.6 : OFF

Modify also the parameter setup of the counter simultaneously. (Set "4800bPS" at the parameter number F07-1 according to "1.2.4.1 About parameters".)

NOTE To connect the counter to Micropak 5, unless the default setting are modified, the counter cannot be connected to Micropak 5. (Because MPK-5 does not accept the Z-axis data.) Modify also the parameter setup of the counter so that Z-axis output may not be performed. (Set "2 AS" at the parameter number F08 according to "1.2.4.1 About parameters".)

6.7.5 Connecting DPU-414 (Printer)

(1) Software DIP SW 1-3 setting

Notice : Do not turn off power while during start up setting. (The procedure cannot be skipped.)

Remark : Set the [FEED] key off, and the [ON LINE] key on.

Key operation	Contents of printout	Remarks
Turn the power switch "ON" pressing the [ON LINE] key	Automatically print the present DPU-414 setting. At the last line, the prompts are printed as below: Continue ? :Push 'On-line SW' Write ? :Push 'Paper feed SW'	Start startup setting
[ON LINE]	Dip SW-1	Setting of SW1
[FEED] [ON LINE] [ON LINE] [FEED] [ON LINE] [FEED] [ON LINE] [ON LINE]	(off)(on)(on)(off) (on)(off)(on)(on) Continue ? :Push 'On-line SW' Write ? :Push 'Paper feed SW'	Input method: Serial CR=CR Printing density = 100%
[ON LINE]	Dip SW-2	Setting of SW2
[ON LINE] [ON LINE] [ON LINE] [ON LINE] [ON LINE] [ON LINE] [ON LINE] [ON LINE]	(on)(on)(on)(on) (on)(on)(on)(on) Continue ? :Push 'On-line SW' Write ? :Push 'Paper feed SW'	Normal printing (40 columns) Japanese
[ON LINE]	Dip SW-3	Setting of SW3
[FEED] [FEED] [FEED] [FEED] [FEED] [ON LINE] [ON LINE] [ON LINE]	(off)(off)(off)(off) (off)(on)(on)(on) Continue ? :Push 'On-line SW' Write ? :Push 'Paper feed SW'	Data bit length: 7 bits Parity permission: Even number Baud rate: 9600 bps
[FEED]	Dip SW setting complete!!	Complete setting

(2) Printing operation

- 1) Turn on the "ON LINE" lamp by pressing the [ON LINE] key, then start printing with the MF foot switch (option).
- 2) Turn off the "ON LINE" lamp by pressing the [ON LINE] key, then press the [FEED] key to feed paper.
- 3) Turn the power switch "ON" pressing the [FEED] key to start test printing.

(3) Connection

Connect each cable as figure below. Be sure that all power sources of each equipment are OFF when connecting cables.

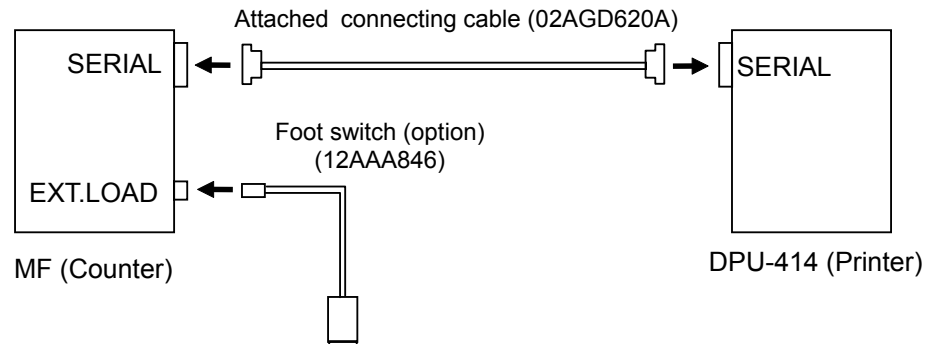

(4) Setting and operation of MF counter

① Setting

Default setting up of MF counter at shipment has no need to be changed, however, confirm the communication condition setting of MF counter if printing does not start.

② Printing operation

Pressing the foot switch (option) enables to print the value of the axis on which is set up output by MF counter.

6.7.6 Connecting QM-Data 200

It is necessary to perform the QM-Data 200 setting when connecting it to the counter unit.
For information about setting up QM-Dada 200, refer to its user's manual.

(1) Connection

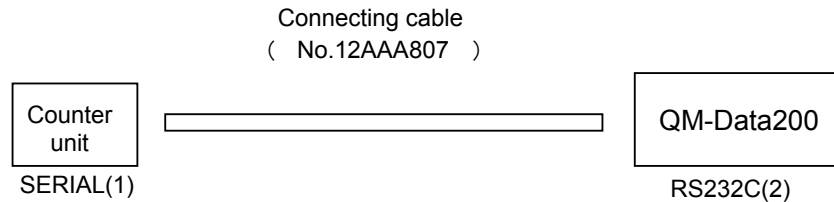

(2) QM-Data 200 setting

- ① Select the "SYSTEM" key of operation panel.
- ② 5: Measuring Instrument Setting--> 1: Counter Type--> MF-A/MF-UA

After the selection, the external counter setting of QM-Data 200 becomes the following communication condition:

- Baud Rate: 9600 bps
- Communication Condition: EVEN, 7, 1
- Flow Control: DTR/DSR
- Terminator: CR+LF

- ③ 2: Axis Configuration--> 1: X, Y or 2: X, Y, Z, (depending on the axis configuration of the microscope)

NOTE When QM-Data 200 starts, the counter display of microscope goes off and LED of mm/E display at the counter blinks on and off. The switches on the microscope counter become ineffective.

TIP A value in units of "E" is displayed by dividing a displacement in units of "mm" by 25.4.

6.8 External Dimensions

6.8.1 Main unit

(Unit : mm)

a) MF- * 505C

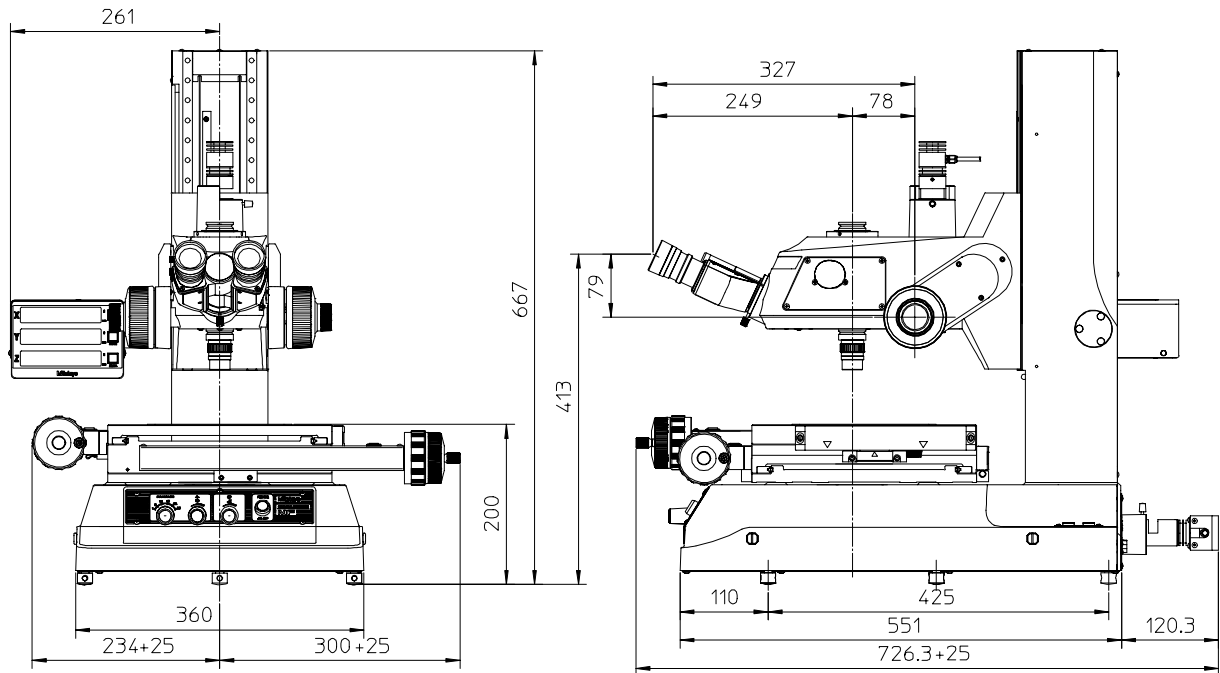

b) MF- * 1010C

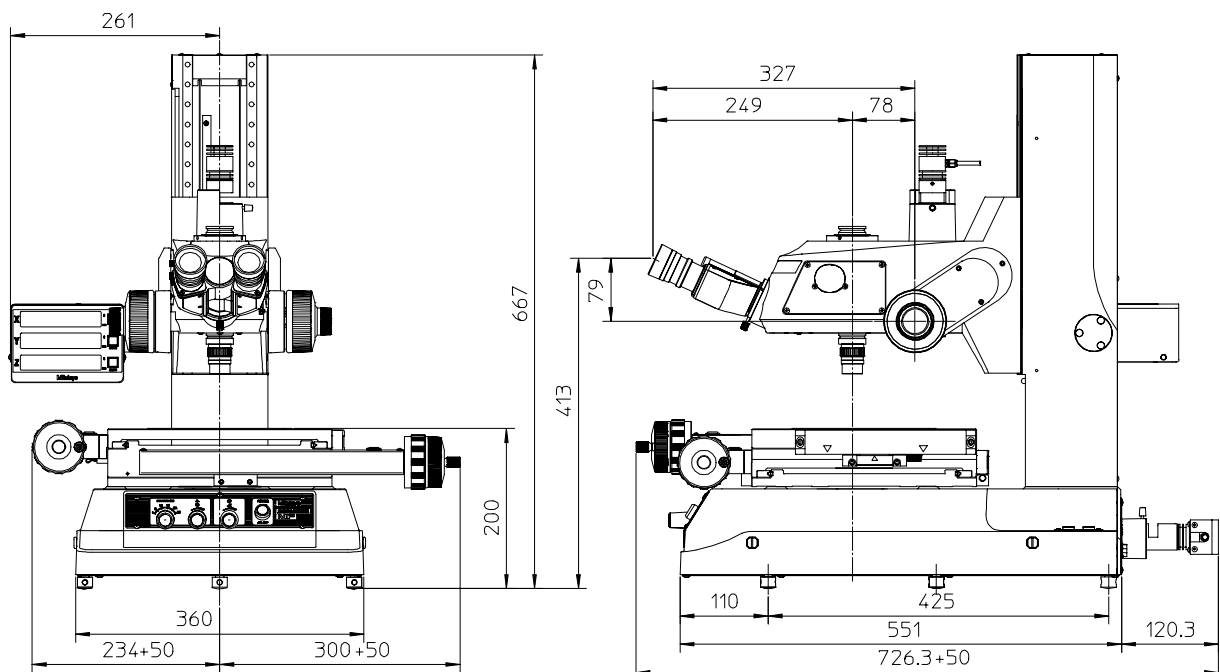

c) MF- * 2010C

(Unit : mm)

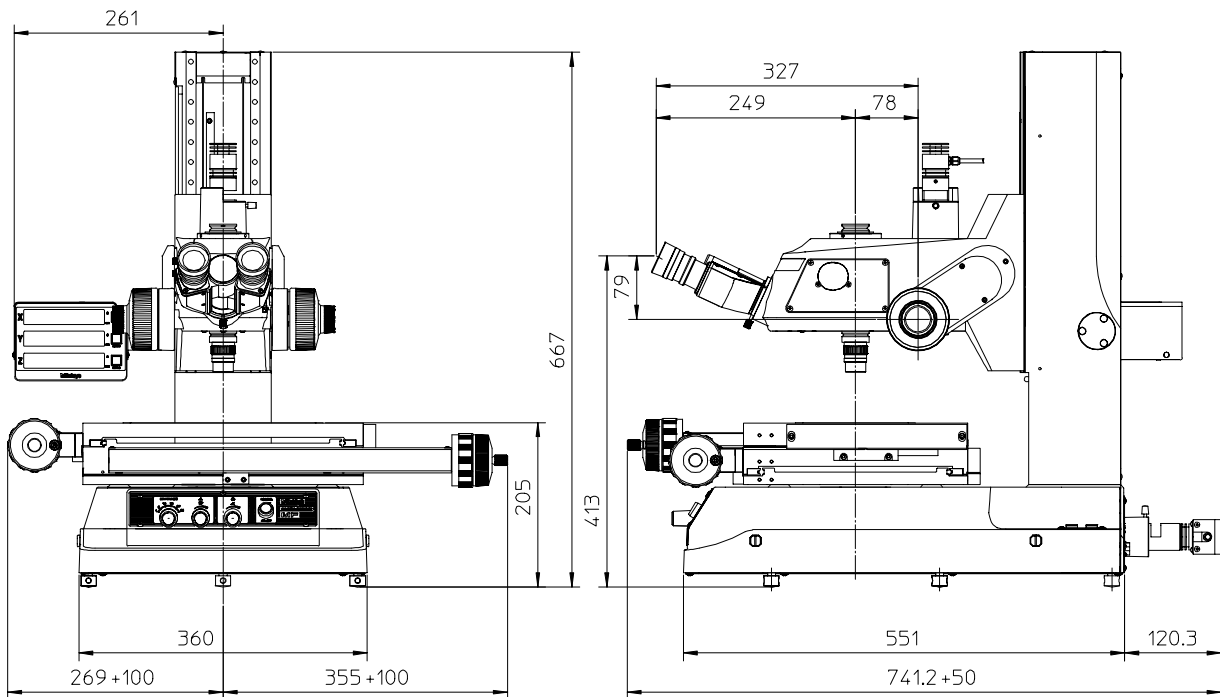

d) MF- * 2017C

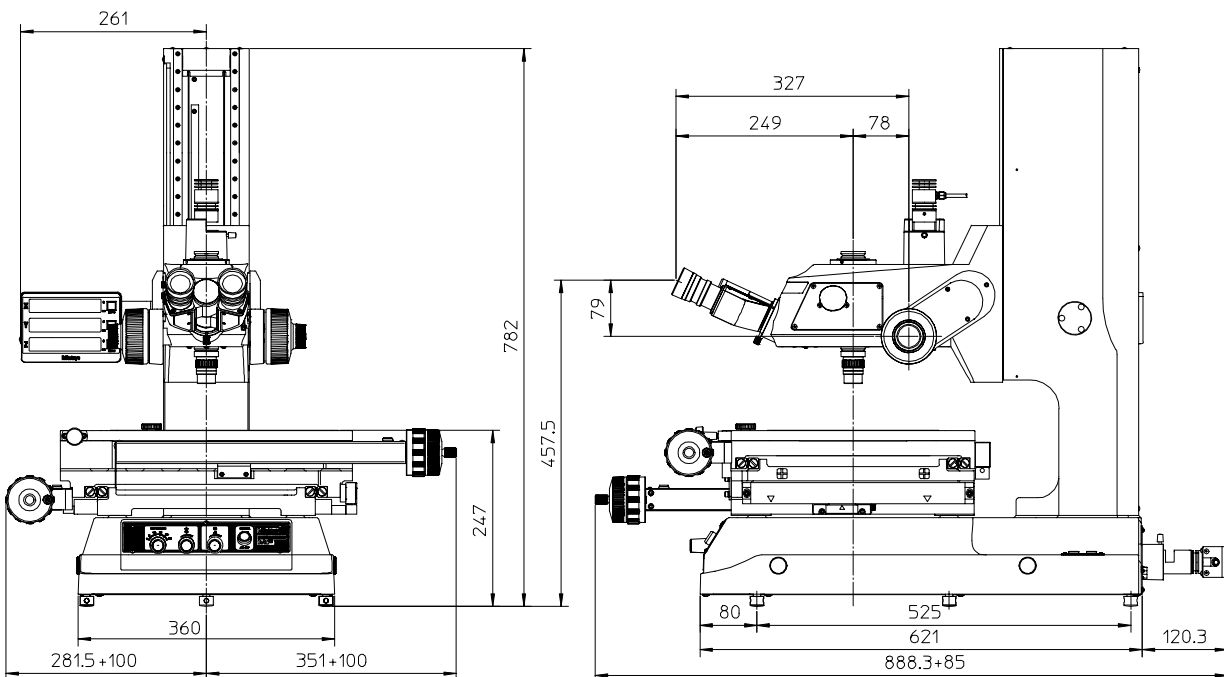

6. Specifications

e) MF- * 3017C

(Unit : mm)

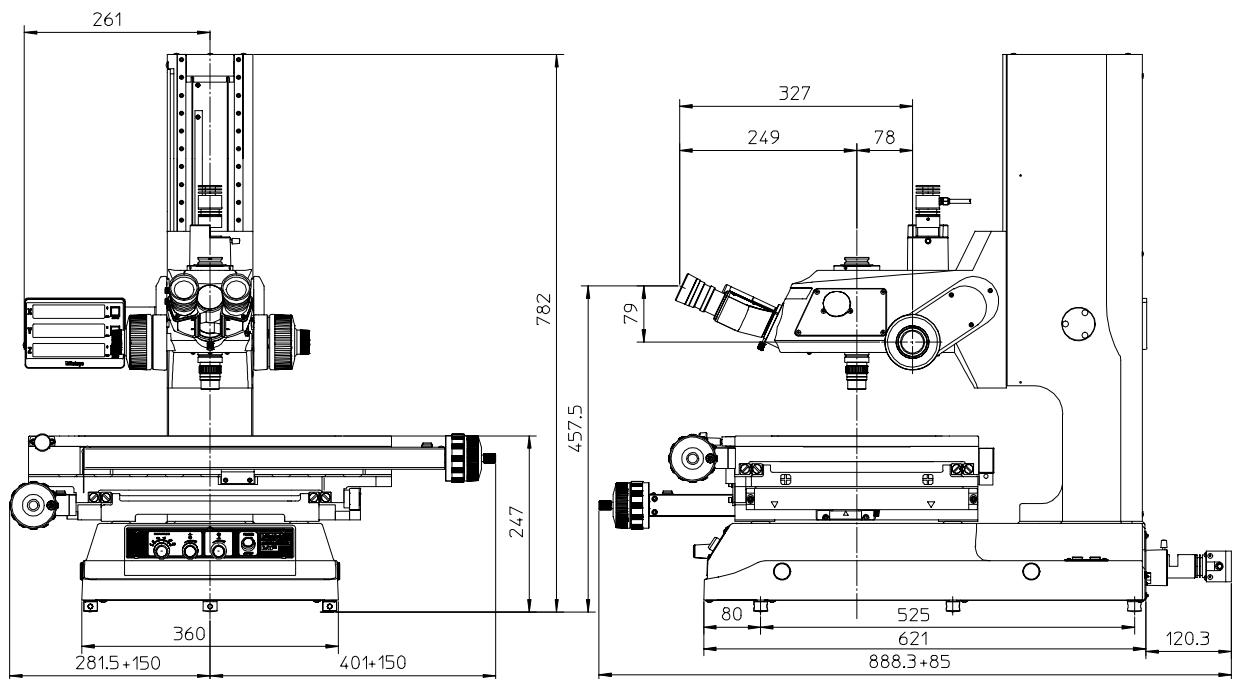

f) MF- * 4020C

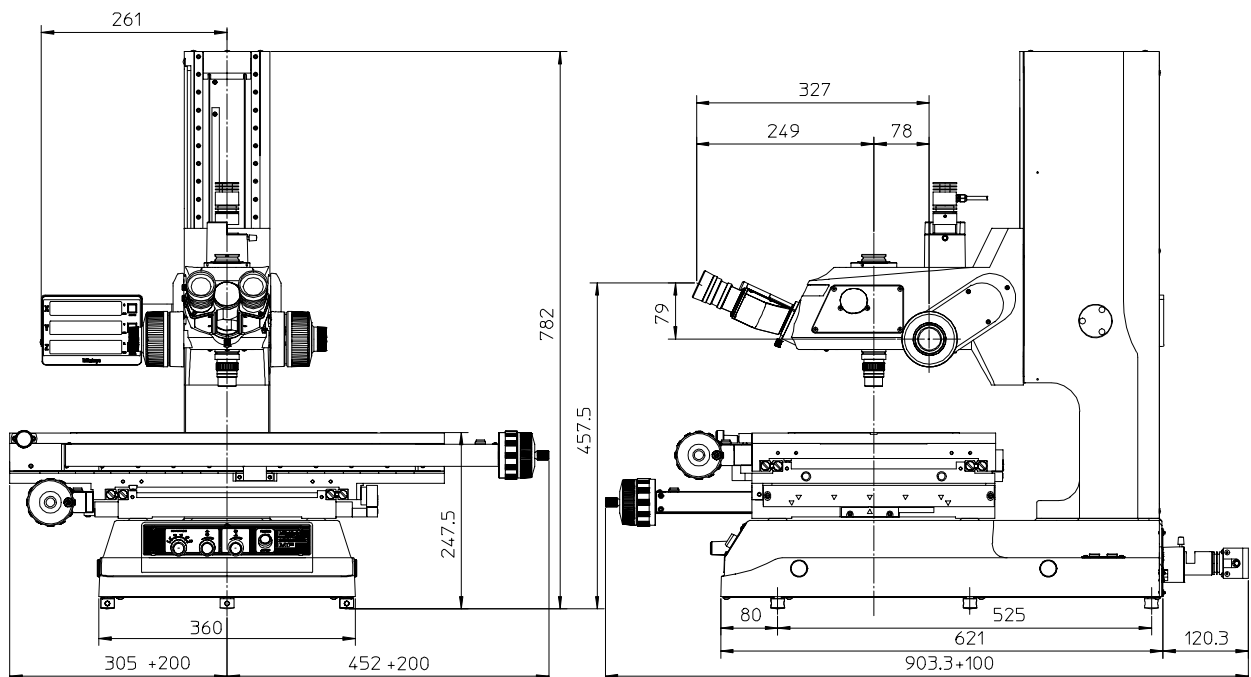

6.8.2 Control unit

(Unit: mm)

a) LED illuminator

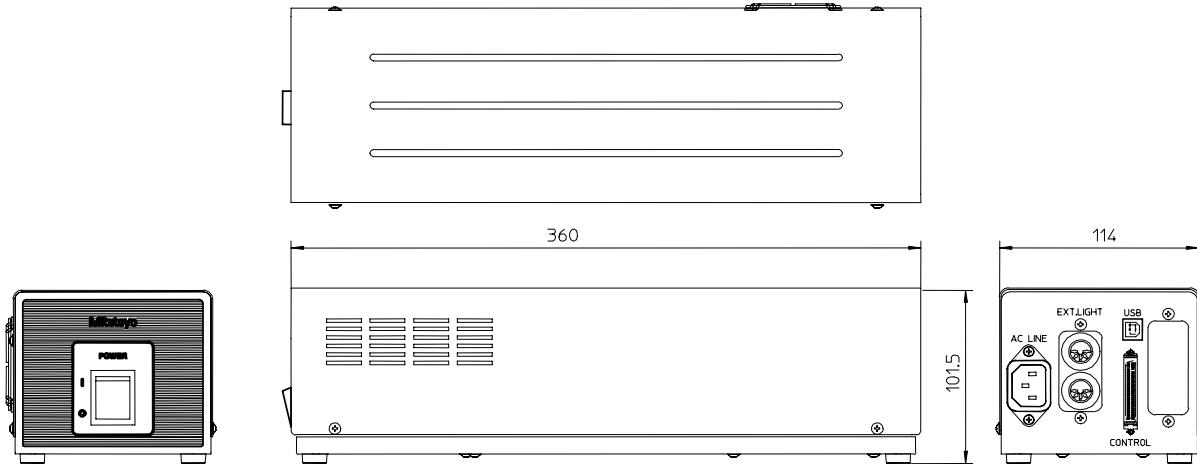

b) Halogen illuminator

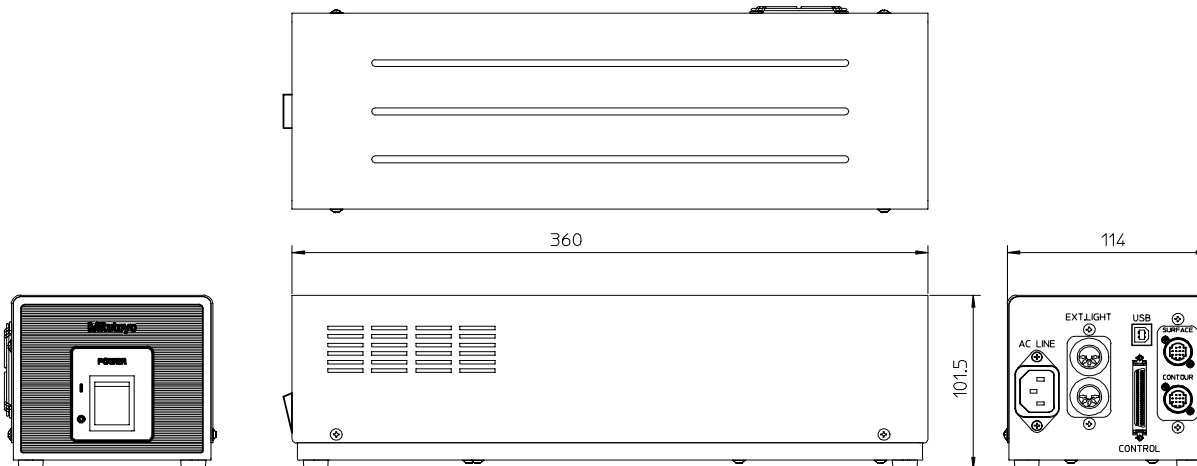

6.8.3 Cross-travel stage

(Unit : mm)

- a) MF- * 505C
- b) MF- * 1010C

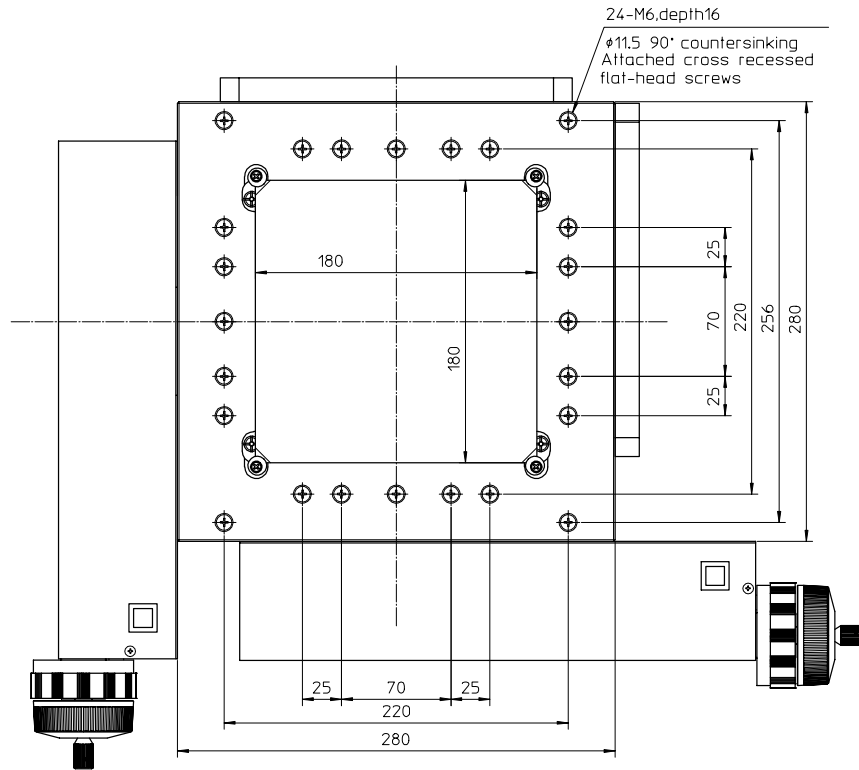

- c) MF- * 2010C

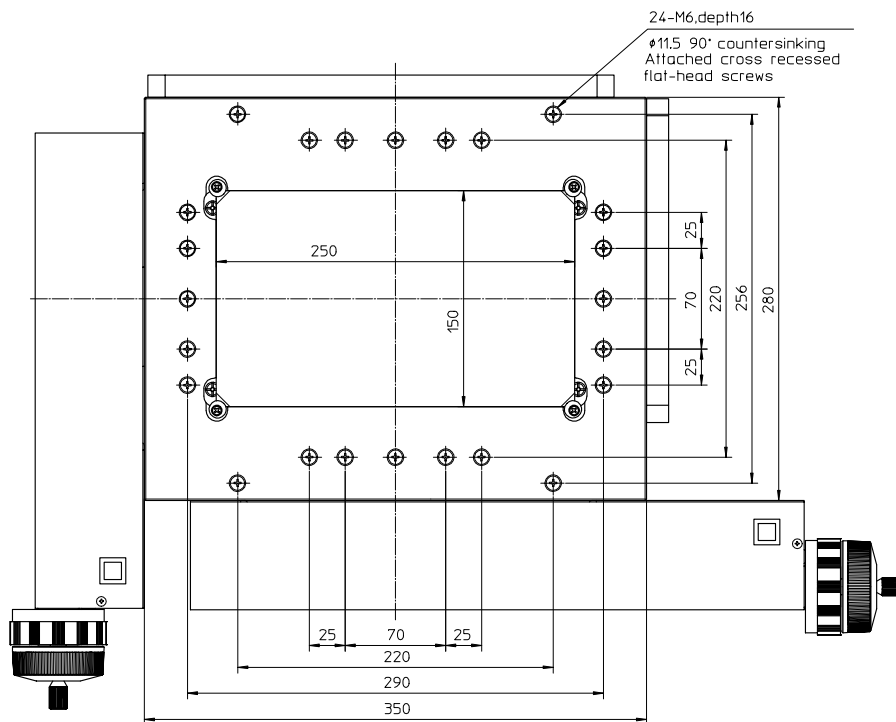

d) MF- * 2017C

(Unit : mm)

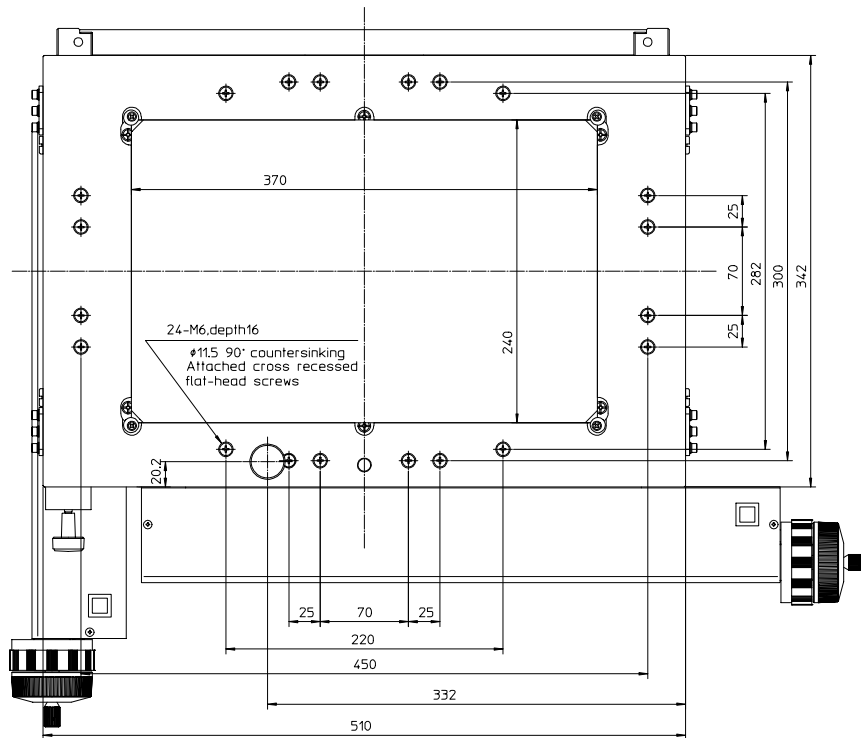

e) MF- * 3017C

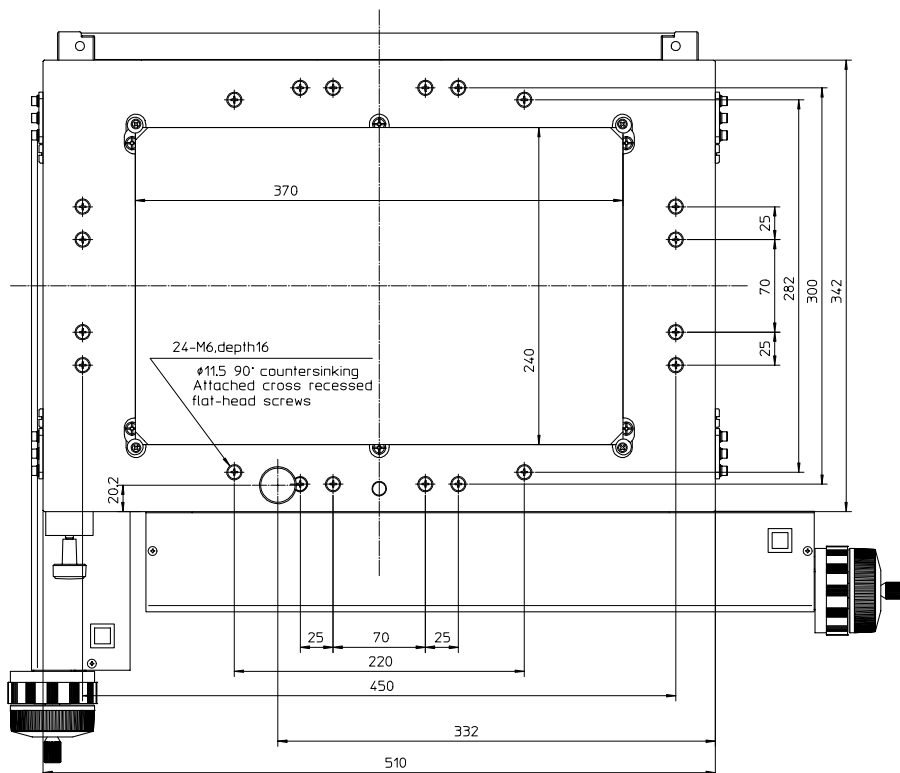

f) MF- * 4020C

(Unit : mm)

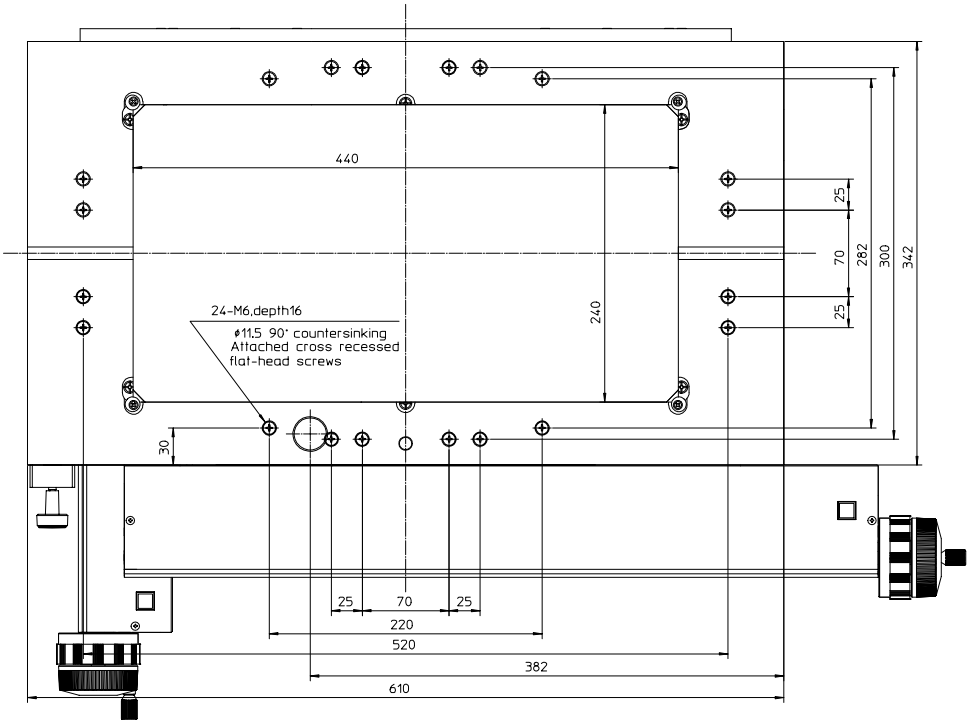

MEMO