

Measuring Microscope MF-U series

Measuring Microscope MF-U series

User's Manual (Hardware Guide)

Read this User's Manual thoroughly
before operating the instrument. After reading,
retain it close at hand for future reference.

Mitutoyo

CONVENTIONS USED IN THIS MANUAL

Safety Precautions

To ensure that instruments are operated correctly and safely, Mitutoyo manuals use various safety symbols (Signal Words and Safety Alert Symbols) to identify and warn against hazards and potential accidents.

The following signs indicate **general** warnings:



Indicates an imminently hazardous situation which, if not avoided, will result in serious injury or death.



Indicates a potentially hazardous situation which, if not avoided, could result in serious injury or death.



Indicates a potentially hazardous situation which, if not avoided, may result in minor or moderate injury or property damage.

The following signs indicate **specific** warnings or prohibited actions, or indicate a mandatory action:



Alerts the user to a specific hazardous situation. The given example means "Caution, risk of electric shock".



Prohibits a specific action. The given example means "Do not disassemble".



Specifies a required action. The given example means "Ground".

CONVENTIONS USED IN USER'S MANUAL

Various Types of Notes

The following types of **notes** are provided to help the operator obtain reliable measurement data through correct system operation.

-
- IMPORTANT**
- An *important* note is a type of note that provides information essential to the completion of a task. You cannot disregard this note to complete the task.
 - An *important* note is a type of precaution, which if neglected, could result in a loss of data, decreased accuracy or instrument malfunction/failure.
-

NOTE A *note* emphasizes or supplements important points of the main text. A *note* supplies information that may only apply in special cases (e.g., Memory limitations, equipment configurations, or details that apply to specific versions of a program).

TIP A *tip* is a type of note that helps the user apply the techniques and procedures described in the text to their specific needs.

It also provides reference information associated with the topic being discussed.

Mitutoyo assumes no liability to any party for any loss or damage, direct or indirect, caused by use of this instrument not conforming to this manual.

Information in this document is subject to change without notice.

© 2009 Mitutoyo Corporation. All rights reserved.

Notes on LED Safety

An LED is integrated into the illuminator in this measuring microscope, MF/MF-U series. Please observe the following to use the product in a safe manner. Operations other than described in the manual may result in dangerous radiant exposure.



CAUTION

- 1) The JIS (JIS C 6802, established in 2005) and the International Standard (IEC60825-1, established in 2001) are the safety standards for LED devices.
 - 2) The LED device is classified as “Class 1 LED product” in the JIS and IEC standards.
 - 3) Do not look into LED light.
(Never look into LED light even when light is not emitted.)
 - 4) Do not look at laser light directly with an optical instrument (light condensing device such as a magnifying glass).
 - 5) Skin exposure to LED light causes no problem.
-

Precautions for Use

- **This instrument is a measuring machine.**

Do not use this instrument for any purpose other than such measurement.

- **This instrument is a precision machine.**

Exercise great care when handling this machine. Never bump or apply excessive force to any of the parts during operation.

- **Rectify the installation environments.**

(For detailed information, refer to “Installation Environments”.)

- Close to 20°C in ambient temperature.
- Free of extreme humidity.
- Free of dust and dirt.
- Free of vibration.

- **Gently fix a workpiece on the stage.**

If the stage glass or top face is subject to large impact, it could be damaged. Exercise sufficient care in fixing a workpiece or a jig.

Particularly, pay attention so as not to apply an impact to the stage glass.

- **Turn off the power during connection and maintenance.**

To avoid accidents or electric shock due to malfunction of the machine under operation, be sure to turn off the power before performing connection or maintenance.

- **Please do not carry the measurement thing of 18kg or more alone.**

Please do not carry the measurement thing to exceed 18kg alone for safety though the maximum authorized freight mass of the stage is 20kg.

- **Power supply**

Observe the following precautions regarding the power supply.

- As a rule, the power distribution method should be a single-phase, two wire system with one wire grounded. (Pay due attention to the polarity.)
- Be sure to ground the system. (Protective grounding) (Class D grounding) * Consult a qualified electrician or someone with equivalent knowledge for the power supply arrangement and construction.

- **Turn the power switch ON or OFF along the order**

The counter may display error messages (E51,E52,E53) by the order which turns the power supply of the microscope main unit and the peripheral equipment such as personal computer on or off in the connection with some peripheral equipment, when the peripheral equipment is being connected with the counter unit at RS232C.

Be sure to perform at the following order, when turning the power switch ON or OFF.

- For ON ····· **Peripheral equipment** → **Microscope main unit**
- For OFF ····· **Microscope main unit** → **Peripheral equipment**

- **Power cord**

Use only the power cord supplied with this product. Please contact us if an abnormality is observed on the power cord or power connector.

- **Removing the cover and disassembling the machine**

This machine is precisely adjusted, and is comprised of high-voltage parts. In order to prevent accident and to maintain the performance, do not absolutely remove the cover on the machine.

- **Danger prevention**

In order to prevent danger, do not use the machine in locations where volatile gases could be generated.

- **Maintenance**

Gently wipe off dirt from the machine using a lint-free and soft cloth. If the dirt is difficult to remove, wipe it clean with a cloth soaked in neutral detergent, then wipe lightly with a dry cloth or a cloth well-wrung after soaking in water. Do not use organic solvents such as thinner or benzene.

- **Take special shielding measures when using the machine in the following locations:**

- Where noise is generated due to static electricity
- Near strong electric fields
- Where power source lines pass nearby
- Where there is a risk of radioactivity
- Where the machine could be subject to corrosive gasses

Installation Environments

Temperature

This measuring microscope has been assembled and adjusted in the temperature-controlled room at 20°C. To use the microscope at the rated measuring accuracy in the specification, the temperature at the installation site should be close to 20°C with minimum temperature fluctuation. (The ideal temperature is standard temperature condition level 1, 20°C ± 1°C, that is specified as “Standard Condition of Precision Measurement Environments” in JMAS5011.) Also, the temperature gradient should be 2°C as reference for 8 hours. If this temperature environment is worse than the above condition, the microscope may not meet the specified measuring accuracy. Even if the specified accuracy is temporarily obtained by adjustment, uncertain measurements will be displayed at 20°C.

Humidity

Humidity is not directly related to the measuring microscope accuracy. If the ambient humidity is high, rust will easily form on important machined surfaces and may affect electronic parts adversely. Efforts should be made to retain humidity between 55 and 65%.

Dust and dirt

The measuring microscope consists of high-precision parts such as guide ways, linear scale units, and optical units that are apt to be easily damaged by dust and dirt. Use the microscope at a site free of dust and dirt.

Grounding

To operate the measuring microscope properly, be sure to connect the GND terminal to the earth terminal with a grounding resistance of 100Ω or less (conforming to Class 3 grounding construction). Also, if a system is to be configured along with other instruments, make sure all the instruments are properly grounded at the power supply with a complete ground terminal, and then connect the signal cables between them.

System Environments

Place	The indoor use
Use altitude	2000m or less
Use temperature	5~40°C
Use humidity	80%or less (There must not be dewy.)

Preservation environments

Preservation temperature	-10~50°C
Preservation humidity	80%or less (There must not be dewy.)

WARRANTY

This measuring microscope has been manufactured under Mitutoyo's rigorous quality control system. In the event that this instrument should fail within one year from the original date of purchase through normal use, we will repair or replace it at our option, free of charge, upon its prepaid return to Mitutoyo. Contact your dealer or the nearest Mitutoyo Service Center.

However, the following failure or damage may be subject to a repair charge even within the warranty period:

- 1 Unit failure or damage arising from improper handling, or unauthorized retrofit or repair by the user.
- 2 Unit failure or damage as the result of moving, dropping, or transporting after purchase.
- 3 Unit failure or damage due to fire, salt, gas, abnormal voltage, or natural catastrophe.

This Warranty is valid only in the country of original purchase.

Notes on Overseas Transfer

This product is controlled by the Export Control Regulations. Please contact Mitutoyo before transferring it abroad.

Before exporting this product confirm the final purpose of use at the export destination to prevent the product from being used for developing weapons of mass destruction or military affairs.

Disposal of Old Electrical & Electronic Equipment (Applicable in the European Union and other European countries with separate collection systems)



This symbol on the product or on its packaging indicates that this product shall not be treated as household waste. To reduce the environmental impact of WEEE (Waste Electrical and Electronic Equipment) and minimize the volume of WEEE entering landfills, please reuse and recycle.

For further information, please contact your local dealer or distributors.

CONTENTS

CONVENTIONS USED IN THIS MANUAL	i
Notes on LED Safety	iii
Precautions for Use	iiv
Installation Environments	vi
System Environments	vi
Preservation environments	vi
WARRANTY	vii
Notes on Overseas Transfer	vii
Disposal of Old Electrical & Electronic Equipment (Applicable in the European Union and other European countries with separate collection systems) ..	vii
1 Overview	1-1
1.1 Outline	1-1
1.2 Name and Function of Each Part	1-2
1.2.1 Optical tube unit.....	1-4
1.2.2 Cross-travel stage unit	1-5
1.2.3 Illuminator unit	1-6
1.2.4 DRO counter unit	1-8
1.2.5 Illuminator.....	1-15
2 Installation and Setup	2-1
2.1 Installation.....	2-1
2.2 Remove the Fixing Plate	2-2
2.2.1 Removing the fixing plate for cross-travel stage	2-2
2.2.2 Removing the fixing plate for optical tube unit	2-3
2.3 Moving the Table on the Cross-Travel Stage	2-4
2.3.1 When a great and quick travel of the table is required	2-4
2.3.2 When a fine travel of the table is required.....	2-4
2.4 Moving the Optical Tube Unit	2-5
2.4.1 When a great and quick travel of the unit is required	2-5
2.4.2 When a fine travel of the unit is required	2-5
2.5 Leveling the Main Unit	2-6
2.6 Attaching a Revolver	2-7
2.7 Mounting the Lenses.....	2-8
2.7.1 Mounting the objective.....	2-8
2.7.2 Mounting the eyepieces	2-8
2.8 Installation of the Illuminators	2-9
2.8.1 Transmitted illuminator	2-9
2.8.1.1 For LED illuminator	2-9
2.8.1.2 For halogen illuminator.....	2-10

2.8.2	Reflected illuminator	2-11
2.8.2.1	For LED illuminator	2-11
2.8.2.2	For halogen illuminator	2-12
2.9	Changing the Counter Mounting Angle and Position.....	2-13
2.10	Connecting Each Part.....	2-14
①	Microscope main unit.....	2-14
②	100 W fiber-optic illuminator	2-15
③	150 W fiber-optic illuminator	2-15
3	Measurement Setup.....	3-1
3.1	Connection Check.....	3-1
3.2	Turning the Power Supply On	3-1
3.3	Confirming the Filament Position of the Transmitted Illuminator (only for halogen illuminator).....	3-2
3.3.1	Confirming the position of the filament for Transmitted illuminator	3-2
3.4	Adjusting the Aperture for Transmitted Illumination	3-3
3.5	Adjusting the Aperture for Reflected Illumination	3-5
3.5.1	Adjusting the aperture diaphragm for the illumination	3-5
3.5.2	Centering the aperture diaphragm.....	3-6
3.6	Aligning the Visual Field Center	3-7
3.7	Replacing the Objective.....	3-7
3.8	Setting Up a Workpiece	3-8
3.9	Selecting the Illumination Method.....	3-10
3.9.1	Transmitted illumination	3-10
3.9.2	Vertical reflected illumination.....	3-10
3.9.3	Simultaneous use of transmitted and vertical reflected illumination	3-10
3.10	Selecting a Filter.....	3-11
3.11	Adjusting the Pupil Distance.....	3-12
3.12	Adjusting the Diopter of Eyepiece.....	3-13
3.13	Replacing the Reticle	3-13
3.14	Dimensional Measurement.....	3-14
3.15	Polarized Observation	3-15
3.16	Differential Interference Observation.....	3-16
3.17	Switching Bright/Dark-Field Reflection Observation (Applied only to the bright/dark-field type).....	3-17
4	Maintenance	4-1
4.1	Cleaning External Parts	4-1
4.2	Maintaining the Lens.....	4-1
4.3	Replacing Consumables.....	4-2
4.3.1	Replacing halogen bulbs for Transmitted illuminator	4-2
4.3.2	Replacing halogen bulbs for Reflected illuminator	4-3
4.3.3	LED illuminator replacement.....	4-4
4.3.4	Replacing the stage glass.....	4-5
4.3.5	Replacement of conston spring.....	4-6

5	Troubleshooting	5-1
5.1	Main Unit.....	5-1
5.2	Counter Unit.....	5-2
5.3	Illuminator and Concerned Matters	5-3
5.4	Error Messages and Remedies	5-4
5.4.1	Counter and concerned matters.....	5-4
5.4.2	Illuminator and concerned matters	5-5
6	Specifications	6-1
6.1	Specifications	6-1
6.2	Standard Accessories	6-2
6.2.1	Standard accessories for measuring microscope main unit	6-2
6.2.2	Standard accessories for illuminator.....	6-2
6.3	List of Consumables	6-3
6.4	Optional accessories	6-4
6.5	Objectives, Tube Lens, Eyepieces Specification Table	6-6
6.6	Layout of the Optical System	6-8
6.7	Serial Data Output Specifications of the Counter	6-9
6.7.1	Connector specifications	6-9
6.7.2	Control signal.....	6-9
6.7.3	Data output operation.....	6-11
6.7.4	Connecting Micropak.....	6-13
6.7.5	Connecting DPU-414 (Printer)	6-14
6.7.6	Connecting QM-Data 200.....	6-16
6.8	External Dimensions	6-17
6.8.1	main unit	6-17
6.8.2	Control unit.....	6-20
6.8.3	Cross-travel stage.....	6-21

SERVICE NETWORK

1

Overview

This chapter describes the system configuration, and the name and function of each part on the MF-U series Measuring Microscope.

1.1 Outline

The Mitutoyo MF-U series Measuring Microscope is a multi-purpose measuring microscope for factory inspection use. It can perform precision measurement of workpiece dimensions, contours and surface features. The MF-U series can be used in a wide range of applications in combination with a variety of accessories. It is possible to improve the system according to a specific purpose.

The MF-U series has the following features.

- Twisted roller is incorporated in the quick release mechanism. It allows smooth operation and eliminates the impact when switching coarse / fine feed.
- The cross-travel stage with a maximum stroke of 400 X 200mm is available as an option.
- Both right and left side of the optical tube unit is equipped with the coaxial fine / feed focusing wheels. This makes focusing operation easy.
- High-resolution measurement is supported using the counter with a resolution of 0.1 μ m (selectable from 0.1/0.5/1 μ m).
- Select either the LED type or halogen type for the illuminator.
(Either of the illuminators is a requisite selection option.)
- The LED illuminator has a long operating life (approx. 30,000 hours) and provides clear object views because lighting adjustment of the LED illuminator does not create any change in color temperature.

NOTE To use the measuring microscope safely, read "Safety Precautions" in this manual prior to use and observe the precautions.

1.2 Name and Function of Each Part

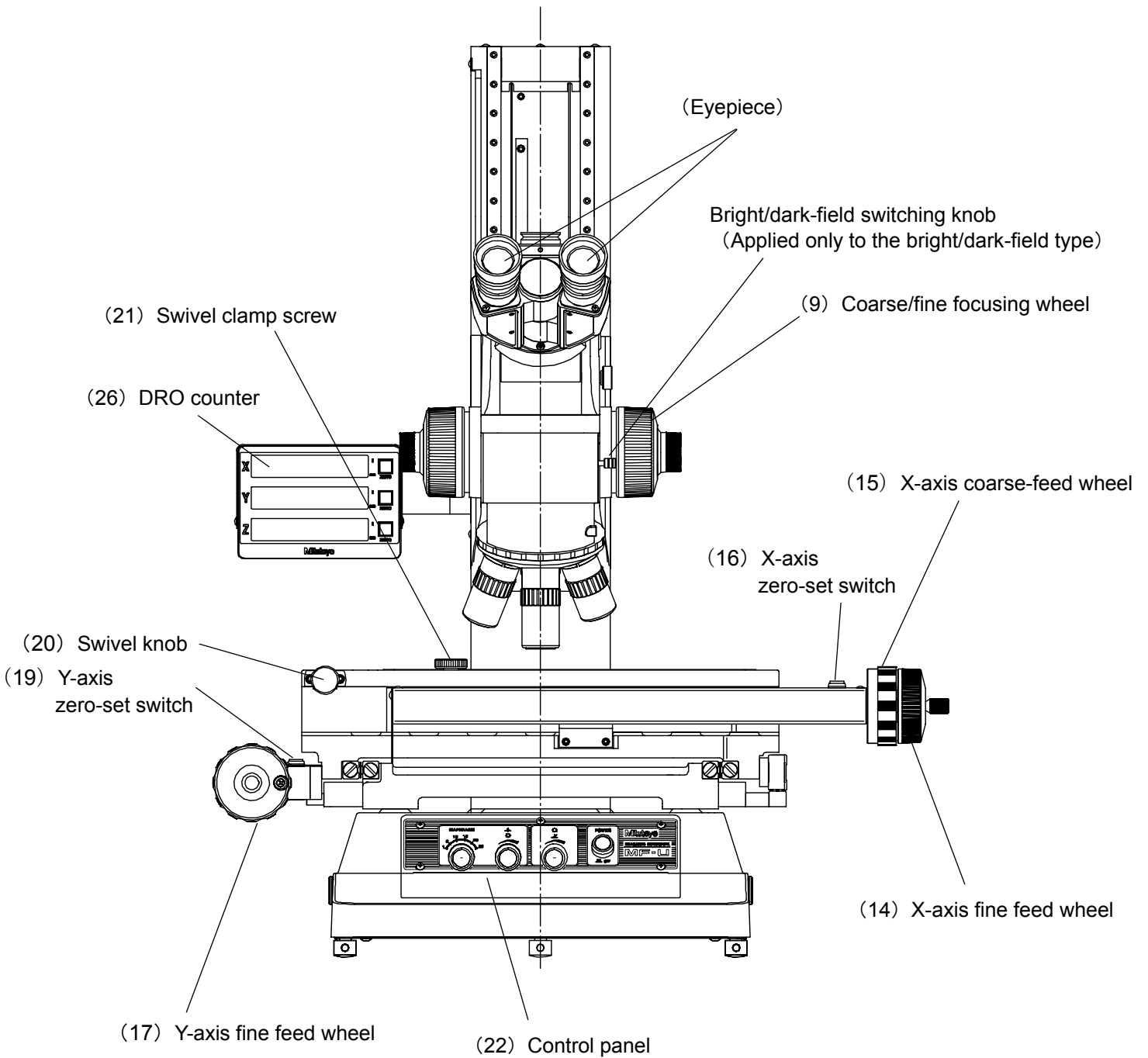

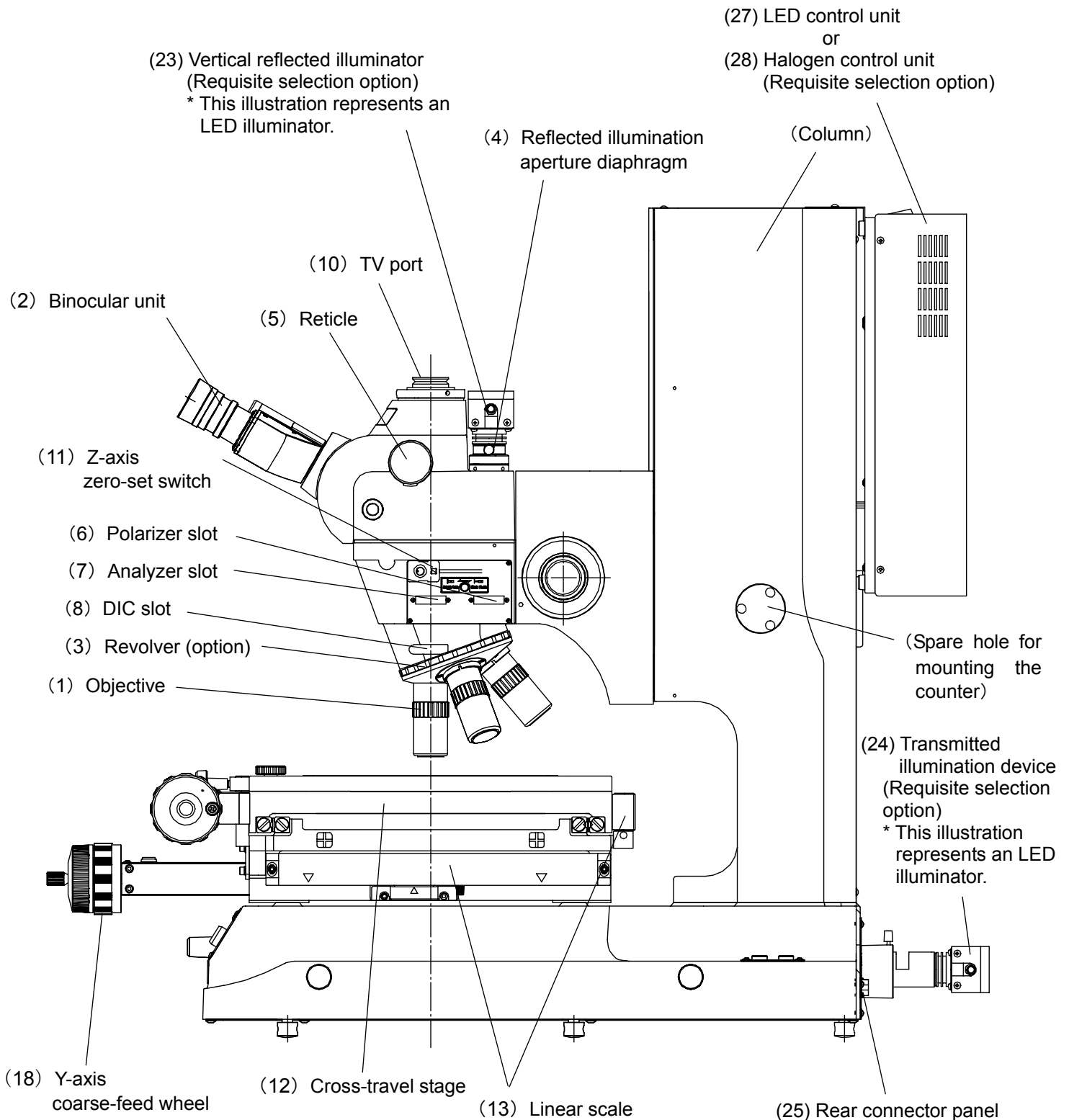

1.2.1 Optical tube unit

- 1) **Objective (option)** : 1X to 200X objectives are available as options. Selects according to the application. (2X to 100X for Bright-Field/Dark-Field)
- 2) **Binocular unit** : A 10x eyepiece is mounted. A relay lens system is used in which a cross-hair reticle is installed in optical tube. The cross-hair in the tube is not shifted even by the pupil distance adjustment.
- 3) **Revolver (option)** : Used to switch a desired objective. Allows a maximum of four bright-field objectives between 1X and 200X to be mounted. Power revolver and adjustable revolver, etc. are available as options. Selects according to the application.
- 4) **Reflected illumination aperture diaphragm** : Adjusts the numerical aperture of the illumination system by turning the lever.

TIP **What is Aperture diaphragm?**.....A diaphragm for controlling the light beam of an illumination system. The resolution, contrast, and depth of focus of an optical system are dependent on this aperture diaphragm. Adjust the diaphragm to the appropriate numerical aperture.

NOTE For information about adjusting the aperture diaphragm, refer to the instructions given in "3.5 Adjusting the aperture for reflected illumination".

NOTE The fiber-optic illuminator is an optional accessory. Select 100W fiber-optic illuminator (No.176-315) or 150W fiber-optic illuminator (No.176-316) according to its use.

- 5) **Reticle** : Remove the cover made of rubber. You will see the broken cross-hair reticle with the standard line width of 5 μ m is mounted inside.
- 6) **Polarizer slot** : Slot for inserting a polarizer or a BF/DF switching slide (for BF/DF observation) . The polarizing direction is fixed.
- 7) **Analyzer slot** : Slot for inserting an analyzer. The polarizing direction of the analyzer can be rotated up to 360°.
- 8) **DIC (differential interference contrast) slot** : Slot for inserting a DIC unit.
- 9) **Coarse/fine focusing wheel** : This focusing wheel allows coarse or fine vertical travels of the optical tube for focusing. The travel range and adjustments are given below.
 - Vertical travel range : 150 mm (for MF-U * 505C, MF-U * 1010C, MF-U * 2010C)
220 mm (for MF-U * 2017C, MF-U * 3017C, MF-U * 4020C)
 - Coarse adjustment : 10 mm per knob rotation
 - Fine adjustment : 0.1 mm per knob rotation
- 10) **TV port** : Used for mounting optional accessories (e.g. TV camera or Focus Pilot) .
- 11) **Z-axis zero-set switch** : A switch for zero-setting a Z-axis display value on the counter.

-
- IMPORTANT**
1. When operating this switch, do not touch it with wet hand. A trouble may result.
The X-axis and Y-axis zero-set switch should be treated likewise.
 2. A magnet is attached to the bottom surface of the Z-axis zero-set switch. It is possible to remount the switch with a single touch on a location where the switch can be operated easily.
-

TIP A magnet is attached to the bottom surface of the Z-axis zero-set switch. Therefore, the switch can be moved to an operator-friendly position with a single motion.

1.2.2 Cross-travel stage unit

IMPORTANT The stage glass is made of glass to transmit the transmitted illumination light.
Do not bump the stage glass when installing a workpiece on it. If placing a heavy workpiece with protrusions on the stage glass, exercise attention so as not to scratch the glass.

- 12) **Cross-travel stage** : Mounts a workpiece on this stage; its stroke varies depending on the MF-U model.
- MF-U * 505C 50mmX 50mm
 - MF-U * 1010C 100mmX100mm
 - MF-U * 2010C 200mmX100mm
 - MF-U * 2017C 200mmX170mm (with swivel table)
 - MF-U * 3017C 300mmX170mm (with swivel table)
 - MF-U * 4020C 400mmX170mm (with swivel table)
-

TIP The MF-U * 505C, MF-U * 1010C and MF-U * 2010C models have no table rotating mechanism on the cross-travel stage. If necessary, use the optional fine-feed rotary table (A) (No.176-305). The fine-feed rotary table (B) (No.176-306) is also available as an option for the MF-U * 2017C, MF-U * 3017C and MF-U * 4020C models. Use the rotary table as necessary.

- 13) **Linear scale** : Three pieces of Linear scale are mounted on each of the X- and Y-axis of the cross-travel stage and the Z-axis column. The displacement of the stage and optical tube unit is displayed on the DRO counter.
- 14) **X-axis fine feed wheel** : Used to finely move the cross-travel stage along the X-axis direction.
- 15) **X-axis coarse-feed wheel** : Used to quickly move the cross-travel stage along the X-axis direction.
- 16) **X-axis zero-set switch** : A switch for zero-setting a X-axis display value on the counter.
- 17) **Y-axis fine feed wheel** : Used to finely move the cross-travel stage along the Y-axis direction.

-
- 18) **Y-axis coarse-feed wheel** : Used to quickly move the cross-travel stage along the Y-axis direction.
 - 19) **Y-axis zero-set switch** : A switch for zero-setting a Y-axis display value on the counter.
 - 20) **Swivel knob** (for MF-U * 2017C, MF-U * 3017C, and MF-U * 4020C): Swivels the XY stage up to $\pm 5^\circ$ or $\pm 3^\circ$. (MF-U * 505C, MF-U * 1010C, and MF-U * 2010C are not equipped with this knob.)
 - 21) **Swivel clamp screw** (for MF-U * 2017C, MF-U * 3017C and MF-U * 4020C) : Used to fix the XY stage up swiveled. (This screw is not provided for the MF-U * 505C, MF-U * 1010C and MF-U * 2010C models.)
-

- NOTE**
1. Do not turn the swivel knob by force with the swivel clamp screw tightened up. A trouble may result.
 2. If a workpiece and optional accessories are interfered with the swivel clamp screw, replace the swivel clamp screw with the button head screw which is the attachment.
-

1.2.3 Illuminator unit

- 22) **Control panel:** Consists of the switch to start the main unit and the knobs to control illumination and the aperture of transmitted illumination.

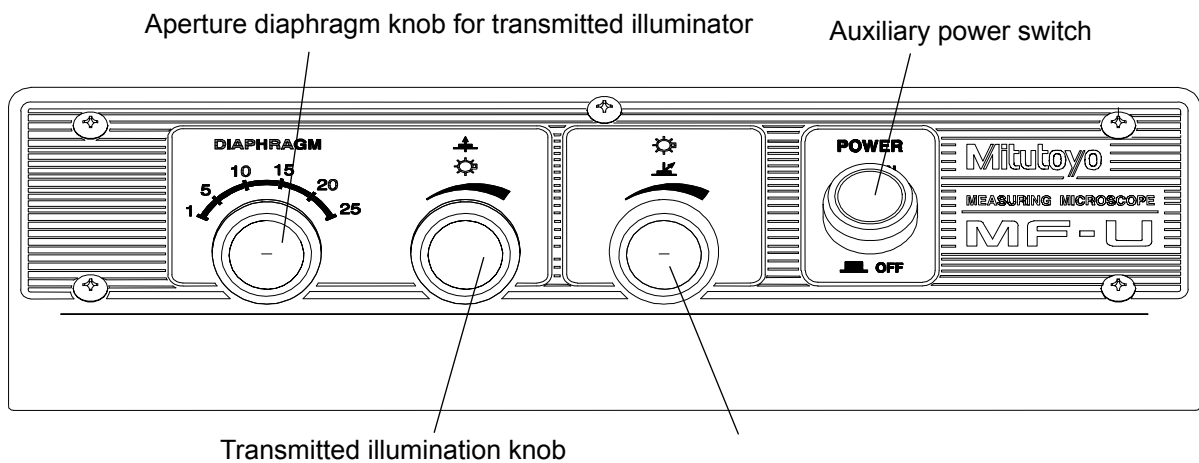

-
- TIP** Aperture diaphragm: A pencil of rays in the light system is controlled, which is associated with the resolving power, contrast, and focal depth of the optical system. Adjust the diaphragm to the optimal numerical aperture.
-

- NOTE**
1. For information about adjusting the aperture diaphragm, refer to the instructions given in "3.4 Adjusting the aperture for transmitted illumination".
 2. Even when the auxiliary power switch is turned off, feeble power is consumed.
If you do not use the product for a long time, please turn off the main power of the control unit.
-

- 23) **Vertical reflected illuminator (requisite selection option):** Lighting device for measurement of workpiece surface. According to your choice, either LED illumination or fiber light source is placed.
- For the LED illuminator, plug into the connector that indicates “SURFACE” on the rear panel. Two filters can be attached to the illuminator.
 - For the halogen illuminator, adjustment of the volume on the fiber light source unit allows light to be controlled. Connection of “external light source control cable” from the optional accessories to “DIN connector 2” of the illuminator (control unit) allows light to be controlled on the control panel.
- 24) **Transmitted illuminator (requisite selection option):** Lighting device for measurement of workpiece contour. According to your choice, either LED illuminator or halogen illuminator is placed.
- For the LED illuminator, plug into the connector that indicates “CONTOUR” on the rear panel. Two filters can be attached to the illuminator.
 - For the halogen illuminator, plug into the connector that indicates “CONTOUR” of the illuminator (control unit). Two filters can be attached to the illuminator.

- NOTE**
1. For information about replacing halogen bulbs, refer to the instructions given in "4.3.1 Replacing halogen bulbs".
 2. For information about replacing LED bulbs, refer to the instructions given in "4.3.3 Replacing LED bulbs".

- 25) **Rear panel:** Consists of the connectors to be connected to the control unit, transmitted illuminator, and reflected illuminator.

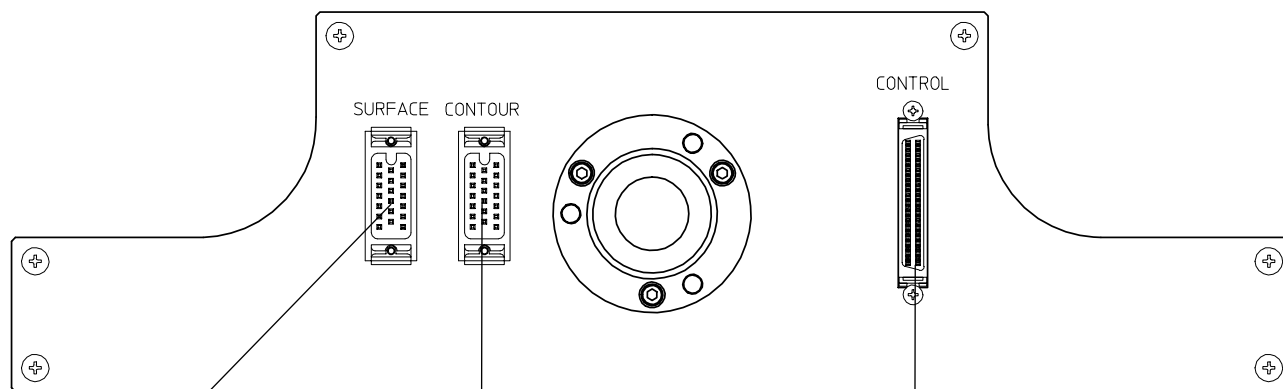

- b) Connector for vertical reflected illuminator (LED) c) Connector for transmitted illuminator (LED) a) Connector for control cable

a) Connector for control cable

This connector is used to connect the cable to an LED or halogen control unit.

b) Connector for vertical reflected illuminator (LED)

This connector is used to connect an LED type vertical reflected illuminator. (To connect a fiber light source, this connector is not used.)

c) Connector for transmitted illuminator (LED)

This connector is used to connect an LED type transmitted illuminator. (To connect a halogen type transmitted illuminator, this connector is not used.)

1.2.4 DRO counter unit

26) **Counter** : The displacement of cross-travel stage and optical tube unit is displayed on this counter.

① **Front view of the counter**

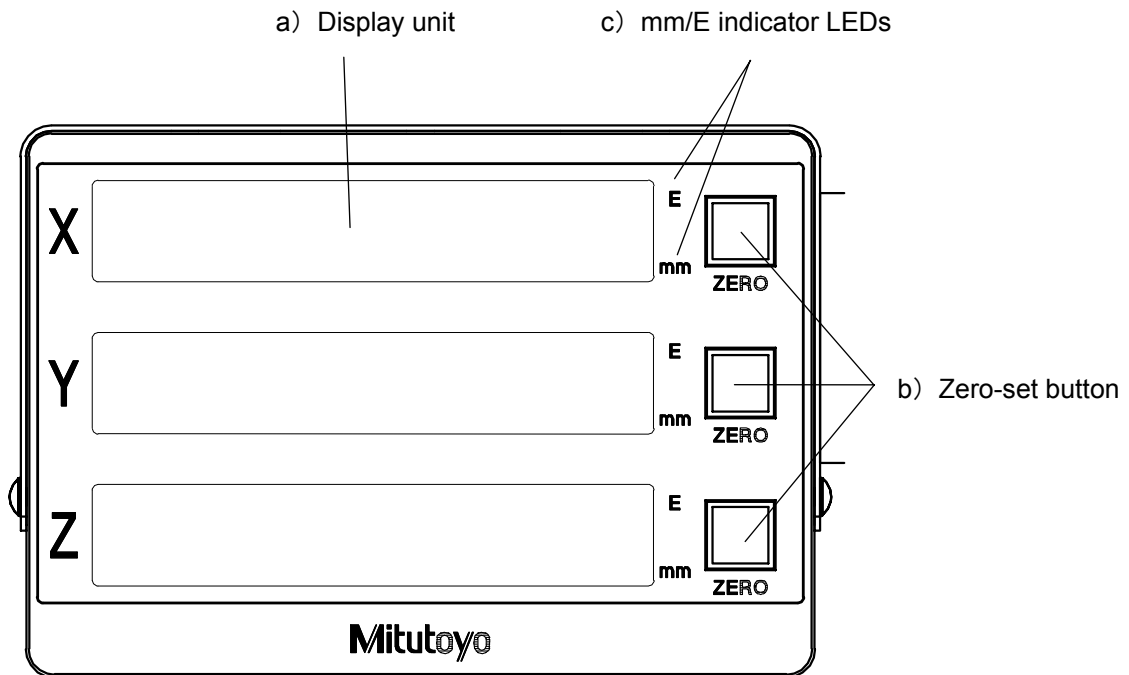

a) **Display unit**

Displays the displacement of cross-travel stage and optical tube.

Resolution: 0.001/0.0005/0.0001mm (.0001/.00005/.00001") (switchable)

b) **Zero-set button**

Zeroes the display value at any position.

Pressing the button makes the buzzer sound.

c) **mm/E or indicator LEDs**

Indicates the unit (mm or E) currently used.

A value in units of E is displayed by dividing a displacement in units of mm by 25.4.

②Rear view of the counter

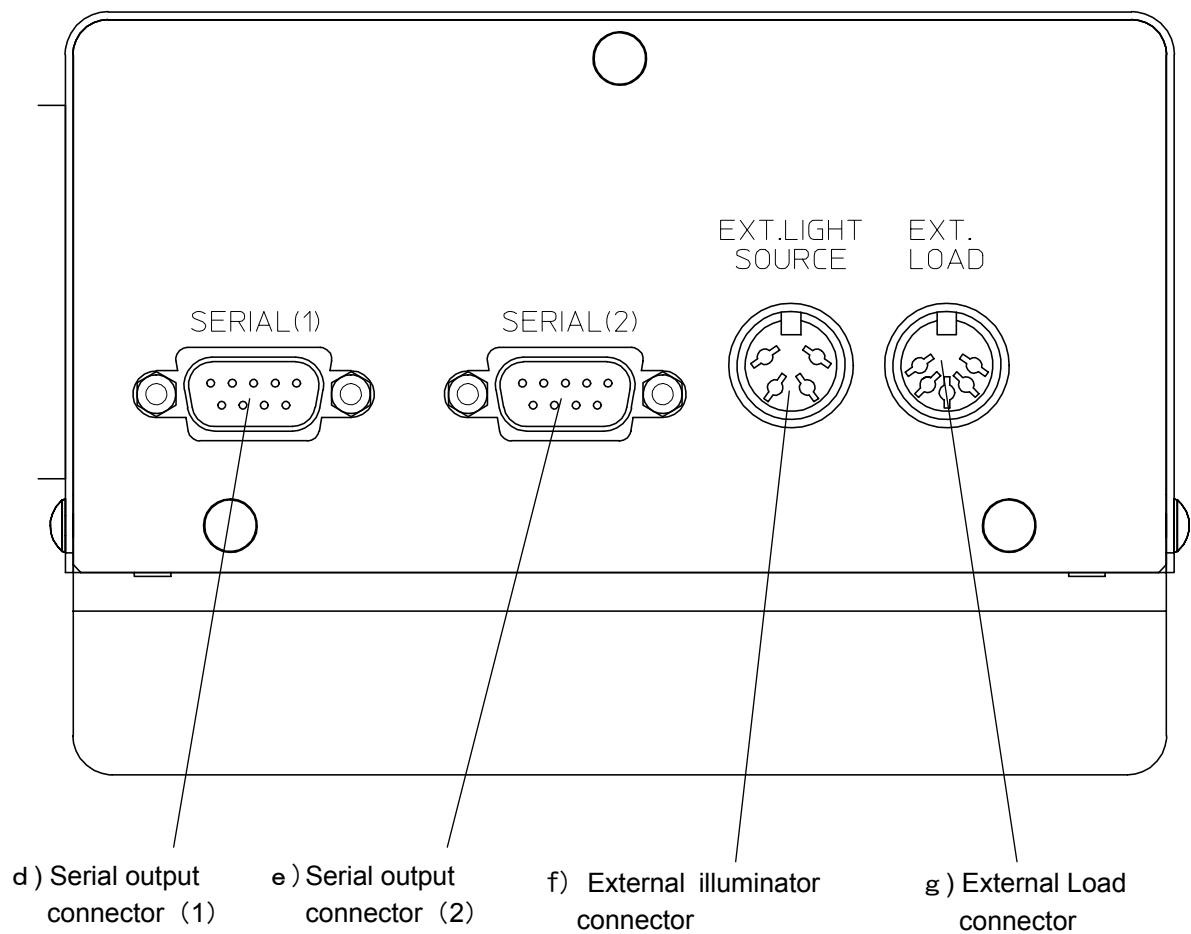

d) **Serial output connector (1)**

Connects to data processing devices such as the vision unit or QM-Data200

e) **Serial output connector (2)**

Connects to Vision unit

f) **External illumination connector**

This connector is used to connect the external light source (twin fiber illuminator) from the optional accessories.

g) **External load connector**

Connects to external load switch.

About parameters

To actually perform measurement, it is necessary to set up the count direction (count-up or count-down direction), resolution, etc. These conditions and constants are referred to as parameters. This subsection describes the function and setting procedure of each parameter.

(1) Function

Some parameters are effective for all axes and other parameters are necessary to be set for each axis. **All axes** is described for the parameters that are effective for all axes and **Individual axis** is described for the parameters to be set for each axis, respectively, in the Setting column of the following table.

No.	Parameter function	Setting
F 0 1	Display unit [mm/E (inch)] setup	All axes Each time the Y-axis zero-set button on the counter is pressed, the count unit display LED [mm] or [E] is selected (lit) alternately.
F 0 2 - 1	Count direction of X-axis (count-up or count-down direction) setup	Individual axis Each time the Y-axis zero-set button on the counter is pressed, the display of [UP] or [dn] is selected (displayed) alternately and the count direction is switched.
F 0 2 - 2	Count direction of Y-axis (count-up or count-down direction) setup	
F 0 2 - 3	Count direction of Z-axis (count-up or count-down direction) setup	
F 0 3	Resolution setup	All axes 0.1 : Minimum readout of 0.1 μ m/0.00001" 0.5 : Minimum readout of 0.5 μ m/0.00005" 1.0 : Minimum readout of 1 μ m/0.0001"
F 0 5	Setup for the number of smoothing times (Smoothing: Function to decrease the flicker of the counter by averaging detected values which is done sampling, if it is difficult to read the least significant digit due to the flicker caused by vibration of the installation site.)	All axes 1 : One time of sampling 8 : 8 times of sampling 16 : 16 times of sampling 32 : 32 times of sampling

NOTE No. F05 parameter has no function to keep measuring accuracy if vibration occurred in the microscope installation site. It is able to decrease the flicker of counter; however, the measuring accuracy of microscope fails according to the volume of vibration in the installation site.

No.	Parameter function	Setting
F 0 7 - 1	RS-232C communication condition setup [Baud rate]	1 2 0 0 b P S : 1200 bps 2 4 0 0 b P S : 2400 bps 4 8 0 0 b P S : 4800 bps 9 6 0 0 b P S : 9600 bps 1 9 2 0 0 b P S : 19200 bps
F 0 7 - 2	RS-232C communication condition setup [Data length]	7 b : 7 bits 8 b : 8 bits
F 0 7 - 3	RS-232C communication condition setup [Parity]	n o n : None E n : Even o d d : Odd
F 0 7 - 4	RS-232C communication condition setup [Stop bit]	1 b : 1 bit 2 b : 2 bits
F 0 7 - 5	RS-232C communication condition setup [Flow control (Xon/Xoff)]	o n : (Xon/Xoff) enabled O F F : (Xon/Xoff) disabled
F 0 8	Setup for the number of output axes (Sets the serial output to either two-axis of X and Y or three-axis of X, Y, and Z when the counter is three axes specification.)	2 A S : 2 axes 3 A S : 3 axes
F 0 9	RS-232C output format setup (Sets RS-232C data to the output format of Mitutoyo Vision unit or QM-Data200)	1 : Standard use 2 : Special use
F 1 0	Setup for the illumination energy saving function ※Refer to NOTICE 2 (Automatically turn off the illumination while not operating the microscope.)	0 : None 1 0 : Automatically turn off the light 10 minutes later 3 0 : Automatically turn off the light 30 minutes later
F 1 1	Setup for the volume of zero-set button (Pressing the zero-set button makes the buzzer sound.)	0 : None 1 : Volume level 1 (minimum) 2 : Volume level 2 3 : Volume level 3 4 : Volume level 4 5 : Volume level 5 (maximum)

- NOTE**
1. Use the setting "1" at No. F09 parameter. The setting "2" is the special use.
 2. Use No. F10 parameter with the setting "0". This function works only when the Vision Unit (option) is equipped. It does not work for the micrometer which is not equipped with the Vision Unit.

(2) Parameter setting procedure

Parameter starting and exiting procedure

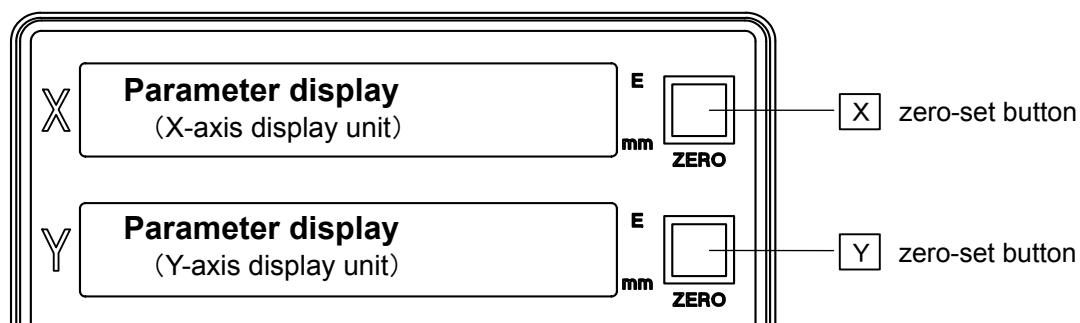

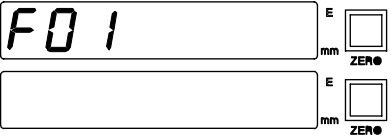
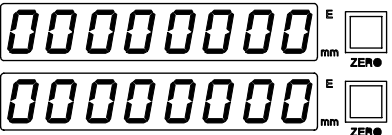
Parameter setup example	Button operation	Counter display	Operating procedure
① Starting the parameter setup mode	<input type="checkbox"/> X + <input type="checkbox"/> Y + Power switch		Turn on the power switch of microscope main unit while pressing the X-axis and Y-axis zero-set buttons at the same time..
② Switching parameters	<input type="checkbox"/> X	F 0 1 → F 0 2 - 1 → F 0 9 → F 0 1 →	Each time the X-axis zero-set button is pressed, the parameter display changes to the next in incremental order. The parameters are looped.
③ Switching parameter settings	<input type="checkbox"/> Y	0 . 1 → 0 . 5 → 1 . 0 → 0 . 1 (For a resolution)	Each time the Y-axis zero-set button is pressed, the parameter setting changes to the next. The parameter settings are looped.
④ Exiting the parameter setup mode (Loading the set content)	<input type="checkbox"/> X + <input type="checkbox"/> Y		Keep pressing the X-axis and Y-axis zero-set buttons at the same time for more than 3 seconds.

(3) Parameter setting operation examples

Parameter setup example	Button operation	Counter display	Operating procedure
Setting the display unit (Select "mm")	X Y		<ol style="list-style-type: none"> 1. Press the X-axis zero-set button to select parameter [F01]. 2. Press the Y-axis zero-set button to select [mm].
Setting the count direction (Reverse the count direction of X-axis)	X Y		<ol style="list-style-type: none"> 1. Press the X-axis zero-set button to select parameter [F02-1]. 2. Press the Y-axis zero-set button to select the setting (here [dn]) unlike the present setting (here [UP]).
Setting the count direction (Reverse the count direction of Y-axis)	X Y		<ol style="list-style-type: none"> 1. Press the X-axis zero-set button to select parameter [F02-2]. 2. Press the Y-axis zero-set button to select the setting (here [UP]) unlike the present setting (here [dn]).
Setting the count direction (Reverse the count direction of Z-axis)	X Y		<ol style="list-style-type: none"> 1. Press the X-axis zero-set button to select parameter [F02-3]. 2. Press the Y-axis zero-set button to select the setting (here [UP]) unlike the present setting (here [dn]).
Setting a resolution (Select "0.1μm")	X Y		<ol style="list-style-type: none"> 1. Press the X-axis zero-set button to select parameter [F03]. 2. Press the Y-axis zero-set button to select [0.1].

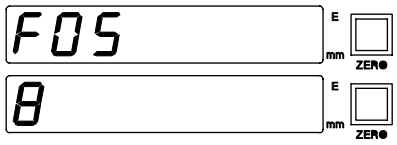
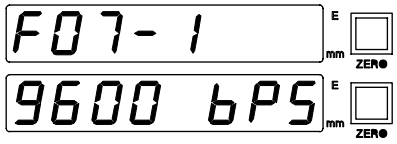
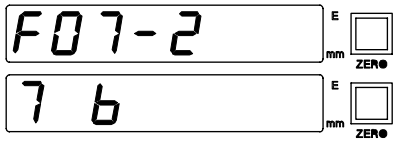
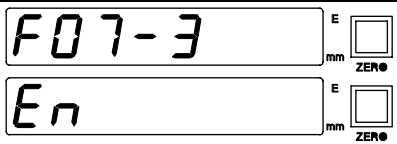
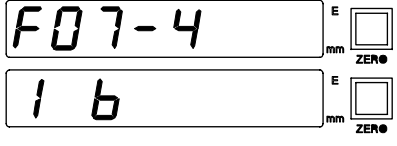
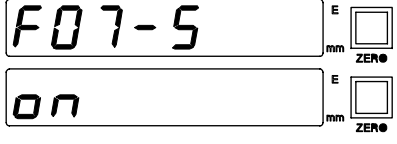
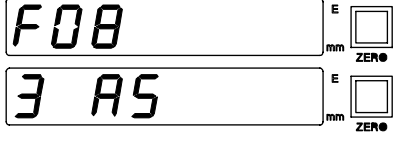
Parameter setup example	Button operation	Counter display	Operating procedure
Setting the number of smoothing times (Select 8 times of smoothing)	<input type="checkbox"/> X <input type="checkbox"/> Y		1. Press the X-axis zero-set button to select parameter [F05]. 2. Press the Y-axis zero-set button to select [8].
Setting the RS-232C Communication condition (Select a baud rate of 9600bps)	<input type="checkbox"/> X <input type="checkbox"/> Y		1. Press the X-axis zero-set button to select parameter [F07-1]. 2. Press the Y-axis zero-set button to select [9600 bPS].
Setting the RS-232C Communication condition (Select a data length of 7 bits)	<input type="checkbox"/> X <input type="checkbox"/> Y		1. Press the X-axis zero-set button to select parameter [F07-2]. 2. Press the Y-axis zero-set button to select [7 b].
Setting the RS-232C communication condition (Select the even parity)	<input type="checkbox"/> X <input type="checkbox"/> Y		1. Press the X-axis zero-set button to select parameter [F07-3]. 2. Press the Y-axis zero-set button to select [En].
Setting the RS-232C Communication condition (Select one stop bit)	<input type="checkbox"/> X <input type="checkbox"/> Y		1. Press the X-axis zero-set button to select parameter [F07-4]. 2. Press the Y-axis zero-set button to select [1 b].
Setting the RS-232C Communication condition (Select the flow control of enabled Xon/Xoff)	<input type="checkbox"/> X <input type="checkbox"/> Y		1. Press the X-axis zero-set button to select parameter [F07-5]. 2. Press the Y-axis zero-set button to select [on].
Setting the number of output axes (Select 3 axes)	<input type="checkbox"/> X <input type="checkbox"/> Y		1. Press the X-axis zero-set button to select parameter [F08]. 2. Press the Y-axis zero-set button to select [3 AS].

1.2.5 Illuminator

- 27) **LED control unit:** Controls the lighting of the LED illuminator.
- 28) **Halogen control unit:** Controls the lighting of the halogen illuminator.

① Front panel of control unit (common to LED/halogen)

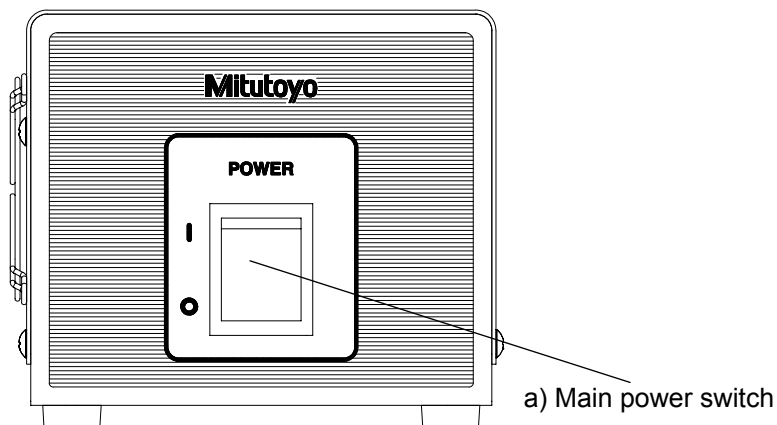

a) **Main power switch**

This switch is used to supply power to the whole system.

NOTE To shut off the power completely, turn off the main power switch.

② Rear panel of control unit
OLED control unit

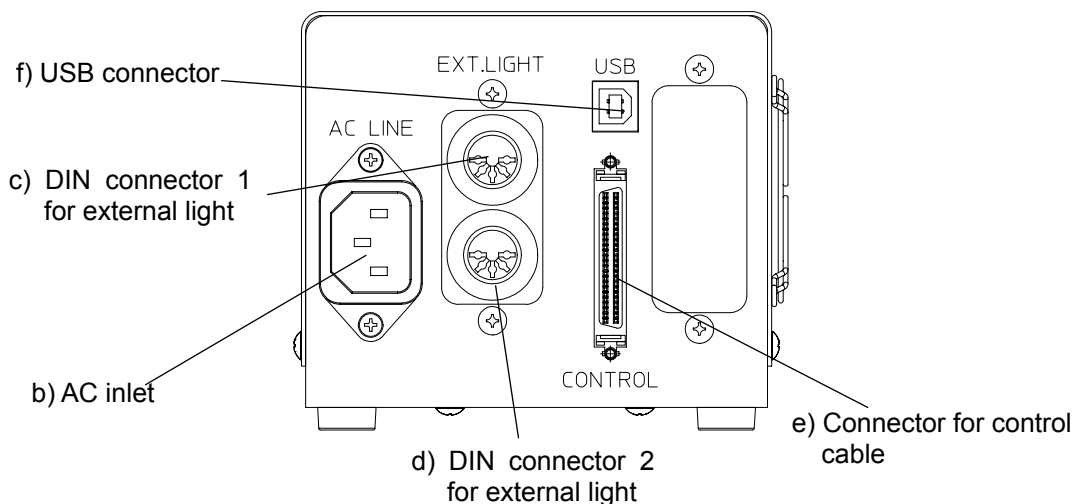

○Halogen control unit

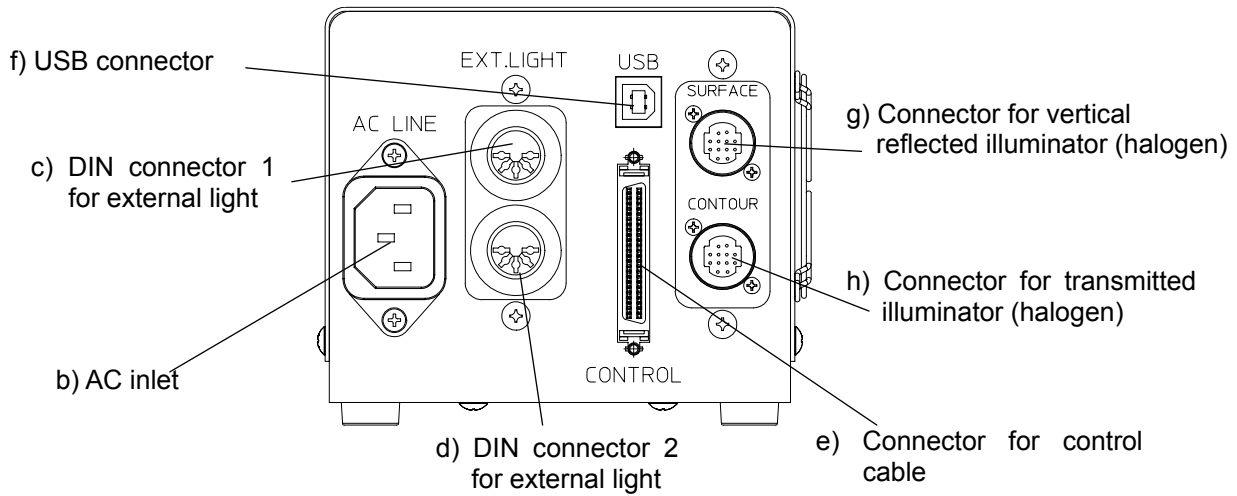

b) AC inlet

Connect the power cord.

c) DIN connector 1 for external light

This connector is not used.

d) DIN connector 2 for external light

This connector is used to connect a fiber light source for vertical reflected illuminator.

e) Connector for control cable

This connector is used to connect this unit and the cable connected to the control unit.

f) USB connector

This connector is not used.

g) Connector for vertical reflected illuminator (halogen)

This connector is not used.

h) Connector for transmitted illuminator (halogen)

This connector is used to connect a halogen type transmitted illuminator.

2

Installation and Setup

This chapter describes the installation environments and connection method of the MF-U series Measuring Microscope.

2.1 Installation

Although the weight varies depending on the model, this machine is quite heavy (approx. 65.5~140kg). Mitutoyo handles and sets up the machine, because it is necessary to confirm and adjust the accuracy after installation.

NOTE On the Reinstallation.....The microscope main unit reinstallation performed on the client's own may deteriorate the required accuracy due to vibrations and shocks during transportation. Therefore, it is recommended that the main unit be reinstalled by Mitutoyo. If the system is desired to be reinstalled, be sure to contact the Mitutoyo sales office.

2.2 Remove the Fixing Plate

Remove the fixing plates for cross-travel stage and optical tube unit after installing the main unit.

2.2.1 Removing the fixing plate for cross-travel stage

Remove eight pieces of fixing plate (one piece for MF-U * 505C, MF-U * 1010C and MF-U * 2010C from the XY stage. (Use a 3mm Allen wrench).

- ① For MF-U * 2017C, MF-U * 3017C, and MF-U * 4020C

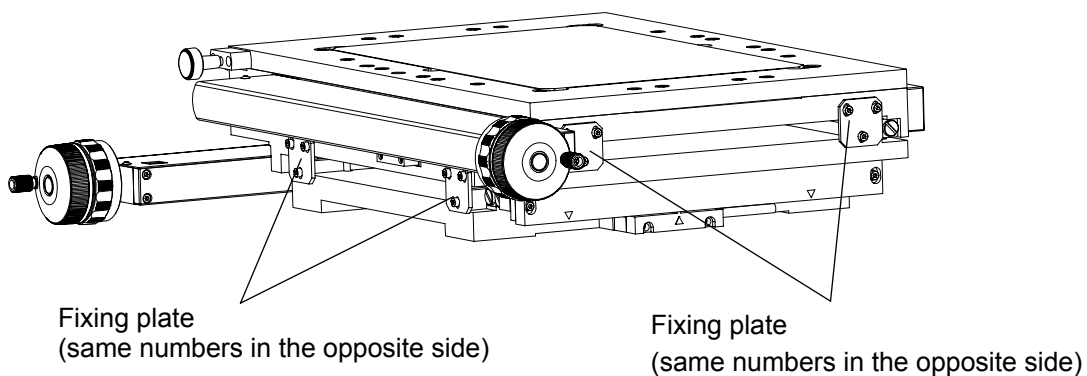

- ② For MF-U * 505C, MF-U * 1010C, and MF-U * 2010C

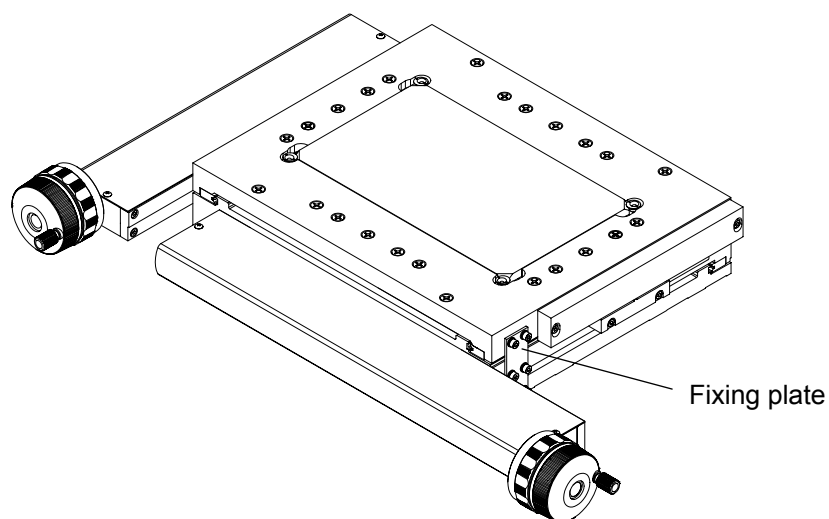

2.2.2 Removing the fixing plate for optical tube unit

Remove a fixing plate from the optical tube unit. (Use a 3mm Allen wrench.)

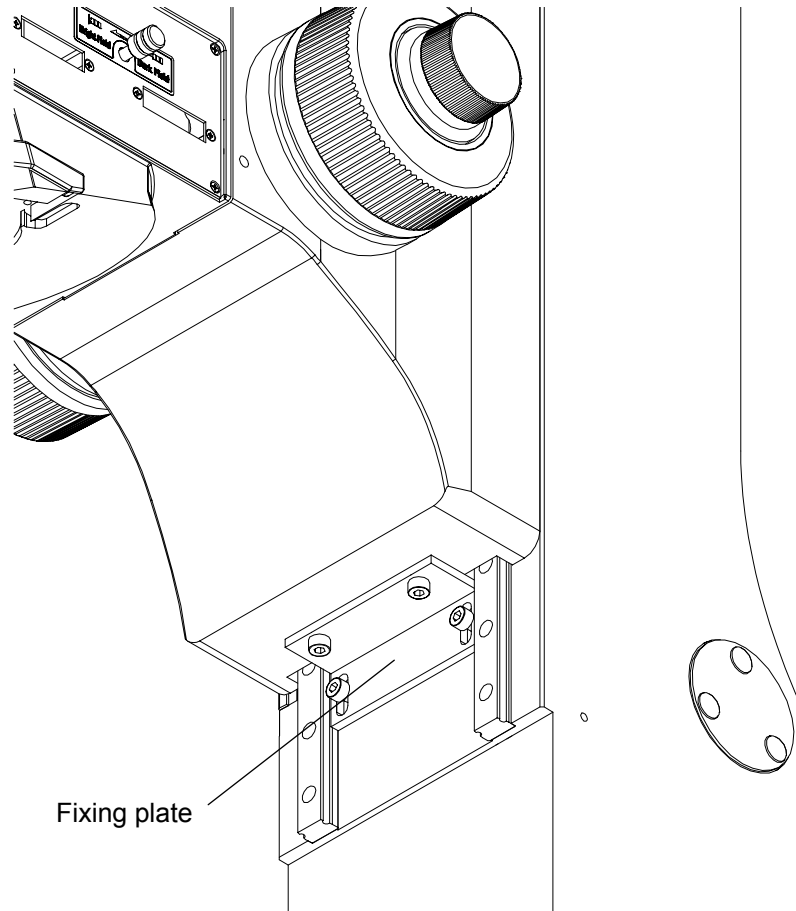

2.3 Moving the Table on the Cross-Travel Stage

Check the operation of the table and optical tube unit (see the next section) according to the following procedure. Moving the table and optical tube unit is the basic operation for performing measurement. Sufficiently understand the operation of these units and familiarize yourself with it.

2.3.1 When a great and quick travel of the table is required

This operation is required to roughly position a workpiece or quickly escape it.

- ① Turn the coarse-feed wheel clockwise when viewed from the fine-feed wheel side to unlock the table.
- ② Hold the coarse-feed wheel until the table moves to the required position.
- ③ Turn the wheel counterclockwise to lock the table.

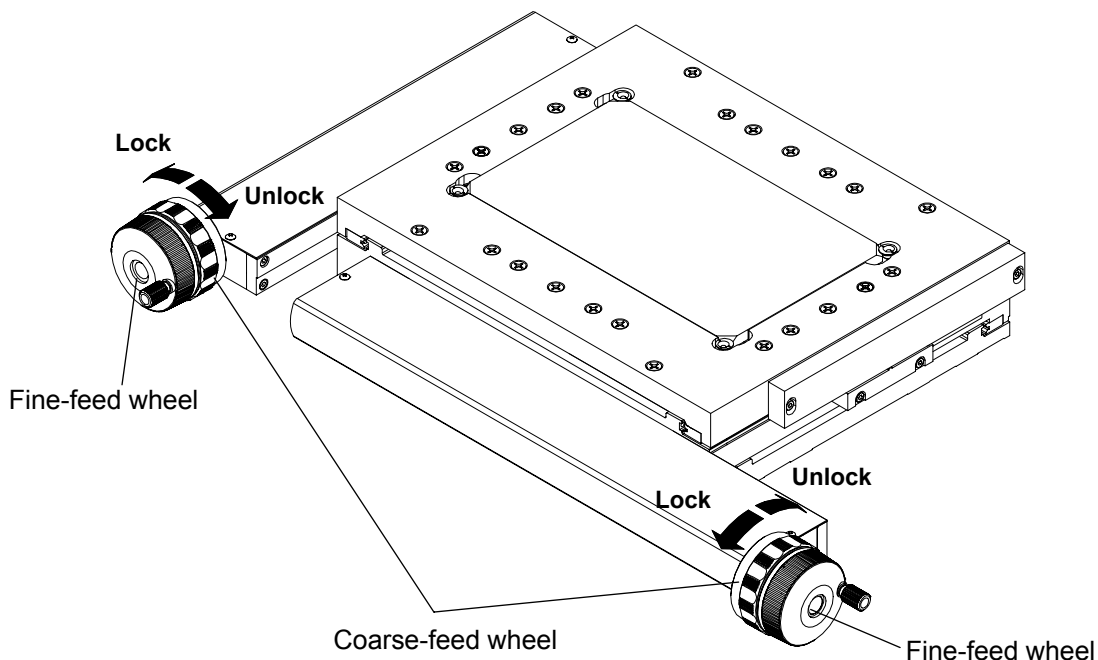

IMPORTANT When moving the table, do not make the impact on the stopper of stroke end. If the stroke end stopper is hit, the accuracy may decrease.

2.3.2 When a fine travel of the table is required

Turn the fine-feed wheel until the table moves to the required position. The table moves 1mm per full rotation of the wheel.

This operation is necessary for final positioning of a workpiece.

IMPORTANT When reached the stroke end, do not turn the fine-feed wheel any more. Turning the wheel by force may prevent the smooth operation.

2.4 Moving the Optical Tube Unit

2.4.1 When a great and quick travel of the unit is required

Turn the coarse-feed wheel with a large diameter until the optical tube unit moves to the required height. The unit moves 10mm per full rotation of the wheel. This operation is required to roughly focus the optical tube or quickly escape it.

2.4.2 When a fine travel of the unit is required

Turn the fine-feed wheel with a small diameter until the optical tube unit moves to the required height. The unit moves 0.1mm per full rotation of the wheel. This operation is necessary for final focusing of the optical tube.

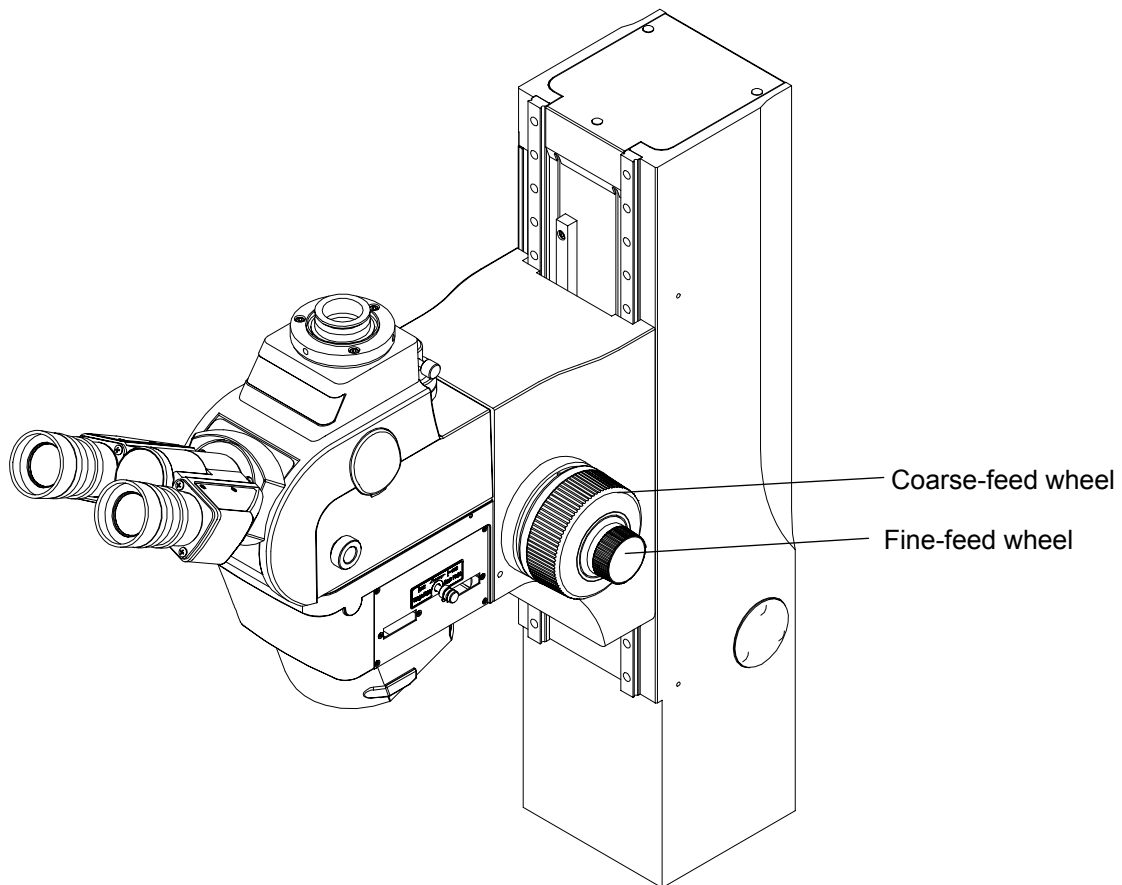

- NOTE**
1. Exercise sufficient care when the optical tube unit descends so as not to hit a workpiece by lens or the optical tube unit.
 2. Do not turn both coarse-feed wheels simultaneously in the reverse direction.
 3. Do not turn the wheels any more when the tube unit has reached either stroke end.

There is a risk of damage to the internal feed mechanism in either case of above-mentioned 2 and 3.

2.5 Leveling the Main Unit

To level the main unit, perform the following procedure.

- ① Place the main unit on the dedicated table.

TIP Use a mounting stand (No.176-309) or a rigid stable stand.

If any annoying image waving is caused under high-magnification observation, use the vibration isolating stand (No.176-308).

- ② Turn five leveling screws (two pieces on both sides of the front bottom, two pieces on both sides of the rear bottom, one piece on rear center) to the direction that they are tightened up using a screwdriver, etc. Especially tighten the two pieces on both sides of the rear bottom almost fully so that they may not interfere with the installation surface.
- ③ Place a level on the stage glass to level the main unit by three leveling screws (front two pieces, rear center one piece).
- ④ After leveling, turn the right and left screws of rear side until they touch the dedicated table slightly.

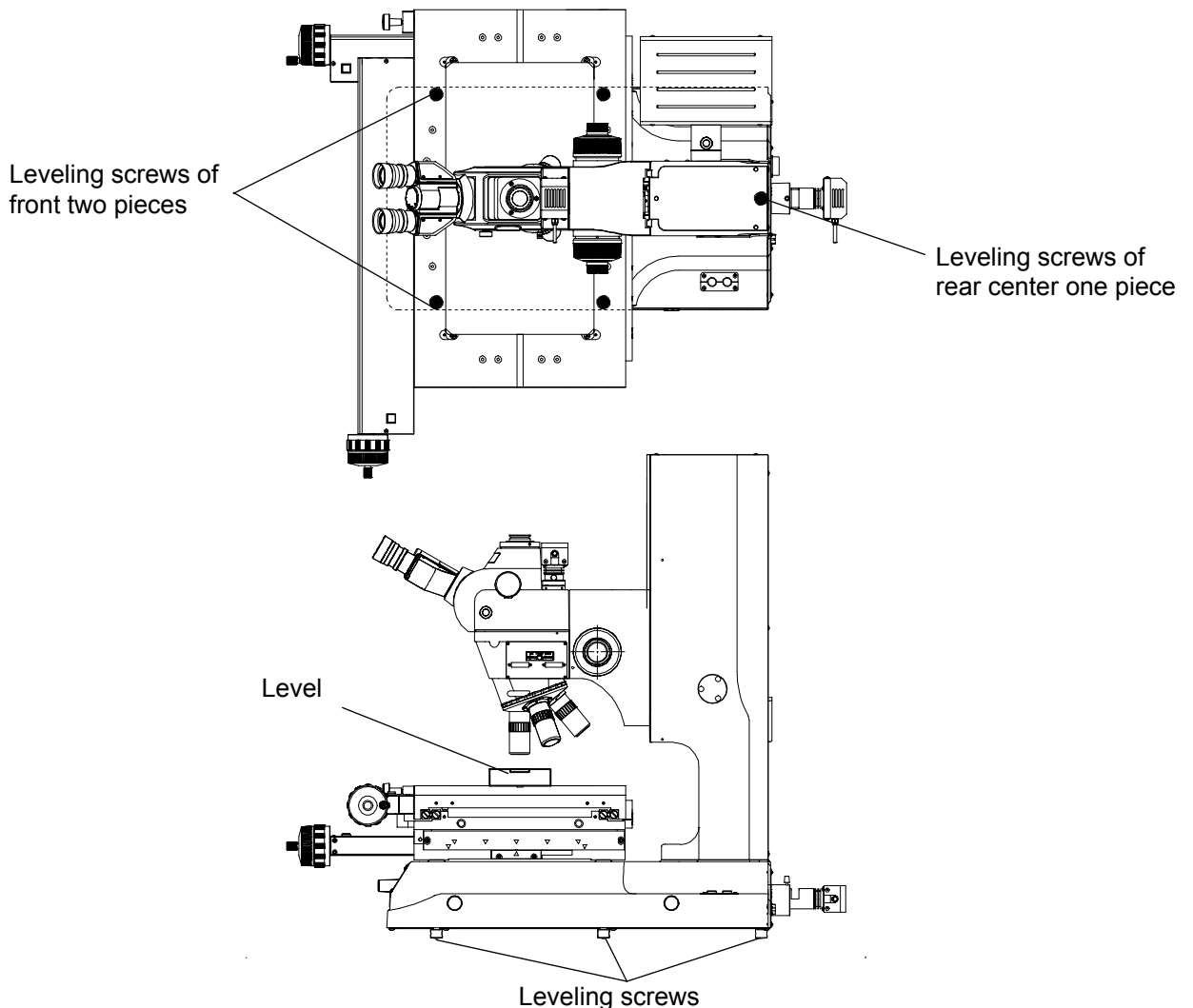

2.6 Attaching a Revolver

Attach the optional revolver to the optical tube unit according to the following procedure.

- ① While securely holding the revolver, fit the two pins into the holes of optical tube unit, and then push the revolver upward.
- ② Insert the Allen wrench (nominal 1.5mm) into the holes of both sides of optical tube unit to tighten the revolver setscrews (2 pieces) that secure the revolver firmly while holding the revolver.

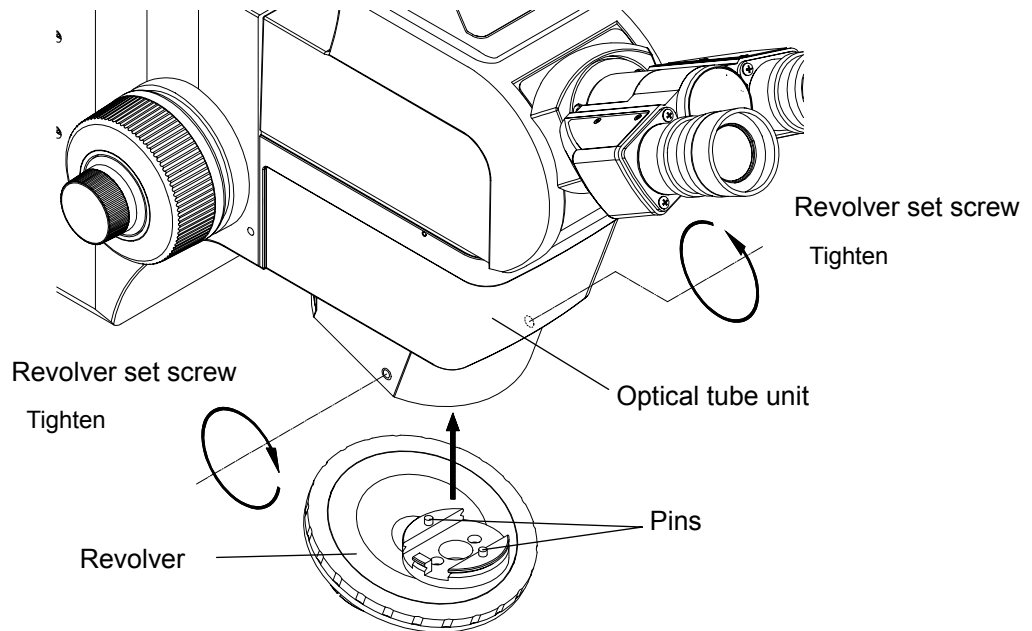

Caution

1. There is a risk that the revolver drops when switching and mounting/dismounting an objective, etc., if the revolver is not securely fixed. Mount the revolver correctly to the optical tube unit and fix it with the screws securely so that the clearance becomes as shown in the figure below:

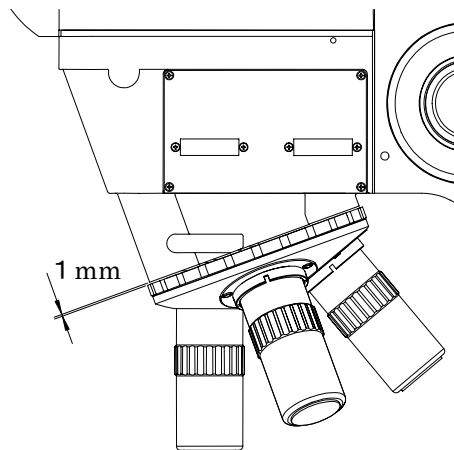

2. Be sure to keep holding the revolver and loosen the revolver set screws when dismantling the revolver.

If not, the revolver may drop, possibly damaging the instrument or a workpiece.

2.7 Mounting the Lenses

Mount the objective and eyepieces according to the following procedure:

2.7.1 Mounting the objective

- ① Turn the coarse/fine focusing wheel to move the optical tube unit to a position where the objective can be easily mounted.
- ② Turn the objective clockwise (as viewed from the bottom) to fix it to the revolver.

NOTE If the revolver with the field centering mechanism is mounted, use the highest-magnification objective of those to be used in the reference hole without the field centering mechanism.

2.7.2 Mounting the eyepieces

Remove the cap from the eyepiece mount to mount the eyepieces.

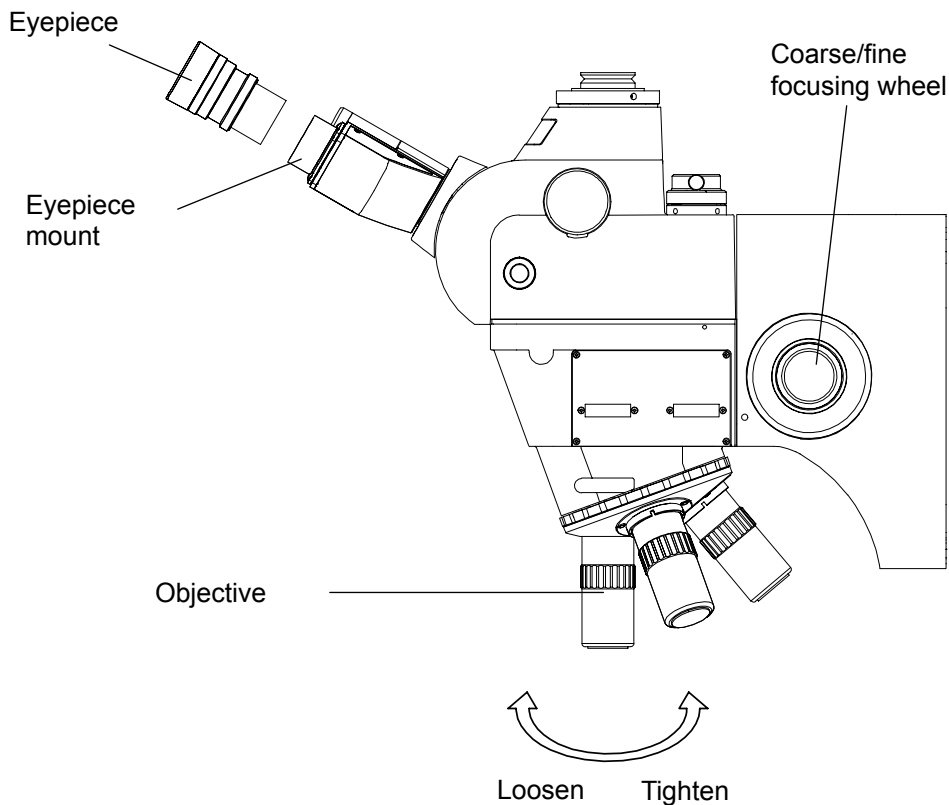

-
- IMPORTANT**
1. Do not touch the lens surface with fingers.
 2. Be careful not to drop the lens.
-

2.8 Installation of the Illuminators

Insert a transmitted illuminator and a vertical reflected illuminator into their respective mounts in the main unit to fix them with clamp screws according to the following figure. Set the cables so as not to touch the illuminators.

2.8.1 Transmitted illuminator

2.8.1.1 For LED illuminator

- ① Mount the illuminator to the frame of the rear connector panel, and secure the illuminator with a clamp screw.
- ② Connect the cable plug to the connector for transmitted illuminator.

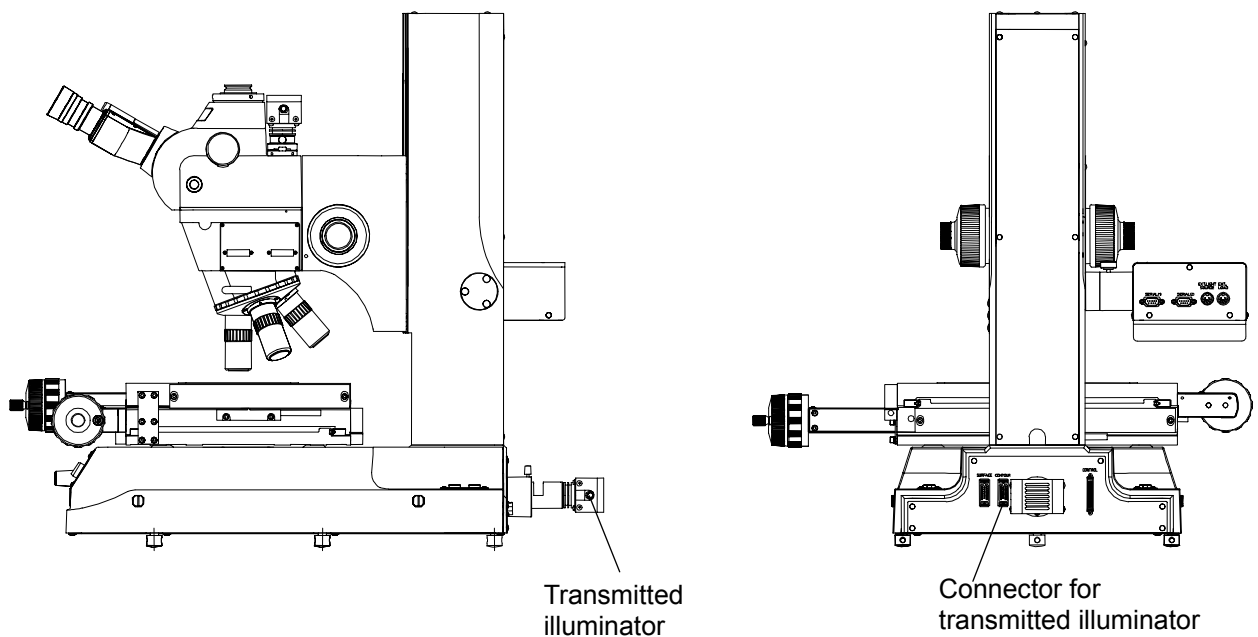

-
- IMPORTANT**
1. Do not turn on the light when the transmitted illuminator and vertical reflected illuminator are removed from the main unit. After turning on the illuminator, it becomes very hot. Do not illuminate upward, otherwise the cable will be deformed by the heat.
 2. Do not place anything on the illuminator and its peripheral part. The efficiency of the air-cooling fan decreases and a trouble will result.
-

2.8.1.2 For halogen illuminator

- ① Mount the illuminator to the frame of the rear connector panel, and secure the illuminator with a clamp screw.
- ② Connect the cable plug to the connector for transmitted illuminator.

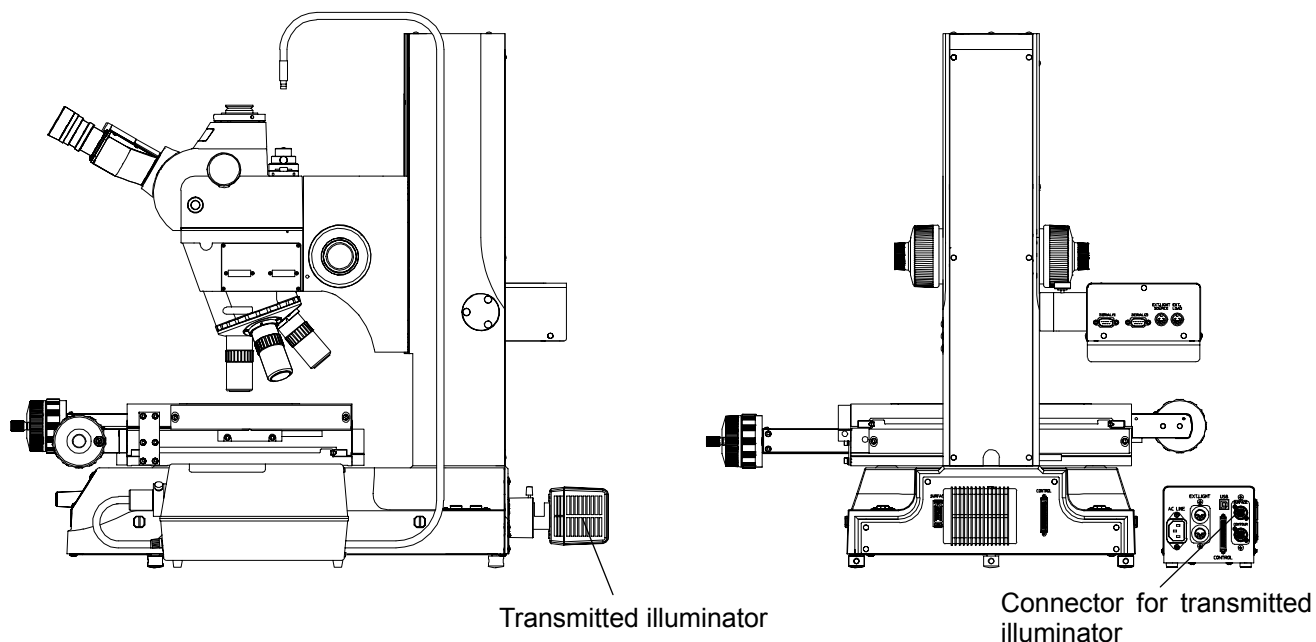

-
- IMPORTANT**
1. Remove the transmitted illuminator not to turn on the light. The illuminator becomes remarkably hot when it lights. If the illuminator is directed upward and lighted, the cable and other materials may be deformed by heat.
 2. Do not place anything on the illuminator and its periphery. Failure to observe this may decrease the efficiency of the cooling fan resulting in trouble.
-

2.8.2 Reflected illuminator

2.8.2.1 For LED illuminator

- ① Insert the illuminator into the vertical reflected illumination inlet of the aperture diaphragm and secure the illuminator with a clamp screw.
- ② Connect the cable plug to the connector for vertical reflected illuminator.

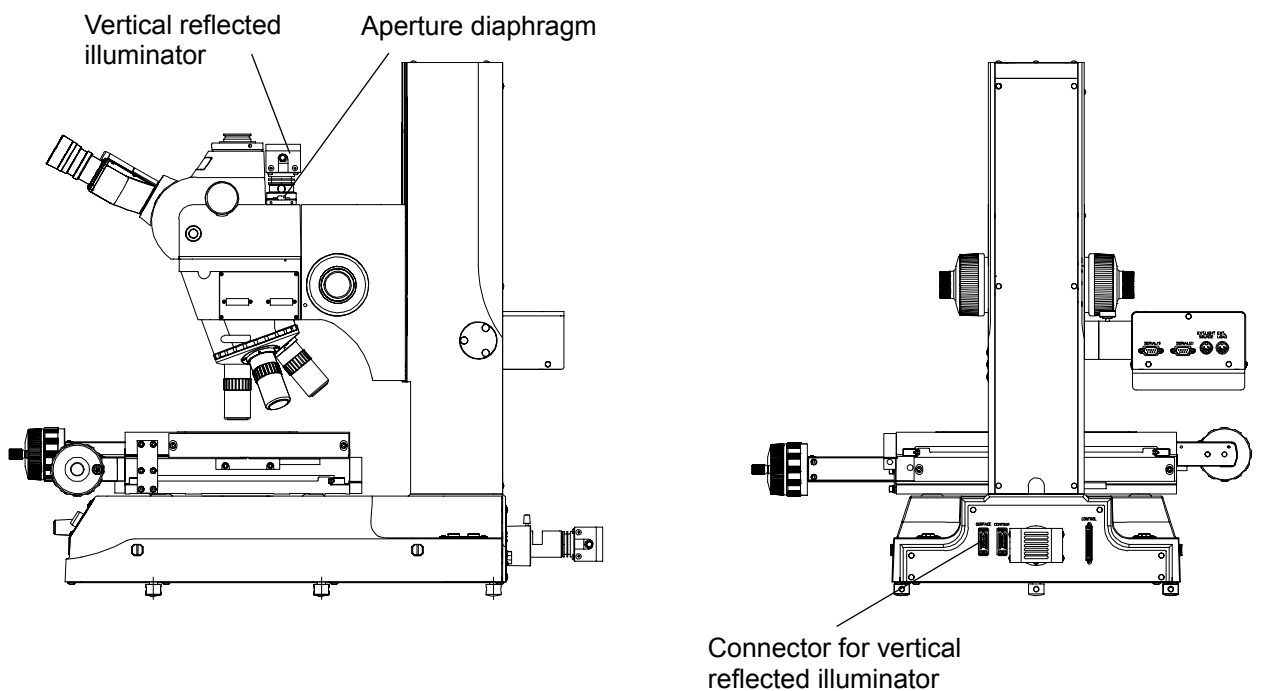

-
- IMPORTANT**
1. Remove the transmitted illuminator not to turn on the light. The illuminator becomes remarkably hot when it lights. If the illuminator is directed upward and lighted, the cable and other materials may be deformed by heat.
 2. Do not place anything on the illuminator and its periphery. Failure to observe this may decrease the efficiency of the cooling fan resulting in trouble.
-

2.8.2.2 For halogen illuminator

- ① Insert the supplied fiber collar into the vertical reflected illumination inlet of the aperture diaphragm and secure the collar with a clamp screw.
- ② Insert the fiber into the fiber collar inlet and secure the fiber with a clamp screw.

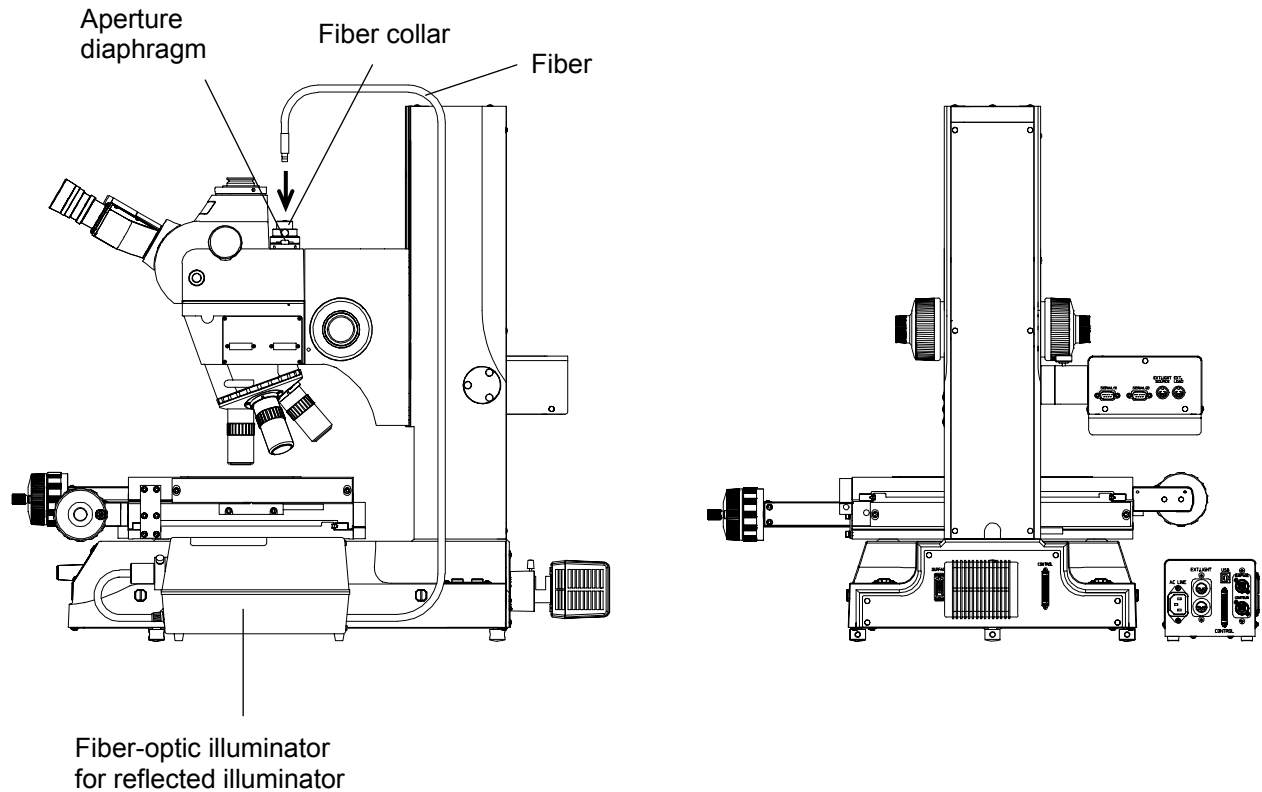

-
- IMPORTANT**
1. Remove the transmitted illuminator not to turn on the light. The illuminator becomes remarkably hot when it lights. If the illuminator is directed upward and lighted, the cable and other materials may be deformed by heat.
 2. Do not place anything on the illuminator and its periphery. Failure to observe this may decrease the efficiency of the cooling fan resulting in trouble.
-

- TIP**
1. Fiber-optic illuminator for reflected illumination is an optional accessory. Select 100 W of fiber-optic illuminator (No. 176-315) or 150 W of fiber-optic illuminator (No. 176-316) is according its use.
 2. Use of the external light source control cable allows 150 W/100 W of fiber-optic illuminator to be controlled with the volume on the front panel of the microscope. (Connect the cable to "DIN connector 2" of the control unit.)
-

2.9 Changing the Counter Mounting Angle and Position

This measuring microscope is packed with the counter mounted on the left side of the column as shown in the figure in "1.2 Name and Function of Each Part".

The counter rotates vertically in order to remove the adverse condition such that the counter display is difficult to view or the keys are not easy to operate. Loosen the clamp screw on the flange located between the counter and the column, rotate the counter to a desired angle, and then tighten the clamp screw.

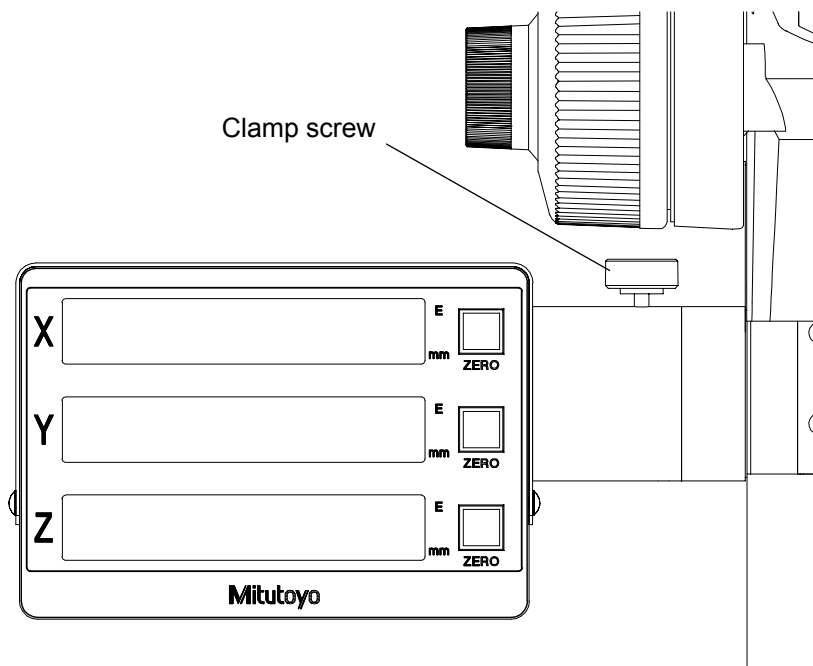

Also, the counter of this microscope is able to be mounted on the right side of the column to meet the client's needs for operability. If the client needs to change the counter mounting position to the right side of the column, contact the nearest Mitutoyo sales office.

2.10 Connecting Each Part

Connect the cables of each part according to the following figure.

① Microscope main unit

- ① Connect the microscope main unit and control unit with the control cable.
- ② Plug the power cord into the control unit, then plug the power plug into the power outlet.

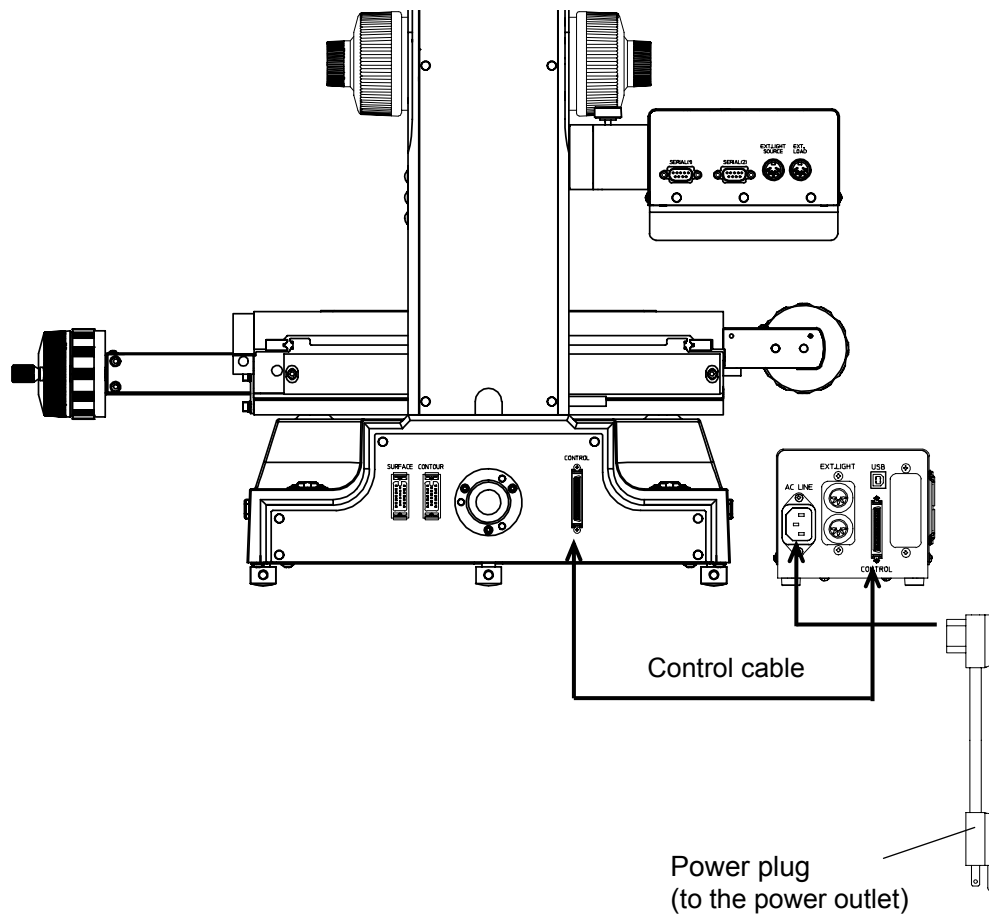

② 100 W fiber-optic illuminator

- ① Turn the unit over as shown below to confirm that the setup of VOLTAGE SELECTOR agrees with the source voltage. Switch the selector, if not.

IMPORTANT The VOLTAGE SELECTOR is set at either 100 V-system (100 to 120V) or 200 V-system (200 to 240V). On the factory shipment, it is set at the rated voltage of microscope main unit.

- ② Connect the socket of power cord with the power socket of the unit, then insert the power plug to the power supply plug socket.

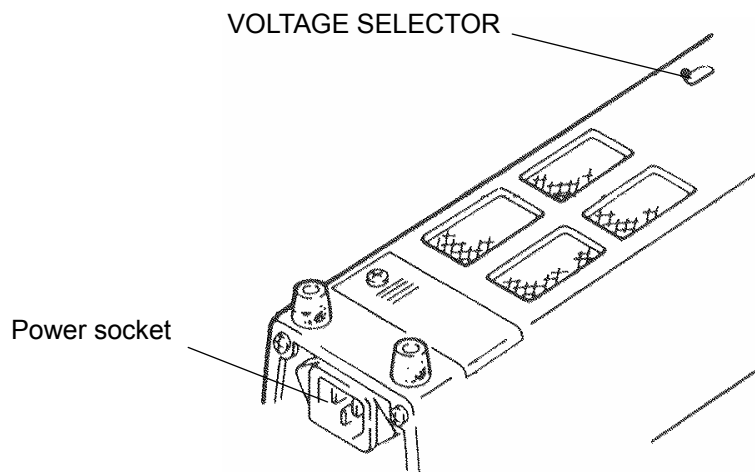

TIP Connection of “external light source control cable (for 100 W light source)” from the optional accessories to “DIN connector 2” of the control unit allows light to be controlled with the volume on the control panel.

③ 150 W fiber-optic illuminator

- ① Connect the socket of power cord to the power socket of the unit, then insert the power plug in the power outlet.

IMPORTANT 150W illuminator is applicable to 100~120V and 200~240V without switching.

TIP Connection of “external light source control cable (for 150 W light source)” from the optional accessories to “DIN connector 2” of the control unit allows light to be controlled with the volume on the control panel.

MEMO

3

Measurement Setup

This chapter explains the setup for measurement including the optical system installation and workpiece set-up.

3.1 Connection Check

Check that all connecting cables have been connected properly and as specified.

3.2 Turning the Power Supply On

Turn the power supply on according to the following procedure:

- ① Before turning the power switch on, turn the transmitted illumination knob on the control panel fully counterclockwise to minimize the light intensity.
- ② Turn on the power switch of control unit. (Switch to “ I ” position)
- ③ Turn the transmitted illumination knob clockwise to confirm that the illuminator lights up.
- ④ Turn the transmitted and vertical reflected illumination knobs clockwise to confirm that both illuminators light up.

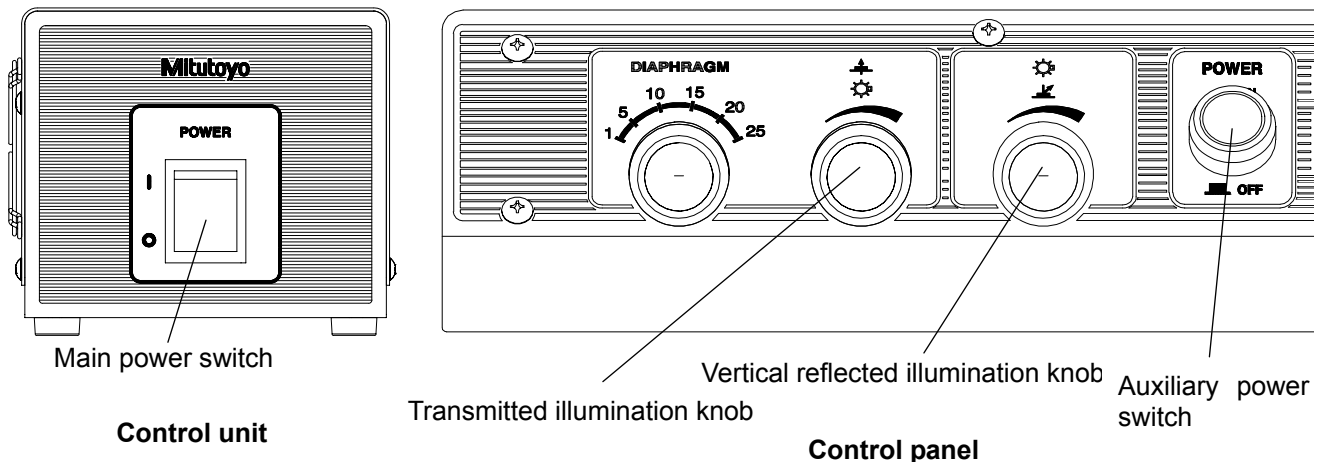

IMPORTANT

The counter may display error messages (E51, E52, E53) due to the procedure for turning ON/OFF the power supply of the microscope main unit and the peripheral equipment such as PC in the connection with some peripheral equipment when the peripheral equipment is being connected with the counter unit at RS232C.

Be sure to perform at the following order when turning the power switch ON/OFF

- For ON Peripheral equipment → Microscope main unit
- For OFF Microscope main unit → Peripheral equipment

3.3 Confirming the Filament Position of the Transmitted Illuminator (only for halogen illuminator)

When “176-348 Halogen illuminator” is selected, the filament position of the transmitted illuminator needs to be confirmed. Follow the procedure below to perform confirmation.

No centering a bulb is needed after replacing it. Confirm that the bulb is installed to the socket correctly.

(For information about replacing the bulb, refer to 4.3.1 “Replacing halogen bulbs”)

3.3.1 Confirming the position of the filament for Transmitted illuminator

- ① Mount a low-magnification objective.
- ② Turn the light on by turning the transmitted illumination knob.
- ③ Open fully the aperture diaphragm for transmitted illumination.
- ④ Remove the eyepiece to look into the objective from the optical tube.
- ⑤ Confirm that the illumination projected on the objective is circle.
- ⑥ If the illuminated circle is not round or uniform intensity, the bulb is not installed correctly. Turn the power switch off, and insert the bulb all the way until it reaches the end of the socket after the bulb becomes cool.

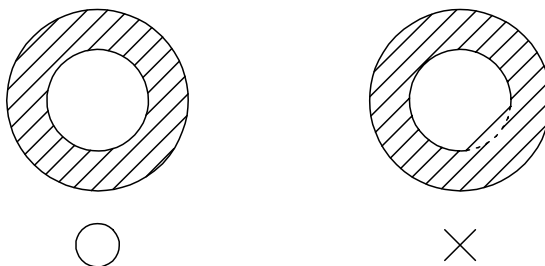

CAUTION

Right after the light is turned off, the bulb and its peripheral part are very hot. When cool enough to handle, replace the bulb carefully. (Wait for about 30 minutes as a guide.)

3.4 Adjusting the Aperture for Transmitted Illumination

The aperture diaphragm for transmitted illumination is used to adjust the Numerical Aperture (N.A) of transmitted illumination system. It controls the resolution, contrast, and depth of focus of the optical system.

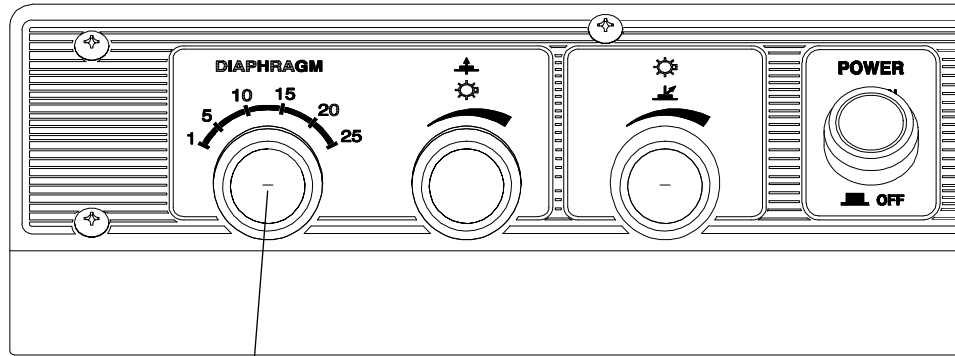

Aperture diaphragm knob for transmitted illumination

The diaphragm blades can be seen by removing the eyepiece and looking into the optical tube using an appropriate light intensity. Adjust the required aperture.

Aperture setting for obtaining a good contrast and image clarity for ordinary applications:

70 to 80% of radius

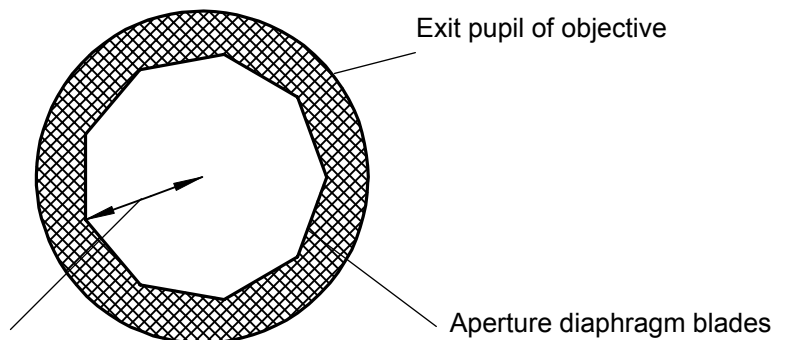

NOTE Do not set the aperture diaphragm less than 60% of the radius except for special types of workpieces, as it reduces the resolution. To avoid diffraction, the aperture diaphragm should be set to 15 or larger.

When measuring cylindrical workpieces or screw threads, the numerical aperture affects measurement accuracy. The optical aperture is given by the following formulas.

(1) **For cylindrical measurement**

$$\begin{aligned} \text{Aperture } D &= 0.18F \sqrt[3]{\frac{1}{d}} \quad F ; \text{ Focal distance of condenser lens (mm)} \\ &= 19.224 \sqrt[3]{\frac{1}{d}} \end{aligned}$$

(2) **For screw thread measurement**

$$\text{Aperture } D = 19.224 \sqrt[3]{\frac{\sin \frac{\alpha}{2}}{d_2}}$$

D : Corresponds to the aperture setting 1 to 25 indicated on the aperture diaphragm knob on the control panel of the measuring unit.

d : Workpiece diameter

d₂ : Pitch diameter of screw thread

α : Screw thread angle

The following graph shows the correlation between the workpiece diameter d and the optimal aperture setting D. Adjust the aperture diaphragm knob to the optimal position by referring to this graph.

Aperture D(mm)

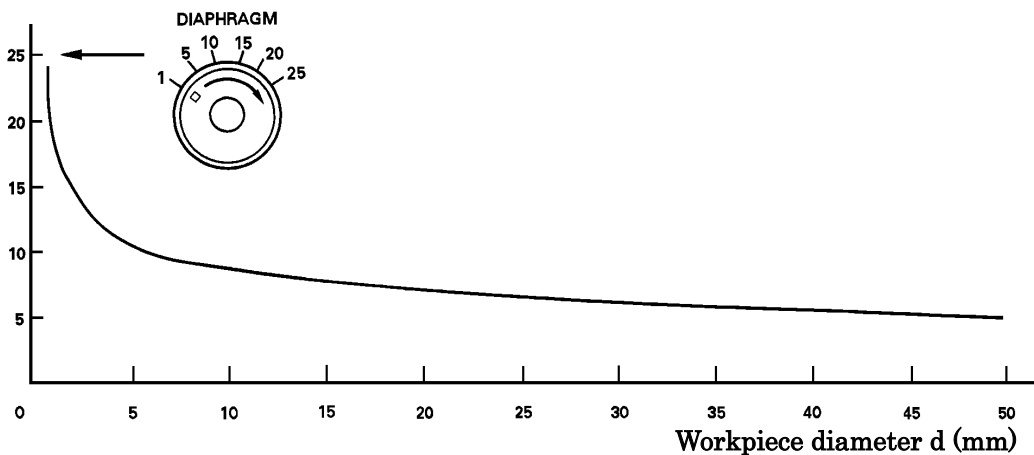

3.5 Adjusting the Aperture for Reflected Illumination

3.5.1 Adjusting the aperture diaphragm for the illumination

The aperture diaphragm for vertical reflected illumination is used to adjust the Numerical Aperture (N.A) of vertical reflected illumination system. It controls the resolution, contrast, and depth of focus of the optical system.

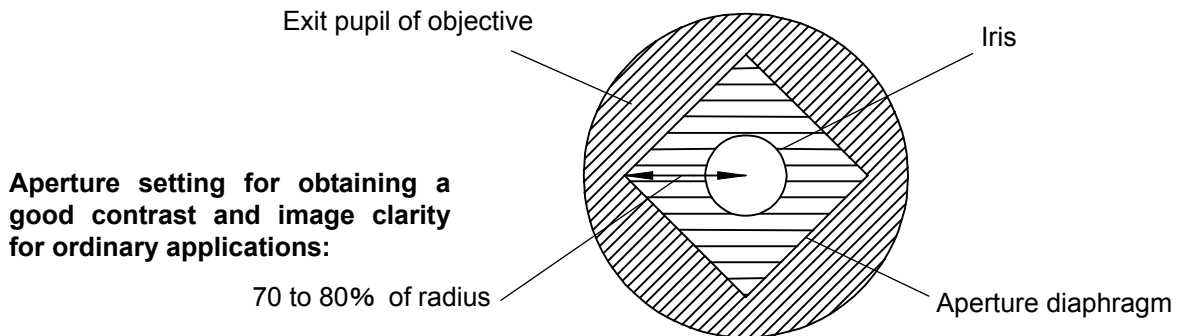

Confirm that the exit pupil of the objective as above can be seen by removing the eyepiece and looking into the optical tube with an appropriate light intensity. Slide the lever of aperture diaphragm to adjust so that the optimum numerical aperture is obtained.

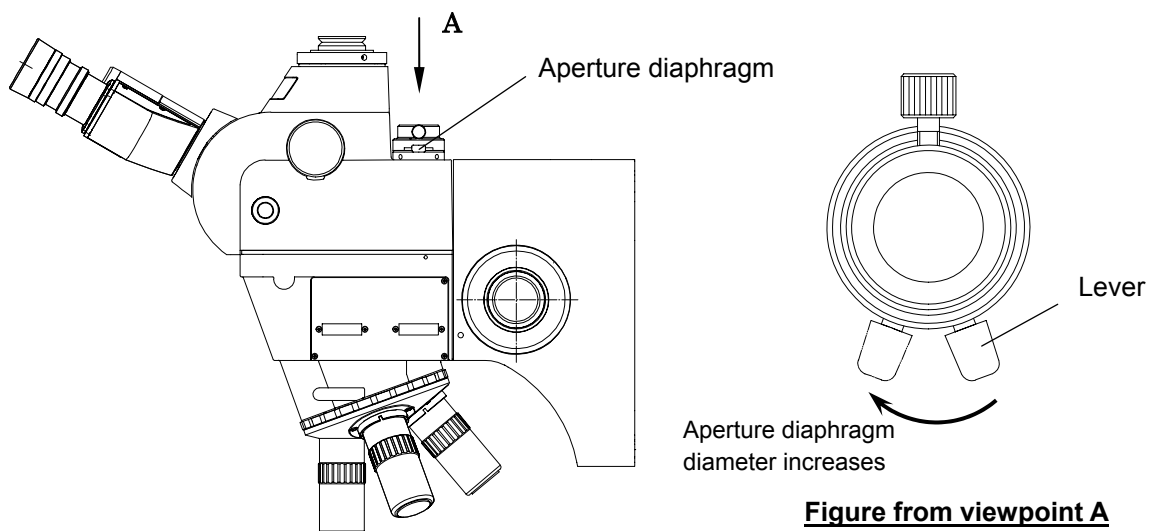

NOTE Do not set the aperture diaphragm less than 60% of the exit pupil radius except for special types of workpieces. This will reduce the resolution.

3.5.2 Centering the aperture diaphragm

The center of the aperture diaphragm has been aligned with the axis of illumination beam or the center of the field of view at the factory. If the aperture diaphragm is off-center, re-adjust it according to the following procedure:

- ① Pull off one of the eyepieces to look into the optical tube.
- ② Turn the aperture diaphragm lever all the way rearward to minimize the diameter of the diaphragm.

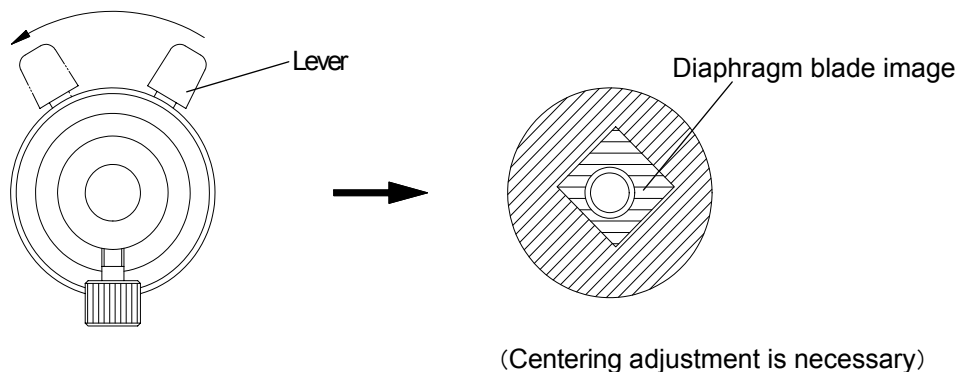

- ③ Turn the adjustment screws (2 pieces) to move the aperture diaphragm image to the center of optical tube.
(The leaf spring housed inside of the aperture diaphragm enables adjustment with 2 screws.)
- ④ Return the aperture diaphragm lever to the optimal position.

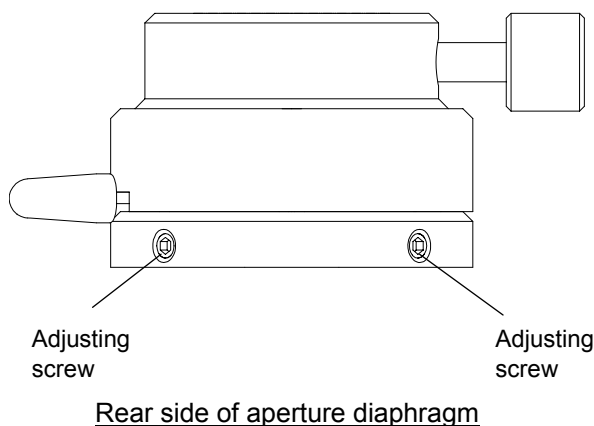

TIP The aperture diaphragm function is valid for objectives with magnifications of 20X or less. Objectives with magnifications of 50X or more have the effect of reducing the flare on an observation image

3.6 Aligning the Visual Field Center

Aligning is performed to position objectives so as not to deviate the visual field center when an objective is switched. (Performs only when the revolver with aligning mechanism is selected.) Refer to each user's manual of revolver with aligning mechanism to adjust it.

3.7 Replacing the Objective

To replace the objective, observe the following procedure.

- ① Turn the coarse/fine focusing wheel of measuring microscope to move the optical tube unit to a position where the objective can be easily replaced.
- ② Turn the objective counterclockwise (as viewed from the bottom), then remove it from the revolver.
- ③ Mount the objective to use on the revolver. (To mount the objective, turn it clockwise, as viewed from the bottom.)

-
- NOTE**
1. **Do not touch the objective lens surface with your fingers.**
 2. **Be careful not to drop the lens.**
 3. **When tightening the replacement objective, do not apply excessive force.**
 4. **Store the removed objective in the supplied lens case.**
-

3.8 Setting Up a Workpiece

Place a workpiece as its surface to be measured (on the objective side) become at right angles to the optical axis of objective. The stage glass surface is at right angles to the optical axis of objective. If the workpiece surfaces are parallel, place the workpiece directly on the stage glass. If the surfaces are not parallel, adjust the measured surface to become at right angles to the optical axis with an appropriate fixture. Unless the measured surface is at right angles to the optical axis, it is impossible to focus the objective over the entire field of view.

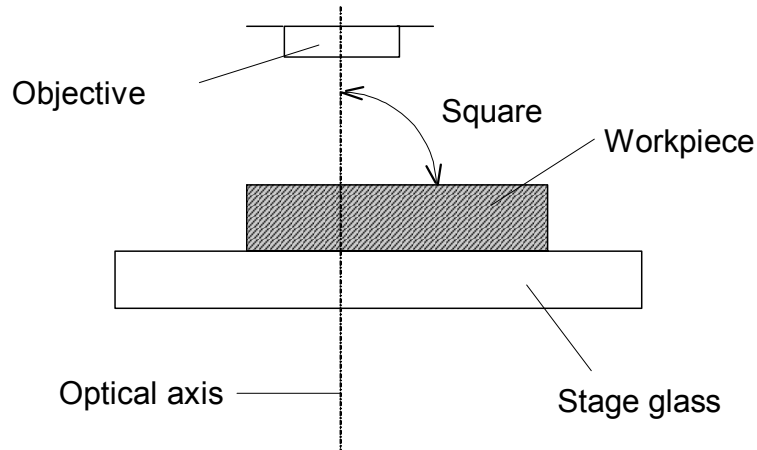

-
- NOTE**
1. A shock while setting up a workpiece may break the stage glass, resulting in damage and personal injury. Exercise care so as not to bump the measuring unit during setup.
 2. A workpiece that extends over the end of the XY stage can interfere with the main unit when the stage moves. Carefully mount the fixture on the stage.
 3. If a large size of cross-travel stage such as MF-U * 2017C , MF-U * 3017C and MF-U * 4020C is moved particularly rearward on the Y axis (toward the column), exercise care so that a workpiece or a fixture will not interfere with the main unit.
-

IMPORTANT Since the clamp is used only to prevent the workpiece from moving during measurement, there is no need for extensive joint strength. An excessive clamping force will deform a workpiece if it is made of thin or soft material, and a correct measurement result may not be obtained. Use a clamping method that will not deform the workpiece.

- TIP**
1. The swivel center support (No.172-197), V-block with clamp (No.172-378), and holder with clamp (No.176-107) are also available optionally to fix a workpiece.
 2. To secure a workpiece and fixture to the XY stage, use the tapped holes on the stage. The stage adapter (B)(No.176-310) is used for MF-U * 2010C, and the stage adapter (No.176-304) is used for MF-U * 2017C, MF-U * 3017C and MF-U * 4020C to be secured on the stage with tapped holes as shown below. The fixture is secured using T-groove of the adapter.

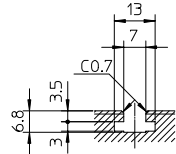

Stage adapter T-groove dimension figure

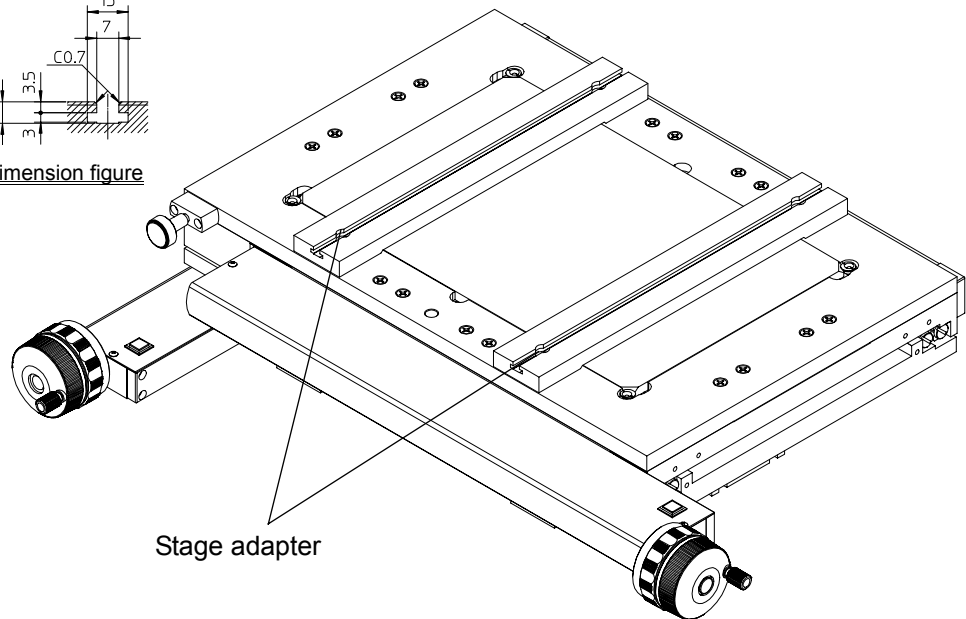

Stage adapter

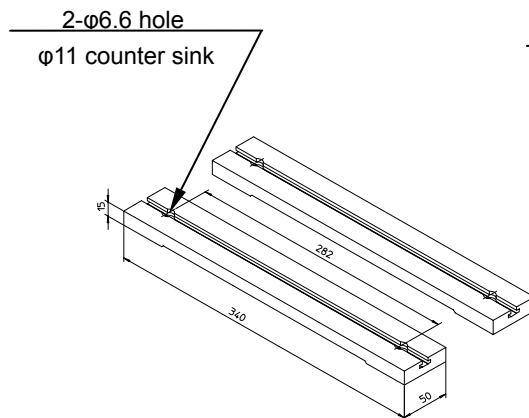

Stage adapter

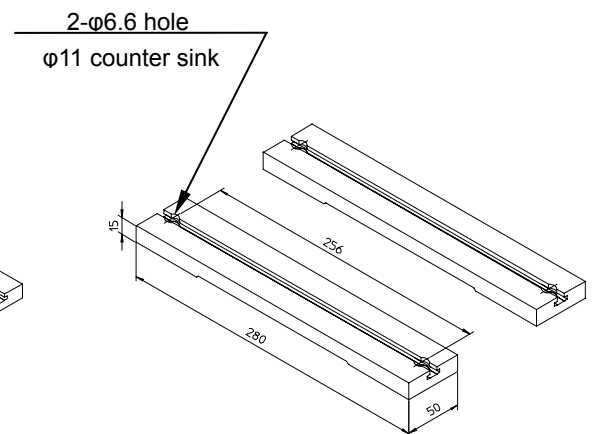

Stage adapter (B)

Stage adapter dimension figure

3. For information about the dimensions of stages, refer to the XY stage in "6.8 External Dimensions".

3.9 Selecting the Illumination Method

Select the appropriate illumination method depending on the type of workpiece.

3.9.1 Transmitted illumination

Used for the contour measurement and inspection. A telecentric system ^(*1) is employed. The aperture diaphragm knob for transmitted illumination enables to adjust the brightness and obtain the optimal aperture when measuring cylindrical workpieces. There are continuous illumination intensity settings available. A maximum of two filters can be mounted.

TIP **(*1) What is telecentric system? Illumination which placed the optical system so that the image center size may not change by the image growing faint, even if the focus deviates in the optic axis direction. The magnification error by the focusing does not occur.**

3.9.2 Vertical reflected illumination

Used for surface measurement and inspection. (The surface should not be excessively rough). A Koehler system ^(*2) is employed and its advantages are fully utilized when measuring the surface of mirror finish workpiece.

TIP **(*2) What is Koehler system? Illumination which placed the optical system so that the illumination light (image) is not directly imaged on the observation plane and the whole observation range is evenly irradiated by the uniform parallel light with high brightness.**

3.9.3 Simultaneous use of transmitted and vertical reflected illumination

The transmitted and vertical reflected illumination modes can be used simultaneously. This enables to measure the contour and surface feature of workpiece can be observed at the same time.

3.10 Selecting a Filter

Filters are attached to the transmitted illumination unit. Select those filters according to the usage.

Symbol	Filter type	Function and usage
L B 8 0	Color temperature conversion filter	Referred to as a light balance filter (LB filter). When the voltage of the halogen lamp is lowered to reduce the light intensity, the entire light of the lamp becomes red due to decrease in short-wavelength light. This filter converts the color temperature of the lamp to that of near natural light by reducing the transmission of long-wavelength light. This filter has an advantage in observation and capture of color images under the reflected illumination environment.
N D 2	Neutral filter (light)	Referred to as a neutral density filter. This filter is intended to reduce light in the visible region with no wavelength sensitivity. It is used for reducing the light intensity without lowering the color temperature of a light source. The ND2 filter will reduce the light intensity to 1/2 and the ND8 will reduce it to 1/8. This filter is effective in observation and capture of color images under the reflected illumination environment.
N D 8	Neutral filter (dark)	
G I F (※)	Green interference filter	One of interference filters with multi-layer films evaporated. This filter transmits only green spectral wavelength light with a central wavelength of 540nm and a half-width of 70nm. The filter provides a bright illumination with its greater half-width and transmittance, compared with a glass green filter. Particularly, this filter is used for increasing the resolution and contrast of images under the transmitted illumination environment.

(※) Standard accessories

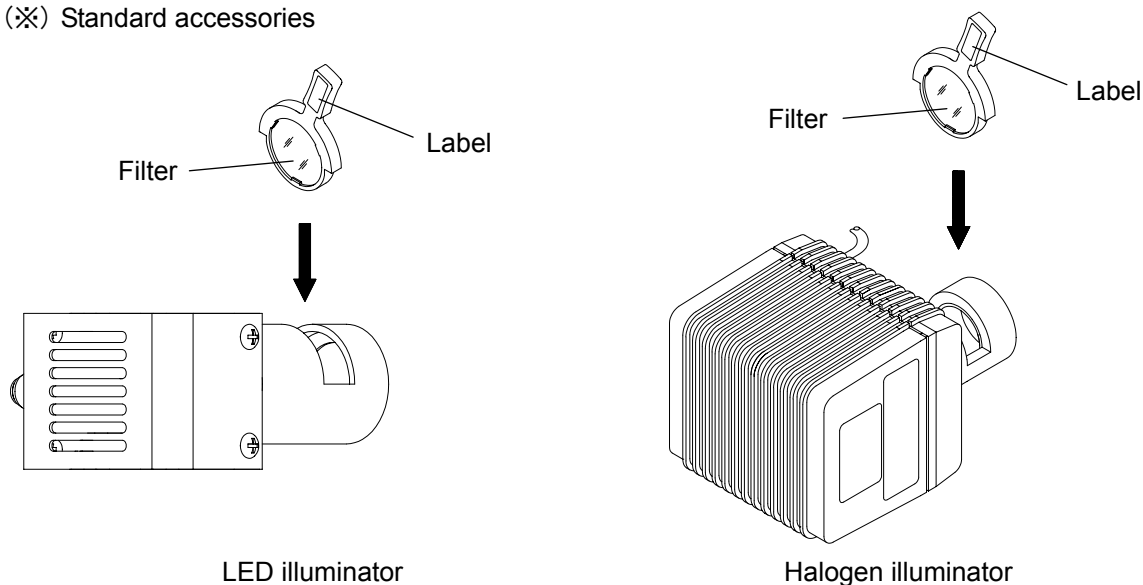

NOTE The illuminator housing is very hot. Be careful when installing the filter.

TIP Color temperature denotes the temperature of the complete black body that produces the same chromaticity as that of a light source under consideration. Turning a light source red refers to lowering the color temperature and turning it blue refers to raising the color temperature.

3.11 Adjusting the Pupil Distance

Look through the eyepieces at the correct viewing angle and hold the binocular tubes with both hands. Adjust the angle between the tubes to your eyes by moving them in the directions shown below.

- Adjustable range of pupil distance : 51~76mm

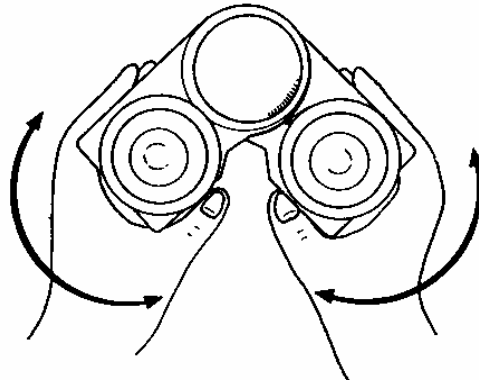

-
- NOTE** 1. The eyepieces employ a high-eye-point system with rubber eye cups attached. Turn the rims outward, as shown in the below figure, if you wear eyeglasses.

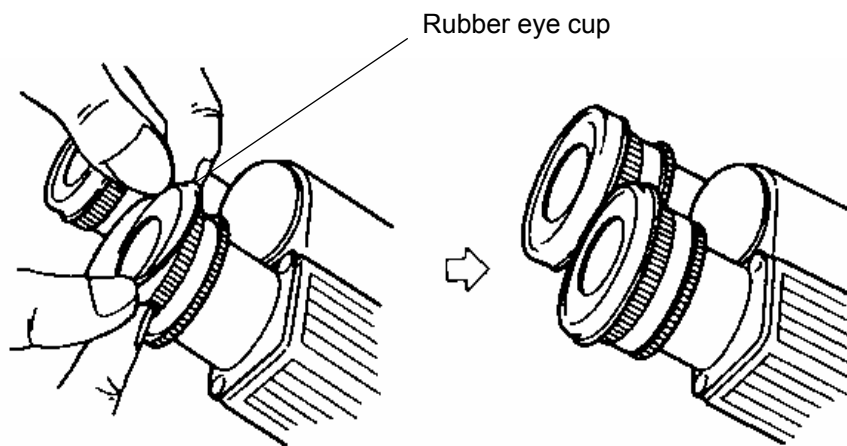

2. The binocular unit is supplied with polyethylene caps to shut off the light from the eyepieces during use of the TV port and for dust-preventive purpose during storage. (The cap is also supplied for the monocular unit.) Cover each polyethylene cap over the eye shade on individual eyepieces. If the eye shade is removed from the eyepiece, a play will be generated between the cap and eyepiece. Exercise a great care.
-

3.12 Adjusting the Diopter of Eyepiece

Adjust the diopter following below procedure.

- ① Hold the root of eyepiece by the hand to prevent the whole eyepiece from rotating during adjustment.
- ② Turn the diopter adjustment ring of eyepiece with the other hand to bring the cross-hair line into sharp focus.

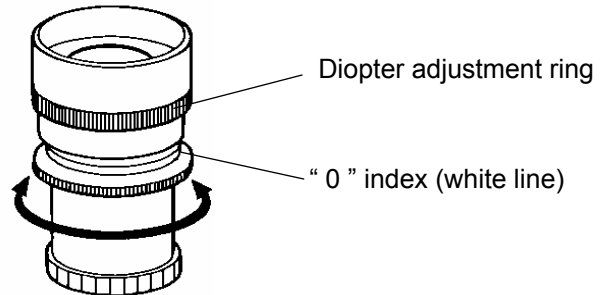

3.13 Replacing the Reticle

Insert the reticle unit into the slot on the side of optical tube unit to project the chart on the real image.

Insert the unit all the way into the slot with the fingertip hooking groove on the reticle unit orienting backward.

The reticle cover is made of rubber, so it can be removed with fingers.

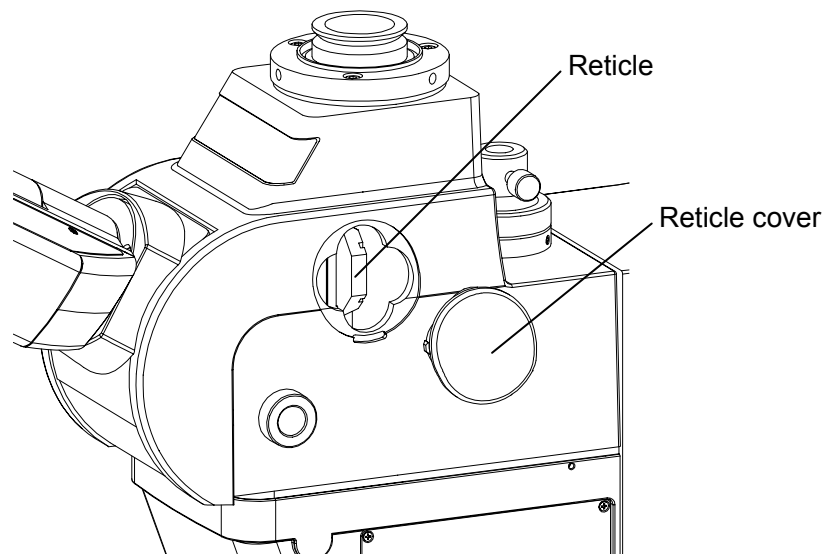

- NOTE**
1. The reticle unit should always be inserted in the slot. If the reticle unit is not inserted, an error may occur in the diopter.
 2. If the reticle unit is not completely inserted all the way into the slot, the shading may occur.
 3. The reticle cover should always be equipped. The dust may come inside of the optical tube if leave the reticle unit without the cover

3.14 Dimensional Measurement

The dimension of a workpiece is determined from the displacement of the XY stage .
The basic measuring procedure is as follows.

- ① Move the XY stage as one edge of workpiece meets the cross-hair.

Dimension to be measured

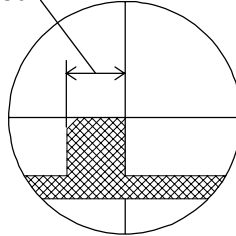

- ② Press the zero button of the X-axis to set the counter zero.



- ③ Move the XY stage as the other edge of workpiece meets the cross-hair.

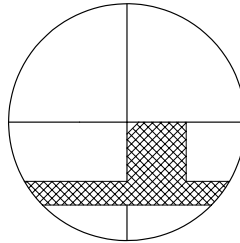

- ④ Take a reading from the counter.



Dimension is displayed.

3.15 Polarized Observation

To observe the optical characteristics specific to a workpiece with double refraction, etc., use the polarization unit (polarizer and analyzer) in the optional accessories and follow the procedure below.

Insert the polarizer in the polarizer slot on the rear right side of the optical tube and the analyzer in the analyzer slot on the front right side, all the way until they stop.

The analyzer has a 360° rotatable knob to act as a parallel Nicol prism with the bright field of view and as a crossed Nicol prism with the dark field of view. If the polarizer is attached, the brightness of the visual field decreases even in the state of parallel Nicol prism.

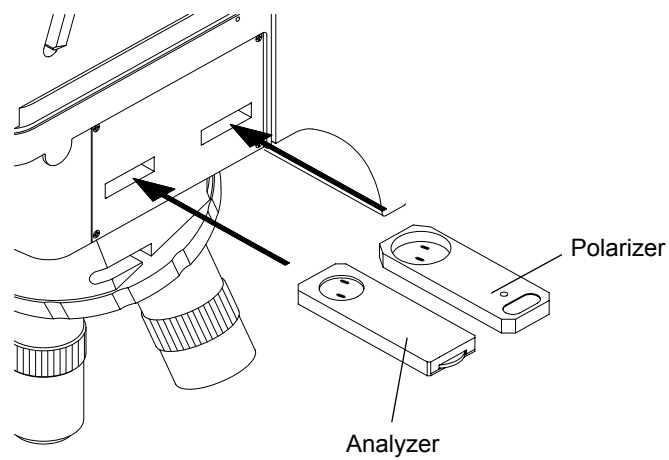

3.16 Differential Interference Observation

To observe in-depth surface textures such as minute scratches, steps, and irregularities on a workpiece, use the polarization unit and differential interference unit (DIC unit) in the optional accessories and follow the procedure below.

- ① Attach the polarizer and the analyzer according to the procedure in “3.15 Polarized Observation”.
- ② Place a specimen on the XY stage, select an objective, and then give an appropriate illumination.
- ③ Operate the coarse/fine focus wheel on the optical tube to focus on the surface of the specimen.
- ④ Rotate the knob on the analyzer to put the visual field under observation (eyepiece inside or video screen) in the darkest state (crossed Nicol state).
- ⑤ Insert a DIC unit compatible with the objective being used in the DIC slot on the right side of the measuring unit, all the way until it stops.
- ⑥ Turning the knob on the DIC unit will change the interference color (background color).

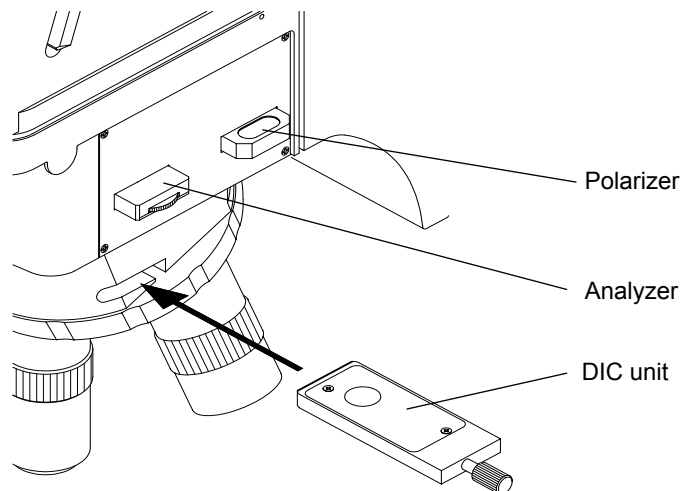

NOTE Adjust the illumination brightness as necessary. Depending on the characteristics of a specimen or the setting of observation magnification, however, it may be difficult to observe the interference color due to insufficient brightness even at the maximum brightness.

3.17 Switching Bright/Dark-Field Reflection Observation (Applied only to the bright/dark-field type)

This measuring microscope is provided with the function of dark-field observation in order to observe surface textures such as minute scratches, steps, and irregularities that are difficult to view under bright-field observation. To perform dark-field observation, use the optional bright/dark-field objective and pull out the bright/dark-field switching knob to install the dark-field illumination. This allows dark-field observation. Also, fully open the aperture diaphragm.

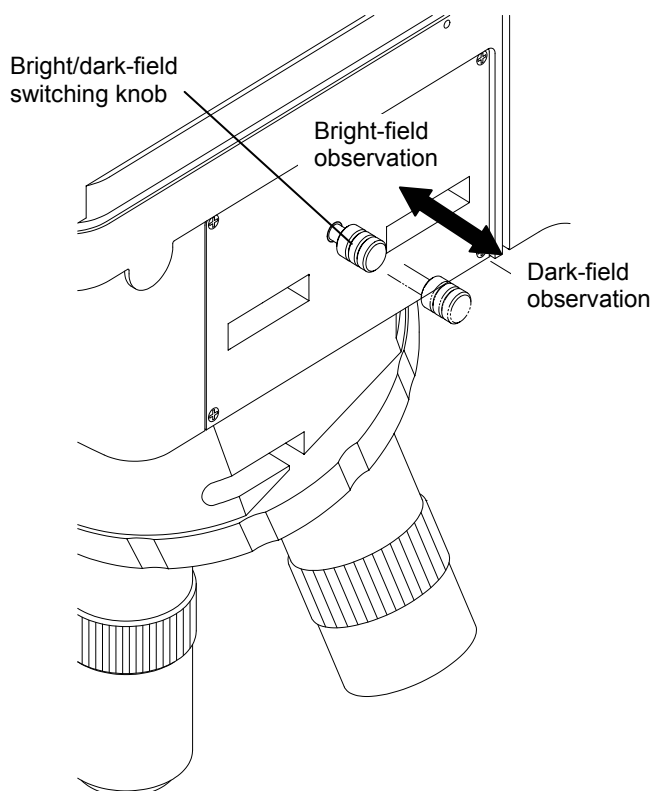

- TIP** In dark-field observation a workpiece is illuminated with a light beam larger than the NA (numerical aperture) of the objective. Therefore, the illumination light will not enter in the field of view, making the background dark. This allows clear observation of minute scratches, steps, irregularities, etc., due to dispersion of light.
- TIP** When switching between the bright-field observation and bright/dark-field observation, be sure to move the switching knob all the way to the stroke end. Although the illumination fiber image may be seen in process of switching, it does not disturb either observation.

MEMO

4

Maintenance

This chapter explains the daily maintenance that must be performed on the Measuring Microscope MF-U series, including cleaning and the replacement of consumables.

4.1 Cleaning External Parts

Gently wipe the contaminations from the main unit and stage glass with a soft cloth. If the contaminations are persistent, wipe them carefully with a cloth soaked in a diluted neutral detergent and tightly squeezed, then wipe dry with another cloth.

IMPORTANT Do not use benzene, thinner, or chemically treated cloth for cleaning since the surface may discolor and the paint may peel.

4.2 Maintaining the Lens

Always keep the lens clean and free of dust, oil, and fingerprints. If the lens got contaminated, wipe them according to the following procedure:

- Dust : Gently wipe it with a clean lens brush, soft brush, or gauze.
- Oil, fingerprints: Gently wipe with tissue paper for the lens or a gauze dampened with a small amount of absolute alcohol (ethanol, methanol) .

IMPORTANT To maintain optimal Measuring Microscope performance over an extended period, it should be periodically inspected by a Mitutoyo service engineer. For detailed information, contact your dealer or the nearest Mitutoyo service center.

4.3 Replacing Consumables

Consumables including halogen bulb and stage glass should be replaced by the user. Perform maintenance work safely by observing the replacement procedure described below.

4.3.1 Replacing halogen bulbs for Transmitted illuminator

- ① Turn off the power to the system.
- ② Let the lamp and its surrounding area cool down by leaving the power on for approx. 30 minutes.

IMPORTANT The bulbs and the peripherals stay hot for a period after use. Be sure to perform the above procedures and check that the bulbs have cooled, then proceed to the next step.

- ③ Turn off the main power switch and pull out the power cord.

IMPORTANT Serious injury and risk of electrocution will result if cover is opened while power is on.

- ④ Loosen and remove two fixing screws for the head cover of illuminator (cross recessed pan head screws) by a supplied Philips screw driver.

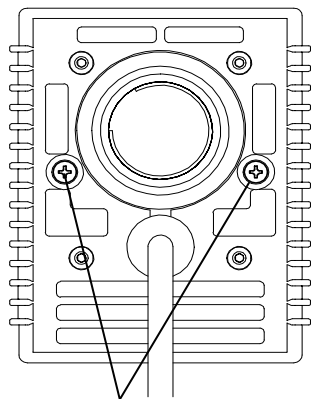

Fixing screws for head cover

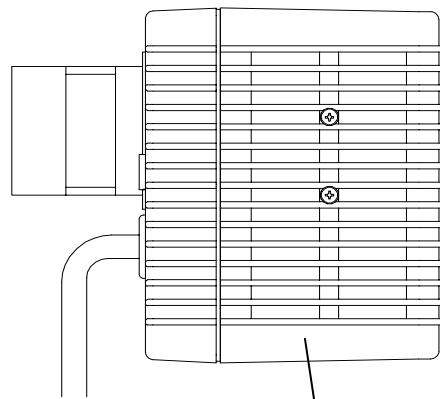

Head cover

- ⑤ Pull straight the old bulb, and then insert the new one into the socket. Do not touch the bulb directly with the bare hand, otherwise the glass surface is contaminated with the oil etc., resulting in the short life of the bulb.
- Insert the bulb all the way until it reaches the end of the socket. If not inserted well enough, uniform illumination can not be obtained.

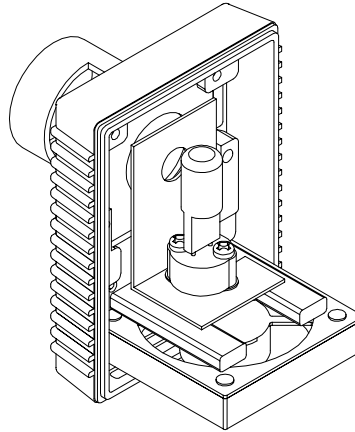

IMPORTANT Use only the specified halogen bulbs.

Unspecified halogen bulb may prevent the machine from performing efficiently.

TIP For information about the halogen bulbs type, refer to "6.3 List of Consumable".

4.3.2 Replacing halogen bulbs for Reflected illuminator

When replacing the halogen bulb, refer to "Fiber-optic illumination" User's manual.

4.3.3 LED illuminator replacement

The operating life of the LED illuminator is approximately 30,000 hours. If the illuminator is darker or not lighted, replace the LED illuminator assembly.

- (1) Set the light quantity of each bulb to 0%, and cool down the illuminator in the power-on state for approximately 10 minutes.

IMPORTANT Use of the illuminator may cause high temperatures. Be sure to perform the procedure below after turning off the power and confirming that the bulb is cooled.

- (2) Turn off the main power switch and pull out the power cord.

IMPORTANT Replacement operation in the power-on state may cause trouble resulting in harm to the operator.

- (3) Remove the connector of the LED illuminator from the rear of the main unit base.
- (4) Remove the illuminator unit from the microscope main unit.
- (5) Connect the connector of a new LED illuminator to the main unit base and the LED illuminator unit to the microscope main unit.

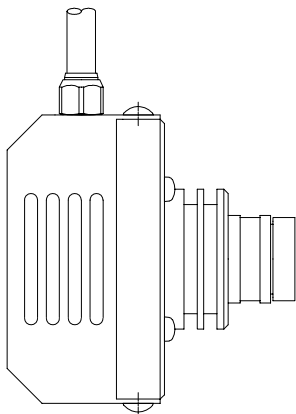

[LED reflected illuminator (U)]

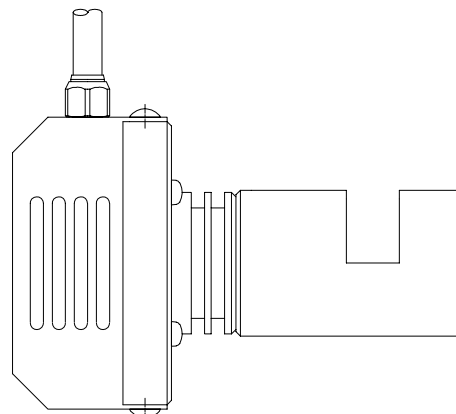

[LED transmitted illuminator]

TIP For information about the LED illuminator, refer to "6.3 Consumables".

4.3.4 Replacing the stage glass

- ① Loosen the fixing screws (4 pieces) to remove them along with each glass retainer.
- ② Remove the stage glass from the cross-travel stage.
- ③ Gently fit a new stage glass in the frame of the stage.
- ④ Carefully tighten the fixing screws so the stage glass will not move.

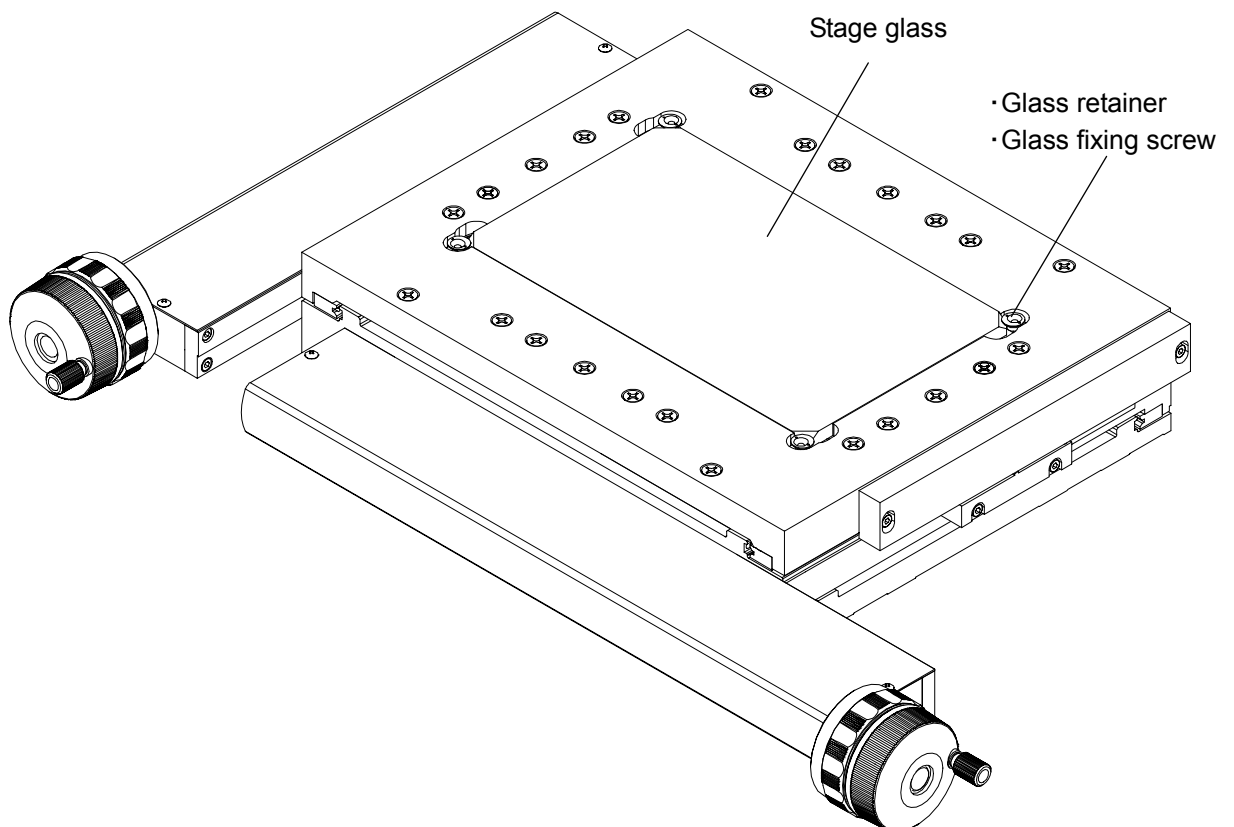

NOTE If replacing the stage glass, be careful so as not to break it.

Do not touch directly the stage glass with your bare hands due it is easy to get contaminated by fingerprints etc. Wear gloves.

4.3.5 Replacement of conston spring

- (1) Move the optical tube upward, place an appropriate spacer under the optical tube for fall prevention.
- (2) Remove the rear cover from the column.
- (3) Insert a driver into the work hole of the spring bracket, pull the conston spring upward, and disengage the wire from the pulley.
- (4) Move back the conston spring to the position where the spring is shortest.
- (5) Loosen the cross recessed truss-head screw and disengage the wire. (Pay attention not to lose the collar.)
- (6) Loosen the hexagon nut (M6) and remove the spring bracket and conston spring.
- (7) Loosen the hexagon socket head cap screws (2 pieces, M3), remove the shaft from the column, and replace the conston spring.
- (8) Put back the shaft to the column.
- (9) Put the spring bracket and conston spring together with a gap maintained using the hexagon socket head cap screws (2 pieces) and hexagon nuts (2 pieces). (If there is no gap, the wire cannot be evenly pulled.)
- (10) Engage the wire with the spring bracket using the cross recessed truss-head screw and collar.
- (11) Insert a driver into the work hole of the spring bracket, pull the conston spring upward, and engage the wire with the pulley.
- (12) Put back the rear cover to the column.

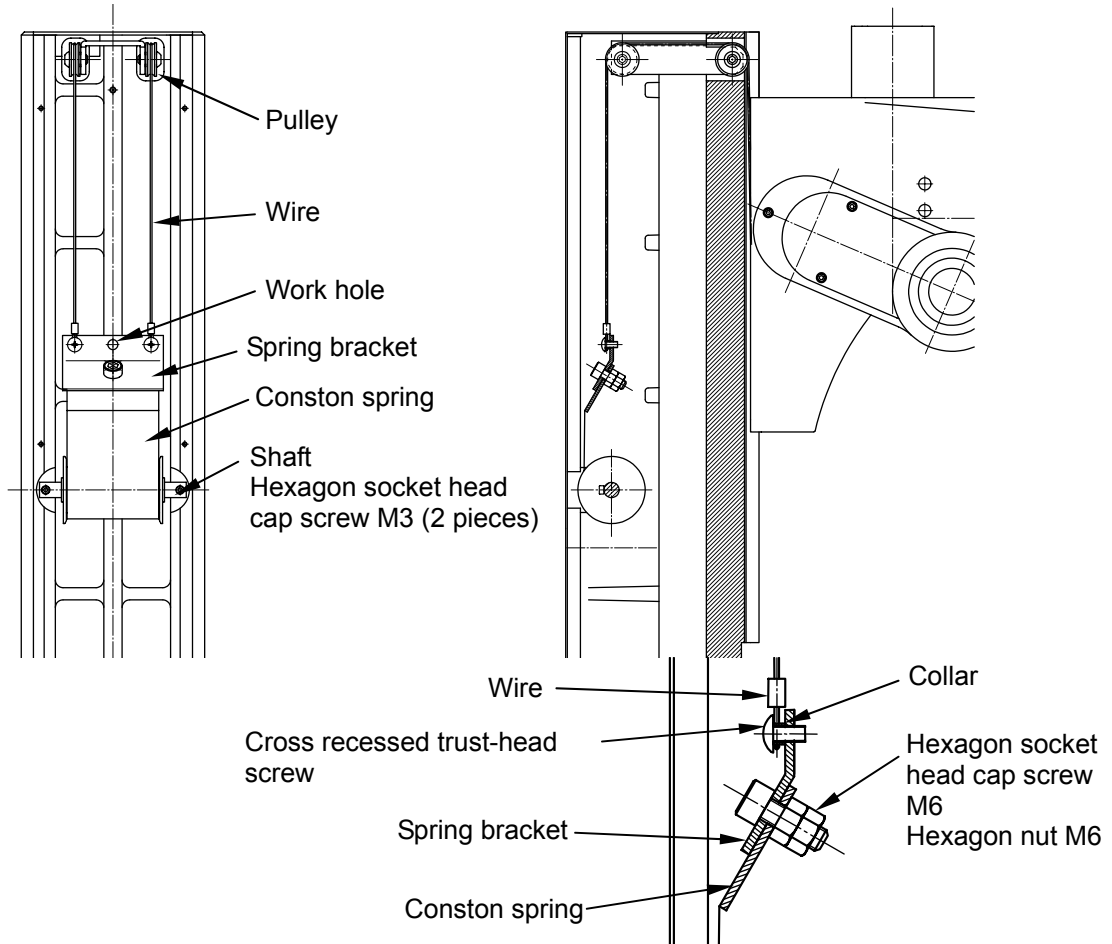

IMPORTANT Use caution not to hurt your fingers with the edge of the conston spring.

NOTE Prepare a hexagon wrench (nominal size 5) and a spanner (nominal size 10) for putting hexagon socket head cap screws and hexagon nuts in addition to the standard tools (accessories).

5

Troubleshooting

This chapter describes the check points and remedies if a symptom of trouble in the Measuring Microscope system is encountered.

5.1 Main Unit

	Symptom	Check point	Remedy
1)	Nothing is Displayed on the counter when the power switch is on.	1) Is the power cord securely connected? 2) Is the cable connected correctly between the microscope main unit and controller? 3) Is the main power switch turned on? 4) Is the auxiliary power switch turned on?	1) Connect the power cord securely. 2) Disconnect the cable once and re-connect it securely. 3) Turn on the main power switch. 4) Turn on the auxiliary power switch.
2)	The image is unclear.	1) Check if the lens and workpiece are stained. 2) Check if the light intensity of the illumination is improper. 3) Check if the lens is loosened. 4) Check the environments for vibration and electric noise.	1) Clean the lens and workpiece. 2) Adjust the light intensity. 3) Tighten the lens. 4) Optimize the environmental conditions.
3)	Abnormal sound and vibration are generated.	1) Check if the legs on the main unit/installation stand are loose. 2) Check if the main unit/installation stand is not level.	1) Tighten the legs on the main unit/installation stand correctly. 2) Perform leveling of the main unit/installation stand.
4)	The measurement data will not be steady.	1) Check if the stage glass is fixed. 2) Check if the lens is loosened. 3) Check if the workpiece is fixed properly. 4) Check if the lens and glass are contaminated. 5) Check if the environmental conditions such as the temperature and vibration are within the tolerance range.	1) Fix the stage glass 2) Tighten the lens. 3) Fix the workpiece properly. 4) Clean the lens and glass. 5) Optimize the environmental conditions.
5)	The optical tube unit is stiff in the vertical motion.	1) Remove the rear cover on the column and check the Conston spring (constant force spring) for abnormality such as broken wire.	1) If the Conston spring (constant force spring) is proved to reach the end of its life, contact your dealer or the nearest Mitutoyo sales office.
6)	The buzzer keeps sounding.	1) The buzzer keeps sounding from the controller.	1) Refer to "5.4 Error Messages and remedies" – "5.4.2 Illuminator and concerned matters".

5.2 Counter Unit

	Symptom	Check point	Remedy
1)	Nothing is displayed on the counter when the power switch is on.	1) Is the power cord securely connected? 2) Is the cable connected correctly between the microscope main unit and controller? 3) Is the main power switch turned on? 4) Is the auxiliary power switch turned on?	1) Connect the power cord securely. 2) Disconnect the cable once and re-connect it securely. 3) Turn on the main power switch. 4) Turn on the auxiliary power switch.
2)	Counter display is locked (no counting.)	1) Turn the power switch off, then turn it on after at least 5 seconds.	1) Try a few times. If the counter still does not count, contact your dealer or the nearest Mitutoyo sales office.
3)	Miscounting	1) Is the wire from the main unit GND terminal grounded securely? Is the connecting unit free from rust and paint? 2) Is there any noise source nearby? 3) See "Counter display is locked" category in Malfunction column.	1) Securely ground the wire from the main unit GND terminal. 2) The counter should be separated by at least 0.5m from high-voltage or large-current sources and high-capacity relays. 3) If the counter or any Linear Scale is found to be damaged, contact your dealer or the nearest Mitutoyo sales office.
4)	Count value fluctuates	1) Are vibrations affecting the Linear Scales? 2) Is the mounting stand strong enough?	1) Take countermeasures to minimize the effects of the vibration. 2) Confirm the strength of the mounting stand on which the microscope is installed.
5)	Errors of "E20" and "F30" are displayed.	1) Refer to "5.4 Error Messages and Remedies".	
6)	Errors of "E51" and "E52" and "E53" are displayed.	1) Refer to "5.4 Error Messages and Remedies". 2) Have the power switches been turned on or off according to the note of "3.2 Turning the Power Supply On"?	1) Refer to "5.4 Error Messages and Remedies". 2) Turn the power switches on or off in the following order. • For ON Peripheral equipment → Microscope main unit • For OFF Microscope main unit → Peripheral equipment

5.3 Illuminator and Concerned Matters

	Symptom	Check point	Remedy
1)	Dark or unlighted transmitted illuminator/vertical reflected illuminator	<p>[LED illuminator] 1) The illuminator is dark or unlighted.</p> <p>[Halogen illuminator] 1) Is the halogen bulb OK? 2) Does the halogen bulb meet the specification?</p> <p>[Common to LED/Halogen illuminator] 1) Is the power cord disconnected? 2) Is the main unit connected to the illuminator properly? 3) Is the main power switch turned on? 4) Is the auxiliary power switch turned on? 5) Is the cable for each illuminator properly connected? 6) Is the cooling fan of each illuminator working? 7) Is the installation environment of the microscope kept at a proper temperature? 8) Is the illuminator energy saving activated?</p>	<p>1) If the symptom is not solved after disconnecting the illuminator once and reconnecting it, replace the LED illuminator. (Contact your dealer or the nearest Mitutoyo sales office.)</p> <p>1) Replace the halogen bulb. 2) Replace the bulb with new bulb with the same rating.</p> <p>1) Disconnect the illuminator once and re-connect it securely. 2) Disconnect the illuminator once and re-connect it securely.</p> <p>3) Turn on the main power switch. 4) Turn on the auxiliary power switch. 5) Disconnect the cable once and re-connect it securely. 6) Restart the power of the microscope. If the same symptom occurs, contact Mitutoyo Service Center. 7) Turn off the power of the microscope, then turn it on again at least 10 minutes later. 8) Set the " F10 " counter parameter to " 0:None ". (Refer to " About parameters " explained in selection 1.2.4 " DRO Counter Unit ", Section 1.2 " Name and Function of Each Unit".)</p>
2)	Disabled optional illuminator at use of vision unit	1) The optional illuminator does not work with QSPAK VUE appropriately.	1) Check whether the control cable of the external illuminator is connected to the counter unit. (Refer to "1.2 Name and Function of Each Part" - "1.2.4 Counter unit".)
3)	Ceaseless buzzer	1) The buzzer keeps sounding from the controller.	1) Refer to "5.4 Error Messages and Remedies" – "5.4.2 Illuminator and concerned matters".

5.4 Error Messages and Remedies

5.4.1 Counter and concerned matters

LED display	Meaning and remedy
E20	Overspeed arising ; Traverse speed of the axis which displayed the error is too fast. ... Press the zero-set button of the axis which displayed the error or restart the microscope main unit.
F30	Overcount arising ; The scale of the axis which displayed the error exceeds the possible counting range. ... Return the scale of the axis which displayed the error to the possible counting range or restart the microscope main unit.
E51	RS232C parity error ... Press the X-axis zero-set button or send C0 (zero) command by RS-232C from peripheral devices such as PC. Restart both of the peripheral devices and the microscope main unit when the communication is not resumed.
E52	RS232C over-run error ... Press the X-axis zero-set button or send C0 (zero) command by RS-232C from peripheral devices such as PC. Restart both of the peripheral devices and the microscope main unit when the communication is not resumed.
E53	RS232C framing error ... Press the X-axis zero-set button or send C0 (zero) command by RS-232C from peripheral devices such as PC. Restart both of the peripheral devices and the microscope main unit when the communication is not resumed.

TIP When an error code has been cleared (power is turned on), the counter displays all zeros. Perform measurement from the start.

5.4.2 Illuminator and concerned matters

An error detected in the illuminator section is observed with the LED blinking (green) of “the auxiliary power switch” on the control panel with buzzers generated from the controller.

When an error is detected, the LED of the auxiliary power switch blinks after a buzzer. Buzzers and blinking repeat at intervals of 20 seconds.

Buzzer count	Auxiliary switch LED blink count	Cause and remedy
2 times (beep)	2 – off – 2	<ul style="list-style-type: none"> • The overcurrent protection circuit of the fan integrated into the transmitted illuminator or reflected illuminator functions. ··· Turn off the main power and start the system after a while. If the same error is detected again, contact your dealer or the nearest Mitutoyo sales office.
	2 – off – 3	<ul style="list-style-type: none"> • The fan integrated into the reflected illuminator is restrained or the connector of the fan is not connected. ··· Turn off the main power and check whether a foreign object interferes with the fan, or disconnect the connector of the illuminator and connect it again. If the same error is detected again, contact your dealer or the nearest Mitutoyo sales office.
	2 – off – 4	<ul style="list-style-type: none"> • The fan integrated into the transmitted illuminator is restrained or the connector of the fan is not connected. ··· Turn off the main power and check whether a foreign object interferes with the fan, or disconnect the connector of the illuminator and connect it again. If the same error is detected again, contact your dealer or the nearest Mitutoyo sales office.
3 times (beep)	3 – off – 2	<ul style="list-style-type: none"> • The LED reflected illuminator is not connected correctly. ··· Turn off the main power, disconnect the connector of the LED reflected illuminator, and connect it again.
	3 – off – 3	<ul style="list-style-type: none"> • The LED transmitted illuminator is not connected correctly. ··· Turn off the main power, disconnect the connector of the LED reflected illuminator, and connect it again.
	3 – off – 7	<ul style="list-style-type: none"> • The cable inside the control panel breaks. ··· If the same error is detected again after turning off the main power, contact your dealer or the nearest Mitutoyo sales office.

IMPORTANT To cancel an error, be sure to turn off the main power switch first and treat the matter.

MEMO

6

Specifications

This chapter describes the specifications, standard accessories, and optional accessories of the Measuring Microscope.

6.1 Common Specifications

Model No.	Bright field	2 Axes type	MF-UA505C	MF-UA1010C	MF-UA2010C	MF-UA2017C	MF-UA3017C	MF-UA4020C
		3 Axes type	MF-UB505C	MF-UB1010C	MF-UB2010C	MF-UB2017C	MF-UB3017C	MF-UB4020C
	Bright/dark field	2 Axes type	MF-UC505C	MF-UC1010C	MF-UC2010C	MF-UC2017C	MF-UC3017C	MF-UC4020C
		3 Axes type	MF-UD505C	MF-UD1010C	MF-UD2010C	MF-UD2017C	MF-UD3017C	MF-UD4020C
Optical tube		<ul style="list-style-type: none"> Erecting trinocular tube Built-in 1X fixed tube lens Erect image Optical path fixed type: Observation / TV = 50 / 50 Vertical tilt angle: 0 to 30 degrees Reticle: 90° broken-cross line (line width 5µm) Pupil distance adjustment: Siedentop type, adjustable range: 51 to 76 mm (2.0" to 3.0") 						
Eyepiece unit		<ul style="list-style-type: none"> Magnification: 10X Field Number: ϕ 24 mm Diopter adjustable 						
Illuminator unit (Option: requisite selection)	LED illuminator	<ul style="list-style-type: none"> Transmission: Telecentric system Built-in aperture diaphragm White LED light source Non-step light intensity control with Air-cooling fan Reflection: Bright field/Dark field Koehler illumination with Adjustable aperture diaphragm White LED light source Non-step light intensity control with Air-cooling fan Control unit: Main power ON/OFF switch (main switch) AC power inlet connector 100-240V 						
	Halogen illuminator	<ul style="list-style-type: none"> Transmission: Telecentric system Built-in aperture diaphragm Halogen bulb 12V, 50W Non-step light intensity control with Air-cooling fan Reflection: Bright field/Dark field Koehler illumination with Adjustable aperture diaphragm Control unit: Main power ON/OFF switch (main switch) AC power inlet connector 100-240V 						
Transmitted illumination filter		<ul style="list-style-type: none"> Detachable/attachable green filter : 1 piece supplied 						
Control panel		<ul style="list-style-type: none"> Power switch (accessible sub switch for operation) Adjustable aperture diaphragm (Transmitted) Transmitted illuminator: OFF~Non-step Reflected illuminator: OFF~Non-step 						
Z-axis	Traverse range	150 mm (5.9")				220 mm (8.7")		
	Feeding mechanism	<ul style="list-style-type: none"> 1-axis coarse / fine feed Both left / right wheel (coarse: 10 mm(0.39") / full-turn, fine: 0.1 mm(0.004") / full-turn) 						
Cross-travel stage	Traverse range	50×50mm (2.0" X 2.0")	100×100mm (3.9" X 3.9")	200×100mm (7.9" X 3.9")	200×170mm (7.9" X 6.7")	300×170mm (11.8" X 6.7")	400×200mm (15.7" X 7.9")	
	Stage surface dimensions	280×280mm (11.0" X 11.0")	280×280mm (11.0" X 11.0")	350×280mm (13.8" X 11.0")	410×342mm (16.1" X 13.5")	510×342mm (20.1" X 13.5")	610×342mm (24.0" X 13.5")	
	Stage glass dimensions	180×180mm (7.1" X 7.1")	180×180mm (7.1" X 7.1")	250×150mm (9.8" X 5.9")	270×240mm (10.6" X 9.4")	370×240mm (14.6" X 9.4")	440×240mm (17.3" X 9.4")	
	Quick release mechanism	Built-in at both X-axis and Y-axis						
	Indication Accuracy	(2.2+0.02L) µm L : Measuring length (mm): Compliant with the measuring method of JIS B 7153						
	Table rotating function	None				with Swivel mechanism ±5°		±3°
	Maximum load	10kg (22.1 lb)	10kg (22.1 lb)	10kg (22.1 lb)	20kg (44.1 lb)	20kg (44.1 lb)	15kg (33.1 lb)	
Counter	Number of axes	3 axes or 2 axes						
	Resolution	0.001 / 0.0005 / 0.0001mm (0.0001 / 0.00005 / 0.00001") switchable						
	Function	Zero setting / Direction mode selection / RS-232C output						

Dimensions	562x730x667 22.1"x28.7"x26.2"	562x730x667 22.1"x28.7"x26.2"	624x745x667 24.6"x29.3"x26.2"	632x892x782 24.8"x35.1"x30.8"	682x892x782 26.9"x35.1"x30.8"	757x907x782 29.8"x35.7"x30.8"
Weight of main unit	65.5kg (144 lb)	65.5kg (144 lb)	69.5kg (153 lb)	130kg (286 lb)	138kg (304 lb)	144kg (317 lb)
Weight of control unit	2.0 kg (4.4lb)					
Max. power consumption	LED	55 W				
	Halogen	90 W				

6.2 Standard Accessories

6.2.1 Standard accessories for measuring microscope main unit

Order No.	Item name	Quantity
378-866	10x eyepiece (2 piece)	1
12AAA645	GIF filter	1
380893	Polyethylene cap ϕ 41.5	2
12BAK408	Fiber collar	1
99MBA092J	User's Manual (Japanese)	1 (select any one kind)
99MBA092A	User's Manual (English)	
99MBA092C	User's Manual (simplified Chinese)	
472730	Warranty	1
382951	Dust cover	1
512926	Cap (2010 less)	4 (select any one kind)
12BAC490	Cap (2017 over)	
12BAD487	Hanger bolt (2010 less)	4 (select any one kind)
12BAG808	Hanger bolt (L) (2017 over)	
12BAG897	Setting piece (2017 over)	5
538615	Allen wrench (nominal 2.5)	1
538616	Allen wrench (nominal 3)	1
353491	Philips screwdriver	1

6.2.2 Standard accessories for illuminator

02ZAA000	Power cord (home)	1 (select any one kind)
02ZAA010	Power cord (UL, CSA)	
02ZAA020	Power cord (CEE)	
02ZAA030	Power cord (BS)	
02ZAA040	Power cord for CCC	
02ZAA050	Power cord SP-023+IS14 (KOREA)	
513667	Halogen bulb (12V, 50W) ※1	2 (only for halogen type)
12AAJ770	Extension cable for halogen power supply (transmitted)	1 (only for halogen type)
1126-0105	Ferritic core	1 (only for halogen type) (mounted on 12AAJ770)

※1: The lamp used for this instrument is designed for special purpose, and not suitable for household room illumination.

6.3 List of Consumables

Part name	Product No.	Remark
Halogen bulb (12 V, 50 W) ※1 (High-bright type)	513667	For transmitted illumination (Made by NARVA Co., 57901)
Halogen bulb (12 V, 50 W) ※1 (Long life type)	12BAB345	For transmitted illumination (Made by OSRAM Co., 64602)
Halogen bulb (12 V, 100 W) (High-bright type)	12BAD602	For 100 W light source Made by Iwasaki Electric Co., JCR12V100W)
Halogen bulb (12 V, 100 W) (Long life type)	517181	For 100 W light source Made by Iwasaki Electric Co., JCR12V100W10H)
Halogen bulb (15 V, 150 W) (High-bright type)	12BAJ075	For 150 W illumination (Made by Moritex Co., LM-150)
Halogen bulb (15 V, 150 W) (Long life type)	12BAJ076	For 150 W illumination (Made by Moritex Co., LM-150C)
Stage glass	12BAD381	For MF-U * 505C
Stage glass	12BAD381	For MF-U * 1010C
Stage glass	12BAD760	For MF-U * 2010C
Stage glass	12BAD363	For MF-U * 2017C
Stage glass	12BAD330	For MF-U * 3017C
Stage glass	12BAH968	For MF-U * 4020C
Conston spring	12BAD284	
LED transmitted illuminator	12AAJ720	For transmitted illumination (with air-cooling fan)
LED reflected illuminator (U)	12AAJ731	For vertical reflected illumination (with air-cooling fan)

※1: The lamp used for this instrument is designed for special purpose, and not suitable for household room illumination.

6.4 Optional accessories

○: applicable, -: not applicable

No.	Part name	MF-U*505C	MF-U*1010C	MF-U*2010C	MF-U*2017C	MF-U*3017C	MF-U*4020C
378-857	Eyepiece 15×	○	○	○	○	○	○
378-858	Eyepiece 20×	○	○	○	○	○	○
—	Objective	○	○	○	○	○	○
375-067 ※1	# Focus pilot FP-05U	○	○	○	○	○	○
12AAA165	Lens cleaning set	○	○	○	○	○	○
375-056	Objective micrometer	○	○	○	○	○	○
176-107	Holder with clamp	○	○	○	○	○	○
172-378	V-block & clamp	○	○	○	○	○	○
176-305	Rotary stage with fine feed knob (A)	○	○	○	—	—	—
176-306	Rotary stage with fine feed knob (B)	—	—	—	○	○	○
176-308	Vibration damping stand	○	○	○	○	○	○
176-309	Mounting stand	○	○	○	○	○	○
—	Various reticle	○	○	○	○	○	○
378-080	Differential interference contrast unit	for 5x and 10x	○	○	○	○	○
378-079		for 20x	○	○	○	○	○
378-078		for 50x and SL20x	○	○	○	○	○
378-076		for 100x, SL50x and SL80x	○	○	○	○	○
378-092	Polarization unit	○	○	○	○	○	○
176-211	Revolver (BF/BD) ※3	○	○	○	○	○	○
378-210 ※1	Power revolver (BF/BD) ※3	○	○	○	○	○	○
378-018	Adjustable revolver ※4	○	○	○	○	○	○
378-016 ※1	Power revolver (BF) ※4	○	○	○	○	○	○
378-116 ※1	Power revolver (BF)	○	○	○	○	○	○
176-316 ※1	150 W fiber-optic illuminator	○	○	○	○	○	○
176-315 ※1	● 100 W fiber-optic illuminator	○	○	○	○	○	○
176-343 ※1 ※5	● Twin fiber illuminator	○	○	○	○	○	○
12AAG806	○ GIF filter (for 100W illumination)	○	○	○	○	○	○
12AAG807	○ LB80 filter (for 100W illumination)	○	○	○	○	○	○
375-054	★ 0.5x camera adapter unit	○	○	○	○	○	○
970441	★ C-mount adapter	○	○	○	○	○	○
172-197	◇ Swivel center support	○	○	○	○	○	○
176-304	◆ Stage adapter	—	—	—	○	○	○
176-310	◆ Stage adapter (B)	—	—	○	—	—	—
264-145 ※1	△ QM-Data200	○	○	○	○	○	○
12AAA807	▲ RS-232C cable	○	○	○	○	○	○
359-739	□ Vision unit 9UB (export)	○	○	○	○	○	○
12AAD128 ※5	■ External light source control cable (for 100W light source)	○	○	○	○	○	○
12AAG888	■ External light source control cable (for 150W light source)	○	○	○	○	○	○
176-346 ※2	◎ LED illuminator (MF-U)	○	○	○	○	○	○
176-348 ※1	◎ Halogen illuminator (MF-U)	○	○	○	○	○	○
12AAA643	ND2 filter ※2 (light quantity: 50%)	○	○	○	○	○	○
12AAA644	ND8 filter ※2 (light quantity: 13%)	○	○	○	○	○	○
12AAA646	LB80 filter ※2	○	○	○	○	○	○

When ☆ is used, use together ★ C-mount or 0.5x adapter unit.

○ is dedicated option for ● illuminator.

When △ is used, also use ▲ RS-232C cable.

When ◇ is used, use together ◆ Stage adapter (only 200x100, 200x170, 300x170, 400x170).

When □ Vision unit is used, use together with either one of ■ External light source control cables.

Use of ■ External light source control cable allows 150W / 100W of fiber-optic illuminator to be controlled with the volume on the front panel of the microscope.

Hold with clamp, V-block & clamp, Swivel center support can be attached on Rotary stage with fine feed knob (A).

mark is factory set option.

※1:Order No. is different by using line voltage.

※2 is for halogen illuminator.

※3 is for bright/dark field (UC and UD) type.

※4 is for bright field (UA and UB) type.

※5:When Twin fiber illuminator (176-343) is controlled with the Vision unit, External control cable (12AAD128) is required.

6.5 Objectives, Tube Lens, Eyepieces Specification Table

<FS UL WD Series>

M plan apochromat objective (for bright-field)					Eyepiece WF, wide field of view								
					WF10×24			WF15×/16			WF20×/12		
					Tube lens 1×			Tube lens 1×			Tube lens 1×		
M	N.A.	W.D.	f	R (μm)	T.M.	φ	F.D. (μm)	T.M.	φ	F.D. (μm)	T.M.	φ	F.D. (μm)
1×	0.025	11	200	11.0	10×	24	1011.0	15×	16	821.0	20×	12	725.7
2×	0.055	34	100	5.0	20×	12	220.8	30×	8	177.5	40×	6	155.8
5×	0.14	34	40	2.0	50×	4.8	34.4	75×	3.2	27.6	100×	2.4	24.2
10×	0.28	33.5	20	1.0	100×	2.4	8.6	150×	1.6	6.9	200×	1.2	6.1
20×	0.42	20	10	0.7	200×	1.2	3.3	300×	0.8	2.7	400×	0.6	2.4
50×	0.55	13	4	0.5	500×	0.48	1.4	750×	0.32	1.3	1000×	0.24	1.2
100×	0.70	6	2	0.4	1000×	0.24	0.8	1500×	0.16	0.7	2000×	0.12	0.7

<FS UL WD SL Series>

M plan apochromat objective (for bright-field)					Eyepiece WF, wide field of view								
					WF10×24			WF15×/16			WF20×/12		
					Tube lens 1×			Tube lens 1×			Tube lens 1×		
M	N.A.	W.D.	f	R (μm)	T.M.	φ	F.D. (μm)	T.M.	φ	F.D. (μm)	T.M.	φ	F.D. (μm)
SL20×	0.28	30.5	10	1.0	200×	1.2	6.1	300×	0.8	5.2	400×	0.6	4.8
SL50×	0.42	20.5	4	0.7	500×	0.48	2.2	750×	0.32	2.0	1000×	0.24	1.9
SL80×	0.50	15	2.5	0.55	800×	0.3	1.6	1200×	0.2	1.3	1600×	0.15	1.3
SL100×	0.55	13	2	0.5	1000×	0.24	1.2	1500×	0.16	1.1	2000×	0.12	1.0
SL200×	0.62	13	1	0.4	2000×	0.12	0.8	3000×	0.08	0.8	4000×	0.06	0.8

<FS UL WD Series>

BD plan apochromat objective (for bright- and dark-field)					Eyepiece WF, wide field of view								
					WF10×24			WF15×/16			WF20×/12		
					Tube lens 1×			Tube lens 1×			Tube lens 1×		
M	N.A.	W.D.	f	R (μm)	T.M.	φ	F.D. (μm)	T.M.	φ	F.D. (μm)	T.M.	φ	F.D. (μm)
2×	0.055	34	100	5.0	20×	12	220.8	30×	8	177.5	40×	6	155.8
5×	0.14	34	40	2.0	50×	4.8	34.4	75×	3.2	27.6	100×	2.4	24.2
10×	0.28	33.5	20	1.0	100×	2.4	8.6	150×	1.6	6.9	200×	1.2	6.1
20×	0.42	20	10	0.7	200×	1.2	3.3	300×	0.8	2.7	400×	0.6	2.4
50×	0.55	13	4	0.5	500×	0.48	1.4	750×	0.32	1.3	1000×	0.24	1.2
100×	0.70	6	2	0.4	1000×	0.24	0.8	1500×	0.16	0.7	2000×	0.12	0.7

<FS UL WD SL Series>

BD plan apochromat objective (for bright- and dark-field)					Eyepiece WF, wide field of view								
					WF10×24			WF15×/16			WF20×/12		
					Tube lens 1×			Tube lens 1×			Tube lens 1×		
M	N.A.	W.D.	f	R (μm)	T.M.	φ	F.D. (μm)	T.M.	φ	F.D. (m)	T.M.	φ	F.D. (m)
SL20×	0.2 8	30. 5	10	1.0	200×	1.2	6.1	300×	0.8	5.2	400×	0.6	4.8
SL50×	0.42	20.5	4	0.7	500×	0.48	2.2	750×	0.32	2.0	1000×	0.24	1.9
SL80×	0.50	15	2.5	0.55	800×	0.3	1.6	1200×	0.2	1.3	1600×	0.15	1.3
SL100×	0.55	13	2	0.5	1000×	0.24	1.2	1500×	0.16	1.1	2000×	0.12	1.0

Note) M : Magnification
 N.A. : Numerical aperture
 W.D. : Working distance (mm)
 f : Focal distance (mm)
 R : Resolution (μm)
 T.M. : Total magnification
 φ : Field of view (φ mm)
 F.D. : Focal depth (μm)

Assuming that the resolution of human eye is 2'

$$R = \frac{\lambda}{2 \times \text{N.A.}} \quad \lambda = 0.55 \mu\text{m} \text{ (Standard wavelength)}$$

$$\text{F.D.} = \frac{\lambda}{2 (\text{N.A.})^2} + \frac{1000}{7 \times \text{N.A.} \times \text{T.M.}}$$

6.6 Layout of the Optical System

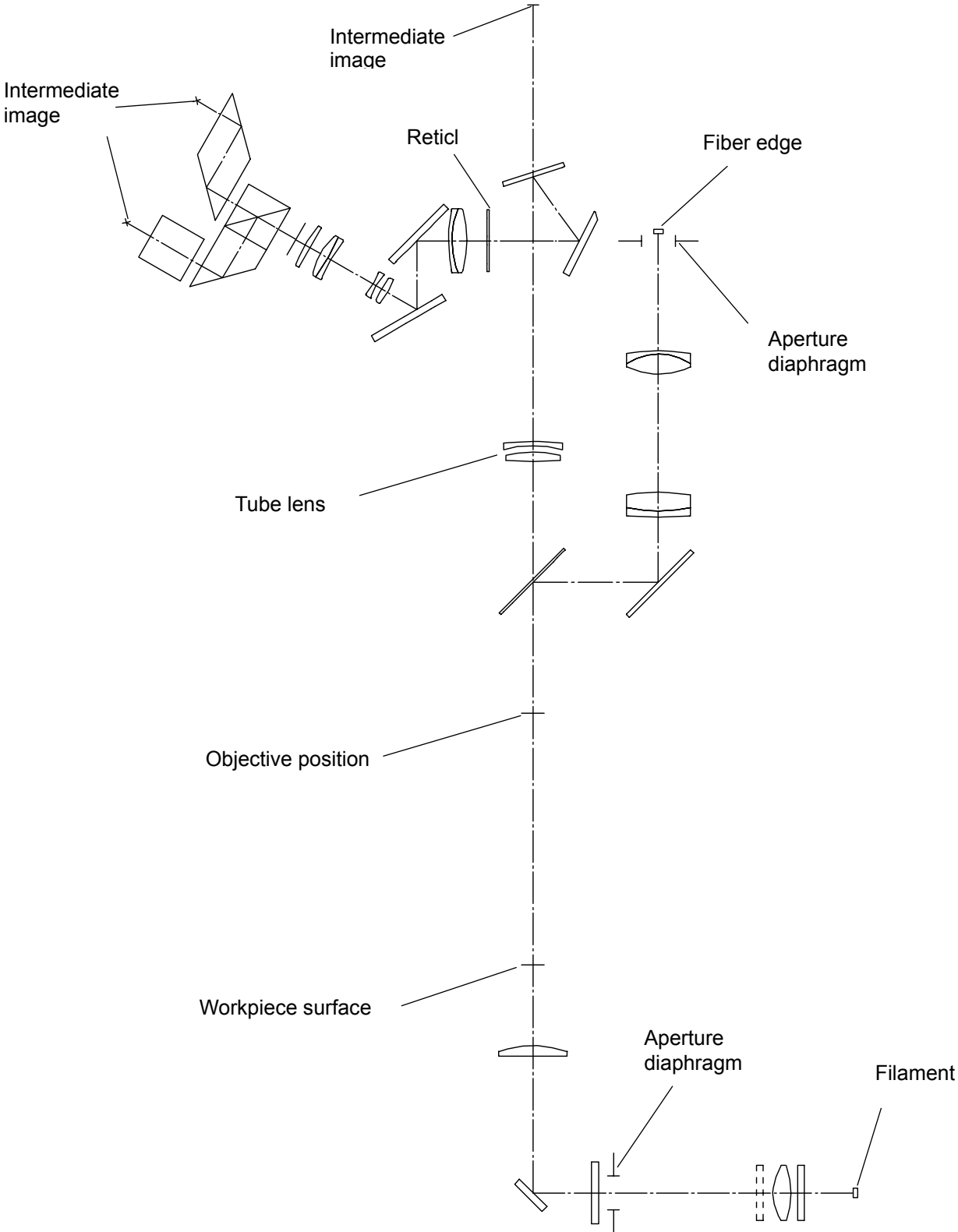

6.7 Serial Data Output Specifications of the Counter

The measured date of the counter unit is output via the serial output connector to a peripheral, such as two-dimensional data processing unit Micropak 9/7 or two-dimensional data processing program QSPAK.

Communication Specifications

- Transmission method : Half duplex
- Transmission control : Asynchronous (Start-stop transmission)
- Baud rate : 1200bps/2400bps/4800bps/9600bps^(※1)/19200bps
- Data bit : 7 bits^(※1)/8 bits ASCII
- Parity bit : Even^(※1)/Odd/None
- Stop bit : 1 bit^(※1)/2 bits
- Flow control : Enabled/Disabled^(※1)

(※1) Default setting at the shipment

6.7.1 Connector specifications

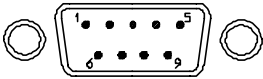
Connector shape	Pin number	Signal	I/O direction ※2	Description
 D-sub, 9 pins, male, inch thread	1			
	2	RD	IN	Accept the command
	3	TD	OUT	Measured data
	4	DTR	OUT	Counter is ready
	5	SG	—	Signal ground
	6	DSR	IN	Peripheral is ready
	7	—	—	
	8	—	—	
	9			
	FG	—	—	Frame ground

(※2) In/Out direction OUT : Counter → Peripheral

The input/output circuits used are equivalent to MAX232 (MAXIM Corporation).

6.7.2 Control signal

A data request from a peripheral is accepted only if the DTR signal is “H” (space).
 “H” has a +9V level.

The counter unit can transfer only if the DSR signal is “H” (space).

Example of cable that can be used

The following illustrates two types of reference cables which are used to connect the counter to a DOS/V PC. One of the cables does not use control lines and other uses control lines.

Cable 1 (Control lines are not used)

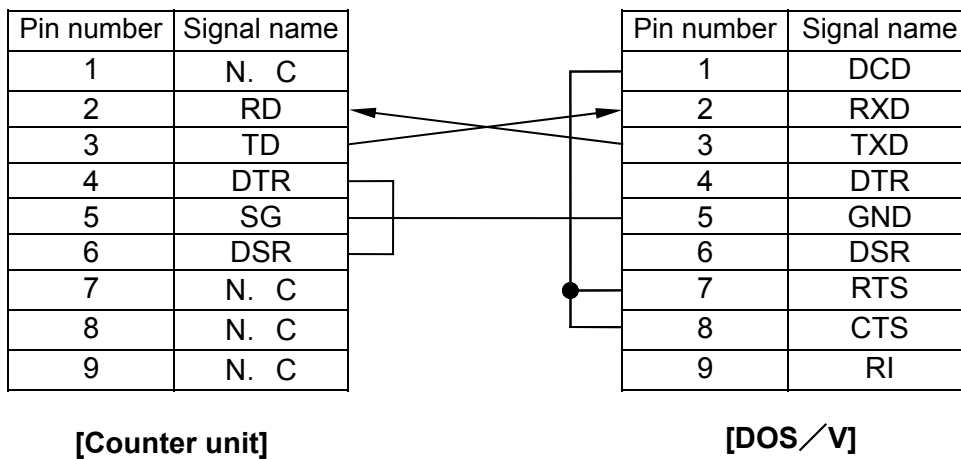

Cable 2 (Control lines are used)

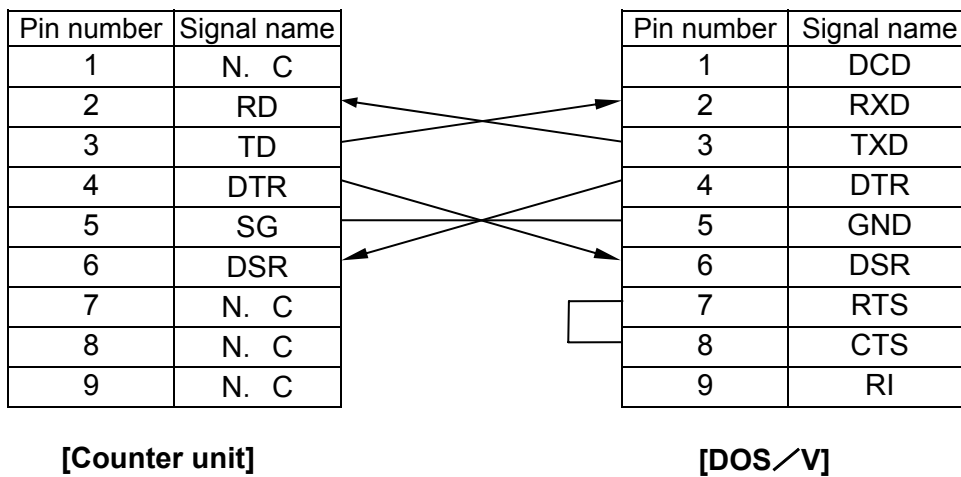

6.7.3 Data output operation

A displayed value on the counter unit can be output by inputting an external load signal or commands from a peripheral, such as a personal computer.

(1) Data output

A) For the external load signal

Only the data on the axis on which the external load box switch is pressed is output to a peripheral.

B) For the command from peripheral

Data is output to a peripheral by inputting the following character strings (commands) from the peripheral, such as a personal computer.

List of command from peripheral

Input command			Output data
X	CR	LF	X-axis data
Y	CR	LF	Y-axis data
Z	CR	LF	Z-axis data
A	CR	LF	Three-axes data

(2) Output format

The Output data is output in the specified format.

Below are given output examples of various kinds of data for a signal-axis counter and multi-axes counter.

1) Single-axis counter output

A) If “123.4567” is displayed on the X-axis counter

X		+	1	2	3	.	4	5	6	7	CR	LF
---	--	---	---	---	---	---	---	---	---	---	----	----

B) If “0.0000” is displayed on the Y-axis counter

Y		+	0	0	0	.	0	0	0	0	CR	LF
---	--	---	---	---	---	---	---	---	---	---	----	----

2) Multi-axes counter output

A coordinate data of each axis is the same as the output format of a single-axis counter.

For two-axes)

X-axis data	,	Y-axis data	CR	LF
-------------	---	-------------	----	----

For three-axes)

X-axis data	,	Y-axis data	,	Z-axis data	CR	LF
-------------	---	-------------	---	-------------	----	----

3) Summary of external device data and output data

By pressing the switch on the external load box or upon reception of commands from the peripheral, the counter unit outputs the following data.

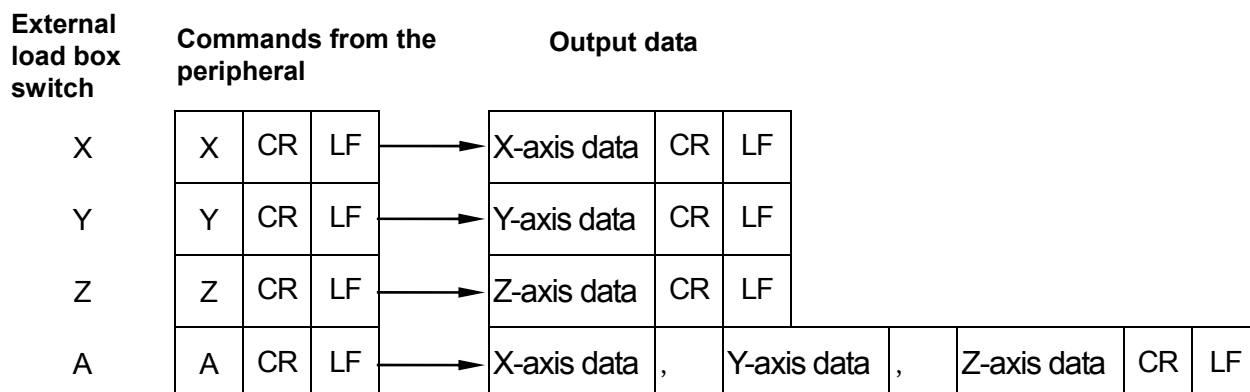

4) Error

Next error code is output, when the error arises in the counter.

RS-232C error code	Display	Error cause	Remedy (method of return)
N G 0 5 CR LF	E51	Parity error arising	1) Press the X-axis zero-set button. 2) Transmit C0 (zero) command from the peripheral equipment at RS-232C.
N G 0 7 CR LF	E52	Over-run error arising	
N G 0 8 CR LF	E53	Framing error arising	
N G 0 9 CR LF	—	Receiving the undefined command	Correspond by the normal command.
X E 2 0 CR LF	E20	X-axis overspeed arising	1) Press the X-axis zero-set button. 2) Transmit C0 (zero) command.
Y E 2 0 CR LF	E20	Y-axis overspeed arising	1) Press the Y-axis zero-set button. 2) Transmit C0 (zero) command.
Z E 2 0 CR LF	E20	Z-axis overspeed arising	1) Press the Z-axis zero-set button. 2) Transmit C0 (zero) command.
X F 3 0 CR LF	F30	X-axis overcount arising	Return to the range in which the counting is possible.
Y F 3 0 CR LF	F30	Y-axis overcount arising	
Z F 3 0 CR LF	F30	Z-axis overcount arising	

TIP The error with high priority is displayed, when the multiple error phenomena arises simultaneously. If the error is canceled by C0 (zero) command, etc., the error with next high priority is displayed.

6.7.4 Connecting Micropak

It is necessary to perform the Micropak 9 / 7 / 5mk II setting when connecting the Micropak to the counter unit.

For information about setting up Micropak 9 / 7 / 5mk II , refer to the Micropak user's manual.

(1) Connection

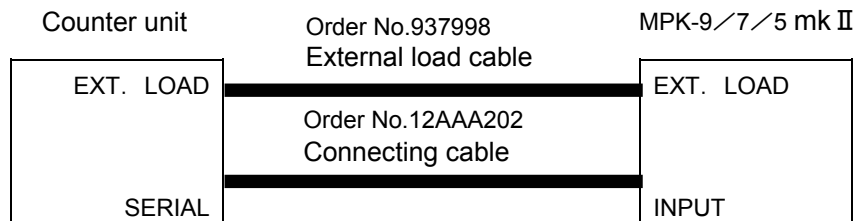

(Set No.12AAA500
for two pieces of above mentioned cable)

(2) Micropak 9 setup

- ① Set Equipment-->Counter-->Baud Rate-->9600 bps
- ② Set Equipment-->Counter-->X-axis Counter-->RS-232C Connection
Y-axis Counter-->RS-232C Connection
Z-axis Counter-->RS-232C Connection
- ③ Set Equipment-->Counter-->Counter connected-->MF
- ④ Set Conditions-->Measuring Rang-->X Y Z

(3) Micropak 7 setup

- ① Set Equipment-->Counter-->Baud Rate-->9600 bps
- ② Set Equipment-->Counter-->X-axis Counter-->RS-232C Connection
Y-axis Counter-->RS-232C Connection
Z-axis Counter-->RS-232C Connection
- ③ Set Equipment-->Counter-->Counter connected-->Others-->Counter (100ms)
- ④ Set Conditions-->Measuring Rang-->X Y Z

(4) Micropak 5mk II setup

Set the Dip switch DPS1 and DPS2 according to the following.

- ① DPS1 No.1 : ON, No.2 : OFF, No.3 : OFF, No.4 : OFF 4800 bps
- ② DPS2 No.5 : ON, No.6 : OFF

Modify also the parameter setup of the MF counter simultaneously. (Set "4800 bps" at the parameter number F07-1 according to "1.2.4.1 About parameters".)

NOTE To connect the counter to Micropak 5mk II , unless the default setting are modified, the counter cannot be connected to Micropak 5mk II . (Because MPK-5mk II does not accept the Z-axis data.) Modify also the parameter setup of the counter so that Z-axis output may not be performed. (Set "2 AS" at the parameter number F08 according to "1.2.4.1 About parameters".)

6.7.5 Connecting DPU-414 (Printer)

(1) Software DIP SW 1-3 setting

Notice : Do not turn off power while during start up setting. (The procedure cannot be skipped.)

Remark : Set the [FEED] key off, and the [ON LINE] key on.

Key operation	Contents of printout	Remarks
Turn the power switch "ON" pressing the [ON LINE] key	Automatically print the present DPU-414 setting. At the last line, the prompts are printed as below: Continue ? :Push 'On-line SW' Write ? :Push 'Paper feed SW'	Start startup setting
[ON LINE]	Dip SW-1	Setting of SW1
[FEED] [ON LINE] [ON LINE] [FEED] [ON LINE] [FEED] [ON LINE] [ON LINE]	(off)(on)(on)(off) (on)(off)(on)(on) Continue ? :Push 'On-line SW' Write ? :Push 'Paper feed SW'	Input method: Serial CR=CR Printing density = 100%
[ON LINE]	Dip SW-2	Setting of SW2
[ON LINE] [ON LINE] [ON LINE] [ON LINE] [ON LINE] [ON LINE] [ON LINE] [ON LINE]	(on)(on)(on)(on) (on)(on)(on)(on) Continue ? :Push 'On-line SW' Write ? :Push 'Paper feed SW'	Normal printing (40 columns) Japanese
[ON LINE]	Dip SW-3	Setting of SW3
[FEED] [FEED] [FEED] [FEED] [FEED] [ON LINE] [ON LINE] [ON LINE]	(off)(off)(off)(off) (off)(on)(on)(on) Continue ? :Push 'On-line SW' Write ? :Push 'Paper feed SW'	Data bit length: 7 bits Parity permission: Even number Baud rate: 9600 bps
[FEED]	Dip SW setting complete!!	Complete setting

(2) Printing operation

- 1) Turn on the "ON LINE" lamp by pressing the [ON LINE] key, then start printing with the MF foot switch (option).
- 2) Turn off the "ON LINE" lamp by pressing the [ON LINE] key, then press the [FEED] key to feed paper.
- 3) Turn the power switch "ON" pressing the [FEED] key to start test printing.

(3) Connection

Connect each cable as figure below. Be sure that all power sources of each equipment are OFF when connecting cables.

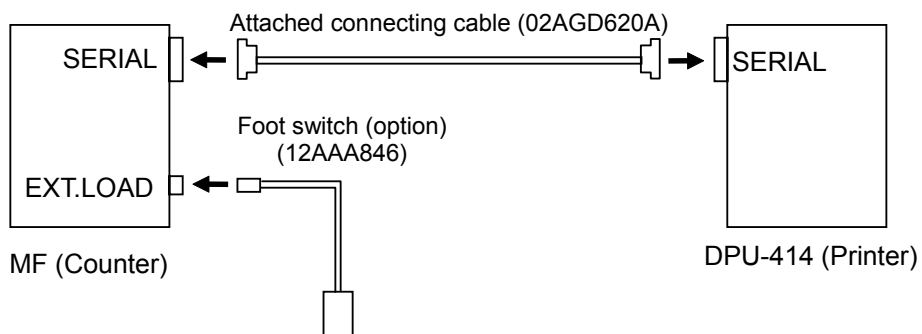

(4) Setting and operation of MF counter

①Setting

Default setting up of MF counter at shipment has no need to be changed, however, confirm the communication condition setting of MF counter if printing does not start.

②Printing operation

Pressing the foot switch (option) enables to print the value of the axis on which is set up output by MF counter.

6.7.6 Connecting QM-Data 200

It is necessary to perform the QM-Data 200 setting when connecting it to the counter unit.
For information about setting up QM-Data 200, refer to its user's manual.

(1) Connection

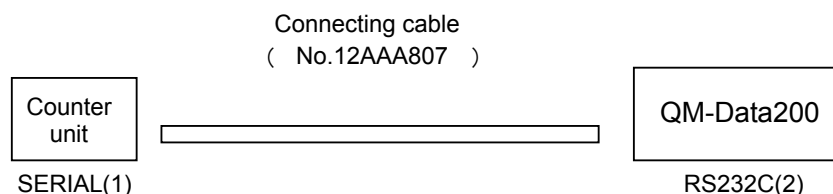

(2) QM-Data 200 setting

- ① Select the "SYSTEM" key of operation panel.
- ② 5: Measuring Instrument Setting--> 1: Counter Type--> MF-A/MF-UA

After the selection, the external counter setting of QM-Data 200 becomes the following communication condition:

- Baud Rate: 9600 bps
- Communication Condition: EVEN, 7, 1
- Flow Control: DTR/DSR
- Terminator: CR+LF

- ③ 2: Axis Configuration--> 1: X, Y or 2: X, Y, Z, (depending on the axis configuration of the microscope)

NOTE When QM-Data 200 starts, the counter display of microscope goes off and LED of mm/E display at the counter blinks on and off. The switches on the microscope counter become ineffective.

TIP A value in units of "E" is displayed by dividing a displacement in units of "mm" by 25.4.

6.8 External Dimensions

6.8.1 main unit

(unit : mm)

a) MF-U * 505C

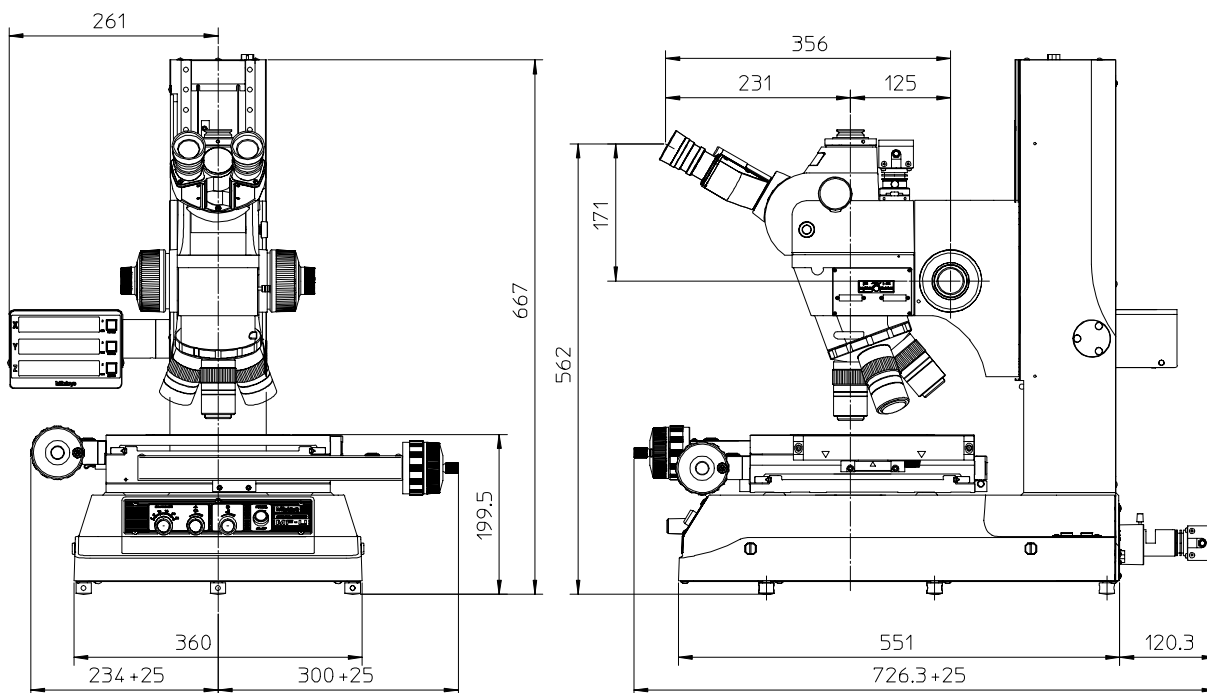

b) MF-U * 1010C

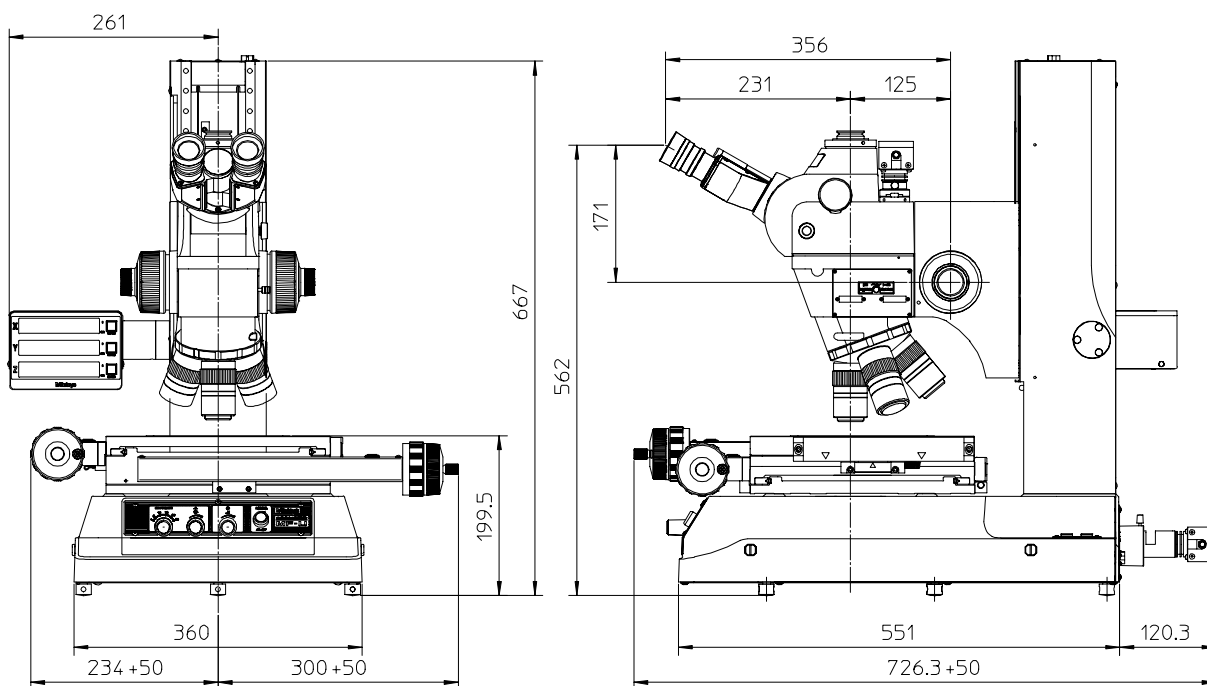

6. Specifications

c) MF-U * 2010C

(unit : mm)

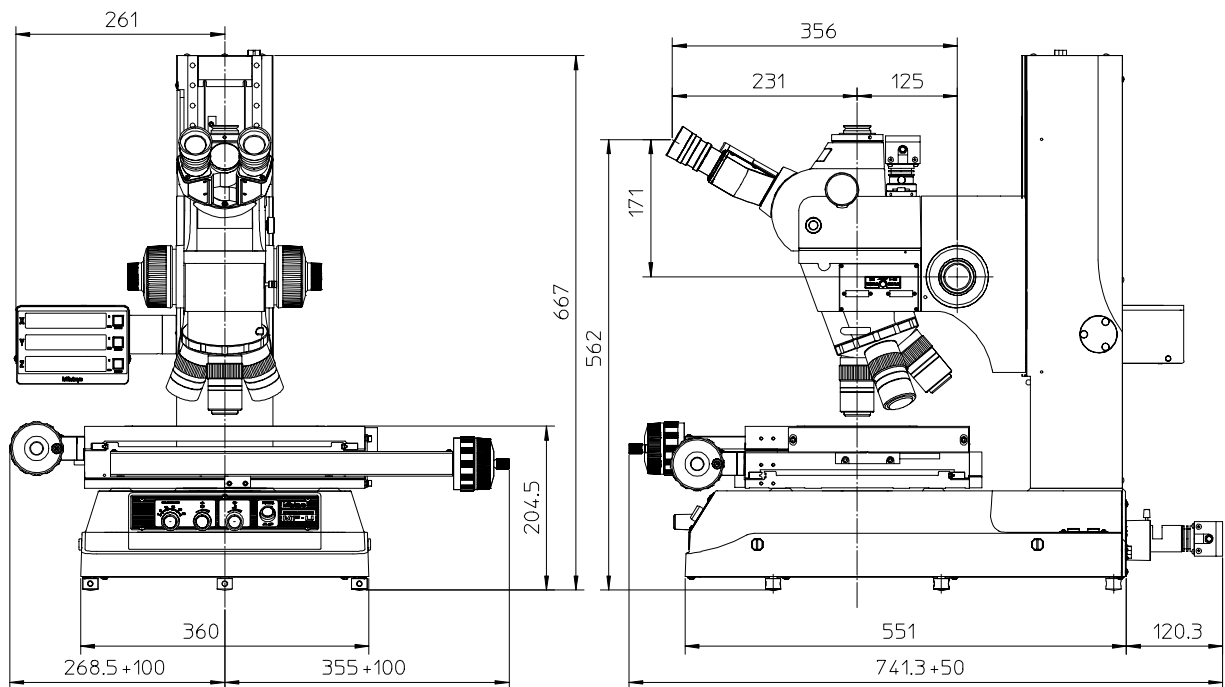

d) MF-U * 2017C

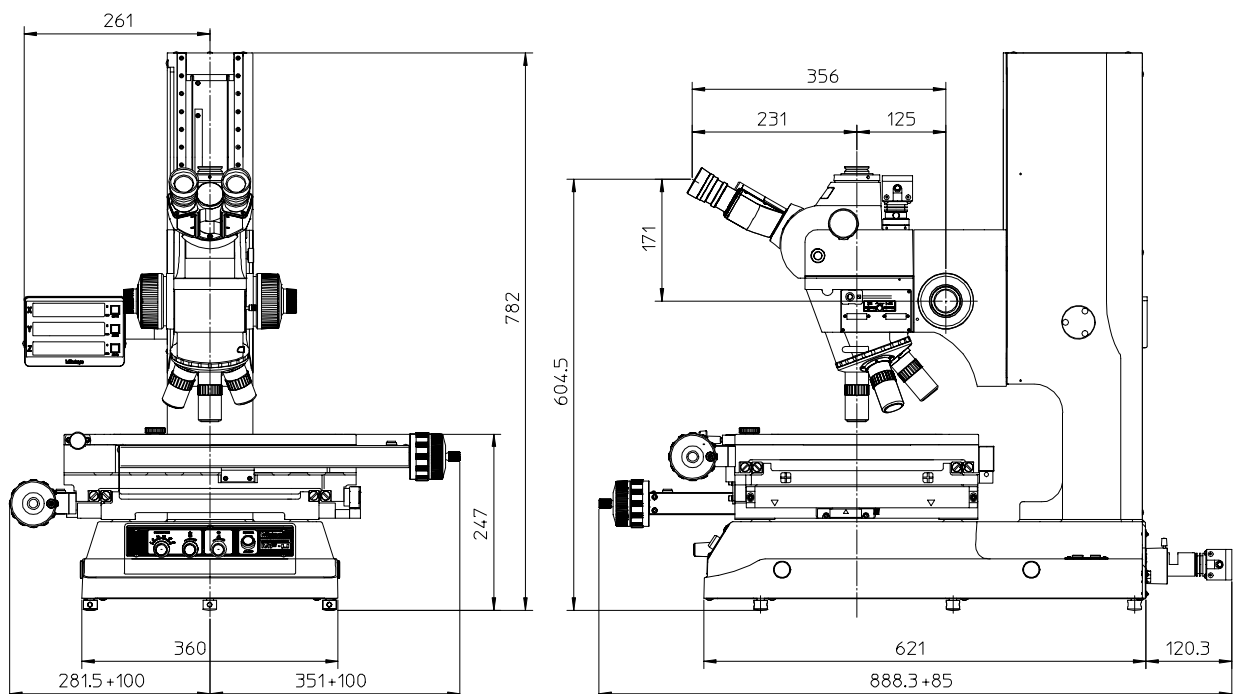

(unit : mm)

e) MF-U * 3017C

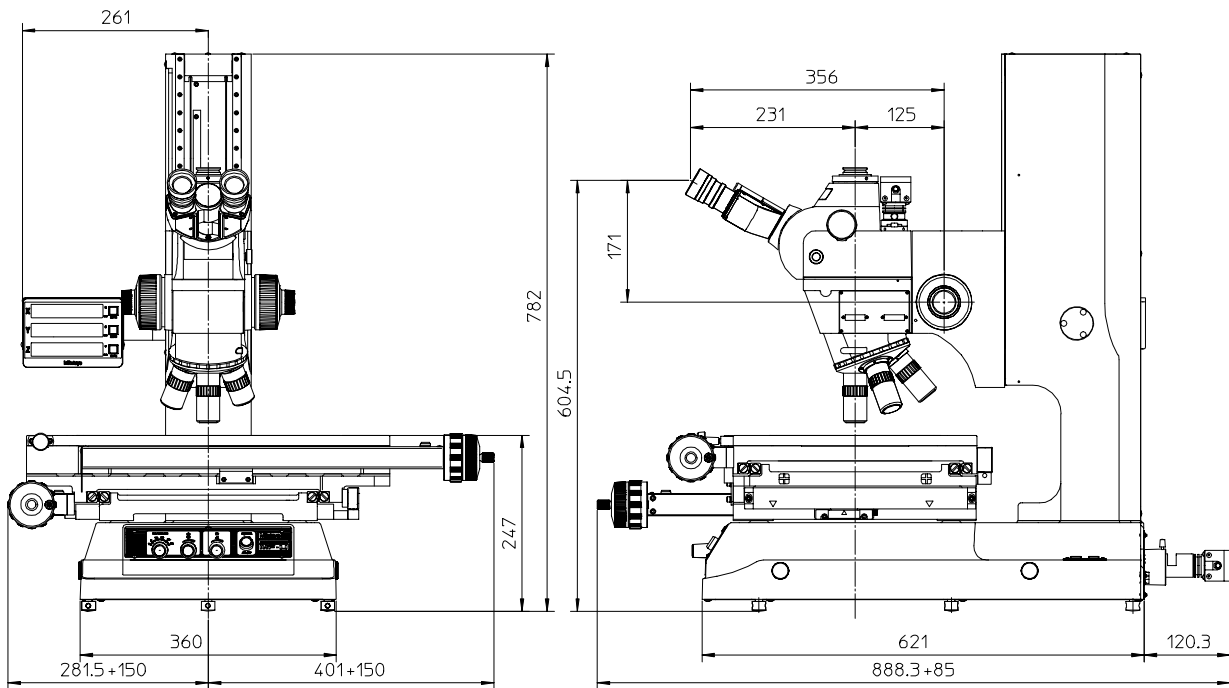

f) MF-U * 4020C

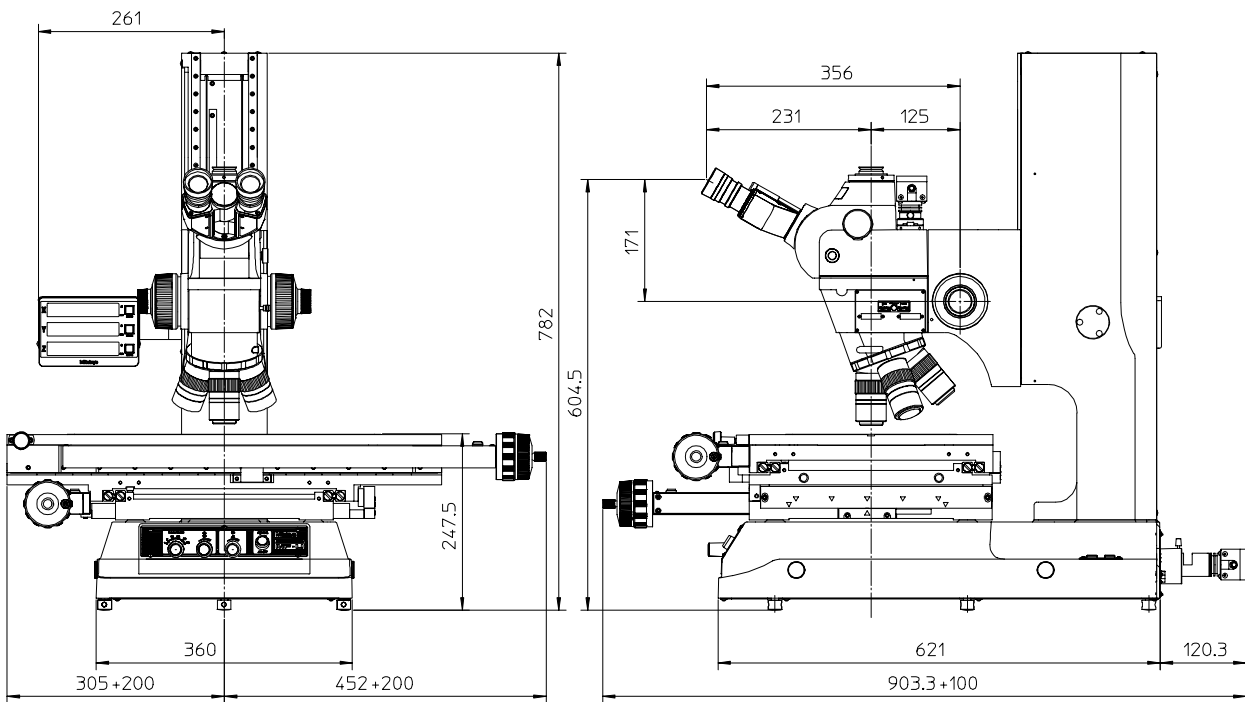

6. Specifications

6.8.2 Control unit

(unit : mm)

a) LED illuminator

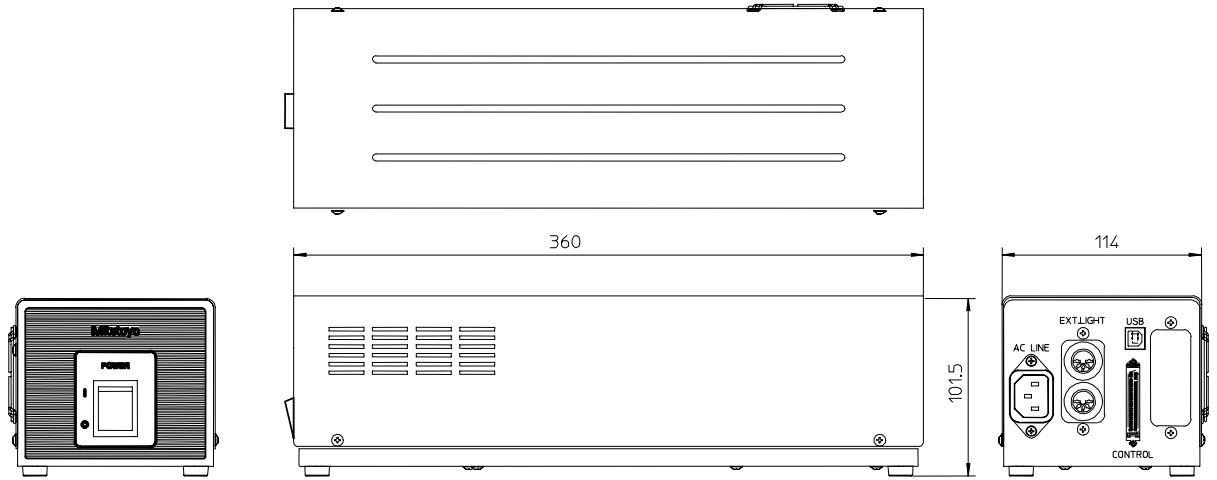

b) Halogen illuminator

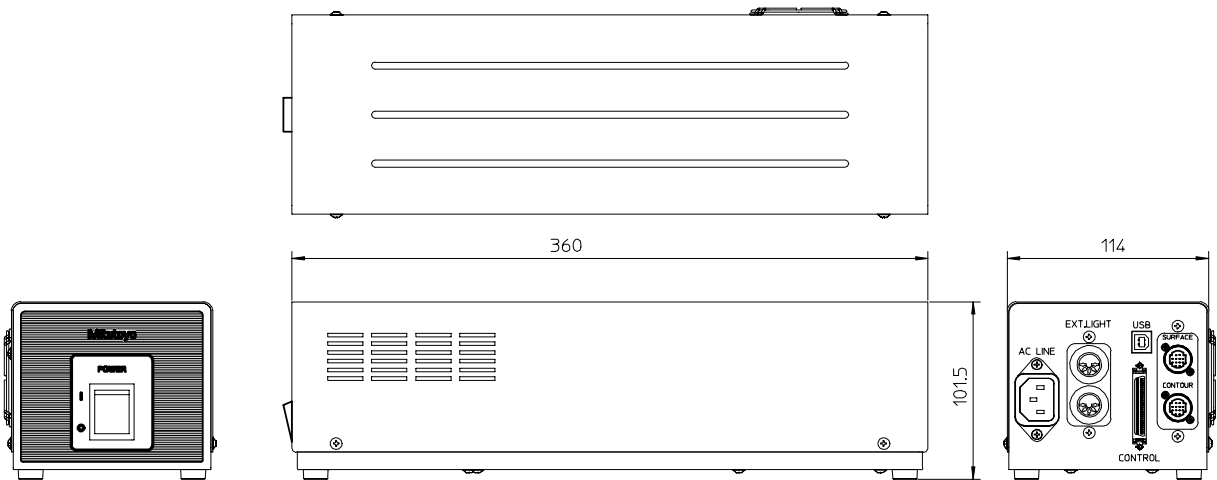

6.8.3 Cross-travel stage

(unit : mm)

a) MF-U * 505C

b) MF-U * 1010C

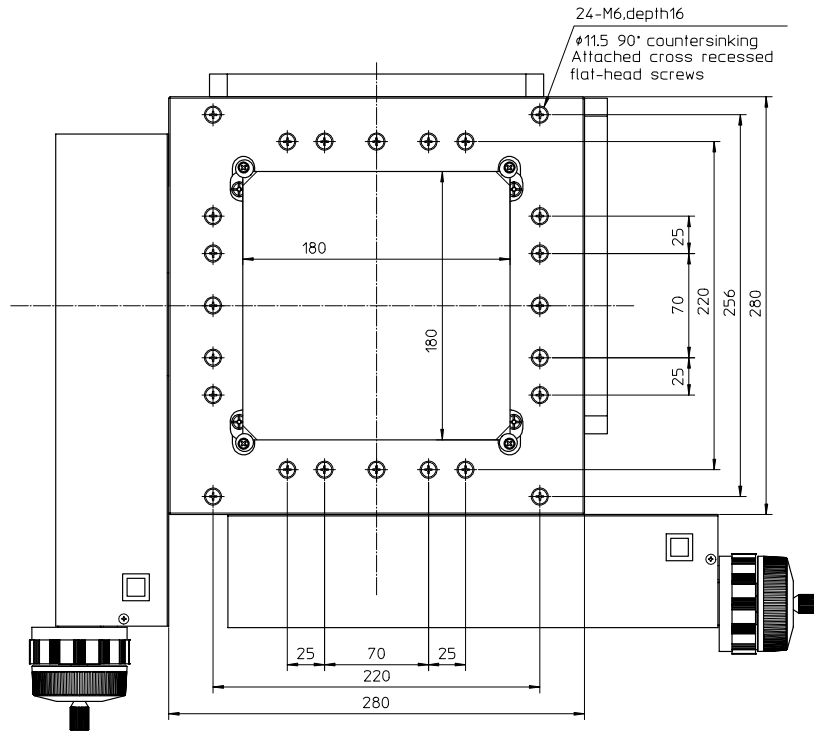

c) MF-U * 2010C

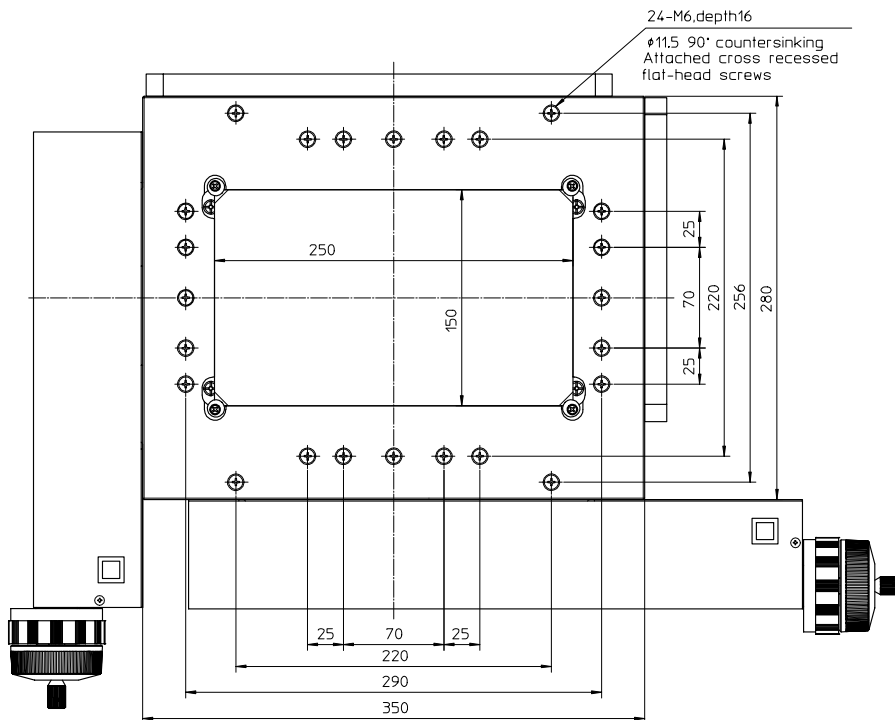

d) MF-U * 2017C

(unit : mm)

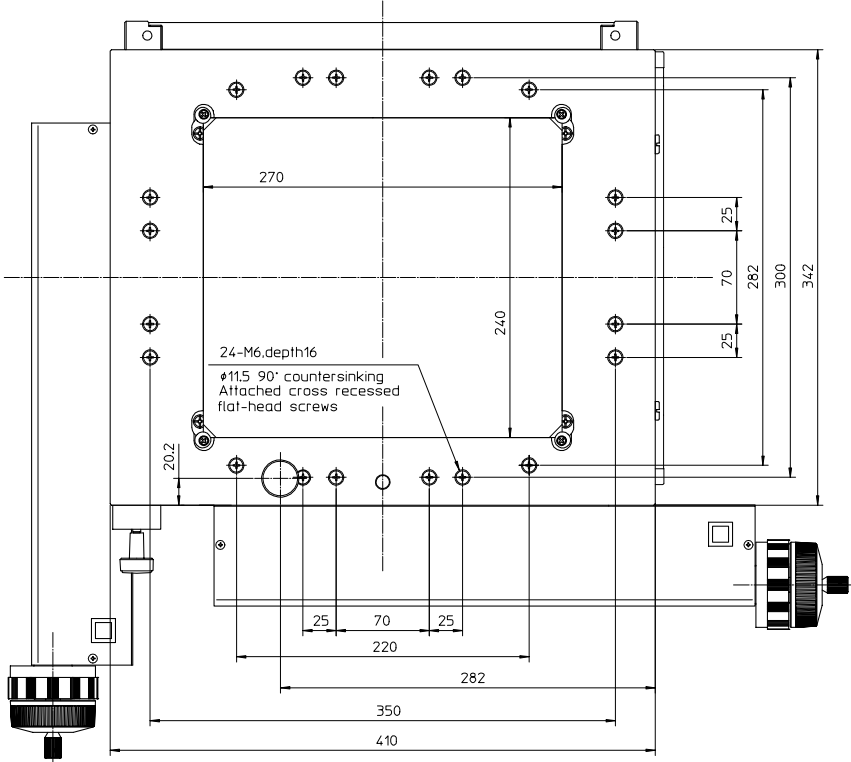

e) MF-U * 3017C

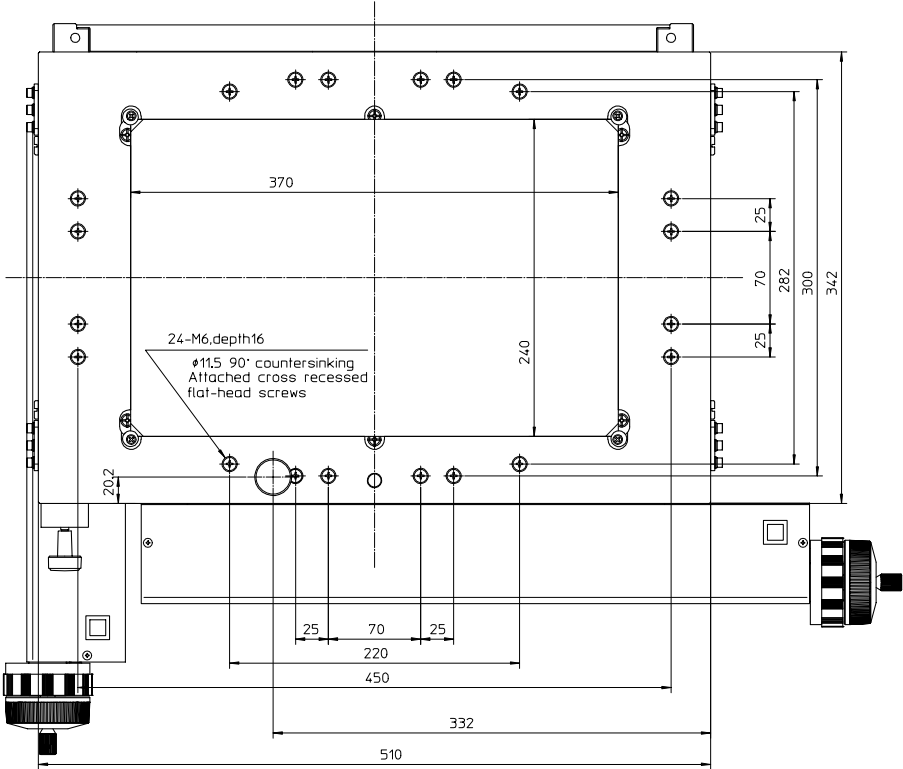

f) MF-U * 4020C

