

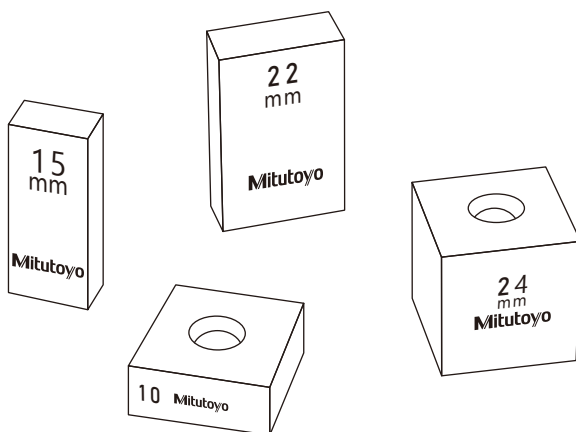

Gauge Blocks/ CERA Blocks



User's Manual

- Instructions for use -

Read this document thoroughly before operating the product. After reading, retain it close at hand for future reference.

This English language version of the document contains the original instructions.

No. 99MAK004B4

Date of publication: January 1, 2023 (1)



■ Product names and model numbers covered in this document

This document is included with the following products.

Product name	Model number
Rectangular Gauge Block set (steel, millimeter units)	BM1-XXX
Rectangular Gauge Block set (ceramic, millimeter units)	BM3-XXX
Square Gauge Block set (steel, millimeter units)	BM4-XXX
Rectangular Gauge Block set (steel, inch units)	BE1-XXX
Rectangular Gauge Block set (ceramic, inch units)	BE3-XXX
Square Gauge Block set (steel, inch units)	BE4-XXX
Square Gauge Block set (ceramic, inch units)	BE6-XXX

■ Notice regarding this document

- Mitutoyo Corporation assumes no responsibilities for any damage to the product, caused by its use not conforming to the procedure described in this document.
- Upon loan or transfer of this product, be sure to attach this document to the product.
- In the event of loss or damage to this document, immediately contact the agent where you purchased the product or a Mitutoyo sales office.
- Read this document thoroughly before operating the product. In particular, be sure to fully understand "Safety Precautions" on page 4 and "Precautions for Use" on page 4.
- The contents of this document are based on information current as of January 2023.
- No part or whole of this document may be transmitted or reproduced by any means without prior written permission of Mitutoyo Corporation.
- Some screen displays in this document may be highlighted, simplified or partially omitted for convenience of explanation. In addition, some of them may differ from actual ones to the extent that no user will misunderstand the functions and operations.
- The corporation, organization and product names that appear in this document are their trademarks or registered trademarks.

© 2018-2023 Mitutoyo Corporation. All rights reserved.

Contents

Contents	i
About This Document	1
Conventions Used in This Document	2
Safety Precautions	4
Precautions for Use	4
Export Control Compliance	6
Notes on Export to European Countries	6
Disposal of Products outside the European Countries	6
Warranty	7
Disclaimer	8
1 Overview	9
2 How to Use Gauge Blocks	11
2.2 Wringing	16
3 Maintenance	19
4 Periodic Calibration/Inspection	21
5 Specifications	23
5.1 Specifications	23
5.2 Related Products	25
6 Appendix	27
SERVICE NETWORK	App-1



About This Document

■ Intended readers and purpose of this document

● Intended readers

This document is intended for those who have a basic knowledge of how to use Gauge Blocks, wringing, characteristics, reference gage applications, etc.

● Purpose



The purpose of this document is to help you understand the basic usage, work procedures, and the various functions of Gauge Blocks/CERA Blocks.

Conventions Used in This Document

■ Safety reminder conventions warning against potential hazards

NOTICE	Indicates a situation which, if not avoided, may result in property damage.
---------------	--

■ Conventions indicating referential information or reference location

IMPORTANT	Indicates information that must be known when using the product.
Tips	Indicates further information and details relevant for the operating methods and procedures that are explained in that section.
	Indicates reference location if there is information that should be referred to in this document or an extraneous User's Manual. Example: For details about XX, see  "2 How to Use Gauge Blocks" on page 11.

■ Other conventions

(): Round brackets	Represent a paraphrase of an immediately preceding phrase or a supplementary explanation.
" ": Double quotation marks	Represent a highlighted phrase. They also indicate an index where information to be referenced is described.
1, 2, 3 1, 2, 3, ...	Indicates the order and the contents of tasks. (1 : indicates main tasks, 1 : indicates detailed tasks)
»	Indicates the action resulted from some operation(s).

■ Example of conventions use

2 How to Use Gauge Blocks

4 Wring the 30 mm Gauge Block and other Gauge Blocks together in order of thickness.

Tips
 When wringing a thin Gauge Block, check the state of the measurement surface of the thin Gauge Block. Do not use abrasives on the optical flat.
 For details about wringing, see "2.2 Wringing" (page 16).

5 Perform thermal stabilization.

6 Use as a reference gage.

Example of comparative measurement



Example of zero-setting for a measuring tool



2 How to Use Gauge Blocks

2 Gently place the optical flat on the measurement surface of the Gauge Block.

IMPORTANT
 Place the optical flat on the measurement surface of the Gauge Block so that the arrow printed on the side of the optical flat points downward.

3 Lightly slide the optical flat.
 » If interference fringes appear: Proceed to step 4.

» If interference fringes do not appear: Burrs exist; proceed to step 2.

Tips
 Interference fringes may not appear if the surfaces were not wiped sufficiently or if paper fibers are present on the surface. In this case, wipe the surfaces again, and then repeat from step 2.

4 Lightly hold down the optical flat.

Indicates an operating procedure to be performed or its outline.

Indicates the referential location.

Indicates specific work procedures.

Indicates supplementary information.

Indicates the action resulted from some operation(s).

Safety Precautions

Read these "Safety Precautions" thoroughly before operating the system to use it properly.

These safety precautions include such information as to prevent an injury to the operator and other persons or damage to property. Be sure to observe the precautions.

NOTICE

Do not exert external forces to this product. Doing so may cause breakage.

Precautions for Use

■ Product applications and handling

● This product is a length reference gage (end standard).

Do not use it for any purposes other than its prescribed usage as a length reference gage.

● This product is precision equipment.

- It must be carefully handled. Be careful not to apply excessive shock or force to any of the parts during storage or use.
- If an excessive impact is applied, the center dimensions or the range of dimension differences, etc., may be affected. Have calibration performed to check the dimensions.
- Before use, use a soft cloth soaked in solvent, etc., to wipe off any dirt or rust-proofing oil. Do not use organic solvents such as thinner or benzene.
- If rusting occurs on the sides of this product, wipe the rust off with a soft cloth. Do not use sandpaper or polishing paper.

■ Operating environment

Only use this product in the following environments.

- Areas free of dirt and dust
- Areas free of vibrations
- Areas in the recommended temperature of 20 °C or so with minimal temperature change

IMPORTANT

When using this product, be sure to perform sufficient thermal stabilization.

- On the surface plate (recommended)

Avoid using the product in the following environments.

- Areas directly subject to drafts of hot air, cool air, or air conditioning

■ Maintenance

After use, wipe dirt off the product with a soft cloth soaked in solvent, etc., and then apply anti-rust oil in a thin layer (for rust prevention). Do not use organic solvents such as thinner or benzene.

Tips

- For Gauge Blocks made of ceramics (CERA Blocks), rustproofing treatment is not necessary.
- Recommended solvent: Normal heptane
- Recommended anti-rust oil: MOLYKOTE SUPERGLISS (Dow Corning Toray Co., Ltd.)

Export Control Compliance

This product falls into the Catch-All-Controlled Goods and/or Catch-All-Controlled Technologies (including Programs) under Category 16 of Appended Table 1 of Export Trade Control Order or under Category 16 of Appended Table of Foreign Exchange Control Order, based on Foreign Exchange and Foreign Trade Act of Japan.

If you intend re-export of the product from a country other than Japan, re-sale of the product in a country other than Japan, or re-providing of the technology (including Programs), you shall observe the regulations of your country.

Also, if an option is added or modified to add a function to this product, this product may fall under the category of List-Control Goods, List-Control Technology (including Programs) under Category 1 - 15 of Appended Table 1 of Export Trade Control Order or under Category 1 - 15 of Appended Table of Foreign Exchange Control Order, based on Foreign Exchange and Foreign Trade Act of Japan. In that case, if you intend re-export of the product from a country other than Japan, re-sale of the product in a country other than Japan, or re-providing of the technology (including Programs), you shall observe the regulations of your country. Please contact Mitutoyo in advance.

Notes on Export to European Countries

When you intend exporting of this product to any of the European countries, it may be required to provide User's Manual(s) in English and Declaration of Conformity in English (in some cases, the official language of the country to be exported). For detailed information, please contact Mitutoyo in advance.

Disposal of Products outside the European Countries

Please follow the official instruction in each community and country.

Warranty

This product has been manufactured under strict quality management, but should it develop problems within one year of the date of purchase in normal use, repair shall be performed free of charge. Please contact the agent where you purchased the product or Mitutoyo sales representative ( "SERVICE NETWORK" on page App-1).

If this product fails or is damaged for any of the following reasons, it will be subject to a repair charge, even if it is still under warranty.

- Failure or damage owing to fair wear and tear
- Failure or damage owing to inappropriate handling, maintenance or repair, or to unauthorized modification
- Failure or damage owing to transport, dropping, or relocation of the product after purchase
- Failure or damage owing to fire, salt, gas, abnormal voltage, lightning surge, or natural disaster
- Failure or damage owing to use in combination with hardware or software other than those designated or permitted by Mitutoyo
- Failure or damage owing to use in ultra-hazardous activities

This warranty is effective only where the product is properly installed and operated in conformance with the instructions in this document within the original country of the installation.

EXCEPT AS SPECIFIED IN THIS WARRANTY, ALL EXPRESS OR IMPLIED CONDITIONS, REPRESENTATIONS, AND WARRANTIES OF ANY NATURE WHATSOEVER INCLUDING, WITHOUT LIMITATION, ANY IMPLIED WARRANTY OF MERCHANTABILITY, FITNESS FOR A PARTICULAR PURPOSE, NONINFRINGEMENT OR WARRANTY ARISING FROM A COURSE OF DEALING, USAGE, OR TRADE PRACTICE, ARE HEREBY EXCLUDED TO THE MAXIMUM EXTENT ALLOWED BY APPLICABLE LAW.

You assume responsibility for all results due to the selection of this product to achieve your intended results.

Disclaimer

IN NO EVENT WILL MITUTOYO, ITS AFFILIATED AND RELATED COMPANIES AND SUPPLIERS BE LIABLE FOR ANY LOST REVENUE, PROFIT, OR DATA, OR FOR SPECIAL, DIRECT, INDIRECT, CONSEQUENTIAL, INCIDENTAL, OR PUNITIVE DAMAGES HOWEVER CAUSED AND REGARDLESS OF THE THEORY OF LIABILITY ARISING OUT OF THE USE OF OR INABILITY TO USE THIS PRODUCT EVEN IF MITUTOYO OR ITS AFFILIATED AND RELATED COMPANIES AND/OR SUPPLIERS HAVE BEEN ADVISED OF THE POSSIBILITY OF SUCH DAMAGES.

If, notwithstanding the foregoing, Mitutoyo is found to be liable to you for any damage or loss which arises out of or is in any way connected with use of this product by you, in no event shall Mitutoyo's and/or its affiliated and related companies' and suppliers' liability to you, whether in contract, tort (including negligence), or otherwise, exceed the price paid by you for the product only.

The foregoing limitations shall apply even if the above-stated warranty fails of its essential purpose.

BECAUSE SOME COUNTRIES, STATES OR JURISDICTIONS DO NOT ALLOW THE EXCLUSION OR THE LIMITATION OF LIABILITY FOR CONSEQUENTIAL OR INCIDENTAL DAMAGES, IN SUCH COUNTRIES, STATES OR JURISDICTIONS, MITUTOYO'S LIABILITY SHALL BE LIMITED TO THE EXTENT PERMITTED BY LAW.

1 Overview

■ Overview of Gauge Blocks

This product is a "length reference gage (end standard)" used as a reference dimension, for the calibration of various measuring tools, etc. This product has two parallel, flat measurement surfaces, and it has been accurately machined so that the distance between the two surfaces should be extremely close to the nominal size. Additionally, by setting together multiple Gauge Blocks firmly (called wringing), you can obtain a very precise custom dimension that is the sum of the dimensions of the wrung Gauge Blocks.

Steel and ceramics, which have high hardness and offer superior wear resistance, are used as the material. The Gauge Blocks are broadly classified as rectangular or square, based on the shape of their cross sections.

Rectangular Gauge Block

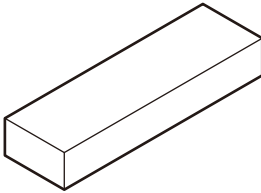

Square Gauge Block

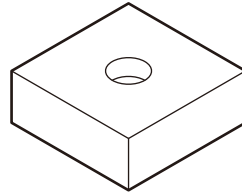

Tips

- Gauge Blocks made of ceramics are referred to as CERA Blocks.
- Rectangular Gauge Blocks of standard size with a nominal size of at least 125 mm have "coupling holes".

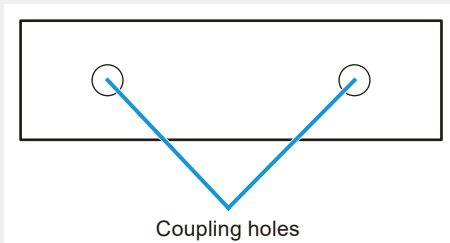

■ Grades of Gauge Blocks

Grades that indicate the dimensional accuracy (for example, Grade K, Grade 0, Grade 1, and Grade 2 in the JIS standard) are set for the Gauge Blocks. Select an appropriate grade according to the accuracy required for your application.

For details about the dimensional accuracy, see  "Grade and Application" and "ACCURACY SPECIFICATIONS" in "MEASURING INSTRUMENTS CATALOG / Gauge Blocks" or the relevant standards (ISO/JIS/DIN/BS/ASME) in each country.

Grades and applications (from MEASURING INSTRUMENTS CATALOG)

Application		Grade
Reference use	Checking the accuracy of Gauge Blocks for calibration. For academic research	K
Calibration use	Checking the accuracy of Gauge Blocks for workshop/inspection. Checking the accuracy of measuring tools	K or 0
Inspection use	Checking the accuracy of gages. Calibrating measuring tools	0 or 1
	Inspecting mechanical parts, tools, etc.	1 or 2
Workshop use	Manufacturing gages. Calibrating measuring tools	1 or 2
	Mounting tools and cutters	2

■ Contents of a Gauge Block set

A set is composed of Gauge Blocks with various nominal sizes. Wring Gauge Blocks together to obtain the desired dimension.

Examples of standard sets:

BM1-112 (112-piece set)

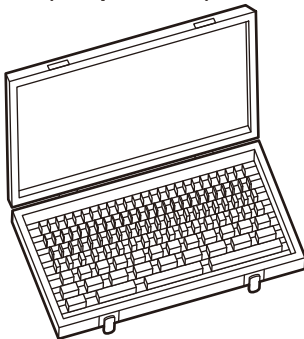

BM1-8R (8-piece set)

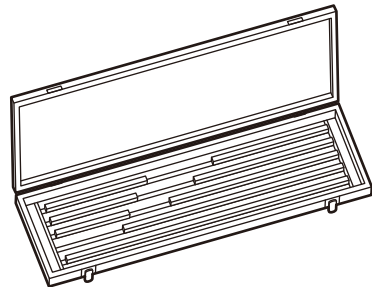

2 How to Use Gauge Blocks

This section describes an example of typical usage (assembling of a reference gage with a desired length) and explains the wringing process.

2.1 Example of Typical Usage (Assembling a Reference Gage with a Desired Length)

Assemble a reference gage with a desired length by wringing Gauge Blocks together.

The assembled reference gage can be used for the zero setting for measuring tools and for comparative measurement.

As an example, this procedure explains the assembly of a 37.785 mm length reference gage.

■ Precautions about the assembly

- Use as few Gauge Blocks as possible for the assembly.
- Select thick Gauge Blocks as much as possible.
- Begin by selecting a Gauge Block where the last digit of the target dimensions matches the last digit of the nominal size.

NOTICE

If you select the same Gauge Blocks each time you assemble them, those Gauge Blocks will wear down faster than the other Gauge Blocks.

Make a different combination each time so that Gauge Blocks will wear down at the same rate.

The following shows an example assembly.

Gauge Block to use	Selection order
1.005	1
1.08	2
1.7	3
4	4
30	5
<hr/>	
37.785 mm	

■ Preparation

Necessary Gauge Blocks and tools

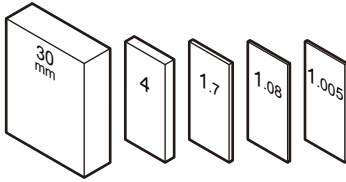

Gauge Blocks
30 mm/4 mm/1.7 mm/1.08 mm/1.005 mm

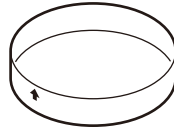

Optical flat
(Option accessory)

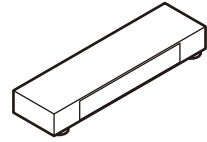

Ceraston
(Option accessory)

■ Assembly

NOTICE

To prevent changes in the surface condition caused by temperature and rusting due to exposure to sweat, it is recommended that you wear gloves for precision work.

Before assembling, all the Gauge Blocks to be wrung must be checked for burrs, and any burrs must be removed. In the case of new Gauge Blocks, it is not necessary to check for or remove burrs.

1 Checking for burrs on the measurement surfaces with an optical flat

Tips

An optical flat is a product for performing a simple flatness check.

- 1 Wipe the measurement surfaces of the Gauge Block and both surfaces of the optical flat with lens cleaning paper soaked in solvent (such as normal heptane), and then wipe the surfaces dry with a dry portion of the paper.

Tips

For wiping, use lens cleaning paper or other material which does not leave paper fibers.

2 How to Use Gauge Blocks

- 2 Gently place the optical flat on the measurement surface of the Gauge Block.

IMPORTANT

Place the optical flat on the measurement surface of the Gauge Block so that the arrow printed on the side of the optical flat points downward.

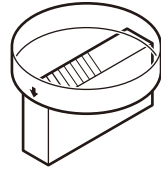

- 3 Lightly slide the optical flat.
 - » If interference fringes appear: Proceed to step 4.

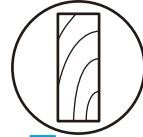

- » If interference fringes do not appear: Burrs exist; proceed to step 2.

Tips

Interference fringes may not appear if the surfaces were not wiped sufficiently or if paper fibers are present on the surface. In this case, wipe the surfaces again, and then repeat from step 2.

- 4 Lightly hold down the optical flat.
 - » If interference fringes do not appear: No burrs exist; proceed to step 3.
 - » If interference fringes partially appear: Burrs exist; proceed to step 2.

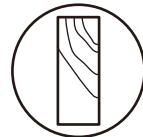
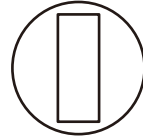

Tips

If interference fringes partially appear, slide the optical flat slightly. If the interference fringes move with the optical flat, it means that there are burrs on the optical flat, and not on the Gauge Block. Use a new optical flat.

2 Removing burrs from the measurement surface with a Ceraston (part No. 601644 or No. 601645)

- 1 Wipe the measurement surface of the Gauge Block and the surface of the Ceraston with lens cleaning paper soaked in solvent (such as normal heptane), and then wipe the surfaces dry with a dry portion of the paper.

Tips

For wiping, use lens cleaning paper or other material which does not leave paper fibers.

- 2 Place the measurement surface of the Gauge Block with burrs facing towards the Ceraston.
- 3 While holding the Gauge Block by its sides with your thumb and middle finger, lightly push the upper surface of the Gauge Block with your index finger to give a back and forth motion to the Gauge Block 10 times on the Ceraston.

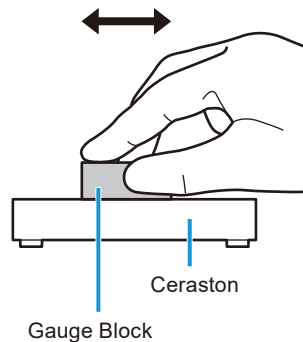

Tips

- If the Gauge Block is too thin to hold (a nominal size of 3 mm or less, for example), using an eraser or other rubbery object to hold down the Gauge Block may help apply the force uniformly, as shown in the figure on the right.
- The Gauge Block will smoothly slide on the Ceraston as long as there are burrs. The Gauge Block will start to stick to the Ceraston as burrs are removed.

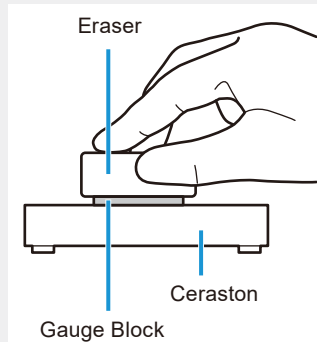

- 3 Repeat steps 1 and 2 to check and remove burrs on all the Gauge Blocks to be wrung.

Tips

If burrs cannot be removed even by repeating steps 1 and 2, the Gauge Block cannot be used as a reference gage. Purchase a new Gauge Block with the same nominal size as a replacement.

4 Wring the 30 mm Gauge Block and other Gauge Blocks together in order of thickness.

Tips

When wringing a thin Gauge Block, check the state of the measurement surface of the thin Gauge Block by placing on the optical flat.

For details about wringing, see  "2.2 Wringing" (page 16).

5 Perform thermal stabilization.

6 Use as a reference gage.

Example of comparative measurement

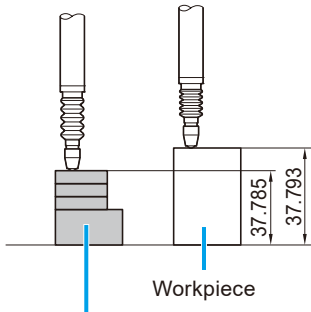

Reference gage (wring Gauge Blocks)

Example of zero-setting for a measuring tool

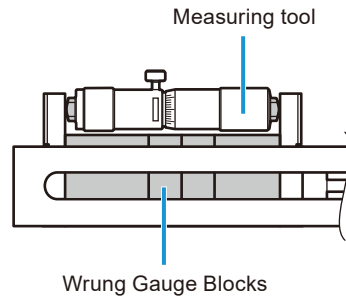

Disassembly

1 Disengaging the wringing

- 1 Rotate the wrung Gauge Blocks until they form a cross shape.

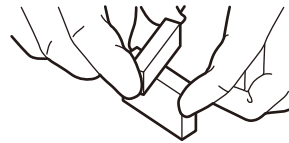

- 2 Slide the Gauge Blocks to detach them.

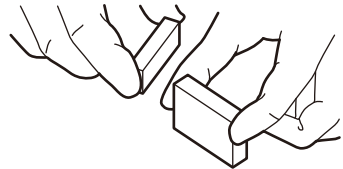

2 Wipe any dirt off the Gauge Blocks.

Tips

For details about cleaning, see  "■ Cleaning" (page 19).

2.2 Wringing

The process of firmly assembling Gauge Blocks together is called "wringing". A steel Gauge Block and a CERA Block can also be wrung together.

NOTICE

When handling Gauge Blocks and accessories, wear gloves for precision work. If handled with bare hands, the resulting heat conduction can alter the block's dimensions. For steel Gauge Blocks, oils and sweat can cause rusting to occur.

- 1 Wipe surfaces for wringing with lens cleaning paper soaked in solvent (such as normal heptane), and then wipe the surfaces dry with a dry portion of the paper.**

NOTICE

If small pieces of dirt or grease are left on surfaces for wringing, it is added to the dimension of wrung Gauge Blocks, or the Gauge Blocks may be scratched.

Tips

For wiping, use lens cleaning paper or other material which does not leave paper fibers.

- 2 Slightly spread Vaseline or grease onto the surfaces for wringing before wiping.**

Tips

Wipe until the oil layer is almost completely gone.



- 3 Wring the Gauge Blocks together.**

The following three situations are possible:

- For a thick Gauge Block and a thick Gauge Block
- For a thick Gauge Block and a thin Gauge Block
- For a thin Gauge Block and a thin Gauge Block

Tips

A Gauge Block with a nominal size of less than 3 mm is considered a thin Gauge Block.

2 How to Use Gauge Blocks

For a thick Gauge Block and a thick Gauge Block

- 1 Cross the Gauge Blocks at the center of each measurement surface at 90° (45° for Square Gauge Blocks).



- 2 While slightly applying force, rotate one Gauge Block 90° (45° for Square Gauge Blocks) until both measurement surfaces are aligned with each other.

Tips

It will feel like the blocks are sticking together while you are sliding the blocks.

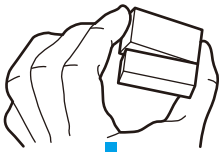

- 3 Align the measurement surfaces with each other.

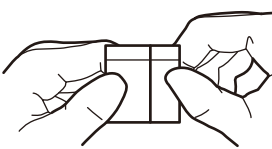

Proceed to step **5**.

For a thick Gauge Block and a thin Gauge Block

- 1 Place one end of the thin Gauge Block on top of one end of the thick Gauge Block (to prevent thin Gauge Blocks from bending).

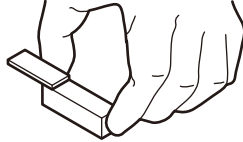

- 2 Slide the thin Gauge Block while pressing the entire overlapped area until both measurement surfaces are aligned with each other.

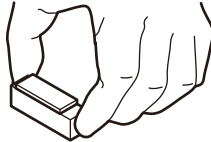



Proceed to step **4**.

For a thin Gauge Block and a thin Gauge Block

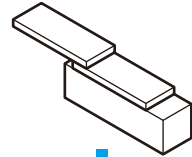

- 3 Wrap another thin Gauge Block on top of the thin Gauge Block wrung in steps 1 through 2.



- 4 Detach the thick Gauge Block wrung in steps 1 through 2. For details, see  "Disassembly" (page 15).



2 How to Use Gauge Blocks

4 If a thin Gauge Block is wrung, the surface of the Gauge Block must be checked with the optical flat (flatness check).

- » If interference fringes do not appear: The wrung Gauge Block is not bent. → Step **5**
- » If interference fringes appear: The wrung Gauge Block is bent. → Redo wringing from the beginning.

5 Wipe the measurement surfaces, and then place the wrung Gauge Blocks on the surface plate (for thermal stabilization).

NOTICE

Generally, CERA Blocks have the advantage of a slow response to temperature changes because of their low thermal conductivity. However, if they are used in an environment with drastic temperature changes, caution must be taken because of their slow recovery speed from an expanded or contracted state.

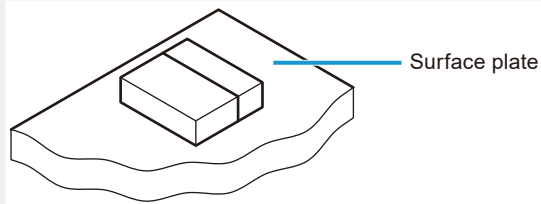

Tips

The following figure shows an example of changes in dimension when a 100 mm steel Gauge Block is handled with bare hands.

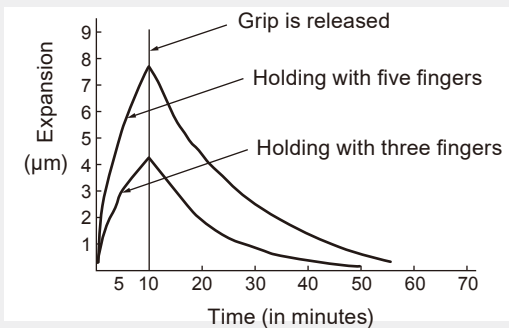

3 Maintenance

This section explains the regular inspection and cleaning of this product.

In order to use this product with sufficient performance safely and for a long period, follow the items below to perform inspection and cleaning.

■ Regular inspection

Check the appearance of the Gauge Block for dirt/dust, scratches, and wear.

To check for wear on the surfaces for wringing, use a tool such as an optical flat to check for interference fringes.

If there are any burrs or nicks, use a Ceraston* to remove them.

To maintain the quality of your Gauge Blocks, we recommend periodic calibration/inspection services provided by Mitutoyo.

* Ceraston: Part No. 601644 or No. 601645

■ Cleaning

After use, wipe dirt off the Gauge Block with a soft cloth soaked in solvent, etc., and then apply anti-rust oil in a thin layer before housing and storing it in a safe place (for rust prevention).

Do not use organic solvents such as thinner or benzene.

Tips

- Recommended solvent: Normal heptane
- Recommended anti-rust oil: MOLYKOTE SUPERGLISS (Dow Corning Toray Co., Ltd.)
- Placing evaporative anti-rust paper into the storage case provides more effective storage.
- For CERA Blocks, rustproofing treatment is not necessary.

MEMO

4 Periodic Calibration/Inspection

To maintain the quality of your Gauge Blocks, we recommend periodic calibration/inspection services provided by Mitutoyo.

Reference: Frequency of calibration/inspection

Application	Cycle	Grade (for reference)
Reference use	1–2 years	K
Calibration use	2 years	K or 0
Inspection use	2 years	0 or 1
Workshop use	6 months–2 years	1 or 2

NOTICE

Send your Gauge Blocks, appropriately packed with shock-absorbing material, to Mitutoyo for calibration/inspection. If the Gauge Blocks are not appropriately packed, the accuracy or appearance of the Gauge Blocks may be impaired during transport.

MEMO

5 Specifications

5.1 Specifications

■ Cross-sectional diagram and dimensions

● Rectangular Gauge Block

Steel: Nominal size L 0.1 mm–100 mm, 0.004 in–4 in

Ceramics: Nominal size L 0.5 mm–100 mm, 0.03125 in–4 in

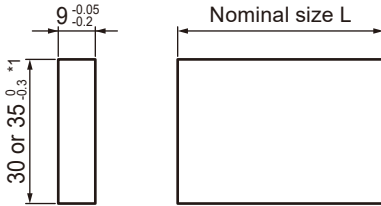

*1 Nominal size L is 10 mm or less: 30 mm
Nominal size L is more than 10 mm: 35 mm

Steel: Nominal size L 125 mm–1000 mm, 5 in–20 in

Ceramics: Nominal size L 125 mm–500 mm, 5 in–20 in

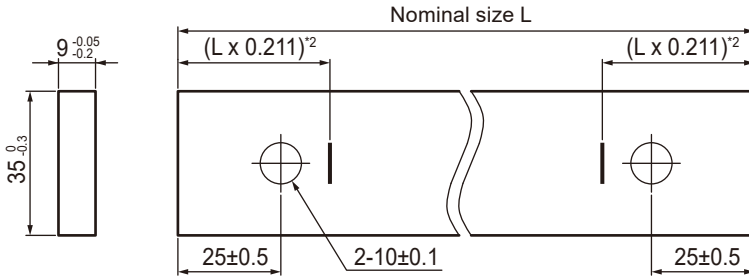

*2 The dimension from the end face to the airy point

● Square Gauge Block

Steel: Nominal size L 0.5 mm–4.5 mm, 0.01 in–0.19 in

Ceramics: Nominal size L 0.05 in–0.19 in

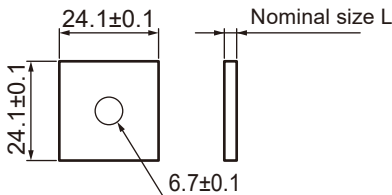

5 Specifications

Steel: Nominal size L 5 mm–100 mm, 0.2 in–4 in

Ceramics: Nominal size L 0.2 in–4 in

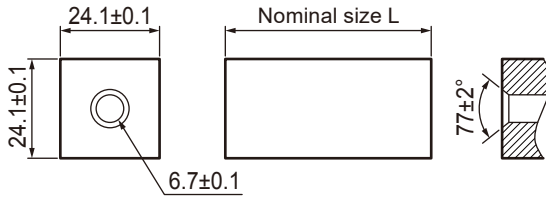

Steel: Nominal size L 125 mm–500 mm, 5 in–20 in

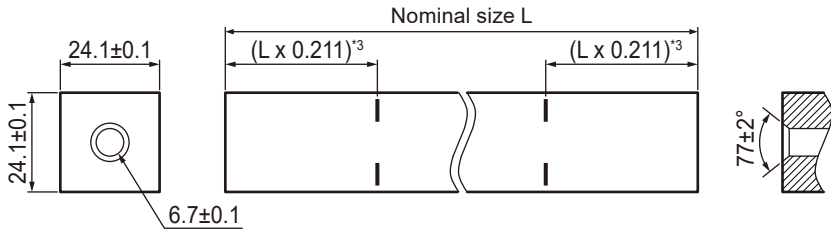

*3 The dimension from the end face to the airy point

Material and properties

Application		Material	CERA Block (Zirconia)	Steel	Tungsten carbide	Zero CERA Block (Low thermal-ex- pansion ceramics)
Hardness	HV		1350	800	1650	826
Thermal expansion coefficient	$10^{-6}/K$		9.3 ± 0.5	10.8 ± 0.5	5.5 ± 1.0	0 ± 0.02
Flexural strength (three points)	MPa		1270	1960	1960	210
Fracture toughness (KIC)	$MPa \cdot m^{1/2}$		7	120	12	1.2
Young's modulus ($\times 10^4$)	MPa		20.6	20.6	61.8	130
Poisson's ratio			0.3	0.3	0.2	0.3
Specific gravity			6.0	7.8	14.8	2.5
Thermal conductivity	W/m·k		2.9	54.4	79.5	3.7

5.2 Related Products

■ Gauge Blocks with thermal expansion coefficients (steel, ceramic)

Gauge Blocks with highly accurate thermal expansion coefficients.
Provided in nominal sizes (100 mm–500 mm) of Rectangular Gauge Blocks.

■ Low thermal-expansion ceramic Gauge Blocks (Zero CERA Blocks)

Gauge Blocks that have extremely small thermal expansion coefficients.
Provided in nominal sizes (30 mm–1000 mm) of Rectangular Gauge Blocks.

■ Gauge Block Maintenance set (Code No. 516-650E)

A tool set necessary for burr removal and wringing.
Accessories may also be purchased individually.

Set contents	Part No.
Ceraston with both sides finished by lapping (100 mm × 25 mm × 12 mm)	601645
Optical flat OF-45B (ø45, thickness: 12 mm, flatness: 0.2 μm)	158-117
Tweezers	600004
Brush (blower brush for photographs)	600005
Cleaning paper (lens cleaning paper, 82 mm × 304 mm, 500 pieces)	600006
Mat (B4 size, artificial deerskin)	600007
Cleaning solution container (plastic, 100 ml)	600008
Gloves for inspection	600009

Tips

For details, see  "MEASURING INSTRUMENTS CATALOG".

MEMO

6 Appendix

■ About the terms used in inspection reports

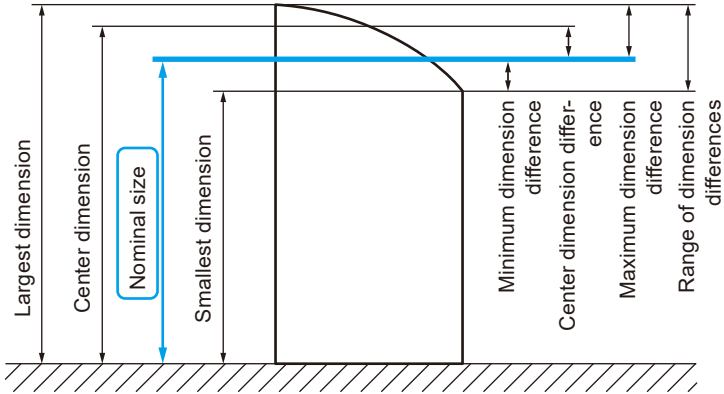

Tips

In inspection, dimensions are measured at five points: the center and the four inner corners (1.5 mm inward from the sides) of the measurement surface of the Gauge Block.

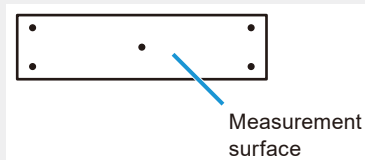

6 Appendix

Term	Explanation
Center dimension difference	Difference between the actual dimension and the nominal size at the center.
Maximum dimension difference	Difference between the largest dimension among the five measurement points and the nominal size. The calibration-result report and inspection report do not indicate which of the five measurement points was the largest.
Minimum dimension difference	Difference between the smallest dimension among the five measurement points and the nominal size. The calibration-result report and inspection report do not indicate which of the five measurement points was the smallest.
Range of dimension differences	Difference between the largest dimension and the smallest dimension.
Measurement uncertainty (standard uncertainty)	Expressed by the standard deviation (deviation between individual measured values and the average of the group) of the variations of the measurement results.
Expanded measurement uncertainty	The standard deviation is expressed by " σ " (sigma). The standard uncertainty is expressed by 1σ , but the expanded measurement uncertainty is expressed by the value obtained by multiplying σ by a coefficient. Mitutoyo has adopted 2σ (a confidence level of 95 %). This is indicated in inspection reports as "coverage factor $k=2$ ". For example, if an inspection report contains "Expanded measurement uncertainty: $0.06 \mu\text{m}$ Coverage factor ($k=2$)", this can be read as "with a probability of 95 %, the measured values in the inspection report fall within the range of $\pm 0.06 \mu\text{m}$. (The remaining 5 % may be outside the range.)".
Light-wave interferometry	A method that directly obtains the length of a Gauge Block by using light wavelengths based on the definition of length. The "center dimension difference" of K-grade products can be obtained with the light-wave interferometry.
Comparative measurement	A method that obtains the dimensions through comparison with a Gauge Block for calibration (reference Gauge Block) whose length is known.

SERVICE NETWORK

*As of July 2022

Europe

Mitutoyo Europe GmbH

Borsigstrasse 8-10, 41469 Neuss, GERMANY
TEL: 49 (0)2137 102-0 FAX: 49 (0)2137 102-351

Mitutoyo CTL Germany GmbH

Von-Gunzert-Strasse 17, 78727 Oberndorf, GERMANY
TEL: 49 (0)7423 8776-0 FAX: 49 (0)7423 8776-99

KOMEG Industrielle Messtechnik GmbH

Zum Wasserwerk 3, 66333 Völklingen, GERMANY
TEL: 49 (0)6898 91110 FAX: 49 (0)6898 911100

Germany

Mitutoyo Deutschland GmbH

Borsigstrasse 8-10, 41469 Neuss, GERMANY
TEL: 49 (0)2137 102-0 FAX: 49 (0)2137 86 85

M³ Solution Center Hamburg

Tempowerkring 9-im HIT-Technologiepark 21079
Hamburg, GERMANY
TEL: 49 (0)40 791894-0 FAX: 49 (0)40 791894-50

M³ Solution Center Berlin

Ernst-Lau-Straße 6, 12489 Berlin, GERMANY
TEL: 49(0)30 2611 267 FAX: 49 30 67988729

M³ Solution Center Eisenach

Neue Wiese 4, 99817 Eisenach, GERMANY
TEL: 49 (0)3691 88909-0 FAX: 49 (0)3691 88909-9

M³ Solution Center Ingolstadt

Marie-Curie-Strasse 1A, 85055 Ingolstadt, GERMANY
TEL: 49 (0)841 954920 FAX: 49 (0)841 9549250

M³ Solution Center Leonberg

Am Längenbühl 3, 71229 Leonberg, GERMANY
TEL: 49 (0)7152 6080-0 FAX: 49 (0)7152 608060

Mitutoyo-Messgeräte Leonberg GmbH

Heidenheimer Strasse 14, 71229 Leonberg, GERMANY
TEL: 49 (0)7152 9237-0 FAX: 49 (0)7152 9237-29

U.K.

Mitutoyo (UK) Ltd. HQ

Joule Road, West Point Business Park, Andover,
Hampshire SP10 3UX, UNITED KINGDOM
TEL: 44 (0)1264 353123 FAX: 44 (0)1264 354883

Coventry M³ Solution Centre

Unit6, Banner Park, Wickmans Drive, Coventry,
West Midlands CV4 9XA, UNITED KINGDOM
TEL: 44 (0)2476 426300

Halifax M³ Solution Centre

Lowfields Business Park, Navigation Close, Elland,
West Yorkshire HX5 9HB, UNITED KINGDOM
TEL: 44 (0)1422 375566

East Kilbride M³ Solution Centre

The Bairds Building, Rankine Avenue, Scottish
Enterprise Technology Park, East Kilbride G75
0QF, UNITED KINGDOM
TEL: 44 (0)1355 581170

France

Mitutoyo France

Paris Nord 2-123 rue de la Belle Etoile, BP 59267
ROISSY EN FRANCE 95957 ROISSY CDG
CEDEX, FRANCE
TEL: 33 (0)149 38 35 00

M³ Solution Center LYON

Parc Mail 523, cours du 3ème millénaire, 69791
Saint-Priest, FRANCE
TEL: 33 (0)149 38 35 70

M³ Solution Center STRASBOURG

Parc de la porte Sud, Rue du pont du péage,
67118 Geispolsheim, FRANCE
TEL: 33 (0)149 38 35 80

M³ Solution Center CLUSES

Espace Scionzier 480 Avenue des Lacs, 74950
Scionzier, FRANCE
TEL: 33 (0)1 49 38 35 90

M³ Solution Center TOULOUSE

Aeroparc Saint Martin Cellule B08 ZAC de Saint Martin
du Touch 12 rue de Caulet, 31300 Toulouse, FRANCE
TEL: 33 (0)1 49 38 42 90

M³ Solution Center RENNES

2, rue Claude Chappe, PA le Vallon - ZAC Mivoie,
35230 Noyal-Châtillon-sur-Seiche, FRANCE
TEL: 33 (0)1 49 38 42 10

Italy

Mitutoyo Italiana S.r.l.

Corso Europa, 7 - 20045 Lainate (MI), ITALY
TEL: 39 02 935781 FAX: 39 02 93578255

M³ Solution Center BOLOGNA

Via dei Carpini1/A - 40011 Anzola Emilia (BO), ITALY
TEL: 39 02 93578215 FAX: 39 02 93578255

M³ Solution Center CHIETI

Contrada Santa Calcagna - 66020 Rocca S. Giovanni (CH), ITALY
TEL: 39 02 93578280 FAX: 39 02 93578255

M³ Solution Center PADOVA

Via G. Galilei 21/F - 35035 Mestrino (PD), ITALY
TEL: 39 02 93578268 FAX: 39 02 93578255

Netherlands

Mitutoyo Nederland B.V.

Koningsschot 41, 3905 PR Veenendaal,
THE NETHERLANDS
TEL: 31(0)318-534911

Mitutoyo Nederland B.V. / M³ Solution Center Enschede

Institutenweg 50, 7521 PK Enschede,
THE NETHERLANDS
TEL: 31(0)318-534911

Mitutoyo Nederland B.V. / M³ Solution Center Eindhoven

De Run 1115, 5503 LB Veldhoven,
THE NETHERLANDS
TEL: 31(0)318-534911

Mitutoyo Research Center Europe B.V.

De Rijn 18, 5684 PJ Best, THE
NETHERLANDS
TEL:31(0)499-320200 FAX:31(0)499-320299

Belgium

Mitutoyo Belgium N.V. / M³ Solution Center Melsele

Schaarbeekstraat 20, B-9120 Melsele,
BELGIUM
TEL: 32 (0)3-2540444

Sweden

Mitutoyo Scandinavia AB

Slåntvägen 6, 194 27 Upplands Väsby, SWEDEN
TEL: 46 (0)8 594 109 50 FAX: 46 (0)8 590 924 10

Mitutoyo Scandinavia AB / M³ Solution Center Alingsås

Ängsvaktaregatan 3A, 441 38 Alingsås, SWEDEN
TEL: 46 (0)8 594 109 50 FAX:46 (0)322 63 31 62

Mitutoyo Scandinavia AB / M³ Solution Center Värnamo

Kalkstensvägen 7, 331 44 Värnamo, SWEDEN
TEL: 46 (0)8 594 109 50 FAX: 46 (0)370 463 34

Switzerland

Mitutoyo (Schweiz) AG

Steinackerstrasse 35, 8902 Urdorf, SWITZERLAND
TEL: 41 (0)447361150

Mitutoyo (Suisse) SA

Rue Galilée 4, 1400 Yverdon-les Bains,
SWITZERLAND
TEL: 41 (0)244259422 FAX: 41 (0)447361151

Poland

Mitutoyo Polska Sp.z o.o.

Ul.Graniczna 8A, 54-610 Wrocław, POLAND
TEL: 48 (0)71354 83 50 FAX: 48 (0)71354 83 55

Czech Republic

Mitutoyo Česko s.r.o.

Dubská 1626, 415 01 Teplice, CZECH REPUBLIC
TEL: 420 417-514-011 Email: info@mitutoyo.cz

Mitutoyo Česko s.r.o. M³ Solution Center Ivančice

Ke Karlovu 62/10, 664 91 Ivančice, CZECH REPUBLIC
TEL: 420 417-514-011 Email: info@mitutoyo.cz

Mitutoyo Česko s.r.o. M³ Solution Center Ostrava Mošnov

Mošnov 314, 742 51 Mošnov, CZECH REPUBLIC
TEL: 420 417-514-050 Email: info@mitutoyo.cz

Mitutoyo Česko s.r.o. Slovakia Branch

Hviezdoslavova 124, 017 01 Povážská Bystrica,
SLOVAKIA
TEL: 421 948-595-590 Email: info@mitutoyo.sk

Hungary

Mitutoyo Hungária Kft.

Galamb József utca 9, 2000 Szentendre,
HUNGARY
TEL: 36 (30) 6410210

Romania

Mitutoyo Romania SRL

1A Drumul Garii Odai Street, showroom, Ground Floor, 075100 OTOPENI-ILFOV, ROMANIA
TEL: 40 (0)311012088 FAX: +40 (0)311012089

Showroom in Brasov

Strada Ionescu Crum Nr.1, Brasov Business Park
Tumul 1, Mezanin, 500446 Brasov-Judetul Brasov, ROMANIA
TEL/FAX: 40 (0)371020017

Russian Federation

Mitutoyo RUS LLC

Sharikopodshipnikovskaya St., 13, bld.5,
Moscow, 115088, RUSSIAN FEDERATION
TEL: 7 495 545 43 90

Finland

Mitutoyo Scandinavia AB Finnish Branch

Viherkiiittäjä 2A, 33960, Pirkkala, FINLAND
TEL: 358 (0)40 355 8498

Austria

Mitutoyo Austria GmbH

Salzburger Straße 260 / 3 A-4600 Wels, AUSTRIA
TEL: 43 (0)7242 219 998

Mitutoyo Austria GmbH Goetzis Regional showroom

Lastenstrasse 48a, 6840 Götzis, AUSTRIA

Singapore

Mitutoyo Asia Pacific Pte. Ltd.

Head office / M³ Solution Center

24 Kallang Avenue, Mitutoyo Building,
SINGAPORE 339415
TEL:(65)62942211 FAX:(65)62996666

Malaysia

Mitutoyo (Malaysia) Sdn. Bhd.

Kuala Lumpur Head Office / M³ Solution Center

Mah Sing Integrated Industrial Park, 4, Jalan Utari
U5/14, Section U5, 40150 Shah Alam, Selangor,
MALAYSIA
TEL:(60)3-78459318 FAX:(60)3-78459346

Penang Branch office / M³ Solution Center

30, Persiaran Mahsuri 1/2, Sunway Tunas,
11900 Bayan Lepas, Penang, MALAYSIA
TEL:(60)4-6411998 FAX:(60)4-6412998

Johor Branch office / M³ Solution Center

70 (Ground Floor), Jalan Molek 1/28, Taman
Molek, 81100 Johor Bahru, Johor, MALAYSIA
TEL:(60)7-3521626 FAX:(60)7-3521628

Thailand

Mitutoyo (Thailand) Co., Ltd.

Bangkok Head Office / M³ Solution Center

76/3-5, Chaengwattana Road, Kwaeng Anusaowaree,
Khet Bangkaen, Bangkok 10220, THAILAND
TEL:(66)2080 3500 FAX:(66)2521 6136

Chonburi Branch / M³ Solution Center

7/1, Moo 3, Tambon Bowin, Amphur Sriracha,
Chonburi 20230, THAILAND
TEL:(66)2080 3563 FAX:(66)3834 5788

ACC Branch / M³ Solution Center

122/8, 122/9, Moo 6, Tambon Donhuaroh,
Amphur Muangchonburi, Chonburi 20000,
THAILAND
TEL:(66)2080 3565

Indonesia

PT. Mitutoyo Indonesia

Head Office / M³ Solution Center

Jalan Sriwijaya No.26 Desa cibutu Kec. Cikarang
Selatan Kab. Bekasi 17530, INDONESIA
TEL: (62)21-2962 8600
FAX: (62)21-2962 8604

Vietnam

Mitutoyo Vietnam Co., Ltd

Hanoi Head Office / M³ Solution Center

1st & 2nd floor, MHDl Building, No. 60 Hoang Quoc
Viet Road, Nghia Do Ward, Cau Giay District, Hanoi,
VIETNAM
TEL:(84)24-3768-8963 FAX:(84)24-3768-8960

Ho Chi Minh City Branch Office / M³ Solution Center

Unit No. B-00.07, Ground Floor, C1 Building,
No. 6, Street D9, An Loi Dong Ward, Thu Duc
City, Ho Chi Minh City, VIETNAM
TEL:(84)28-3840-3489 FAX:(84)28-3840-3498

Hai Phong City Branch Office

Room 511, 5th Floor, Thanh Dat 3 Building, No.
4 Le Thanh Tong Street, May To Ward, Ngo
Quyen District, Hai Phong City, VIETNAM
TEL:(84)22-5398-9909

Philippines

Mitutoyo Philippines, Inc.

Head Office / M³ Solution Center

Unit 1B & 2B LTI, Administration Building 1, Annex
1, North Main Avenue, Laguna Technopark, Binan
Laguna 4024, PHILIPPINES
TEL/FAX:(63) 49 544 0272

India

Mitutoyo South Asia Pvt. Ltd. Head Office

C-122, Okhla Industrial Area, Phase-I, New
Delhi-110 020, INDIA
TEL: (91) 11-40578485/86

MSA Technical Center

Plot no. 65, Ground Floor, Udyog Vihar, Phase-4
Gurgaon, Haryana - 122016, INDIA
TEL : (91) 124-2340286/287

Mumbai Region Head office

303, Sentinel Hiranandani Business Park
Powai, Mumbai-400 076, INDIA
TEL: (91) 22-25700684/685/837/839

Pune Office / M³ Solution Center

G4/G5, Pride Kumar Senate, Off. Senapati
Bapat Road, Pune-411 016, INDIA
TEL:(91) 20-25660043/44/45

Ahmedabad Office / M³ Solution Center

A-104 & A-105, First Floor, Solitaire Corporate
Park, Near Divya Bhaskar Press, S.G. Road,
Ahmedabad - 380 015, INDIA
TEL: (91) 079 - 29704902/903

Bengaluru Region Head office / M³ Solution Center

116/117-2, Ground Floor, Sy. No. 93 & 94, 3rd
Phase, Peenya Industrial Area, Bengaluru-560
058, INDIA
TEL: (91) 80-25630946/47/48/49

Coimbatore Office

Regus, Srivari Srimath, 3rd Floor, Door No:1045,
Avinashi Road, Coimbatore - 641 018,INDIA
TEL: (91) 9345005663

Chennai Office / M³ Solution Center

No. 624, Anna Salai Teynampet, Chennai-600 018,
INDIA
TEL: (91) 44-24328823/24/25

Kolkata Office

Unit No. 1208,Om Tower, 32,J.L..Nehru Road,
Kolkata-700 071, INDIA
TEL: (91) 33-22267088/40060635/22266817

Taiwan

Mitutoyo Taiwan Co., Ltd. / M³ Solution Center Taipei

4F., No.71, Zhouzi St., Neihu Dist.,Taipei City
114, TAIWAN
TEL:886(2)5573-5900 FAX:886(2)8752-3267

Taichung Branch / M³ Solution Center Taichung

1F., No. 299, Gaotie 1st Rd., Wuri Dist.,
Taichung City 414, TAIWAN
TEL:886(4)2338-6822 FAX:886(4)2338-6722

Kaohsiung Branch / M³ Solution Center Kaohsiung

1F., No.31-1, Haibian Rd., Lingya Dist.,
Kaohsiung City 802, TAIWAN
TEL:886(7)334-6168 FAX:886(7)334-6160

South Korea

Mitutoyo Korea Corporation

Head Office / M³ Solution Center

(Sanbon-Dong, Geumjeong High View Build.),
6F, 153-8, Ls-Ro, Gunpo-Si, Gyeonggi-Do,
15808 KOREA
TEL:82(31)361-4200 FAX:82(31)361-4201

Busan Office / M³ Solution Center

(3150-3, Daejeo 2-dong) 8,Yutongdanji 1-ro
49beon-gil, Gangseo-gu, Busan, 46721 KOREA
TEL:82(51)324-0103 FAX:82(51)324-0104

Daegu Office / M³ Solution Center

(Galsan-dong, Daegu Business Center), 301-
Ho, 217, Seongseongondan-ro, Dalseo-gu,
Daegu 42704 KOREA
TEL:82(53)593-5602 FAX:82(53)593-5603

China

Mitutoyo Measuring Instruments (Shanghai) Co., Ltd.

8th Floor, Tower 1 Lujiazui Jinkong Square
No.1788/1800 Century Ave., Pudong New
District, Shanghai 200122, CHINA
TEL:86(21)5836-0718 FAX:86(21)5836-0717

Suzhou Office / M³ Solution Center (Suzhou)

No. 46 Baiyu Road, Suzhou 215021, CHINA
TEL:86(512)6522-1790 FAX:86(512)6251-3420

Wuhan Office / M³ Solution Corner

Room 1701, Wuhan Wanda Center, No. 96,
Linjiang Road, Wuchang District, Wuhan
Hubei 430060, CHINA
TEL:86(27)8544-8631 FAX:86(27)8544-6227

Chengdu Office

1-701, New Angle Plaza, 668# Jindong Road,
Jinjiang District, Chengdu, Sichuan 610066, CHINA
TEL:86(28)8671-8936 FAX:86(28)8671-9086

Hangzhou Office

Room 804, Eastern International Business
Center Building 1, No.600 Jinsha Road of
Hangzhou Economic and Technological
Development Zone, 310018, CHINA
TEL: 86(571)8288-0319 FAX: 86(571)8288-0320

**Tianjin Office / M³ Solution Center China
(Tianjin)**

Room D 12/F, TEDA Building, No.256 Jie-fang
Nan Road Hexi District, Tianjin 300042, CHINA
TEL:86(22)5888-1700 FAX:86(22)5888-1701

Changchun Office

Room 815, 8F, Building A1, Upper East
International No.3000 Dongsheng Street,
Erdao District, Changchun, Jilin, 130031, CHINA
TEL:86(431)8192-6998 FAX:86(431)8192-6998

Chongqing Office

Room 1312, Building 3, Zhongyu Plaza, No.86,
Hongjin Avenue, Longxi Street, Yubei District,
Chongqing, 400000, CHINA
TEL:86(23)6595-9950 FAX:86(23)6595-9950

Qingdao Office

Room 638, 6F, No.192 Zhengyang Road,
Chengyang District, Qingdao, Shandong, 266109,
CHINA
TEL:86(532)8096-1936 FAX:86(532)8096-1937

Xi'an Office

Room 805, Xi'an International Trade Center, No.
196 Xiaozhai East Road, Xi'an, 710061, CHINA
TEL:86(29)8538-1380 FAX:86(29)8538-1381

**Dalian Office / M³ Solution Center China
(Dalian)**

Room A-106 Shuijing SOHO, No.16 Harbin
Road, Economic Development Zone, Dalian, 116600
CHINA
TEL:86(411)8718 1212 FAX:86(411)8754-7587

Zhengzhou Office

Room1801, 18/F, Unit1, Building No.23, Shangwu
Inner Ring Road, Zhengdong New District, Zhengzhou
City, Henan 450018, CHINA
TEL:86(371)6097-6436 FAX:86(371)6097-6981

**Dongguan Office / M³ Solution Center
China (Dongguan)**

Room 801, No 65, Chang'an Section
Guanchang Road, Chang'an Town, Dongguan

City, Guangdong 523841, CHINA
TEL:86(769)8541 7715 FAX:86(769)-8541 7745

Fuzhou Office

Unit 03, 7th floor of East Tower, Sansheng
International Center, No.118 Wusi Road, Gulou
District, Fuzhou City, Fujian 350001, CHINA
TEL: 86 (591) 8761 8095
FAX: 86 (591) 8761 8096

Changsha Office

Room 2207, Building 1, Shiner International Plaza,
No. 88, Kaiyuan Middle Road, Changsha City, Hunan
410100, CHINA
TEL: 86 (731) 8401 9276
FAX: 86 (731) 8401 9376

Changzhou Office

Room 1502, Joint Financial Tower, No.255, Tongjiang
North Road, Tianning District, Changzhou City,
Jiangsu 2130002, CHINA
TEL:86(519)8815 8319 FAX:86(519)8815 8319

Wenzhou Office

Room 512, Building 4, Xinjingdujiayuan, Sanyang
Street, Ouhai District, Wenzhou City, Zhejiang
325014, CHINA

Shunde Office

Room 1603, Building 26, Vanke Golden Riverside
Plaza Phase II, No.13 Mid DeSheng Road, Shunde
District, Foshan City, Guangdong 528300, CHINA
TEL/FAX: 86(757)2228 8621

Mitutoyo Measuring Instruments (Suzhou) Co., Ltd.

No. 46 Baiyu Road, Suzhou 215021, CHINA
TEL:86(512)6252-2660 FAX:86(512)6252-2580

U.S.A.**Mitutoyo America Corporation**

965 Corporate Blvd., Aurora, IL 60502, U.S.A.
TEL:1-(630)820-9666
Toll Free No. 1-888-648-8869
FAX:1-(630)978-3501

**Headquarters (Aurora) / M³ Solution
Center**

965 Corporate Blvd., Aurora, IL 60502, U.S.A.

**Seattle (Renton) Office / M³ Solution
Center**

1000 SW 34th St. Suite G, Renton,
WA 98057 U.S.A.
TEL:1-(888)-648-8869

Houston Office / M³ Solution Center

4560 Kendrick Plaza Drive Suite 120 Houston, TX
77032, U.S.A.

TEL:1-(888)-648-8869 FAX:1-(281)227-0937

Cincinnati (Mason) Office / M³ Solution Center

6220 Hi-Tek Ct., Mason, OH 45040, U.S.A.

TEL:1-(888)-648-8869 FAX:1-(513)754-0718

Detroit (Novi) Office / M³ Solution Center

46850 Magellan Drive, Suite 100, Novi, MI 48377, U.S.A.

TEL:1-(888)-648-8869 FAX: 1-(248)-926-0928

Los Angeles (City of Industry) Office / M³ Solution Center

16925 E. Gale Ave., City of Industry,
CA 91745, U.S.A.

TEL:1-(888)-648-8869 FAX:1-(626)369-3352

Charlotte (Huntersville) Office / M³ Solution Center

11515 Vanstory Dr., Suite 140, Huntersville, NC
28078, U.S.A.

TEL:1-(888)-648-8869 FAX:1-(704)875-9273

Boston (Marlborough) Office / M³ Solution Center

753 Forest Street, Suite 110, Marlborough,
MA 01752, U.S.A.

TEL:1-(888)648-8869 FAX:1-(508)485-0782

Mitutoyo America Corporation Calibration Lab

965 Corporate Blvd., Aurora, IL 60502, U.S.A.

TEL:1-(888)-648-8869 FAX:1-(630)978-6477

Mitutoyo America Corporation CT-Lab Chicago

965 Corporate Blvd., Aurora, IL 60502, U.S.A.

TEL: 1-(888)-648-8869 FAX: 1-(630)-820-3418

Mitutoyo Research & Development America, Inc.

11533 NE 118th St., Kirkland,
WA 98034-7111, U.S.A.

TEL: 1-(425)821-3906 FAX: 1-(425)821-3228

Mitutoyo Research & Development America, Inc. - California Office

16925 Gale Ave. City of Industry,
CA 91745-1806 U.S.A.

TEL: 1-(425)821-3906 FAX: 1-(425)821-3228

Canada**Mitutoyo Canada Inc.**

2121 Meadowvale Blvd., Mississauga, Ont.
L5N 5N1., CANADA

TEL:1-(905)821-1261 FAX:1-(905)821-4968

Montreal Office

7075 Place Robert-Joncas Suite 129,
Montreal, Quebec H4M 2Z2, CANADA

TEL:1-(514)337-5994 FAX:1-(514)337-4498

Brazil**Mitutoyo Sul Americana Ltda.****Head office / M³ Solution Center**

Rodovia Índio Tibiriçá 1555, CEP 08655-000 -
Vila Sol Nascente - Suzano - SP - BRASIL

TEL: 55 (11) 5643-0004/0041

Filial Campinas / M³ Solution Center

Avenida Francisco Alfredo Junior, nº 307, Sala
01 e 02, Bairro Swiss Park – Campinas – São
Paulo – BRASIL CEP 13049255

TEL: 55 (19) 3397-3412

Filial Curitiba / M³ Solution Center

Rua Sergipe, nº 101, Sala A, Bairro Boneca
do Iguaçu, São José dos Pinhais – Paraná –
BRASIL CEP 83040120

TEL: 55 (41) 3534-1728

Argentina**Mitutoyo Sul Americana Ltda.****Argentina Branch / M³ Solution Center**

Av. B. Mitre 891/899 – C.P. (B1603CQI)
Vicente López –Pcia. Buenos Aires –
ARGENTINA

TEL:54 (11) 4730-1433 FAX:54 (11) 4730-1411

Sucursal Cordoba / M³ Solution Center

Av. Ricchieri 2872 L.4 – Bº Jardim – CP
X5014OPJ Cordoba, ARGENTINA

TEL:54 (351) 464-4125

Mexico**Mitutoyo Mexicana, S.A. de C.V.**

Industria Eléctrica No.15, Parque Industrial,
Naucaipan de Juárez, Estado de México
C.P.53370, MÉXICO

TEL: 52 (01-55) 5312-5612

FAX: 52 (01-55) 5312-3380

Monterrey Office / M³ Solution Center

Blv. Interamericana No. 103, Parque Industrial
FINSA, C.P. 66636 Apodaca, N.L., MÉXICO
TEL: 52(01-81) 8398-8227/8228/8242/8244
FAX: 52(01-81) 8398-8226

Tijuana Office / M³ Solution Center

Calle José María Velazco 10501-C, Col. Cd.
Industrial Nueva Tijuana, C.P. 22500 Tijuana, B.C.,
MÉXICO
TEL: 52 (01-664) 647-5024

Querétaro Office / M³ Solution Center

Av. Cerro Blanco No.500-1, Colonia Centro Sur,
Querétaro, Querétaro, C.P. 76090,
MÉXICO
TEL: 52 (01-442) 340-8018, 340-8019 and 340-
8020
FAX: 52 (01-442) 340-8017

**Mitutoyo Mexicana, S.A. de C.V. Querétaro
Calibration Laboratory**

Av. Cerro Blanco 500 30 Centro Sur,
Querétaro, Querétaro, C.P. 76090, MÉXICO
TEL: 52 (01-442) 340-8018, 340-8019 and 340-8020
FAX: 52 (01-442) 340-8017

**Aguascalientes Office / M³ Solution
Center**

Av. Aguascalientes No. 622, Local 15 Centro
Comercial El Cilindro Fracc. Pulgas Pandas
Norte, C.P. 20138, Aguascalientes, Ags. MÉXICO
TEL: 52 (01-449) 174-4140 and 174-4143

Irapuato Office / M³ Solution Center

Boulevard a Villas de Irapuato No. 1460 L.1 Col. Ejido
Irapuato C.P. 36643
Irapuato, Gto., MÉXICO
TEL: 52 (01-462) 144-1200 and 144-1400

Revision History

Date of publication	No. of revisions	Revision details
October 1, 2018	Third edition	Publication of fully revised edition
January 1, 2023	Fourth edition	Changes due to Brexit

Mitutoyo Corporation

20-1, Sakado 1-Chome, Takatsu-ku, Kawasaki-shi, Kanagawa 213-8533, Japan
Tel: +81 (0)44 813-8230 Fax: +81 (0)44 813-8231
Home page: <https://www.mitutoyo.co.jp/global.html>

For the EU Directive, Authorized representative and importer in the EU:
Mitutoyo Europe GmbH
Borsigstrasse 8-10, 41469 Neuss, Germany

For the UK Regulation, Authorized representative and importer in the UK:
Mitutoyo (UK) Ltd.
Joule Road, West Point Business Park, Andover, Hampshire SP10 3UX,
UNITED KINGDOM

Printed in Japan

No. 99MAK004B