

Keysight Series 654xA, 655xA, 664xA, 665xA GPIB DC Power Supplies

Service Manual

NOTICE: This document contains references to Agilent Technologies. Agilent's former Test and Measurement business has become Keysight Technologies. For more information, go to www.keysight.com.



CERTIFICATION

Keysight Technologies certifies that this product met its published specifications at time of shipment from the factory. Keysight Technologies further certifies that its calibration measurements are traceable to the United States National Bureau of Standards, to the extent allowed by the Bureau's calibration facility, and to the calibration facilities of other International Standards Organization members.

WARRANTY

This Keysight Technologies hardware product is warranted against defects in material and workmanship for a period of three years from date of delivery. Keysight Technologies software and firmware products, which are designated by Keysight Technologies for use with a hardware product and when properly installed on that hardware product, are warranted not to fail to execute their programming instructions due to defects in material and workmanship for a period of 90 days from date of delivery. During the warranty period Keysight Technologies will, at its option, either repair or replace products which prove to be defective. Keysight Technologies does not warrant that the operation of the software, firmware, or hardware shall be uninterrupted or error free.

For warranty service, with the exception of warranty options, this product must be returned to a service facility designated by Keysight Technologies. Customer shall prepay shipping charges by (and shall pay all duty and taxes) for products returned to Keysight Technologies for warranty service. Except for products returned to Customer from another country, Keysight Technologies shall pay for return of products to Customer.

Warranty services outside the country of initial purchase are included in Keysight Technologies product price, only if Customer pays Keysight Technologies international prices (defined as destination local currency price, or U.S. or Geneva Export price).

If Keysight Technologies is unable, within a reasonable time to repair or replace any product to condition as warranted, the Customer shall be entitled to a refund of the purchase price upon return of the product to Keysight Technologies.

LIMITATION OF WARRANTY

The foregoing warranty shall not apply to defects resulting from improper or inadequate maintenance by the Customer, Customer-supplied software or interfacing, unauthorized modification or misuse, operation outside of the environmental specifications for the product, or improper site preparation and maintenance. **NO OTHER WARRANTY IS EXPRESSED OR IMPLIED. KEYSIGHT TECHNOLOGIES SPECIFICALLY DISCLAIMS THE IMPLIED WARRANTIES OF MERCHANTABILITY AND FITNESS FOR A PARTICULAR PURPOSE.**

EXCLUSIVE REMEDIES

THE REMEDIES PROVIDED HEREIN ARE THE CUSTOMER'S SOLE AND EXCLUSIVE REMEDIES. KEYSIGHT SHALL NOT BE LIABLE FOR ANY DIRECT, INDIRECT, SPECIAL, INCIDENTAL, OR CONSEQUENTIAL DAMAGES, WHETHER BASED ON CONTRACT, TORT, OR ANY OTHER LEGAL THEORY.

ASSISTANCE

The above statements apply only to the standard product warranty. Warranty options, extended support contracts, product maintenance agreements and customer assistance agreements are also available. Contact your nearest Keysight Technologies Sales and Service office for further information on Keysight Technologies' full line of Support Programs.

SAFETY CONSIDERATIONS

GENERAL. This is a Safety Class 1 instrument (provided with terminal for connection to protective earth ground).

OPERATION. BEFORE APPLYING POWER verify that the product is set to match the available line voltage, the correct line fuse is installed, and all safety precautions (see following warnings) are taken. In addition, note the instrument's external markings described under "Safety Symbols".

WARNING.

- Servicing instructions are for use by service-trained personnel. To avoid dangerous electrical shock, do not perform any servicing unless you are qualified to do so.
- BEFORE SWITCHING ON THE INSTRUMENT, the protective earth terminal of the instrument must be connected to the protective conductor of the (mains) power cord. The mains plug shall be inserted only in an outlet socket that is provided with a protective earth contact. This protective action must not be negated by the use of an extension cord (power cable) that is without a protective conductor (grounding). Grounding one conductor of a two-conductor outlet is not sufficient protection.
- If this instrument is to be energized via an auto-transformer (for voltage change), make sure the common terminal is connected to the earth terminal of the power source.
- Any interruption of the protective (grounding) conductor (inside or outside the instrument), or disconnecting of the protective earth terminal will cause a potential shock hazard that could result in personal injury.
- Whenever it is likely that the protective earth connection has been impaired, this instrument must be made inoperative and be secured against any unintended operation.
- Only fuses with the required rated current, voltage, and specified type (normal blow, time delay, etc.) should be used. Do not use repaired fuses or short-circuited fuseholders. To do so could cause a shock or fire hazard.
- Do not operate this instrument in the presence of flammable gases or fumes.
- Do not install substitute parts or perform any unauthorized modification to this instrument.
- Some procedures described in this manual are performed with power supplied to the instrument while its protective covers are removed. If contacted, the energy available at many points may result in personal injury.
- Any adjustment, maintenance, and repair of this instrument while it is opened and under voltage should be avoided as much as possible. When this is unavoidable, such adjustment, maintenance, and repair should be carried out only by a skilled person who is aware of the hazard involved.
- Capacitors inside this instrument may hold a hazardous electrical charge even if the instrument has been disconnected from its power source.

SAFETY SYMBOLS.



Instruction manual symbol. The instrument will be marked with this symbol when it is necessary for you to refer to the instruction manual in order to protect against damage to the instrument.



This sign indicates hazardous voltages.

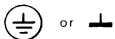



















This sign indicates an earth terminal (sometimes used in the manual to indicate circuit common connected to a ground chassis).

WARNING

The WARNING sign denotes a hazard. It calls attention to a procedure, practice, or the like, which, if not correctly performed or adhered to, could result in personal injury. Do not proceed beyond a WARNING sign until the indicated conditions are fully understood and met.

CAUTION

The CAUTION sign denotes a hazard. It calls attention to an operating procedure, or the like, which, if not correctly performed or adhered to, could result in damage to or destruction of part or all of the product. Do not proceed beyond a CAUTION sign until the indicated conditions are fully understood and met.

Safety Symbol Definitions			
Symbol	Description	Symbol	Description
	Direct current		Terminal for Line conductor on permanently installed equipment
	Alternating current		Caution, risk of electric shock
	Both direct and alternating current		Caution, hot surface
	Three-phase alternating current		Caution (refer to accompanying documents)
	Earth (ground) terminal		In position of a bi-stable push control
	Protective earth (ground) terminal (Intended for connection to external protective conductor.)		Out position of a bi-stable push control
	Frame or chassis terminal		On (supply)
	Terminal for Neutral conductor on permanently installed equipment		Off (supply)
	Terminal is at earth potential (Used for measurement and control circuits designed to be operated with one terminal at earth potential.)		Standby (supply) Units with this symbol are not completely disconnected from ac mains when this switch is off. To completely disconnect the unit from ac mains, either disconnect the power cord or have a qualified electrician install an external switch.

Notice

The information contained in this document is subject to change without notice. Keysight Technologies makes no warranty of any kind with regard to this material, including but not limited to, the implied warranties of merchantability, and fitness for a particular purpose.

Keysight Technologies shall not be liable for errors contained herein or for incidental or consequential damages in connection with the furnishing, performance or use of this material.

This document contains proprietary information which is protected by copyright. All rights are reserved. No part of this document may be photocopied, reproduced, or translated into another language without the prior written consent of Keysight Technologies.

© Copyright 1993, 2000, 2014 Keysight Technologies

Printing History

The edition and current revision of this manual are indicated below. Reprints of this manual containing minor corrections and updates may have the same printing date. Revised editions are identified by a new printing date. A revised edition incorporates all new or corrected material since the previous printing date.

Edition 1July, 1993

Edition 2 September, 2000

Edition 3 December, 2014

Table of Contents

Introduction	7
Scope	7
Conventions Used In Text.....	7
Manual Revisions.....	8
Safety Considerations	8
Firmware Revisions	8
Electrostatic Discharge	8
Verification.....	9
Introduction.....	9
Test Equipment Required.....	9
Measurement Techniques.....	11
Setup for Most Tests	11
Electronic Load.....	11
Current-Monitoring Resistor	11
Operation Verification Tests.....	11
Performance Tests.....	11
Programming.....	13
Constant Voltage (CV) Tests	13
CV Setup.....	13
Voltage Programming and Readback Accuracy.....	13
CV Load Effect	14
CV Source Effect	14
CV Noise (PARD).....	14
Transient Recovery Time	15
Constant Current (CC) Tests	15
CC Setup	15
Current Programming and Readback Accuracy	15
Current Sink (CC-) Operation.....	16
CC Load and Line Regulation.....	16
CC Load Effect	16
CC Source Effect.....	17
CC Noise (PARD).....	17
Troubleshooting.....	31
Introduction.....	31
Test Equipment Required.....	31
Overall Troubleshooting	34
Power-On Self-Test.....	34
Signature Analysis	35
Firmware Revisions (for Models 664xA & 665xA).....	41
Test Headers	41
Troubleshooting Procedures	49
Flow Charts.....	49
Bias and Reference Supplies.....	49
CV/CC Status Annunciators Troubleshooting.....	49
Post Repair Calibration.....	49
Inhibit Calibration Jumper	49
Calibration Password	50
EEPROM Initialization.....	66
Transferring Calibration Constants Into Factory Preset Locations	66

Disassembly Procedures	72
List of Required Tools	74
Top Cover, Removal & Replacement	74
A2 GPIB Board, Removal & Replacement (for 664xA & 665xA Models Only)	74
A2 Isolator Board, Removal & Replacement (for 654xA & 655xA Only)	75
Front Panel Assembly, Removal and Replacement	75
S1 Line Switch, Removal and Replacement	76
A3 Front Panel Board, Removal and Replacement	76
A1 Main Board	77
A4 Heatsink Assembly (500 Watt Models 6x5xA Only)	77
A4A1 or A4A3 Left Tunnel Board, Removal and Replacement	78
A4A2 or A4A4 Right Tunnel Board	78
B1 Fan, Removal and Replacement	78
T1 Power Transformer, Removal and Replacement	78
Principles of Operation	81
Introduction	81
I/O INTERFACE SIGNALS	81
Overall Block Diagram (Figure 4-2)	83
Detailed Block Diagram Discussion	83
Secondary Interface Circuits (Figure 4-3)	83
Output Power and Control Circuits (Figure 4-4)	86
Output Power	86
Control Circuits	86
A3 Front Panel Board Circuits (Figure 4-5)	89
A2 GPIB Board Circuits For Keysight Models 664xA and 665xA Only	90
Isolator Board Circuits for Keysight Models 654xA and 665xA Only (Figure 4-7)	91
Replaceable Parts	95
Introduction	95
Chapter Organization	95
Model Applicability	95
How To Order Parts	95
Diagrams	137
Introduction	137
Interconnections	137
AC Input and Transformer Connections	137
Circuit Board Schematics	137
Component Location Diagrams	137
Test Points	139
Manual Backdating Changes	169
Index	173

Introduction

Scope

This manual contains information for troubleshooting and repairing four generic models of Keysight power supplies. The different power supply models described in this manual are listed in Table 1-1.

Note The information provided in this manual applies to all Keysight models listed in Table 1-1. Where differences exist among any of the models, these differences are explained in text.

For installation, operation, programming, and calibration procedures, refer to the appropriate Operating Manual as listed in Chapter 2, Table 2-1. For information in determining the performance level of the power supply, either before or after repair, refer to Chapter 2, Verification. The functional circuit operation of the various Keysight models is described in Chapter 4. Replaceable parts lists and circuit diagrams are included in Chapters 5 and 6, respectively.

Table 1-1. Keysight Power Supplies Described In This Manual

Keysight Models	200 Watt Models	500 Watt Models
GPIB	Keysight 6641A-6645A	Keysight 6651A-6655A
Analog Programmable	Keysight 6541A-6545A	Keysight 6551A-6555A

Conventions Used In Text

1. Power supply models can be divided into 200 watt and 500 watt models. A "4" in the third position of the model number indicates a 200 watt supply, while the digit "5" in the third position indicates a 500 watt unit.
2. In addition, power supplies can be divided according to GPIB supplies or Analog Programmable supplies. All GPIB models have a "6" in the second position of the model number, while Analog Programmable supplies have a "5" in the second position of the model number. The GPIB models include a GPIB board which permits communications between the supply and an external computer over the GPIB bus. Analog Programmable supplies use an Isolator Board instead of the GPIB board, and do not have the ability to communicate with an external computer.
3. When referring in text to either the 200 watt or 500 watt GPIB power supply models, the convention "models 664xA or 665xA," respectively, is used. When referring to either the 200 watt or 500 watt non- GPIB (or Analog Programmable) models, the convention "models 654xA or 655xA," respectively, is used.
4. In this manual all complementary signal names in text are shown with an asterisk (*) after the signal name. Example; PCLR*. In some schematic diagrams you may see a bar above the signal name, which is identical to the signal name shown in text with an asterisk.

Manual Revisions

Keysight Technologies instruments are identified by a ten-character, serial number, such as, US36360101. This manual was written for power supplies with serial numbers equal to, or higher than, those shown on the title page.

If the serial number on the rear panel of your power supply is higher than the one on the title page, then the power supply was made after publication of this manual, and may have hardware and/or firmware differences not covered in this manual. If there are such differences, they are documented in one or more yellow “Manual Changes” sheets sent with the manual.

If the serial number of your power supply is below that listed on the title page, or if it uses an older serial number format such as 3023A-01456, then your power supply was made prior to those covered in this manual. If this is the case, refer to Appendix A for any backdating information that may apply.

Safety Considerations

This product is a Safety Class 1 instrument that has a protective earth terminal. Refer to the Safety Summary page at the beginning of this manual for general safety procedures and for the meaning of safety symbols appearing in the manual and on the power supply.

WARNING

Hazardous voltages exist within the power supply chassis, at the output terminals, and at the programming terminals.

Firmware Revisions

The supply's firmware resides in the front panel board's ROM chip (A3U4), and in the main board's microprocessor chip (AIU504). For models 664xA and 665xA, firmware also resides in the GPIB board ROM chip (A2U106).

For GPIB models 664xA and 665xA, you can use the “*IDN?” query, as described in Chapter 3, to get the firmware revision numbers of your power supply's firmware. For Keysight models 654xA and 655xA, the revision number can be read from the label affixed atop the IC chip.

Electrostatic Discharge

CAUTION

The power supply has components that can be damaged by ESD (electrostatic discharge). Failure to observe standard antistatic practices can result in serious degradation of performance, even if complete failure does not occur.

When working on the power supply, observe all standard antistatic work practices. This includes, but is not limited to:

- Working at a static-free station, such as, a table covered with static-dissipative laminate or with a Keysight 9300-0797 conductive table mat.
- Using a conductive wrist strap, such as, a Keysight 9300-0969 or a Keysight 9300-0970 wrist strap.
- Grounding all metal equipment at the station to a single, common ground.
- Connecting low-impedance test equipment to static-sensitive components only when those components have power applied to them.
- Removing power from the power supply before removing, or installing, printed circuit boards.

Verification

Introduction

This Chapter contains test procedures to verify that the Keysight Power Supply is operating normally. There are three types of tests as follows:

Test	Description
Built-In Self-Tests	These tests are run automatically when the power supply is turned on.
Operation Verification	These tests verify that the power supply is operating normally but the tests do not check all specified operating parameters.
Performance Tests	These tests check that the supply meets all of the operating specifications as listed in the Operating Manual.

Note The power supply must pass the built-in self-tests before the tests in this chapter can be performed. If the supply fails the self test, refer to the overall troubleshooting procedures in Chapter 3 of this manual.

If any failures are encountered, or if abnormal test results are observed, refer to the Troubleshooting Procedures in Chapter 3 of this manual. The troubleshooting procedures will determine if repair and/or calibration is required. Calibration procedures are given in Appendix A of the appropriate Operating Manual.

Table 2-1. Applicable Keysight Power Supply Operating Manuals

For Keysight Model	Operating Manual Part Number
GPIB Models 664xA & 665xA	5959-3350
Analog Programmable Models 654xA & 655xA	5959-3374

Test Equipment Required

Table 2-2 lists the equipment required to perform the verification tests. Measurement uncertainties in the Performance Test Record Tables (given later in this chapter) are calculated using the recommended test equipment in Table 2-2.

WARNING

SHOCK HAZARD. The test should only be performed by qualified personnel. During the performance of these tests, hazardous voltages may be present at the output of the supply.

Table 2-2. Test Equipment Required for Verification

Type	Required Characteristics	Recommended Model
Current Monitor Resistor	100 A (0.01 Ω) \pm 0.04% for Keysight 6541A, 6551A, 6552A, 6641A, 6651A, & 6652A models.	Guildline 9230/100
	15 A (0.1 Ω) \pm 0.04% for Keysight 6542A, 6543A, 6544A, 6545A, 6553A, 6554A, 6555A, 6642A, 6643A, 6644A, 6645A, 6653A, 6654A, 6655A models.	Guildline 9230/15
DC Power Supply	5 V @ 10 A	Keysight 66 Keysight 42A, 6653A
Digital Voltmeter	Resolution: 10 nV @ 1 V Readout: 8 1/2 digits Accuracy: 20 ppm	Keysight 3458A
Electronic Load	Voltage and current range must exceed range of supply under test. Power range: 250 W minimum	Keysight 6050A mainframe with Keysight 60504A (60 V) plug-in module or Keysight 60504A-J10 (120 V) plug-in module.
GPIB Controller¹	Full GPIB capabilities	HP Series 200/300
Load Resistor	0.1 Ω \pm 5%, 300 W for Keysight 6541A, 6641A, 6551A, 6651A, 6552A, 6652A models.	Ohmite C300KRIO
	1.0 Ω \pm 5%, 300 W for Keysight 6542A, 6543A, 6544A, 6545A, 6553A, 6554A, 6555A, 6642A, 6643A, 6644A, 6645A, 6653A, 6654A, 6655A models.	Ohmite C300KIRO
Oscilloscope	Sensitivity: 1 mV Bandwidth Limit: 20 MHz Probe: 1:1 with RF tip	Keysight 54111A
RMS Voltmeter	True RMS Bandwidth: 20 MHz Sensitivity: 100 μ V	Keysight 3400B
Variable-Voltage Transformer	Adjustable from -13% to +6% of input range. Power: 1 kVA minimum.	

¹ For 664xA and 665xA models only.

Measurement Techniques

Setup for Most Tests

Most tests are performed at the rear terminals of the supply as shown in Figure 2-1. Measure the DC voltage directly at the +S and -S terminals. Set the output for remote sensing and use adequate wire gauge for the load leads as described in Chapter 4 of the Operating Manual.

Note All tests are performed as follows: Set the SENSE switch at the back of the supply to the Remote position. Connect the remote sensing leads from +OUT to +S, and from -OUT to -S.

Electronic Load

Many of the test procedures require the use of a variable load capable of dissipating the required power. If a variable resistor is used, switches must be used to either; connect, disconnect, or short the load resistor. For most tests, an electronic load can be used. The electronic load is considerably easier to use than load resistors, but it may not be fast enough to test transient recovery time and may be too noisy for the noise (PARD) tests.

Fixed load resistors may be used in place of a variable load, with minor changes to the test procedures in this chapter. Also, if computer controlled test setups are used, the relatively slow (compared to computers and system voltmeters) settling times and slew rates of the power supply may have to be taken into account. "Wait" statements can be used in the test program if the test system is faster than the supply.

Current-Monitoring Resistor

To eliminate output-current measurement error caused by voltage drops in the leads and connections, connect the current monitoring resistor between the -OUT and the load as a four terminal device. Connect the current-monitoring leads inside the load-lead connections directly at the monitoring points on the resistor element.

Operation Verification Tests

To assure that the supply is operating properly, without testing all specified parameters, perform the following test procedures:

- a. Perform the turn-on and checkout procedures given in Chapter 3 of the Operating Manual.
- b. Perform the Voltage Programming and Readback Accuracy test, and the Current Programming and Readback Accuracy Performance test which are given in this chapter.

Performance Tests

Note A full Performance Test consists of those items listed as Specifications in Table 1-1 of the Operating Manual, that have a procedure in the Verification section of this chapter.

The following paragraphs provide test procedures for verifying the supply's compliance with the specifications listed in Table 1-1 of the Operating Manual. All of the performance test specifications are listed in the appropriate Performance Test Record Form for your specific model. You can record the actual measured values in the column provided in this form.

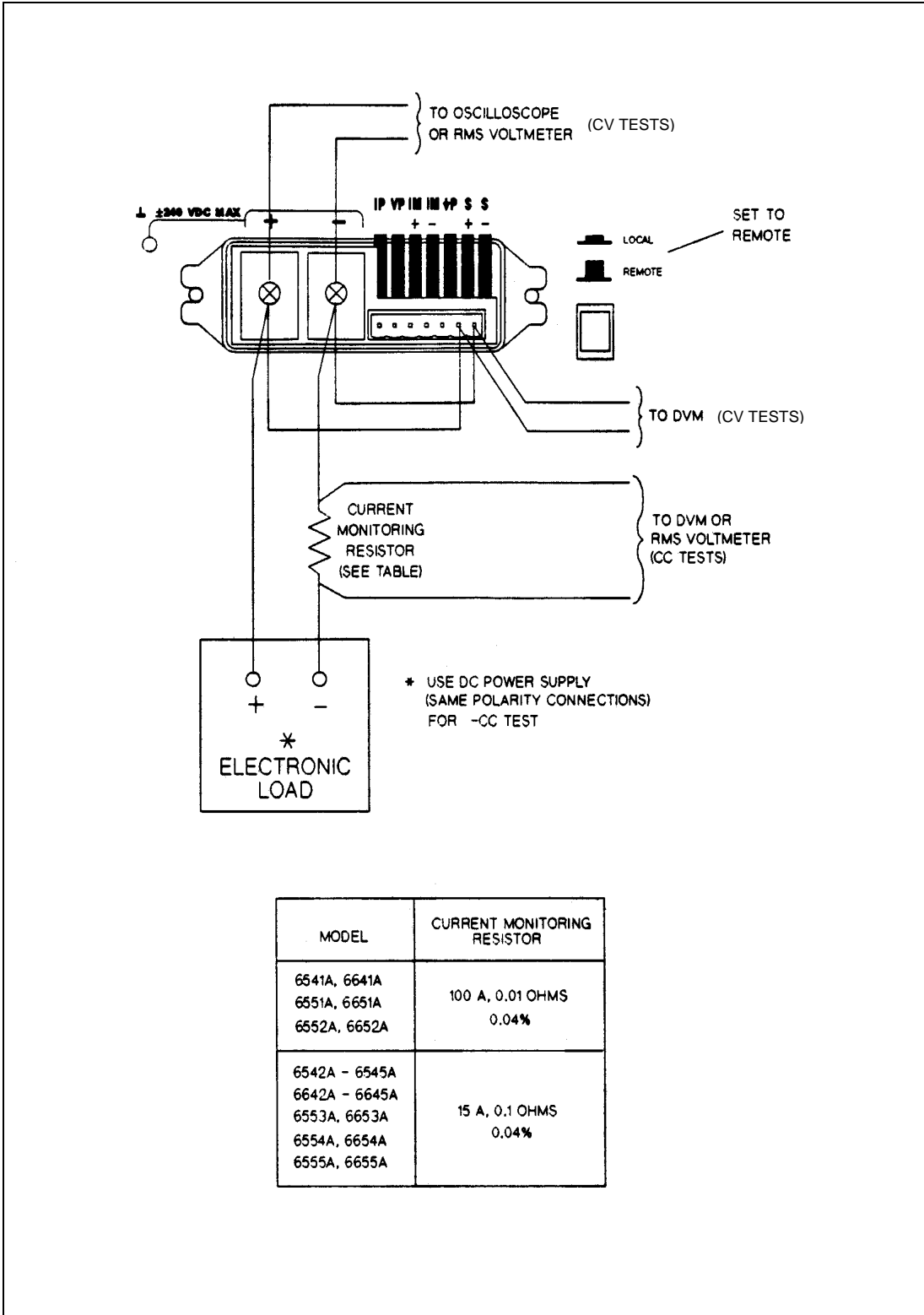

Figure 2-1. Basic Test Setup

Programming

You can program the supply from the front panel keyboard or from a GPIB controller (for models 664xA and 665xA) when performing the tests. The test procedures are written assuming that you know how to program the supply either; remotely from a GPIB controller (for 664xA and 665xA models), or locally using the control keys and indicators on the supply's front panel. For models 654xA and 655xA you must use the front panel. Complete instructions on remote and local programming are given in the Operating Manual.

Constant Voltage (CV) Tests

CV Setup

If more than one meter or if a meter and an oscilloscope are used, connect each to the terminals by a separate pair of leads to avoid mutual coupling effects. For constant voltage DC tests, connect only to +S and -S, since the unit regulates the output voltage that appears between +S and -S, and not between the (+) and (-) output terminals. Use coaxial cable or shielded two-wire cable to avoid noise pickup on the test leads.

Voltage Programming and Readback Accuracy

This test verifies that the voltage programming, GPIB readback (on 664xA and 665xA models), and front panel display functions are within specifications. Note that the values read back over the GPIB should be identical to those displayed on the front panel.

- Turn off the supply and connect a digital voltmeter between the +S and the -S terminals as shown in Figure 2-1.
- Turn on the supply and program the supply to zero volts and the maximum programmable current (see Table 2-3) with the load off.
- Record the output voltage readings on the digital voltmeter (DVM) and the front panel display. The readings should be within the limits specified in the performance test record form for the appropriate model under CV PROGRAMMING @ 0 VOLTS. Also, note that the CV annunciator is on. The output current reading should be approximately zero.
- Program the output voltage to full-scale (see Table 2-3).
- Record the output voltage readings on the DVM and the front panel display. The readings should be within the limits specified in the performance test record form for the appropriate model under CV PROGRAMMING @ FULL SCALE.

Table 2-3. Voltage and Current Values

Keysight Model	Full-Scale Voltage	Max. Prog. Voltage	Full-Scale Current	Max. Prog. Current	Max. Prog. Overvoltage
200 Watt Supplies					
6541A, 6641A	8 V	8.190 V	20 A	20.475 A	8.8 V
6542A, 6642A	20 V	20.475 V	10 A	10.237 A	22 V
6543A, 6643A	35 V	35.831 V	6 A	6.142 A	38.5 V
6544A, 6644A	60 V	61.425 V	3.5 A	3.583 A	66.0 V
6545A, 6645A	120 V	122.85 V	1.5 A	1.535 A	132 V
500 Watt Supplies					
6551A, 6651A	8 V	8.190 V	50 A	51.188 A	8.8 V
6552A, 6652A	20 V	20.475 V	25 A	25.594 A	22 V
6553A, 6653A	35 V	35.831 V	15 A	15.536 A	38.5 V
6554A, 6654A	60 V	61.425 V	9 A	9.214 A	66.0 V
6555A, 6655A	120 V	122.85 V	4 A	4.095 A	132 V

CV Load Effect

This test measures the change in output voltage resulting from a change in output current from full load to no load.

- a. Turn off the supply and connect the output as shown in Figure 2-1 with the DVM connected between the +S and -S terminals.
- b. Turn on the supply and program the current to the maximum programmable value and the voltage to the full-scale value (see Table 2-3).
- c. Adjust the load for the full-scale current (see Table 2-3) as indicated on the front panel display. The CV annunciator on the front panel must be on. If it is not, adjust the load so that the output current drops slightly.
- d. Record the output voltage reading on the DVM connected to +S and -S.
- e. Open the load and again record the DVM voltage reading.

The difference between the DVM readings in steps (d) and (e) is the load effect voltage, and should not exceed the value listed in the Performance Test Record Form for the appropriate model under CV LOAD EFFECT.

CV Source Effect

This test measures the change in output voltage that results from a change in AC line voltage from the minimum to maximum value within the line voltage specifications.

- a. Turn off the supply and connect the AC power line through a variable voltage transformer.
- b. Connect the output as shown in Figure 2-1 with the DVM connected between the +S and the -S terminals. Set the transformer to nominal line voltage.
- c. Turn on the supply and program the current to the maximum programmable value and the output voltage to the full-scale value (see Table 2-3).
- d. Adjust the load for the full-scale current value (see Table 2-3) as indicated on the front panel display. The CV annunciator on the front panel must be on. If it is not, adjust the load so that the output current drops slightly.
- e. Adjust the transformer to 13% below the nominal line voltage (e.g., 104.4 Vac for a 120 Vac nominal line voltage input).
- f. Record the output voltage reading on the DVM.
- g. Adjust the transformer to 6% above the nominal line voltage (e.g., 127.2 Vac for 120 Vac nominal line voltage input).
- h. Record the output voltage reading on the DVM.

The difference between the DVM reading in steps (f) and (h) is the source effect voltage and should not exceed the value listed in the Performance Test Record Form for the appropriate model under CV SOURCE EFFECT.

CV Noise (PARD)

Periodic and random deviations (PARD) in the output (ripple and noise) combine to produce a residual AC voltage superimposed on the DC output voltage. CV PARD is specified as the rms or peak-to-peak output voltage in a frequency range from 20 Hz to 20 MHz.

- a. Turn off the supply and connect the output as shown in Figure 2-1 to an oscilloscope (AC coupled) between the (+) and the (-) terminals. Set the oscilloscope's bandwidth limit to 20 MHz and use an RF tip on the oscilloscope probe.
- b. Turn on the supply and program the current to the maximum programmable value and the output voltage to the full-scale value (see Table 2-3).
- c. Adjust the load for the full-scale current value (see Table 2-3) as indicated on the front panel display.
- d. Note that the waveform on the oscilloscope should not exceed the peak-to-peak limits in the Performance Test Record Form for the appropriate model under CV NOISE (PARD).
- e. Disconnect the oscilloscope and connect an AC rms voltmeter in its place. The rms voltage reading should not exceed the RMS limits in the Performance Test Record Form for the appropriate model under CV NOISE (PARD).

Transient Recovery Time

This test measures the time for the output voltage to recover to within the specified value following a 50% change in the load current.

- Turn off the supply and connect the output as in Figure 2-1 with the oscilloscope across the +S and the -S terminals.
- Turn on the supply and program the output voltage to the full-scale value and the current to the maximum programmable value (see Table 2-3).
- Set the load to the Constant Current mode and program the load current to 1/2 the power supply full-scale rated current.
- Set the electronic load's transient generator frequency to 100 Hz and its duty cycle to 50%.
- Program the load's transient current level to the supply's full-scale current value and turn the transient on.
- Adjust the oscilloscope for a waveform similar to that in Figure 2-2.
- The output voltage should return to within 0.1% or 20 mV, whichever is greater, of the nominal value in less than 100 microseconds. Check both loading and unloading transients by triggering on the positive and negative slope.

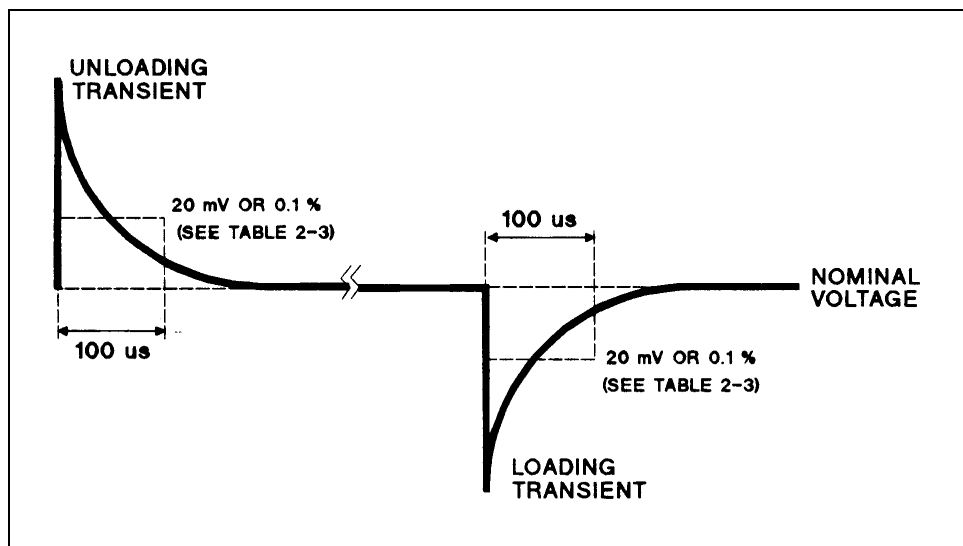

Figure 2-2. Transient Response Waveform

Constant Current (CC) Tests

CC Setup

Follow the general setup instructions in the Measurement Techniques paragraph and the specific instructions given in the following paragraphs.

Current Programming and Readback Accuracy

This test verifies that the current programming and readback are within specification. The accuracy of the current monitoring resistor must be 0.04% or better.

- Turn off the supply and connect the current monitoring resistor across the output and a DVM across the resistor. See Current Monitoring Resistor.
- Turn on the supply and program the output voltage to 5 V and the current to zero.
- Divide the voltage drop (DVM reading) across the current monitoring resistor by its resistance to convert to amps and record this value (I_{out}). Also, record the current reading on the front panel display. The readings should be within the limits specified in the Performance Test Record Form for the appropriate model under CC PROGRAMMING @ 0 AMPS.
- Program the output voltage to 5 V and the current to full-scale (see Table 2-3).

- e. Divide the voltage drop (DVM reading) across the current monitoring resistor by its resistance to convert to amps and record this value (Iout). Also, record the current reading that appears on the front panel display. The readings should be within the limits specified in the performance test record form for the appropriate model under CC PROGRAMMING @ FULL-SCALE.

Current Sink (CC-) Operation.

This test verifies current sink operation and readback.

- a. Turn off the supply and connect the output as shown in Figure 2-1, except connect a DC power supply in place of the electronic load as indicated.
- b. Set the external power supply to 5 V and its current limit to 20% of the full scale current value (see Table 2-3) of the supply under test. For example, if the full scale current value is 25 A, set the external supply's current limit to 5 A.
- c. Turn on the supply under test and program the output voltage to zero. The current on the UUT display should be approximately 20% of the full-scale current.
- d. Divide the voltage drop across the current monitoring resistor by its resistance to obtain the current sink value in amps and subtract this from the current reading on the display. The difference between the readings should be within the limits specified in the Performance Test Record Form for the appropriate model under, CURRENT SINK DISPLAY AND READBACK.

CC Load and Line Regulation

These tests (CC Load Effect and CC Source Effect given below) are tests of the DC regulation of the power supply's output current. To insure that the values read are not the instantaneous measurement of the AC peaks of the output current ripple, several DC measurements should be made and the average of these reading calculated. An example of how to do this is given below using a Keysight 3458A System Voltmeter programmed from the front panel. Set up the voltmeter and execute the "Average Reading" program as follows:

- a. Program 10 power line cycles per sample by pressing **NPLC 1 0 Enter**.
- b. Program 100 samples per trigger by pressing **N Rdgs/Trig 1 0 0 Enter**.
- c. Set up voltmeter to take measurements in the statistical mode as follows:
 Press **[] (shift key) f0 [] (shift key) N**.
 Press **[▲]** until MATH function is selected, then press **[▶]**.
 Press **[▲]** until STAT function is selected, then press **Enter**.
- d. Set up voltmeter to read the average of the measurements as follows:
 Press **[] (shift key) f1 [] (shift key) N**.
 Press **[▼]** until RMATH function is selected, then press **[▶]**.
 Press **[▲]** until MEAN function is selected, then press **Enter**.
- e. Execute the program by pressing **f0 Enter TRIG Enter**.
- f. Wait for 100 readings and then read the average measurement by pressing **f1 Enter**.
 To repeat the measurement, perform steps (e) and (f).

CC Load Effect

This test measures the change in output current for a change in the load from full scale output voltage to short circuit.

- a. Turn off the supply and connect the output as shown in Figure 2-1 with the DVM connected across the current monitoring resistor.

- b. Turn on the supply and program the current to the full scale current value and the output voltage to the maximum programmable voltage value (see Table 2-3).
- c. Adjust the load in the CV mode for full scale voltage as indicated on the front panel display. Check that the CC annunciator is on. If it is not, adjust the load so that the output voltage drops slightly.
- d. *Record the output current reading (DVM reading/current monitor resistance value in ohms).
- e. *Short the load switch and record the output current reading.

The difference in the current readings in steps (d) and (e) is the load effect and should not exceed the limit specified in the Performance Test Record Form for the appropriate model under CC LOAD EFFECT.

* You may want to use the average reading program described previously.

CC Source Effect

This test measures the change in output current that results when the AC line voltage changes from the minimum to the maximum value within the specifications.

- a. Turn off the supply and connect the AC power line through a variable voltage transformer.
- b. Connect the output terminals as shown in Figure 2-1 with the DVM connected across the current monitoring resistor. Set the transformer to the nominal line voltage.
- c. Turn on the supply and program the current to the full scale value and the output voltage to the maximum programmable value (see Table 2-3).
- d. Adjust the load in the CV mode for full scale voltage as indicated on the front panel display. Check that the CC annunciator is on. If it is not, adjust the load so that the output voltage drops slightly.
- e. Adjust the transformer to 13% below the nominal line voltage.
- f. *Record the output current reading (DVM reading/current monitoring resistor in ohms).
- g. Adjust the transformer to 6% above the nominal line voltage.
- h. *Record the output current reading again.

The difference in the current readings in steps (f) and (h) is the CC source effect and should not exceed the values listed in the Performance Test Record Form for the appropriate model under CC SOURCE EFFECT.

*You may want to use the average reading program described previously.

CC Noise (PARD)

Periodic and random deviations (PARD) in the output (ripple and noise) combine to produce a residual AC current, as well, as an AC voltage superimposed on the DC output. Constant current (CC) PARD is specified as the rms output current in a frequency range 20 Hz to 20 MHz with the supply in CC operation.

- a. Turn off the supply and connect the load resistor and rms voltmeter as shown in Figure 2-3. Leads should be as short as possible to reduce noise pick-up. Use only a resistive load for this test.
- b. Check the test setup for noise with the supply turned off. Other equipment (e.g. computer, DMM, etc.) may affect the reading.
- c. Turn on the supply and program the current to full scale and the output voltage to the maximum programmable value (see Table 2-3).
- d. The output current should be at the full scale rating with the CC annunciator on.
- e. Divide the reading on the rms voltmeter by the load resistance to obtain rms current. It should not exceed the values listed in the Performance Test Record Form for the appropriate model under CC NOISE (RMS).

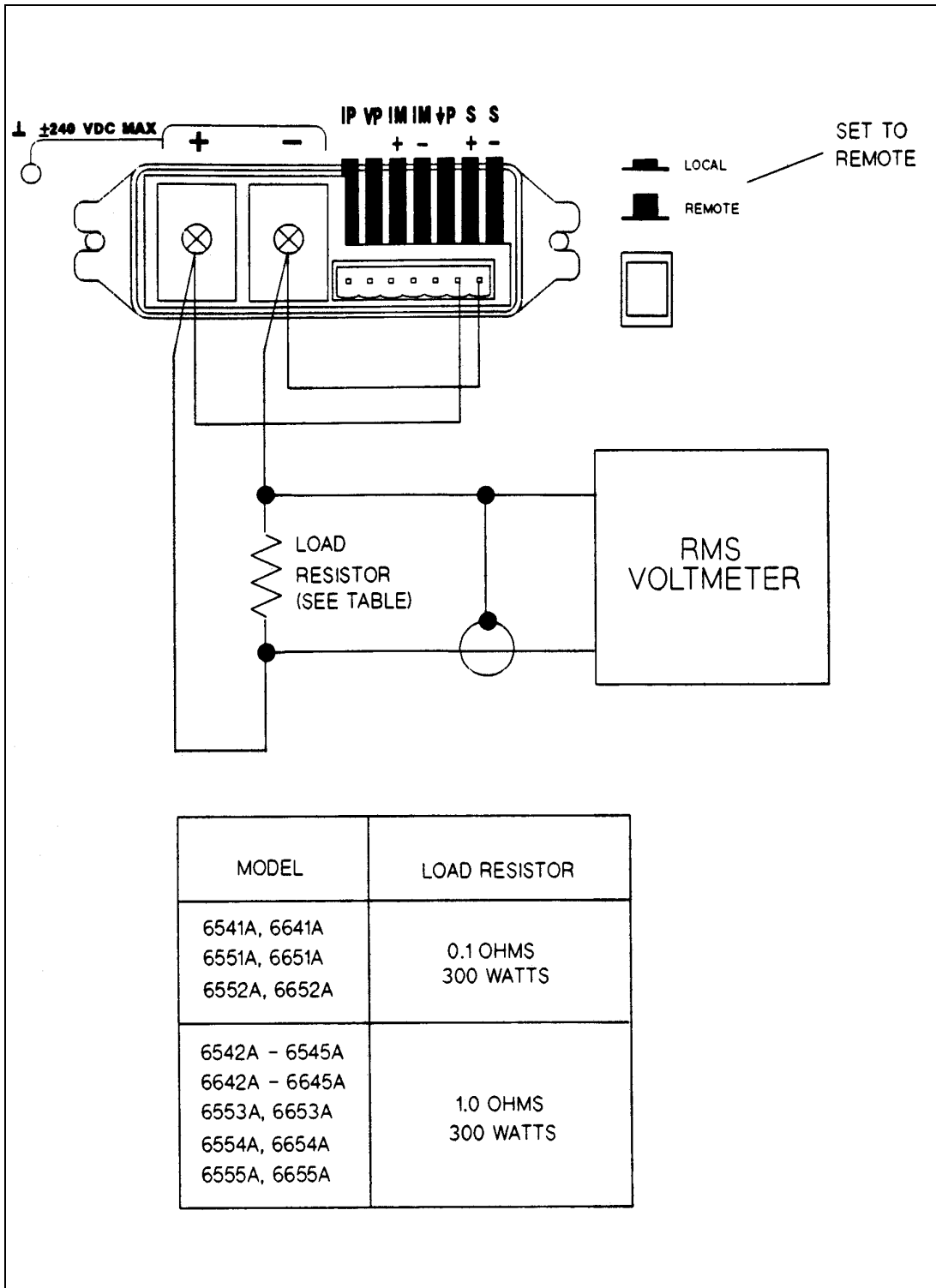

Figure 2-3. CC RMS Noise Measurement Test Setup

Table 2-4. Performance Test Record Form

Test Facility:

_____	Report No. _____
_____	Date _____
_____	Customer _____
_____	Tested By _____
Model _____	Ambient Temperature _____
Serial No. _____	Relative Humidity _____
Options _____	Nominal Line Frequency (Hz) _____
Firmware Revision _____	

Special Notes:

Test Equipment Used:

Description	Model No.	Trace No.	Cal. Due Date
1. AC Source	_____	_____	_____
2. DC Voltmeter	_____	_____	_____
3. RMS Voltmeter	_____	_____	_____
4. Oscilloscope	_____	_____	_____
5. Electronic Load	_____	_____	_____
6. Current Monitoring Shunt	_____	_____	_____

Table 2-5. Performance Test Record for Keysight Model 6541A or 6641A

MODEL Keysight _____	Report No. _____		Date _____	
Test Description	Minimum Spec.	Results *	Maximum Spec.	Measurement Uncertainty
Constant Voltage Tests				
Voltage Programming and Readback				
Low Voltage (0 V) V_{out} Front Panel Display Readback	-5 mV $V_{out} - 6$ mV	_____mV _____mV	+5 mV $V_{out} + 6$ mV	2 μ V 2 μ V
High Voltage (8 V) V_{out} Front Panel Display Readback	7.990 V $V_{out} - 11.6$ mV	_____V _____mV	8.010 V $V_{out} + 11.6$ mV	88 μ V 88 μ V
Load Effect	$V_{out} - 1$ mV	_____mV	$V_{out} + 1$ mV	1 μ V
Source Effect	$V_{out} - 0.5$ mV	_____mV	$V_{out} + 0.5$ mV	1 μ V
PARD (Ripple and Noise)				
Peak-to-Peak	0	_____mV	3 mV	384 μ V
RMS	0	_____ μ V	300 μ V	50 μ V
Transient Response Time (at 100 μs)	0	_____mV	20 mV	4 mV
Constant Current Tests				
Current Programming and Readback				
Low Current (0 A) I_{out} Front Panel Display Readback	-26 mA $I_{out} - 18$ mA	_____mA _____mA	+26 mA $I_{out} + 18$ mA	153 μ A 153 μ A
High Current (20 A) I_{out} Front Panel Display Readback	19.944 A $I_{out} - 48$ mA	_____A _____mA	+20.056 A $I_{out} + 48$ mA	2.7 mA 2.7 mA
Current Sink (5.8 A) Display Readback	$I_{sink} - 60$ mA	_____mA	$I_{sink} + 60$ mA	2.4 mA
PARD (Ripple and Noise) RMS	0	_____mA	10 mA	2 mA
Load Effect	$I_{out} - 1$ mA	_____mA	$I_{out} + 1$ mA	16 μ A
Source Effect	$I_{out} - 1$ mA	_____mA	$I_{out} + 1$ mA	16 μ A
*Enter your test results in this column.				

Table 2-6. Performance Test Record for Keysight Model 6542A or 6642A

MODEL Keysight _____	Report No. _____		Date _____	
Test Description	Minimum Spec.	Results *	Maximum Spec.	Measurement Uncertainty
Constant Voltage Tests				
Voltage Programming and Readback				
Low Voltage (0 V) V_{out} Front Panel Display Readback	-10 mV $V_{out} - 15$ mV	_____mV _____mV	+10 mV $V_{out} + 15$ mV	2 μ V 2 μ V
High Voltage (20 V) V_{out} Front Panel Display Readback	19.978 V $V_{out} - 29$ mV	_____V _____mV	20.022 V $V_{out} + 29$ mV	335 μ V 335 μ V
Load Effect	$V_{out} - 2$ mV	_____mV	$V_{out} + 2$ mV	20 μ V
Source Effect	$V_{out} - 0.5$ mV	_____mV	$V_{out} + 0.5$ mV	20 μ V
PARD (Ripple and Noise)				
Peak-to-Peak	0	_____mV	3 mV	384 μ V
RMS	0	_____ μ V	300 μ V	50 μ V
Transient Response Time (at 100 μs)	0	_____mV	20 mV	4 mV
Constant Current Tests				
Current Programming and Readback				
Low Current (0 A) I_{out} Front Panel Display Readback	-13 mA $I_{out} - 9.1$ mA	_____mA _____mA	+13 mA $I_{out} + 9.1$ mA	20 μ A 20 μ A
High Current (10 A) I_{out} Front Panel Display Readback	9.972 A $I_{out} - 24.1$ mA	_____A _____mA	+10.028 A $I_{out} + 24.1$ mA	3.1 mA 3.1 mA
Current Sink (2.5 A) Display Readback	$I_{sink} - 29$ mA	_____mA	$I_{sink} + 29$ mA	1 mA
PARD (Ripple and Noise)				
RMS	0	_____mA	5 mA	750 μ A
Load Effect	$I_{out} - 0.5$ mA	_____mA	$I_{out} + 0.5$ mA	4 μ A
Source Effect	$I_{out} - 0.5$ mA	_____mA	$I_{out} + 0.5$ mA	4 μ A
*Enter your test results in this column.				

Table 2-7. Performance Test Record for Keysight Model 6543A or 6643A

MODEL Keysight _____	Report No. _____		Date _____	
Test Description	Minimum Spec.	Results *	Maximum Spec.	Measurement Uncertainty
Constant Voltage Tests				
Voltage Programming and Readback				
Low Voltage (0 V) V_{out} Front Panel Display Readback	-15 mV $V_{out} - 25$ mV	_____mV _____mV	+15 mV $V_{out} + 25$ mV	2 μ V 2 μ V
High Voltage (35 V) V_{out} Front Panel Display Readback	34.964 V $V_{out} - 50$ mV	_____V _____mV	35.036 V $V_{out} + 50$ mV	525 μ V 525 μ V
Load Effect	$V_{out} - 3$ mV	_____mV	$V_{out} + 3$ mV	27 μ V
Source Effect	$V_{out} - 1$ mV	_____mV	$V_{out} + 1$ mV	27 μ V
PARD (Ripple and Noise)				
Peak-to-Peak	0	_____mV	4 mV	384 μ V
RMS	0	_____ μ V	400 μ V	50 μ V
Transient Response Time (at 100 μs)	0	_____mV	35 mV	8 mV
Constant Current Tests				
Current Programming and Readback				
Low Current (0 A) I_{out} Front Panel Display Readback	-6.7 mA $I_{out} - 5$ mA	_____mA _____mA	+6.7 mA $I_{out} + 5$ mA	16 μ A 16 μ A
High Current (6 A) I_{out} Front Panel Display Readback	5.985 A $I_{out} - 14$ mA	_____A _____mA	+6.015 A $I_{out} + 14$ mA	1.1 mA 1.1 mA
Current Sink (1.5 A) Display Readback	$I_{sink} - 17$ mA	_____mA	$I_{sink} + 17$ mA	630 μ A
PARD (Ripple and Noise)				
RMS	0	_____mA	3 mA	650 μ A
Load Effect	$I_{out} - 0.25$ mA	_____mA	$I_{out} + 0.25$ mA	3 μ A
Source Effect	$I_{out} - 0.25$ mA	_____mA	$I_{out} + 0.25$ mA	3 μ A
*Enter your test results in this column.				

Table 2-8. Performance Test Record for Keysight Model 6544A or 6644A

MODEL Keysight _____	Report No. _____		Date _____	
Test Description	Minimum Spec.	Results *	Maximum Spec.	Measurement Uncertainty
Constant Voltage Tests				
Voltage Programming and Readback				
Low Voltage (0 V) V_{out} Front Panel Display Readback	-26 mV $V_{out} - 40$ mV	_____mV _____mV	+26 mV $V_{out} + 40$ mV	2 μ V 2 μ V
High Voltage (60 V) V_{out} Front Panel Display Readback	59.938 V $V_{out} - 82$ mV	_____V _____mV	60.062 V $V_{out} + 82$ mV	845 μ V 845 μ V
Load Effect	$V_{out} - 4$ mV	_____mV	$V_{out} + 4$ mV	40 μ V
Source Effect	$V_{out} - 1$ mV	_____mV	$V_{out} + 1$ mV	40 μ V
PARD (Ripple and Noise)				
Peak-to-Peak	0	_____mV	5 mV	384 μ V
RMS	0	_____ μ V	500 μ V	50 μ V
Transient Response Time (at 100 μs)	0	_____mV	60 mV	13 mV
Constant Current Tests				
Current Programming and Readback				
Low Current (0 A) I_{out} Front Panel Display Readback	-4.1 mA $I_{out} - 3$ mA	_____mA _____mA	+4.1 mA $I_{out} + 3$ mA	16 μ A 16 μ A
High Current (3.5 A) I_{out} Front Panel Display Readback	3.491 A $I_{out} - 8.3$ mA	_____A _____mA	+3.509 A $I_{out} + 8.3$ mA	500 μ A 500 μ A
Current Sink (0.9 A) Display Readback	$I_{sink} - 3.15$ mA	_____mA	$I_{sink} + 3.15$ mA	386 μ A
PARD (Ripple and Noise)				
RMS	0	_____mA	1.5 mA	225 μ A
Load Effect	$I_{out} - 0.25$ mA	_____mA	$I_{out} + 0.25$ mA	2 μ A
Source Effect	$I_{out} - 0.25$ mA	_____mA	$I_{out} + 0.25$ mA	2 μ A
*Enter your test results in this column.				

Table 2-9. Performance Test Record for Keysight Model 6545A or 6645A

MODEL Keysight _____	Report No. _____		Date _____	
Test Description	Minimum Spec.	Results *	Maximum Spec.	Measurement Uncertainty
Constant Voltage Tests				
Voltage Programming and Readback				
Low Voltage (0 V) V_{out} Front Panel Display Readback	-51 mV $V_{out} - 80$ mV	_____mV _____mV	+51 mV $V_{out} + 80$ mV	2 μ V 2 μ V
High Voltage (120 V) V_{out} Front Panel Display Readback	119.877 V $V_{out} - 164$ mV	_____V _____mV	120.123 V $V_{out} + 164$ mV	1.7 mV 1.7 mV
Load Effect	$V_{out} - 5$ mV	_____mV	$V_{out} + 5$ mV	230 μ V
Source Effect	$V_{out} - 2$ mV	_____mV	$V_{out} + 2$ mV	230 μ V
PARD (Ripple and Noise)				
Peak-to-Peak	0	_____mV	7 mV	384 μ V
RMS	0	_____ μ V	700 μ V	50 μ V
Transient Response Time (at 100 μs)	0	_____mV	120 mV	27 mV
Constant Current Tests				
Current Programming and Readback				
Low Current (0 A) I_{out} Front Panel Display Readback	-1.7 mA $I_{out} - 1.3$ mA	_____mA _____mA	+1.7 mA $I_{out} + 1.3$ mA	16 μ A 16 μ A
High Current (1.5 A) I_{out} Front Panel Display Readback	1.496 A $I_{out} - 3.5$ mA	_____A _____mA	+1.504 A $I_{out} + 3.5$ mA	188 μ A 188 μ A
Current Sink (0.75 A) Display Readback	$I_{sink} - 5.5$ mA	_____mA	$I_{sink} + 5.5$ mA	46 μ A
PARD (Ripple and Noise)				
RMS	0	_____mA	1 mA	200 μ A
Load Effect	$I_{out} - 0.25$ mA	_____mA	$I_{out} + 0.25$ mA	1.5 μ A
Source Effect	$I_{out} - 0.25$ mA	_____mA	$I_{out} + 0.25$ mA	1.5 μ A
*Enter your test results in this column.				

Table 2-10. Performance Test Record for Keysight Model 6551A or 6651A

MODEL Keysight _____	Report No. _____		Date _____	
Test Description	Minimum Spec.	Results *	Maximum Spec.	Measurement Uncertainty
Constant Voltage Tests				
Voltage Programming and Readback				
Low Voltage (0 V) V_{out} Front Panel Display Readback	-5 mV $V_{out} - 6$ mV	_____mV _____mV	+5 mV $V_{out} + 6$ mV	2 μ V 2 μ V
High Voltage (8 V) V_{out} Front Panel Display Readback	7.990 V $V_{out} - 11.6$ mV	_____V _____mV	8.010 V $V_{out} + 11.6$ mV	88 μ V 88 μ V
Load Effect	$V_{out} - 1$ mV	_____mV	$V_{out} + 1$ mV	1 μ V
Source Effect	$V_{out} - 0.5$ mV	_____mV	$V_{out} + 0.5$ mV	1 μ V
PARD (Ripple and Noise)				
Peak-to-Peak	0	_____mV	3 mV	384 μ V
RMS	0	_____ μ V	300 μ V	50 μ V
Transient Response Time (at 100 μs)	0	_____mV	20 mV	4 mV
Constant Current Tests				
Current Programming and Readback				
Low Current (0 A) I_{out} Front Panel Display Readback	-26 mA $I_{out} - 18$ mA	_____mA _____mA	+60 mA $I_{out} + 67$ mA	150 μ A 150 μ A
High Current (50 A) I_{out} Front Panel Display Readback	49.865 A $I_{out} - 142$ mA	_____A _____mA	+50.135 A $I_{out} + 142$ mA	10.7 mA 10.7 mA
Current Sink (10 A) Display Readback	$I_{sink} - 135$ mA	_____mA	$I_{sink} + 135$ mA	4.1 mA
PARD (Ripple and Noise)				
RMS	0	_____mA	25 mA	2.8 mA
Load Effect	$I_{out} - 2$ mA	_____mA	$I_{out} + 2$ mA	25 μ A
Source Effect	$I_{out} - 2$ mA	_____mA	$I_{out} + 2$ mA	25 μ A
*Enter your test results in this column.				

Table 2-11. Performance Test Record for Keysight Model 6552A or 6652A

MODEL Keysight _____	Report No. _____		Date _____	
Test Description	Minimum Spec.	Results *	Maximum Spec.	Measurement Uncertainty
Constant Voltage Tests				
Voltage Programming and Readback				
Low Voltage (0 V) V_{out} Front Panel Display Readback	-10 mV $V_{out} - 15$ mV	_____mV _____mV	+10 mV $V_{out} + 15$ mV	2 μ V 2 μ V
High Voltage (20 V) V_{out} Front Panel Display Readback	19.978 V $V_{out} - 29$ mV	_____V _____mV	20.022 V $V_{out} + 29$ mV	335 μ V 335 μ V
Load Effect	$V_{out} - 2$ mV	_____mV	$V_{out} + 2$ mV	20 μ V
Source Effect	$V_{out} - 0.5$ mV	_____mV	$V_{out} + 0.5$ mV	20 μ V
PARD (Ripple and Noise)				
Peak-to-Peak	0	_____mV	3 mV	384 μ V
RMS	0	_____ μ V	300 μ V	50 μ V
Transient Response Time (at 100 μs)	0	_____mV	20 mV	4 mV
Constant Current Tests				
Current Programming and Readback				
Low Current (0 A) I_{out} Front Panel Display Readback	-25 mA $I_{out} - 26$ mA	_____mA _____mA	+25 mA $I_{out} + 26$ mA	153 μ A 153 μ A
High Current (25 A) I_{out} Front Panel Display Readback	24.937 A $I_{out} - 63.5$ mA	_____A _____mA	+25.063 A $I_{out} + 63.5$ mA	3.5 mA 3.5 mA
Current Sink (5 A) Display Readback	$I_{sink} - 62$ mA	_____mA	$I_{sink} + 62$ mA	2.6 mA
PARD (Ripple and Noise)				
RMS	0	_____mA	10 mA	2 mA
Load Effect	$I_{out} - 1$ mA	_____mA	$I_{out} + 1$ mA	17.5 μ A
Source Effect	$I_{out} - 1$ mA	_____mA	$I_{out} + 1$ mA	17.5 μ A
*Enter your test results in this column.				

Table 2-12. Performance Test Record for Keysight Model 6553A or 6653A

MODEL Keysight _____	Report No. _____		Date _____	
Test Description	Minimum Spec.	Results *	Maximum Spec.	Measurement Uncertainty
Constant Voltage Tests				
Voltage Programming and Readback				
Low Voltage (0 V) V_{out} Front Panel Display Readback	-15 mV $V_{out} - 25$ mV	_____mV _____mV	+15 mV $V_{out} + 25$ mV	2 μ V 2 μ V
High Voltage (35 V) V_{out} Front Panel Display Readback	34.964 V $V_{out} - 50$ mV	_____V _____mV	35.036 V $V_{out} + 50$ mV	525 μ V 525 μ V
Load Effect	$V_{out} - 3$ mV	_____mV	$V_{out} + 3$ mV	27 μ V
Source Effect	$V_{out} - 1$ mV	_____mV	$V_{out} + 1$ mV	27 μ V
PARD (Ripple and Noise)				
Peak-to-Peak	0	_____mV	4 mV	384 μ V
RMS	0	_____ μ V	400 μ V	50 μ V
Transient Response Time (at 100 μs)	0	_____mV	35 mV	8 mV
Constant Current Tests				
Current Programming and Readback				
Low Current (0 A) I_{out} Front Panel Display Readback	-13 mA $I_{out} - 15$ mA	_____mA _____mA	+13 mA $I_{out} + 15$ mA	17 μ A 17 μ A
High Current (15 A) I_{out} Front Panel Display Readback	14.964 A $I_{out} - 37.5$ mA	_____A _____mA	+15.036 A $I_{out} + 37.5$ mA	6.2 mA 6.2 mA
Current Sink (3 A) Display Readback	$I_{sink} - 35$ mA	_____mA	$I_{sink} + 35$ mA	1.6 mA
PARD (Ripple and Noise)				
RMS	0	_____mA	5 mA	750 μ A
Load Effect	$I_{out} - 0.5$ mA	_____mA	$I_{out} + 0.5$ mA	5.8 μ A
Source Effect	$I_{out} - 0.75$ mA	_____mA	$I_{out} + 0.75$ mA	5.8 μ A
*Enter your test results in this column.				

Table 2-13. Performance Test Record for Keysight Model 6554A or 6654A

MODEL Keysight _____	Report No. _____		Date _____	
Test Description	Minimum Spec.	Results *	Maximum Spec.	Measurement Uncertainty
Constant Voltage Tests				
Voltage Programming and Readback				
Low Voltage (0 V) V_{out} Front Panel Display Readback	-26 mV $V_{out} - 40$ mV	_____mV _____mV	+26 mV $V_{out} + 40$ mV	2 μ V 2 μ V
High Voltage (60 V) V_{out} Front Panel Display Readback	59.938 V $V_{out} - 82$ mV	_____V _____mV	60.062 V $V_{out} + 82$ mV	845 μ V 845 μ V
Load Effect	$V_{out} - 4$ mV	_____mV	$V_{out} + 4$ mV	40 μ V
Source Effect	$V_{out} - 1$ mV	_____mV	$V_{out} + 1$ mV	40 μ V
PARD (Ripple and Noise)				
Peak-to-Peak	0	_____mV	5 mV	384 μ V
RMS	0	_____ μ V	500 μ V	50 μ V
Transient Response Time (at 100 μs)	0	_____mV	60 mV	13 mV
Constant Current Tests				
Current Programming and Readback				
Low Current (0 A) I_{out} Front Panel Display Readback	-8 mA $I_{out} - 7$ mA	_____mA _____mA	+8 mA $I_{out} + 7$ mA	16 μ A 16 μ A
High Current (9 A) I_{out} Front Panel Display Readback	8.978 A $I_{out} - 20.5$ mA	_____A _____mA	+9.022 A $I_{out} + 20.5$ mA	2.5 mA 2.5 mA
Current Sink (1.8 A) Display Readback	$I_{sink} - 21$ mA	_____mA	$I_{sink} + 21$ mA	1 mA
PARD (Ripple and Noise)				
RMS	0	_____mA	3 mA	650 μ A
Load Effect	$I_{out} - 0.5$ mA	_____mA	$I_{out} + 0.5$ mA	3.7 μ A
Source Effect	$I_{out} - 0.5$ mA	_____mA	$I_{out} + 0.5$ mA	3.7 μ A
*Enter your test results in this column.				

Table 2-14. Performance Test Record for Keysight Model 6555A or 6655A

MODEL Keysight _____	Report No. _____		Date _____	
Test Description	Minimum Spec.	Results *	Maximum Spec.	Measurement Uncertainty
Constant Voltage Tests				
Voltage Programming and Readback				
Low Voltage (0 V) V_{out} Front Panel Display Readback	-51 mV $V_{out} - 80$ mV	_____mV _____mV	+51 mV $V_{out} + 80$ mV	2 μ V 2 μ V
High Voltage (120 V) V_{out} Front Panel Display Readback	119.877 V $V_{out} - 164$ mV	_____V _____mV	120.123 V $V_{out} + 164$ mV	1.7 mV 1.7 mV
Load Effect	$V_{out} - 5$ mV	_____mV	$V_{out} + 5$ mV	230 μ V
Source Effect	$V_{out} - 2$ mV	_____mV	$V_{out} + 2$ mV	230 μ V
PARD (Ripple and Noise)				
Peak-to-Peak	0	_____mV	7 mV	384 μ V
RMS	0	_____ μ V	700 μ V	50 μ V
Transient Response Time (at 100 μs)	0	_____mV	120 mV	27 mV
Constant Current Tests				
Current Programming and Readback				
Low Current (0 A) I_{out} Front Panel Display Readback	- 4 mA $I_{out} - 3$ mA	_____mA _____mA	+4 mA $I_{out} + 3$ mA	15 μ A 15 μ A
High Current (4 A) I_{out} Front Panel Display Readback	3.990 A $I_{out} - 9$ mA	_____A _____mA	+4.010 A $I_{out} + 9$ mA	586 μ A 586 μ A
Current Sink (0.8 A) Display Readback	$I_{sink} -9.8$ mA	_____mA	$I_{sink} +9.8$ mA	350 μ A
PARD (Ripple and Noise)				
RMS	0	_____mA	2 mA	250 μ A
Load Effect	$I_{out} - 0.5$ mA	_____mA	$I_{out} + 0.5$ mA	2 μ A
Source Effect	$I_{out} - 0.5$ mA	_____mA	$I_{out} + 0.5$ mA	2 μ A
*Enter your test results in this column.				

Troubleshooting

WARNING

SHOCK HAZARD. Most of the troubleshooting procedures given in this chapter are performed with power applied and protective covers removed. Such maintenance should be performed only by service trained personnel who are aware of the hazards (for example, fire and electrical shock).

CAUTION

This instrument uses components which can either be damaged or suffer serious performance degradation as a result of ESD (electrostatic discharge). Observe the standard antistatic precautions to avoid damage to the components. An ESD summary is given in Chapter 1.

Introduction

This chapter provides troubleshooting and repair information for the power supply. Before attempting to troubleshoot the power supply, first check that the problem is with the supply itself and not with an associated circuit. The verification tests in Chapter 2 enable you to isolate a problem to the power supply.

Troubleshooting procedures are provided to isolate a problem to one of the circuit boards or a particular circuit. Figure 3-1 shows the location of the circuit boards and other chassis mounted components within the power supply. Once a problem has been isolated to a circuit board, additional troubleshooting procedures are available to isolate the problem to the defective component(s). Disassembly procedures are provided at the end of this chapter and should be referred to, as required, in order to gain access to and/or replace defective components.

If a component is defective, replace it and then conduct the verification test given in Chapter 2.

Note

Note that, when certain components are replaced, the supply must be re-calibrated (see "Post Repair Calibration" later in this chapter). If the EEPROM chip U6 on the A3 Front Panel Board is replaced, the supply must be initialized before it is re-calibrated. See "EEPROM Initialization" later in this chapter.

Chapter 5 in this manual lists all of the replaceable parts for the different Keysight series of power supplies. Chapter 6 contains schematics, test point measurements, and component location diagrams to aid you in troubleshooting the supply.

Test Equipment Required

Table 3-1 lists the test equipment required to troubleshoot the power supply. Recommended models are listed.

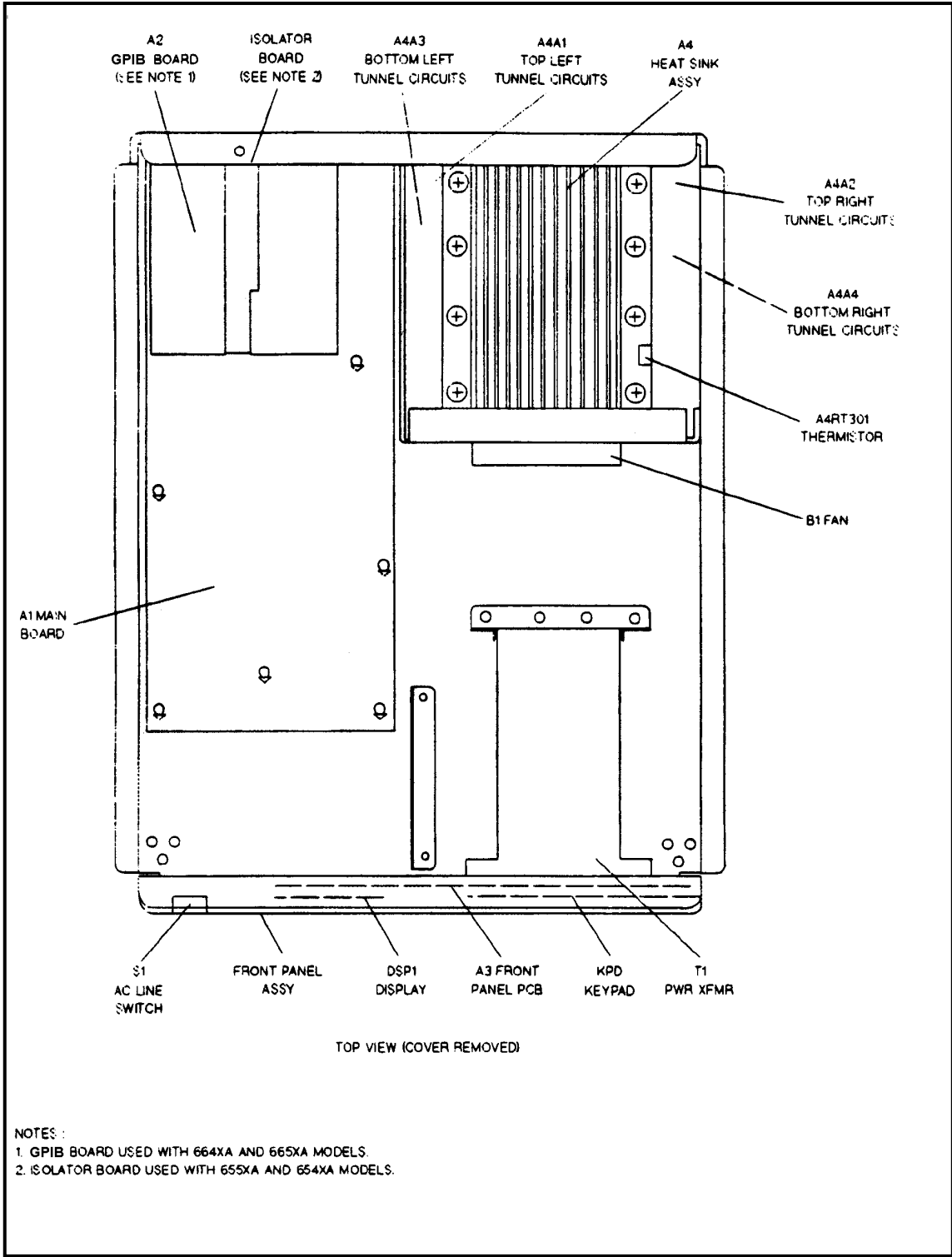

Figure 3-1. Top View with Cover Removed for 655xA & 665xA Models, (Sheet 1 of 2)

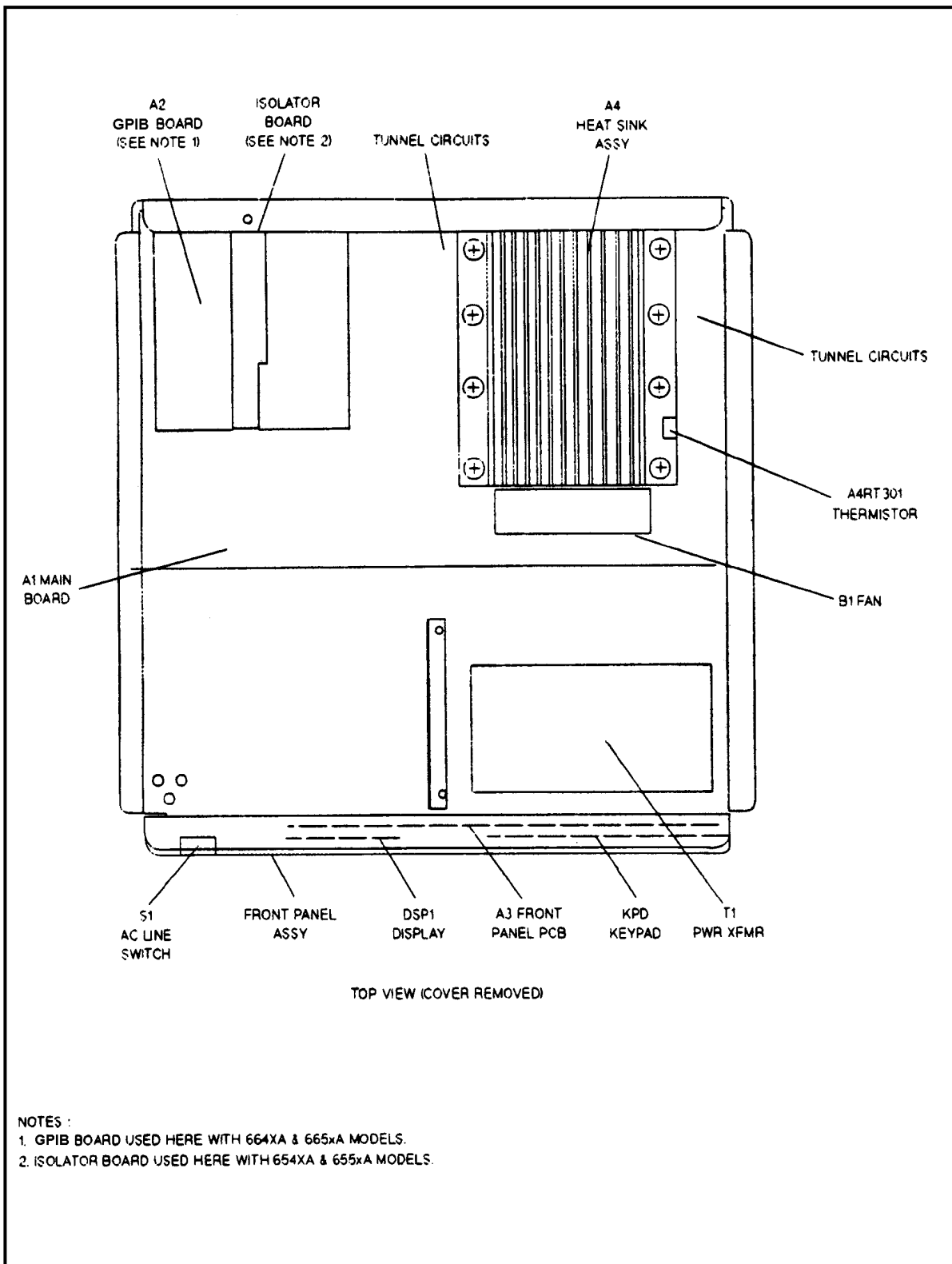

Figure 3-1. Top View with Cover Removed for 655xA & 665xA Models, (Sheet 2 of 2)

Table 3-1 Test Equipment Required for Troubleshooting

Type	Purpose	Recommended Model
GPIB Controller (used only with models 664xA & 665xA).	To communicate with the supply via the GPIB interface.	HP Series 200/300
Signature Analyzer	To troubleshoot most of the primary and secondary interface circuits	Keysight 5005 A/B
Digital Voltmeter	To check various voltage levels.	Keysight 3458A
Logic Probe	To check data lines.	Keysight 545A
Oscilloscope	To check wave forms and signal levels.	Keysight 54504A/54111A
IC Test Clips	To access IC pins.	AP Products No. LTC
Ammeter/Current Shunt	To measure output current.	

Overall Troubleshooting

Overall troubleshooting procedures for the power supply are given in the flow chart of Figure 3-2. The procedures first check that neither an AC input, nor a bias supply failure is causing the problem and that the supply passes the turn-on self test (no error messages). The normal turn-on, self-test indications are described in the "Power-on Checkout" paragraph in Chapter 3 of the Operating Manual.

If the supply passes the self test, Figure 3-2 directs you to perform the verification procedures in Chapter 2 from the front panel to determine if any functions are not calibrated or are not operating properly. For models 664xA & 665xA, the verification tests will also check to see if the supply can be programmed from a GPIB controller. If the supply fails any of the tests, you are directed to the applicable troubleshooting procedure or flow chart. Signature analysis (SA) is used to troubleshoot some of the supply's digital circuits.

Power-On Self-Test

The power-on, self-test sequence consists of tests of the front panel, primary GPIB interface (for 664xA & 665xA Models only), secondary interface circuits, and the isolator board (for 654xA & 655xA models). If the supply fails the self test, the output will remain disabled (turned off) and the front panel display should indicate the type of failure. The error will be displayed indefinitely and the supply will not accept GPIB or front panel commands.

Note that in order to perform troubleshooting procedures that require you to program the supply, you will have to disable the self test. You can do this by turning the supply off after it has failed the self test, and by holding down the "7" key on the front panel for two seconds while turning the unit on. This will cause the supply to skip the power-on self test. Table 3-2 lists the self test error messages that can appear on the display and gives the probable cause for each error.

Note For models 664xA & 665xA, a partial self test is performed when the *TST? query is executed (see Table 3-2). Those tests that interfere with normal interface operation or cause the output to change are not performed by *TST?. The return value of *TST? will be zero if all tests pass, or the error code of the first test that failed. The supply will not display error codes and will continue to attempt normal operation if *TST? returns a nonzero value.

Signature Analysis

The easiest and most efficient method of troubleshooting microprocessor based instruments is signature analysis (SA).

The SA technique is similar to signal tracing with an oscilloscope in linear circuits. Part of the microprocessor memory is dedicated to signature analysis and a known bit stream is generated to stimulate as many nodes as possible within a circuit. However, because it is virtually impossible to analyze a bit stream with an oscilloscope, a signature analyzer is used to compress the bit stream into a four character signature. By comparing the signatures of the IC under test to the correct signatures for each node, faults can be isolated to one or two components.

Signature analysis tests are provided for some of the digital circuits on the front panel board, the secondary interface circuits on the main circuit board, and for models 664xA & 665xA, the GPIB (primary interface) board. The GPIB primary interface SA tests are given in Table 3-3, SA tests for the front panel are given in Table 3-4, and the secondary interface SA tests are given in Table 3-5.

References are made to the appropriate SA table from the troubleshooting flow charts or procedures. The following general rules apply to signature analysis testing.

1. Be sure to use the correct test setup connections for the specific test.
2. Note the signatures for Vcc (+ 5 V) and common on the IC being examined. If an incorrect signature is the same as that of Vcc or common, that pin (or point in the circuit) is probably shorted to Vcc or ground.
3. If two pins have identical signatures, they are probably shorted together.
4. If two signatures are similar, it is only a coincidence.
5. If a signature is incorrect at an input pin, but is correct at its source (e.g., output of previous IC), check for printed circuit track or soldering problems.
6. An incorrect signature at an output could be caused by a faulty component producing the output. It can also be caused by an input short circuit in another component on the board.

Note	After completing an SA test, you must exit the SA mode by turning off power and performing a power-on reset.
-------------	--

Table 3-2 Self Test Error Codes/Messages

Code/Message	Description	Probable Cause
E1 FP RAM	Front panel RAM test failed (power-on).	Microprocessor A3U3 defective.
E2 FP ROM	Front panel ROM test failed (power-on, and for models 664xA & 665xA, also *TST?).	ROM A3U4 or address latches A3U8 defective.
E3 EE CHKSM	Front panel EEPROM checksum test failed (power-on, and for models 664xA & 665xA, also *TST?).	Possibly due to power loss during a write operation. See Checksum Error Recovery in the Operating Manual. If power loss is not the problem, EEPROM A3U6 could be defective (after replacing U6, supply must be initialized and calibrated).
The following four items (E4-E7) apply only to Keysight models 664xA & 665xA supplies.		
E4 PRI XRAM	Primary interface external RAM test failed (power-on).	RAM A2U108 defective.
E5 PRI IRAM	Primary interface internal RAM test failed (power-on).	Microprocessor A2U114 defective.
E6 PRI ROM	Primary interface ROM test failed (power-on, and for models 664xA & 665xA, also *TST?).	ROM A2U106 defective.
E7 GPIB	GPIB interface test failed (power-on).	Talker/listener chip A2U117 defective.
E8 SEC RAM	Secondary interface RAM test failed (power-on).	Microprocessor AIU504 defective.
E9 SEC ROM	Secondary interface ROM test failed (power-on, and for models 664xA & 665xA, also *TST?).	Microprocessor AIU504 defective.
E10 SEC 5 V	Secondary interface 5 volt read back test failed (power-on, and for models 664xA & 665xA, also *TST?).	Comparators AIU513, read back DAC AIU511/U512, or secondary bias supply defective.
E11 TEMP	Ambient temperature read back test failed power-on, and for models 664xA & 665xA, also *TST?).	Thermistor AIRT770 or comparator AIU513 defective
E12 DACS	CV or CC DAC tests failed (power-on).	CV DAC AIU507/U508 or CC DAC AIU509/U510 defective (see Figure 3-10).
Note: The following error messages can appear due to a failure occurring either while the power supply is operating or during the self test.		
SERIAL TIMEOUT	Serial data line failure on GPIB or isolator board.	See Figure 3-13.
SERIAL DOWN	Serial data line failure on GPIB or isolator board.	See Figure 3-13.
UART PARITY	UART failed.	UART chip A2U112 defective.
UART FRAMING	UART failed.	UART chip A2U112 defective.
UART OVERRUN	UART failed.	UART chip A2U112 defective.
SBUF OVERRUN	Serial buffer failure.	UART chip A2U112 defective or GPIB board is in SA mode.
SBUF FULL	Serial buffer failure.	UART chip A2U112 defective or GPIB board is in SA mode.
EE WRITE ERR	EEPROM write failure.	EEPROM A3U6 defective or calibration error.
SECONDARY DN	Serial data line failure on main board or isolator board.	See Figure 3-14.

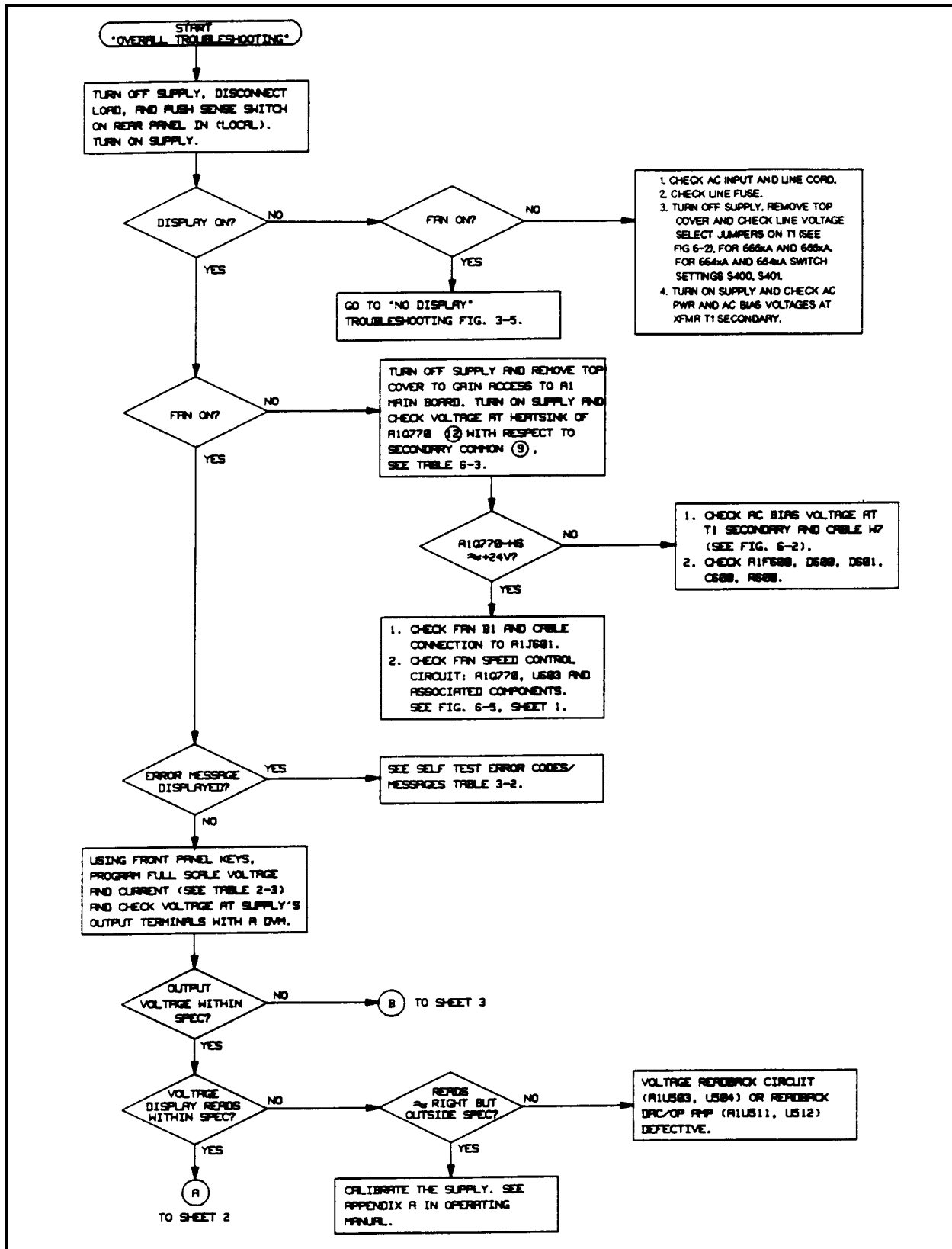

Figure 3-2. Overall Troubleshooting Flow Diagram (Sheet 1 of 4)

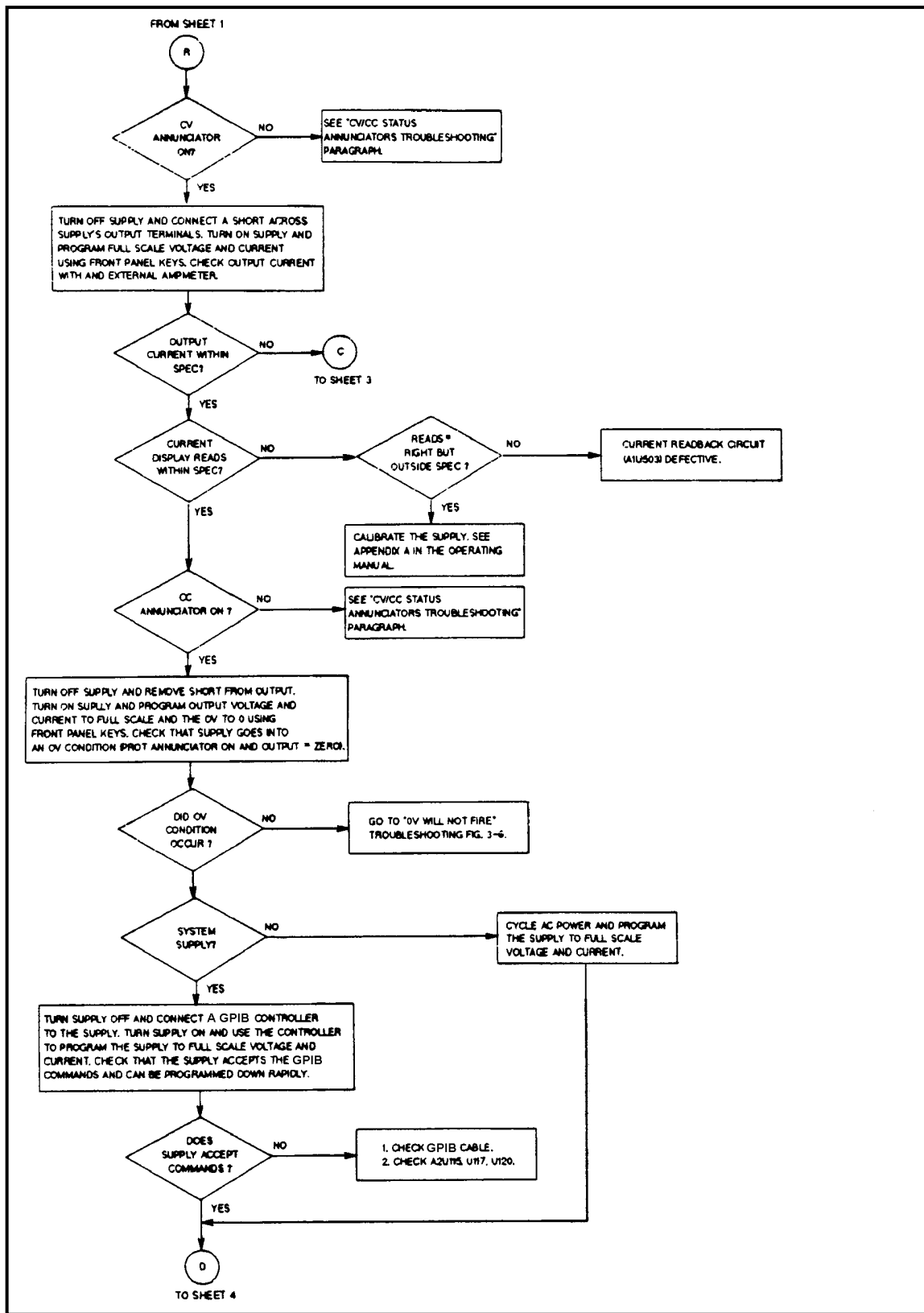

Figure 3-2. Overall Troubleshooting Flow Diagram (Sheet 2 of 4)

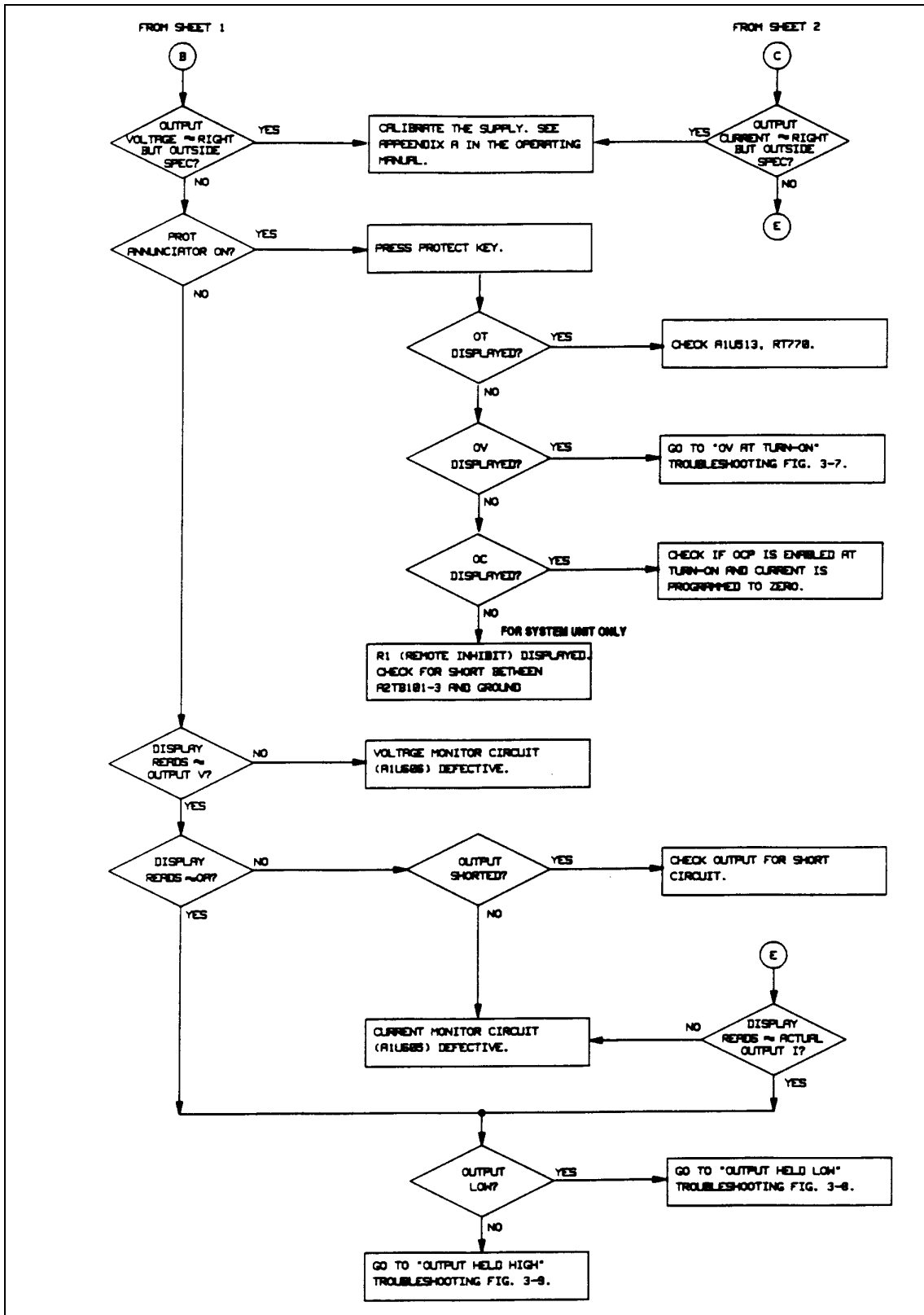

Figure 3-2. Overall Troubleshooting Flow Diagram (Sheet 3 of 4)

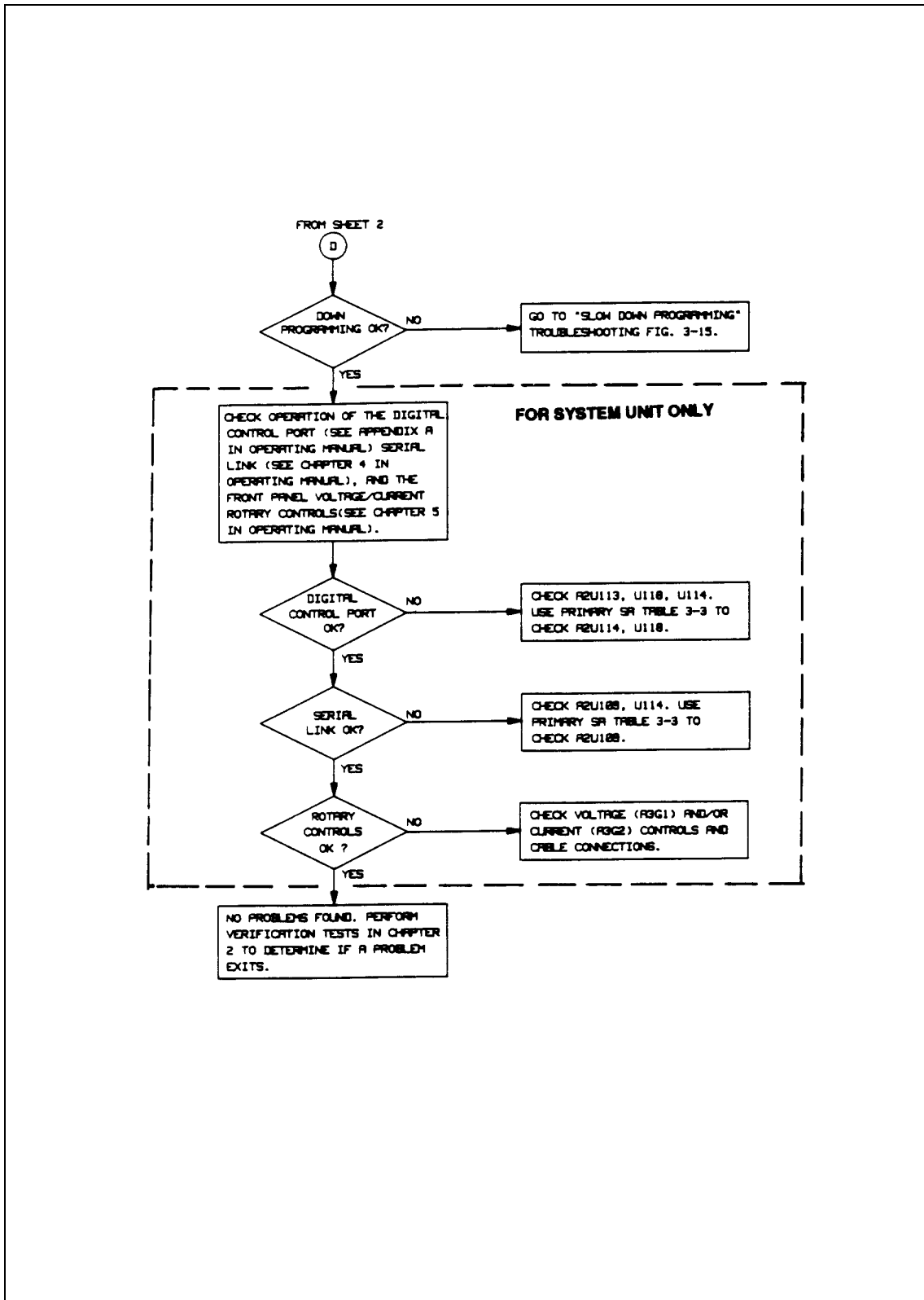

Figure 3-2. Overall Troubleshooting Flow Diagram (Sheet 4 of 4)

Firmware Revisions (for Models 664xA & 665xA)

You can use the *IDN? query to identify the revision of the supply's firmware. The query will readback the revisions of the primary ROM A2U106, the front panel ROM A3U4, and the secondary microprocessor AIU504. The manufacturer and model number of the supply are also returned. The following is a sample program:

```

10      ALLOCATE L$[52]
20      OUTPUT 705;"*IDN?"
30      ENTER 705;L$
40      DISP L$
50      END

```

The computer will display the manufacturer's name, the model number, a "0," and then the firmware revisions.

Example:"KEYSIGHT TECHNOLOGIES,6651A,0,fA.01.05sA.01.02pA.01.05"

where,

pA.01.05 is the primary interface (p) firmware revision (see Table 3-3).

fA.01.05 is the front panel (f) firmware revision (see Table 3-4).

sA.01.02 is the secondary interface (s) firmware revision (see Table 3-5).

For Keysight models 654xA & 655xA, the revision level of the ROMs can be found on the label affixed to the physical IC chip itself.

Test Headers

For Keysight models 664xA & 665xA, there are two test header connectors; A3J3 and A2J106. The A3J3 connector is located on the A3 front panel board and the A2J106 connector is located on the A2 GPIB board (see Figure 3-3). They are accessible when the top cover is removed from the supply. For models 654xA & 655xA, only the A3J3 test header is used.

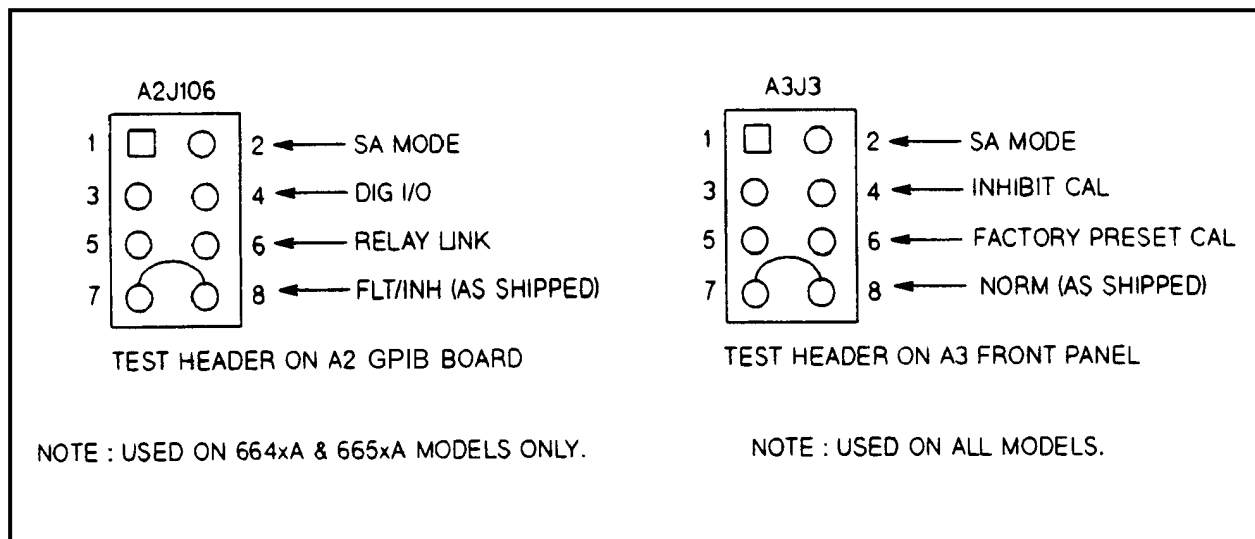

Figure 3-3. Test Header Jumper Positions

Front Panel Test Connector A3J3 Pins

1 and 2 (SA MODE)

Description

With these pins jumpered, the front panel is placed in the SA mode. Removing the jumper takes the front panel out of the SA mode.

3 and 4 (INHIBIT CAL)

With these pins jumpered, the power supply will ignore calibration commands, thus providing security against unauthorized calibration. With the jumper removed, the power supply will respond to calibration commands.

5 and 6 (FACTORY PRESET CAL)

With these pins jumpered, the power supply's calibration constants are set to their factory preset values. This can be useful if you have trouble calibrating the unit or if you forget the calibration password. See the "POST REPAIR CALIBRATION" discussion later in this chapter.

7 and 8 (NORM)

This is the normal operating/storage position for the jumper.

**Primary Interface Test Connector
A2J106 Pins, For Keysight Models 664xA
& 665xA Only****Description**

1 and 2 (SA MODE)

With these pins jumpered, the primary interface is placed in the SA mode. Removing this jumper takes the primary interface out of the SA mode.

3 and 4 (DIG I/O)

*With these pins jumpered, the supply's Digital Control (DIG CNTL) port is configured to be used with custom digital interface circuits.

5 and 6 (RELAY LINK)

*With these pins jumpered, the DIG CNTL port is configured to provide relay control outputs for relay accessories.

7 and 8 (FLT/INH)

*With these pins jumpered (as shipped from the factory), the DIG CNTL port is configured to provide a fault indicator (FLT) output and a remote inhibit (RI) input.

*See Appendix D in the Operating Manual for more information.

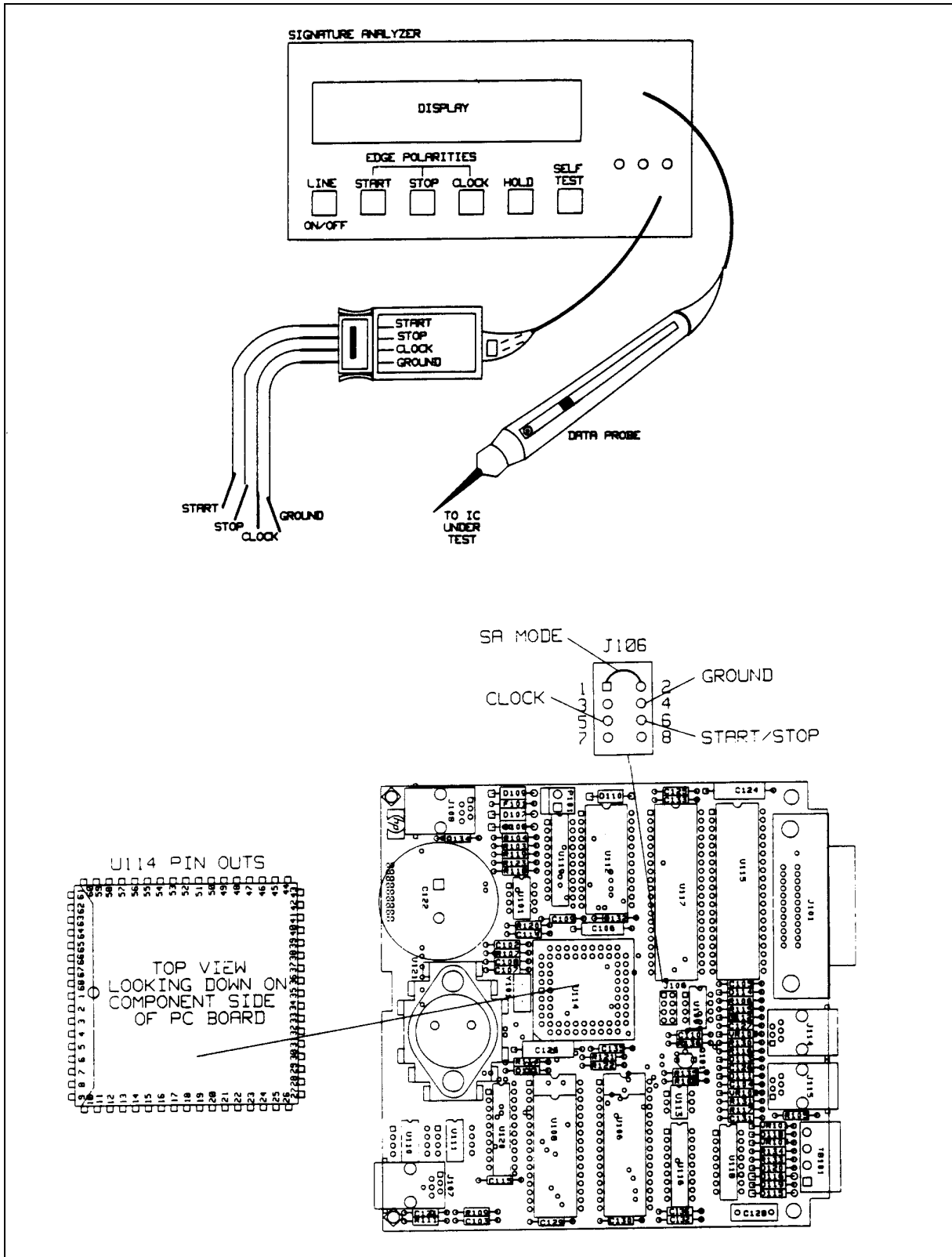

Figure 3-4. Connections For A2 GPIB Board Models 664xA & 665xA Only (Sheet 1 of 3)

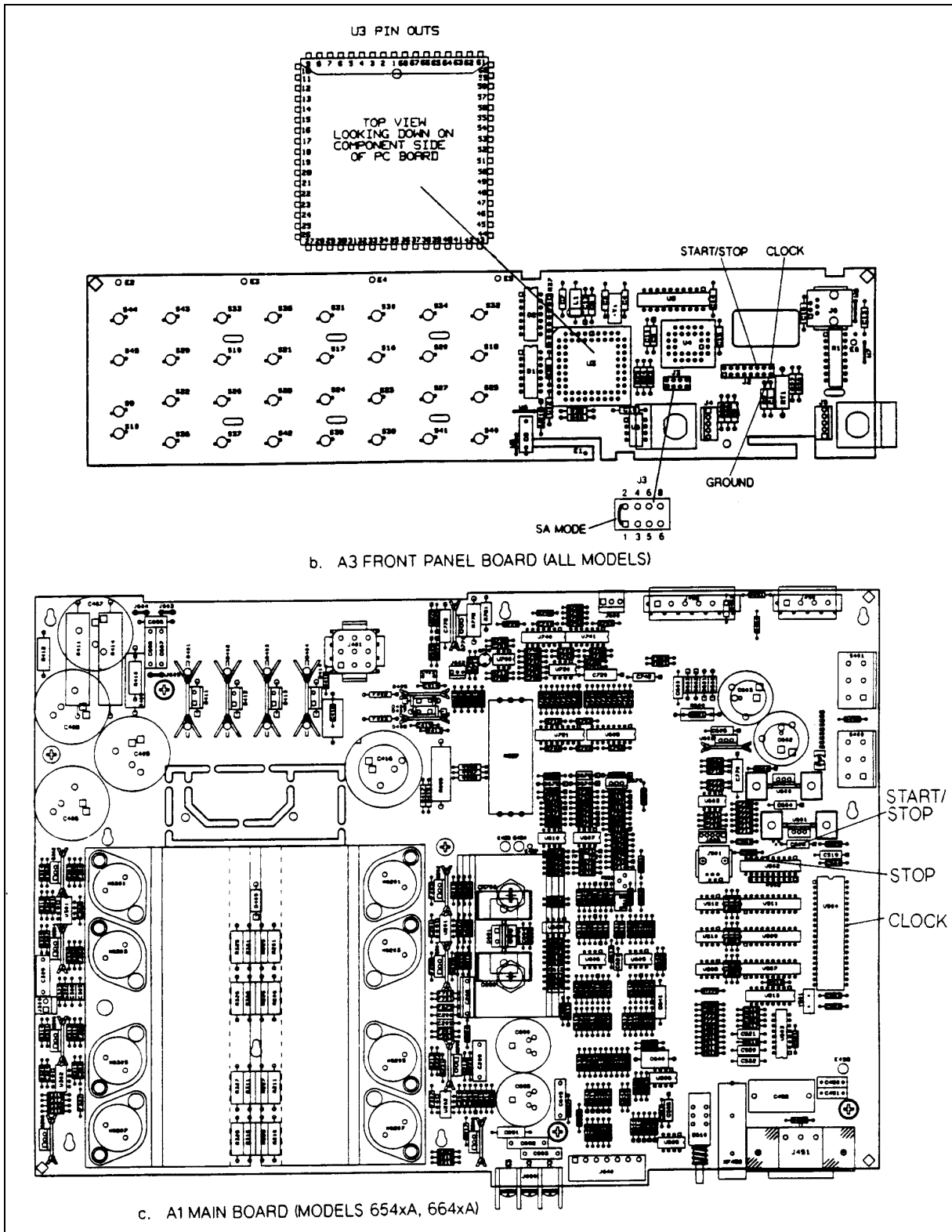

Figure 3-4. Connections For A2 GPIB Board Models 664xA & 665xA Only (Sheet 2 of 3)

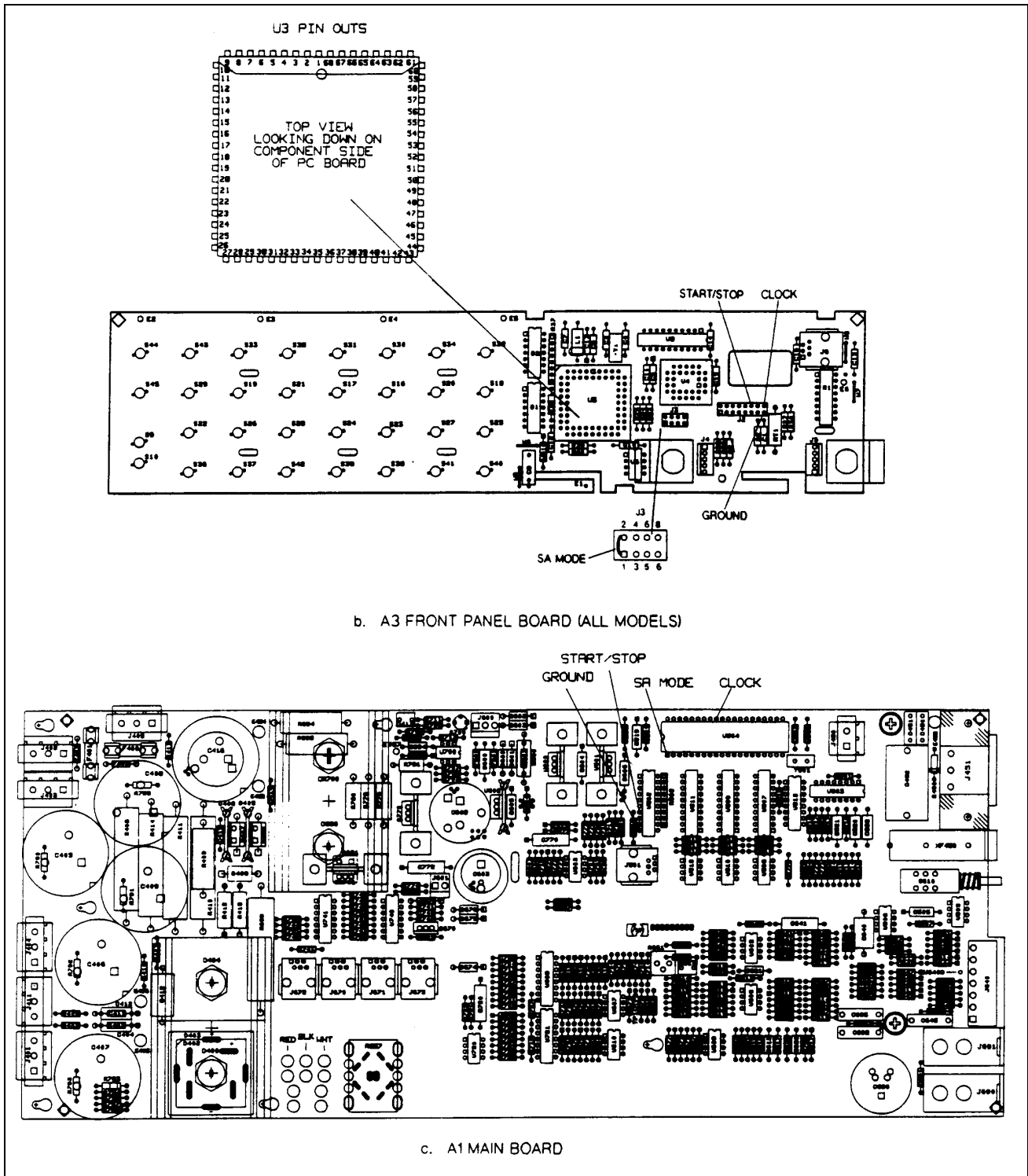

Figure 3-4. Connections For A2 GPIB Board Models 664xA & 665xA Only (Sheet 3 of 3)













Table 3-3. Primary Interface SA Test

<p>Description: These signatures check some primary interface circuits on the A2 GPIB Board.</p> <p>Valid A2U106 ROM Firmware Revision: A.01.06</p> <p>Test Setup: See Figure 3-4 Sheet 1.</p>		
<p>1. Turn off the power supply and remove the top cover.</p>		
<p>2. Connect SA jumper of connector J106 on A2 Keysight board to pins 1 and 2. Remember the original jumper position as you will need to restore the jumper to its original position after this test.</p>		
<p>3. Connect signature analyzer CLOCK, START, STOP, and GROUND inputs as shown below.</p>		
<p>Signature Analyzer Input</p>	<p>Edge Setting</p>	<p>A2 Board Connection</p>
<p>CLOCK</p>		<p>J106-5</p>
<p>START</p>		<p>J106-6</p>
<p>STOP</p>		<p>J106-6</p>
<p>GROUND</p>		<p>J106-4</p>
<p>4. Turn on the power supply and use the signature analyzer probe to take the following signatures:</p> <p>Power: 5 V = 9FFP</p> <p>Serial Link: A2U109-3 = 0104</p> <p>Microprocessor: A2U114-24 = 9FFP A2U114-25 = UF39</p> <p>Digital Control Interface: A2U118-1 = 9AFI A2U118-9 = 40A5 A2U118-10 = 1029 A2U118-15 = 0010 A2U118-16 = 040A</p> <p>Gated Array Logic: A2U119-2 = 0A55 A2U119-5 = 0040 A2U119-15 = 0040</p>		
<p>5. After completing the tests, be sure to return the J106 jumper to its original position.</p>		

Table 3-4. Front Panel SA Test

<p>Description: These signatures check microprocessor A3U3 on the front panel board.</p> <p>Valid A3U4 ROM Firmware Revision: A.01.07</p> <p>Test Setup: See Figure 3-4 Sheet 2 (for 200 Watt) or Sheet 3 (for 500 Watt) supplies.</p>																													
<p>1. Turn off the power supply and remove the top cover.</p>																													
<p>2. To gain access to A3 Front Panel Board, perform steps (a) and (b) of the disassembly procedure for Front Panel Assembly (See “Disassembly Procedures” later in this chapter).</p>																													
<p>3. Connect SA jumper between pins 1 and 2 of connector J3 on A3 Front Panel board. Remember the original jumper position as you will need to restore the jumper to its original position after this test.</p>																													
<p>4. Connect signature analyzer CLOCK, START, STOP, and GROUND inputs. Be sure to unplug the cable from J2 in order to access the connector pins.</p>																													
<p>Signature Analyzer Input</p> <p>CLOCK</p> <p>START</p> <p>STOP</p> <p>GROUND</p>	<p>Edge Setting</p>	<p>A3 Front Panel Board Connection</p> <p>*J2-9</p> <p>*J2-11</p> <p>*J2-11</p> <p>J3-J2-8</p>																											
<p>5. Turn on the power supply and use the signature analyzer probe to take the following signatures:</p> <table border="0" style="width: 100%;"> <tr> <td style="width: 30%;">Power:</td> <td colspan="2">5 V = 3395</td> </tr> <tr> <td rowspan="10">Microprocessor:</td> <td>A3U3-15 = 0000</td> <td>A3U3-29 = 1029</td> </tr> <tr> <td>A3U3-19 = 552U</td> <td>A3U3-30 = 0295</td> </tr> <tr> <td>A3U3-20= 954C</td> <td>A3U3-31 = 0000</td> </tr> <tr> <td>A3U3-21 = A552</td> <td>A3U3-32 = 3395</td> </tr> <tr> <td>A3U3-22= 2954</td> <td>A3U3-33= 0008</td> </tr> <tr> <td>A3U3-23 = 0A55</td> <td>A3U3-34 = 040A</td> </tr> <tr> <td>A3U3-24 = 3395</td> <td>A3U3-35 = 0102</td> </tr> <tr> <td>A3U3-25 = 3395</td> <td>A3U3-38 = 0002</td> </tr> <tr> <td>A3U3-26= 0000</td> <td>A3U3-39= 0020</td> </tr> <tr> <td>A3U3-27= 0000</td> <td>A3U3-42= 0000</td> </tr> <tr> <td></td> <td>A3U3-28 = 40A5</td> <td></td> </tr> </table>			Power:	5 V = 3395		Microprocessor:	A3U3-15 = 0000	A3U3-29 = 1029	A3U3-19 = 552U	A3U3-30 = 0295	A3U3-20= 954C	A3U3-31 = 0000	A3U3-21 = A552	A3U3-32 = 3395	A3U3-22= 2954	A3U3-33= 0008	A3U3-23 = 0A55	A3U3-34 = 040A	A3U3-24 = 3395	A3U3-35 = 0102	A3U3-25 = 3395	A3U3-38 = 0002	A3U3-26= 0000	A3U3-39= 0020	A3U3-27= 0000	A3U3-42= 0000		A3U3-28 = 40A5	
Power:	5 V = 3395																												
Microprocessor:	A3U3-15 = 0000	A3U3-29 = 1029																											
	A3U3-19 = 552U	A3U3-30 = 0295																											
	A3U3-20= 954C	A3U3-31 = 0000																											
	A3U3-21 = A552	A3U3-32 = 3395																											
	A3U3-22= 2954	A3U3-33= 0008																											
	A3U3-23 = 0A55	A3U3-34 = 040A																											
	A3U3-24 = 3395	A3U3-35 = 0102																											
	A3U3-25 = 3395	A3U3-38 = 0002																											
	A3U3-26= 0000	A3U3-39= 0020																											
	A3U3-27= 0000	A3U3-42= 0000																											
	A3U3-28 = 40A5																												
<p>6. After completing the test, be sure to return the J3 jumper to its original position.</p>																													

Table 3-5. Secondary Interface SA Test

<p>Description: These signatures check the secondary microprocessor AIU504.</p> <p>Valid AIU504 ROM Firmware Revision: A.01.03</p> <p>Test Setup: See Figure 3-4 either Sheet 2 or Sheet 3 as applicable to your model.</p>																																																																	
<p>1. Turn off the power supply and remove the top cover.</p>																																																																	
<p>2. Connect signature analyzer CLOCK, START, STOP, and GROUND inputs and setup as follows:</p> <table border="1"> <thead> <tr> <th>Signature Analyzer Input</th> <th>Edge Setting</th> <th>A1 Board Connection</th> </tr> </thead> <tbody> <tr> <td>CLOCK</td> <td></td> <td>U504-32</td> </tr> <tr> <td>START</td> <td></td> <td>U502-7</td> </tr> <tr> <td>STOP</td> <td></td> <td>U502-7</td> </tr> <tr> <td>GROUND</td> <td></td> <td>U502-10</td> </tr> </tbody> </table>			Signature Analyzer Input	Edge Setting	A1 Board Connection	CLOCK		U504-32	START		U502-7	STOP		U502-7	GROUND		U502-10																																																
Signature Analyzer Input	Edge Setting	A1 Board Connection																																																															
CLOCK		U504-32																																																															
START		U502-7																																																															
STOP		U502-7																																																															
GROUND		U502-10																																																															
<p>3. To place the secondary interface in the SA mode, turn on the power supply while momentarily (for 2 seconds) shorting AIU504-1 to AIU504-20 (common).</p>																																																																	
<p>4. Use the signature analyzer probe to take the following signatures:</p> <table> <tr> <td>Power:</td> <td colspan="2">5 V = 1C4C</td> </tr> <tr> <td>Microprocessor:</td> <td>AIU504-1 = F77H</td> <td>AIU504-21 = 5PC7</td> </tr> <tr> <td></td> <td>AIU504-2 = C98P</td> <td>AIU504-22 = 5PC7</td> </tr> <tr> <td></td> <td>AIU504-3 = 1573</td> <td>AIU504-23 = 5PC7</td> </tr> <tr> <td></td> <td>AIU504-4 = P42A</td> <td>AIU504-24 = 6CAP</td> </tr> <tr> <td></td> <td>AIU504-5 = UHF8</td> <td>AIU504-25 = A319</td> </tr> <tr> <td></td> <td>AIU504-6 = F5UC</td> <td>AIU504-26 = A319</td> </tr> <tr> <td></td> <td>AIU504-7 = UH8C</td> <td>AIU504-27 = A319</td> </tr> <tr> <td></td> <td>AIU504-8 = 23UC</td> <td>AIU504-28 = 5PC7</td> </tr> <tr> <td></td> <td>AIU504-9 = 0000</td> <td>AIU504-29 = 1C4C</td> </tr> <tr> <td></td> <td>AIU504-10 = 1C4C</td> <td>AIU504-30 = 0000</td> </tr> <tr> <td></td> <td>AIU504-11 = 1C4C</td> <td>AIU504-31 = 1C4C</td> </tr> <tr> <td></td> <td>AIU504-12 = C76F</td> <td>AIU504-32 = 0000</td> </tr> <tr> <td></td> <td>AIU504-13 = U042</td> <td>AIU504-33 = 0000</td> </tr> <tr> <td></td> <td>AIU504-14 = 2189</td> <td>AIU504-34 = 0000</td> </tr> <tr> <td></td> <td>AIU504-15 = 1C4C</td> <td>AIU504-35 = 0004</td> </tr> <tr> <td></td> <td>AIU504-16 = 1C45</td> <td>AIU504-36 = 0UP7</td> </tr> <tr> <td></td> <td>AIU504-17 = 0010</td> <td>AIU504-37 = UF7P</td> </tr> <tr> <td></td> <td>AIU504-18 = 0000</td> <td>AIU504-38 = CP47</td> </tr> <tr> <td></td> <td>AIU504-19 = 1C4C</td> <td>AIU504-39 = CP47</td> </tr> <tr> <td></td> <td>AIU504-20 = 0000</td> <td>AIU504-40 = 1C4C</td> </tr> </table>			Power:	5 V = 1C4C		Microprocessor:	AIU504-1 = F77H	AIU504-21 = 5PC7		AIU504-2 = C98P	AIU504-22 = 5PC7		AIU504-3 = 1573	AIU504-23 = 5PC7		AIU504-4 = P42A	AIU504-24 = 6CAP		AIU504-5 = UHF8	AIU504-25 = A319		AIU504-6 = F5UC	AIU504-26 = A319		AIU504-7 = UH8C	AIU504-27 = A319		AIU504-8 = 23UC	AIU504-28 = 5PC7		AIU504-9 = 0000	AIU504-29 = 1C4C		AIU504-10 = 1C4C	AIU504-30 = 0000		AIU504-11 = 1C4C	AIU504-31 = 1C4C		AIU504-12 = C76F	AIU504-32 = 0000		AIU504-13 = U042	AIU504-33 = 0000		AIU504-14 = 2189	AIU504-34 = 0000		AIU504-15 = 1C4C	AIU504-35 = 0004		AIU504-16 = 1C45	AIU504-36 = 0UP7		AIU504-17 = 0010	AIU504-37 = UF7P		AIU504-18 = 0000	AIU504-38 = CP47		AIU504-19 = 1C4C	AIU504-39 = CP47		AIU504-20 = 0000	AIU504-40 = 1C4C
Power:	5 V = 1C4C																																																																
Microprocessor:	AIU504-1 = F77H	AIU504-21 = 5PC7																																																															
	AIU504-2 = C98P	AIU504-22 = 5PC7																																																															
	AIU504-3 = 1573	AIU504-23 = 5PC7																																																															
	AIU504-4 = P42A	AIU504-24 = 6CAP																																																															
	AIU504-5 = UHF8	AIU504-25 = A319																																																															
	AIU504-6 = F5UC	AIU504-26 = A319																																																															
	AIU504-7 = UH8C	AIU504-27 = A319																																																															
	AIU504-8 = 23UC	AIU504-28 = 5PC7																																																															
	AIU504-9 = 0000	AIU504-29 = 1C4C																																																															
	AIU504-10 = 1C4C	AIU504-30 = 0000																																																															
	AIU504-11 = 1C4C	AIU504-31 = 1C4C																																																															
	AIU504-12 = C76F	AIU504-32 = 0000																																																															
	AIU504-13 = U042	AIU504-33 = 0000																																																															
	AIU504-14 = 2189	AIU504-34 = 0000																																																															
	AIU504-15 = 1C4C	AIU504-35 = 0004																																																															
	AIU504-16 = 1C45	AIU504-36 = 0UP7																																																															
	AIU504-17 = 0010	AIU504-37 = UF7P																																																															
	AIU504-18 = 0000	AIU504-38 = CP47																																																															
	AIU504-19 = 1C4C	AIU504-39 = CP47																																																															
	AIU504-20 = 0000	AIU504-40 = 1C4C																																																															
<p>5. After completing the tests, be sure to return the J3 jumper to its original position.</p>																																																																	

Troubleshooting Procedures

Flow Charts

Troubleshooting flow charts for various circuits are given in Figures 3-5 through 3-10 and 3-12 through 3-16. The appropriate flow chart is used when a particular trouble symptom has been encountered during the self test (see Table 3-2) or when performing the overall troubleshooting procedures (see Figure 3-2). Many flow charts make reference to the test points listed in Chapter 6. The circuit locations of the test points are shown on the schematics. Test point locations are shown on the component location diagrams in Chapter 6.

Figure 3-5 isolates the fault to components on the GPIB or Isolator board or the front panel board when the display is inoperative. Figures 3-6 and 3-7 isolate the problem for OV circuit trouble symptoms. Figures 3-8 and 3-9 provide troubleshooting for output held low and output held high trouble symptoms, respectively. Figure 3-10 troubleshoots the DAC circuits. Waveforms which will aid you in troubleshooting the CV and CC DAC circuits are provided in Figure 3-11. Figure 3-12 isolates faults to either the DAC or the amplifier component in CV and CC DAC/amplifier circuits. Figures 3-13 and 3-14 provide troubleshooting procedures for the GPIB board (664xA & 665xA), the isolator board (654xA & 655xA), and the main board, respectively, when serial data line or secondary interface error messages appear on the display. Figure 3-15 is for the down programming circuit and Figure 3-16 is the Isolator Board circuits troubleshooting chart.

Bias and Reference Supplies

Many of the troubleshooting flow charts start by checking the bias and/or reference voltages to make sure that they are not causing the problem. Table 6-3 in Chapter 6 lists the bias and the reference voltage test points for the A2 GPIB board, A2 Isolator Board, and the A1 Board.

CV/CC Status Annunciators Troubleshooting

When troubleshooting the CV/CC status annunciators or the status readback circuits, first measure the voltage drop across the gating diodes; D651 (CC) and D615 (CV). A conducting diode indicates an active (ON) control circuit. This forward drop is applied to the input of the associated status comparator (U608) and drives the output low. The low signal indicates an active status which is sent to the secondary microprocessor U504 through U502. The front panel CV annunciator indicates when the CV mode is active (CV* is low). The front panel CC annunciator indicates when the CC mode is active (CC* is low). The UNREGULATED (Unr) annunciator comes on when neither the CV nor CC is active.

Post Repair Calibration

Calibration is required annually and whenever certain components are replaced. If components in any of the circuits listed below are replaced, the supply must be re-calibrated as described in Appendix A of the Operating Manual.

A1 Main Board: CV/CC DACs/operational amplifiers, CV/CC control circuit amplifiers, readback DAC/operational amplifier, readback comparators, or DAC reference circuits.

A3 Front Panel Board: If the front panel board A3 or the EPROM chip A3U6 is replaced, the supply must be initialized first (see "EEPROM INITIALIZATION" later in this chapter) and then be recalibrated as described in Appendix A in the Operating Manual.

Inhibit Calibration Jumper

If "CAL DENIED" appears on the display when the front panel calibration is attempted, or if error code 1 occurs when GPIB calibration (models 664xA & 665xA) is attempted, the INHIBIT CAL jumper (see Figure 3-3) has been installed.

This prevents power supply calibration from being changed. You must remove this jumper from the INHIBIT CAL position (between pins J3-3 and J3-4) and return it to the NORM position (between pins J3-7 and J3-8) in order to calibrate the supply.

Calibration Password

In order to enter the calibration mode, you must use the correct password as described in Appendix A of the Operating Manual. As shipped from the factory, the supply's model number (e.g., "6652") is the password. If you use an incorrect password, "PASSWD ERROR" will appear on the display for front panel calibration (or error code 2 occurs for GPIB calibration) and the calibration mode will not be enabled.

If you have changed the password and have forgotten it, you can recover the calibration function by restoring the factory preset calibration constants. To do this, proceed as follows:

- a. Turn off the supply and remove the top cover.
- b. Install jumper in test header J3 on the front panel board A3 in the FACTORY PRESET CAL position between pins J3-5 and J3-6. (See Figure 3-3.)
- c. Turn on the supply and note that "ADDR 5" and then "PWR ON INIT" appear briefly on the front panel display.
- d. When "PWR ON INIT" no longer appears on the display, the supply's factory calibration constants have been restored and the password has been changed to "0" defeating password protection. You can now turn off the supply, remove the jumper and return it to the NORM position between pins J3-7 and J3-8. (See Figure 3-3.)
- e. Turn on the supply. At this point you can set a new password (if desired) and recalibrate the supply as described in Appendix A of the Operating Manual.

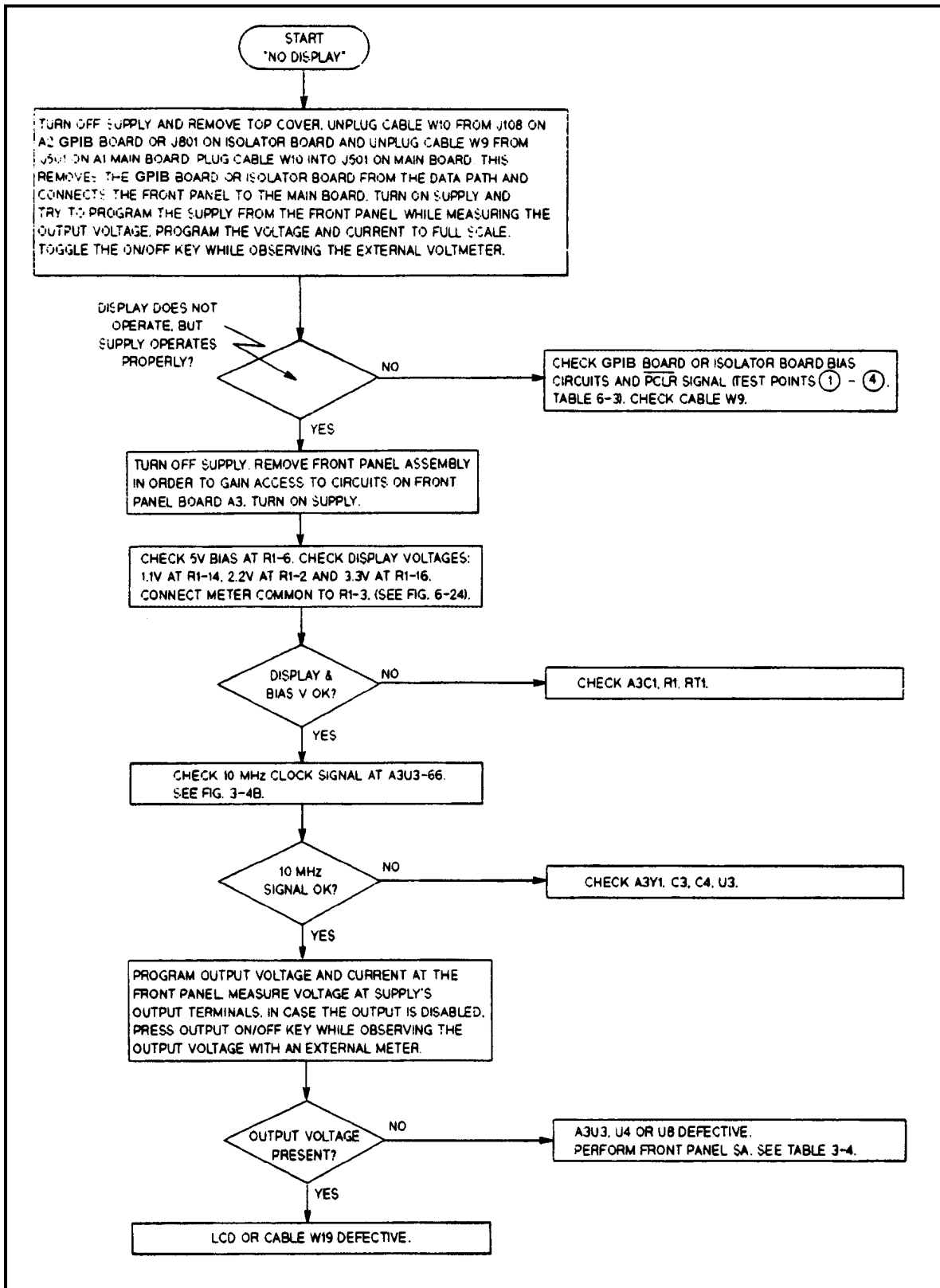

Figure 3-5. No Display Troubleshooting

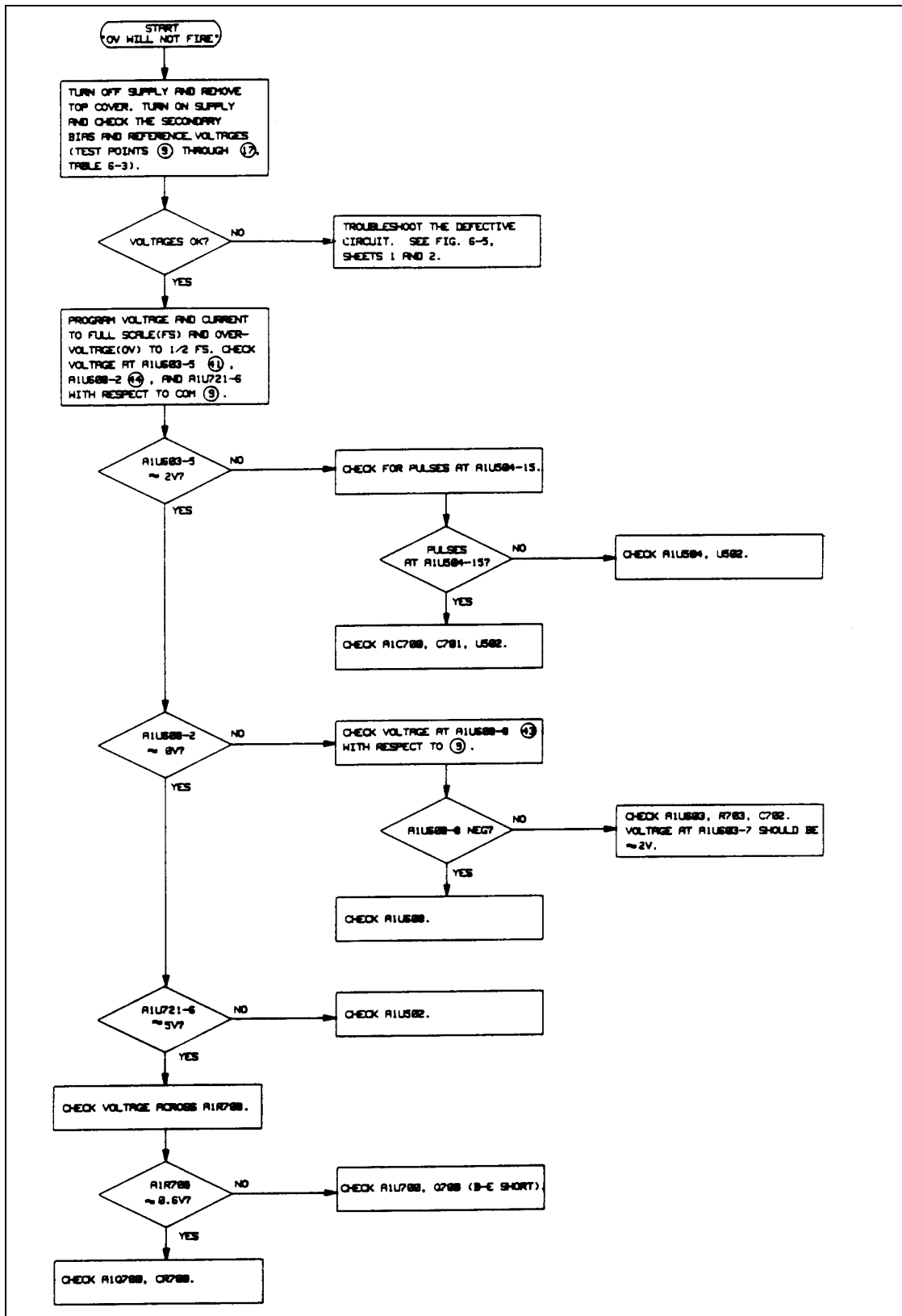

Figure 3-6. OV Will Not Fire Troubleshooting

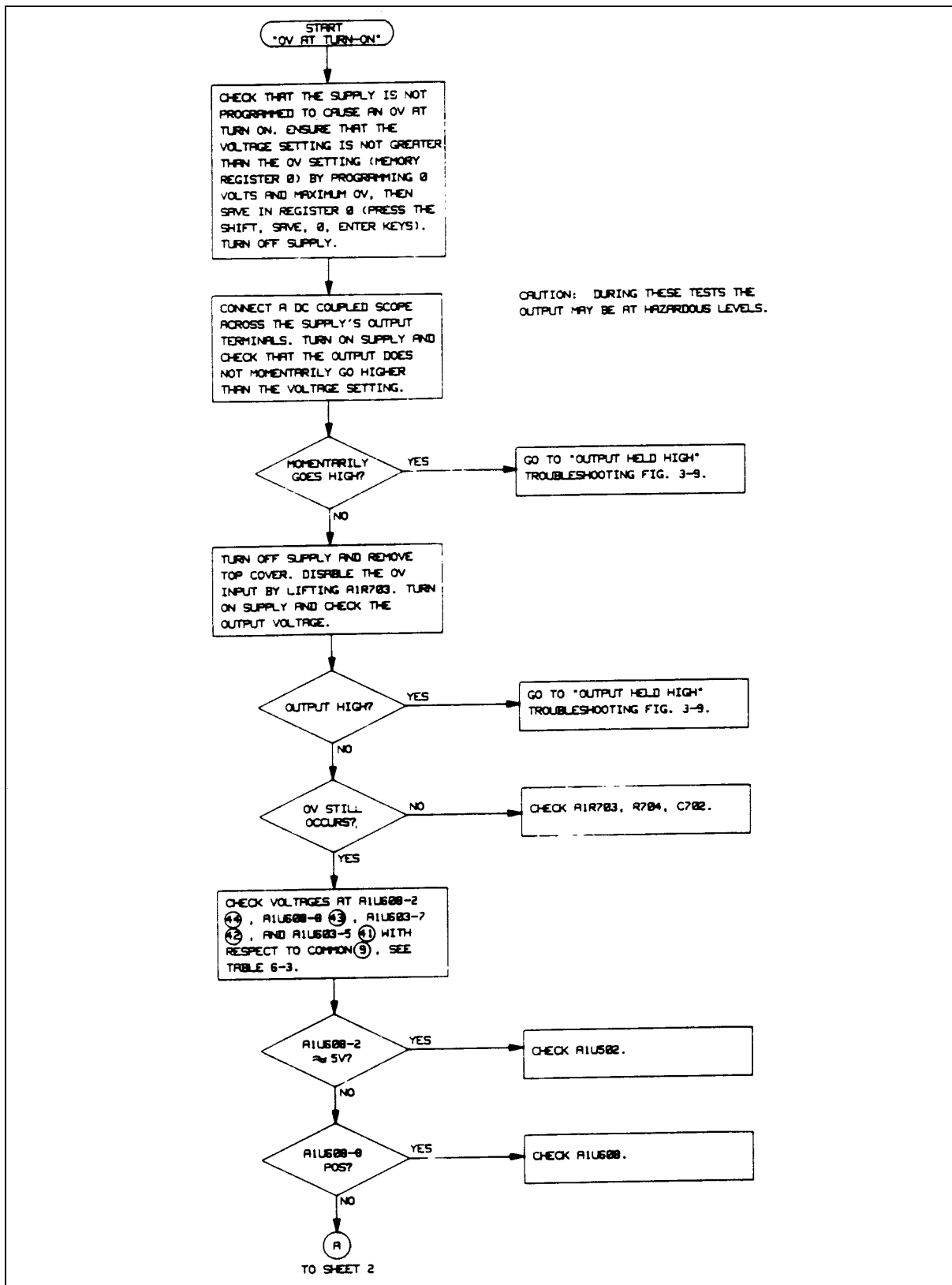

Figure 3-7. OV At Turn-On Troubleshooting (Sheet 1 of 2)

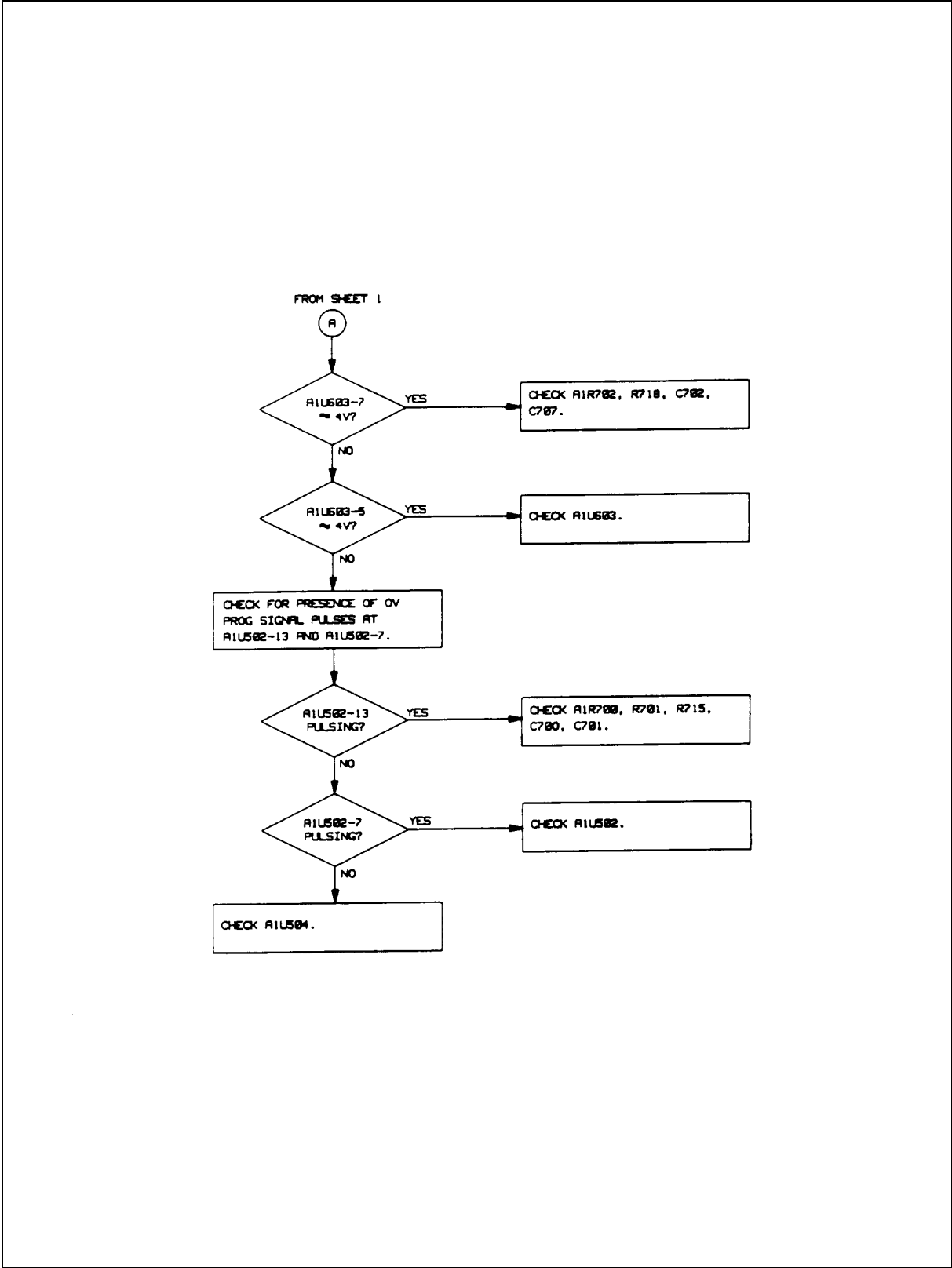

Figure 3-7. OV At Turn-On Troubleshooting (Sheet 2 of 2)

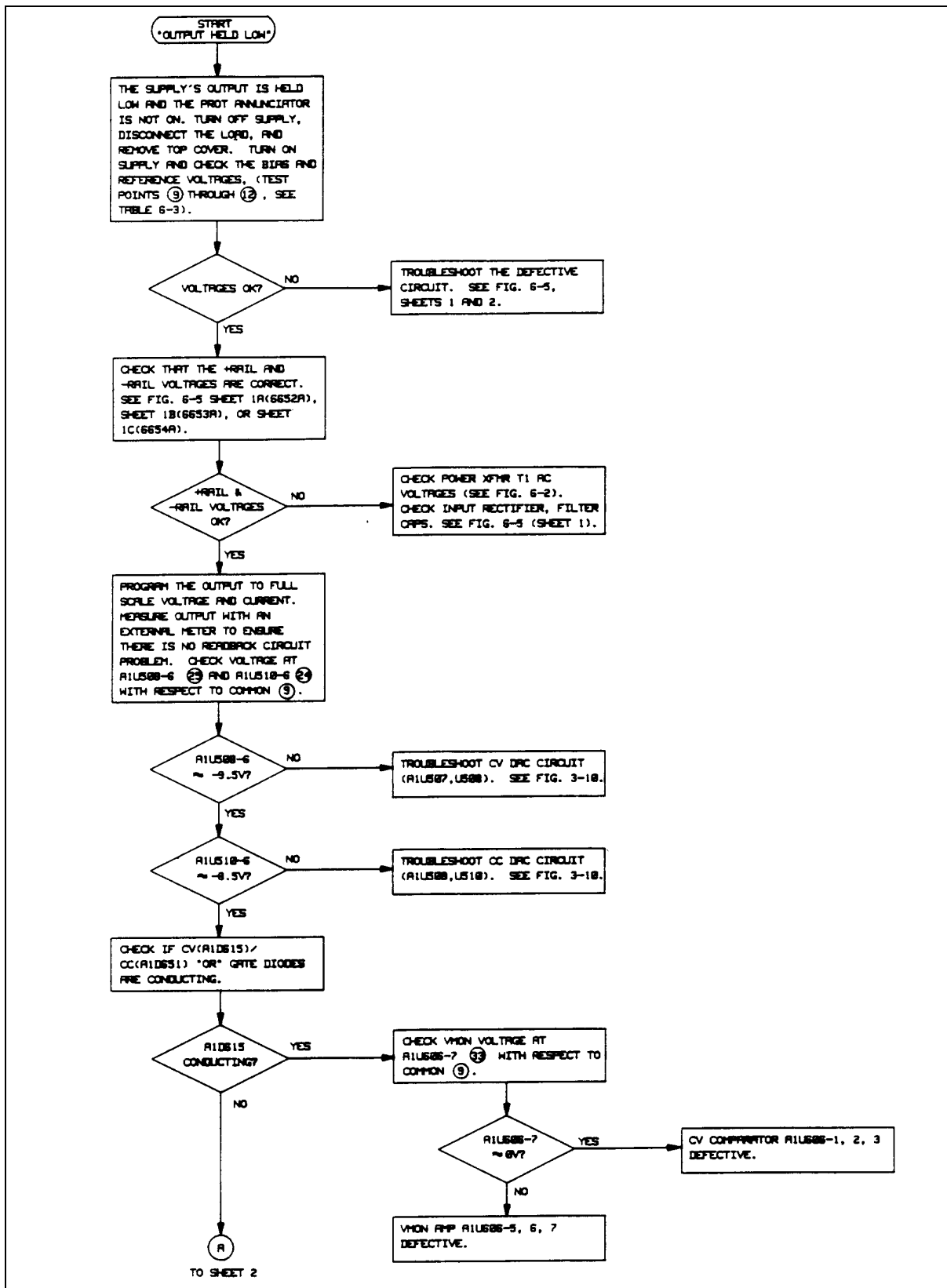

Figure 3-8. Output Held Low Troubleshooting (Sheet 1 of 2)

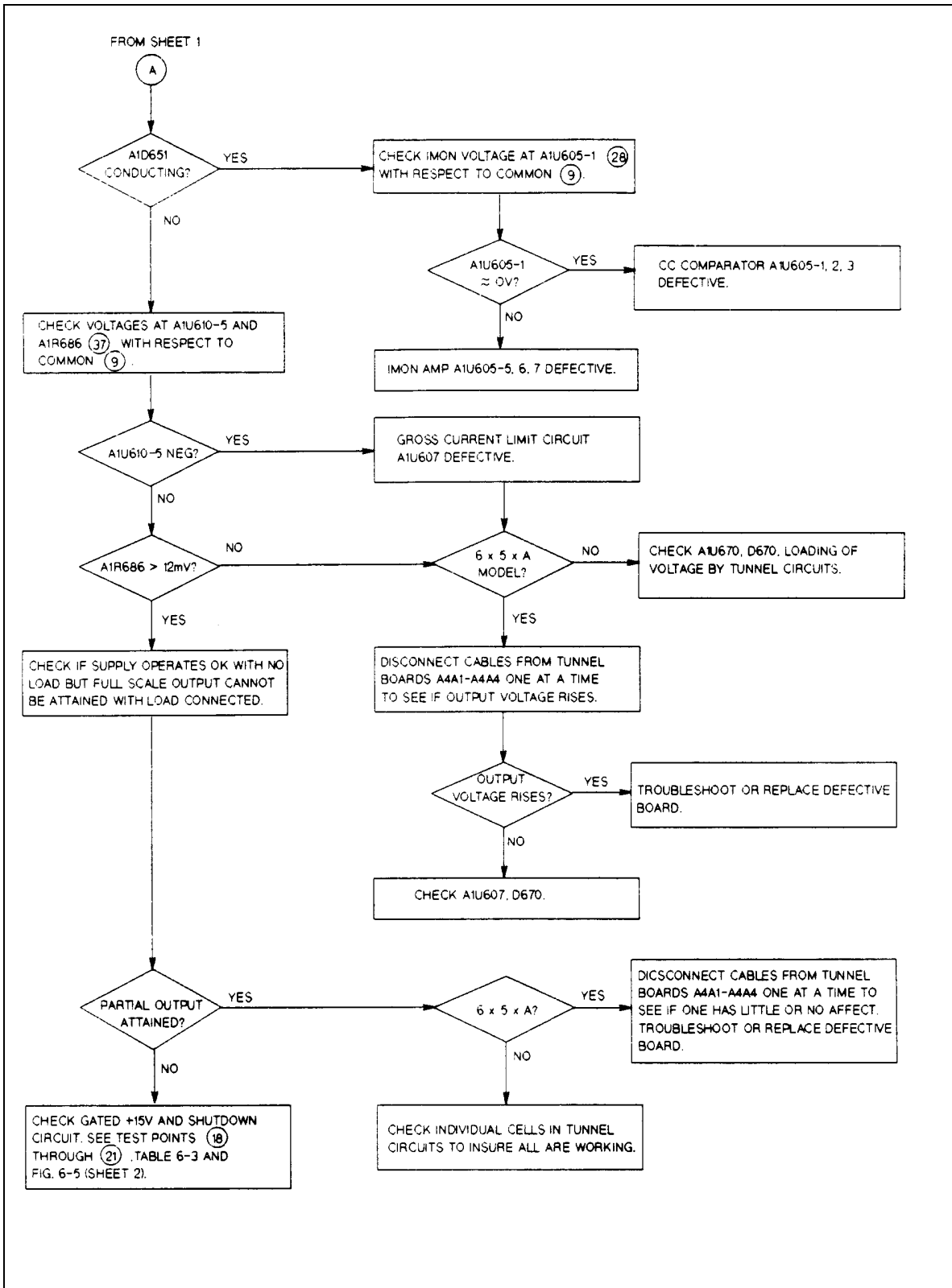

Figure 3-8. Output Held Low Troubleshooting (Sheet 2 of 2)

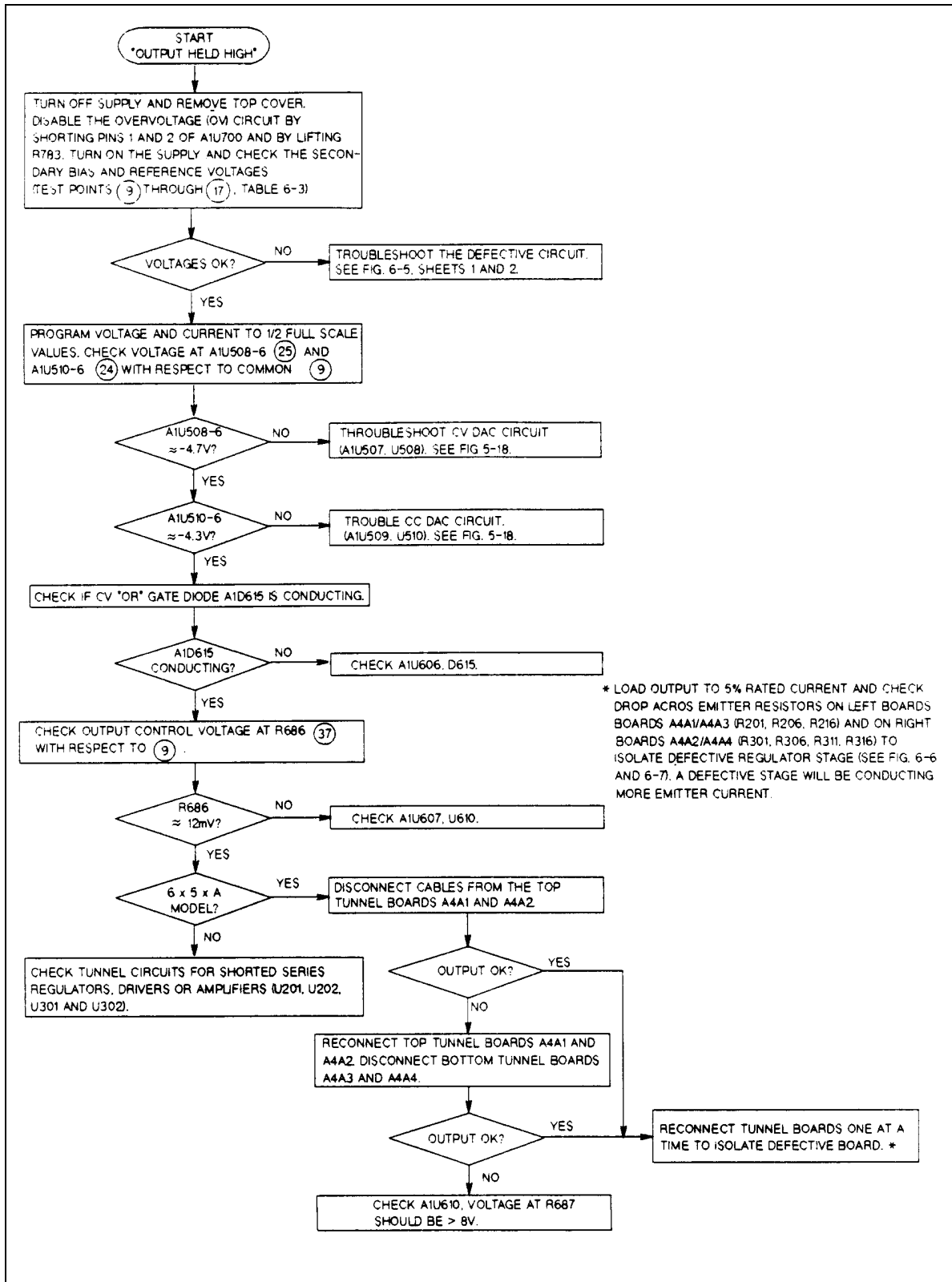

Figure 3-9. Output Held High Troubleshooting

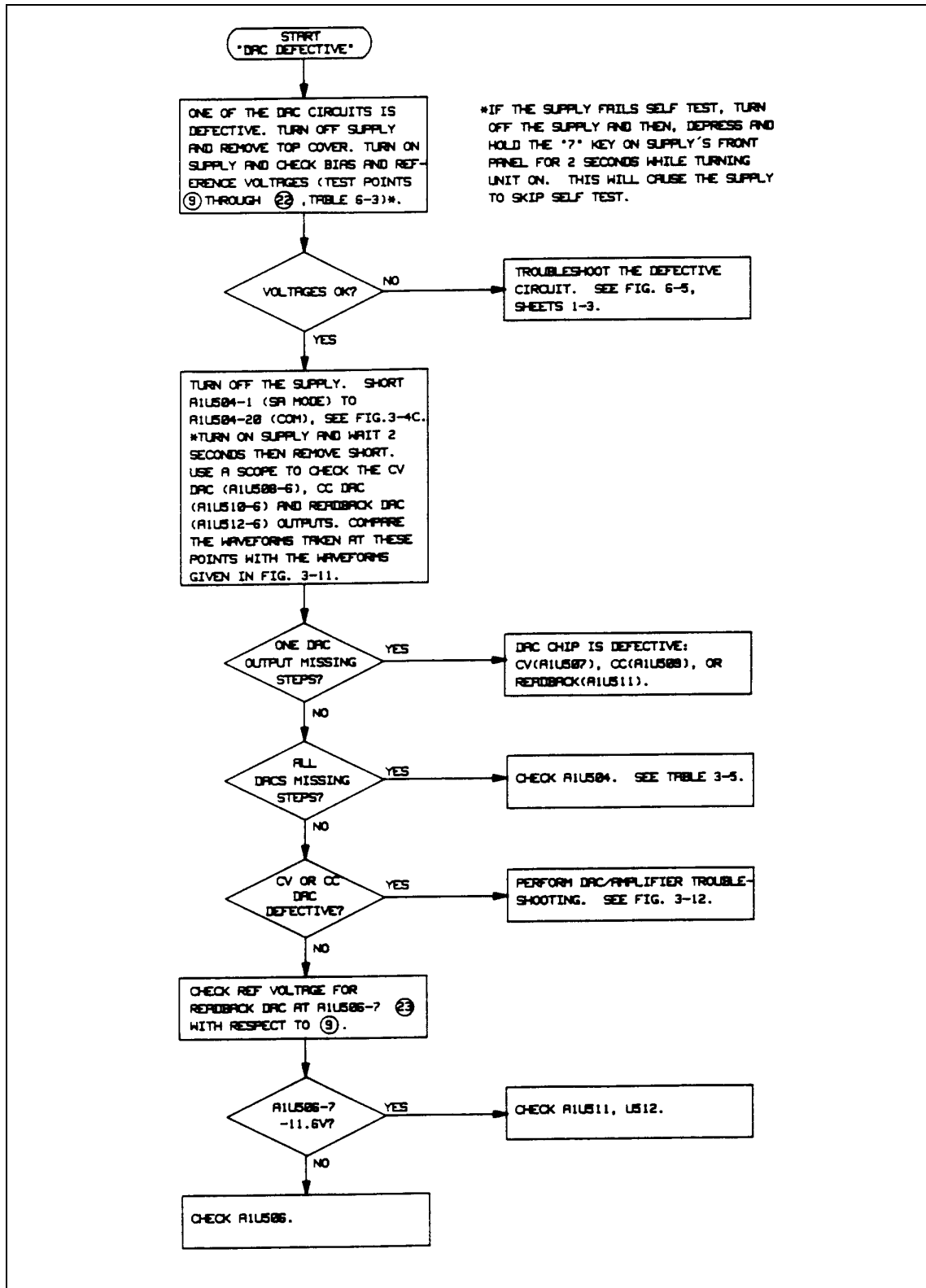

Figure 3-10. DAC Circuits Troubleshooting

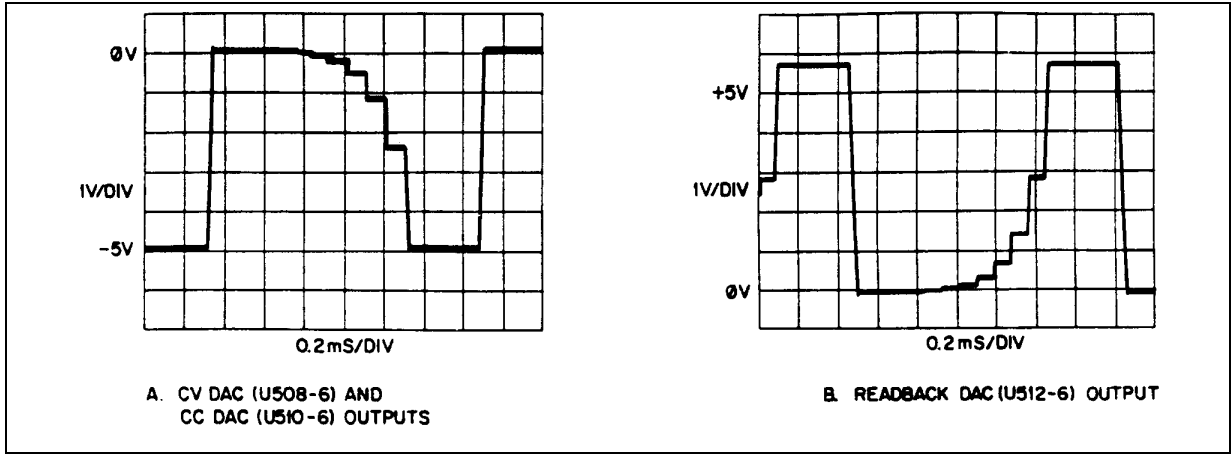

Figure 3-11. DAC Waveforms

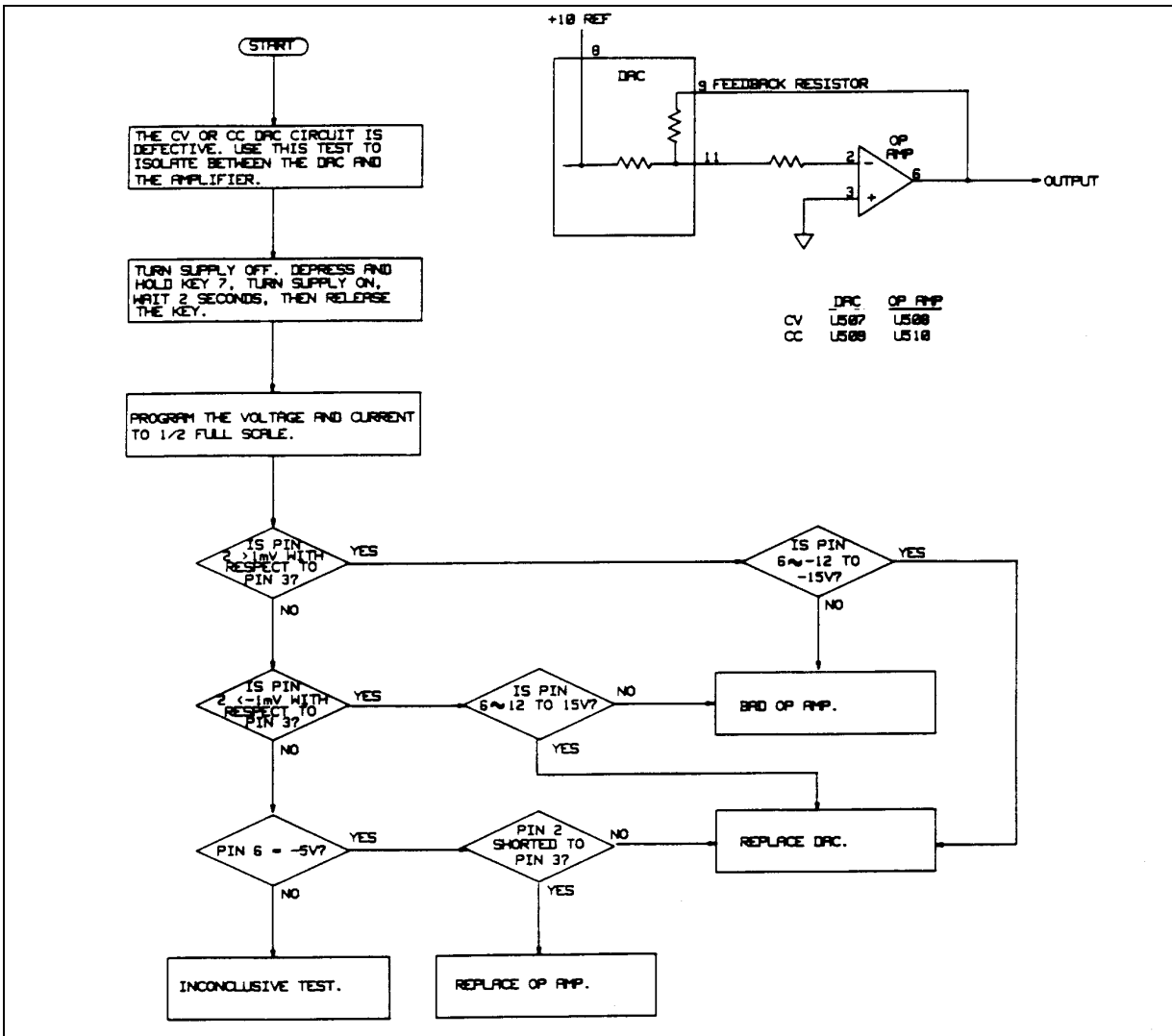

Figure 3-12. CV/CC DAC and Amplifier Troubleshooting

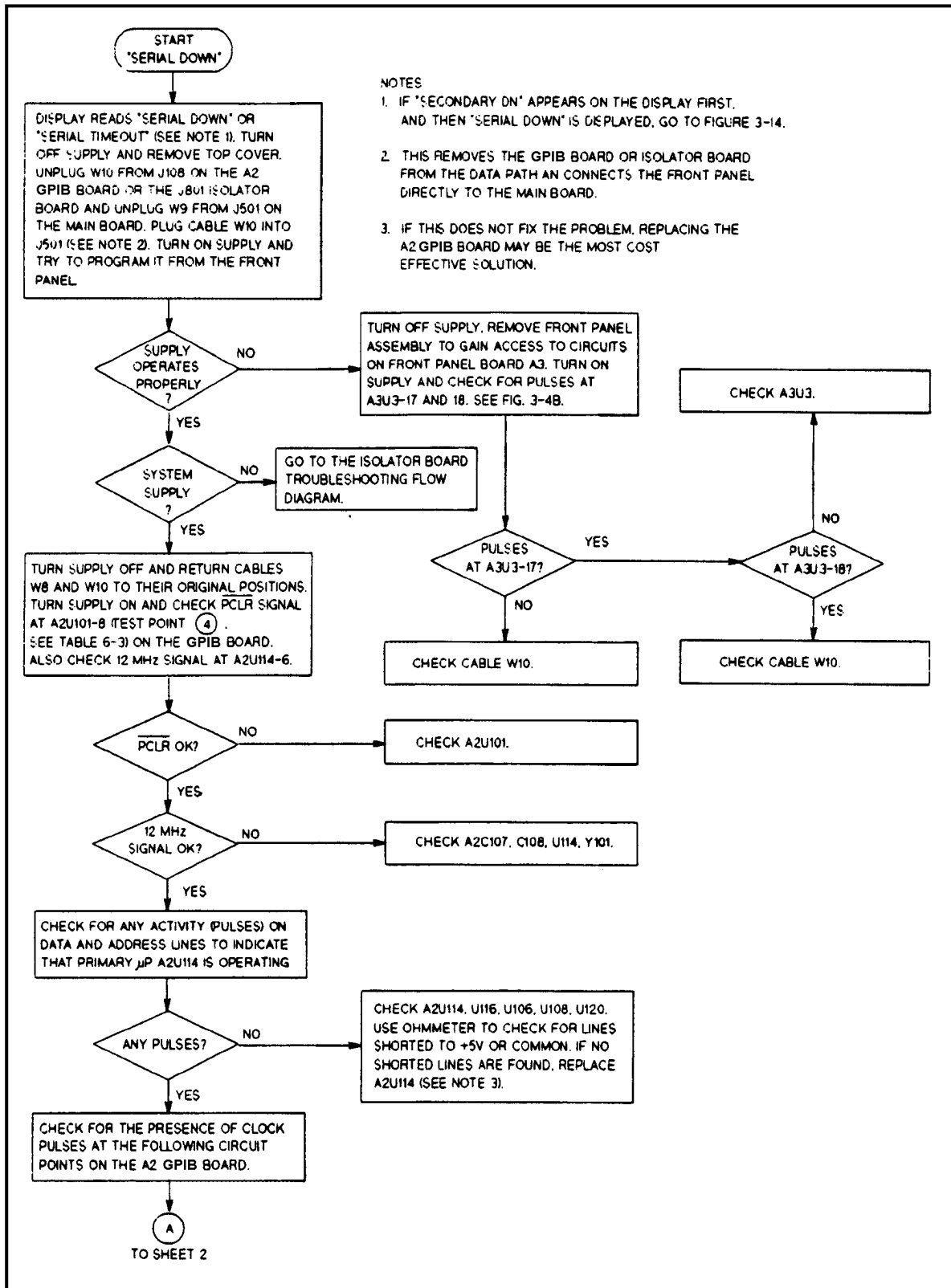

Figure 3-13. Serial Down Troubleshooting (Sheet 1 of 2)

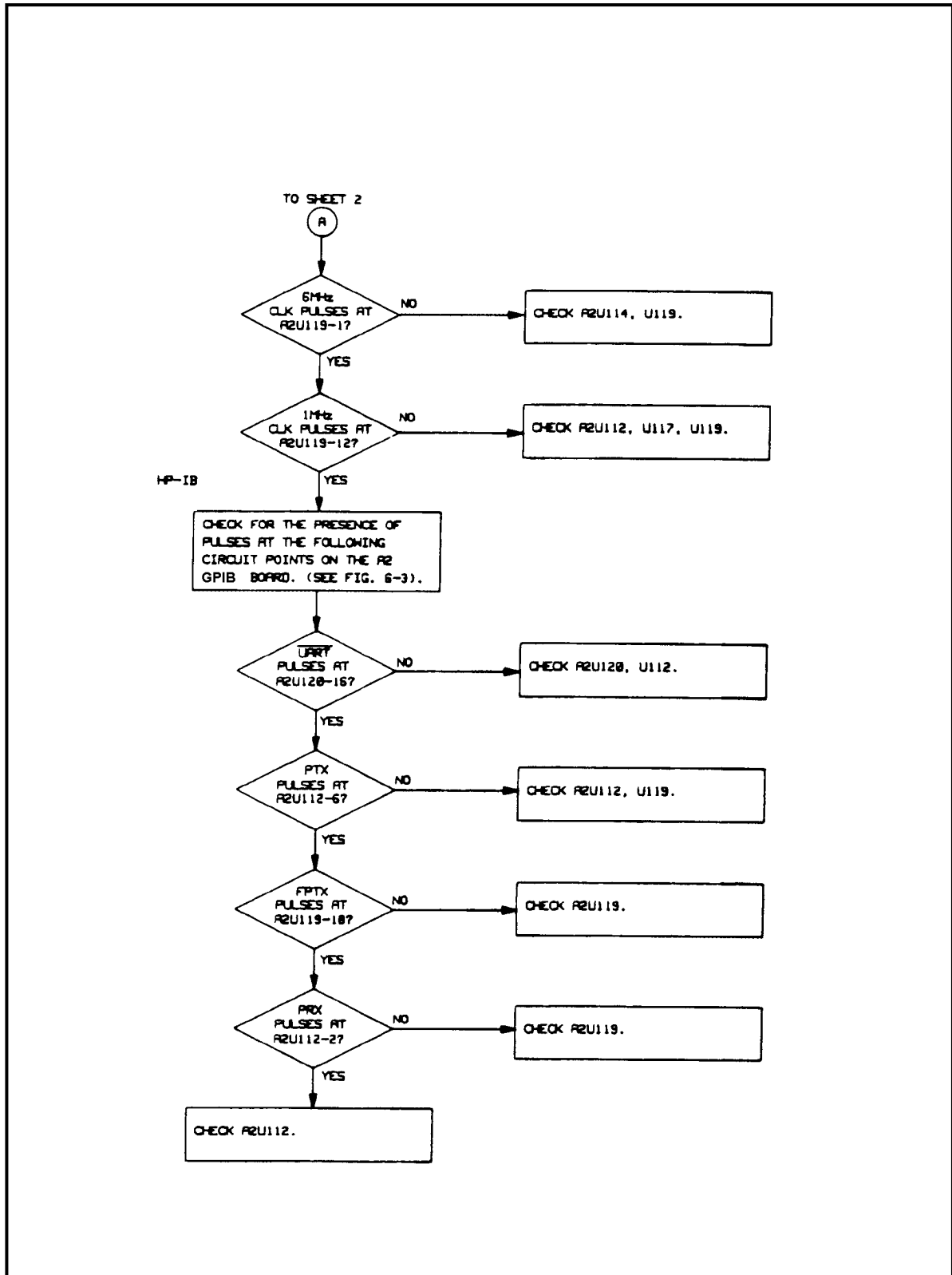

Figure 3-13. Serial Down Troubleshooting (Sheet 2 of 2)

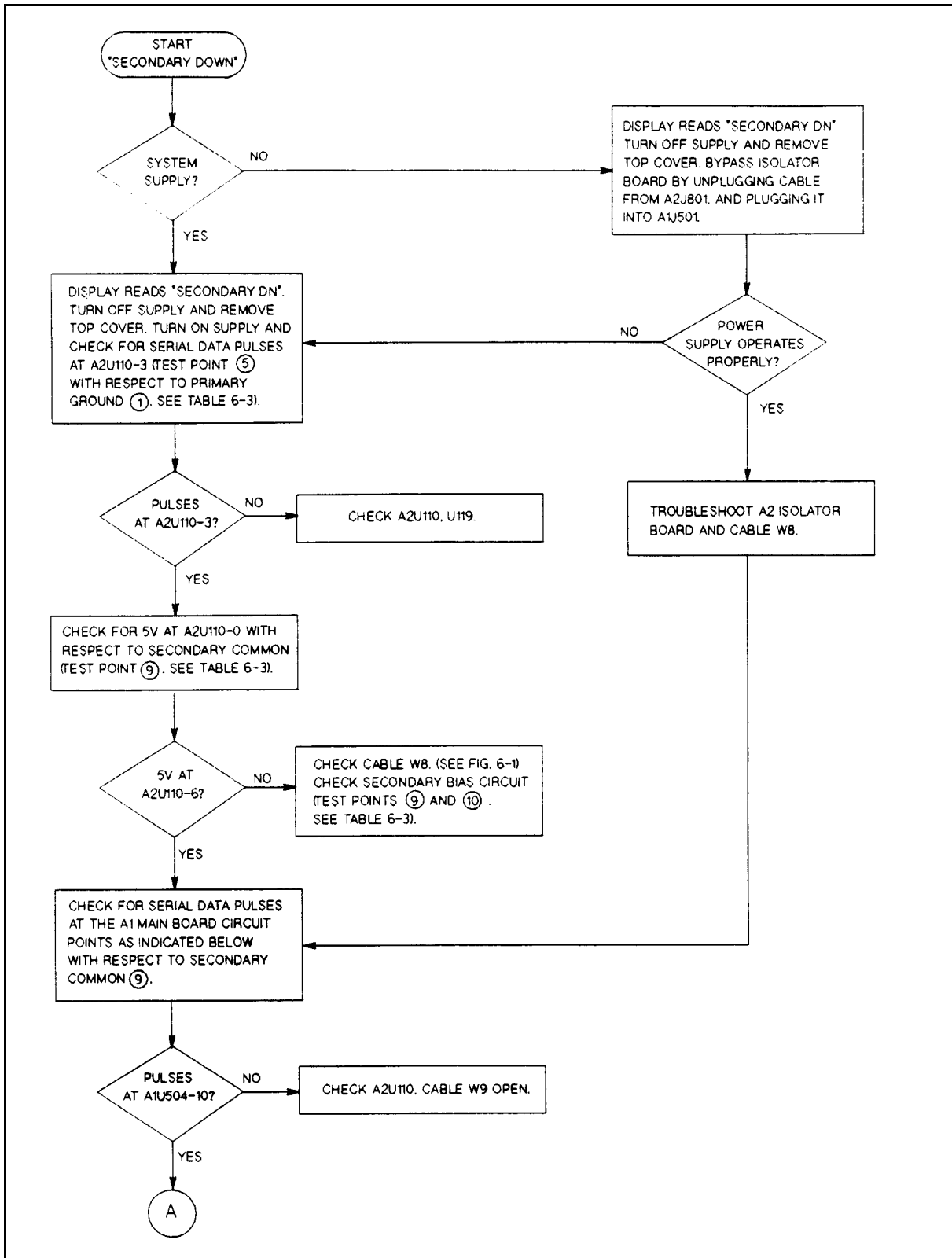

Figure 3-14. Secondary Down Troubleshooting (Sheet 1 of 2)

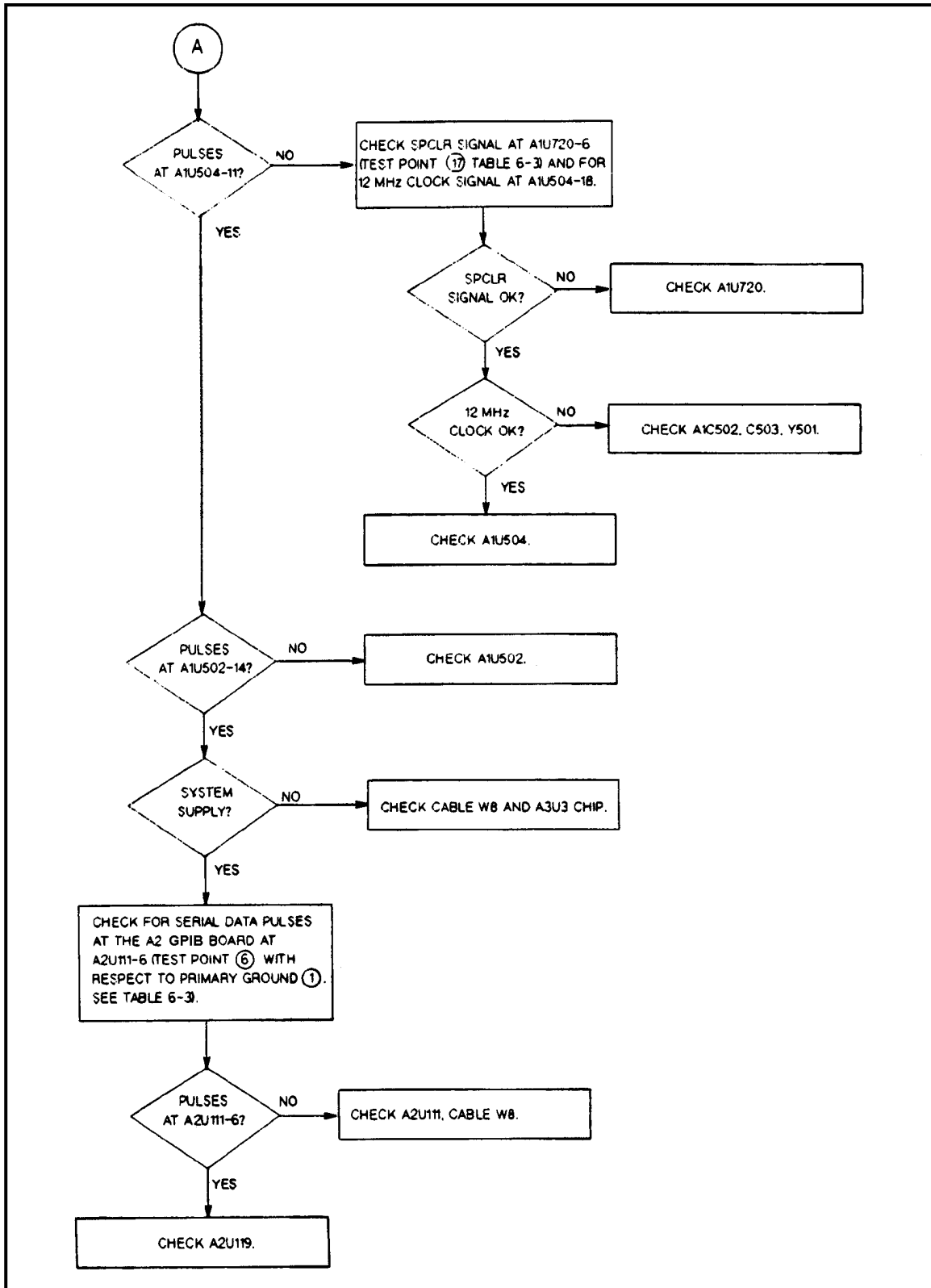

Figure 3-14. Secondary Down Troubleshooting (Sheet 2 of 2)

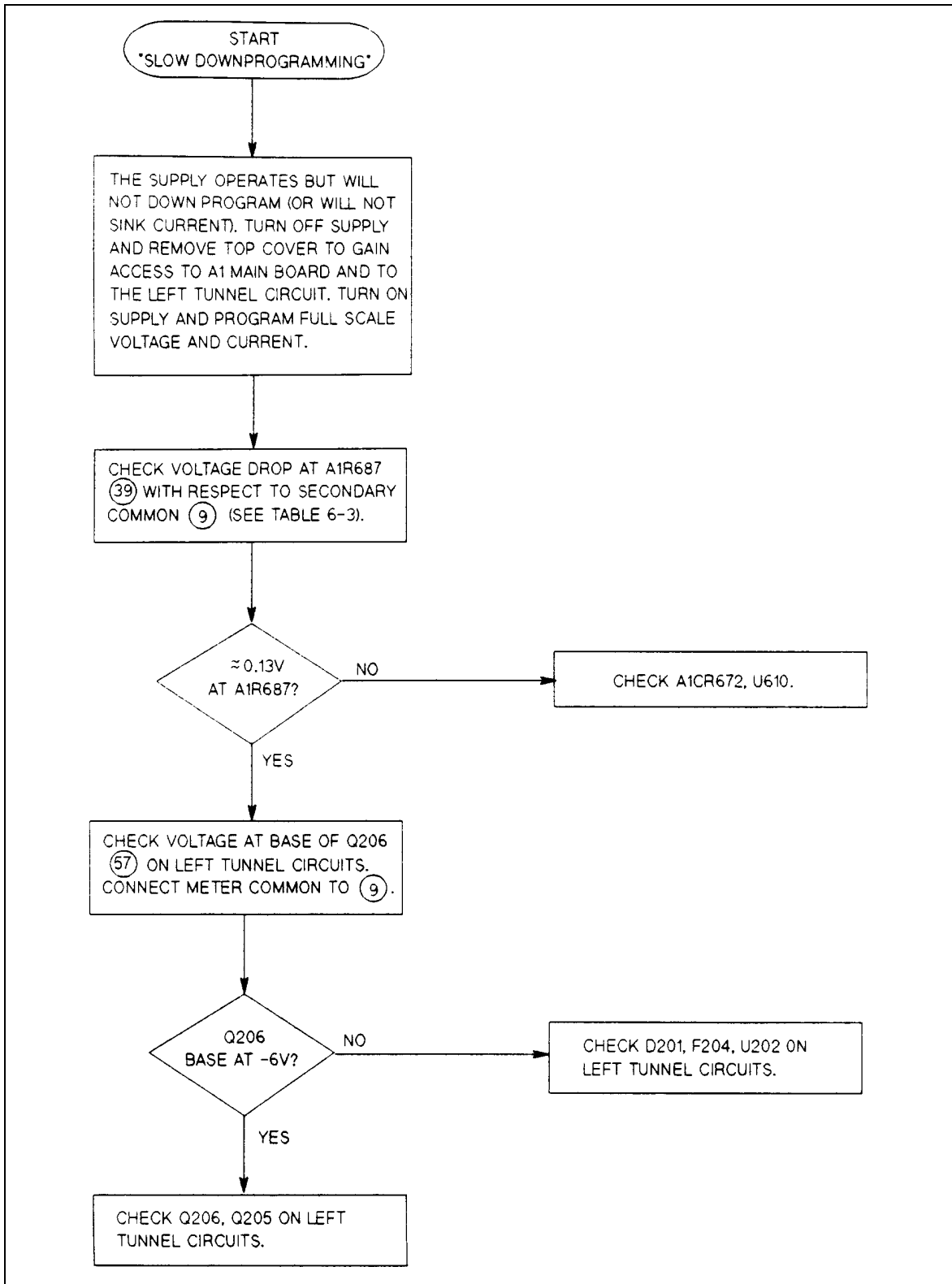

Figure 3-15. Slow Down Programming Troubleshooting

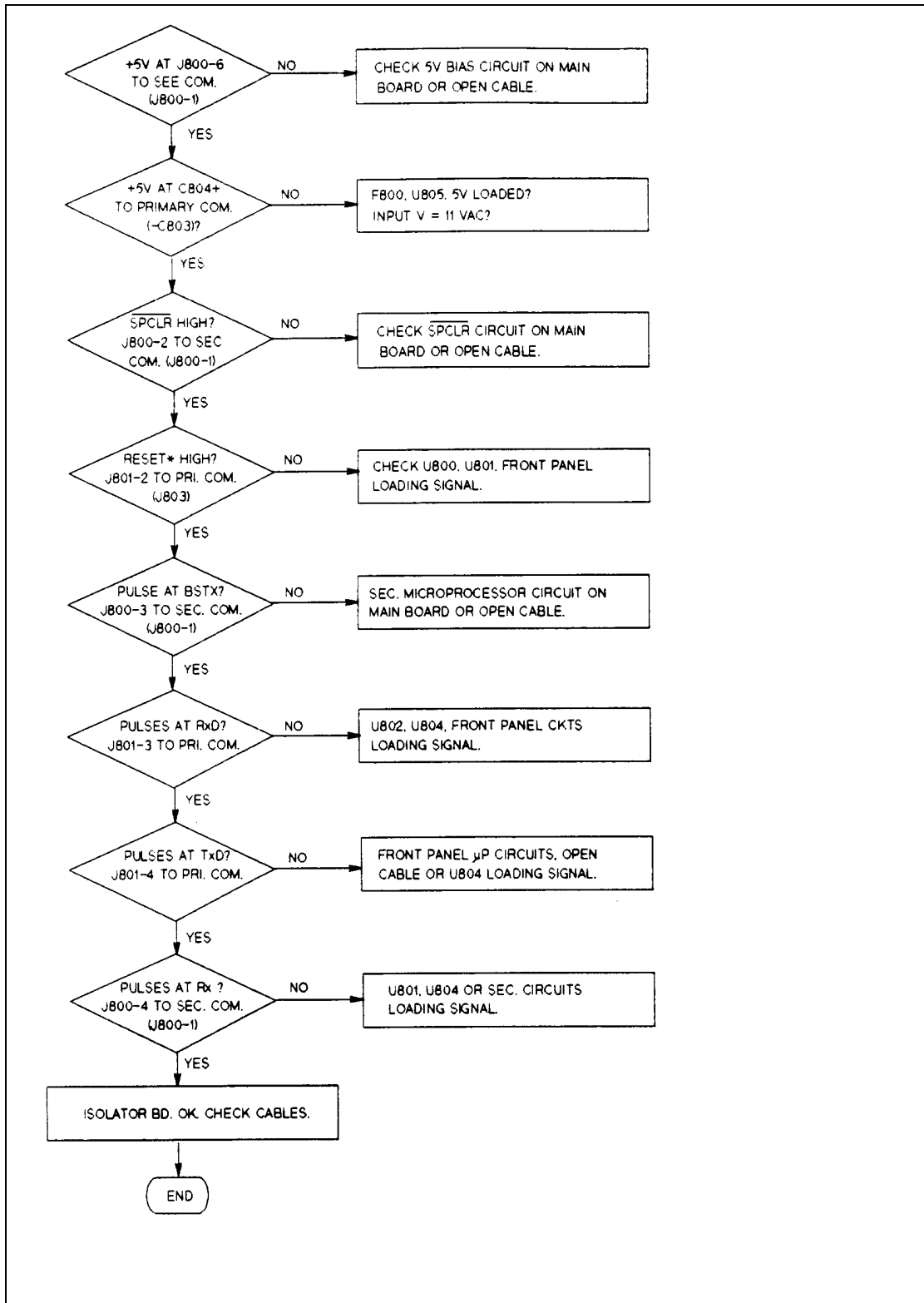

Figure 3-16. Isolator Board Circuits Troubleshooting

EEPROM Initialization

EEPROM chip A3U6 on the front panel board stores the supply's GPIB address and model number as well as other constants which are required to program and calibrate the supply. The EEPROM was initialized with the proper constants before the supply was shipped from the factory. If the front panel board, A3, or the EEPROM chip, A3U6, is replaced, the supply must be reinitialized with the proper constants by running the program listed in Figure 3-17.

The program will pause and prompt you to select either "Initialization (I)" or "Factory Preset Replacement (F)." You must select "I" in order for the program to continue and initialize the supply. After the supply has been initialized using this program, it must be calibrated as described in Appendix A of the operating Manual. After calibration has been completed, you should transfer the calibration constants to the new EEPROM's "Factory Cal" locations as described below.

Note

If the EEPROM (A3U6) or the front panel board is replaced, the EEPROM must be reinitialized. For models 654xA & 655xA, a separate GPIB board can be installed temporarily in place of the A2 Isolator Board in order to perform the reinitialization.

For 664xA & 665xA models, the program in Figure 3-17 can be run to reinitialize the supply. This program contains statements for several different Keysight models. You can shorten and thus customize this program for just your specific model by deleting the statements from this program listing that apply to models that you do not use.

Transferring Calibration Constants Into Factory Preset Locations

This will allow you to recover the new calibration constants using the FACTORY PRESET CAL jumper as described previously. Being able to recover the calibration constants could be important in the future if you have trouble calibrating the supply. Having the FACTORY PRESET CAL constants available, will allow you to operate the supply and/or re-calibrate as required. After you have initialized and calibrated the supply, transfer the calibration constants into the FACTORY PRESET CAL locations, by again running the program listed in Figure 3-17. This time when the program pauses for you to make the selection, select "Factory Preset Replacement (F)". After you select "F," the program will continue and transfer the newly obtained calibration constants into the proper locations of the new EEPROM.

```

10 ! Program to initialize EEPROM or move factory preset data in 654xA,
20 ! 664xA, 655xA and 665xA power supplies.
30 ! RE-STORE "INIT_ps"
40 ! Rev A.00.00 dated Mar 30, 1993
50 !
60 DIM Init_data(1:45),Model$(5),Idn$(21),Cal_data$(40)
70 INTEGER Addr(1:45),Length(1:45)
80 ASSIGN @Ps TO 705 ! Supply must be at address 705
90 CLEAR SCREEN
100 !
110 Eprom_data_addr: ! Data address
120 DATA 2,6,10,14,18,19,20,24,28,32
130 DATA 36,37,38,42,46,50,54,55,56,57
140 DATA 64,68,72,76,80,150,152,153,154,155
150 DATA 156,158,160,162,163,164,165,166,167,168
160 DATA 169,170,171,172,174
170 !
180 Eprom_data_len: ! Data for word length
190 DATA 4,4,4,4,1,1,4,4,4,4
200 DATA 1,1,4,4,4,4,1,1,1,1
210 DATA 4,4,4,4,4,2,1,1,1,1
220 DATA 2,2,2,1,1,1,1,1,1,1
230 DATA 1,1,1,2,1
240 !
250 Eprom_data_6x41: ! EEPROM data for 6541A and 6641A
260 DATA 468.3,16.6,8.19,0,83,0,177,140,20,475,0
270 DATA 99,1,78.25,78.25,8.8,0,83,255,20,10
280 DATA 6541,456.09,168.18,182,168.18,1768,5,255,0,0
290 DATA 16,6541,0,20,180,20,180,156,37,26
300 DATA 120,15,20,0,4
310 !
320 Eprom_data_6x42: ! EEPROM data for 6542A and 6642A
330 DATA 195.534,4.434,20.475,0,83,0,354,140,10,238,0
340 DATA 99,1,42.512,17.75,22,0,83,255,20,10
350 DATA 6542,167,156,365,156,1768,5,255,0,0
360 DATA 16,6542,0,20,180,20,180,156,37,26
370 DATA 120,15,20,0,4
380 !
390 Eprom_data_6x43: ! EEPROM data for 6543A and 6643A
400 DATA 111,16.6,35.81,0,83,0,587,140,6,143,0
410 DATA 99,1,18.68,78.75,38.5,0,83,255,20,10
420 DATA 6543,104.3,171.7,607,164.2,1768,5,255,0,0
430 DATA 16,6543,0,20,180,20,180,156,37,26
440 DATA 120,15,20,0,4
450 !
460 Eprom_data_6x44: ! EEPROM data for 6544A and 6644A
470 DATA 64.8,16.6,61.425,0,83,0,1010,136.86,3.583,0
480 DATA 99,1,10.43,78.2,66,0,83,255,20,10
490 DATA 6544,60.81,168.18,1044,168.18,1768,5,255,0,0
500 DATA 16,6544,0,20,180,20,180,156,37,26
510 DATA 120,15,20,0,4

```

Figure 3-17. Initialization and Factory Preset Replacement Program Listing (Sheet 1 of 6)

```

520      !
530 Eprom_data_6x45: !                               ! EEPROM data for 6545A and 6645A
540      DATA 32.42,16.6,122.85,0,82,0,2358,140,1.537,0
550      DATA 100,1,5.313,117.38,132,0,82,255,20,10
560      DATA 6545,30.41,168.18,2436,168.18,1768,5,255,0,0
570      DATA 16,6545,0,20,180,20,180,156,37,26
580      DATA 186,15,20,0,4
590      !
600 Eprom_data_6x51: !                               ! EEPROM data for 6551A and 6651A
610      DATA 486.3,16.6,8.19,0,83,0,70.16,136.86,51.188,0
620      DATA 99,1,78.25,78.25,8.8,0,83,255,20,10
630      DATA 6551,456.09,168.18,72.47,168.18,1768,5,255,0,0
640      DATA 16,6551,0,20,180,20,180,156,37,26
650      DATA 186,15,20,0,4
660      !
670 Eprom_data_6x52: !                               ! EEPROM data for 6552A and 6652A
680      DATA 195.534,4.434,20.475,0,83,0,141.87,97.29,25.594,0
690      DATA 99,1,42.512,17.75,22,0,83,255,20,10
700      DATA 6552,167,156,130,156,1768,5,255,0,0
710      DATA 16,6552,0,20,180,20,180,156,37,26
720      DATA 186,15,20,0,4
730      !
740 Eprom_data_6x53: !                               ! EEPROM data for 6553A and 6653A
750      DATA 111,16.35,35.831,0,83,0,224,127,15.356,0
760      DATA 99,1,18.68,79.5,38.5,0,83,255,20,10
770      DATA 6553,104.3,171.7,231.8,164.2,1768,5,255,0,0
780      DATA 16,6553,0,20,180,20,180,156,37,26
790      DATA 186,15,20,0,4
800      !
810 Eprom_data_6x54: !                               ! EEPROM data for 6554A and 6654A
820      DATA 64,16.35,61.425,0,83,0,393,127,9.214,0
830      DATA 99,1,10.43,78.2,66,0,83,255,20,10
840      DATA 6554,60.81,168,405.41,168.18,1768,5,255,0,0
850      DATA 16,6554,0,20,180,20,180,156,37,26
860      DATA 186,15,20,0,4
870      !
880 Eprom_data_6x55: !                               ! EEPROM data for 6555A and 6655A
890      DATA 32.42,16.6,122.85,0,82,0,882.98,136.86,4.095,0
900      DATA 100,1,5.313,117.38,132,0,82,255,20,10
910      DATA 6555,30.41,168.18,912.18,168.18,1768,5,255,0,0
920      DATA 16,6555,0,20,180,20,180,156,37,26
930      DATA 186,15,20,0,4
940      !
950      INPUT "Input Power Supply model number.  Example: ""6641A""",Model$
960      Model$=TRIM$(UPC$(Model$))
970      CLEAR SCREEN
980      !
990      RESTORE Eprom_data_addr
1000     !
1010     FOR I=1 TO 45
1020         READ Addr(I)

```

Figure 3-17. Initialization and Factory Preset Replacement Program Listing (Sheet 2 of 6)

```

1030 NEXT I
1040 !
1050 RESTORE Eprom_data_len
1060 !
1070 FOR I=1 TO 45
1080     READ Length(I)
1090 NEXT I
1100 !
1110 SELECT Model$
      uppercase
1120 !
1130 CASE "6541A"
1140     RESTORE Eprom_data_6x41
1150 CASE "6542A"
1160     RESTORE Eprom_data_6x42
1170 CASE "6543A"
1180     RESTORE Eprom_data_6x43
1190 CASE "6544A"
1200     RESTORE Eprom_data_6x44
1210 CASE "6545A"
1220     RESTORE Eprom_data_6x45
1230 !
1240 CASE "6641A"
1250     RESTORE Eprom_data_6x41
1260 CASE "6642A"
1270     RESTORE Eprom_data_6x42
1280 CASE "6643A"
1290     RESTORE Eprom_data_6x43
1300 CASE "6644A"
1310     RESTORE Eprom_data_6x44
1320 CASE "6645A"
1330     RESTORE Eprom_data_6x45
1340 !
1350 CASE "6551A"
1360     RESTORE Eprom_data_6x51
1370 CASE "6552A"
1380     RESTORE Eprom_data_6x52
1390 CASE "6545A"
1400     RESTORE Eprom_data_6x53
1410 CASE "6554A"
1420     RESTORE Eprom_data_6x54
1430 CASE "6555A"
1440     RESTORE Eprom_data_6x55
1450 !
1460 CASE "6651A"
1470     RESTORE Eprom_data_6x51
1480 CASE "6652A"
1490     RESTORE Eprom_data_6x52
1500 CASE "6653A"
1510     RESTORE Eprom_data_6x53
1520 CASE "6654A"

```

Figure 3-17. Initialization and Factory Preset Replacement Program Listing (Sheet 3 of 6)

```

1530 RESTORE Eprom_data_6x54
1540 CASE "6655A"
1550 RESTORE Eprom_data_6x55
1560 !
1570 CASE ELSE
1580 PRINT "Model number not found. Program is for Keysight models"
1590 PRINT "6541A, 6542A, 6543A, 6544A and 6545A"
1600 PRINT "6641A, 6642A, 6643A, 6644A and 6645A"
1610 PRINT "6551A, 6552A, 6553A, 6554A and 6555A"
1620 PRINT "6651A, 6652A, 6663A, 6654A and 6655A"
1630 STOP
1640 END SELECT
1650 !
1660 FOR I=1 TO 45 ! Read model dependent data
1670 READ Init_data(I)
1680 IF I=21 OR I=32 THEN Init_data(I)=VAL(Model$)
1690 NEXT I
1700 !
1710 OUTPUT @Ps;"*CLS" ! Clears power supply registers
1720 !
1730 OUTPUT @Ps;"CAL:STATE ON," ! Turn on cal mode, "0" passcode
1740 !
1750 GOSUB Ps_error ! Error if passcode is not "0"!
1760 IF Err THEN
1770 OUTPUT @Ps;"*IDN?" ! Get data from model # location
1780 ENTER @Ps;Idn$
1790 Model=VAL(Idn$[POS(Idn$,"")+1])
1800 ELSE
1810 GOTO Start
1820 END IF
1830 !
1840 OUTPUT @Ps;"CAL:STATE ON,";Model ! Turn on cal mode, passcode =
1850 ! data at model number location
1860 !
1870 GOSUB Ps_error ! Error if passcode is not same as
1880 ! data at model & location
1890 IF Err THEN
1900 OUTPUT @Ps;"CAL:STATE ON,";Model$[1,4] ! Turn on cal mode, passcode =
1910 ! model #
1920 GOSUB Ps_error
1930 IF Err THEN
1940 PRINT "Change pass code to the power supply model # or zero then restart the program."
1950 STOP
1960 ELSE
1970 GOTO Start
1980 END IF
1990 END IF
2000 !
2010 Start: !
2020 !

```

Figure 3-17. Initialization and Factory Preset Replacement Program Listing (Sheet 4 of 6)

```

2030      !
2040  INPUT "Select Initialization (I) or Factory preset replacement (F).",Sel$
2050  CLEAR SCREEN
2060  SELECT (UPC$(Sel$))
2070  CASE "I"                                ! Select Initialization
2080      GOTO Init_eeprom
2090  CASE "F"                                ! Select install new factory data
2100      GOTO Fact_preset
2110  CASE ELSE
2120      BEEP
2130      GOTO Start
2140  END SELECT
2150      !
2160 Init_eeprom:      !
2170  PRINT "Initializing EEPROM"
2180      !
2190  FOR I=1 TO 45
2200      OUTPUT @Ps;"DIAG:EEPR ";Addr(I);";Length(I);";Init_data(I)
2210  NEXT I
2220  GOTO Cal_off
2230  !
2240  !
2250 Fact_preset:      !
2260  CLEAR SCREEN
2270  PRINT "This program should ONLY be completed if your power supply"
2280  PRINT "EEPROM has been replaced or a component that will effect"
2290  PRINT "the calibration AND the alignment of voltage, overvoltage"
2300  PRINT "and current is complete AND unit has passed the performance"
2310  PRINT "test.          Enter C to continue, any other key to abort."
2320  INPUT Cont_prog$
2330  IF (UPC$(Cont_prog$))<>"C" THEN GOTO Cal_off
2340  !
2350  CLEAR SCREEN
2360  PRINT "Transferring calibration data to factory preset locations."
2370  !
2380 Fact_cal_sour:    ! Address of factory calibration data source
2390  DATA 2,6,68,72,20,24,76,80,150
2400  !
2410 Fact_cal_dest:   ! Address of factory calibration data destination
2420  DATA 84,88,92,96,100,104,108,112,116
2430  !
2440 Fact_cal_len:    ! Length of factory calibration data
2450  DATA 4,4,4,4,4,4,4,4,2
2460  !
2470  RESTORE Fact_cal_sour
2480  FOR I=1 TO 9
2490      READ Cal_sour_addr(I)
2500  NEXT I
2510  !
2520  RESTORE Fact_cal_dest
2530  FOR I=1 TO 9

```

Figure 3-17. Initialization and Factory Preset Replacement Program Listing (Sheet 5 of 6)

```

2540     READ Cal_dest_addr(I)
2550     NEXT I
2560     !
2570     RESTORE Fact_cal_len
2580     FOR I=1 TO 9
2590         READ Cal_length(I)
2600     NEXT I
2610     !
2620     FOR I=1 TO 9                                     ! Locations of good data
2630         OUTPUT @Ps;"DIAG:EEPR?";Cal_sour_addr(I);";Cal_length(I)
Read good data
2640         ENTER @Ps;Cal_data$                          ! Enter good data
2650         OUTPUT @Ps;"DIAG:EEPR";Cal_dest_addr(I);";Cal_length(I);";Cal_data$ !
Write good data to factory preset locations
2660     NEXT I
2670     !
2680     !
2690 Cal_off
2700     CLEAR SCREEN
2710     OUTPUT @Ps;"CAL:STATE OFF"                       ! Turn off cal mode
2720     !
2730     GOSUB Ps_error                                   ! Check for errors
2740     IF Err THEN
2750         PRINT "An error occurred during the EEPROM read/write, Check for"
2780         PRINT "programming errors. Initialization data may be incorrect."
2770         STOP
2780     END IF
2790     !
2800     PRINT "Operation complete. Program stopped."
2810     STOP
2820     !
2830 Ps_error:                                          ! Error handling subroutine
2840     OUTPUT @Ps;"SYST:ERR?"                          ! Check for errors
2850     ENTER @Ps;Err
2860     RETURN
2870     !
2880     END

```

Figure 3-17. Initialization and Factory Preset Replacement Program Listing (Sheet 6 of 6)

Disassembly Procedures

The following paragraphs provide instructions on how to disassemble various components of the power supply. Once disassembled, the components can be reassembled by performing the disassembly instructions in reverse order.

WARNING

SHOCK HAZARD. To avoid the possibility of personal injury, turn on AC power and disconnect the line cord before removing the top cover. Disconnect the GPIB cable (for 664xA & 665xA models), and any loads, and remote sense leads before attempting disassembly.

CAUTION

Most of the attaching hardware is metric. Use of other types of fasteners will damage threaded inserts. Refer to the list of required tools when performing disassembly and replacement.

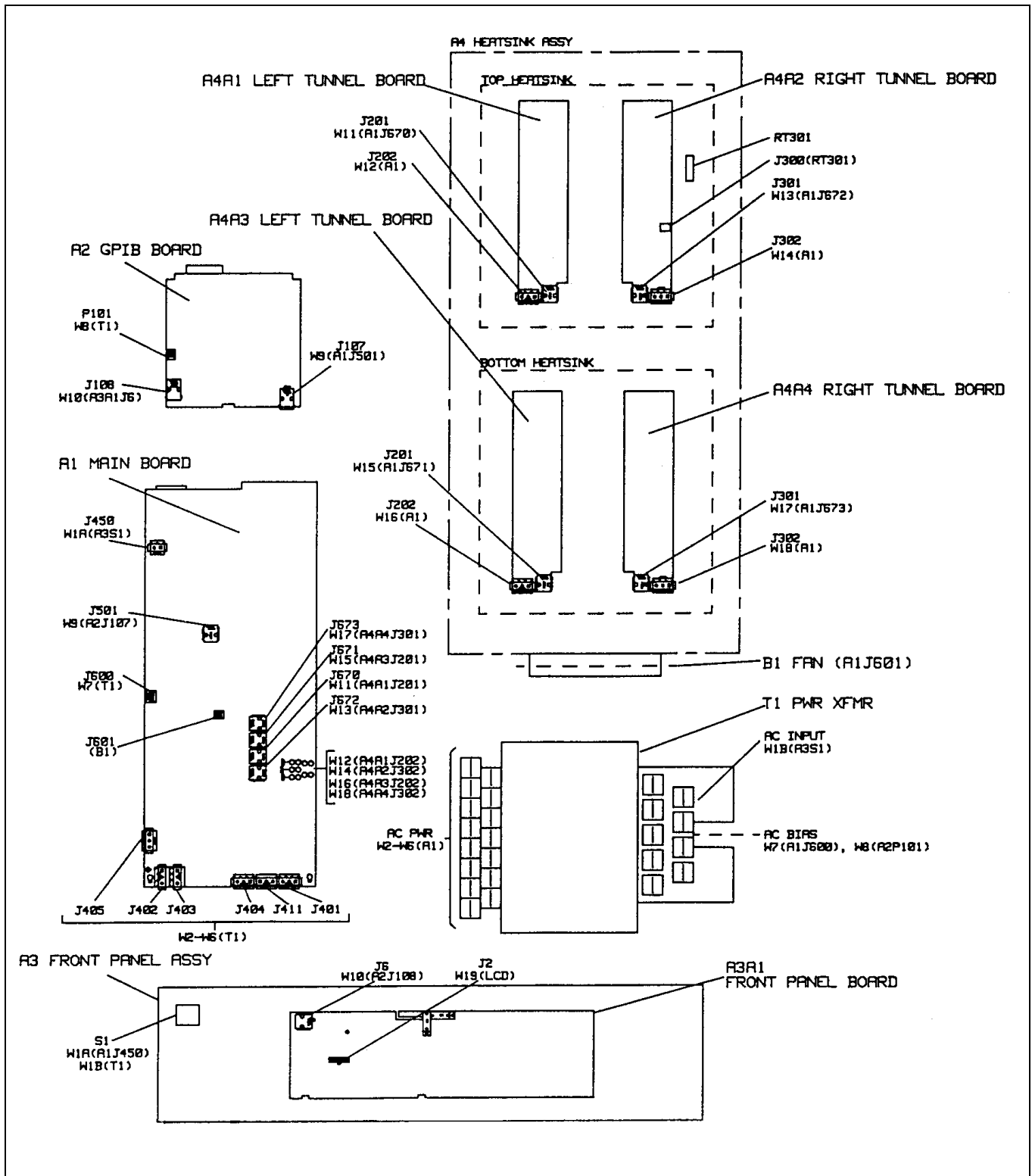

Figure 3-18. Location of Cable and Connector Locations for 655xA and 665xA Models Only

List of Required Tools

- a. IPT and 2PT Pozidriv screwdrivers.
- b. T10, T15 and T25 Torx screwdrivers.
- c. Allen wrench, 0.050 inch.
- d. Hex driver, 7 mm.
- e. Long nose pliers.
- f. Antistatic wrist discharge strap.

Top Cover, Removal & Replacement

- a. Using a T25 Torx screwdriver, unscrew the two screws which hold the carrying straps to the power supply, and then remove the other two screws from the opposite side of the case.
- b. To remove the cover, you must first spread the bottom rear of the cover and then push the cover back to disengage it from the front panel.
- c. Slide the cover backward until it clears the rear of the power supply.

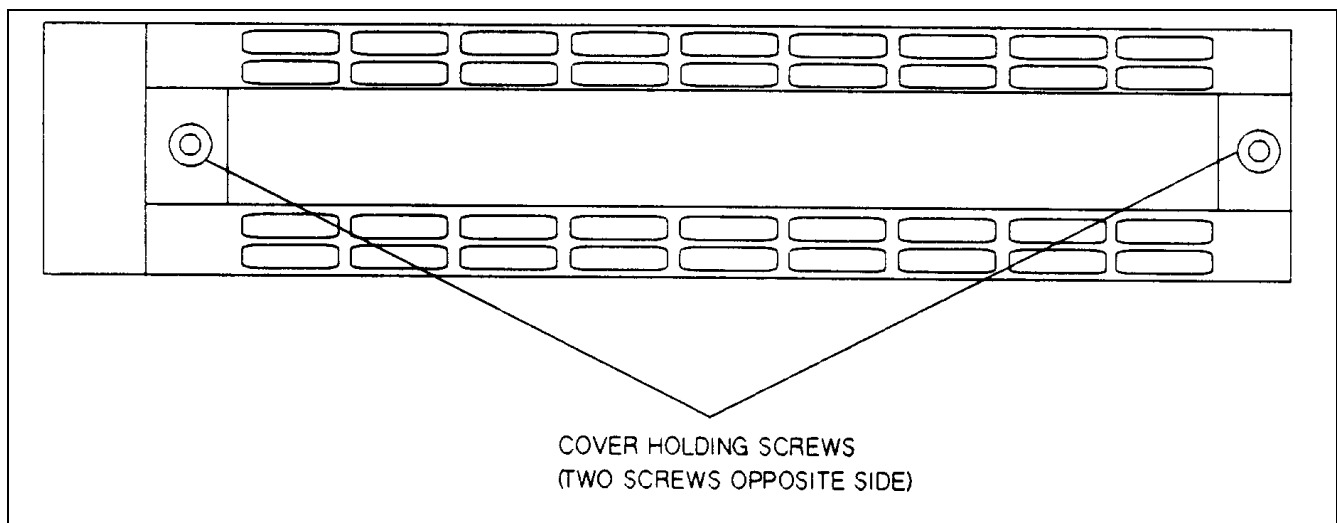

Figure 3-19. Location of Carrying Strap Restraining Screws, Power Supply Side View

A2 GPIB Board, Removal & Replacement (for 664xA & 665xA Models Only)

To remove the GPIB board, proceed as follows:

- a. Remove the top cover of the power supply as described under, "Top Cover Removal and Replacement ."
- b. At the rear of the power supply, remove the protective standoff piece (directly above the AC power receptacle).
- c. Remove the two (2) 7 mm, hex screws that hold the GPIB connector in place.
- d. At the rear of the supply, remove the two (2) screws that hold the HB-IB board to the chassis .
- e. From the top of the power supply, disconnect the phone cable at connector J107 on the GPIB board (the other end of this cable goes to the main board).
- f. Disconnect the phone cable at connector J108 on the GPIB board (the other end of this cable goes to the front panel board).
- g. Disconnect connector P101 on the GPIB board (the other end of this cable goes to the transformer secondary).
- h. Remove the GPIB board from the power supply by gently pulling back on the metal holding clip that holds the front end of the GPIB board in place.
- i. To reinstall the GPIB board, perform the above steps in reverse order.

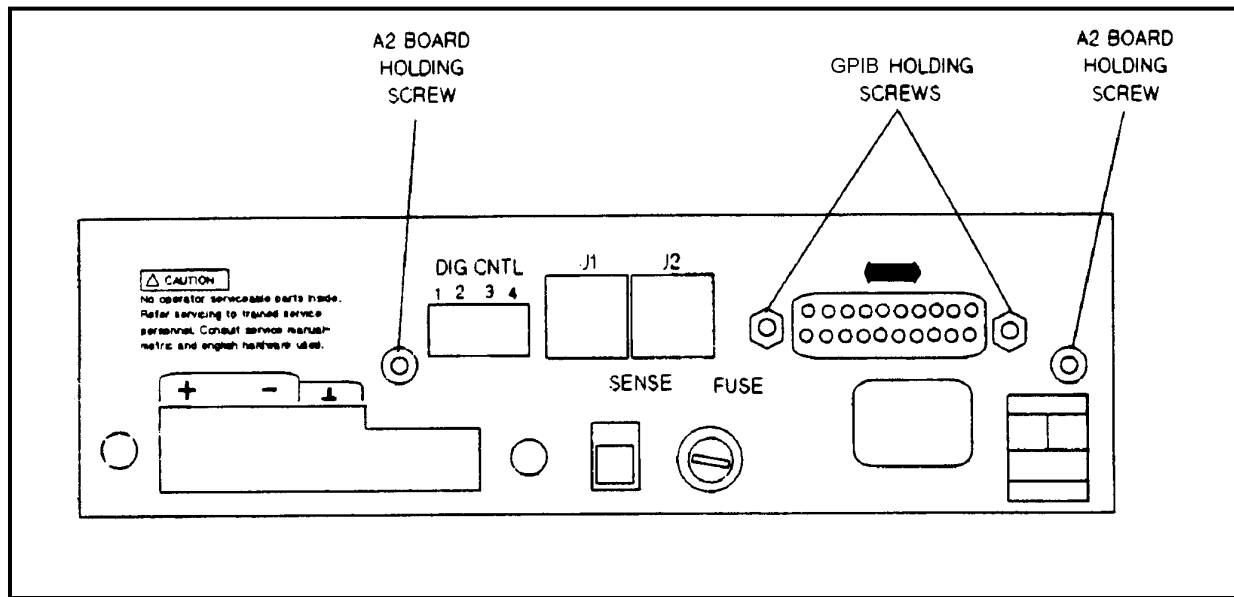

Figure 3-20. GPIB Connector and GPIB Board Holding Screws, Power Supply Rear View

A2 Isolator Board, Removal & Replacement (for 654xA & 655xA Only)

To remove the Isolator board, proceed as follows:

- a. Remove the top cover of the power supply as described under, "Top Cover Removal and Replacement."
- b. At the rear of the power supply, locate and remove the two (2) screws that hold the Isolator board to the chassis. You may need to hold the nuts for these screws stationary while you unscrew the screws. The nuts are on the inside of the chassis.
- c. From the top of the power supply, disconnect the phone cable from connector J800 on the A2 board (the other end of this cable goes to the main board).
- d. Disconnect the phone cable from connector J801 on the A2 board (the other end of this cable goes to the front panel board).
- e. Disconnect connector from J803 on the A2 board (the other end of this cable goes to the transformer secondary).
- f. Remove the A2 board from the power supply.
- g. To reinstall the Isolator board, perform the above steps in reverse order.

Front Panel Assembly, Removal and Replacement

This procedure removes the front panel assembly from the power supply.

- a. Remove the Power Supply Cover as described earlier in, "Top Cover Removal and Replacement . "
- b. Locate and carefully peel off the vinyl trim (one strip on each side of front panel assembly) to gain access to the side screws that secure the front panel assembly to the chassis.
- c. Using a T10 Torx screwdriver, unscrew the screws from the side of the front panel.
- d. Disconnect the phone cable from connector J6 on the A3 board (the other end of the cable goes to the A2 board).
- e. Now move the front panel assembly forward a few inches away from the chassis to gain access to the S1 power switch.
- f. Disconnect the wires going to the S1 switch assembly and note the color coding of the wires and the respective pins to which they connect for subsequent reconnection.
- g. The front panel assembly can now be removed from the power supply.
- h. To reinstall the front panel assembly, perform the above steps in reverse order.

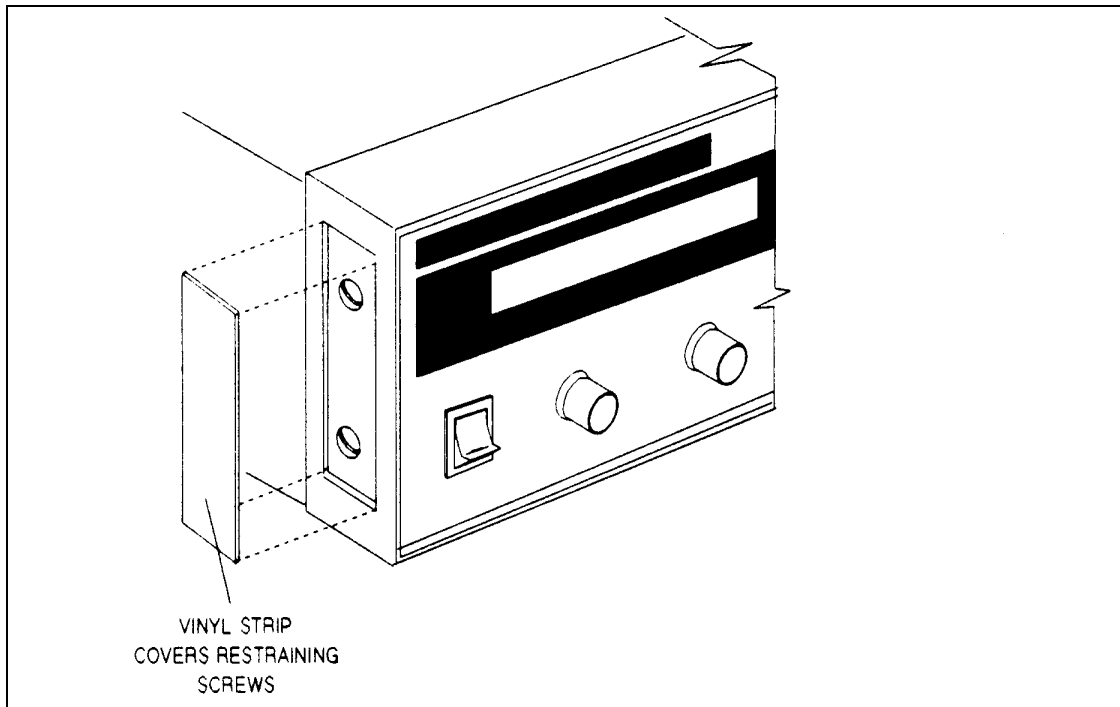

Figure 3-21. Removing Vinyl Strip from Sides of Front Panel Assembly

S1 Line Switch, Removal and Replacement

- First remove the front panel assembly as described under, "Front Panel Assembly, Removal and Replacement".
- On the front panel assembly, release the switch locking tabs by pressing them inward against the body of the switch, and then remove the switch.

Note When re-installing this switch be sure that the screened letter "O" is at the top of the switch.

A3 Front Panel Board, Removal and Replacement

First remove the front panel assembly as described under, "Front Panel Assembly, Removal and Replacement". Once you have access to the front panel board perform these steps:

Note Be careful not to unscrew the knob set screws too far out as they can easily fall out of the knob and become lost.

- Use a small allen wrench (0.050") to loosen the set screws inset in the knobs. Remove knobs and shaft bushings.
- Remove the holding screw (if installed) that secures the board to the front panel assembly. The screw is located near J4 on the front panel board.
- In order to remove the board itself from the assembly you must slide the board to the left to disengage the holding clips. To do this, first lift up the restraining tab on the circuit board and then slide the board to the left and lift it out.
- Disconnect display ribbon connector J2. (The other end of this cable goes to the display panel. DO NOT remove cable at display end.)

Note When reinstalling the front panel board, be sure to line up the "stripe" of the ribbon cable with pin 1 on J2.

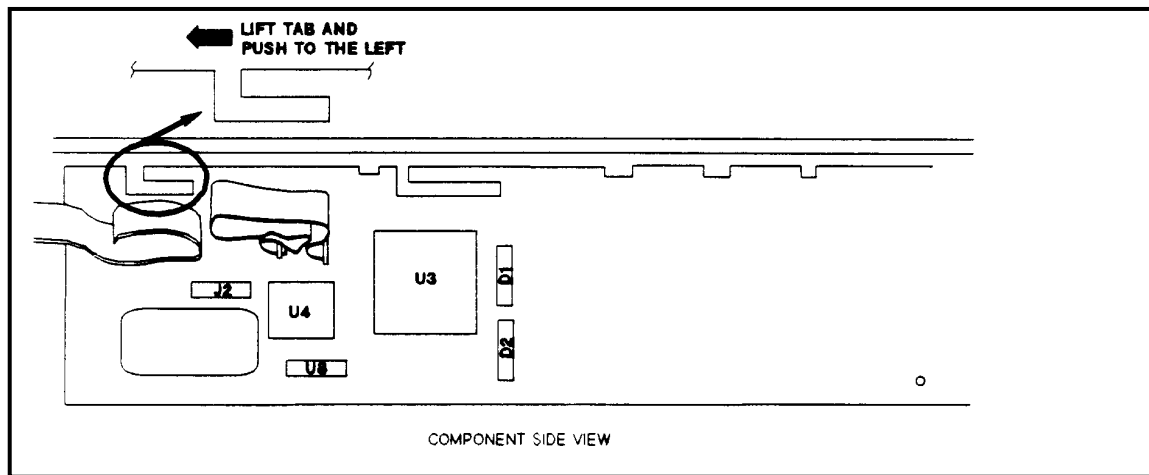

Figure 3-22. Location of Front Panel Board Holding Screw and Restraining Tab

A1 Main Board

- a. Remove the top cover and the A2 board (Isolator or GPIB board).
- b. Disconnect all cables going to connectors on the main board.

Note Be sure to mark any or all cables prior to removal so that no mistake is made later when reinstalling these cables.

- c. Disconnect the ground wire between the main board and the chassis. (This wire is secured to the side of the chassis near the AC input).
- d. For 500 watt 6x5xA models only:
 - Disconnect the following DC power cables from connectors on the tunnel boards which are located on Heat Sink Assembly A4:
 - Cables W12 and W14 from J202 on the top left tunnel board (A4A1) and bottom left tunnel board (A4A2), respectively.
 - Cables W16 and W18 from J302 on the top right tunnel board (A4A3) and bottom right tunnel board (A4A4), respectively.
- e. Remove two screws (one on each side, near J691 and J450, respectively) which secure the main board to the chassis.
- f. Slide the main board towards the front panel to release it from six chassis mounted standoffs and then lift the board out of the chassis.

A4 Heatsink Assembly (500 Watt Models 6x5xA Only)

This assembly is comprised of a top heatsink with left (A4A1) and right (A4A3) tunnel boards, a bottom heatsink with left (A4A2) and right (A4A4) tunnel boards, and a bracket that secures the heatsink and the cooling fan in the chassis. The top heatsink assembly slides over and is held by tracks on the bottom heatsink assembly. The bottom heatsink assembly slides over and is held by tracks on insulated blocks at the bottom of the chassis. To disassemble the heatsink assembly, proceed as follows:

- a. Remove the rear panel.
- b. Remove the plastic insulator (between the rear panel and the heatsink assembly). Remember to replace this insulator when you reassemble the heatsink.

- c. Disconnect cables W11/W12 and W15/W16 from connectors J201/J202 and J301/J302 on top left and on top right tunnel boards, respectively.
- d. Remove the top heatsink assembly and the attached tunnel boards by sliding the top assembly towards the rear and off of the bottom heatsink assembly. Remove the plastic insulator (between heatsink/fan bracket and the heatsink assembly). Remember to replace this insulator when you reassemble the heatsink.
- e. Disconnect cables W13/W14 and W17/W18 from connectors J201/J202 and J301/J302 on the bottom left and on the bottom right tunnel boards.
- f. Remove the bottom heatsink assembly and the attached tunnel boards by sliding the bottom assembly towards the rear of the insulated blocks in the chassis.

A4A1 or A4A3 Left Tunnel Board, Removal and Replacement

To separate a left tunnel board from its heatsink, proceed as follows:

Note	If desired, you can replace a heatsink mounted transistor (Q201, Q203, Q205 and Q207) without separating the board from the heatsink. Apply a thermal compound to the heatsink/insulator when replacing the transistors.
-------------	--

- a. Remove the heatsink assembly as described above.
- b. Remove the screws (two each) securing transistors Q201, Q203, Q205, and Q207 to the heatsink assembly and the left tunnel board.
- c. Unplug each transistor from the socket on the board and separate the board from the heatsink. Note that transistor Q205 is insulated from the heatsink. Be sure that insulator is installed before replacing Q205.

A4A2 or A4A4 Right Tunnel Board

To separate a right tunnel board from its heatsink, proceed as follows:

Note	If desired, you can replace a heatsink mounted transistor (Q301, Q303, Q305, or Q307) without separating the board from the heatsink. Apply a thermal compound to the heatsink/insulator before you replace any transistors.
-------------	--

- a. Remove the heatsink assembly as described above. If you are separating the board from the top heatsink assembly, unplug the thermistor cable from the J300 connector on the board.
- b. Remove the screws (two each) securing transistors Q301, Q303, Q305, and Q307 to the heatsink assembly and the right tunnel board.
- c. Unplug each transistor from the socket on the board and separate the board from the heatsink assembly.

B1 Fan, Removal and Replacement

Remove the top cover as described under, "Top Cover Removal and Replacement".

- a. Disconnect the fan cable from J601 on the A1 main board.
- b. For 500 watt 6x5xA models only, remove the A4 heatsink assembly as described previously.
- c. Remove the screws securing the fan to the heat sink assembly and remove the fan.

T1 Power Transformer, Removal and Replacement

To remove the power transformer, the front panel assembly must first be removed to gain access to the bracket screws that hold the transformer in place. For 654xA and 664xA models, the A1 Main Board must also be removed. Refer to "A1 Board and Front Panel Assembly, Removal and Replacement" Instructions as required. Once the front panel assembly (and also A1 main board for 200 Watt models) is removed, proceed as follows:

- In the supply chassis, remove the two screws (three screws for 6x4xA) securing the transformer to the bottom of the chassis.
- At the front of the chassis, remove the two screws securing the transformer to the chassis.
- Use long nose pliers to disconnect all wires going to the transformer terminals.
- Lift the transformer out of the chassis.

Note The AC power connections at the transformer secondary are model dependent. Be sure to note the color code of the wires and the respective terminals the wires connect to for subsequent reconnection.

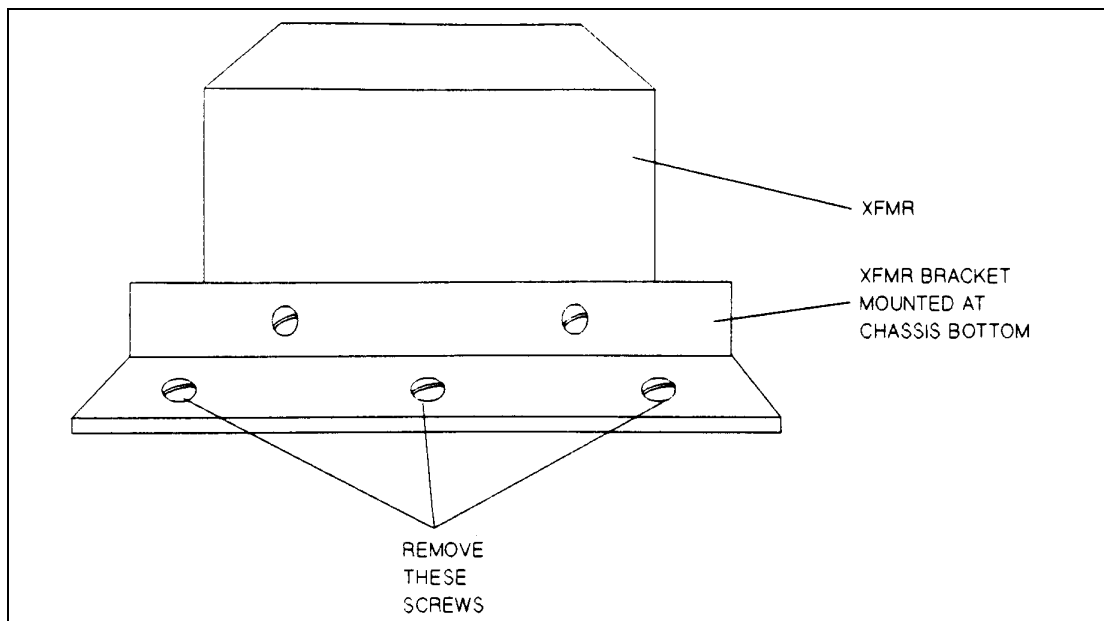

Figure 3-23. Location of XFMR Holding Bracket at Bottom of Chassis

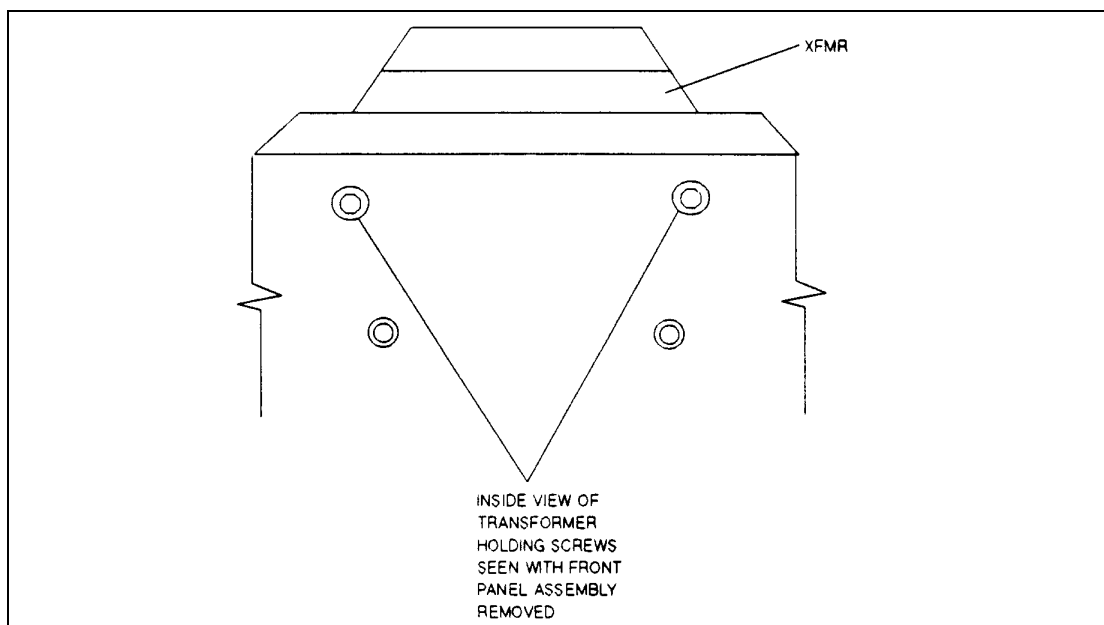

Figure 3-24. Location of XFMR Holding Screws, Inside View

Principles of Operation

Introduction

This section describes the different functional circuits used in the power supply models covered in this manual. The topics are presented in the following order: First, the I/O external signals that connect to the Keysight power supply are described. Next, the overall block diagram for the power supply is described, and last, each functional block shown in the overall block diagram is discussed in detail.

I/O INTERFACE SIGNALS

Figure 4-1 shows the interface signals between the power supply and the end user (or other external circuits and devices). Table 4-1 describes these interface signals.

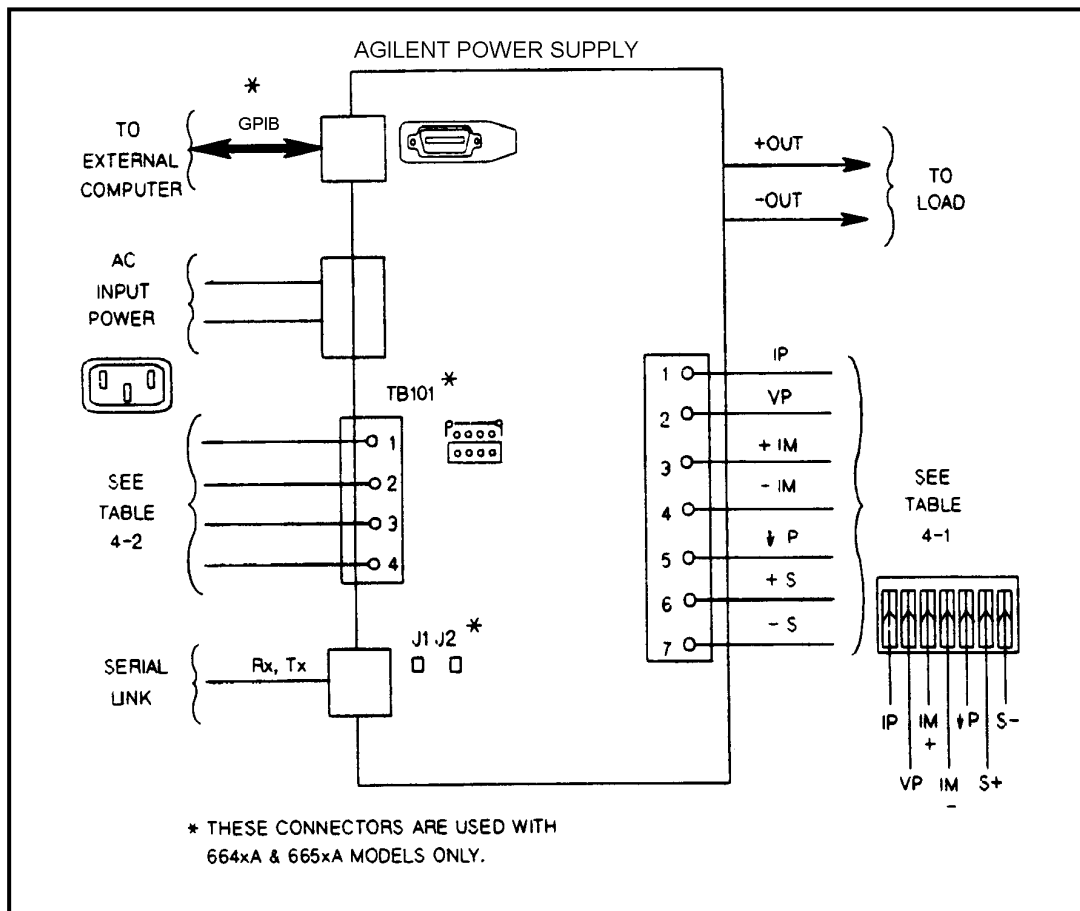

Figure 4-1. Keysight Power Supply, I/O Interface Diagram

Table 4-1. Power Supply Interface Signals

Pin	Signal	Description
Output Power Connections¹		
Busbar or terminal strip screw terminals	+OUT	Positive DC output voltage
	-OUT	Negative DC voltage (or return)
7-Pin I/O Analog Connector		
Pin 1	IP	Current Programming
Pin 2	VP	Voltage Programming
Pin 3	+Imon	External Current Monitor
Pin 4	-Imon	External Current Monitor
Pin 5	↓P	Programming Common
Pin 6	+S	+Sensing Terminal ²
Pin 7	-S	-Sensing Terminal
Rx/Tx Serial Link (Used with GPIB Models 664xA and 665xA only)³		
J1 and J2 Connectors wired in parallel (daisy chain fashion)	3-lines; Rx, Tx, and common signals for both J1 and J2 connectors.	J1 and J2 are telephone connectors.
AC Input Power Source		
AC power connector, J451	Can be 100 V AC, 120 V AC, 220 V AC or 240 V AC	Input AC power
TB101 Digital Control (DIG CNTL) for 664xA and 665xA Models only		
Pins 1 through 4	Pins 1 through 4 can supply one of three sets of signals	See Table 4-2 for these I/O signals and pin destinations.
GPIB Interface Connector (Used With Keysight Models 664xA and 665xA only)		
GPIB	IEEE multi-pin connector signals. See Chapter 6, Figure 6-3, Sheet 2 (Zone 8A) for these signals.	IEEE 488 type connector provides the interface between an external computer and the GPIB board.

¹ For the 500 watt Keysight 655xA and 665xA models, the +OUT and -OUT signals connect to bus-bar type, screw terminals . For the 200 watt Keysight 654xA and 664xA models, these connections are made at a terminal strip on the power supply.

² A switch on the A1 Main Board selects either "Remote" sensing or "Local" sensing of the output voltages (+OUT and -OUT) leads to be monitored.

³ The Rx and Tx serial link permits up to 16 Keysight power supplies to be connected in a daisy chain fashion, each with its own unique programmed device address. One GPIB address with other units being subaddressed.

Table 4-2. Digital CNTL Signals

	PIN	Digital I/O	Relay Link	Fault/Isolation
Pin 1		OUT 0	RLY SEND	FLT Output
Pin 2		OUT 1	NC	FLT Common
Pin 3		IN/OUT 2	RLY RTN	INH Input
Pin 4		Common	Common	INH Common

Overall Block Diagram (Figure 4-2)

All of the Keysight Technologies power supplies covered in this service manual consist of four major functional circuit groups. They are:

1. Secondary Interface Circuits on the A1 Main Board. .
2. Output Power and Control Circuits on the A1 Main Board.
3. A3 Front Panel Board Circuits (part of the Front Panel Assembly).
4. Either the A2 GPIB Board Circuits (primary interface) for models 664xA and 665xA, or the A2 Isolator Board Circuits for models 654xA or 655xA.

In addition, for all models, the primary power transformer is mounted inside and at the bottom of the power supply chassis.

Note the following comments regarding circuit differences in Figure 4-2.

1. In the 200 watt models (654xA and 664xA), the heat sink assembly is part of the A1 main board. But, in the 500 watt models (655xA and 665xA), the heat sink assembly is external to the A1 Main Board mounted at the bottom of the power supply chassis itself.
2. In the 200 watt models (654xA and 664xA), separate switches located on the main board are used to set the appropriate input AC voltage. In the 500 watt models (655xA and 665xA), appropriate wire connections at the power transformer are set according to the applied input AC voltage.
3. In models 664xA and 665xA, the A2 Board is the GPIB board, and a GPIB interface connector is used to transfer data between the power supply and an external computer. In models 654xA and 655xA, the A2 Board is the A2 Isolator Board and the GPIB connector (primary interface) is not applicable.
4. Other differences across Keysight models are described in the text.

Detailed Block Diagram Discussion

The simplified block diagrams in this section show the major signals between circuits. The simplified block diagrams also show the reference designations of the components that comprise a functional circuit. These same reference designators are shown in the schematic diagrams in Section 6.

Secondary Interface Circuits (Figure 4-3)

The secondary interface circuits are also located on the A1 main board. These circuits include a secondary microprocessor, programmed GAL, three DAC/Op amp circuits, and analog comparator circuits. The secondary microprocessor translates the serial data received from the A2 board into a parallel 12-bit data bus. The data bus is connected directly to three DAC/Op amplifier circuits. Under control of the microprocessor, the selected DAC converts the data on the bus into an analog signal. The DAC reference circuit provides a +10 V Ref for the CV and CC DACs, and a -11.5 V Ref for the readback DAC.

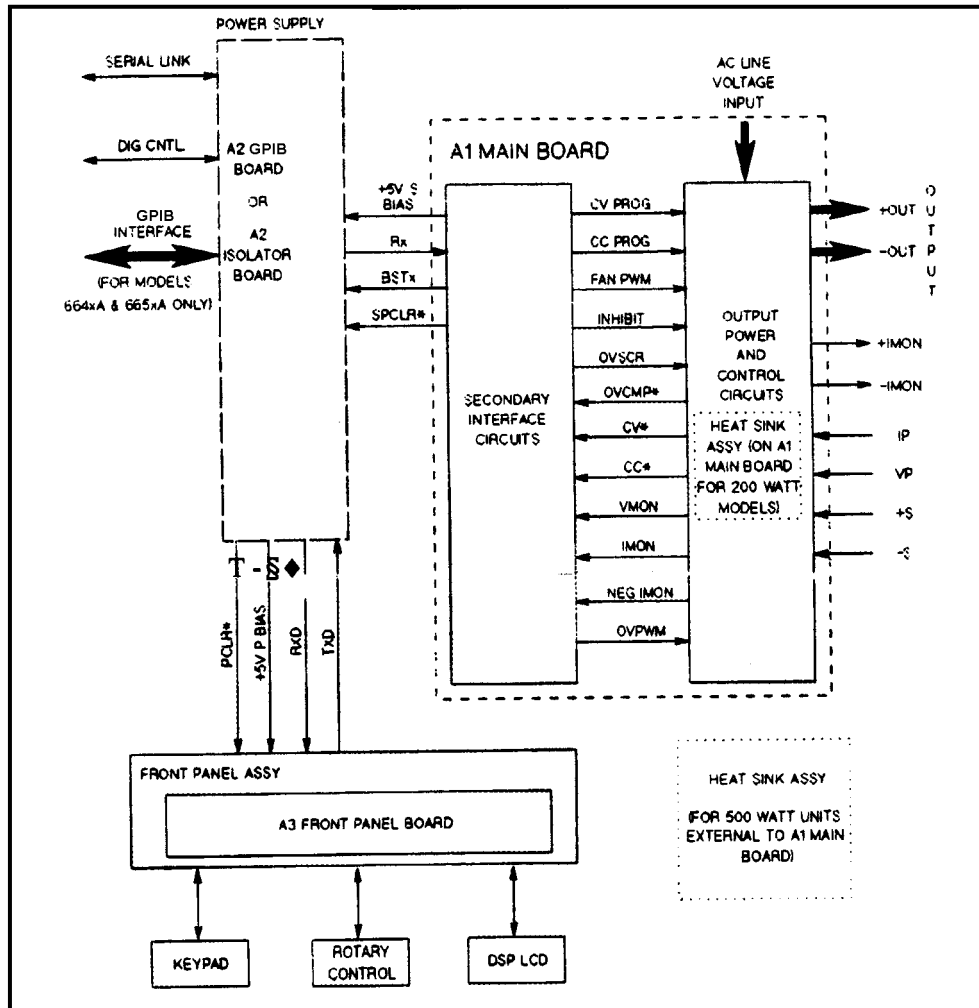

Figure 4-2. Overall Block Diagram

The CV DAC/Op amplifier converts the programmed value of voltage on the bus into the CVPROG signal, which is sent to the CV control circuits in order to control the magnitude of the output voltage in the CV mode. The CVPROG signal is in the 0 to -10 V range, which corresponds to the zero to full-scale output voltage range of the supply.

The CC DAC/Op amplifier converts the programmed value of current on the bus into the CCPROG signal, which is sent to the CC control circuits in order to control the magnitude of the output current in the CC mode. The CCPROG signal is in the 0 to -10 V range, which corresponds to the zero to full-scale output current range of the supply.

The comparator circuits, in conjunction with the readback DAC/Op amplifier, return the following signals to the microprocessor (see Figure 4-3):

- Monitored output voltage (VMON).
- Monitored output current (IMON).
- Negative monitored output current (NEG IMON).
- Ambient temperature (THERM AMB).
- Heat sink temperature (THERM HS).
- Programmed voltage value (CVPROG).
- Programmed current value (CCPROG).

The readback DAC circuit is controlled by the microprocessor to successively approximate the value of each signal monitored to twelve-bit resolution. The CVPROG and CCPROG signals are used during the self test to check operation of the DAC/Op amplifier circuits.

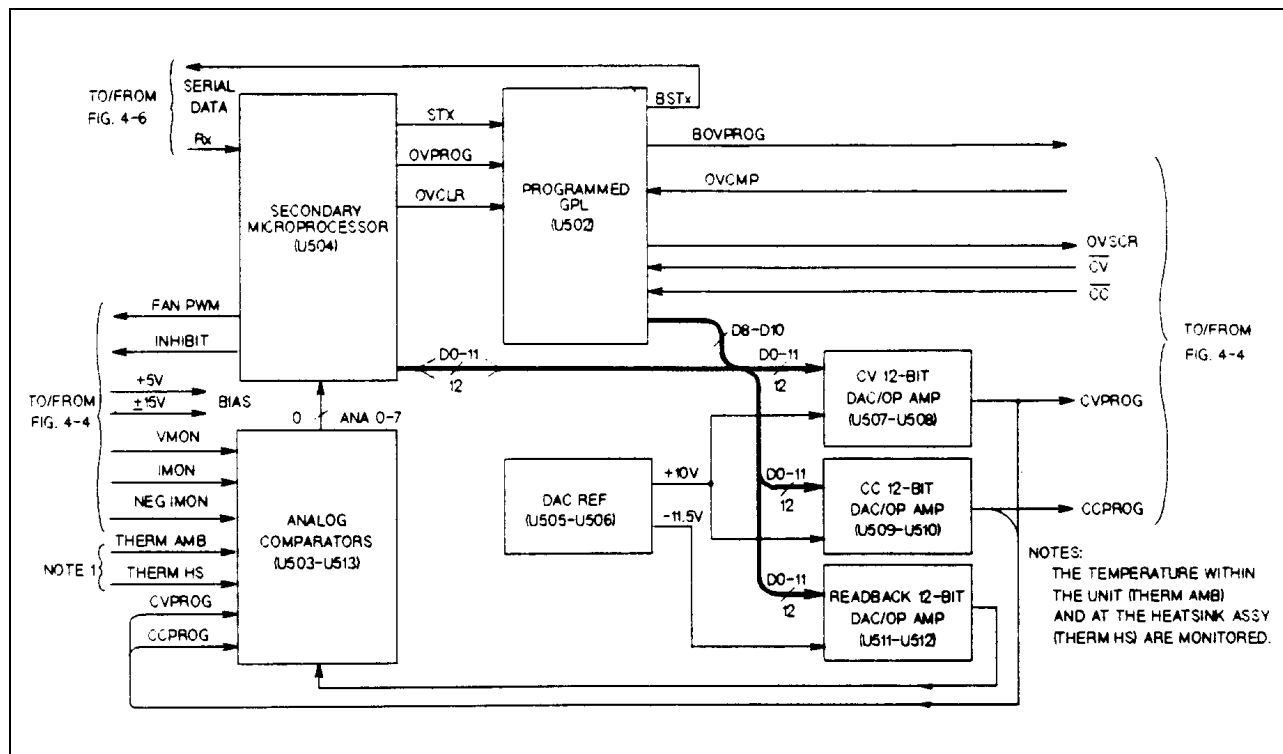

Figure 4-3. Secondary Interface, Simplified Block Diagram

The microprocessor produces the FAN PWM signal, whose pulse width is varied depending upon the ambient temperature. The FAN PWM signal is applied to the fan speed control circuit in order to speed up the fan as temperature increases, and to slow the fan speed down as temperature decreases.

The INHIBIT signal is generated by the microprocessor to hold the supply's output off during turn-on and when the supply OV's. The INHIBIT signal is sent to the output stage bias/shutdown circuit in order to shutdown the bias voltage to the output stages, and to keep the supply output off.

The microprocessor produces the OVPROG signal, which is also a pulse-width modulated signal that represents the programmed over voltage protection level. The OVPROG signal is sent to the OV monitor circuit, which compares the actual output voltage level with the OVPROG signal. When the output voltage exceeds the OVPROG signal level, the OV monitor circuit produces a low-level OVCMPL* signal. With OVCMPL* low, the GAL produces a high-level OVSCR signal which is sent to the SCR control and to the output stage bias/shutdown circuits. The high-level OVSCR signal causes the following actions to occur:

- The SCR fires, shorting the supply's output.
- The GATED ± 15 V bias for the output regulators on the tunnel boards is shut down, turning off the output.
- The GAL notifies the secondary microprocessor of the OV condition (OVSCR is high) on data line eleven, in order to display a status update.
- The microprocessor clears the OVSCR signal when it generates the OVCLR signal (output protection clear command is executed).

Output Power and Control Circuits (Figure 4-4)

Output Power

The output power circuits are shown across the top of Figure 4-4. They consist of: power rectifiers, SCR (crowbar), filter capacitors, a current-monitoring resistor on the main board, and regulator and downprogramming stages (on the A4A1-A4A4 tunnel boards for the 500 watt models, and on the main board for the 200 watt models).

For the 500 watt Keysight 655xA and 665xA models, there are two (top and bottom) left tunnel circuits (A4A1 and A4A3) and two (top and bottom) right tunnel circuits (A4A2 and A4A4). The 200 watt Keysight 654xA and 664xA models use one left and one right tunnel circuit. Table 4-3 summarizes these model differences.

Table 4-3. A1 Main Board and Heat Sink Assembly Model Differences

Item	500 Watt Models 655xA & 665xA	200 Watt Models 654xA & 664xA
Heat sink assembly	External to main board	Located on main Board
Tunnel circuits	Two left and two right circuits	One left and one right circuit
Regulator stages	Total of 14 stages	Total of seven stages
Downprogrammers	Total of two	One total

Each left tunnel circuit has three regulator stages and one downprogramming stage. Each right tunnel circuit has four regulator stages. Thus, there are a total of fourteen regulator stages and two downprogramming stages for the 500 watt models, and half this number for the 200 watt models. Each regulator stage consists of an amplifier driver, and one NPN series regulator. Models 6645A, 6545A, 6555A, and 6655A use a MOSFET regulator and no driver.

The output NPN transistor (or MOSFET) of each stage is mounted on the heat sink assembly and is connected between the +RAIL and the inboard side of the current sampling resistor in the +OUT line. The conduction of these output transistors is increased, or decreased, by the OUTPUT CONTROL signal from the CV/CC control circuits in order to regulate the output voltage (CV mode), or the output current (CC mode).

Each downprogramming stage consists of a comparator, transistor driver, and a downprogramming transistor. Each NPN downprogramming transistor is connected between the inboard side of the +OUT line and the -RAIL. The conduction of the downprogramming transistors is controlled by the DP CONTROL signal from the CV/CC control circuits. Conduction is increased when the output is downprogrammed to shunt current away from the load, thus allowing faster downprogramming.

The SCR, connected across the output, will fire and short the output when an overvoltage condition is detected. The SCR is controlled by the OV signal from the SCR control circuit as described under, "Control Circuits."

Resistor R657 monitors the output current.

Control Circuits

The control circuits are shown across the bottom of Figure 4-4 and consist of the CV/CC control, output voltage/current monitor, bias supplies, and SCR control. All of these circuits are located on the A1 main board.

The CV/CC control circuits provide a CV control loop and a CC control loop. For any value of load resistance, the supply must act either as a constant voltage (CV) or as a constant current (CC) supply. Transfer between these modes is accomplished automatically by the CV/CC control circuit at a value of load resistance equal to the ratio of the programmed voltage value to the programmed current value. A low level CV* or CC* signal is returned to the secondary interface to indicate that the corresponding mode is in effect.

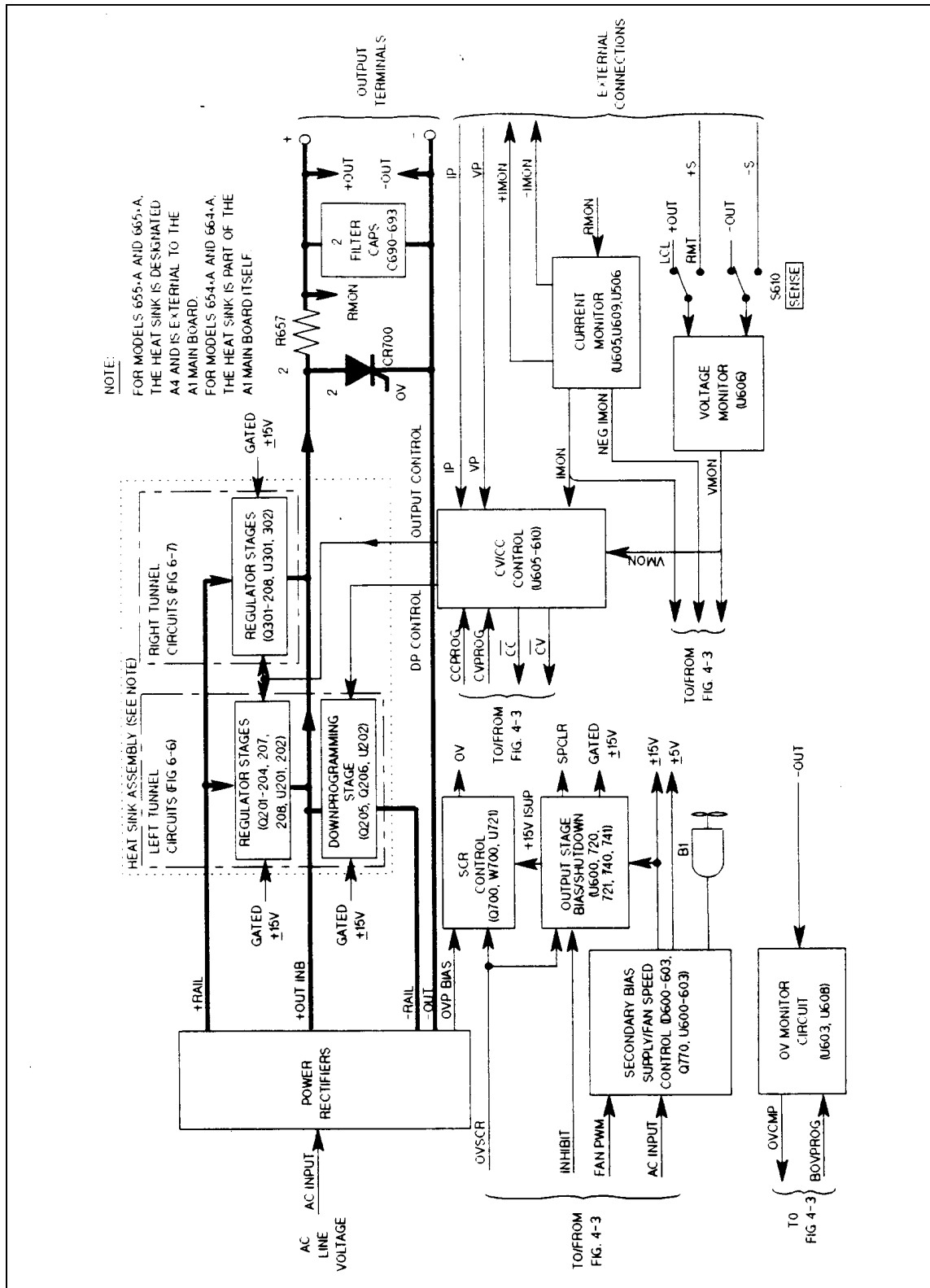

Figure 4-4. Output Power and Control Circuits

With the CV mode in effect, the CV loop will regulate the output voltage. The CV control circuit compares the programmed voltage signal CVPROG (0 to -10 V range) with the output voltage monitor signal VMON. The VMON signal is in the 0 to +10 V range which corresponds to the zero to full-scale output voltage range of the supply. If the output voltage exceeds the programmed voltage, the OUTPUT CONTROL signal goes low, causing the output transistor to conduct less and decrease the output voltage.

Conversely, if the output voltage is less than the programmed voltage, the OUTPUT CONTROL signal goes high, causing the output transistors to conduct more and increase the output voltage. Depending upon the position of the SENSE switch, the output voltage is either monitored at the supply's output terminals (local), or at the load (remote), using the +S and -S terminals with remote sense leads connected to the load. If the output voltage goes higher than the programmed value, the downprogramming stage is turned on.

Note that an external signal VP can be used to program the output voltage in the CV mode. A 0 to -5 V externally applied signal produces a proportional output voltage from zero to full scale. VP is summed with the CVPROG and VMON signals.

With the CC mode in effect, the CC loop regulates the output current. The CC control circuit compares the programmed current signal CCPROG (0 to -10 V), with the output current monitor signal (IMON).

The IMON signal is produced by measuring the voltage drop across current monitoring resistor R657 (RMON). The IMON signal is in the 0 to +10 V range, which corresponds to the zero to full-scale output current range. If the output current exceeds the programmed value, the OUTPUT CONTROL goes low, causing the output transistors to conduct less and thus decrease the output current.

Conversely, if the output current is less than the programmed value, the OUTPUT CONTROL signal goes high, causing the output transistors to conduct more and increase the output current. Note that the external signal IP can be used to program the output current in the CC mode. A 0 to -5 V externally applied signal produces a proportional output current from zero to full scale. IP is summed with the CCPROG and IMON signals. When the power supply is programmed down (in the CV or CC mode), the CV/CC control circuit causes the DP CONTROL signal to go low, which in turn causes the downprogramming transistors to conduct current away from the load and speed up downprogramming.

The secondary bias supply generates the +5 V and ± 15 V bias voltages for the secondary interface circuits and for the CV/CC control circuits. The ± 15 V is also sent to the output stage bias/shutdown circuit.

When power is initially applied, a secondary power clear signal (SPCLR) is generated to initialize the secondary interface circuits. The output stage bias/shutdown circuit holds off the output until the secondary bias voltages have time to stabilize. After a delay of 40 ms, the ± 15 ISUP signal is generated, and the GATED ± 15 V bias is enabled, allowing the output regulator stages to be turned on.

During operation, the output stage bias/shutdown circuit will turn off the GATED ± 15 V bias voltages, and will shut down the output if any of the following occur:

- The output is programmed off.
- An over voltage condition is detected (OVSCR signal is received).
- The line voltage falls below 90 volts (approximately).
- The INHIBIT signal is received.
- A secondary bias supply failure occurs.

The SCR control circuit is enabled when the ± 15 ISUP signal is received. When an over voltage condition occurs (OVSCR signal is generated as described previously), the SCR control circuit generates the OV signal, which in turn fires the SCR, thus shorting the output of the supply.

The fan speed control circuit, included in the functional circuit block with the secondary bias supply, provides the DC voltage to operate the cooling fan. The FAN PWM (pulse width modulated) signal from the secondary microprocessor varies this voltage according to the ambient temperature and the output current of the supply.

A3 Front Panel Board Circuits (Figure 4-5)

The supply's front panel assembly contains a circuit board, a keypad, a liquid crystal display (LCD), and rotary controls (A3G1 and A3G2) for the output voltage and current. The on/off switch, not shown in Figure 4-5, is also located on the front panel. The same front panel board is used in all Keysight models.

The front panel board (A3) contains microprocessor circuits (microprocessor and ROM chips), which decode and execute all keypad commands which are transferred to the power supply output, via the serial I/O port to the A2 board (GAL chip and isolators), and to the secondary interface circuits on the A1 main board. The front panel microprocessor circuits also process power supply measurement and status data received on the serial I/O port. This data is displayed on the LCD.

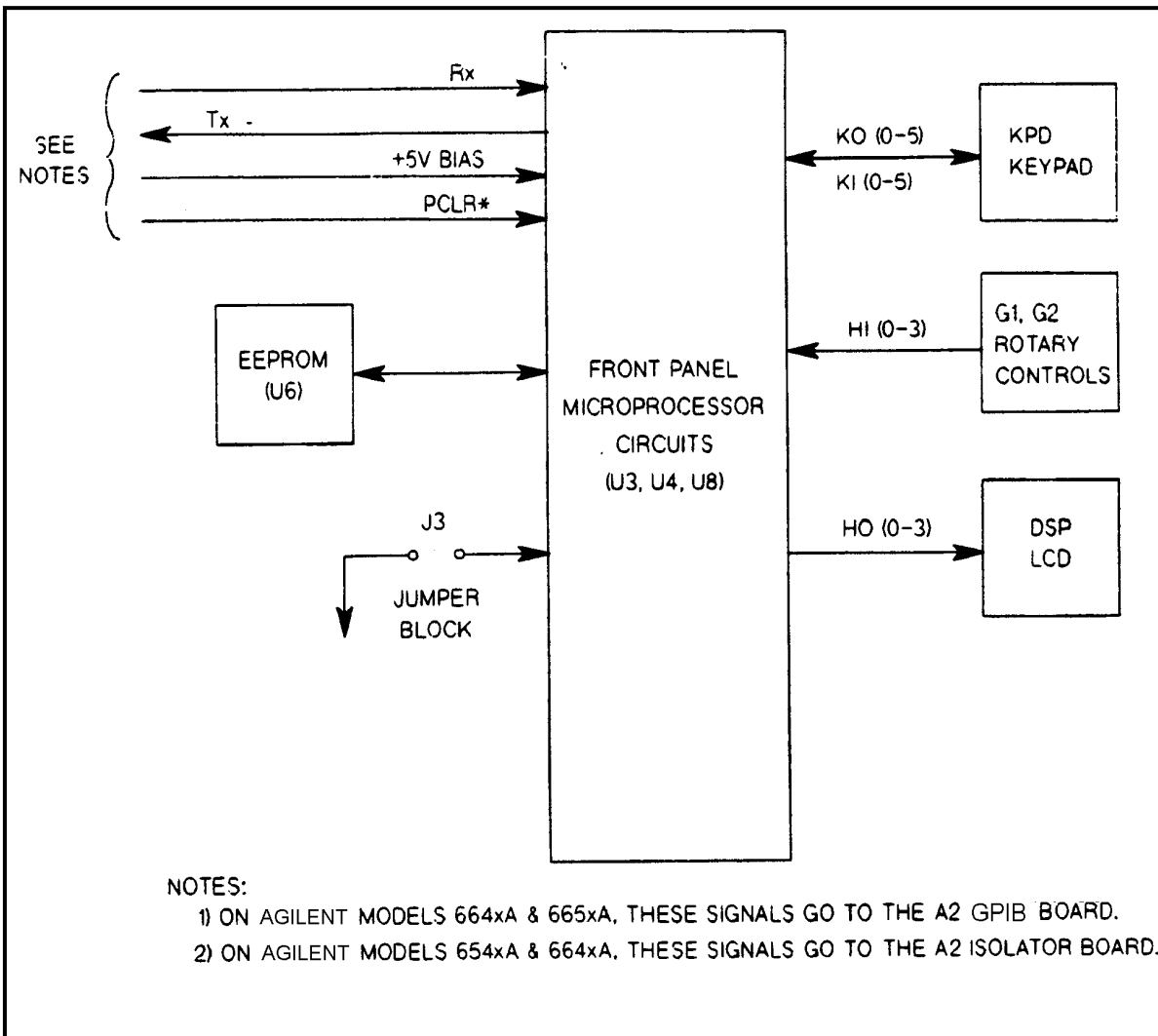

Figure 4-5. Front Panel Board, Simplified Block Diagram

The EEPROM (electrically erasable programmable read-only memory) chip on the front panel board stores a variety of data and configuration information. This information includes calibration constants, GPIB address, present programming language, and model-dependent data, such as the minimum and maximum values of voltage and current. One of the EEPROM storage locations holds a checksum value which is used to verify the integrity of the EEPROM data.

All Keysight models can be calibrated from the front panel. Keysight models 664xA and 665xA can also be calibrated via the GPIB by using SPCI commands (see Appendix A in the Operating Manual). Access to the calibration data in the

EEPROM is controlled by the combination of a password and jumper options on header A3J3, located on front panel board (see Calibration in the Operating Manual). In addition, for models Keysight 664xA and 665xA, the front panel EEPROM can be updated from the GPIB interface, whereas, the memory circuits used in models Keysight 654xA and 655xA cannot be programmed via the GPIB interface.

If the EEPROM should fail in models 654xA and 655xA, two options exist. The first option is to replace the front panel board with another front panel board, having an EEPROM already preprogrammed from the factory. The second option is to reprogram the new EEPROM, using an auxiliary GPIB board, available from the Keysight Technologies Sales and Support Office.

Note The EEPROM for each power supply model is programmed with unique data during initialization.

Jumper block A3J3 is located on the front panel board. This jumper block is strapped differently according to the service testing and/or calibration to be performed. The connections on the A3J3 jumper block are as follows:

FAC CAL	Loads memory with initial factory values from EEPROM for calibration purposes. No password is required (this permits the password requirement to be overridden).
INH CAL	Inhibits calibration.
SA MODE	Used with signature analysis troubleshooting.
NORMAL	Normal operation.

As shipped from the factory, this jumper block is connected for normal operation.

A2 GPIB Board Circuits For Keysight Models 664xA and 665xA Only

The circuits on the A2 GPIB Board (see Figure 4-6) provide the interface between the GPIB controller and the power supply. All communication between the power supply and a GPIB controller is processed by the GPIB interface and the primary microprocessor circuits on the A2 board.

The primary microprocessor circuits (microprocessor, ROM, and RAM chips) decode and execute all instructions and control all data transfers between the GPIB controller and the secondary interface. The primary microprocessor also processes measurement and status data received from the secondary interface.

A UART (universal asynchronous receive/transmit) chip on the A2 board converts the primary microprocessor's 8-bit bus into a serial I/O port.

The serial data is transferred between the primary interface and the secondary interface via a programmed GAL (gated array logic) chip and optical isolator chips. These chips isolate the primary interface circuits (referenced to earth ground) from the secondary interface circuits (referenced to power supply common). The GAL chip also provides a serial I/O port to the front panel, thus allowing the power supply to be controlled from the front panel.

The serial link interface on the A2 GPIB board allows up to sixteen supplies to be connected together and to be programmed from one GPIB address. The first supply is the only supply connected directly to the GPIB controller and is set to the primary GPIB address. The remaining supplies are programmed to secondary addresses and are linked (daisy chained) together via the J1/J2 phone jacks on the rear of each supply.

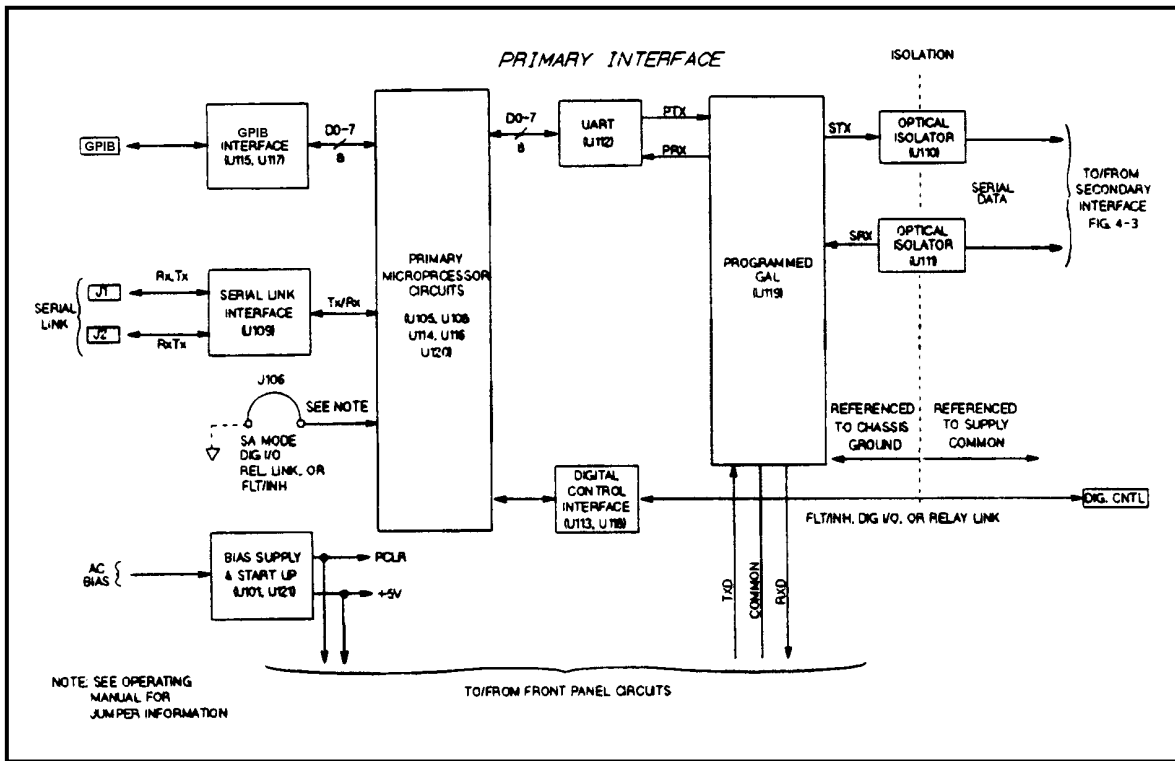

Figure 4-6. GPIB Board, Simplified Block Diagram (Models Keysight 664xA and 665xA Only)

Terminal strip TB101 can be strapped to provide one of four digital input/output control signals (see Table 4-4). The Power Supply Operating Manual describes how to select one of these three sets of signals. As shipped from the factory, this terminal strip is connected for FLT output and INH input. Refer to the Operating Manual for operating instructions.

Table 4-4. TB101 Terminal Strip, Digital CNTL Signals

PIN	Digital I/O	Relay Link	Fault/Isolation
Pin 1	OUT 0	RLY SEND	FLT Output
Pin 2	OUT 1	NC	FLT Common
Pin 3	IN/OUT 2	RLY RTN	INH Input
Pin 4	Common	Common	INH Common

The bias supply (+5 V reference to earth ground) for the primary interface circuits is located on the A2 board. It also provides the bias voltage to operate the circuits located on the front panel board, the LCD, and the keypad. A power clear signal (PCLR) is generated to initialize certain primary interface circuits and front panel circuits when the unit is turned on.

Isolator Board Circuits for Keysight Models 654xA and 665xA Only (Figure 4-7)

The isolator board performs the following two functions:

1. Creates a +5 V bias voltage.
2. Provides isolation between the PCLR, RxD, and TxD front panel signals and similar signals received from the A1 Main Board.

When power is turned on to the power supply, an isolated AC signal from XFMR T1 in the secondary circuits is applied to a +5 V bias supply (U805) on the isolator board. The bias supply produces a +5 V BIAS output voltage that is routed to the front panel circuits.

At the same time, a low SPCLR* level from the secondary circuits is applied to optical isolator circuit, U800. It is then routed as a low PCLR* level to the RESET* input of the front panel microprocessor. This low level keeps the microprocessor temporarily disabled during power turn-on for a short time interval.

After a time delay of 40 ms, SPCLR* goes high and the microprocessor is enabled. By inhibiting microprocessor operation for 40 ms, any erroneous operation (due to a rising but yet unstable +5 V) is prevented until the +5 V BIAS voltage fully settles.

When power is turned off or is removed, SPCLR* goes low immediately and disables the microprocessor in order to provide a graceful shut down of the power supply as the +5 V falls to zero volts. See Figure 4-8 which shows the time delay of the *PCLR signal, which is obtained from the isolated *SPCLR signal.

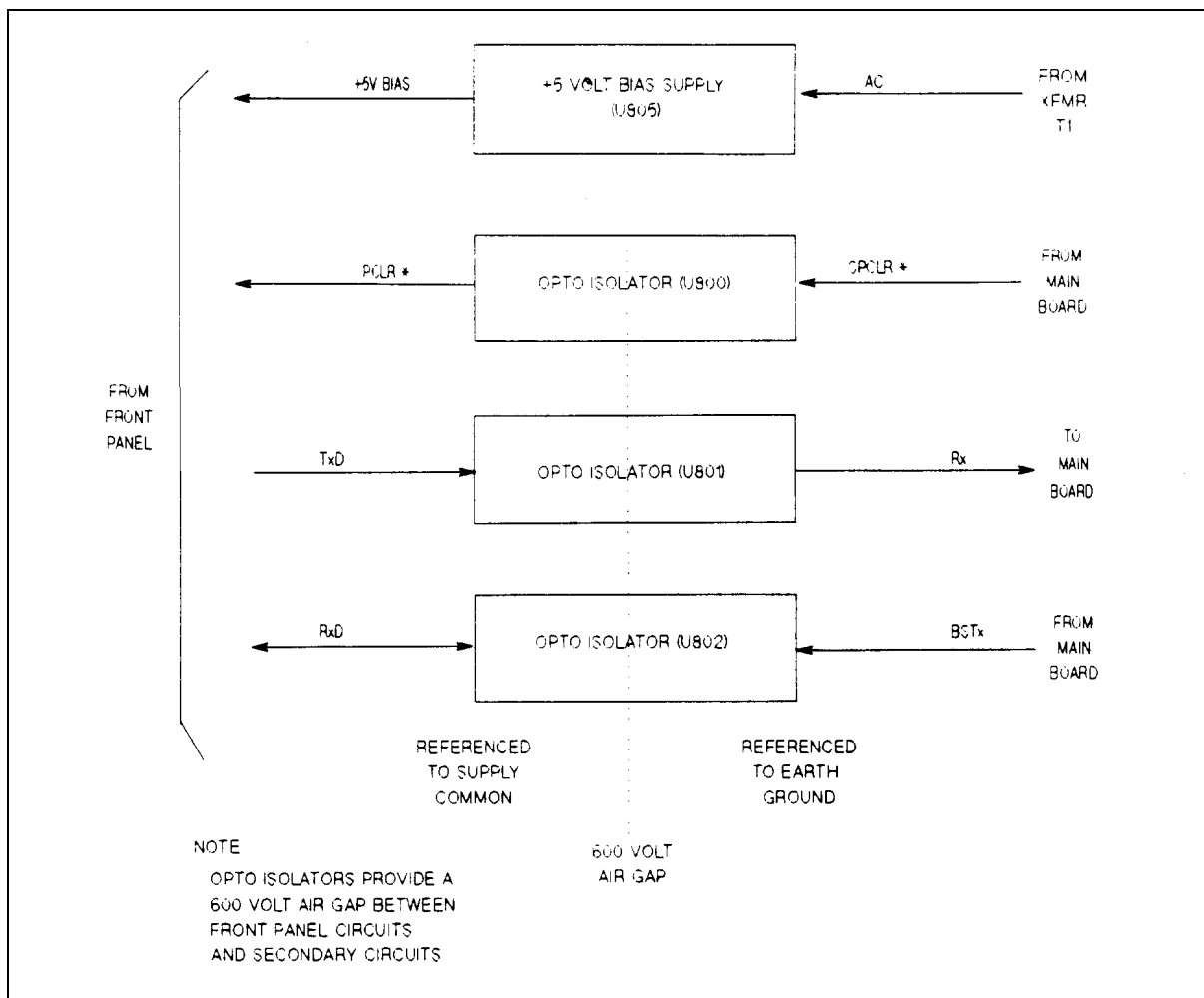

Figure 4-7. Isolator Board, Simplified Block Diagram (Models Keysight 654xA and 655xA)

Note Note that for Keysight 664xA and 665xA models, the PCLR* is generated in the GPIB board. For Keysight models 654xA and 655xA, the PCLR* originates at the main board secondary circuits and is routed to the isolator board.

The isolator board includes three separate optical isolator circuits that isolate the front panel signals: RxD, TxD, and PCLR* signals from the SRx, BSTx and SPCLR* signals at the secondary interface circuits.

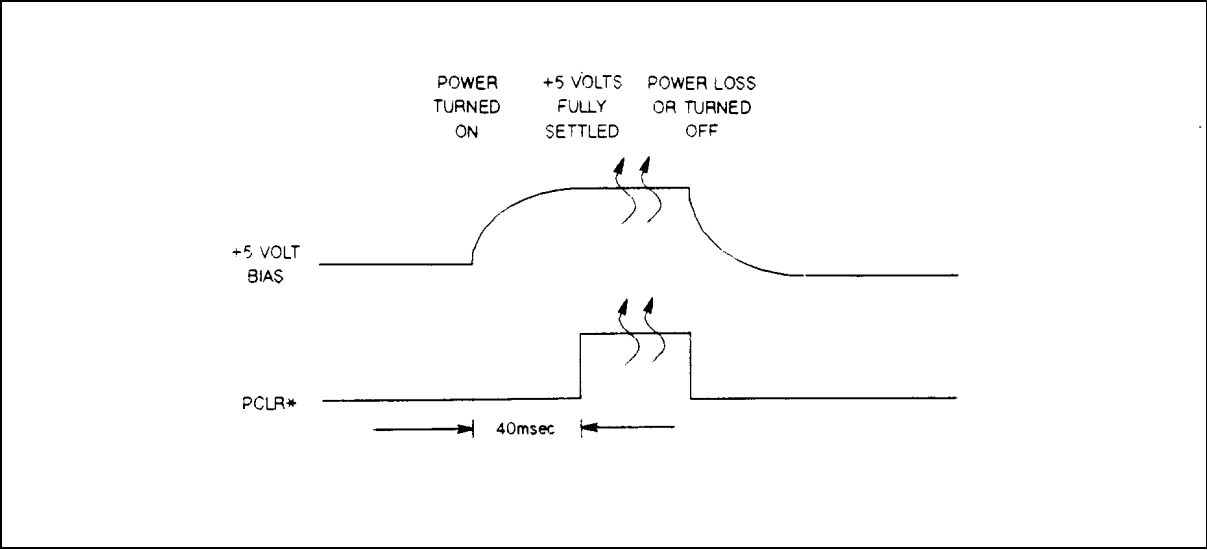

Figure 4-8. +5 V BIAS and PCLR* Timing Sequence

Replaceable Parts

Introduction

Chapter Organization

This section lists the replaceable electrical and mechanical parts for the Keysight 654xA, Keysight 655xA, Keysight 664xA, and Keysight 665xA power supplies. Component location diagrams are located in Chapter 6. Table 5-1 is an index to the different parts list tables.

Table 5-1. Index to Power Supply Assemblies

Assembly	For 200 Watt Models	For 500 Watt Models
Main Chassis	Table 5-4	Table 5-6
A1 Main Board	Table 5-5	Table 5-7
A2 Isolator Board for 654xA & 655xA Only	Table 5-8	Table 5-8
A2 GPIB Board for 664xA & 665xA Only	Table 5-9	Table 5-9
A3 Front Panel Circuit Board All Models	Table 5-10	Table 5-10
A4A1/A4A3 Left Tunnel Board for 655xA & 665xA Only	-	Table 5-11
A4A2/A4A4 Right Tunnel Board for 655xA & 665xA only	-	Table 5-12

Model Applicability

The title of each table in this section indicates the power supply models covered in the table. A separate column called **Applicable Models** indicates when a part is applicable to only specific models. **If no entry appears in the Applicable Models column, then the part applies to all models covered by the table.** See Table 5-2 for reference designators and Table 5-3 for abbreviations.

Table 5-2. Part Reference Designators

A	assembly	J	jack	SW	switch
B	blower (fan)	K	relay	T	transformer
C	Capacitor	L	inductor	TB	terminal block
CR	thyristor/SCR	P	plug	U	integrated circuit
D	diode	Q	transistor	VR	voltage regulator
DSP	display (LCD)	R	resistor	W	cable or jumper
F	Fuse	RT	thermal resistor	Y	crystal oscillator

Table 5-3. Part Description Abbreviations

assy	assembly	M	metric	sq	square	w/o	without
bd	board	mch	machine	submin	subminiature	xfmr	transformer
blvl	belleville	mm	millimeter	thk	thick	xtal	crystal
gnd	ground	mtg	mounting	thrd	thread		
lg	long	PCB	pc board	w/	with		

How To Order Parts

You can order parts from your local Keysight Technologies Sales and Support Office (see the list of offices in the back of this manual). When ordering a part, please include the following information

- the Keysight part number
- the part description
- the desired quantity
- the power supply model number ("Keysight 6545A").

Table 5-4. Main Chassis Replaceable Parts for 200 Watt Models 654xA and 664xA

Reference Desig.	Applicable Models	Keysight Part No.	Description
A1	65/6641A	06641-61030	Mother Board PCA Tested
A1	65/6642A	06642-61030	Mother Board PCA Tested
A1	65/6643A	06643-61030	Mother Board PCA Tested
A1	65/6644A	06644-61030	Mother Board PCA Tested
A1	65/6645A	06645-61030	Mother Board PCA Tested
A2	6541A-6545A	5060-3398	Isolator Board PCA Tested
A2	6641A-6645A	5060-3399	GPIB Board PCA Tested (surface mount, see Table 5-9A)
A2	6641A-6645A	5060-3317	GPIB Board PCA Tested (through-hole, see Table 5-9B)
A3		5060-3400	Front Panel Board Tested but Uninitialized
A3	6541A	06541-61001	Front Panel Board Tested & Initialized
A3	6542A	06542-61001	Front Panel Board Tested & Initialized
A3	6543A	06543-61001	Front Panel Board Tested & Initialized
A3	6544A	06544-61001	Front Panel Board Tested & Initialized
A3	6545A	06545-61001	Front Panel Board Tested & Initialized
		0515-0433	Machine screw, M4 x 0.7 8 mm lg. REF XFMR bracket
		0515-0374	Machine screw, M3 x 0.5 10 mm lg. REF: front frame
		0515-0380	Machine screw, M4 x 0.7 10 mm lg. REF cover, (5) PCB,(1)GN
		0515-0386	Machine screw, M5 x 0.810 mm lg. REF: 2 Cover
		0515-1085	Machine screw REF TERM Cover (2)
		0515-1285	Machine screw REF: Fan Mounting
		0515-1384	Machine screw M5X0.8 REF: 2 Handle
		2190-0016	Lock washer INTL T REF RPG Front Panel Board
		2190-0585	Lock washer HLCL REF Fan mounting
		2190-0586	Lock washer HLCL GPIB Connector
		0380-0643	Nut GPIB Connector
		2190-0646	Lock washer REF ground wire
		3050-0893	Flat washer MTLC REF Isolator PCA
		2950-0043	Hex nut DBL-CHAM REF RPG Front Panel Board
		0535-0023	Hex nut DBL-CHAM REF Isolator PCA self thread
		0590-0534	Nut self-treading REF Display to front panel
		1252-1488	Quick-disconnect mating plug for DIG CNTL connector A2TB10I
		1252-3698	Quick-disconnect mating plug for external connector AIJ640
		5080-2148	Chaining cable for power supply link
		5080-2228	Label rear
		5080-2248	Label instrument
	6541A	06541-80001	Nameplate
	6542A	06542-80001	Nameplate
	6543A	06543-80001	Nameplate
	6544A	06544-80001	Nameplate
	6545A	06545-80001	Nameplate
	6641A	06641-80001	Nameplate
	6642A	06642-80001	Nameplate
	6643A	06643-80001	Nameplate
	6644A	06644-80001	Nameplate
	6645A	06645-80001	Nameplate
		0360-2191	Cover terminal block

Table 5-4. Main Chassis Replaceable Parts for 200 Watt Models 654xA and 664xA(continued)

Reference Desig.	Applicable Models	Keysight Part No.	Description
		0370-3238	Knob Ref RPG
		0370-2862	Pushbutton
		0380-0181	Spacer round .75-IN REF fan mounting
		0380-1524	HEX standoff 8-MM REF Isolator PCA
		0960-0912	Optical encoder, front panel board
		1000-0842	Window
		1531-0309	Clevis
		5062-3974	Rack mounting kit
		5062-3975	Rack mounting kit w/handles
		06632-60002	Fan assembly
		5001-6787	Shim Ref. XFMR MTG
		5001-6788	XFMR bracket
		5041-8801	Foot
	65/6641A	9100-4963	XFMR power bias
	65/6642A	9100-4964	XFMR power bias
	65/6643A	9100-4965	XFMR power bias
	65/6644A	9100-4966	XFMR power bias
	65/6645A	9100-4967	XFMR power bias
		5060-3364	Chassis assembly
P640		1252-3698	Connector
S001		3101-2862	Rocker switch S001
W1		5080-2204	AC cable assembly
W2		5080-2205	Primary cable assembly
W3	65/6642-65/6645	5080-2206	Secondary power cable
W3	65/6641A	06641-80002	Secondary power cable
W7		5080-2213	Bias cable
W8		5080-2209	GPIB power cable assembly
W9		06652-80010	6-Conductor phone cable
W10		06652-80011	6-Conductor phone cable
W19		5080-2261	Cable assembly LCD display
		5001-0538	Side Trim
		5001-6765	Front panel
		500 1-6769	Cover
		5001-6775	Plate cover, Ref. 654xA rear panel
		5040-1665	Keypad
		5063-3407	PCA Keypad
		5040-1687	Front frame
		5040-1700	Molded collar, Ref. RPG
		5041-8819	Strap-Cap handle, front
		5041-8820	Strap-Cap handle, rear
		5061-1190	LCD display
		5062-3703	HDL strap assembly
P640		1252-3698	Connector
F450		2110-0010	Fuse 5AM 250V for 120 V operation
		2110-0565	Fuse holder (Ref F450)
F450		2110-0056	Fuse 6AM 250V for 100 V operation
F450		2110-0003	Fuse 3AM 250V for 220 V operation
	664xA, 665xA	5959-3350	Operating Manual
	654xA, 655xA	5959-3374	Operating Manual

Table 5-5. Parts List For 200 Watt A1 Main Board for Keysight Models 654xA and 664xA

Reference Desig.	Applicable Models	Keysight Part No.	Description
C202-C204		0160-4801	Capacitor 100PF 5%
C205		0160-4835	Capacitor .1UF 10% 50V
C206	65/6641A	0160-4835	Capacitor .1UF 10% 50V
C207	65/6641A	0160-4801	Capacitor 100PF 5%
C208, C209	65/6641A	0160-6806	Capacitor .1UF 400V
C211	65/6641A	0160-4812	Capacitor 220PF 5%
C301-C304	65/6641A	0160-4801	Capacitor 100PF 5%
C305, C36	65/6641A	0160-4835	Capacitor .1UF 10% 50V
C307	65/6641A	0160-4801	Capacitor 100PF 5%
C309	65/6641A	0160-6806	Capacitor .1UF 400V
C405	65/6641A	0180-4461	Capacitor 27000UF 35V
	65/6642A	0180-4462	Capacitor 12000UF 63V
	65/6643A,	0180-4465	Capacitor 4700UF 100V
	65/6644A	0180-4463	Capacitor 2700UF 150V
	65/6645A	0180-4464	Capacitor 1200UF 250V
C406	65/6641A	0180-4461	Capacitor 27000UF 35V
	65/6642A	0180-4462	Capacitor 12000UF 63V
	65/6643A	0180-4465	Capacitor 4700UF 100V
C407	65/6641A	0180-4461	Capacitor 27000UF 35V
C408	65/6641A	0180-4461	Capacitor 27000UF 35V
C413		0160-5469	Capacitor IUF 10% 50V
C414, C415		0160-5422	Capacitor .047UF 20%
C416		0180-3963	Capacitor 17000UF 16V
C418	65/6641A, 65/6642A	0160-5422	Capacitor .047UF 20%
	65/6643A, 65/6644A	0160-0168	Capacitor .1UF 10%
	65/6645A	0160-6806	Capacitor .1UF 10%
C450		0160-4183	Capacitor 1000PF 20%
C451	65/6641A	0160-4183	Capacitor 1000PF 20%
C452		0160-4413	Capacitor .6UF 10%
C501		0160-5422	Capacitor .047UF 20%
C502		0160-4805	Capacitor 47PF 5% 100V
C503		0160-4805	Capacitor 47PF 5% 100V
C504		0160-5422	Capacitor .047UF 20%
C505		0180-4129	Capacitor IUF 35V
C506		0160-4801	Capacitor 100PF 5%
C507		0160-5422	Capacitor .047UF 20%
C509		0160-5422	Capacitor .047UF 20%
C510		0160-4801	Capacitor 100PF 5%
C512		0160-5422	Capacitor .047UF 20%
C513		0160-4801	Capacitor 100PF 5%
C515		0160-5422	Capacitor .047UF 20%
C516		0160-4801	Capacitor 100PF 5%
C517		0160-5422	Capacitor .047UF 20%
C518		0160-5422	Capacitor .047UF 20%
C519		0180-4129	Capacitor IUF 35V
C520		0160-5098	Capacitor.22UF 10%
C521		0160-5098	Capacitor.22UF 10%
C522		0160-5098	Capacitor.22UF 10%

Table 5-5. Parts List For 200 Watt A1 Main Board for Keysight Models 654xA and 664xA(continued)

Reference Desig.	Applicable Models	Keysight Part No.	Description
C524	65/6641A	0160-5422	Capacitor .047UF 20%
C600		0160-5422	Capacitor .047UF 20%
C602		0180-3298	Capacitor 2200UF 50V
C603		0180-3298	Capacitor 2200UF 50V
C604		0180-4129	Capacitor IUF 35V
C605		0180-0197	Capacitor 2.2UF 20V TA
C606		0180-4129	Capacitor IUF 35V
C610		0160-5469	Capacitor IUF 10% 50V
C611		0160-4808	Capacitor 470PF 5%
C612		0160-4835	Capacitor .IUF 10% 50V
C613	65/6641A	0160-4835	Capacitor .IUF 10% 50V
C613	65/6642A	0160-4834	Capacitor .047UF 10%
C613	65/6643A	0160-5166	Capacitor .015UF 20%
C613	65/6644A, 65/6645A	0160-5409	Capacitor 3000PF 5%
C614	65/6641A	0160-4835	Capacitor .IUF 10% 50V
C614	65/6642A	0160-4834	Capacitor .047UF 10%
C614	65/6643A	0160-5166	Capacitor .015UF 20%
C614	65/6644A, 65/6645A	0160-5409	Capacitor 3000PF 5%
C615		0160-5422	Capacitor .047UF 20%
C616	65/6641A	0160-5422	Capacitor .047UF 20%
C617	65/6641A	0160-5422	Capacitor .047UF 20%
C618	65/6641A	0160-5422	Capacitor .047UF 20%
C619	65/6641A, 65/6643A	0160-4791	Capacitor 10PF 5% 100V
C619	65/6642A	0160-4795	Capacitor 4.7PF
C619	65/6644A, 65/6645A	0160-4789	Capacitor 15PF 5% 100V
C621		0160-482	Capacitor 1200PF 5%
C622	65/6641A, 65/6643A	0160-4791	Capacitor 10PF 5% 100V
C622	65/6642A	0160-4795	Capacitor 4.7PF
C622	65/6644A, 65/6645A	0160-4789	Capacitor 15PF 5% 100V
C623	65/6641A, 65/6642A	0160-4801	Capacitor 100PF 5%
C624		0160-4788	Capacitor 18PF 5% 100V
C640	65/6641A	0160-6827	Capacitor .022UF 400V
C641	65/6641A	0160-0161	Capacitor .0IUF 10%
C642	65/6641A, 65/6642A	0160-4803	Capacitor 68PF 5% 100V
C642	65/6643A-65/6645A	0160-4801	Capacitor 100PF 5%
C643		0160-5422	Capacitor .047UF 20%
C644		0160-5422	Capacitor .047UF 20%
C645		0160-4355	Capacitor .0IUF 10%
C646	65/6641A, 65/6642A	0160-4805	Capacitor 47PF 5% 100V
C646	65/6643A-65/6645A	0160-4814	Capacitor 150PF 5%
C647	65/6643A-65/6645A	0160-4811	Capacitor 270PF 5%
C648	65/6643A-65/6645A	0160-4811	Capacitor 270PF 5%
C671		0160-4791	Capacitor 10PF 5% 100V
C672		0160-4807	Capacitor 33PF 5% 100V
C691	65/6641A-65/6643A	0160-5422	Capacitor .047UF 20%
C691	65/6644A	0160-4834	Capacitor .047UF 10%
C691	65/6645A	0160-0159	Capacitor 6800PF 10%
C692		0160-4355	Capacitor .0IUF 10%
C693	65/6641A	0160-4355	Capacitor .0IUF 10%

Table 5-5. Parts List For 200 Watt A1 Main Board for Keysight Models 654xA and 664xA(continued)

Reference Desig.	Applicable Models	Keysight Part No.	Description
C694	65/6641A	0160-5410	Capacitor 3300PF 5%
C695	65/6641A	0180-4469	Capacitor 4700UF 20V
C695	65/6642A	0180-2724	Capacitor 550UF 40V AL
C695	65/6643A	0180-4438	Capacitor 180UF 63V
C695	65/6644A	0180-4439	Capacitor 68UF 100V
C695	65/6645A	0180-4471	Capacitor 33UF 200V
C700		0160-5422	Capacitor .047UF 20%
C701		0160-5422	Capacitor .047UF 20%
C702		0160-4812	Capacitor 220PF 5%
C703		0160-5422	Capacitor .047UF 20%
C704		0160-5422	Capacitor .047UF 20%
C705		0160-5422	Capacitor .047UF 20%
C706		0160-4832	Capacitor .01UF 10%
C707		0160-5422	Capacitor .047UF 20%
C708		0160-4832	Capacitor .01UF 10%
C720		0180-4136	Capacitor 10UF 20V
C741		0160-4801	Capacitor 100PF 5%
C742		0180-0197	Capacitor 2.2UF 20V TA
C743		0160-4801	Capacitor 100PF 5%
C770		0180-4136	Capacitor 10UF 20V
C771		0160-4830	Capacitor 2200PF 10%
C772		0180-4132	Capacitor 6.8UF 35V
CR700	65/6641A	1884-0349	SCR
CR701	65/6642A-65/6644A	1884-0340	SCR (P/O 5060-3376)
CR701	65/6645A	1884-0340	SCR (P/O 06645-60002)
D201		1901-1098	Diode 1N4150
D401	65/6641A	1901-1152	Power Diode
D401	65/6642A-65/6644A	5060-3378	Diode Assembly
D401	65/6645A	1901-1087	Diode Power Rectifier
D402	65/6641A	1901-1152	Power Diode assy.
D402	65/6642A-65/6644A	5060-3378	Diode Assembly
D402	65/6645A	1901-1087	Diode Power Rectifier
D403	65/6641A	1901-1152	Power Diode assy.
D403	65/6642A-65/6644A	5060-3378	Diode Assembly
D403	65/6645A	1901-1087	Diode Power Rectifier
D404	65/6641A	1901-1152	Power Diode assy.
D404	65/6642A-65/6644A	5060-3378	Diode Assembly
D404	65/6645A	1901-1087	Diode Power Rectifier
D405	65/6641A	5060-3228	Regulator Assembly HS
D406	65/6642A-65/6645A	1901-1087	Diode Power Rectifier
D407	65/6642A	1901-1087	Diode Power Rectifier
D408	65/6641A	5060-3228	Regulator Assembly HS
D409		1901-1087	Diode Power Rectifier
D600		1901-0731	Diode Power Rectifier
D601		1901-0731	Diode Power Rectifier
D602		1901-0731	Diode Power Rectifier
D603		1901-0731	Diode Power Rectifier

Table 5-5. Parts List For 200 Watt A1 Main Board for Keysight Models 654xA and 664xA(continued)

Reference Desig.	Applicable Models	Keysight Part No.	Description
D604		1901-1098	Diode 1N4150
D605		1901-1098	Diode 1N4150
D606		1901-1098	Diode 1N4150
D610		1901-0880	Diode General Purpose
D611		1901-0880	Diode General Purpose
D612		1901-0880	Diode General Purpose
D613		1901-0880	Diode General Purpose
D614		1901-0880	Diode General Purpose
D615		1901-1098	Diode 1N4150
D616		1901-1098	Diode 1N4150
D617		1901-1098	Diode 1N4150
D618		1901-1098	Diode 1N4150
D619		1901-1098	Diode 1N4150
D640		1901-0880	Diode General Purpose
D641		1901-0880	Diode General Purpose
D643		1901-0880	Diode General Purpose
D644		1901-0880	Diode General Purpose
D645		1901-0880	Diode General Purpose
D646		1901-0880	Diode General Purpose
D647		1901-0880	Diode General Purpose
D648	65/6641A	1901-0880	Diode General Purpose
D649	65/6641A	1901-0880	Diode General Purpose
D650	65/6641A	1901-0880	Diode General Purpose
D651	65/6641A	1901-1098	Diode 1N4150
D670	65/6641A	1901-1098	Diode 1N4150
D671	65/6641A	1901-1098	Diode 1N4150
D672	65/6641A	1901-1098	Diode 1N4150
D673	65/6641A	1901-1098	Diode 1N4150
D676	65/6645A	1901-0731	Diode Power Rectifier
D690	65/6641A	1901-1127	Rectifier
D691	65/6642A-65/6644A	1901-1383	Rectifier (P/O 5060-3376)
D692	65/6645A	1901-1130	Rectifier (P/O 06645-60002)
F205		8159-0005	Resistor Zero Ohms
F206		8159-0005	Resistor Zero Ohms
F207		8159-0005	Resistor Zero Ohms
F229		8159-0005	Resistor Zero Ohms
F230		8159-0005	Resistor Zero Ohms
F232		8159-0005	Resistor Zero Ohms
F304		8159-0005	Resistor Zero Ohms
F305		8159-0005	Resistor Zero Ohms
F306		8159-0005	Resistor Zero Ohms
F307		8159-0005	Resistor Zero Ohms
F329		8159-0005	Resistor Zero Ohms
F330		8159-0005	Resistor Zero Ohms
F331	65/6645A	8159-0005	Resistor Zero Ohms
F332	65/6645A	8159-0005	Resistor Zero Ohms

Table 5-5. Parts List For 200 Watt A1 Main Board for Keysight Models 654xA and 664xA (continued)

Reference Desig.	Applicable Models	Keysight Part No.	Description
F402		2110-0697	Fuse, subminiature 15AM, 32V
F403		2110-0697	Fuse, subminiature 15AM, 32V
F415	65/6641A-65/6644A	8159-0005	Resistor Zero Ohms
F417	65/6641A-65/6642A	8159-0005	Resistor Zero Ohms
F451	65/6641A-65/6644A	8159-0005	Resistor Zero Ohms
F452	65/6641A-65/6644A	8159-0005	Resistor Zero Ohms
F600		2110-0699	Fuse, subminiature 5A, 125V
F601		2110-0699	Fuse, subminiature 5A, 125V
F605	65/6642A	8159-0005	Resistor Zero Ohms
F606	65/6642A	8159-0005	Resistor Zero Ohms
F607	65/6642A	8159-0005	Resistor Zero Ohms
F670	65/6642A	8159-0005	Resistor Zero Ohms
F675		2110-0671	Fuse .125AM, 125V
F700		2110-0671	Fuse .125AM, 125V
F701		2110-0671	Fuse .125AM, 125V
F902	65/6642A	8159-0005	Resistor Zero Ohms
J300		1251-4245	Connector 2-PIN M
J401		1251-5339	Connector-UTIL
J450		1251-3837	Connector 4-PIN M
J451		1252-3771	AC LINE MODULE
J452		1252-2105	Connector-UTIL
J501		1251-8184	MOD PHONE RCPT
J600		1251-4246	Connector-POST-TP-HDR
J602		1252-0063	Connector-POST-TP-HDR
J640		1252-3693	Connector
J690		0360-1809	Barrier block
Q201	65/6641A-65/6644A	1854-0989	XSTR NPN SI
Q201	65/6645A	1855-0849	MOSFET-N-CHAN
Q202	65J6641A, 65/6642A	5060-3315	FET Assembly HS (1855-0725)
Q202	65/6643A, 65/6644A	5060-3314	FET Assembly HS (1855-0641)
Q203	65/6641A-65/6644A	1854-0989	XSTR NPN SI
Q203	65/6645A	1855-0849	MOSFET-N-CHAN
Q204	65/6641A, 65/6642A	5060-3315	FET Assembly HS (1855-0725)
Q204	65/6643A, 65/6644A	5060-3314	FET Assembly HS (1855-0641)
Q205	65/6641A-65/6644A	1854-0989	XSTR NPN SI
Q205	65/6645A	1854-1162	XSTR-NPN
Q206	65/6641A, 65/6642A	5060-3231	Regulator Assembly HS (1853-0497)
Q206	65/6643A-65/6645A	5060-3250	ASSY-HS REG (1853-0642)
Q207	65/6641A-65/6644A	1854-0989	XSTR NPN SI
Q207	65/6645A	1855-0849	MOSFET-N-CHAN
Q208	65/6641A, 65/6642A	5060-3315	FET Assembly HS (1855-0725)
Q208	65/6643A, 65/6644A	5060-3314	FET Assembly HS (1855-0641)
Q301	65/6641A-65/6644A	1854-0989	XSTR NPN SI
Q301	65/6645A	1855-0849	MOSFET-N-CHAN
Q302	65/6641A, 65/6642A	5060-3315	FET Assembly HS (1855-0725)
Q302	65/6643A, 65/6644A	5060-3314	FET Assembly HS (1855-0641)

Table 5-5. Parts List For 200 Watt A1 Main Board for Keysight Models 654xA and 664xA (continued)

Reference Desig.	Applicable Models	Keysight Part No.	Description
Q303	65/6641A-65/6644A	1854-0989	XSTR NPN SI
Q303	65/6645A	1855-0849	MOSFET-N-CHAN
Q304	65/6641A, 65/6642A	5060-3315	FET Assembly HS (1855-0725)
Q304	65/6643A, 65/6644A	5060-3314	FET Assembly HS (1855-0614)
Q305	65/6641A-65/6644A	1854-0989	XSTR NPN SI
Q305	65/6645A	1855-0849	MOSFET-N-CHAN
Q306	65/6641A, 65/6642A	5060-3315	FET Assembly HS (1855-0725)
Q306	65/6643A, 65/6644A	5060-3314	FET Assembly HS (1855-0614)
Q307	65/6641A-65/6644A	1854-0989	XSTR NPN SI
Q307	65/6645A	1855-0849	MOSFET-N-CHAN
Q308	65/6641A, 65/6642A	5060-3315	FET Assembly HS (1855-0725)
Q308	65/6643A, 65/6644A	5060-3314	FET Assembly HS (1855-0614)
Q600	65/6642A	5060-3321	Regulator Assembly HS (1826-0106)
Q601	65/6642A	5060-3320	Regulator Assembly HS (1826-0122)
Q700		1854-0477	XSTR NPN 2N2222A
Q770		5060-3245	Regulator Assembly HS
R201	65/6641A, 65/6642A	0811-3849	Resistor 0.25 5% 3W
R201	65/6643A	0811-3848	Resistor 0.39 5% 3W
R201	65/6644A	0811-3847	Resistor 0.66 1% 3W
R201	65/6645A	0811-1220	Resistor 1.5 5% 3W PW
R202		0698-3430	Resistor 21.5 1%
R203	65/6641A-65/6644A	0698-3441	Resistor 215 1% .125W
R204		0757-0280	Resistor 1K 1% .125W
R206	65/6641A, 65/6642A	0811-3849	Resistor 0.25 5% 3W
R206	65/6643A	0811-3848	Resistor 0.39 5% 3W
R206	65/6644A	0811-3847	Resistor 0.66 1% 3W
R206	65/6645A	0811-1220	Resistor 1.5 5% 3W PW
R207		0698-3430	Resistor 21.5 1%
R208	65/6641A-65/6644A	0698-3441	Resistor 215 1% .125W
R209		0757-0280	Resistor 1K 1% .125W
R210	65/6641A	0698-8959	Resistor 619K 1%
R210	65/6642A	0698-8959	Resistor 619K 1%
R210	65/6643A	0757-0481	Resistor 475K 1%
R210	65/6644A	0757-0481	Resistor 475K 1%
R210	65/6644A	0699-0070	Resistor 3.16M 1%
R211	65/6641A,65/6642A	0811-3849	Resistor 0.25 5% 3W
R211	65/6643A	0811-3848	Resistor 0.39 5% 3W
R211	65/6644A	0811-3847	Resistor 0.66 1% 3W
R211	65/6645A	0811-1220	Resistor 1.5 5% 3W PW
R212		0757-0316	Resistor 42.2 1%
R213		0698-3441	Resistor 215 1% .125W
R214		0698-0085	Resistor 2.61K 1%
R215	65/6641A-65/6643	0698-3454	Resistor 215K 1%
R215	65/6644A, 65/6645A	0757-0466	Resistor 110K 1%

Table 5-5. Parts List For 200 Watt A1 Main Board for Keysight Models 654xA and 664xA (continued)

Reference Desig.	Applicable Models	Keysight Part No.	Description
R216	65/6641A, 65/6642A	0811-3849	Resistor 0.25 5% 3W
R216	65/6643A	0811-3848	Resistor 0.39 5% 3W
R216	65/6644A	0811-3847	Resistor 0.66 1% 3W
R216	65/6645A	0811-1220	Resistor 1.5 5% 3W PW
R217		0698-3430	Resistor 21.5 1%
R218	65/6641A-65/6644A	0698-3441	Resistor 215 1% 0.125W
R219		0757-0280	Resistor 1K 1% .125W
R220	65/6641A-65/6644A	0698-3454	Resistor 215K 1%
R220	65/6645A	0698-8827	Resistor 1M 1% .125W
R221		0757-0280	Resistor 1K 1% .125W
R223		0683-0475	Resistor 4.7 5% .25W
R224		0683-0475	Resistor 4.7 5% .25W
R225	65/6641A	0811-3849	Resistor 0.25 5% 3W
R226	65/6641A	0811-3849	Resistor 0.25 5% 3W
R227	65/6641A	0811-3849	Resistor 0.25 5% 3W
R228	65/6641A	0811-3849	Resistor 0.25 5% 3W
R301	65/6641A, 65/6642A	0811-3849	Resistor 0.25 5% 3W
R301	65/6643A	0811-3848	Resistor 0.39 5% 3W
R301	65/6644A	0811-3847	Resistor 0.66 1% 3W
R301	65/6645A	0811-1220	Resistor 1.5 5% 3W PW
R302		0698-3430	Resistor 21.5 1%
R303	65/6641A-65/6644A	0698-3441	Resistor 215 1% .125W
R304		0757-0280	Resistor 1K 1% .125W
R305	65/6644A	0698-3459	Resistor 383K 1%
R305	65/6645A	0698-3454	Resistor 215K 1%
R306	65/6641A, 65/6642A	0811-3849	Resistor 0.25 5% 3W
R306	65/6643A	0811-3848	Resistor 0.39 5% 3W
R306	65/6644A	0811-3847	Resistor 0.66 1% 3W
R306	65/6645A	0811-1220	Resistor 1.5 5% 3W PW
R307		0698-3430	Resistor 21.5 1%
R308	65/6641A-65/6644A	0698-3441	Resistor 215 1% .125W
R309		0757-0280	Resistor 1K 1% .125W
R310	65/6641A-65/6643A	0698-3454	Resistor 215K 1%
R310	65/6644A	0757-0470	Resistor 162K 1%
R310	65/6645A	0757-0469	Resistor 150K 1%
R311	65/6641A, 65/6642A	0811-3849	Resistor 0.25 5% 3W
R311	65/6643A	0811-3848	Resistor 0.39 5% 3W
R311	65/6644A	0811-3847	Resistor 0.66 1% 3W
R311	65/6645A	0811-1220	Resistor 1.5 5% 3W PW
R312		0698-3430	Resistor 21.5 1%
R313	65/6641A-65/6644A	0698-3441	Resistor 215 1% .125W
R314		0757-0280	Resistor 1K 1% .125W
R315		0757-0465	Resistor 100K 1%
R316	65/6641A, 65/6642A	0811-3849	Resistor 0.25 5% 3W
R316	65/6643A	0811-3848	Resistor 0.39 5% 3W
R316	65/6644A	0811-3847	Resistor 0.66 1% 3W
R316	65/6645A	0811-1220	Resistor 1.5 5% 3W PW

Table 5-5. Parts List For 200 Watt A1 Main Board for Keysight Models 654xA and 664xA (continued)

Reference Desig.	Applicable Models	Keysight Part No.	Description
R317		0698-3430	Resistor 21.5 1%
R318	65/6641A-65/6644A	0698-3441	Resistor 215 1% .125W
R319		0757-0280	Resistor 1K 1% .125W
R320	65/6641A, 65/6642A	0757-0463	Resistor 82.5K 1%
R320	65/6644A	0757-0463	Resistor 82.5K 1%
R320	65/6643A	0757-0465	Resistor 100K 1%
R320	65/6645A	0757-0467	Resistor 121K 1%
R323		0683-0475	Resistor 4.7 5% .25W
R325	65/6641A	0811-3849	Resistor 0.25 5% 3W
R326	65/6641A	0811-3849	Resistor 0.25 5% 3W
R327	65/6641A	0811-3849	Resistor 0.25 5% 3W
R328	65/6641A	0811-3849	Resistor 0.25 5% 3W
R410	65/6641A	0813-0050	Resistor 100 5% 3W PW
R410	65/6642A	0811-1799	Resistor 390 5% 3W PW
R411	65/6643A	0811-0944	Resistor 800 5% 10W
R411	65/6644A	0811-1913	Resistor 1.5K 5% 10W
R411	65/6645A	0811-1914	Resistor 5K 5% 10W PW
R412	65/6641A	0813-0050	Resistor 100 5% 3W PW
R412	65/6642A	0811-1799	Resistor 390 5% 3W PW
R412	65/6643A-65/6645A	0811-1799	Resistor 390 5% 3W PW
R413		0757-0280	Resistor 1K 1% .125W
R414	65/6645A	0811-1914	Resistor 5K 5% 10W PW
R415	65/6645A	8159-0005	Resistor Zero Ohms
R416	65/6641A	0757-0395	Resistor 56.2 1%
R416	65/6642A	0757-0403	Resistor 121 1% .125W
R416	65/6643A	0757-0404	Resistor 130 1% .125W
R416	65/6644A	0698-3486	Resistor 232 1% .125W
R416	65/6645A	0757-0413	Resistor 392 1% .125W
R450		0698-8827	Resistor 1M 1% .125W
R451	65/6645A	8159-0005	Resistor Zero Ohms
R452	65/6645A	8159-0005	Resistor Zero Ohms
R501		0698-3456	Resistor 287K 1%
R502		1810-0305	Network-Resistor SIP
R504		0757-0458	Resistor 51.1K 1%
R505		0757-0428	Resistor 1.62K 1%
R506		0699-1212	Resistor 19K .1%
R507		0698-6392	Resistor 22K .1% .125W
R508		0757-0442	Resistor 10K 1% .125W
R509		0757-0401	Resistor 100 1% .125W
R510		0757-0401	Resistor 100 1% .125W
R511		0757-0401	Resistor 100 1% .125W
R512		0698-3456	Resistor 287K 1%
R513		0757-0465	Resistor 100K 1%
R514		0757-0465	Resistor 100K 1%
R515		0757-0462	Resistor 75K 1% .125W
R516		0698-0084	Resistor 2.15K 1%
R517		0698-0084	Resistor 2.15K 1%

Table 5-5. Parts List For 200 Watt A1 Main Board for Keysight Models 654xA and 664xA (continued)

Reference Desig.	Applicable Models	Keysight Part No.	Description
R518		0698-0084	Resistor 2.15K 1%
R520		0698-3155	Resistor 4.64K 1%
R501	65/6645A	8159-0005	Resistor Zero Ohms
R505	65/6641A	8159-0005	Resistor Zero Ohms
R505	65/6643A-65/6645A	8159-0005	Resistor Zero Ohms
R506	65/6641A-65/6645A	8159-0005	Resistor Zero Ohms
R507	65/6641A-65/6645A	8159-0005	Resistor Zero Ohms
R510		0698-6360	Resistor 10K .1%
R511		0698-6343	Resistor 9K .1% .125W
R512		0757-0442	Resistor 10K 1% .125W
R513		0698-6630	Resistor 20K .1%
R514		0698-3156	Resistor 14.7K 1%
R515		0698-3156	Resistor 14.7K 1%
R516		0683-2255	Resistor 2.2M 5% .25W
R517		0757-0279	Resistor 3.16K 1%
R518		0757-0441	Resistor 8.25K 1%
R519		0698-0082	Resistor 464 1% .125W
R520		0757-0449	Resistor 20K 1% .125W
R521		0757-0449	Resistor 20K 1% .125W
R522		0699-2246	Resistor 25K .05%
R523	65/6641A	0699-3103	Resistor 19K .05%
R523	65/6642A	0699-2248	Resistor 47.5K .05%
R523	65/6643A	0699-2879	Resistor 80K .05% 5PPM .1W
R523	65/6644A	0699-2198	Resistor 243K .05%
R523	65/6645A	0699-3104	Resistor 250K .125W
R524	65/6641A	0698-6362	Resistor 1K .1% .125W
R524	65/6642A	0698-6631	Resistor 2.5K .1%
R524	65/6643A	0698-6614	Resistor 7.5K .1%
R524	65/6644A	0698-3988	Resistor 42K .1%
R524	65/6645A	0698-6353	Resistor 50K .1%
R525		0699-2246	Resistor 25K .05%
R526	65/6641A	0699-3103	Resistor 19K .05%
R526	65/6642A	0699-2248	Resistor 47.5K .05%
R526	65/6643A	0699-2879	Resistor 80K .05% 5PPM .1W
R526	65/6644A	0699-2198	Resistor 243K .05%
R526	65/6645A	0699-3104	Resistor 250K .125W
R527	65/6641A	0698-6362	Resistor 1K .1%.125W
R527	65/6642A	0698-6631	Resistor 2.5K .1%
R527	65/6643A	0698-6614	Resistor 7.5K .1%
R527	65/6644A	0698-3988	Resistor 42K .1%
R527	65/6645A	0698-6353	Resistor 50K .1%
R528		0698-6320	Resistor 5K .1% .125W
R529		0757-0481	Resistor 475K 1%
R530		0698-4470	Resistor 6.98K 1%
R531		0698-4014	Resistor 787 1% .125W
R532		0698-3156	Resistor 14.7K 1%
R533		0698-3162	Resistor 46.4K 1%

Table 5-5. Parts List For 200 Watt A1 Main Board for Keysight Models 654xA and 664xA (continued)

Reference Desig.	Applicable Models	Keysight Part No.	Description
R535		0698-6320	Resistor 5K .1% .125W
R537	65/6641A, 65/6642A	0757-0442	Resistor 10K 1% .125W
R537	65/6643A, 65/6644A	0698-3155	Resistor 4.64K 1%
R537	65/6645A	0757-0442	Resistor 10K 1% .125W
R539		0698-3456	Resistor 287K 1%
R540		0698-6343	Resistor 9K .1% .125W
R541		0698-8061	Resistor 8.25K .1%
R542		0757-0442	Resistor 10K 1% .125W
R543		0698-6630	Resistor 20K .1%
R544		0698-3156	Resistor 14.7K 1%
R545		0757-0280	Resistor 1K 1% .125W
R546		0698-6977	Resistor 30K .1% .125
R547		0698-8671	Resistor 273.2 1% .1
R548	65/6641A, 65/6642A	0698-8671	Resistor 273.2 1% .1
R548	65/6643A	0699-021	Resistor 859 .1%
R548	65/6644A	0698-5347	Resistor 495.5 .1%
R548	65/6645A	0699-1982	Resistor 1.055K.1%
R549		0698-6320	Resistor 5K .1% .125W
R550		0698-6320	Resistor 5K .1% .125W
R551		0698-6630	Resistor 20K .1%
R552		0698-6630	Resistor 20K .1%
R553		0698-6320	Resistor 5K .1% .125W
R554		0698-0084	Resistor 2.15K 1%
R555		0698-6320	Resistor 5K .1% .125W
R556		0698-3156	Resistor 14.7K 1%
R557	65/6641A	5080-2217	Shunt .005 Ohms
R557	65/6642A	5080-2218	Shunt .01 Ohms
R557	65/6643A, 65/6644A	0811-3770	Resistor .05 Ohm 1%
R557	65/6645A	0811-3771	Resistor .25 Ohm 1%
R558		0757-0458	Resistor 51.1K 1%
R559	65/6641A, 65/6642A	0698-3432	Resistor 26.1 1%
R559	65/6643A	0757-0316	Resistor 42.2 1%
R559	65/6644A	0698-3433	Resistor 28.7 1%
R559	65/6645A	0757-0397	Resistor 68.1 1%
R560		0698-6977	Resistor 30K .1% .125
R562	65/6641A, 65/6642A	0698-3432	Resistor 26.1 1%
R562	65/6643A	0757-0316	Resistor 42.2 1%
R562	65/6644A	0698-3433	Resistor 28.7 1%
R562	65/6645A	0757-0280	Resistor 1K 1% .125W
R580	65/6641A	0698-0084	Resistor 2.15K 1%
R580	65/6642A	0757-0283	Resistor 2K 1% .125W
R580	65/6643A, 65/6644A	0757-0280	Resistor 1K 1% .125W
R580	65/6645A	0757-0279	Resistor 3.16K 1%
R581	65/6641A	0698-3162	Resistor 46.4K 1%
R581	65/6642A	0757-0459	Resistor 56.2K 1%
R581	65/6643A, 65/6644A	0698-3160	Resistor 31.6K 1%
R581	65/6645A	0757-0459	Resistor 56.2K 1%

Table 5-5. Parts List For 200 Watt A1 Main Board for Keysight Models 654xA and 664xA (continued)

Reference Desig.	Applicable Models	Keysight Part No.	Description
R583		0698-3160	Resistor 31.6K 1%
R584		0757-0442	Resistor 10K 1% .125W
R585		0757-0419	Resistor 681 1% .125W
R590		0757-0416	Resistor 511 1% .125W
R591	65/6641A, 65/6642A	0757-0280	Resistor 1K 1% .125W
R591	65/6643A	0757-0274	Resistor 1.21K 1%
R591	65/6644A	0698-3153	Resistor 3.83K 1%
R591	65/6645A	0698-3156	Resistor 14.7K 1%
R592	65/6641A, 65/6642A	0757-0280	Resistor 1K 1% .125W
R592	65/6643A	0757-0274	Resistor 1.21K 1%
R592	65/6644A	0698-3153	Resistor 3.83K 1%
R592	65/6645A	0698-3156	Resistor 14.7K 1%
R595	65/6641A	0812-0083	Resistor 40 5% 5W PW
R595	65/6642A	0811-1204	Resistor 200 5% 5W PW
R595	65/6643A	0811-1860	Resistor 600 5% 5W PW
R595	65/6644A	0812-0100	Resistor 2K 5% 5W PW
R595	6645A	0811-1708	Resistor 7K 5% 5W 5W PW
R596		0683-1065	Resistor 10M 5% .25W
R597		0683-1065	Resistor 10M 5% .25W
R601	65/6645A	8159-0005	Resistor Zero Ohms
R605	65/6641A, 65/6643A-65/6645A	8159-0005	Resistor Zero Ohms
R606	65/6641A, 65/6643A-65/6645A	8159-0005	Resistor Zero Ohms
R607		8159-0005	Resistor Zero Ohms
R610		0698-6360	Resistor 10K.1%
R611		0698-6343	Resistor 9K .1% .125W
R612		0757-0442	Resistor 10K 1% .125W
R613		0698-6630	Resistor 20K .1%
R614		0698-3156	Resistor 14.7K 1%
R615		0698-3156	Resistor 14.7K 1%
R616		0683-2255	Resistor 2.2M 5% .25W
R617		0757-0279	Resistor 3.16K 1%
R618		0757-0441	Resistor 8.25K 1%
R619		0698-0082	Resistor 464 1% .125W
R620		0757-0449	Resistor 20K 1% .125W
R621		0757-0449	Resistor 20K 1% .125W
R622	All except 6644A	0699-2246	Resistor 25K .05%
R622	6644A	0699-2248	Resistor 47.5K .05%
R623	6543A	0699-2879	Resistor 80K .05% 5PPM .1W
R623	6544A	0699-2198	Resistor 243K .05%
R623	6641A	0699-3103	Resistor 19K .05%
R623	6642A	0699-2248	Resistor 47.5K .05%
R623	6645A	0699-3104	Resistor 250K .125W
R624	6543A	0698-6614	Resistor 7.5K .1%
R624	6544A	0698-3988	Resistor 42K .1%
R624	6641A	0698-6362	Resistor 1K .1% .125W
R624	6642A	0698-6631	Resistor 2.5K .1%

Table 5-5. Parts List For 200 Watt A1 Main Board for Keysight Models 654xA and 664xA (continued)

Reference Desig.	Applicable Models	Keysight Part No.	Description
R624	6645A	0698-6353	Resistor 50K .1%
R625	All except 6644A	0699-2246	Resistor 25K .05%
R625	6644A	0699-2248	Resistor 47.5K .05%
R626	6543A	0699-2879	Resistor 80K .05% 5PPM .1W
R626	6544A	0699-2198	Resistor 243K .05%
R626	6641A	0699-3103	Resistor 19K .05%
R626	6642A	0699-2248	Resistor 47.5K .05%
R626	6645A	0699-3104	Resistor 250K .125W
R627	6543A	0698-6614	Resistor 7.5K .1%
R627	6544A	0698-3988	Resistor 42K .1%
R627	6641A	0698-6362	Resistor 1K .1% .125W
R627	6642A	0698-6631	Resistor 2.5K .1%
R627	6645A	0698-6353	Resistor 50K .1%
R628	65/6641A-65/6645A	0698-6320	Resistor 5K .1% .125W
R629		0757-0481	Resistor 475K 1%
R630		0698-4470	Resistor 6.98K 1%
R631		0698-4014	Resistor 787 1% .125W
R632		0698-3156	Resistor 14.7K 1%
R633		0698-3162	Resistor 46.4K 1%
R635		0698-6320	Resistor 5K .1% .125W
R637	65/6643A, 65/6644A	0698-3155	Resistor 4.64K 1%
R637	65/6641A, 65/6642A, 65/6645A	0757-0442	Resistor 10K 1% .125W
R639		0698-3456	Resistor 287K 1%
R640		0698-6343	Resistor 9K .1% .125W
R641		0698-8061	Resistor 8.25K .1%
R642		0757-0442	Resistor 10K 1% .125W
R643		0698-6630	Resistor 20K .1%
R644		0698-3156	Resistor 14.7K 1%
R645		0757-0280	Resistor 1K 1% .125W
R646		0698-6977	Resistor 30K .1% .125
R647	65/6643A	0699-0211	Resistor 859 .1%
R647	65/6644A	0698-5347	Resistor 495.5 .1%
R647	65/6641A, 65/6642A	0698-8671	Resistor 273.2 1% .1
R647	65/6645A	0699-1982	Resistor 1.055K .1%
R648	65/6643A	0699-0211	Resistor 859 .1%
R648	6516644A	0698-5347	Resistor 495.5 .1%
R649		0698-6320	Resistor 5K .1% .125W
R650		0698-6320	Resistor 5K .1% .125W
R651		0698-6630	Resistor 20K .1%
R652		0698-6630	Resistor 20K .1%
R653		0698-6320	Resistor 5K .1% .125W
R654		0698-0084	Resistor 2.15K 1%
R655		0698-6320	Resistor 5K .1% .125W
R656		0698-3156	Resistor 14.7K 1%
R657	65/6643A, 65/6644A	0811-3770	Resistor .05 Ohm 1%
R657	65/6641A	5080-2217	Resistor SHUNT .005 Ohms
R657	65/6642A	5080-2218	SHUNT .01 Ohms

Table 5-5. Parts List For 200 Watt A1 Main Board for Keysight Models 654xA and 664xA (continued)

Reference Desig.	Applicable Models	Keysight Part No.	Description
R657	65/ 6645A	0811-3771	Resistor .25 Ohm 1%
R658		0757-0458	Resistor 51.1K 1%
R659	65/6643A	0757-0316	Resistor 42.2 1%
R659	65/6644A	0698-3433	Resistor 28.7 1%
R659	65/6641A, 65/6642A	0698-3432	Resistor 26.1 1%
R659	65/6645A	0757-0397	Resistor 68.1 1%
R660		0698-6977	Resistor 30K .1% .125
R662	65/6643A	0757-0316	Resistor 42.2 1%
R662	65/6644A	0698-3433	Resistor 28.7 1%
R662	65/6641A, 65/6642A	0698-3432	Resistor 26.1 1%
R662	65/6645A	0757-0397	Resistor 68.1 1%
R663		0698-6320	Resistor 5K .1% .125W
R664		0698-0084	Resistor 2.15K 1%
R665		0698-6320	Resistor 5K .1% .125W
R666		0698-6630	Resistor 20K .1%
R667		0698-6630	Resistor 20K .1%
R668		0757-0280	Resistor 1K 1% .125W
R669		0698-0084	Resistor 2.15K 1%
R670		8159-0005	Resistor Zero Ohms
R672	65/6641A-65/6645A	0757-0280	Resistor 1K 1% .125W
R674		0698-3160	Resistor 31.6K 1%
R675	65/6643A-65/6645A	0698-3162	Resistor 46.4K 1%
R675	65/6641A-65/6642A	0757-0459	Resistor 56.2K 1%
R676		0698-3162	Resistor 46.4K 1%
R677	65/6643A, 65/6644A	0698-3150	Resistor 2.37K 1%
R677	65/6641A	0698-4440	Resistor 3.4K 1%
R677	65/6642A	0757-0279	Resistor 3.16K 1%
R677	65/6645A	0698-3150	Resistor 2.37K 1%
R678		0698-8826	Resistor 825K 1%
R679		0757-0280	Resistor 1K 1% .125W
R680	65/6643A-65/6644A	0757-0280	Resistor 1K 1% .125W
R680	65/6641A	0698-0084	Resistor 2.15K 1%
R680	65/6642A	0757-0283	Resistor 2K 1% .125W
R680	65/6645A	0757-0279	Resistor 3.16K 1%
R681	65/6643A-65/6644A	0698-3160	Resistor 31.6K 1%
R681	65/6641A	0698-3162	Resistor 46.4K 1%
R681	65/6642A-65/6645A	0757-0459	Resistor 56.2K 1%
R683		0698-3160	Resistor 31.6K 1%
R684		0757-0442	Resistor 10K 1% .125W
R685		0757-0419	Resistor 681 1% .125W
R690		0757-0416	Resistor 511 1% .125W
R691	65/6643A	0757-0274	Resistor 1.21K 1%
R691	65/6644A	0698-3153	Resistor 3.83K 1%
R691	65/6641A-65/6642A	0757-0280	Resistor 1K 1% .125W
R691	65/6645A	0698-3156	Resistor 14.7K 1%
R692	65/6643A	0757-0274	Resistor 1.21K 1%
R692	65/6644A	0698-3153	Resistor 3.83K 1%

Table 5-5. Parts List For 200 Watt A1 Main Board for Keysight Models 654xA and 664xA (continued)

Reference Desig.	Applicable Models	Keysight Part No.	Description	
R692	65/6641A-65/6642A	0757-0280	Resistor 1K 1% .125W	
R697		0683-1065	Resistor 10M 5% .25W	
R700		0698-3162	Resistor 46.4K 1%	
R701		0698-3162	Resistor 46.4K 1%	
R702		0698-3153	Resistor 3.83K 1%	
R703		65/6641A	0757-0443	Resistor 11K 1% .125W
R703		65/6642A	0757-0452	Resistor 27.4K 1%
R703		65/6643A	0757-0457	Resistor 47.5K 1%
R703		65/6644A	0757-0463	Resistor 82.5K 1%
R703		65/6645A	0757-0470	Resistor 162K 1%
R704		0757-0465	Resistor 100K 1%	
R705	65/6641A	0698-3455	Resistor 261K 1%	
R705	65/6642A, 65/6643A	0698-8827	Resistor 1M 1% .125W	
R705	65/6644A, 65/6645A	0699-0070	Resistor 3.16M 1%	
R706		0757-0419	Resistor 681 1% .125W	
R707		0757-0401	Resistor 100 1% .125W	
R708		0698-0084	Resistor 2.15K 1%	
R709	6541A, 6641A	0757-0316	Resistor 42.2 1%	
R709	65/6642A-65/6644A	0757-0284	Resistor 150 1% .125W	
R711	6541A, 6641A	0757-0316	Resistor 42.2 1%	
R711	65/6642A-65/6645A	0757-0284	Resistor 150 1% .125W	
R712		0698-3155	Resistor 4.64K 1%	
R713		0698-8827	Resistor 1M 1% .125W	
R714	65/6641A	0757-0465	Resistor 100K 1%	
R714	65/6642A, 6543A, 6643A	0698-3459	Resistor 383K 1%	
R714	65/6644A	0698-8826	Resistor 825K 1%	
R714	6645A	0698-8827	Resistor 1M 1% .125W	
R715		0757-0280	Resistor 1K 1% .125W	
R716		0698-0084	Resistor 2.15K 1%	
R717		0698-3441	Resistor 215 1% .125W	
R718		0698-3441	Resistor 215 1% .125W	
R720		0698-3153	Resistor 3.83K 1%	
R721		0757-0280	Resistor 1K 1% .125W	
R722		0757-0280	Resistor 1K 1% .125W	
R723		0698-3260	Resistor 464K 1%	
R724		0698-3260	Resistor 464K 1%	
R725		0698-3155	Resistor 4.64K 1%	
R726		0698-3153	Resistor 3.83K 1%	
R727		0757-0442	Resistor 10K 1% .125W	
R728		0757-0449	Resistor 20K 1% .125W	
R729		0757-0442	Resistor 10K 1% .125W	
R730		0698-0084	Resistor 2.15K 1%	
R731		0698-3260	Resistor 464K 1%	
R732		0698-3155	Resistor 4.64K 1%	
R733		0698-3155	Resistor 4.64K 1%	
R734		0757-0442	Resistor 10K 1% .125W	

Table 5-5. Parts List For 200 Watt A1 Main Board for Keysight Models 654xA and 664xA (continued)

Reference Desig.	Applicable Models	Keysight Part No.	Description
R740		0698-3155	Resistor 4.64K 1%
R741		0698-3155	Resistor 4.64K 1%
R742		0757-0199	Resistor 21.5K 1%
R743		0757-0441	Resistor 8.25K 1%
R744		0757-0280	Resistor 1K 1% .125W
R745		0683-0475	Resistor 4.7 5% .25W
R746		0698-3162	Resistor 46.4K 1%
R747		0757-0199	Resistor 21.5K 1%
R748		0757-0199	Resistor 21.5K 1%
R749		0757-0199	Resistor 21.5K 1%
R750		0757-0280	Resistor 1K 1% .125W
R75 1		0683-0475	Resistor 4.7 5% .25W
R752		0698-3160	Resistor 31.6K 1%
R753		0757-0465	Resistor 100K 1%
R754		0698-8816	Resistor 2.15 1%
R770		0757-0442	Resistor 10K 1% .125W
R771		0757-0442	Resistor 10K 1% .125W
R772		0698-6979	Resistor 111.1K .1%
R773		0698-6376	Resistor 200K .1%
R774		0698-7842	Resistor 26.1K .1%
R775		0698-6630	Resistor 20K .1%
R778		0698-3629	Resistor 270 5% 2W MO
R781		0686-2225	Resistor 2.2K 5% .5W
R785		0757-0405	Resistor 162 1% .125W
R901	65/6641A	8159-0005	Resistor Zero Ohms
R903	65/6643A	8159-0005	Resistor Zero Ohms
R904	65/6644A	8159-0005	Resistor Zero Ohms
R905	6645A	8159-0005	Resistor Zero Ohms
RT301	65/6642A-65/6645A	06652-60006	Assy, Thermistor
RT770	65/6642A-65/6645A	0837-0412	Thermistor
S400		3101-2966	SW-SL DPDT
S401		3101-2966	SW-SL DPDT
S610		3101-2894	SW-PB DPDT
U201		1826-1533	IC 34072
U202		1826-1533	IC 34072
U301		1826-1533	IC 34072
U302		1826-1533	IC 34072
U502		5080-2150	PRGMD-GAL,MAIN
U503		1826-1370	IC 365
U504		5080-2250	PRGMD IC, SEC
U505		1826-1369	IC-Voltage regulator
U506		1826-1533	IC 34072
U507		1826-2187	IC-Converter, D/A
U508		1826-1896	IC-Linear
U509		1826-2187	IC-Converter, D/A
U510		1826-1896	IC-Linear
U511		1826-2187	IC-Converter, D/A

Table 5-5. Parts List For 200 Watt A1 Main Board for Keysight Models 654xA and 664xA (continued)

Reference Desig.	Applicable Models	Keysight Part No.	Description	
U512	65/6641A-65/6644A	1826-1896	IC-Linear	
U513		1826-1370	IC 365	
U600		5060-3321	Regulator (1826-0126)	
U601		5060-3320	Regulator (1826-0122)	
U602		5060-3229	Regulator (1826-0214)	
U603		1826-1533	IC 34072	
U605		1826-2252	IC OP270GP	
U606		1826-1878	IC-72	
U607		1826-1533	IC 34072	
U608		1826-1370	IC 365	
U609		1826-1533	IC 34072	
U610		1826-1533	IC 34072	
U700		1990-0543	Optical isolator	
U720		1826-0468	IC MC3423PI	
U721		1858-0047	XSTR ARY 16P-DIP	
U740		1858-0076	XSTR ARY 14P-DIP	
U741		1858-0077	XSTR ARY 14P DIP	
VR510		65/6642A	1902-0958	Diode Zener 10V 5%
VR511			1902-0958	Diode Zener 10V 5%
VR610			65/6642A	1902-0958
VR611	65/6642A		1902-0958	Diode Zener 10V 5%
VR720	.		1902-0947	Diode Zener 3.6V 5%
VR721	.		1902-0947	Diode Zener 3.6V 5%
VR770	.		1902-0955	Diode Zener 7.5V 5%
VR771	.		1902-0958	Diode Zener 10V 5%
Y501	.		0410-2109	XTAL 12.000 MHZ
Z610	.		1902-0958	Diode Zener 10V 5%
Z611	.	1902-0958	Diode Zener 10V 5%	
Z720	.	1902-0947	Diode Zener 3.6V 5%	
Z721	.	1902-0947	Diode Zener 3.6V 5%	
Z770	.	1902-0955	Diode Zener 7.5V 5%	
Z771	.	1902-0958	Diode Zener 10V 5%	

Table 5-6. Parts List For 500 Watt 655xA & 665xA Main Chassis

Reference Desig.	Applicable Models	Keysight Part No.	Description
B1		5060-3436	Fan, 4-inch, tubeaxial, 12Vdc
F450		2110-0054	Fuse 15AM, 250V (for 100 Vac line)
F450		2110-0249	Fuse 12AM, 250V (for 120 Vac line)
F450		2110-0614	Fuse 7AM, 250V (for 220/240 Vac line)
T1	65/6651A	9100-4900	Power Transformer
	65/6652A	9100-4845	Power Transformer
	65/6653A	9100-4848	Power Transformer
	65/6654A	9100-4846	Power Transformer
	65/6655A	9100-4899	Power Transformer
W1A		06652-80006	AC cable (A1J450/A3S1)
W1B		06652-80007	AC cable (A3S1/T1)
W2	65/6651A	06652-80004	+Rail (T1/A1J404)
	65/6652A	06652-80004	+Rail (T1/A1J401)
	65/6653A-65/6655A	06654-80001	+Rail (T1/A1J411)
W3	65/6651A-65/6653A	06652-80003	Rail (T1/A1J405)
	65/6654A, 65/6655A	06654-80003	Rail (T1/A1J405)
W4	65/6651A-65/6653A	06652-80005	Center Tap (T1/A1J403)
	65/6654A, 65/6655A		Not Used
W5	65/6651A	06652-80005	Center Tap (T1/A1J402)
	65/6652A-65/6655A		Not Used
W6	65/6651A	06652-80004	+Rail (T1/A1J401)
	65/6652A	06652-80004	+Rail (T1/A1J404)
	65/6653A, 65/6654A		Not used
W7		06652-80009	AC bias (T1/A1J600)
W8		06652-80008	GPIB bias (T1/A2P101)
W9		06652-80010	Phone cable (A1J501/A2J107)
W10		06652-80011	Phone cable (A2J108/A3A1J6)
W 11		06652-80010	Phone cable (A1J670/A4A1J201)
W12		06652-80001	+Rail,-Rail, +Out (A1/A4A1J202)
W13		06652-80011	Phone cable (A1J672/A4A2J301)
W14		06652-80002	+Rail, -Rail, +Out (A1/A4A2J302)
W15		06652-80010	Phone cable (A1J671/A4A3J201)
W16		06652-80001	+Rail, -Rail, +Out (A1/A43J202)
W17		06652-80011	Phone cable (A1J673/A4A4J301)
W18		06652-80002	+Rail, -Rail, +Out (A1/A4A4J302)
W19		5080-2261	Ribbon cable (A3A1J2/LCD display)
A1	65/6651A	06651-61020	Main PCB Tested
	65/6652A	06652-61020	Main PCB Tested
	65/6653A	06653-61020	Main PCB Tested
	65/6654A	06654-61020	Main PCB Tested
	65/6655A	06655-61020	Main PCB Tested
A2	6551A-6555A	5060-3398	Isolator Board Tested
A2	6651A-6655A	5060-3399	GPIB Board PCA Tested (surface mount, see Table 5-9A)
A2	6651A-6655A	5060-3317	GPIB Board PCA Tested (through-hole, see Table 5-9B)
A3		5060-3400	Front Panel Board Unitialized and Tested
A3	6551A	06551-61001	Front Panel Board Initialized & Tested
A3	6552A	06552-61001	Front Panel Board Initialized & Tested
A3	6553A	06553-61001	Front Panel Board Initialized & Tested
A3	6554A	06554-61001	Front Panel Board Initialized & Tested

Table 5-6. Parts List For 500 Watt 655xA & 665xA Main Chassis (continued)

Reference Desig.	Applicable Models	Keysight Part No.	Description
A3	6555A	06555-61001	Front Panel Board Initialized & Tested
	6551A	06551-80001	Name plate
	6552A	06552-80014	Name plate
	6553A	06553-80001	Name plate
	6554A	06554-80002	Name plate
	6555A	06555-80001	Name plate
	6651A	06651-80001	Name plate
	6652A	06652-80014	Name plate
	6653A	06653-80001	Name plate
	6654A	06654-80002	Name plate
	6655A	06655-80001	Name plate
DSP1 GI,G2		5063-2304	LCD Display
		0960-0912	Optical Encoders (Rotary V and I controls)
		5040-1665	Keypad
		5063-3407	PCA Keypad
S1 A4 A4AI		3101-3088	AC line on/off switch
			Heat sink assembly
A4A2			Top Left Tunnel Board
	65/6651A	06651-61022	Left Tunnel Board
	65/6652A	06652-61022	Left Tunnel Board
	65/6653A	06653-61022	Left Tunnel Board
	65/6654A	06654-61002	Left Tunnel Board
	65/6655A	06655-61022	Left Tunnel Board
			Top Right Tunnel Board
	65/6651A	06651-61023	Right Tunnel Board
	65/6652A	06652-61023	Right Tunnel Board
	65/6653A	06653-61023	Right Tunnel Board
A4A3 A4A4 A4RT301	65/6654A	06654-61023	Right Tunnel Board
	65/6655A	06655-61023	Right Tunnel Board
			Bottom Left Tunnel Board (same as A4A1)
			Bottom Right Tunnel Board (same as A4A2)
		06652-60006	Thermistor assy (mounted on right hand top side of heat sink assy)
		5062-3704	Strap handle
		5041-8819	Cap - strap handle, front
		5041-8820	Cap- strap handle, rear
		5001-6748	Front panel dress
		5040-1703	Front frame
	0515-0413	Screw mach M4 x 0.7 6 mm lg pan head (ref rear panel, xfmr bracket, GPIB board)	
	5001-6771	Rear panel	
	06652-00004	Cover top	
	06652-00007	Bracket-transformer	
	06652-00008	Shroud for heat sink	
	06652-20001	Heat sink (ref A4 top and bottom)	
	06652-60001	Chassis	
	06652-60005	Jumper assy (ref xfmr T1)	
	1400-0493	Cable tie (ref bias cable to front bracket)	
	1400-0528	Mount cable tie (ref front bracket)	

Table 5-6. Parts List For 500 Watt 655xA & 665xA Main Chassis (continued)

Reference Desig.	Applicable Models	Keysight Part No.	Description
		5041-8801	Foot
		0360-2191	Cover, terminal block
		0361-1240	Rivet-blind (ref GPIB bracket to chassis)
		0370-2862	Pushbutton (ref sense switch S610)
		2110-0565	Fuseholder Cap (ref XFMR 450)
		0515-0106	Screw-mach M4 x .7 8mm lg (ref bus bar, AC gnd, shroud to base)
		0515-1655	Screw mach M4 x 0.7 12mm lg (HS rails, PCB gnd)
		0535-0031	Hex nut with lockwasher (ref fan top shroud)
		0535-0082	Hex nut (shroud to base, AC gnd)
		0515-1132	Screw mach M5 x 0.8 10 mm lg (ref top cover)
		0515-1105	Screw mach M3 x 0.5 10 mm lg (front frame to chassis)
		0515-0911	Screw mach M3 x 0.5 12 mm lg (fan to shroud ,thermistor)
		0515-0909	Screw mach M4 x 0.712 mm lg (HS rails, PCB ground)
		3050-0893	Washer (HS rails, GPIB, safety cover)
	6651A-6655A	0160-0895	RFI strip (ref top cover)
		5001-0539	Side trim strips
		5040-1666	Hs rail
		5040-1667	HS bumper
		3050-1053	Washer fl mtlc (ref fan to shroud)
		2190-0586	Washer lk hlcl (ref HS rails, PCB gnd)
		2190-0646	Washer lk (ref AC gnd)
		1400-0493	Cable tie (ref tunnel cables, AC bias cable)
		1400-1281	Cable clip (ref tunnel, AC power cables)
		1400-0611	Cable clamp (ref front panel phone cable)
		0370-3238	Knobs (ref A3GI, A3G2)
		5001-6740	GPIB board bracket
		1510-0044	Binding post
		1000-0842	Window (ref front panel display)
		0590-0534	Nut self-thd (ref display to front panel)
		1252-1488	Quick-disconnect mating plug for DIG CNTL connector A2TB101
		1252-3698	Quick-disconnect mating plug for external connector AIJ640
		5080-2148	Chaining cable for power supply link
		5959-3317	operating Manual
		9211-5869	Shipping carton
		9222-0456	Bag cushioned
		9222-1363	Bag static
		5080-2120	Foam pad
		5080-2211	Label

Table 5-7. Parts List For 500 Watt A1 Main Board for 655xA & 665xA

Reference Desig.	Applicable Models	Keysight Part No.	Description
C403	65/6651A, 65/6652A	0160-5422	Capacitor .047 uF 20%
	65/6653A-65/6655A		Not used
C404	65/6651A, 65/6652A		Not used
	65/6654A, 65/6655A		Not used
	65/6653A	0160-6803	Capacitor .047 250V
C405,406	65/6651A	0180-4321	Capacitor 39000 uF 25V
	65/6652A	0160-4264	Capacitor 18000 uF 50V
	65/6653A	0180-4272	Capacitor 10000 uF 80V
	65/6654A	0180-4263	Capacitor 4000 uF 125V
	65/6655A	0180-4311	Capacitor 1200 uF 250V
C407	65/6651A	0180-4321	Capacitor 39000 uF 25V
	65/6652A	0160-4264	Capacitor 18000 uF 50V
	65/6653A	0180-4272	Capacitor 10000 uF 80V
	65/6654A, 65/6655A		Not used
C408,409	65/6651A	0180-4321	Capacitor 39000 uF 25V
	65/6652A-65/6655A		Not used
C411	65/6651A, 65/6652A	0160-5422	Capacitor .047 uF 20%
	65/6653A-65/6655A		Not used
C412	65/6651A, 65/6652A		Not used
	65/6654A, 65/6655A		Not used
	65/6653A	0160-6803	Capacitor .047 uF 250V
	65/6652A, 65/6654A		Not used
C413	65/6651A-65/6653A,	0160-5469	Capacitor 1uF 10% 50V
	65/6655A		
	65/6654A	0160-5101	Capacitor 1 uF 10%
C414,415		0160-5422	Capacitor .047 uF 20%
C416	65/6651A	0180-4321	Capacitor 39000 uF 25V
	65/6652A, 65/6653A	0180-3963	Capacitor 17000 uF 16V
	65/6654A		Not used
C417	65/6651A-65/6653A		Not Used
	65/6654A, 65/6655A	0180-3497	Capacitor 6800 uF 16V
C418	65/6651A-65/6653A		Not Used
	65/6654A	0160-0168	Capacitor .1 uF 10%
	65/6655A	0160-4065	Capacitor .1 uF 10%
C450, 451		0160-4281	Capacitor 2200 pF 20%
C452		0160-4962	Capacitor 1.0 uF 20%
C501		0160-5422	Capacitor .047 uF 20%
C502,503		0160-4805	Capacitor 47 pF 5% 100V
C504		0160-5422	Capacitor .047 uF 20%
C505	65/6651A-65/6655A	0160-4129	Capacitor 1 uF 35V
C506		0160-4801	Capacitor 100 pF 5%
C507		0160-5422	Capacitor .047 uF 20%
C509		0160-5422	Capacitor .047 uF 20%
C510		0160-4801	Capacitor 100 pF 5%
C512		0160-5422	Capacitor .047 uF 20%
C513		0160-4801	Capacitor 100 pF 5%
C515		0160-5422	Capacitor .047 uF 20%
C516		0160-4801	Capacitor 100 pF 5%

Table 5-7. Parts List For 500 Watt A1 Main Board for 655xA & 665xA (continued)

Reference Desig.	Applicable Models	Keysight Part No.	Description
C517,518		0160-5422	Capacitor .047 uF 20%
C519	65/6651A-65/6655A	0180-4129	Capacitor 1 uF 35V
C520-522		0160-5098	Capacitor .22 uF 10%
C523			Not used
C524		0160-5422	Capacitor .047 uF 20%
C600		0160-4834	Capacitor .047 uF 10% 100V
C602		0180-3458	Capacitor 4700 uF 50V
C603		0180-3298	Capacitor 2200 uF 50V
C604,606	65/6651A-65/6655A	0180-4129	Capacitor 1 uF 35V
C605		0180-0197	Capacitor 2.2 uF 20V TA
C610		0160-5469	Capacitor 1 uF 10% 50V
C611		0160-4808	Capacitor 470 pF 5%
C612		0160-4835	Capacitor .1 uF 10% 50V
C613,614	65/6651A	0160-4835	Capacitor 0.1 uF 10% 50V
	65/6652A	0160-5422	Capacitor 0.047 uF 20%
	65/6653A	0160-5166	Capacitor 0.015 uF 20%
	65/6654A	0160-5409	Capacitor 3000 pF 5%
C615-618		0160-5422	Capacitor 0.047 uF 20%
C619	65/6651A, 65/6653A	0160-4791	Capacitor 10 pF 5% 100V
	65/6652A	0160-4795	Capacitor 4.7 pF
	65/6654A, 65/6655A	0160-4789	Capacitor 15 pF 5% 100V
C620			Not used
C621		0160-4821	Capacitor 1200 pF 5%
C622	65/6651A, 65/6653A	0160-4791	Capacitor 10 pF 5% 100V
	65/6652A	0160-4795	Capacitor 4.7 pF
	65/6654A, 65/6655A	0160-4789	Capacitor 15 pF 5% 100V
C623	65/6651A, 65/6652A	0160-4801	Capacitor 100 pF 5% 100V
	65/6653A-65/6655A		Not used
C624	65/6651A, 65/6652A, 65/6655A	0160-4788	Capacitor 18 pF 5% 100V
	65/6653A, 65/6654A	0160-4791	Capacitor 10 PF 5% 100V
C640		0180-6827	Capacitor 0.022 uF 400V
C641		0160-0161	Capacitor 0.01 uF 10%
C642	65/6651A, 65/6652A	0160-4813	Capacitor 180 PF 5%
	65/6653A, 65/6654A	0160-4803	Capacitor 68 PF 1
	65/6655A	0160-4805	Capacitor 47 pF 5% 100V
C643,644			Capacitor .047 uF 20%
C645		0160-4355	Capacitor 0.01 uF 10%
C646	65/6651A, 65/6652A	0160-4805	Capacitor 47 uF
	65/6652A-65/6654A		Not used
C671		0160-4791	Capacitor 10 pF 5% 100V
C672	65/6651A, 65/6655A	0160-4807	Capacitor 33 pF 5% 100V (mounted on pins)
	65/6652A-65/6654A	0160-4807	Capacitor 33 pF 5% 100V (in D673 location)
C673-689			Not used

Table 5-7. Parts List For 500 Watt A1 Main Board for 655xA & 665xA (continued)

Reference Desig.	Applicable Models	Keysight Part No.	Description
C690	65/6651A		Not used
	65/6652A	0180-2728	Capacitor 1100 uF 40V
	65/6653A	0180-3382	Capacitor 440 uF 50V
	65/6654A	0180-3685	Capacitor 120 uF 100V
	65/6655A	0180-3653	Capacitor 56 uF 200V
C691	65/6651A-65/6653A	0160-5422	Capacitor 0.047 uF 20% 50V
	65/6654A	0180-4834	Capacitor 0.047 uF 10% 100V
	65/6655A	0160-0159	Capacitor 6800 pF 10%
C692,693		0160-4355	Capacitor 0.01 uF 10%
C694		0160-5410	Capacitor 3300 pF 5% 50V
C695	65/6651A	0180-4346	Capacitor fixed 10000 uF
	65/6652A-65/6655A		Not used
C700,701		0160-5422	Capacitor 0.047 uF 20%
C702		0160-4812	Capacitor 220 pF 5%
C703-705		0160-5422	Capacitor 0.047 uF 20%
C706		0160-4832	Capacitor 0.01 uF 10%
C707		0160-5422	Capacitor 0.047 uF 20%
C708	65/6651A, 65/6655A	0160-4832	Capacitor 0.01 uF 10%
	65/6652A-65/6654A		Not used
C720	65/6651A, 65/6655A	0180-4136	Capacitor 10 uF 20V
	65/6652A-65/6654A	0180-0374	Capacitor 10 uF 20V
C740	65/6651A-65/6654A	0160-4831	Capacitor 4700 PF 10%
	65/6655A		Not used
C741		0160-4801	Capacitor 100 pF 5%
C742	65/6651A, 65/6655A	0180-0197	Capacitor 2.2 uF 20V TA
	65/6652A-65/6654A		Not used
C770	65/6651A, 65/6655A	0180-4136	Capacitor 10 uF 20V
	65/6652A-65/6654A	0180-0374	Capacitor 10 uF 20V
C771		0160-4830	Capacitor 2200 pF 10%
C772	65/6651A, 65/6655A	0180-4132	Capacitor 6.8 uF 35V
	65/6652A-65/6654A	0180-0116	Capacitor 6.8 uF 35V
CR700	65/6651A-65/6653A	1884-0349	Thyristor SCR
CR701	65/6654A, 65/6655A	1884-0340	Thyristor SCR
D400	65/6651A	1901-1127	Diode pwr rect
	65/6652A	1901-1333	Diode pwr rect
	65/6653A-65/6655A		Not used
D402	65/6651A, 65/6652A		Not used
	65/6653A-65/6655A	1906-0383	Diode bridge
D403			Not used
D404	65/6651A	1901-1127	Diode pwr rect
	65/6652A	1901-1333	Diode pwr rect
	65/6653A-65/6655A		Not used
D405	65/6651A	5060-3228	Assy-HS (includes diode 1901-0987)
	65/6652A, 65/6653A	1901-0987	Diode pwr rect
	65/6654A, 65/6655A		Not used
D406,407	65/6651A-65/6653A		Not used
	65/6654A, 65/6655A	1901-0719	Diode
D408	65/6651A	5060-3228	Assy-HS (includes diode 1901-0987)
	65/6652A, 65/6653A	1901-0987	Diode pwr rect
	65/6654A, 65/6655A		Not used

Table 5-7. Parts List For 500 Watt A1 Main Board for 655xA & 665xA (continued)

Reference Desig.	Applicable Models	Keysight Part No.	Description
D409		1901-1087	Diode pwr rect
D600-603		1901-0731	Diode pwr rect
D604-606		1901-1098	Diode IN4150
D610-614		1901-0033	Diode
D615-619		1901-1098	Diode IN4150
D640,641		1901-0033	Diode
D643-650		1901-0033	Diode
D651		1901-1098	Diode IN4150
D670-672		1901-1098	Diode IN4150
D673	65/6651A, 65/6655A 65/6652A-65/6654A	1901-1098	Diode IN4150 Not used
D674-676		1901-0731	Diode pwr rect
D677-689			Not used
D690	65/6651A 65/6652A-65/6653A	1901-1127	Diode pwr rect
D691	65/6654A, 65/6655A	1901-0317	Diode pwr IN1184A
D700		1901-1383	Diode pwr
F400,401	65/6651A 65/6652A-55	1901-0033	Diode
F402,403		2110-0765	Fuse 20AT, 250V Not used
F600,601		2110-0697	Fuse submin 15AM, 32V
J401	65/6651A, 65/6652A 65/6653A, 65/6654A, 65/6655A	2110-0685	Fuse submin 7AM, 125V
J402	65/6651A 65/6652A-55	1251-4781	Connector-util (+Rail) Not used
J403	65/6651A-65/6653A 65/6654A, 65/6655A	1251-4781	Connector-util (center tap) Not used
J404	65/6651A, 65/6652A 65/6653A-65/6655A	1251-4781	Connector-util (center tap) Not used
J405		1251-4781	Connector-util (+Rail) Not used
J411	65/6651A , 65/6652A 65/6653A-65/6655A	1251-4781	Connector-util (-Rail) Not used
J450		1251-4781	Connector-util (+Rail)
J451		1251-7616	Connector-util (On/Off switch)
J501		1252-3771	Connector AC input
J600		1251-8184	Phone Jack (serial data)
J601		1251-4246	Connector-test
J640		1251-4245	Connector-fan
J670-673		1252-3693	Connector-control (external)
J690,691		1251-8184	Phone jack (Tunnel boards)
Q670		06652-00005	Bus bar
Q700		1854-0872	Transistor, NPN
Q770		1854-0477	Transistor, NPN 2N2222A
R403	65/6651A-65/6653A 65/6654A, 55	5060-3322	Assy (includes XSTR and HS)
R404		8159-0005	Resistor 0 Ohms Not used Not used

Table 5-7. Parts List For 500 Watt A1 Main Board for 655xA & 665xA (continued)

Reference Desig.	Applicable Models	Keysight Part No.	Description
R405	65/6651A-65/6653A 65/6654A, 65/6655A	8159-0005	Resistor 0 Ohms Not used
R407,408			Not used
R409	65/6651A 65/6652A 65/6653A-65/6655A	0811-1857	Not used Resistor 400 5% 5W PW Not used
R410	65/6651A 65/6652A-55	0810-0018	Not used Resistor 100 3% 5W PW Not used
R411	65/6651A-65/6653A 65/6654A 65/6655A	0811-1873 0811-1914	Not used Resistor 3K 5% 10W PW Resistor 5K 5% 10W PW
R412	65/6651A 65/6652A-55	0813-0050 0811-1799	Resistor 100 5% 3W PW Resistor 390 5% 3W PW
R413		0757-0280	Resistor 1K 1% .125
R414	65/6651A, 65/6652A 65/6653A 65/6654A 65/6655A	0811-0944 0811-1873 0811-1914	Not used Resistor 800 5% 10W Resistor 3K 5% 10W PW Resistor 5K 5% 10W PW
R415			Not used
R416	65/6651A-65/6653A 65/6654A, 65/6655A	8159-0005	Not used Resistor 0 Ohms
R450		0698-8827	Resistor 1M 1% .125W
R501		0698-3456	Resistor 287K 1%
R502		1810-0305	Resistor network (4.7K)
R504		0757-0458	Resistor 51.1K 1%
R505		0750-0428	Resistor 1.62K 1%
R506		0699-1212	Resistor 19K.1%
R507		0698-6392	Resistor 22K .1% .125W
R508		0750-0442	Resistor 10K 1% .125W
R509-511		0757-0401	Resistor 100 1% .125W
R512		0698-3456	Resistor 287K 1%
R513, 514		0757-0465	Resistor 100K 1%
R515		0757-0462	Resistor 75K 1% .125W
R516-518		0698-0084	Resistor 2.15K 1%
R520		0698-3155	Resistor 4.64K 1%
R600		0811-3849	Resistor .25 Ohms 5% 3W
R60 1			Not used
R605-607		8159-0005	Resistor 0 Ohms
R610		0698-6360	Resistor 10K .1%
R611		0698-6343	Resistor 9K .1% .125W
R612		0757-0442	Resistor 10K 1% .125W
R613		0698-6630	Resistor 20K .1%
R614,615		0698-3156	Resistor 14.7K 1%
R616		0683-2255	Resistor 2.2M 5% .25W
R617		0757-0279	Resistor 3.16K 1%
R618		0757-0441	Resistor 8.25K 1%

Table 5-7. Parts List For 500 Watt A1 Main Board for 655xA & 665xA (continued)

Reference Desig.	Applicable Models	Keysight Part No.	Description
R619	65/6651A-65/6653A, 65/6655A	0698-0082	Resistor 464 1% .125W
R620,621		0757-0449	Resistor 20K 1% .125W
R622		0699-2246	Resistor 25K .05%
R623	65/6654A	0699-2248	Resistor 47.5K .05%
	65/6651A	0699-3103	Resistor 19K .05%
	65/6652A	0699-2298	Resistor 47.5K .05%
	65/6653A	0699-2879	Resistor 80K .05%
	65/6654A	0699-2198	Resistor 243K .05%
	65/6655A	0699-3104	Resistor 250K .05%
R624	65/6651A	0698-6362	Resistor 1K .1%
	65/6652A	0698-6631	Resistor 2.5K .1%
	65/6653A	0698-6614	Resistor 7.5K .1%
	65/6654A	0699-2198	Resistor 42K .1%
	65/6655A	0698-6353	Resistor 50K .1%
R625	65/6651A-65/6653A, 65/6655A	0699-2246	Resistor 25K .05%
R626	65/6654A	0699-2248	Resistor 47.5K .05%
	65/6651A	0699-3103	Resistor 19K .05%
	65/6652A	0699-2248	Resistor 47.5K .05%
	65/6653A	0699-2879	Resistor 80K .05% 5ppm 1W
	65/6654A	0699-2198	Resistor 243K .05%
	65/6655A	0699-3104	Resistor 250K .05%
R627	65/6651A	0698-6362	Resistor 1K .1%
	65/6652A	0698-6631	Resistor 2.5K .1%
	65/6653A	0698-6614	Resistor 7.5K .1%
	65/6654A	0698-3988	Resistor 42K .1%
	65/6655A	0698-6353	Resistor 50K .1%
R628		0698-6320	Resistor 5K .1% .125W
R629		0757-0481	Resistor 475K 1%
R630		0698-4470	Resistor 6.98K 1%
R631		0698-4014	Resistor 787 1% .125W
R632		0698-3156	Resistor 14.7K 1%
R633		0698-3162	Resistor 46.4K 1%
R635		0698-6320	Resistor 5K .1% .125W
R636			Not used
R637	65/6651A, 65/6652A, 65/6655A	0757-0442	Resistor 10K 1% .125W
R639	65/6653A, 65/6654A	0698-3155	Resistor 4.64K
		0698-3456	Resistor 287K 1%
R640		0698-6343	Resistor 9K .1%
R641		0698-8061	Resistor 8.25K .1%
R642		0757-0442	Resistor 10K 1% .125W
R643		0698-6630	Resistor 20K .1%
R644		0698-3156	Resistor 14.7K 1%
R645		0757-0280	Resistor 1K 1% .125W

Table 5-7. Parts List For 500 Watt A1 Main Board for 655xA & 665xA (continued)

Reference Desig.	Applicable Models	Keysight Part No.	Description
R646	65/6651A, 65/6652A	0699-1156	Resistor 72K .1%
	65/6653A, 65/6654A	0698-6353	Resistor 50K .1%
	65/6655A	0698-6359	Resistor 80K 1%
R647,648		0698-6344	Resistor 900 .1%
R649,650		0698-6320	Resistor 5K .1% .125W
R651,652		0698-6630	Resistor 20K .1%
R653		0698-6320	Resistor 5K .1% .125W
R654		0698-0084	Resistor 2.15K 1%
R655		0698-6320	Resistor 5K .1% .125W
R656		0698-3156	Resistor 14.7K 1%
R657	65/6651A	06651-20002	Resistor .0027 (current monitor)
	65/6652A	5080-2007	Resistor .005 (current monitor)
	65/6653A	5080-2079	Resistor .013 (current monitor)
	65/6654A	06654-80004	Resistor .020 (current monitor)
	65/6655A		Resistor .028125 (current monitor)
R658		0757-0458	Resistor 51.1K 1%
R659	65/6651A, 65/6652A	0698-4395	Resistor 78.7K 1%
	65/6653A	0757-0398	Resistor 75 1% .125W
	65/6654A, 65/6655A	8159-0005	Resistor 0
R660	65/6651A, 65/6652A	0699-1156	Resistor 72K .1%
	65/6653A, 65/6654A, 65/6655A	0698-6353	Resistor 50K .1%
R661			Not used
R662	65/6651A, 65/6652A	0698-4395	Resistor 78.7 1%
	65/6653A	0757-0398	Resistor 75 1% .125W
	65/6654A, 55	8159-0005	Resistor 0
R663		0698-6320	Resistor 5K .1% .125W
R664		0698-0084	Resistor 2.15K 1%
R65/665		0698-6320	Resistor 5K .1% .125W
R666,667		0698-6630	Resistor 20K .1%
R668		0757-0280	Resistor 1K 1% .125W
R669		0698-0084	Resistor 2.15K 1%
R670		8159-0005	Resistor 0 Ohms
R671			Not used
R672		0757-0280	Resistor 1K 1% .125W
R674		0698-3160	Resistor 31.6K 1%
R675	65/6651A	0757-0458	Resistor 51.1K 1%
	65/6652A, 65/6654A, 65/6655A	0757-0459	Resistor 56.2K 1%
	65/6653A	0754-0457	Resistor 47.5K 1%
R676		0698-3162	Resistor 46.4K 1%
R677	65/6651A, 65/6652A	0698-3558	Resistor 4.02K 1%
	65/6653A	0757-0279	Resistor 3.16K 1%
	65/6654A	0698-4440	Resistor 3.4K 1%
	65/6655A	0698-3496	Resistor 3.57K
R678		0698-8826	Resistor 825K 1%
R679		0757-0280	Resistor 1K 1% .125W

Table 5-7. Parts List For 500 Watt A1 Main Board for 655xA & 665xA (continued)

Reference Desig.	Applicable Models	Keysight Part No.	Description
R680	65/6651A	0698-0084	Resistor 2.15K 1%
	65/6652A	0757-0283	Resistor 2K 1% .125W
	65/6653A, 65/6654A	0757-0280	Resistor 1K 1% .125W
	65/6655A	0757-0279	Resistor 3.16K 1%
R681	65/6651A	0698-3162	Resistor 46.4K 1%
	65/6652A, 65/6655A	0757-0459	Resistor 56.2K 1%
	65/6653A, 65/6654A	0698-3160	Resistor 31.6K 1%
R682		0757-0401	Resistor 100 1% .125W
R683		0698-3160	Resistor 31.6K 1%
R684		0757-0442	Resistor 10K 1% .125W
R685		0757-0419	Resistor 681 1% .125W
R686,687		8159-0005	Resistor 0 Ohms
R690		0698-0082	Resistor 464 1% .125W
R691,692	65/6651A, 65/6652A	0757-0280	Resistor 1K 1% .125W
	65/6653A	0757-0274	Resistor 1.21K 1% .125W
	65/6654A	0698-3153	Resistor 3.83K 1% .125W
	65/6655A	0698-3156	Resistor 14.7K 1% .125W
R693,694			Not used
R695	65/6651A	0811-1899	Resistor 25 5% 10 W
	65/6652A	0811-1903	Resistor 100 5% 10 W
	65/6653A	0811-0054	Resistor 300 5% 10 W
	65/6654A	0811-1586	Resistor 1K 5% 10 W
	65/6655A	0811-1873	Resistor 3K 5% 10 W
R696,697		0683-1065	Resistor 10 M 5% .25W
R700,701		0698-3162	Resistor 46.4K 1%
R702		0698-3153	Resistor 3.83K 1%
R703	65/6651A	0757-0443	Resistor 11K 1%
	65/6652A	0757-0452	Resistor 27.4K 1%
	65/6653A	0757-0457	Resistor 47.5K 1%
	65/6654A	0757-0463	Resistor 82.5K 1%
	65/6655A	0757-0470	Resistor 162K 1%
R704		0757-0465	Resistor 100K 1%
R705			Resistor 215K 1%
	65/6651A	0698-3454	
	65/6652A-65/6654A	0698-8827	Resistor 1M 1% .125W
	65/6655A	0699-0070	Resistor 3.16M 1%
R706		0757-0419	Resistor 681 1% .125W
R707		0757-0401	Resistor 100 1% .125W
R708		0698-0084	Resistor 2.15K 1%
R709		0757-0284	Resistor 150 1% .125W
R710			Not used
R711		0757-0284	Resistor 150 1% .125W
R712		0698-3155	Resistor 4.64K 1%
R713		0698-8827	Resistor 1M 1% .125W
R714	65/6651A	0698-3572	Resistor 60.4K 1%
	65/6652A	0757-0452	Resistor 27.4K 1%
	65/6653A	0698-8820	Resistor 825K 1%
	65/6654A	0698-3260	Resistor 464K 1%
	65/6655A	0699-0070	Resistor 3.16M 1%

Table 5-7. Parts List For 500 Watt A1 Main Board for 655xA & 665xA (continued)

Reference Desig.	Applicable Models	Keysight Part No.	Description
R715		0757-0280	Resistor 1K 1% .125W
R716		0698-0084	Resistor 2.15K 1%
R717,718		0698-3441	Resistor 215 1% .125W
R719			Not used
R720		0698-3151	Resistor 3.83K 1%
R721,722		0757-0280	Resistor 1K 1% .125W
R723,724		0698-3260	Resistor 464K 1%
R725		0698-3155	Resistor 4.64K 1%
R726		0698-3153	Resistor 3.83K 1%
R727		0757-0442	Resistor 10K 1% .125W
R728		0757-0449	Resistor 20K 1% .125W
R729		0757-0442	Resistor 10K 1% .125W
R730		0698-0084	Resistor 2.15K 1%
R731		0698-3260	Resistor 464K 1%
R732,733		0698-3155	Resistor 4.64K 1%
R734		0757-0442	Resistor 10K 1% .125W
R740,741		0698-3155	Resistor 4.64K 1%
R742		0757-0199	Resistor 21.5K 1%
R743		0757-0441	Resistor 8.25K 1%
R744		0757-0280	Resistor 1K 1% .125W
R745		0683-0475	Resistor 4.7 5% .25W
R746		0698-3162	Resistor 46.4K 1%
R747-749		0757-0199	Resistor 21.5K 1%
R750		0757-0280	Resistor 1K 1% .125W
R751		0683-0475	Resistor 4.7 5% .25W
R752		0698-3160	Resistor 31.6K 1%
R753		0757-0465	Resistor 100K 1%
R754	65/6651A, 65/6655A 65/6652A-65/6654A	0698-8816	Resistor 2.15 1% Not used
R770,771		0757-0442	Resistor 10K 1% .125W
R772		0757-0470	Resistor 162K 1%
R773		0698-6376	Resistor 200K .1%
R774		0699-1212	Resistor 19K .1%
R775		0698-6630	Resistor 20K .1%
R778-779		0811-2201	Resistor 270 5% 2W PW
R781		0686-2225	Resistor 2.2K 5% .5W
R783, 784, R786-788	65/6651A-65/6653A		Not used
R783, 784, R786-788	65/6654A, 65/6655A	8159-0005	Resistor 0 Ohms
R785	65/6651A 65/6652A-65/6655A	0757-0405 0757-0397	Resistor 162 1% Resistor 68.1 1%
R790			Not used
R789,791	65/6651A 65/6652A-65/6655A	8159-0005	Not used Resistor 0 Ohms
R792			Not used
R793	65/6651A-65/6653A 65/6654A, 65/6655A	8159-0005	Not used Resistor 0 Ohms

Table 5-7. Parts List For 500 Watt A1 Main Board for 655xA & 665xA (continued)

Reference Desig.	Applicable Models	Keysight Part No.	Description
RT770		0837-0412	Thermistor
S610		3101-2894	Switch-PB DPDT (SENSE)
U502		5080-2150	IC Prgmd-GAL
U503		1826-1370	IC 365 Comp
U504		5080-2250	IC Secondary uP
U505		1826-1369	IC Volt Reg
U506		1826-0346	IC Op Amp
U507		1826-2187	IC DAC
U508		1826-1896	IC Linear Amp
U509		1826-2187	IC DAC
U510		1826-1896	IC Linear Amp
U511		1826-2187	IC DAC
U512		1826-1896	IC Linear Amp
U513		1826-1370	IC 365 Comp
U600		5060-3321	HS Assy (includes 1826-0106)
U601		5060-3320	HS Assy (includes 1826-0122)
U602		5060-3229	HS Assy (includes 1826-0124)
U603		1826-0962	IC Comp 412
U605		1826-2252	IC OP270GP
U606		1826-0962	IC Comp 412
U607		1826-1533	IC 34072
U608		1826-1370	IC 365 COMP
U609, 610		1826-0962	IC Comp 412
U700		1990-0543	IC Opto-Isolator
U720		1826-0468	IC MC3423P1
U721		1858-0047	IC Transistor Array
U740		1858-0076	IC Transistor Array
U74	65/6651A, 65/6655A	1858-0077	IC Transistor Array
	65/6652A-65/6654A	1858-0076	IC Transistor Array
VR610, 611		1902-0025	Diode Zener 10V 5%
VR670		1902-0556	Diode Zener 20V 5%
VR720, 721		1902-0947	Diode Zener 3.6V 5%
VR770		1902-0955	Diode Zener 7.5V 5%
VR771		1902-0957	Diode Zener 9.1V 5%
XF450		2110-0642	Fuseholder
Y501		0410-4219	XTAL 11.590 MHz
		0380-1128	Stdf-female (ref D400,404,690,CR700)
		0515-0885	Screw-mach M4 x .7 8m lg (board to bus strip)
		0535-0031	Hex nut with lockwasher (ref J451)
		0570-0647	Stud-std (ref J451)
		1200-0552	Socket, IC 40-cont (ref U504)
HS400,690		1205-0587	Heat sink (65/6652A ref D400,404,690) (65/6653A ref D402, 690) (65/6654A ref D402, CR700/D690)
HS600	65/6651A	1205-0280	Heat sink (ref R657)
	65/6652A-65/6655A		Not used
		2190-0084	Washer, lock (ref HS400,690)
		2680-0232	Screw machine 10-32 0.312 inch lg.
			PHL pan head (ref D400,404,690,CR700)

Table 5-7. Parts List For 500 Watt A1 Main Board for 655xA & 665xA (continued)

Reference Desig.	Applicable Models	Keysight Part No.	Description
		3050-0236	Washer-FL MTLC (ref D400,404,690,CR700)
		3050-0891	Washer-FL MTLC (ref J451)
		4330-0145	Insulator bead glass (Y501)
		3050-0420	Washer-FL MTLC (ref HS400, 690)
		0515-0909	Screw machine M4 x 0.712 mm lg. pan head (ref bus bars to PCB)
		2110-0689	Fuseholder (ref F400-403)

Table 5-8. A2 Isolator Board Replaceable Parts For 654xA & 655xA Only

Ref. Desig.	Keysight Part No.	Description
C800	0160-5422	Capacitor 0.047 μ F 20%
C801	0160-4822	Capacitor 1000pF 5%
C802	0160-4822	Capacitor 1000pF 5%
C803	0180-3167	Capacitor 1000 μ F 25 V
C804	0180-4129	Capacitor 1 μ f 35 V
C805	0160-5422	Capacitor 0.047 μ F 20%
C806	0160-5422	Capacitor 0.047 μ F 20%
D800	1901-0731	Diode power rectifier
D801	1901-0731	Diode power rectifier
D802	1901-0731	Diode power rectifier
D803	1901-0731	Diode power rectifier
F800	2110-0951	Fuse subminiature 5 AT, 125V
J800,801	1251-8184	Receptacle modular phone
J802	1251-4926	Connector test-point header
J803	1251-4245	Connector 2-pin male
R800	0757-0401	Resistor 100 Ω 1% 0.125 W
R801	0698-3155	Resistor 4.64K 1%
R802	0698-3155	Resistor 4.64K 1%
R803	0698-0082	Resistor 464 Ω 1% 0.125 W
R804	0698-0082	Resistor 464 Ω 1% 0.125 W
R805	0698-3155	Resistor 4.64K 1%
R806	0698-3155	Resistor 4.64K 1%
R807	0698-3155	Resistor 4.64K 1%
U800	1990-0543	IC Opto isolator
U801	1990-0444	IC Opto isolator
U802	1990-0444	IC Opto isolator
U803	1820-1201	IC SN74LS08N
U804	1820-1438	IC SN74LS257N
U805	1826-0122	IC UA7805UC
	5060-2948	Heat sink assembly T-220 (U805)
	1205-0282	Heat sink

Table 5-9A. A2 GPIB Board Replaceable Parts for 664xA & 665xA (surface-mount)

This table applies to units identified on the title page of this manual. Refer to Backdating for additional units

Ref. Desig.	Keysight Part No.	Description
C012-105	0160-6100	Capacitor 1000pF 100V
C106	0180-3975	Capacitor 2.2 μ F 20 V
C107,108	0160-5961	Capacitor 22pF 5% 100 V
C109-110,114, 115,121	0160-6734	Capacitor 0.047 μ F 20%
C122	0180-4606	Capacitor 25V
C123	0160-6497	Capacitor 1000pF 5%
C124	0180-4116	Capacitor 22 μ F 15 V
C125	0160-6734	Capacitor 0.047 μ F 20%
C126,127	0160-5959	Capacitor 33pF 5% 100V
C128	0160-4281	Capacitor 2200pF 20%
C129-134	0160-6734	Capacitor 0.047 μ F 20%
C135	0180-4116	Capacitor 22 μ F 15 V
C136	0160-5955	Capacitor 68pF 5% 100V
C137	0160-6497	Capacitor 0.1 μ F 50V
C138	0160-5945	Capacitor 0.01 μ F 50V
C139-140	0160-6734	Capacitor 0.047 μ F 50V
C141	0180-4116	Capacitor 22 μ F 20V
C142	0160-5950	Capacitor 470pF 50V
D107-110	1901-1335	Diode power rectifier
D111-112	1906-0337	Diode IN4150
D115,116	1901-1332	Diode IN5817
D119,120	1902-1634	Diode zener 18.2V 5%
F101	2110-0699	Fuse subminiature 5AM, 125V
J101	1252-2320	Connector receptacle (GPIB)
J106	1251-4926	Connector receptacle (test header)
J107,108,114,115	1251-7330	Connector receptacle phone
L101	9140-1101	Inductor 470nH
P101	1251-4245	Connector plug 2-pin (ac bias)
Q101	1853-0525	Transistor PNP 2N4917
R103	0699-1391	Resistor 10K 1%
R104	0699-1384	Resistor 4.64K 1%
R105	0699-2682	Resistor 10 M 5%
R106	0699-1360	Resistor 46.4 Ω 1%
R107	0699-1431	Resistor 464 Ω 1%
R108	0699-1415	Resistor 100 Ω 1%
R109	0699-1431	Resistor 464 Ω 1%
R111,114	0699-1384	Resistor 4.64K 1%
R115-117	0699-1360	Resistor 46.4 1%
R118	0699-1318	Resistor 1K 1%
R119	0699-1327	Resistor 1M Ω 1%
R120-122	0699-1384	Resistor 4.64K 1%
R123	0699-1431	Resistor 464 Ω 1%
R130-133	0699-1384	Resistor 4.64K 1%
R134	0699-1432	Resistor 511 Ω 5%
R135,136	0699-1384	Resistor 4.64K 1%
R137	0699-1415	Resistor 100 Ω 1%
R138	0699-1432	Resistor 511 Ω 5%
R139,142	0699-1384	Resistor 4.64K 1%
R143	0699-1330	Resistor 100K 1%
R144	0699-1415	Resistor 100 Ω 1%

Table 5-9A. A2 GPIB Board Replaceable Parts for 664xA & 665xA Only (continued)

Ref. Desig.	Keysight Part No.	Description
TB101	0360-2312	Terminal block (digital control)
U101	1826-2801	IC MC3423PI
U106	5080-2273	IC ROM GPIB
U108	1818-4859	IC MCM 6164C55
U109	1820-5548	IC interface
U110,111	1990-0444	IC Opto isolator
U112	1820-7680	IC 68B50
U113	1990-0543	IC Opto isolator
U114	1820-6721	IC MPU
U115	1820-6176	IC GPIB transceiver
U116	1820-4264	IC SN74ALS573BN
U117	1820-2549	IC 8291A
U118	1820-4185	IC interface
U119	5080-2274	IC GAL programmed GPIB
U120	5080-2275	IC GAL programmed GPIB
U121	1820-0430	IC LM309K
U122	1820-6814	IC GPIB chip
VR101	1902-1634	Diode zener 18.2V 5%
VR102	1902-1802	Diode zener 11V 5%
VR103,104	1902-1609	Diode zener 6.19V 5%
W101	1258-0209	Jumper
Y101	0410-4055	Crystal oscillator 12.000 MHz
	1205-0758	Heatsink (U121)
	0340-1277	Insulator (Y101)
	0535-0031	Nut hex w/lockwasher (J101)
	0515-0642	Screw M 3.5 x 0.6 8 mm lg. pan head (U121)
	0515-0911	Screw M 3 x 0.5 12 mm lg. pan head (J101)

Table 5-9B. A2 GPIB Board Replaceable Parts for 664xA & 665xA (through-hole)

Refer to Backdating for units to which this board applies

Ref. Desig.	Keysight Part No.	Description
C102-105	0160-4822	Capacitor 1000pF 5%
C106	0180-0155	Capacitor 2.2µF 20 V
C107,108	0160-4787	Capacitor 22pF 5% 100 V
C109-111,114, 115,121	0160-5422	Capacitor 0.047µF 20%
C122	0180-3325	Capacitor 25V
C123	0160-4822	Capacitor 1000pF 5%
C124	0180-0228	Capacitor 22µF 15 V
C125	0160-5422	Capacitor 0.047µF 20%
C126,127	0160-4807	Capacitor 33pF 5% 100V
C128	0160-4281	Capacitor 2200pF 20%
C129-134	0160-5422	Capacitor 0.047µF 20%
C135	0180-0228	Capacitor 22µF 15 V
C136	0160-4803	Capacitor 68pF 5% 100V
C138-140	0160-5422	Capacitor 0.047µF 20%
D107-110	1901-0731	Diode power rectifier
D111-114	1901-1098	Diode IN4150
D115,116	1901-1080	Diode IN5817
D119,120	1902-0766	Diode zener 18.2V 5%
F101	2110-0699	Fuse subminiature 5AM, 125V
J101	1252-0268	Connector receptacle (GPIB)

Table 5-9B. A2 GPIB Board Replaceable Parts for 664xA & 665xA Only (continued)

Ref. Desig.	Keysight Part No.	Description
J106	1251-4926	Connector receptacle (test header)
J107,108,114,115	1251-7330	Connector receptacle phone
L101	9100-1610	Inductor 150nH 20%
P101	1251-4245	Connector plug 2-pin (ac bias)
Q101	1853-0089	Transistor PNP 2N4917
R103	0757-0442	Resistor 10K 1% 0.125W
R104	0698-3155	Resistor 4.64K 1%
R105	0683-1065	Resistor 10 M 5% 0.25 W
R106	0698-4037	Resistor 46.4Ω 1%
R107	0698-0082	Resistor 464Ω 1% 0.125 W
R108	0757-0401	Resistor 100Ω 1% 0.125 W
R109	0698-0082	Resistor 464Ω 1% 0.125 W
R111,114	0698-3155	Resistor 4.64K 1%
R115-117	0698-4037	Resistor 46.4 1%
R118	0757-0280	Resistor 1K 1% 0.125 W
R119	0698-8827	Resistor 1MΩ 1% 0.125 W
R120-122	0698-3155	Resistor 4.64K 1%
R123	0698-0082	Resistor 464Ω 1% 0.125 W
R130-133	0698-3155	Resistor 4.64K 1%
R134	0683-1015	Resistor 100Ω 5% 0.25 W
R135,136	0698-3155	Resistor 4.64K 1%
R137	0757-0401	Resistor 100Ω 1% 0.125 W
TB101	0360-2312	Terminal block (digital control)
U101	1826-0468	IC MC3423PI
U106	5080-2152	IC ROM GPIB
U108	1818-4111	IC MCM 6164C55
U109	1820-6789	IC interface
U110,111	1990-0444	IC Opto isolator
U112	1820-3210	IC 68B50
U113	1990-0543	IC Opto isolator
U114	1820-6721	IC MPU
U115	ILH4-0001	IC GPIB transceiver
U116	1820-2724	IC SN74ALS573BN
U117	1820-2549	IC 8291A
U118	1820-4185	IC interface
U119	5080-2153	IC GAL programmed GPIB
U120	5080-2154	IC GAL programmed GPIB
U121	1820-0430	IC LM309K
VR101	1902-0766	Diode zener 18.2V 5%
VR102	1902-0959	Diode zener 11V 5%
VR103,104	1902-0049	Diode zener 6.19V 5%
W101	1258-0209	Jumper
Y101	0410-2109	Crystal oscillator 12.000 MHz
	1205-0758	Heatsink (U121)
	0340-1277	Insulator (Y101)
	0535-0031	Nut hex w/lockwasher (J101)
	0515-0642	Screw M 3.5 x 0.6 8 mm lg. pan head (U121)
	0515-0911	Screw M 3 x 0.5 12 mm lg. pan head (J101)
	1200-0567	Socket IC 28-pin (U106)
	1200-0639	Socket IC 20-pin (U119,120)
	1200-1274	Socket IC (U114)

Table 5-10. A3 Front Panel Board, Replaceable Parts For All Models

Ref. Desig.	Keysight Part No.	Description
C1	0160-5422	Capacitor 0.047 μ F 20%
C2	0160-4808	Capacitor 470pF 5%
C4	0160-4787	Capacitor 22pF 5% 100 V
C5	0180-0155	Capacitor 2.2 μ F 20 V
C6,7	0160-5422	Capacitor 0.047 μ F 20%
C8	0160-4835	Capacitor 0.1 μ F 10% 50 V
C10-12,14-16	0160-5422	Capacitor 0.047 μ F 20%
C17	0180-0155	Capacitor 2.2 μ F 20V
D1,2	1906-0229	Diode array 50V
J2	1251-4927	Receptacle LCD display
J3	1251-4926	Receptacle test header
J4,5	1252-0718	Receptacle (A3G1, A3G2)
J6	1251-8184	Receptacle phone (GPIB board)
L1	9140-0158	Inductor 1 μ H 10%
R1	1810-0560	Resistor network DIP
R2	0698-3359	Resistor 12.7K 1%
R23-25,27-30	0698-3155	Resistor 4.64K 1%
R37	1810-0371	Resistor network SIP
R38	0698-3441	Resistor 215 Ω 1% 0.125 W
R39,40	0698-3155	Resistor 4.64K 1%
RT1	0837-0412	Thermistor
VR16	1902-0950	Diode zener 4.7V 5
U3	1820-6721	IC MPU
U4	5080-2466	ROM programmed front panel
U6	1818-4792	IC memory
U8	1820-2724	IC SN74ALS573BN
W3	1258-0209	Jumper (J3)
W5	0811-3590	Jumper
W19	5080-2261	Cable assembly, LCD Display
	9170-1497	Core shield bead FP Phone cable
	1400-0493	Cable tie REF (1)Core, (2)front phone
Y1	0410-2159	Crystal 10 MHz
	1200-1274	Socket IC (U3)
	1200-1417	Socket IC (U4)
	0340-1277	Insulator (Y1)

Table 5-11. A4A1/A4A3 Left Tunnel Board Parts for 500 Watt 655xA & 665xA Models

Reference Desig.	Applicable Models	Keysight Part No.	Description
C201-204		0160-4801	Capacitor 100pF 5% 100V
C205,206		0160-4835	Capacitor 0.1uF 10% 50V
C207		0160-4801	Capacitor 100pF 5% 100V
C208, 209		0160-6806	Capacitor 0.1uF 400V
C211		0160-4812	Capacitor 220pF 5%
D201		1901-1098	Diode IN4150
F201-204	65/6641A-65/6645A	2110-0671	Fuse .125AM, 125V
F201-204	65/6651A-65/6655A	2110-0716	Fuse .5AM, 125V
F205-207	6651A	2110-0713	Fuse submin 10AM, 125V
	65/6652A-65/6655A	8159-0005	Resistor 0 Ohms
F208		8159-0005	Resistor 0 Ohms
J201		1251-8184	Phone recept (control sigs)
J202		1251-4781	Connector Util (power)
Q201	65/6651A-65/6654A	1854-0989	Transistor NPN SI
	65/6655A	1855-0849	MOSFET- N - Chan
Q202	65/6651A, 65/6652A	5060-3315	Assy (includes FET 1855-0725 and HS)
	65/6653A, 65/6654A	5060-3314	Assy (includes FET 1855-0641 and HS)
	65/6655A		Not used
Q203	65/6651A, 65/6654A	1854-0989	Transistor NPN SI
	65/6655A	1855-0849	MOSFET- N - Chan
Q204	65/6651A-65/6654A	5060-3315	Assy (includes FET 1855-0725 and HS)
	65/6653A, 65/6654A	5060-3314	Assy (includes FET 1855-0641 and HS)
	65/6655A		Not used
Q205	65/6651A-65/6654A	1854-0989	Transistor NPN SI
	65/6655A	1854-1162	Transistor NPN SI
Q206	65/6651A, 65/6652A	5060-3231	Assy (includes XSTR 1853-0497 and HS)
	65/6653A-65/6655A	5060-3250	Assy (includes XSTR 1853-0652 and HS)
Q207	65/6651A-65/6654A	1854-0989	Transistor NPN SI
	65/6655A	1855-0849	MOSFET- N-Chan
Q208	65/6651A, 65/6652A	5060-3315	Assy (includes FET 1855-0725 and HS)
	65/6653A, 65/6654A	5060-3314	Assy (includes FET 1853-0641 and HS)
	65/6655A		Not used
R201	65/6651A, 65/6652A	0811-3849	Resistor .25 5% 3W
	65/6653A	0811-3848	Resistor .39 5% 3W
	65/6654A	0811-3847	Resistor .66 1% 3W
	65/6655A	0811-1220	Resistor 1.5 5% 3W
R202	65/6651A-65/6654A	0698-3430	Resistor 21.5 1%
	65/6655A	8159-0005	Resistor 0 Ohms
R203	65/6651A-65/6654A	0698-3441	Resistor 215 1%
	6655		Not used
R204		0757-0280	Resistor 1K 1% .125W
R205			Not used
R206	65/6651A, 65/6652A	0811-3849	Resistor .25 5% 3W
	65/6653A	0811-3848	Resistor .39 5% 3W
	65/6654A	0811-3487	Resistor .66 1% 3W
	65/6655A	0811-1220	Resistor 1.5 5% 3W
R207	65/6651A-65/6654A	0698-3430	Resistor 21.5 1%
	65/6655A	8159-0005	Resistor 0 Ohms
R208	65/6651A-65/6654A	0698-3441	Resistor 215 1% .125W
	65/6655A		Not used

Table 5-11. A4A1/A4A3 Left Tunnel Board Parts for 500 Watt 655xA & 665xA Models (continued)

Reference Desig.	Applicable Models	Keysight Part No.	Description
R209		0757-0280	Resistor 1K 1% .125W
R210	65/6651A, 65/6652A	0698-8959	Resistor 619K 1%
	65/6653A-65/6655A	0757-0481	Resistor 475K 1%
R211	65/6651A, 65/6652A	0811-3849	Resistor .25 5% 3W
	65/6653A	0811-3848	Resistor .39 5% 3W
	65/6654A	0811-3847	Resistor .66 1% 3W
	65/6655A	0811-1220	Resistor 1.5 5% 3W
R212		0757-0316	Resistor 42.2 1%
R213		0698-3441	Resistor 215 1% .125
R214		0698-0085	Resistor 2.61K 1%
R215	65/6651A-65/6654A	0698-3454	Resistor 215K 1%
	6655	0757-0466	Resistor 110K 1%
R216	65/6651A, 65/6652A	0811-3849	Resistor .25K 5% 3W
	65/6653A	0811-3848	Resistor .39 5% 3W
	65/6654A	0811-3847	Resistor .66 1% 3W
	65/6655A	0811-1220	Resistor 1.5 5% 3W
R217	65/6651A-65/6654A	0698-3430	Resistor 21.5 1%
	65/6655A	8159-0005	Resistor 0 Ohms
R218	65/6651A-65/6654A	0698-3441	Resistor 215 1% .125W
	6655		Not used
R219		0757-0280	Resistor 1K 1% .125W
R220		0698-3454	Resistor 215K 1%
R221		0757-0280	Resistor 1K 1% .125W
R223,224		0683-0475	Resistor 4.7 5% .25W
R225-228	65/6651A	0811-3849	Resistor .25 5% 3W
	65/6652A-65/6655A		Not used
R229, 230, 232	65/6651A-65/6654A		Not used
	65/6655A	0698-3430	Resistor 21.5 1%
U201,202		1826-0962	IC 412 comparator
		1200-1158	Transistor socket (ref Q201 ,203,205,207)
		0340-0458	Insulator (ref Q205)
		0515-0064	Screw-mach M3 x .5 16 m 19 pan head (ref Q201, 203, 205, 207)
		2190-0584	Washer-1k hlcl (ref Q201 ,203,205 ,207)

Table 5-12. A4A2/A4A4 Right Tunnel Board Parts List for 500 Watt 655xA & 665xA Models

Reference Desig.	Applicable Models	Keysight Part No.	Description
C301-304		0160 4801	Capacitor 100 pF 5%
C305,306		0160-4835	Capacitor 1uF 10% 50V
C307		0160-4801	Capacitor 100 PF 5%
C309		0160-6806	Capacitor 1uF 400V
F301-303	65/6641A-65/6645A	2110-0671	Fuse .125AM, 125V
F301-303	65/6651A-65/6655A	2110-0716	Fuse .5AM, 125V
F304-307	65/6651A	2110-0713	Fuse 10AM, 125V
	65/6652A-65/6655A	8159-0005	Resistor 0 Ohms
J300		1251-4245	Conn 2-pin (ref therm assy RT301)
J301		1251-8184	Phone recept (control)
J302		1251-4781	Conn Util (power)
Q301	65/6651A-65/6654A	1854-0989	Transistor NPN SI
	6655	1855-0840	MOSFET-N-Chan
Q302	65/6651A, 65/6652A	5060-3315	Assy (includes FET 1855-0725 and HS)
	65/6653A, 65/6654A	5060-3314	Assy (includes FET 1855-0641 and HS)
	6655		Not used
Q303	65/6651A-65/6654A	1854-0989	Transistor NPN SI
	65/6655A	1855-0840	MOSFET- N-Chan
Q304	65/6651A, 65/6652A	5060-3315	Assy (includes FET 1855-0725 and HS)
	65/6653A,65/6654A	5060-3314	Assy (includes FET 1855-0641 and HS)
	65/6655A		Not used
Q305	65/6651A-65/6654A	1854-0989	Transistor NPN SI
	6655	1855-0840	MOS-N-Chan
Q306	65/6651A, 65/6652A	5060-3315	Assy (includes FET 1855-0725 and HS)
	65/6653A, 65/6654A	5060-3314	Assy (includes FET 1855-0641 and HS)
	6655		Not used
Q307	65/6651A-65/6654A	1854-0989	Transistor NPN SI
	65/6655A	1855-0840	MOSFET- N-Chan
Q308	65/6651A, 65/6652A	5060-3315	Assy (includes FET 1855-0725 and HS)
	65/6653A, 65/6654A	5060-3314	Assy (includes FET 1855-0641 and HS)
	65/6655A		Not used
R301	65/6651A, 65/6652A	0811-3849	Resistor .25 5% 3W
	65/6653A	0811-3848	Resistor .39 5% 3W
	65/6654A	0811-3847	Resistor .66 1% 3W
	65/6655A	0811-1220	Resistor 1.5 5% 3W
R302	65/6651A-65/6654A	0698-3430	Resistor 21.5 1%
	65/6655A	8159-0005	Resistor 0 Ohms
R303	65/6651A-65/6654A	0698-3441	Resistor 215 1% .125W
	65/6655A		Not used
R304		0757-0280	Resistor 1k 1% .125W
R305	65/6651A-65/6653A		Not used
	65/6654A, 65/6655A	0698-3459	Resistor 383K 1%
R306	65/6651A, 65/6652A	0811-3849	Resistor 0.25 5% 3W
	65/6653A	0811-3848	Resistor 0.39 5% 3W
	65/6654A	0811-3847	Resistor 0.661% 3W
	65/6655A	0811-1220	Resistor 1.5 5% 3W
R307	65/6651A-65/6654A	0698-3430	Resistor 21.5 1%
	65/6655A	8159-0005	Resistor 0 Ohms
R308	65/6651A-65/6654A	0698-3441	Resistor 215 1% .125W
	65/6655A		Not used

Table 5-12. A4A2/A4A4 Right Tunnel Board Parts List for 500 Watt 655xA & 665xA Models (continued)

Reference Desig.	Applicable Models	Keysight Part No.	Description
R309		0757-0280	Resistor 1K 1% .125W
R310	65/6651A, 65/6652A, 65/6653A	0698-3454	Resistor 215K 1%
R311	65/6654A, 65/6655A	0757-0470	Resistor 162K 1%
	65/6651A, 65/6652A	0811-3849	Resistor 0.25 5% 3W
	6653	0811-3848	Resistor 0.39 5% 3W
	6654	0811-3847	Resistor 0.66 1% 3W
	6655	0811-1220	Resistor 1.5 5% 3W
R312	65/6651A-65/6654A	0698-3430	Resistor 21.5 1%
	65/6655A	8159-0005	Resistor 0 Ohms
R313	65/6651A-65/6654A	0698-3441	Resistor 215 1% .125W
	6655		Not used
R314		0757-0280	Resistor 1K 1% .125W
R315	65/6651A, 65/6652A, 65/6654A, 65/6655A	0757-0465	
R316	65/6651A, 65/6652A	0757-0470	Resistor 162K 1%
	6653	0811-3849	Resistor 0.25 5% 3W
	6654	0811-3848	Resistor 0.39 5% 3W
	6655	0811-3847	Resistor 0.66 1% 3W
		0811-1220	Resistor 1.5 5% 3W
R317	65/6651A-65/6654A	0698-3430	Resistor 21.5 1%
	65/6655A	8159-0005	Resistor 0 Ohms
R318	65/6651A-65/6654A	0698-3441	Resistor 215 1% .125W
	6655		Not used
R319		0757-0280	Resistor 1K 1% .125W
R320	65/6651A, 65/6652A, 65/6654A, 65/6655A	0757-0463	Resistor 82.5K 1%
R323		0757-0465	Resistor 100K
R325-328	65/6651A	0683-0475	Resistor 4.7 5% .25W
	6652-55	0811-3849	Resistor 0.25 5% 3W
R329-332	65/6651A-65/6654A		Not used
U301,302	65/6655A	0698-3430	Resistor 21.5 1%
		1826-0962	IC 412
		1200-1158	Transistor socket (ref Q301, 303, 305,307)
		0515-0064	Screw-mach M3 x .5 16mm lg pan head (ref Q301,303, 305, 307)
		2190-0584	Washer-1k (ref Q301, 303, 305, 307)

Diagrams

Introduction

This chapter contains various diagrams for use in troubleshooting and maintaining the Keysight power supplies. Separate diagrams and/or tables are provided to show model differences. For wiring connections to external equipment, refer to the Operating Manual.

Interconnections

Figure 6-1 is the overall interconnection diagram. The location of each circuit board in the supply chassis is given in Chapter 3, Figure 3-1.

AC Input and Transformer Connections

Figure 6-2 shows the AC power distribution and Figure 6-9 shows the transformer connectors and cable connections for the 500 watt models (655xA & 665xA).

Circuit Board Schematics

Table 6-1 describes the signal name abbreviations that appear on the schematics. Each schematic has grid coordinates to help you locate signal origins and destinations. Circuit names and test points are also given. A list of the schematic and assembly drawings in this chapter are listed under "Figures" in the front matter to this manual. Table 6-2 gives general notes that apply to the schematic diagrams. Test point information is summarized in Table 6-3.

Component Location Diagrams

Diagrams showing the location of components and test points on each circuit board are shown on the page opposite the associated schematic(s). The AI Main Board's component location diagram has grid coordinates and a table to help you locate components.

Table 6-1. Signal Name Descriptions

Signal Name	Description
A(0)-A(15)	Address lines
AD(0)-AD(7)	Address/Data bus
ANA(0)-ANA(7)	Analog Signal read back bus
ATN	Attention (GPIB)
BOVPROG	Buffered OV programming
BSTX	Buffered secondary transmit
CC	Constant Current status
CCPROG	Constant current programming
CV	Constant voltage status
CVPROG	Constant voltage programming
D(0)-D(7)	Data lines
D101-D108	Data lines (GPIB)
DAV	Data valid (GPIB)
DFI	Discrete fault indicator
DFI_EN	Discrete fault indicator enable
DP	Down programming
EOI	End or identify (GPIB)
FAN PWM	Fan pulse with modulation
FPRX	Front panel receive serial data
FPTX	Front panel transmit serial data
GCL	Gross current limit
GPIB*	GPIB chip select
HSRQ	GPIB service request
IFC	Interface clear (GPIB)
IMON	Current monitor
IPROG	Current programming
ISRQ	Interface service request
KO(0)-KO(5)	Keypad output data bus
KI(0)-KI(5)	Keypad input data bus
MSRQ	Microprocessor service request
NDAC	Not data accepted (GPIB)
NEG IMON	Negative current monitor
NRFD	Not ready for data (GPIB)
OVCMP	Overvoltage comparator
OVP BIAS	Overvoltage protection bias
OVPROG	Overvoltage programming
OVSCR	Overvoltage SCR (crowbar)
OUT INB	Inboard side of current monitoring resistor (power lead)
PCLR	Primary power clear
PREN	Primary remote enable
PRX	Primary receive serial data
PTX	Primary transmit serial data
RAM*	Random access memory chip select
RD*	Read
RDY	Ready
REN	Remote enable
RI	Remote inhibit
RMINB	Inboard side of monitor resistor (sense lead)
RMOUTB	Outboard side of monitor resistor (sense lead)

Table 6-1. Signal Name Descriptions (continued)

Signal Name	Description
ROM*	Read only memory chip select
SPCLR	Secondary power clear
SRQ	Service request (GPIB)
SRX	Secondary receive serial data
STX	Secondary transmit serial data
THERM AMB	Ambient temperature
THERM HS	Heat sink temperature
UART*	Universal asynchronous receive/transmit chip select signal
VMON	Voltage monitor
VOS	Voltage offset
VPROG	Voltage programming
WR*	Write
15 ISUP	15 volt supply is up (has stabilized)

Test Points

Table 6-3 lists the test points that appear on the schematic and component location diagrams. The table includes the test point (e.g., **35**), the circuit point (AIU608-15), and the signal name (CV). The "Measurement and Conditions" column gives signal measurements and the conditions (e.g., operating mode) required to obtain the measurement. Where measurements differ, the applicable models are specified in the table. The following table list summary information about notes appearing in schematic diagrams.

Table 6-2. General Schematic Notes:

1. All resistors are in ohms +1% 1/8 W, unless otherwise specified.		
2. All capacitors are in microfarads unless otherwise specified.		
3. Signal lines that are terminated by flags continue on other sheets, and may also go to other locations on the same sheet.		
Example: CVPROG (SH.2 8C); "SH.2 8C" indicates the sheet number and the coordinates on that sheet where the CVPROG signal line goes.		
4. Unterminated signal lines go to at least one other location on the same sheet.		
Example: _PRX (3A) where "3A" indicates the coordinates on this schematic sheet where the PRX signal line goes.		
5. Unless otherwise noted, bias connections to integrated-circuit packages are as follows:		
	Common	+ 5V
14-pin packages	pin 7	pin 14
16-pin packages	pin 8	pin 16
20-pin packages	pin 10	pin 20

Table 6-3. Test Points

TEST POINT NUMBER	SIGNAL	MEASUREMENT AND CONDITIONS
A2 GPIB BOARD (FIGURE 6-3)		
Connect meter or scope common to test point ① when taking measurements at test points ② through ⑧ .		
① J106-4	Primary/chassis ground	
② U101-1	+ 5 V primary bias	+ 5V ± 0.2V
③ U101-6	PCLR	Goes high for approximately 40 ms at power on, then goes low.
④ U101-8	PCLR*	Held low for approximately 40 ms at power on, then goes high.
⑤ U110-3	STX	Primary transmit to secondary serial data line. Toggles between 0 and 5V.
⑥ U111-6	SRX	Primary receive from secondary serial data line. Toggles between 0 and 5V.
⑦ U119-4	FPRX	Primary receive from front panel serial data line. Toggles between 0 and 5V.
⑧ U119-18	FPTX	Primary transmit to front panel serial data line. Toggles between 0 and 5V.
A2 ISOLATOR BOARD (FIGURE 6-8)		
Connect meter or scope common to test point ① when taking measurements at test points ② through ⑧ .		
① -C803	Primary/chassis ground	
② +U805-3	+ 5 V primary bias	+ 5V ± 0.2V
③ J800-2	SPCLR* (also called RESET*)	Goes high for approximately 40 ms at power on, then goes low.
④ J801-2	PCLR*	Held low for approximately 40 ms at power on, then goes high.
⑤ J801-4	TxD	Primary transmit to secondary serial data line. Toggles between 0 and 5V.
⑥ J801-3	RxD	Primary receive from secondary serial data line. Toggles between 0 and 5V.
⑦ J800-4	Rx	Primary receive from front panel serial data line. Toggles between 0 and .5V.
⑧ J800-3	BSTx	Primary transmit to front panel serial data line. Toggles between 0 and 5 V.

Table 6-3. Test Points (continued)

AI MAIN BOARD (FIGURE 6-5, Sheets 1-4)		
Connect meter or scope common to test point 9 when taking measurements at test points 10 through 46 .		
9 -C770	Secondary common (Sheet 1)	
10 R605	+ 5V Secondary bias (Sheet 1)	+ 5V ± 0.2V
11 +C604	+ 15V Secondary bias (Sheet 1)	+ 15V ± 0.6V
12 Q770 HS	+ 24V (Sheet 1)	+ 21V to + 27V (1V p-p ripple)
13 R607	- 15V Secondary bias (Sheet 1)	- 15V ± 1V
14 U602-2	- 25V (Sheet 1)	- 22V to - 28V (300mV p-p ripple)
15 U603-3	Fan speed control (Sheet 1)	+ 5 V with no load connected and an ambient temperature of 23°C
16 D606 anode	Fan speed control (Sheet 1)	+ 4 V with no load connected and an ambient temperature of 23°C
17 U720-6	SPCLR (Sheet 2)	Goes high for approximately 40 ms at power on, and then goes low
18 U608-3	Shutdown circuit (Sheet 2)	+ 8.1V
19 U721-16	Shutdown circuit (Sheet 2)	0.7V
20 D674 cath	+ 15 V GATED (Sheet 2)	+ 14.5V
21 D676 anode	- 15 V GATED (Sheet 2)	- 14.5V
22 U505-6	CV/CC DACs ref (Sheet 3)	+ 10V ± 0.05V
23 U506-7	Readback DAC ref (Sheet 3)	- 11.58V ± 0.1V
24 U510-6	CCPROG (Sheet 2,3)	- 8.5V approximately with FS current programmed
25 U508-6	CVPROG (Sheet 2,3)	- 9.5V approximately with FS voltage programmed
The measurements at test points 26 through 39 were taken with full scale voltage and full scale current programmed. The measurements were made first in the CV mode with no load and then in the CC mode with the load set for full scale output voltage and current. If the CC annunciator is not on, set the current to a slightly lower value until it comes on.		
26 U605-7	CC control (Sheet 2)	2.2V in CV mode - .25V (6651-54), - 33V (6655) in CC mode

Table 6-3. Test Points (continued)

27 R659	RMOUT (Sheet 2)	0V in CV mode - .135V (6651A), - .125V (6652A), - .195V (6653), - .18V (6654A), - .112V (6655) in CC mode
28 U605-1	IMON (Sheet 2)	0V in CV mode
29 U609-1	NEG IMON (Sheet 2)	0V in CV mode -9.6V in CC mode
30 U506-1	IMON+ circuit (Sheet 2)	0V in CV mode -6.8V in CC mode
31 U608-14	CC* (Sheet 2)	5V in CV mode 0V in CC mode
32 U606-1	CV control (Sheet 2)	1.15V in CV mode 10V in CC mode
33 U606-7	VMON (Sheet 2)	10V in CV or CC mode (@ FS voltage out)
34 U609-7	CV control (Sheet 2)	- 10V in CV or CC mode
35 U608-15	CV* (Sheet 2)	0V in CV mode 5V in CC mode
36 U607-3	CV or CC control (Sheet 2)	0.03V (6651-54), 0.06V (6655) in CV mode 0.6V in CC mode
37 R686	OUTPUT CONTROL (Sheet 2)	0.03V (6651-54), .06V (6655) in CV mode 0.6V in CC mode
38 U607-7	Gross current limit circuit (Sheet 2)	14V in CV or CC mode
39 R687	DP CONTROL (Sheet 2)	0.13V (6651-54) 0.24V (6655) in CV mode 2.4V in CC mode
40 U502-13	BOVPROG (Sheet 2)	0 to 5V PWM pulses
41 U603-5	OV circuit (Sheet 2)	3.8V (with max OVP programmed)
42 U603-7	OV circuit (Sheet 2)	3.8V (with max OVP programmed)
43 U608-8	OV circuit (Sheet 2)	0.2V with full scale voltage programmed (6651-54) 0.6V with full scale voltage programmed (6655)
44 U608-2	OV circuit (Sheet 2)	5V (no OV conditions)
45 U513-11	THERM HS (Sheet 3)	5V (with no load and cold heat sinks)
46 U513-5	THERM AMB (Sheet 3)	4.5V (with 23°C ambient)

Table 6-3. Test Points (continued)

A4A1/A4A3 LEFT TUNNEL BOARDS (FIGURE 6-6)		
<p>Leave meter or scope common connected to test point 9 when taking measurements at test points 47 through 64. The measurements were taken with full scale voltage and current programmed. The measurements were made first in the CV mode with no load, and then in the CC mode with the load set for full scale voltage and current. Test points are listed for the first regulator (closest to fan) and the last regulator stages only. The number of regulator stages that will be on (conducting) depends upon the output current. In the CV mode with no load connected (no output current), only one or two stages will be on conducting current through the down programmer stages. The remaining regulator stages will be off (not conducting). In the CC mode with the load set for full scale output voltage and current all regulator stages will be on.</p>		
47 U201-3	OUTPUT CONTROL (comparator + input to all stages)	0.03V (6651-54), 0.06 (6655) in CV mode 0.6V in CC mode
48 U201-2	Stage 1 comparator -input	0.03V in CV mode 0.6V in CC mode
49 201-2	Stage 1 FET driver input	4V in CV mode 4.7V in CC mode
50 †Q202-3	Stage 1 reg control	0.6V in CV mode (reg Q201 on) 1.3V in CC mode (reg Q201 on)
51 U202-2	Stage 3 comparator -input	0.065V in CV mode 0.6V in CC mode
52 U202-1	Stage 3 FET driver control	- 12 V in CV mode 4.4 V in CC mode
53 †Q208-3	Stage 3 reg control	0V in CV mode (reg Q207 off) 1.2V in CC mode (reg Q207 on)
54 U202-5	DP CONTROL	0.12V (6651-54), 0.24 (6655) in CV mode 2.4V (6651-54), 2.1 (6655) in CC mode
55 U202-6	DP stage comparator -input	0.12 V (6651-54), 0.24 (6655) in CV mode 2.2 V (6652-54), 0.26 V (6651), 0.3 V (6655) in CC mode
56 U202-7	DP stage comparator output	-1.2V in CV mode 13.6V in CC mode
57 Q206-1	DP stage driver input	-0.6V in CV mode 0.06 V (6652-54), 0.09 V (6651), 0.01 V (6655) in CC mode

Table 6-3. Test Points (continued)

A4A2/A4A4 RIGHT TUNNEL BOARDS (FIGURE 6-7)		
The same measurement conditions apply as were described for the A4A1/A4A3 Left Tunnel Boards.		
58 U301-3	OUTPUT CONTROL	0.03V (6651-54), 0.06 V (6655) in CV mode 0.6V in CC mode
59 U301-2	Stage 1 comparator-input	0.03V (6651-54), 0.06 V (6655) in CV mode 0.06V in CC mode
60 U301-1	Stage 1 FET driver control	4V in CV mode 4.7V in CC mode
61 †Q302-3	Stage 1 reg control	0.6V in CV mode (reg Q301 on) 1.3V in CC mode (reg Q301 on)
62 U302-2	Stage 4 comparator-input	0.17V in CV mode 4.4V in CC mode
63 U302-1	Stage 4 FET driver control	- 12V in CV mode 4.4V in CC mode
64 †Q308-3	Stage 4 reg control	0V in CV mode (reg Q307 off) 1.2V in CC mode (reg Q307 on)

† Models 65/6651-65/6654 only (Not used on 120 V units).

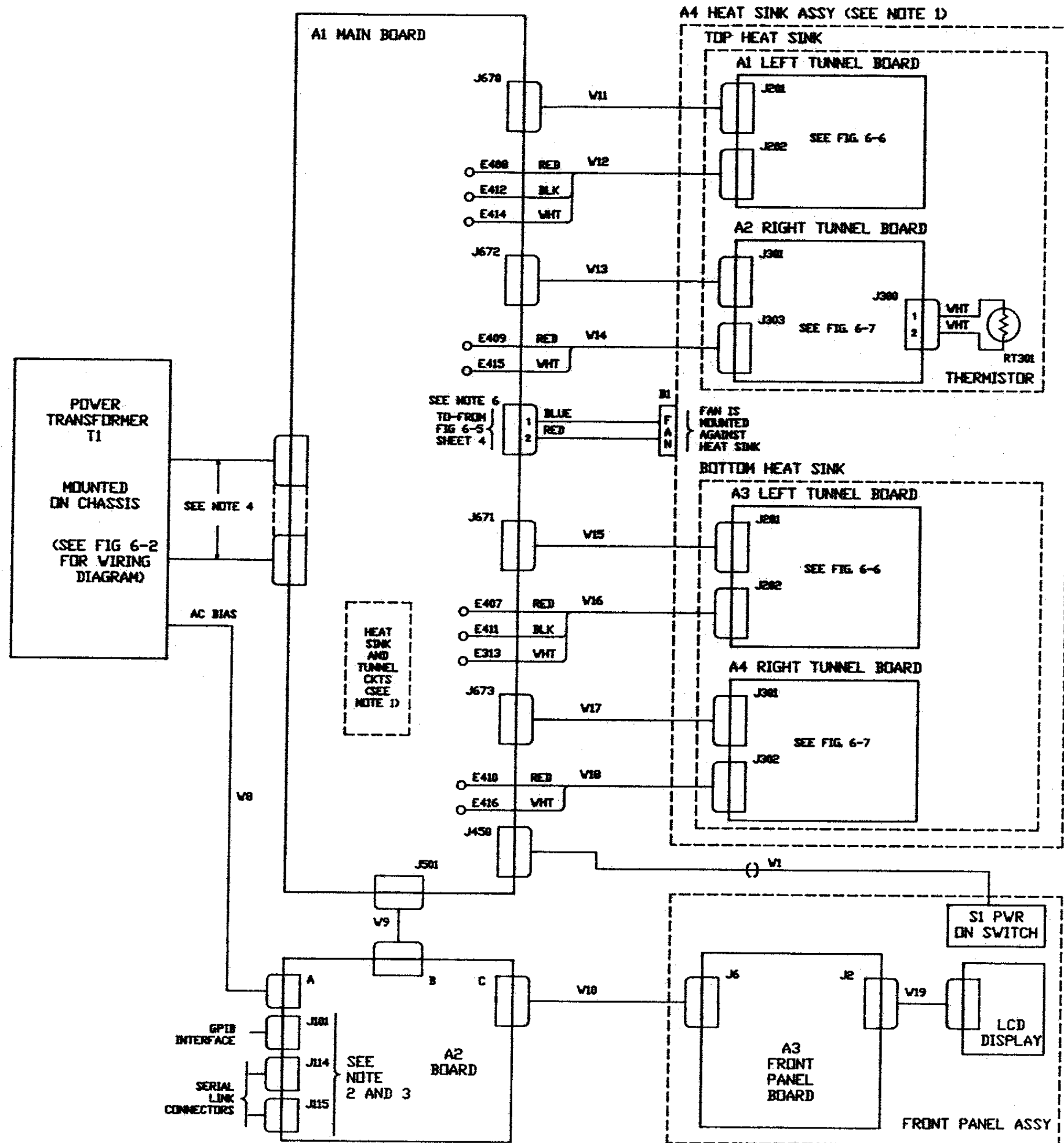

NOTES

1. FOR MODELS 655xA & 665xA (500WATT), THE A4 HEAT SINK ASSY IS EXTERNAL TO THE A1 MAIN BOARD, AS SHOWN IN THIS FIGURE. FOR MODELS 654xA & 664xA (200 WATT), THE HEAT SINK ASSY TOGETHER WITH THE TUNNEL CIRCUITS ARE PART OF THE A1 MAIN BOARD.
2. CONNECTORS J101, J114, J115 SHOWN ON THE A2 BOARD ARE PRESENT ONLY ON THE 664xA & 665xA MODELS (GPIB).
3. CONNECTORS A, B, AND C SHOWN ON THE A2 BOARD HAVE DIFFERENT REFERENCE DESIGNATIONS FOR ANALOG PROGRAMMABLE Vs GPIB MODELS, AS INDICATED IN TABLE 1.

TABLE 1. REFERENCE DESIGNATOR ASSIGNMENTS		
CONNECTOR DESIGNATOR ON A2 BOARD	FOR 664xA & 665xA MODELS, (A2 GPIB BOARD) USE THESE DESIGNATORS	FOR 655xA & 665xA MODELS, (A2 ISOLATOR BORD) USE THESE DESIGNATORS
A	P101	J803
B	J107	J800
C	J108	J801

4. THE INTRAWIRING BETWEEN XFMR T1 AND THE A1 MAIN BOARD VARIES FROM MODEL TO MODEL AS DOES THE NUMBER OF INTERFACING CONNECTORS. REFER TO FIGURE 6-2 TO SEE THE WIRING FOR A PARTICULAR MODEL.
5. V8, V9 AND V10 ARE TELEPHONE CABLES WITH PHONE CONNECTORS ON EITHER END OF CABLE.
6. THIS IS CONNECTOR J601 FOR 655xA & 665xA MODELS AND J602 FOR 654xA & 664xA MODELS.

Figure 6-1. Power Supply Interconnection Diagram for All Models

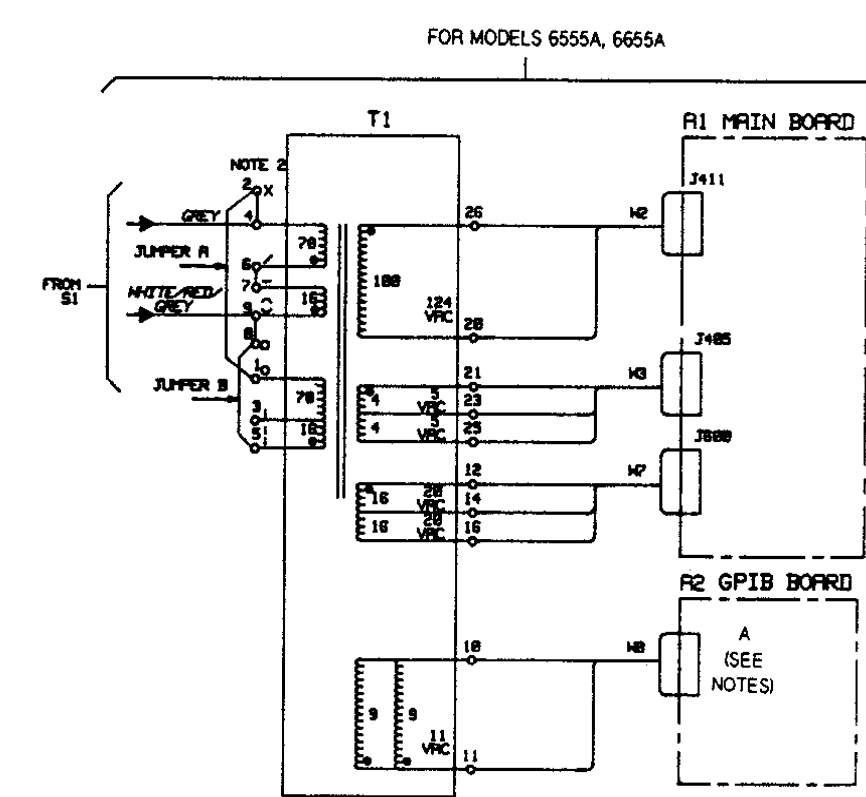
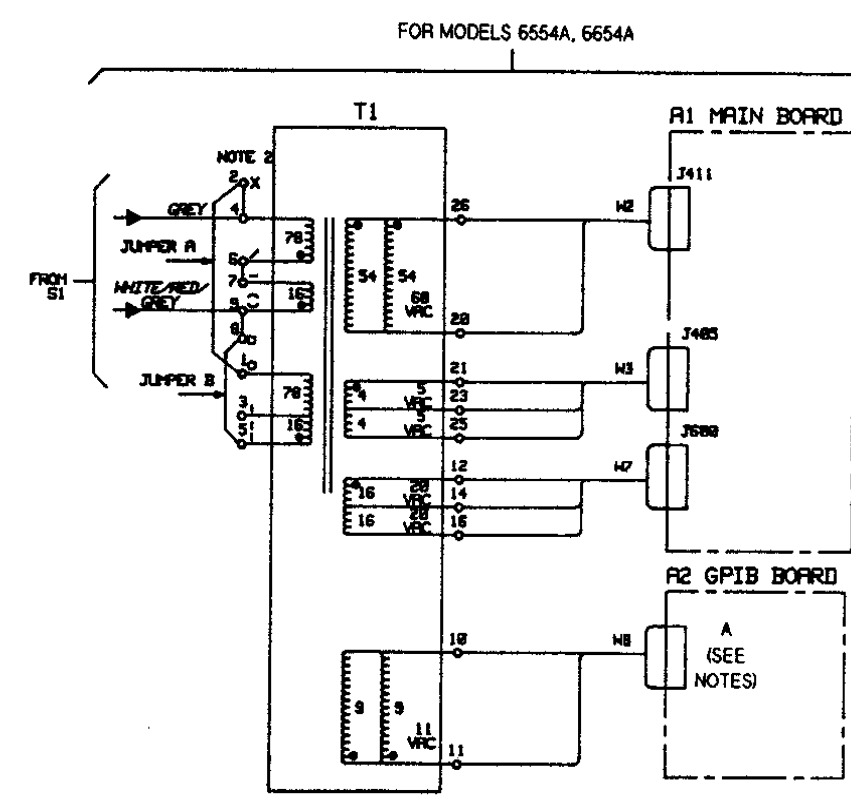
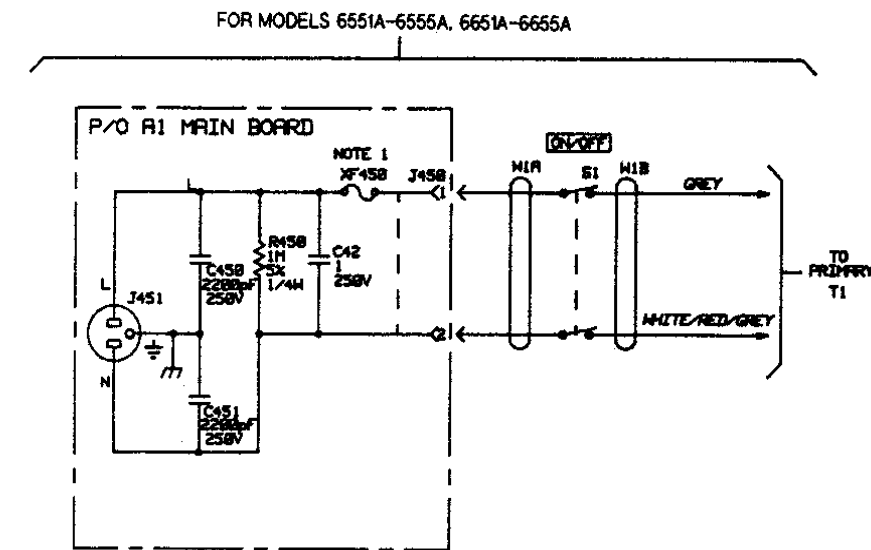
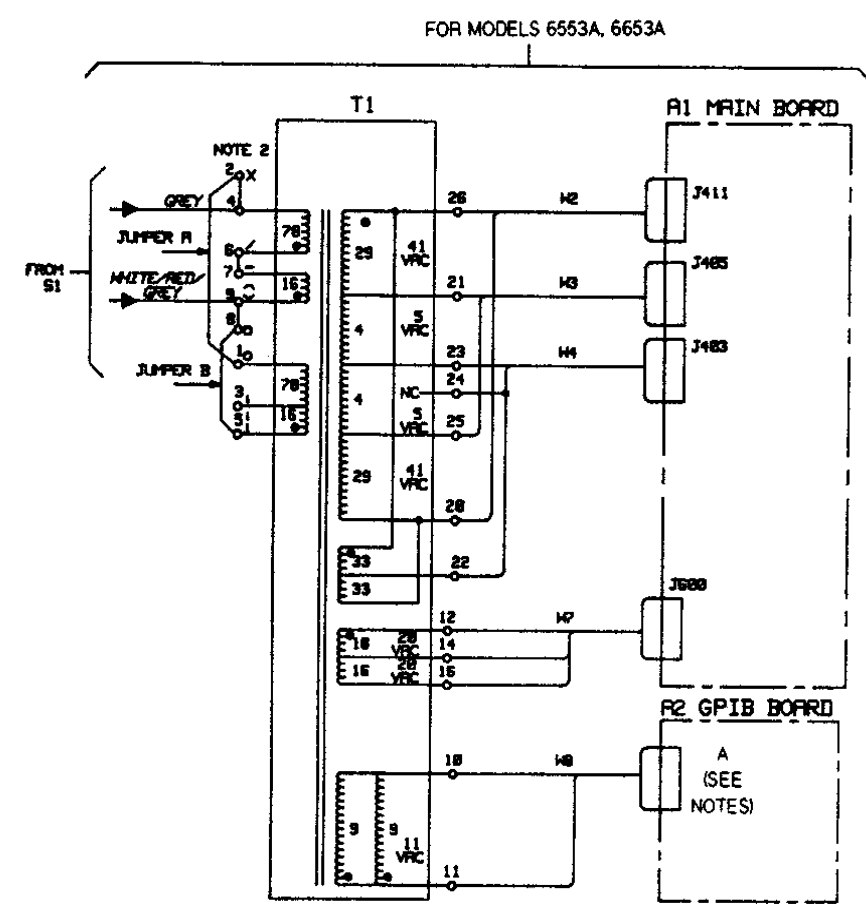
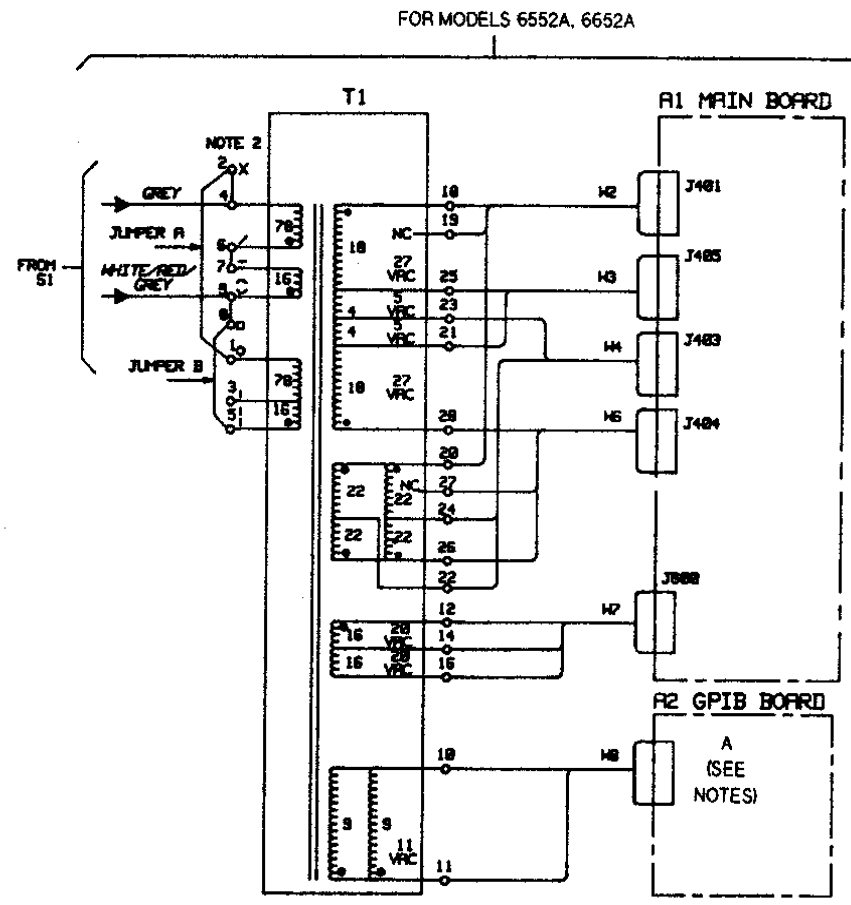
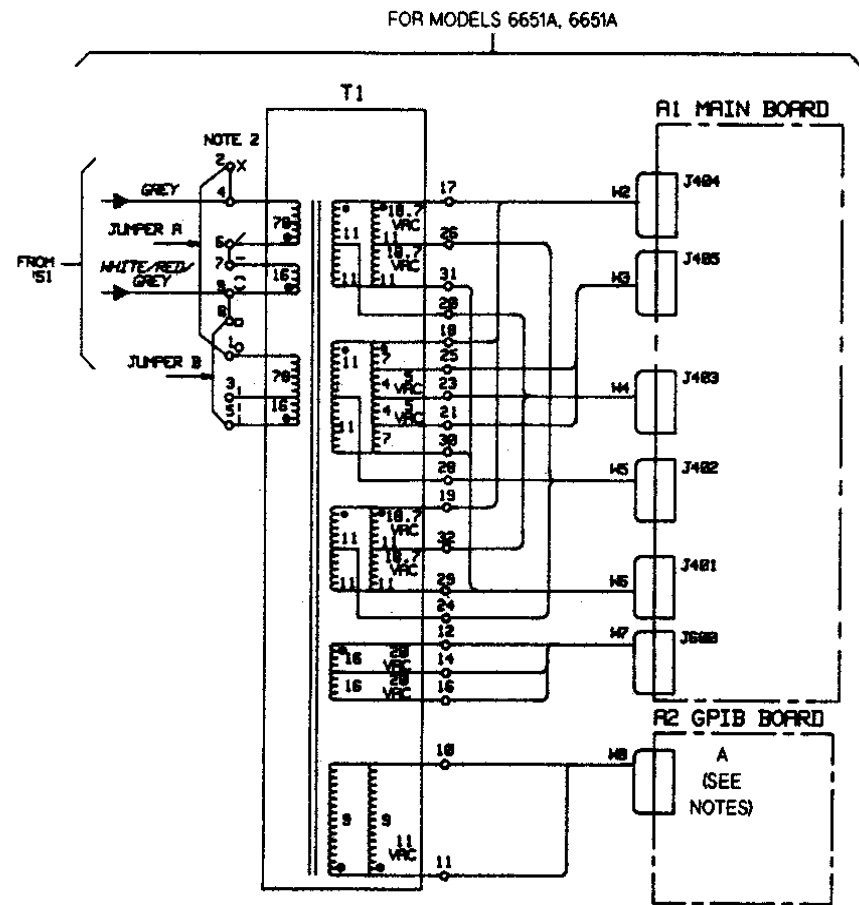

- NOTES:
1. FUSE F450 IS 15A FOR 100VAC INPUT, 12A FOR 120 VAC INPUT, 7A FOR 220/240 VAC INPUT.
 2. T1 IS SHOWN CONNECTED FOR 120 VAC INPUT. JUMPERS A AND B AS WELL AS THE WHITE/RED/GREY WIRE MUST BE CONNECTED ACCORDING TO THE REQUIRED LINE VOLTAGE AS SHOWN BELOW. THE GREY WIRE REMAINS CONNECTED TO T1-4 IN ALL CASES.
- | LINE VOLTAGE | JUMPER A | JUMPER B | WHITE/RED/GREY WIRE |
|--------------|----------------------|----------------------|---------------------|
| 100 VAC | T1-2 (X) TO T1-1 (O) | T1-7 (-) TO T1-3 (O) | T1-6 (U) |
| 120 VAC | T1-2 (X) TO T1-1 (O) | T1-8 (□) TO T1-5 (U) | T1-9 (C) |
| 220 VAC | T1-6 (U) TO T1-7 (-) | T1-8 (□) TO T1-1 (O) | T1-3 (O) |
| 240 VAC | T1-6 (U) TO T1-7 (-) | T1-8 (□) TO T1-1 (O) | T1-5 (U) |

3. THE T1 POWER TRANSFORMER'S TERMINAL LOCATIONS AND CABLE CONNECTIONS ARE SHOWN IN FIGURE 6-9.
4. FOR MODELS 665xA, THE A2 BOARD IS THE GPIB BOARD AND CONNECTOR 'A' IS P101.
5. FOR MODELS 655xA, THE A2 BOARD IS THE ISOLATOR BOARD AND CONNECTOR 'A' IS J803.
6. SEE FIGURE 6-1 FOR INTERCONNECTION WIRING DIAGRAM.

Figure 6-2. AC Power Distribution Diagram for 655xA & 665xA Models

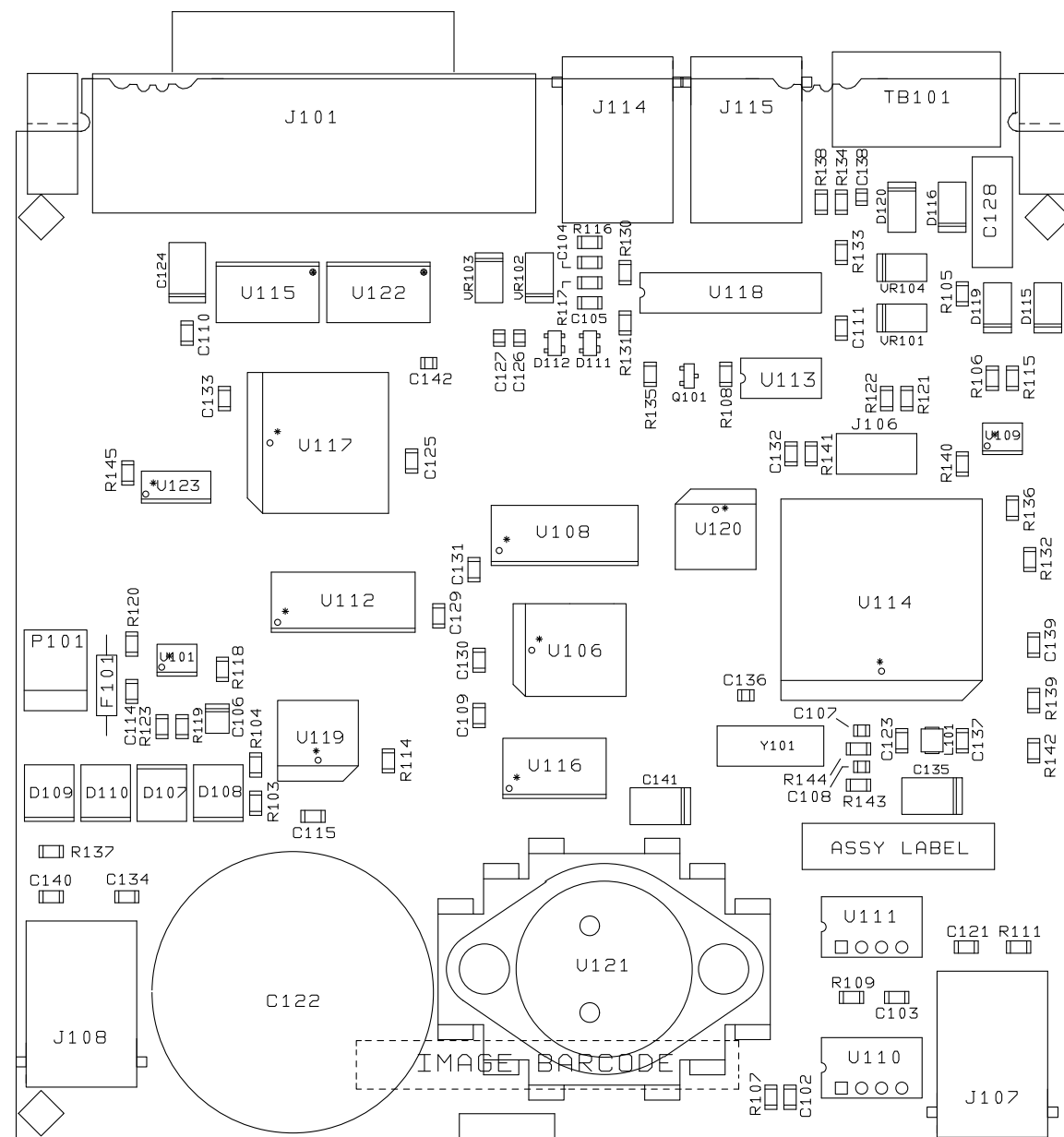

Figure 6-3. GPIB Board Assembly Diagram (sheet 1 of 2)

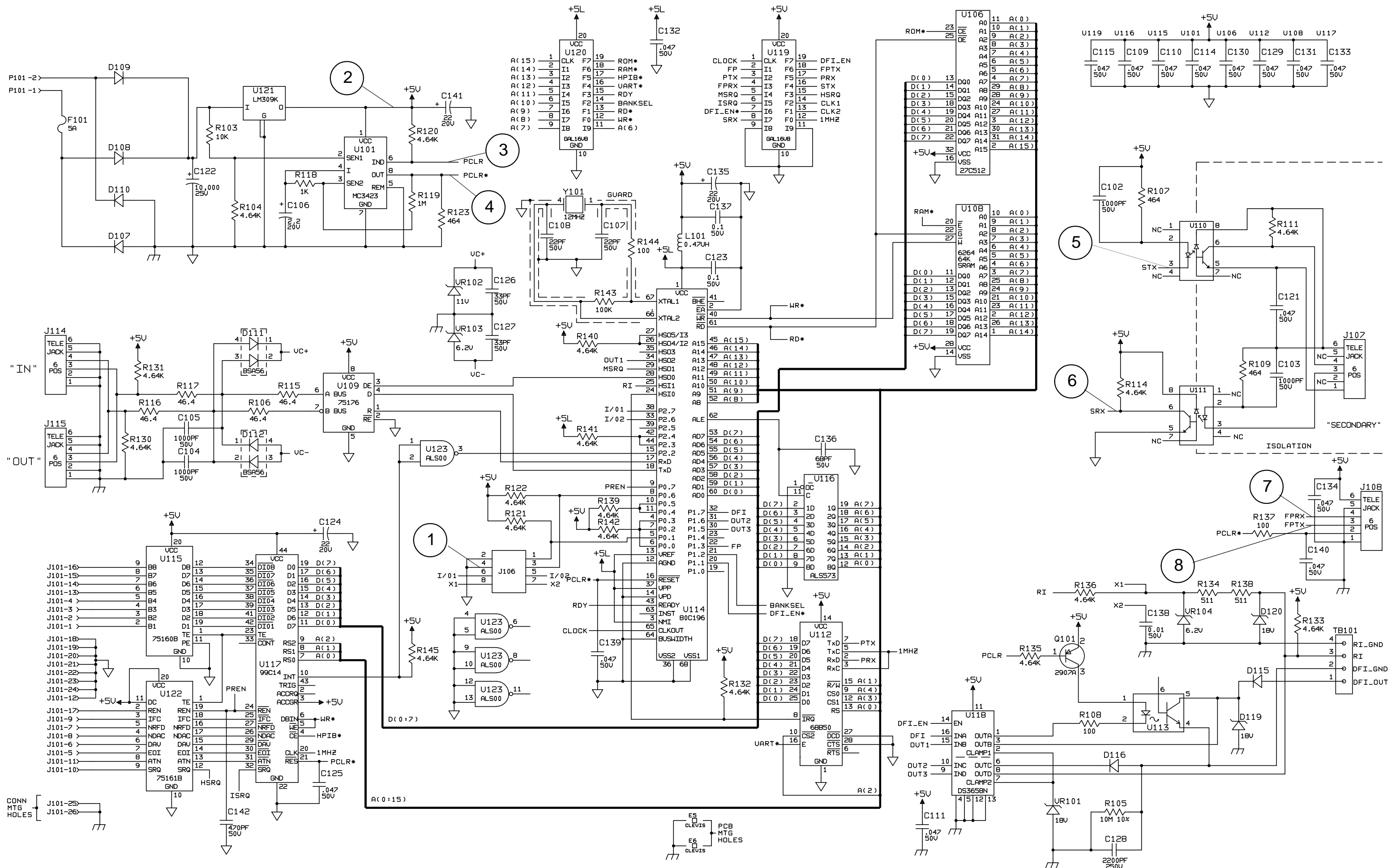

Figure 6-3. GPIB Board Schematic Diagram (sheet 2 of 2)

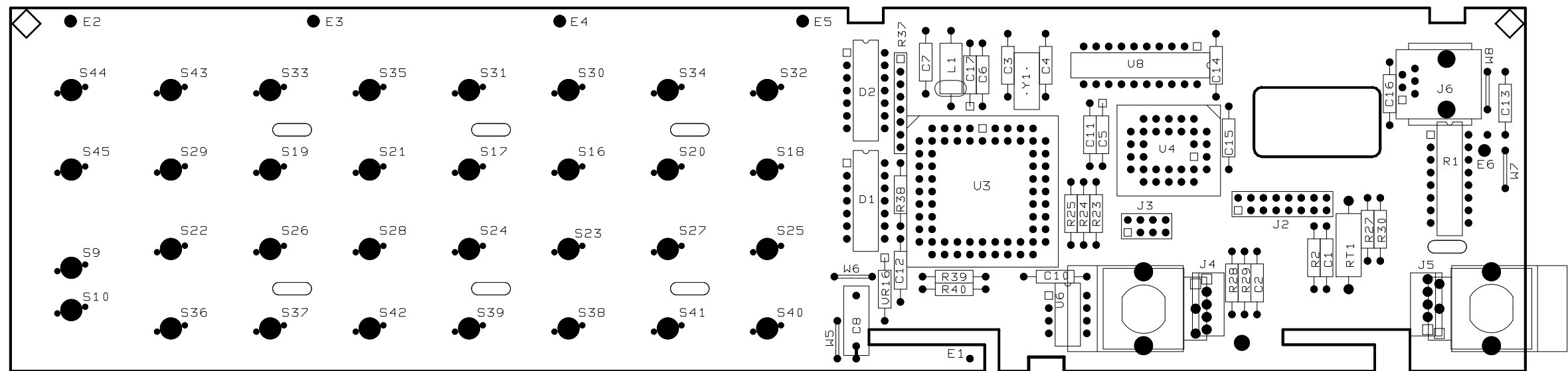
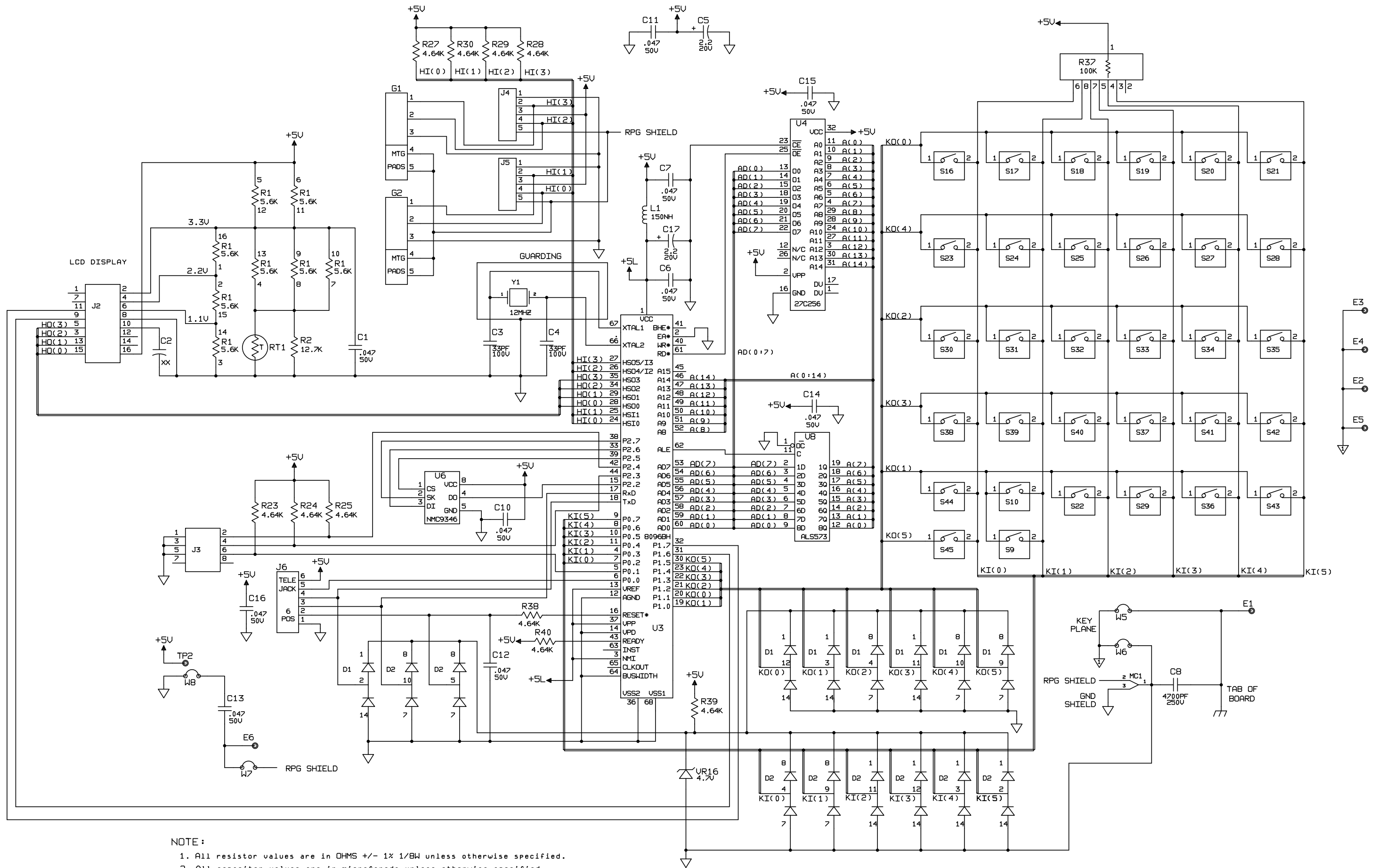

Figure 6-4. Front Panel Board Assembly Diagram (sheet 1 of 2)



NOTE :

1. All resistor values are in OHMS +/- 1% 1/BW unless otherwise specified.
2. All capacitor values are in microfarads unless otherwise specified.

Figure 6-4. Front Panel Board Schematic Diagram (sheet 2 of 2)

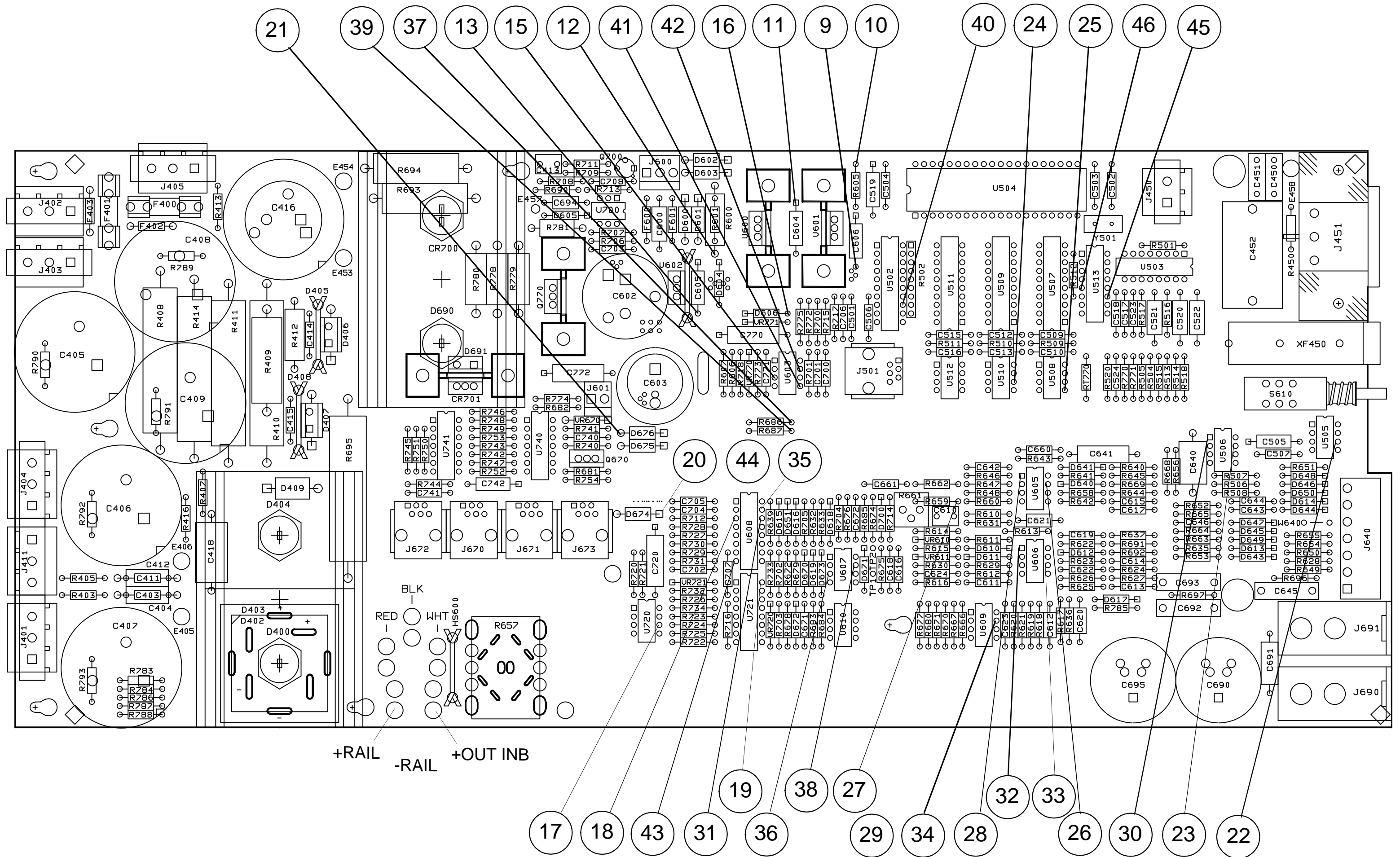

Figure 6-5. A1 Main Board Assembly Diagram and Test Points for 655xA & 665xA Models Only

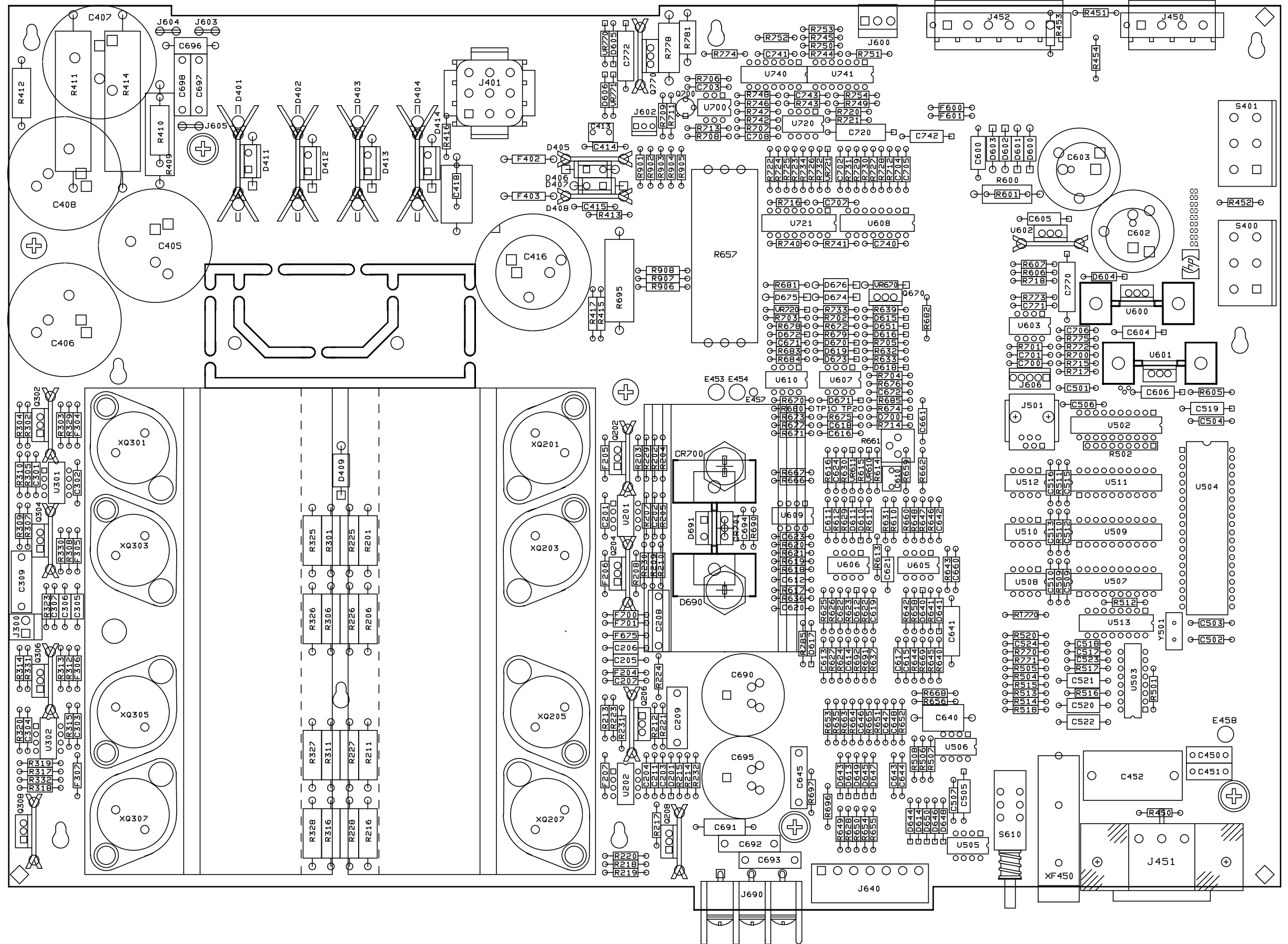

Figure 6-5. A1 Main Board Assembly Diagram for 654xA & 664xA Models Only

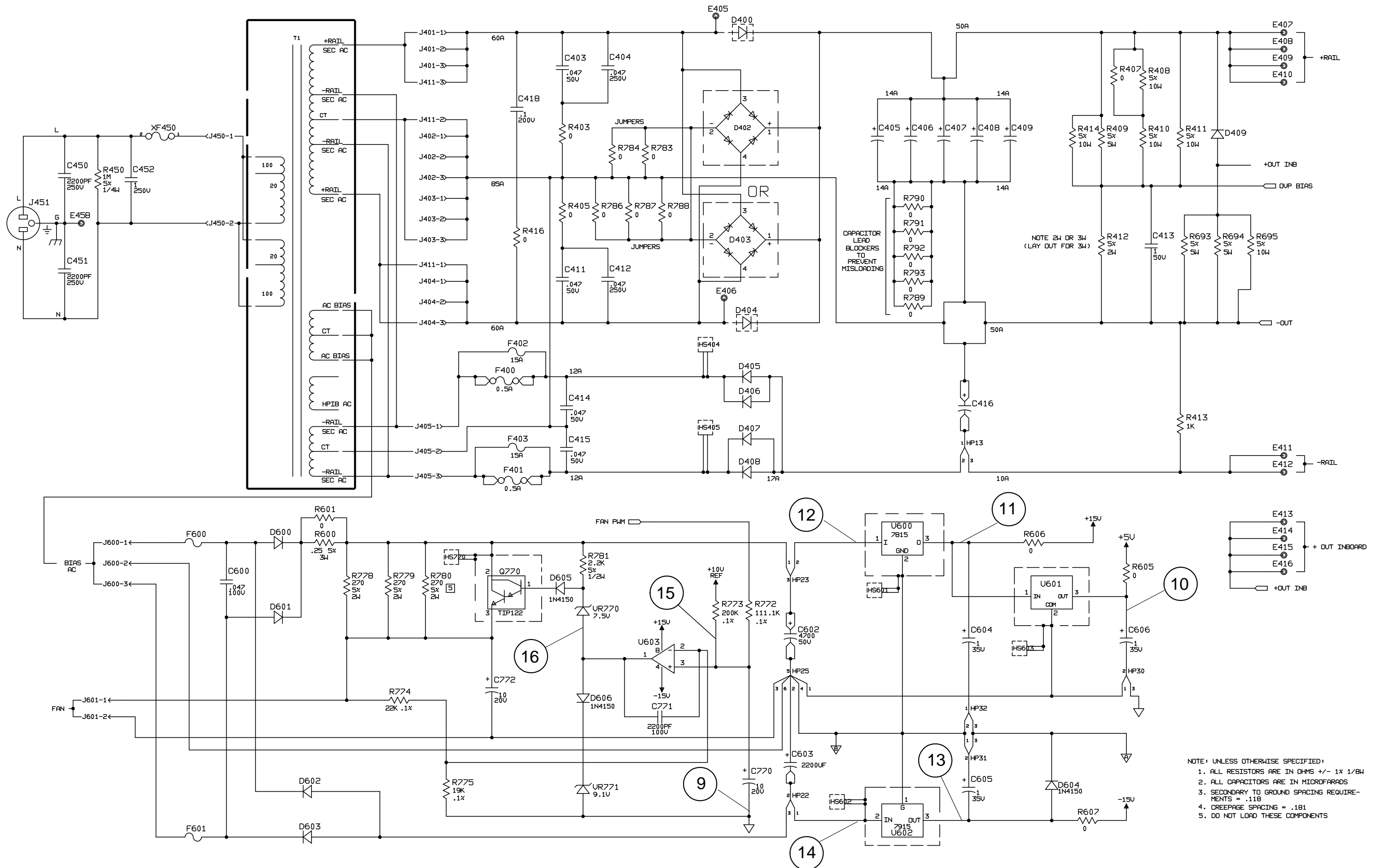

Figure 6-5. A1 Main Board AC Input, Power Rectifier, Bias, and Fan Speed Control Circuits Schematic Diagram for 655xA & 665xA Models Only (sheet 1A)

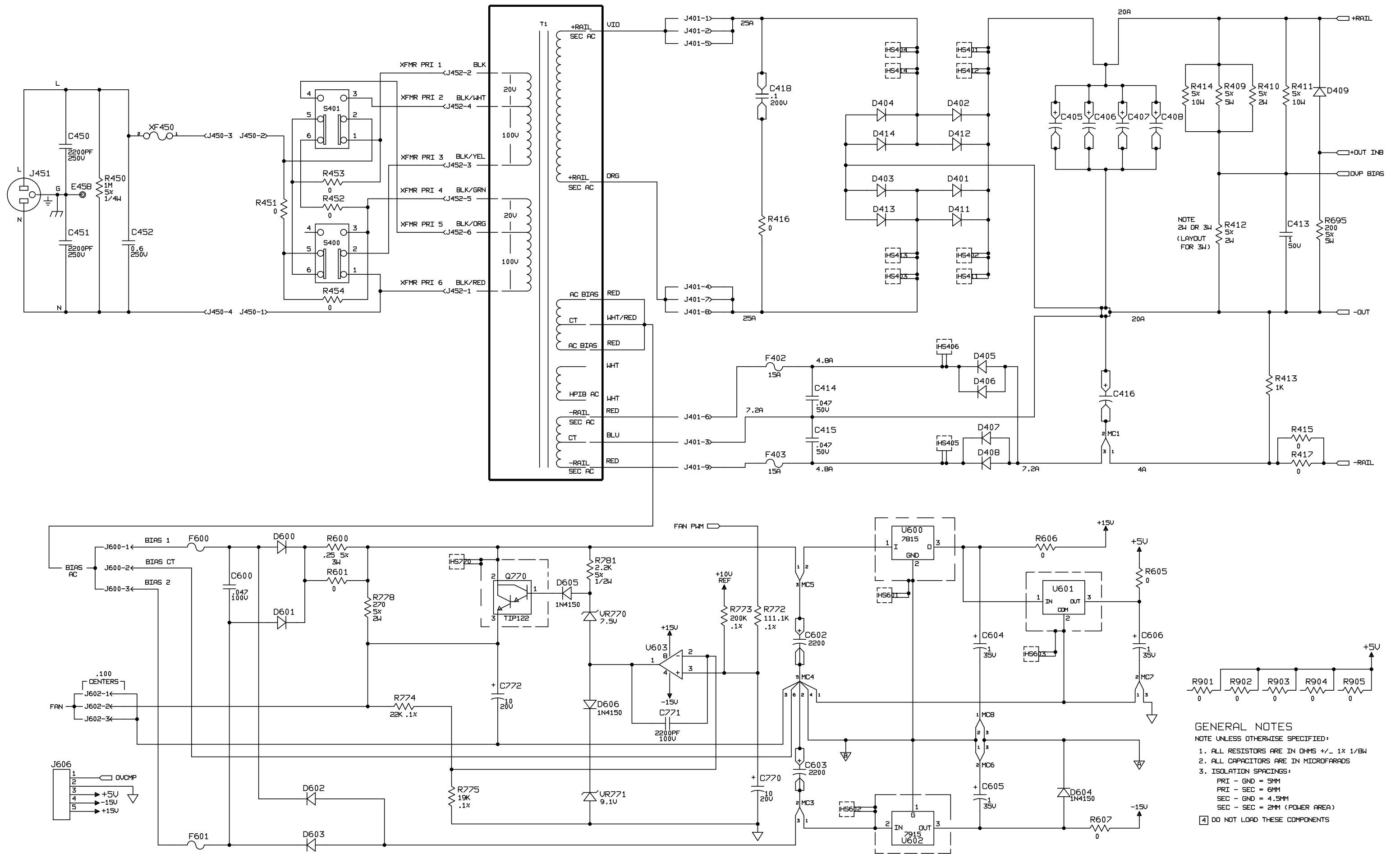

Figure 6-5. A1 Main Board AC Input, Power Rectifier, Bias, and Fan Speed Control Circuits Schematic Diagram for 654xA & 664xA Models Only (sheet 1B)

- GENERAL NOTES**
 NOTE UNLESS OTHERWISE SPECIFIED:
1. ALL RESISTORS ARE IN OHMS +/- 1% 1/8W
 2. ALL CAPACITORS ARE IN MICROFARADS
 3. ISOLATION SPACINGS:
 PRI - GND = 5MM
 PRI - SEC = 6MM
 SEC - GND = 4.5MM
 SEC - SEC = 2MM (POWER AREA)
- [4] DO NOT LOAD THESE COMPONENTS

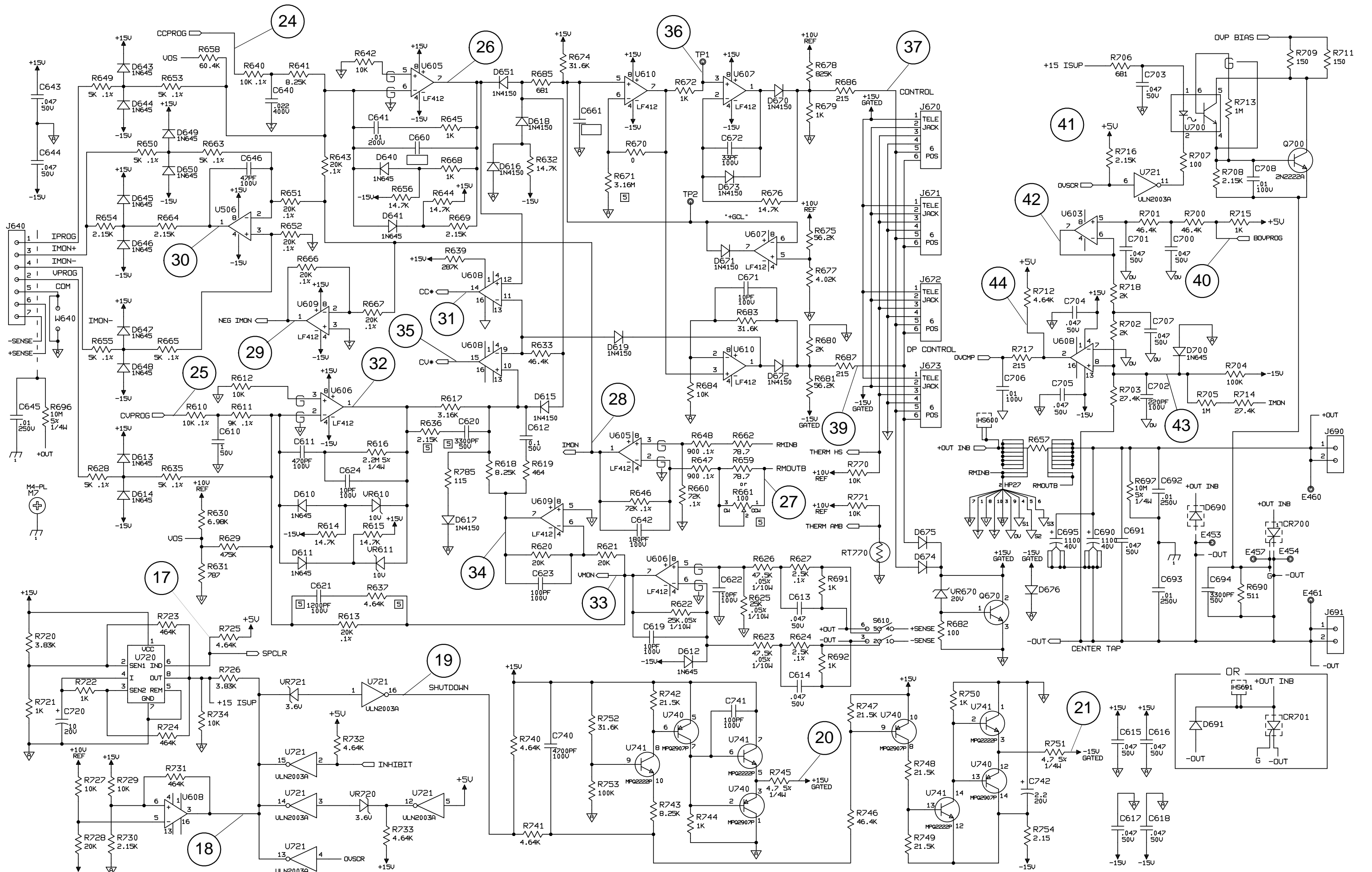

Figure 6-5. A1 Main Board CV/CC Control & Output Bias/Shutdown Circuits Schematic Diagram for 655xA & 665xA Models Only (sheet 2A)

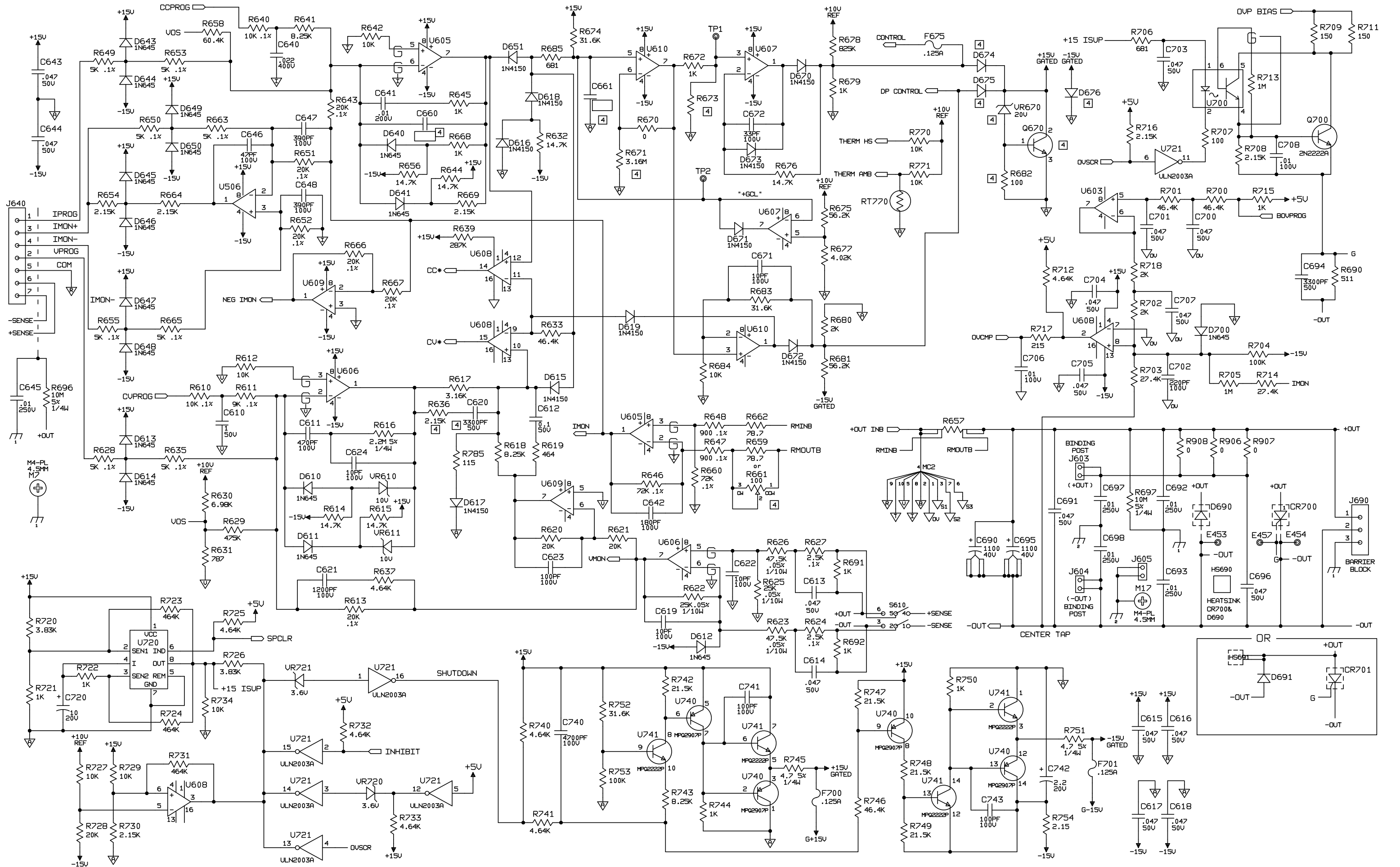

Figure 6-5. A1 Main Board CV/CC Control & Output Bias/Shutdown Circuits Schematic Diagram for 654xA & 664xA Models Only (sheet 2B)

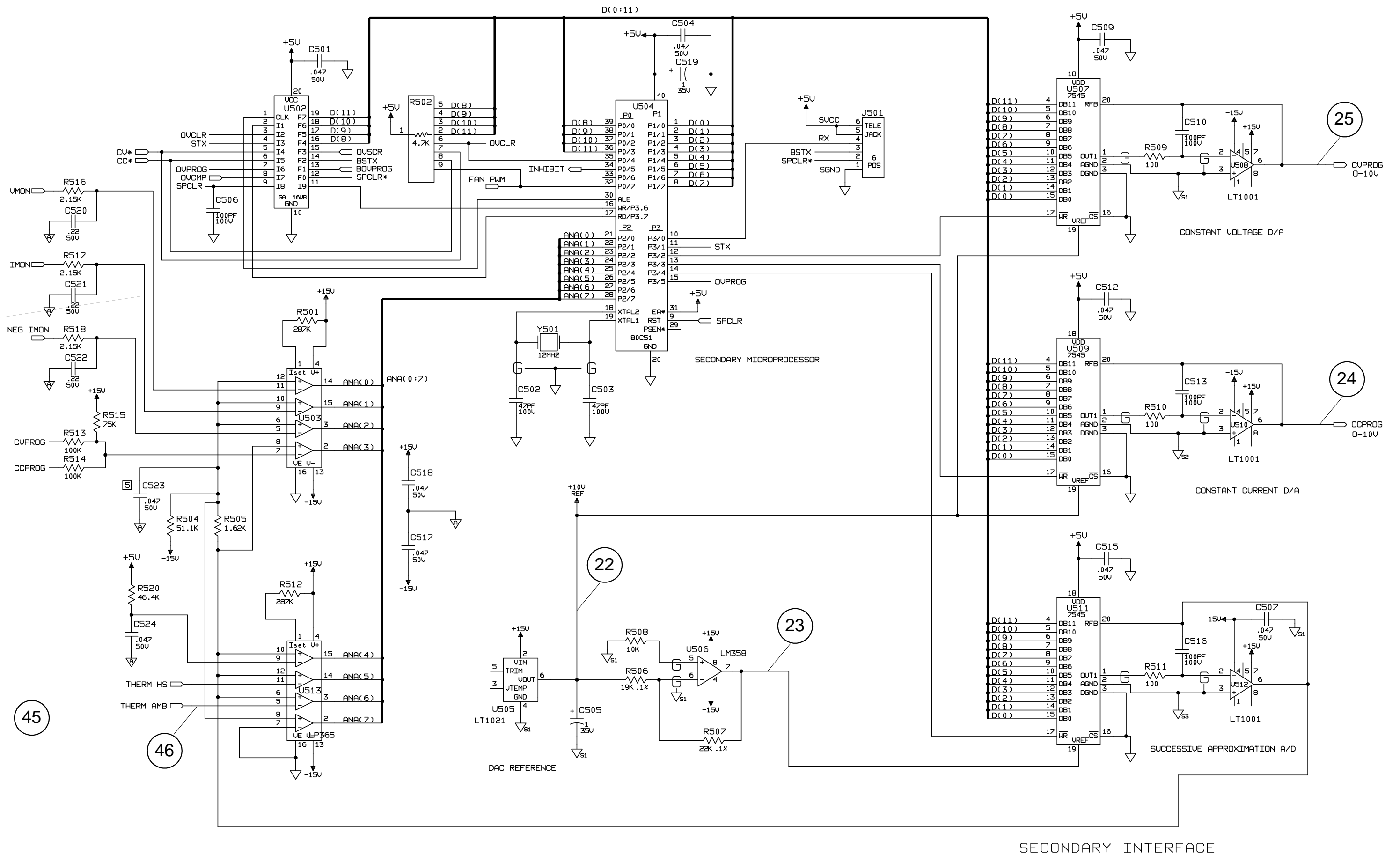

Figure 6-5. A1 Main Board Secondary Interface & CV/CC Readback DACs Schematic Diagram for All Models (sheet 3)

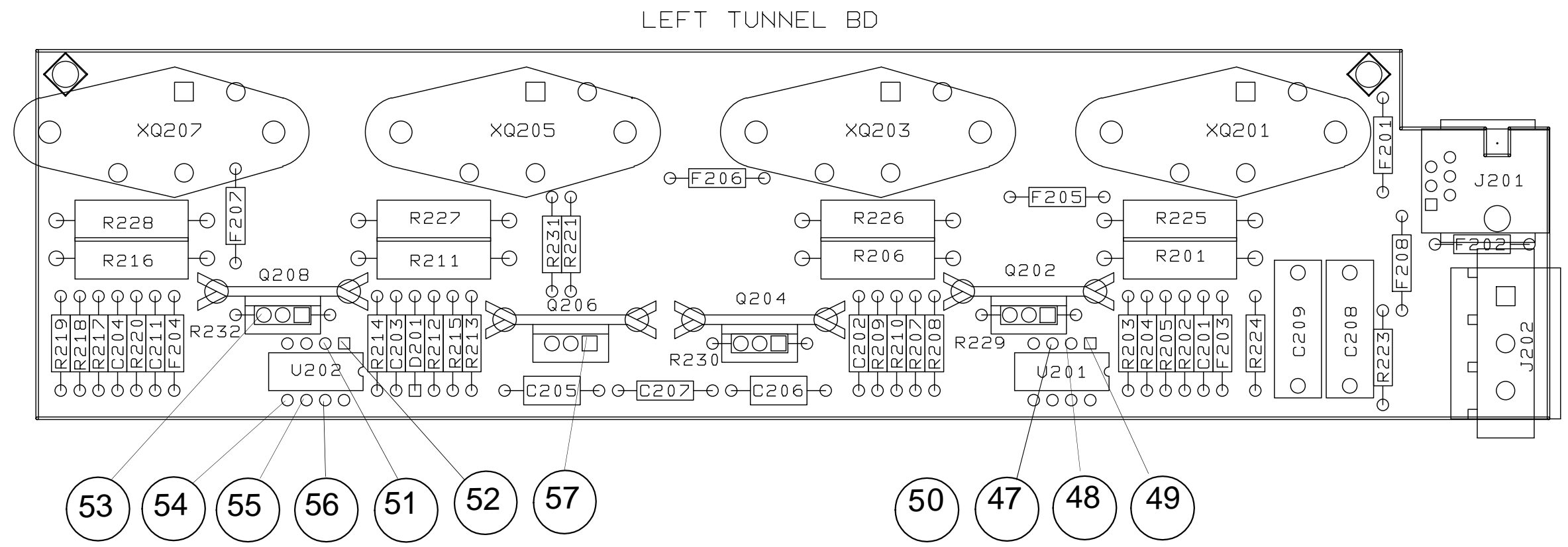
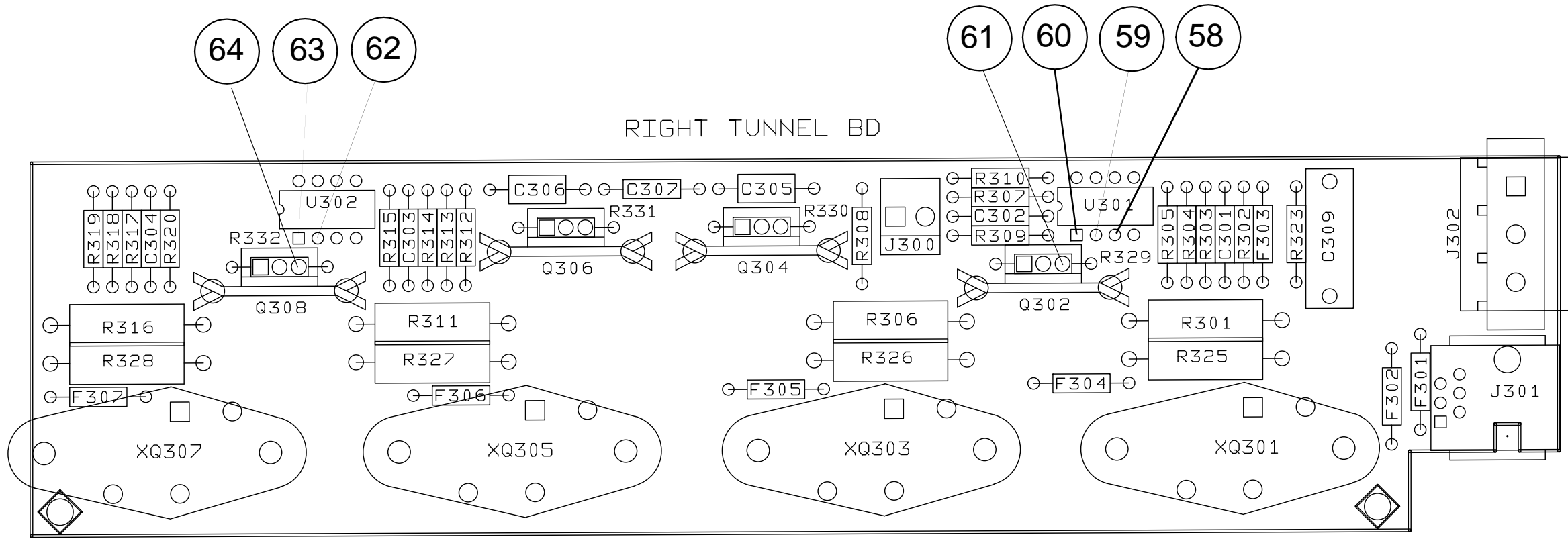
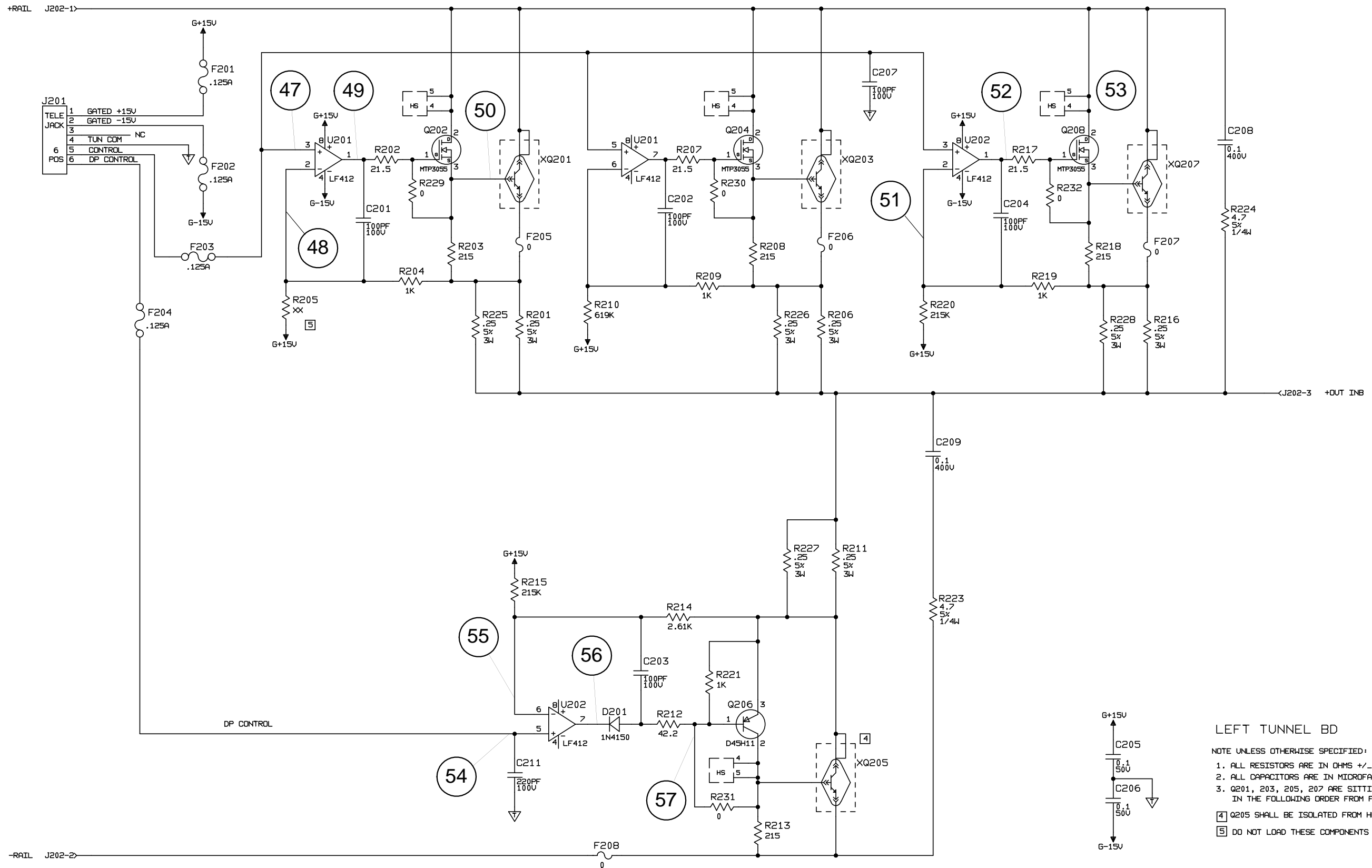

Figure 6-6. Left/Right Tunnel Board Assembly Diagram and Test Points for 655xA & 665xA Models Only



LEFT TUNNEL BD

NOTE UNLESS OTHERWISE SPECIFIED:

1. ALL RESISTORS ARE IN OHMS +/- 1% 1/8W
2. ALL CAPACITORS ARE IN MICROFARADS
3. Q201, 203, 205, 207 ARE SITTING ON SAME HEATSINK IN THE FOLLOWING ORDER FROM FAN: Q201, 203, 205, 207
- 4 Q205 SHALL BE ISOLATED FROM HEATSINK
- 5 DO NOT LOAD THESE COMPONENTS

Figure 6-6. Left Tunnel Circuits Schematic Diagram for 655xA & 665xA Models Only (sheet 1)

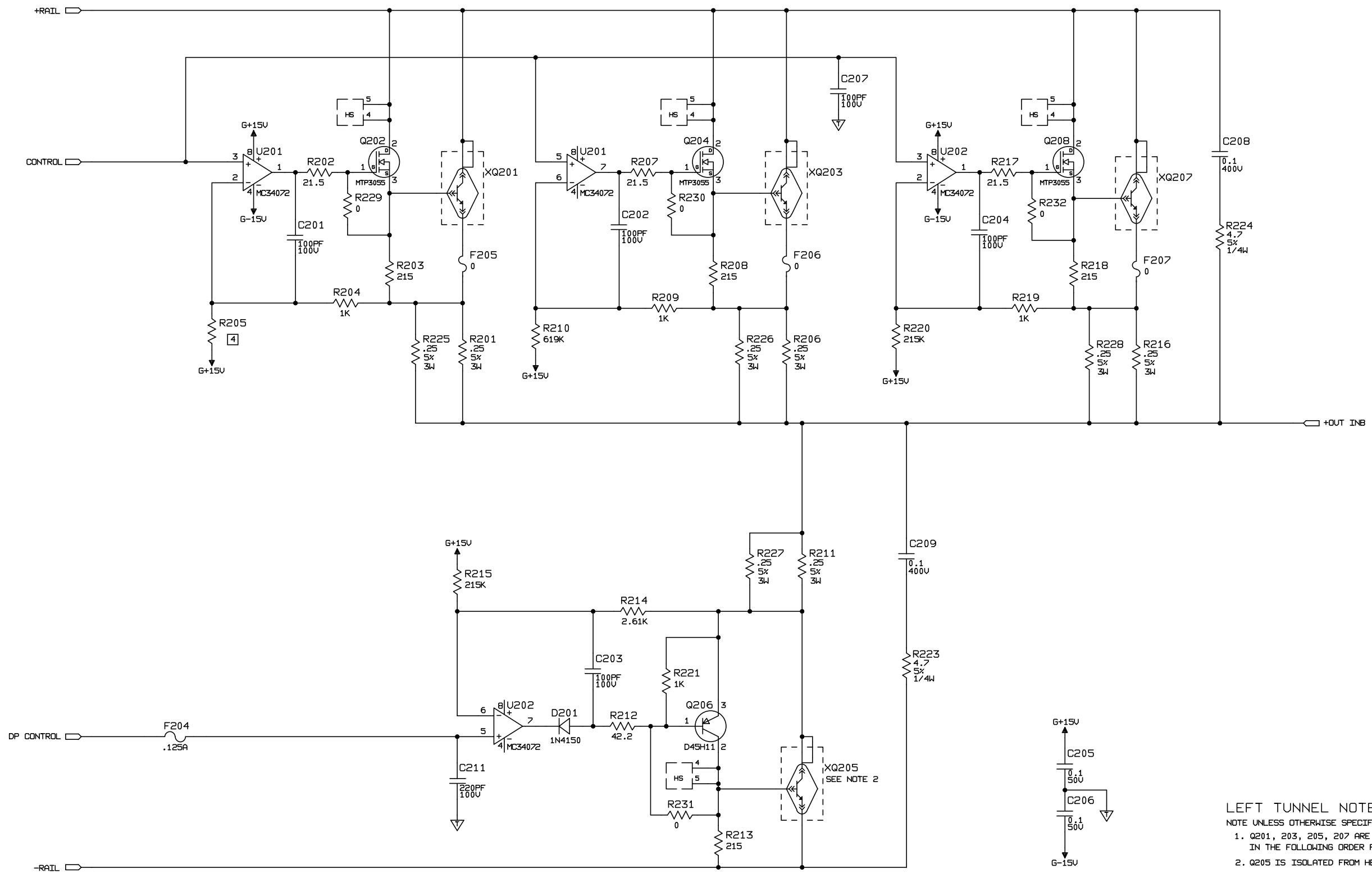

LEFT TUNNEL NOTES
 NOTE UNLESS OTHERWISE SPECIFIED:
 1. Q201, 203, 205, 207 ARE SITTING ON SAME HEATSINK
 IN THE FOLLOWING ORDER FROM FAN: Q201, 203, 205, 207
 2. Q205 IS ISOLATED FROM HEATSINK

Figure 6-6. Left Tunnel Circuits Schematic Diagram for 654xA & 664xA Models Only (sheet 2)

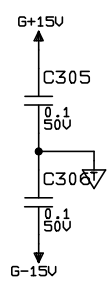
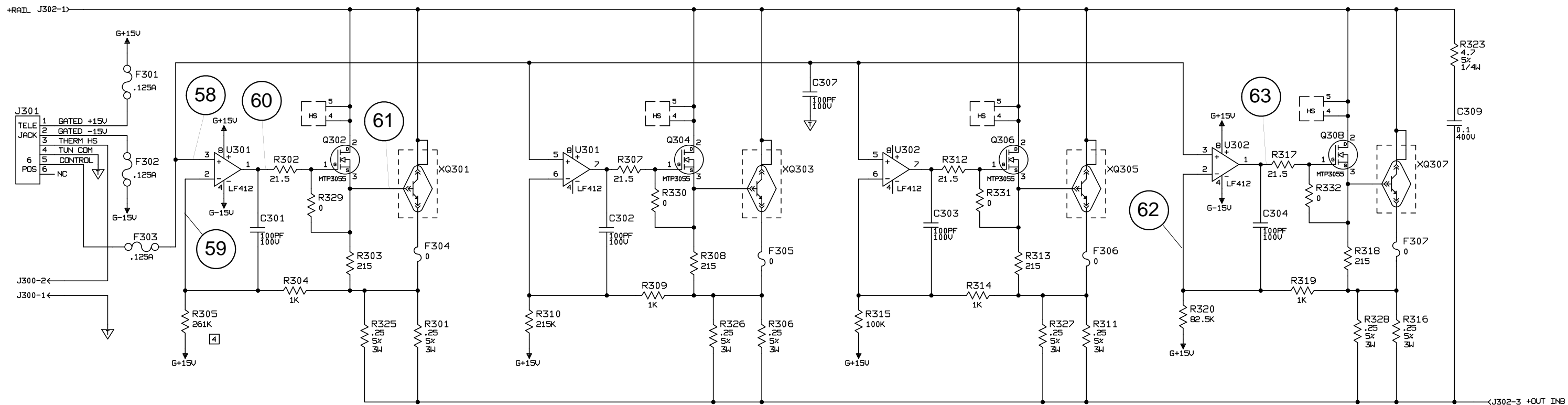

RIGHT TUNNEL BD

NOTE UNLESS OTHERWISE SPECIFIED:

1. ALL RESISTORS ARE IN OHMS +/- 1% 1/8W
2. ALL CAPACITORS ARE IN MICROFARADS
3. Q301, 303, 305, 307 ARE SITTING ON SAME HEATSINK IN THE FOLLOWING ORDER FROM FAN: Q301, 303, 305, 307.

4 DO NOT LOAD THESE COMPONENTS

Figure 6-7. Right Tunnel Circuits Schematic Diagram for 655xA & 665xA Models Only (sheet 1)

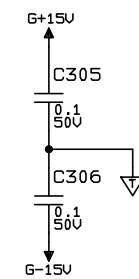
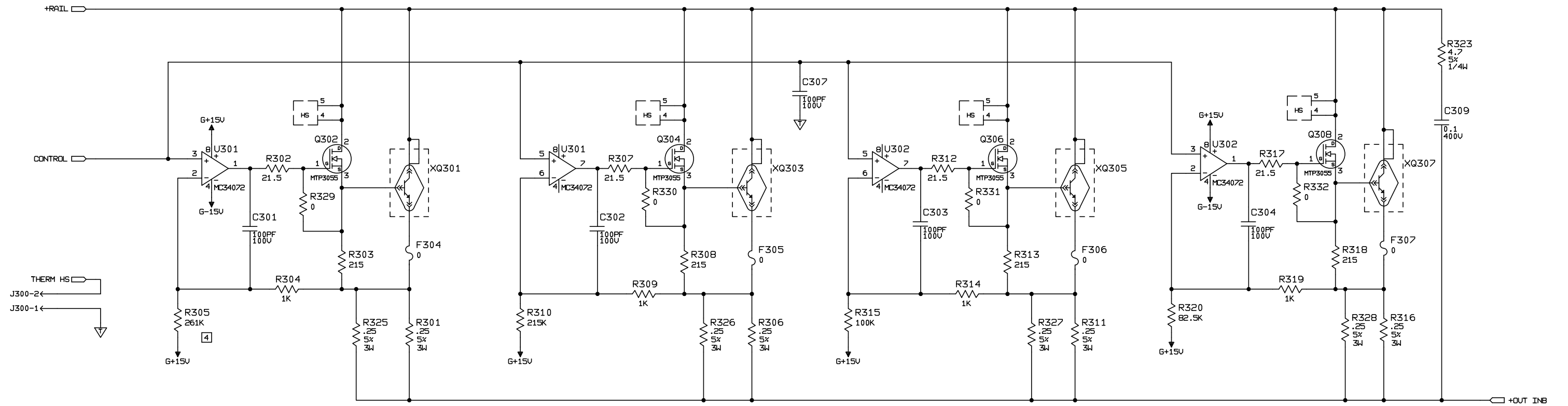

RIGHT TUNNEL NOTES
 NOTE UNLESS OTHERWISE SPECIFIED:
 1. Q301, 303, 305, 307 ARE SITTING ON SAME HEATSINK
 IN THE FOLLOWING ORDER FROM FAN: Q301, 303, 305, 307.

Figure 6-7. Right Tunnel Circuits Schematic Diagram for 654xA & 664xA Models Only (sheet 2)

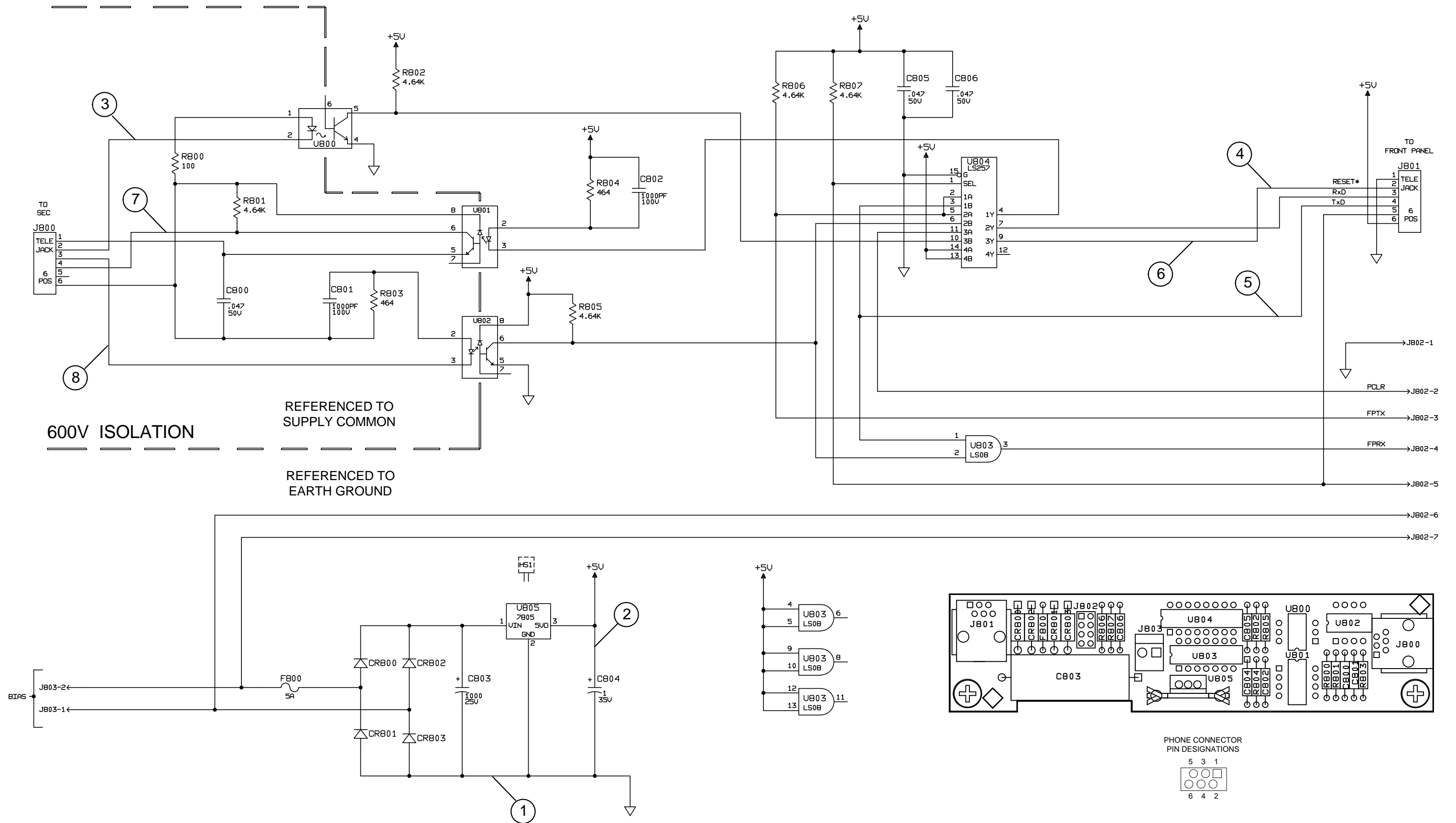

Figure 6-8. A2 Isolator Board Assembly and Schematic Diagram for 654xA & 655xA Models Only

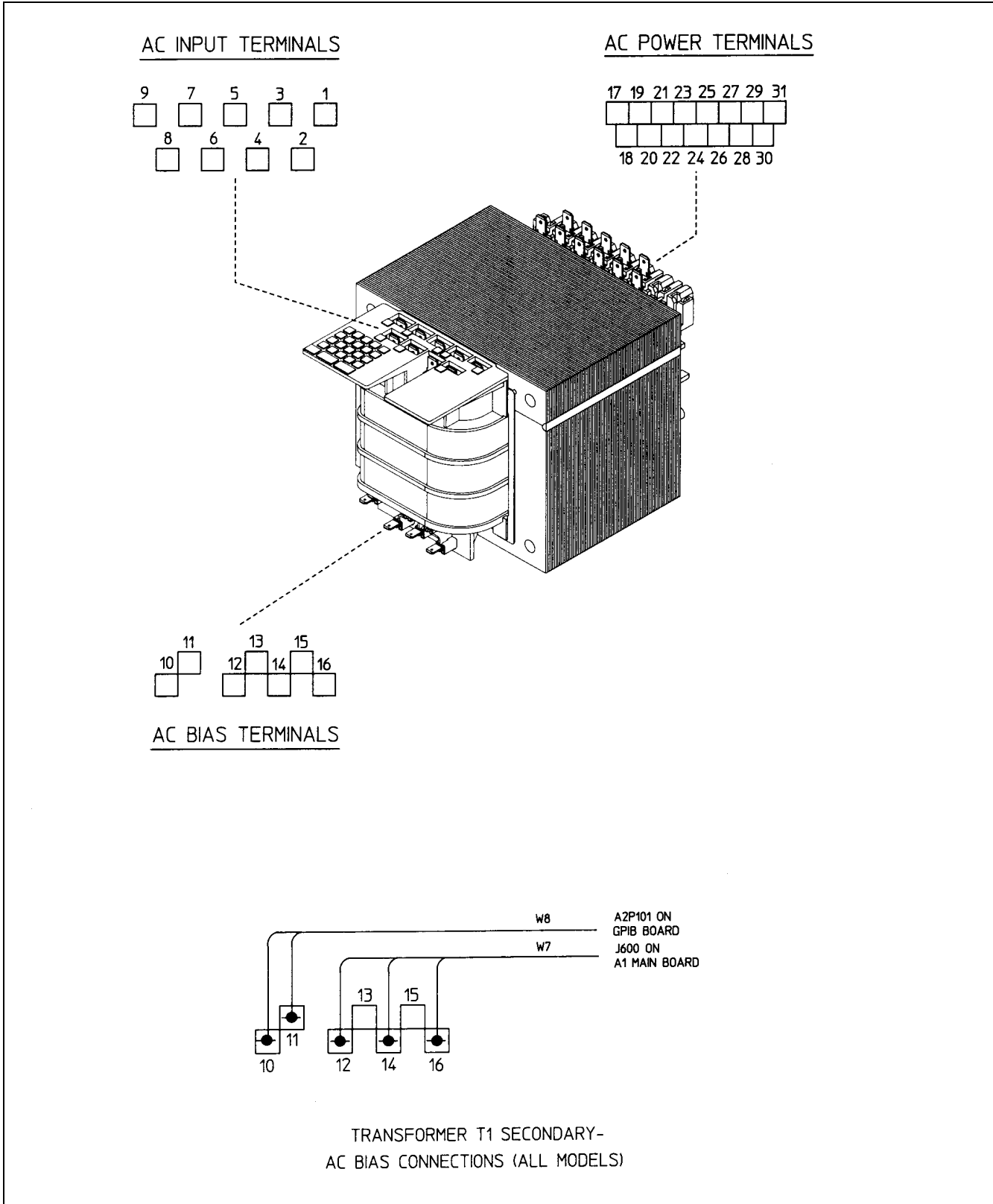

Figure 6-9. Power Transformer Wiring Diagram for Models 655xA and 665xA (Sheet 1 of 3)

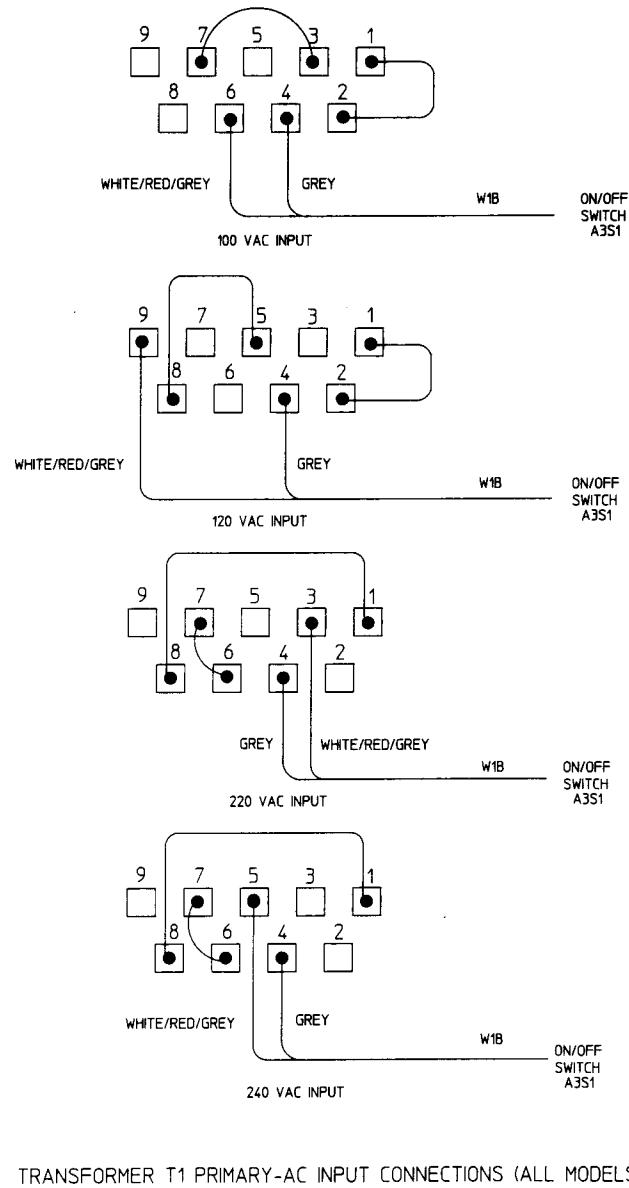

Figure 6-9. Power Transformer Wiring Diagram for Models 655xA and 665xA (Sheet 2 of 3)

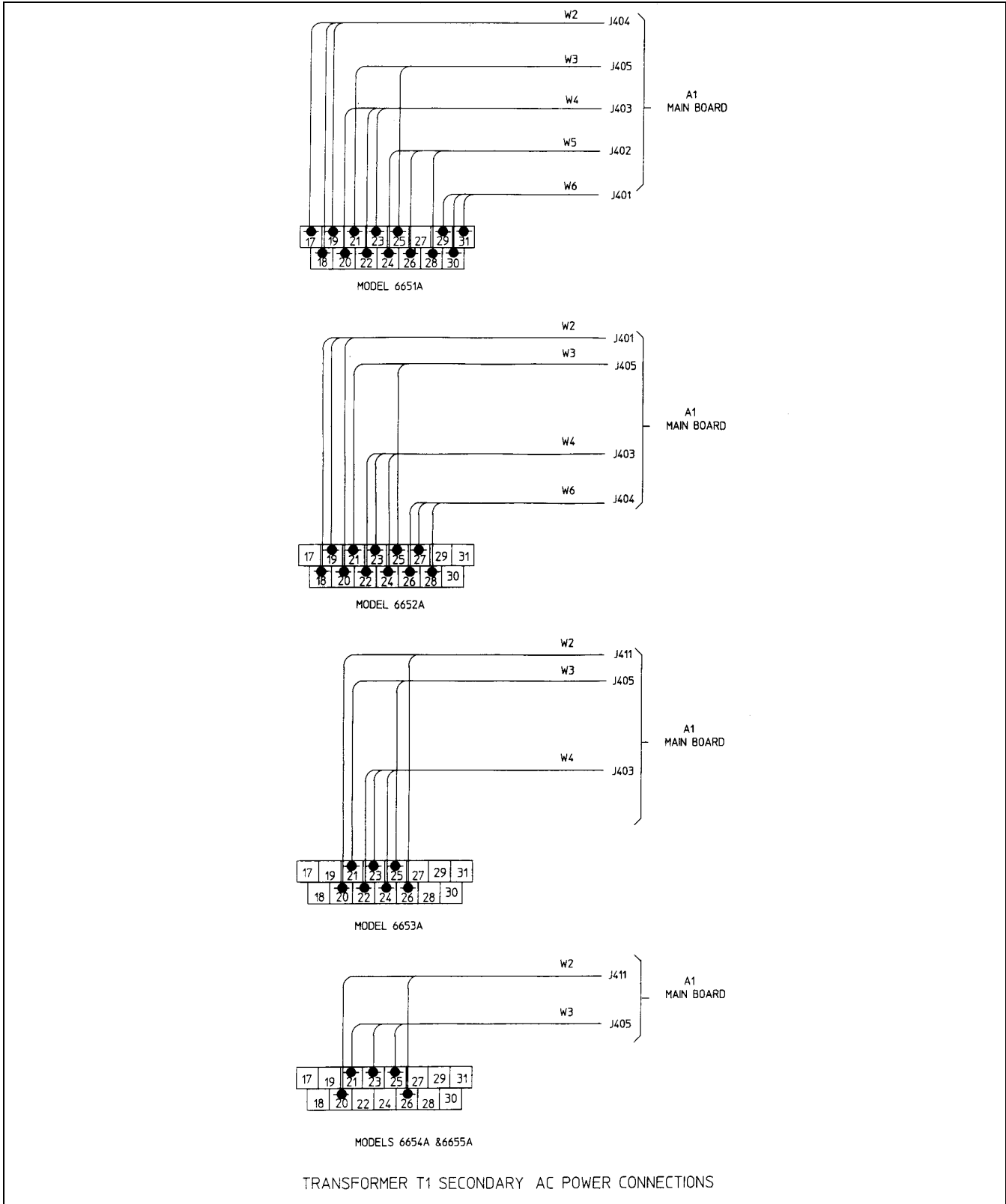

Figure 6-9. Power Transformer Wiring Diagram for Models 655xA and 665xA (Sheet 3 of 3)

Manual Backdating Changes

Manual backdating changes describe changes that must be made to this manual for power supplies with serial numbers that are lower than those listed on the title page. Look in the following table and locate your model power supply. Then look at the serial numbers listed for that model. If any serial number of your power supply is lower than any of the serial numbers listed, then only make the change indicated in the change column for the serial numbers that are higher than the serial number of your unit. Note that several changes may apply to your unit.

Model	Prefix	Serial	Change
6541A	3215A	00108	5
	3215A	00168	17
	3518A	00193	19
	3543A	00223	20
	3620A	00293	24
6542A	3221A	00113	5
	3425A	00238	17
	3519A	00293	19
	3548A	00338	20
	3619A	00393	24
6543A	3218A	00113	5
	3425A	00218	17
	3619A	00408	24
6544A	3219A	00113	5
	3433A	00163	17
	3620A	00233	24
6545A	3215A	00118	5
	3408A	00148	15
	3434A	00168	17
	3623A	00218	24
6551A	3207A	00103	4
	3424A	00153	17
	3533A	00218	19
	3549A	00223	20, 21
	3624A	00228	24, 25
6552A	3203A	00103	4
	3423A	00228	17
	3526A	00323	19
	3541A	00403	20
	3548A	00503	21
	3619A	00758	24
	3632A	00798	25

Model	Prefix	Serial	Change
6553A	3202A	00103	4
	3423A	00281	17
	3549A	00401	21
	3619A	00481	24
	3621A	00486	25
6554A	3205A	00103	4
	3422A	00213	17
	3604A	00333	21, 23
	3620A	00363	24
	3623A	00368	25
6555A	3209A	00103	4
	3402A	00143	15
	3428A	00153	17
	3603A	00193	21, 23
	3622A	00198	25
	3624A	00203	24
6641A	3141A	00106	1
	3217A	00111	5
	3237A	00131	2
	3348A	00236	16
	3504A	00281	18
	3519A	00296	19
	3544A	00351	20
6642A	3619A	00406	24
	3142A	00106	1
	3218A	00126	5
	3235A	00171	2
	3347A	00461	16
	3502A	00771	18
	3518A	00921	19
	3542A	01241	20
3619A	01501	24	

Model	Prefix	Serial	Change
6643A	3142A	00106	1
	3215A	00121	5
	3236A	00171	2
	3346A	00436	16
	3501A	00651	18
	3619A	01146	24
6644A	3142A	00106	1
	3219A	00116	5
	3236A	00156	2
	3346A	00291	16
	3501A	00376	18
	3620A	00696	24
6645A	3141A	00106	1
	3215A	00111	5
	3236A	00146	2
	3346A	00231	16
	3403A	00244	15
	3501A	00373	18
	3620A	00633	24
6651A	3049A	00111	3, 10
	3130A	00171	11
	3220A	00211	5
	3241A	00231	2
	3349A	00281	16
	3501A	00396	18
	3518A	00416	19
	3542A	00466	20
	3548A	00481	21
	3603A	00531	22
	3619A	00621	24
	3620A	00626	25
6652A	3007A	00121	7
	3021A	00151	8, 14
	3035A	00231	3, 9
	3127A	00321	11
	3135A	00371	12, 13
	3217A	00501	5
	3235A	00631	2
	3347A	01271	16
	3501A	01721	18
	3519A	02031	19
	3541A	02361	20
	3548A	02641	21, 22 *
	3617A	02861	24, 25

Model	Prefix	Serial	Change
6653A	3006A	00121	7
	3020A	00171	8, 14
	3035A	00331	3, 9
	3120A	00381	6
	3128A	00659	11
	3136A	00491	12, 13
	3216A	00661	5
	3234A	00741	2
	3347A	01091	16
	3502A	01481	18
	3548A	02121	21
	3602A	02191	22
	3619A	02361	24
	3621A	02381	25
6654A	3007A	00121	7
	3021A	00141	8, 14
	3035A	00241	9
	3036A	00251	3
	3051A	00271	6
	3114A	00311	11
	3137A	00361	12, 13
	3216A	00501	5
	3236A	00561	2
	3348A	00901	16
	3502A	01191	18
	3548A	01511	21
	3602A	01541	22, 23
	3619A	01761	24
	3621A	01781	25
6655A	3050A	00111	3, 10
	3113A	00126	6
	3126A	00151	11
	3126A	00176	1
	3215A	00236	5
	3235A	00261	2
	3347A	00326	16
	3403A	00351	15
	3503A	00491	18
	3548A	00586	21
	3602A	00671	22, 23
	3619A	00801	24
	3622A	00811	25

* Do not make change #22 on units with the following serial numbers: 3617A-02841 through 02845.

- CHANGE 1** In Table 5-5 & 5-7:
Add Capacitor, C740, 4700 pf 10 % 100 V P/N 0160-4831 (Qty 1).
- CHANGE 2** In Table 5-9:
Change Capacitor, C138, from 0.01 uf 10% 100 V P/N 0160-5422 to 0.047 uf 20 % 50 V P/N 0160-4832
Change resistor R134 from 1K 5 % 1/4 W P/N 0683-1025 to 100 ohm 5 % 1/4 W P/N 0683-1015.
- CHANGE 3** In Table 5-9:
Change Capacitor C107 and C108 from 22 pf P/N 0160-4787 to P/N 0160-4807.
In Table 5-10:
Change Capacitors C3 and C4 from 22 pf P/N 0160-4787 to 33 pf P/N 0160-4807.
- CHANGE 4** In Table 5-10:
Remove Magnetic Core (Qty 1) REF. front Panel phone cable P/N 9170-1497.
- CHANGE 5** In Table 5-10:
Change cable assembly for PCB keypad From P/N 5060-3464 to P/N 5060-3427.
Delete Magnetic Core P/N 9170-1497 REF. Front panel phone cable.
- CHANGE 6** In Table 5-5:
Change Resistors R691 and R692 to 1K P/N 0757-0280.
- CHANGE 7** In Table 5- 9:
Change Optoisolators, U110 and U111 from P/N 5080-2176 (Qty 2) to P/N 1990-1387.
- CHANGE 8** In Table 5-9:
Remove Capacitor, C136, 68 pf 5 % 100 V Ceramic P/N 0160-4803.
- CHANGE 9** In Table 5-5:
Change Operational amplifier, U605, from OP270 P/N 1826-2252 (Qty 1) to LT 1057 P/N 1826-1845.
- CHANGE 10** In Table 5-5:
Remove heatsink HS600 P/N 1205-0282 (Keysight 6651A only).
Remove Capacitor, C646, 47 pf P/N 0160-4805.
- CHANGE 11** In Table 5-9:
Change Optoisolator U110, U111 (Qty 2) from P/N 1990-0444 to Lead formed P/N 5080-2176.
Remove Resistor R137 100 ohm 1% 1/8 watt P/N 0757-0401.
Remove Capacitors C138-140, (Qty 3) 0.047 uf, P/N 0160-5422.
Remove Inductor, L101, (Qty 1)150 nH P/N 9100-1610.
- CHANGE 12** In Tables 5-5 & 5-7:
Change Resistor, R785 from 115 ohms 1% 1/8 W P/N 0698-4406 to 68.1 ohm 1% 1/8 W.
- CHANGE 13** In Tables 5-5 & 5-7:
Remove Capacitor C742 (see change 20).
Remove Resistor, R754, 2.15 ohms 1 % 1/8 W P/N 0698-8816 (Qty 1).
Remove Capacitor, C708, 0.01 uf 100 V 10 % ceramic P/N 0160-4832 (Qty 1)
Remove Capacitor, C646, 47 pf 100 V 5 % ceramic P/N 0160-4805 (Qty 1)
- CHANGE 14** In Table 5-9:
Remove standoff-hex REF. GPIB connector P/N 0380-0643 (Qty 2).
Remove Lock washer, M4, REF. GPIB Connector P/N 2190-0586.
Remove rivet, REF. GPIB Clevis P/N 0361-0276.
Change Rear panel from P/N 5001-6742 (Qty 1) to P/N 06652-00002.

Change Connector, J101, from P/N 1252-2047 to P/N 1252-0268.
Change Screw (Qty 2) M3 x 0.5 mm P/N 0515-0911 from REF. Clevis to REF. J101.
Change Nut M3 hex w/lock washer from REF. J101 to P/N 0535-0031.

- CHANGE 15** In Tables 5-5, 5-11, and 5-12:
Change Q201, 203, 207, 301, 303, 305, and 307 to Keysight p/n 1855-0840.
- CHANGE 16** These units have a through-hole A2 GPIB board assembly. The through-hole assembly is the same as the newer surface mount (SMT).assembly functionally and electrically. The only changes are in the size of the assembly, the through hole components and the pin-out numbers of some of the through-hole components. The through-hole board GPIB assembly is documented in Table 5-9B.
- CHANGE 17** In Table 5-8:
Change F800 to 5A, Keysight p/n 2110-0699.
- CHANGE 18** In Table 5-9:
Change U121 to LM309K, Keysight p/n 1820-0430.
- CHANGE 19** In Tables 5-5, 5-11, and 5-12:
Change Q202, 204, 208, 302, 304, 306, and 308 from p/n 5060-3314 back to p/n 5060-3315. NOTE: Do not mix the 5060-3315 FET assemblies with the 5060-3314 FET assemblies in the SAME instrument.
- CHANGE 20** In Tables 5-5, 5-11, and 5-12:
Change Q202, 204, 208, 302, 304, 306, and 308 from p/n 5060-3315 to p/n 5060-3314. NOTE: Do not mix the 5060-3315 FET assemblies with the 5060-3314 FET assemblies in the SAME instrument.
- CHANGE 21** In Table 5-7:
Change Y501 to 12 MHz, p/n 0410-2109.
- CHANGE 22** In Table 5-6:
Delete RFI Strip (ref Cover top), p/n 0160-0895.
- CHANGE 23** In Table 5-7:
Change CR701 to CR700, p/n 1884-0349. Also change D691 to D690, p/n 1901-1182 (Keysight 65/6655), p/n 1901-0317 (Keysight 1901-0317). Also, for Keysight models 65/6655A only, change C418 to p/n 0160-0168.
- CHANGE 24** In Table 5-4:
Change Knob (ref RPG) to p/n 0370-1091. Change Optical encoder to p/n 0960-0822. Change PCA Keypad to p/n 5040-3464.
In Table 5-6:
Change G1,G2 to p/n 0960-0822. Delete PCA Keypad, p/n 5063-3407. Change Knob (A3G1,A3G2) to p/n 0370-1091.
In Table 5-10:
Change U4 to p/n 5080-2208.
- CHANGE 25** In Table 5-11:
Change F201-204 to 0.125A 125V, p/n 2110-0671.
In Table 5-12:
Change F301-304 to 0.125A 125V, p/n 2110-0671.

Index

A

Antistatic wrist strap..... 8

B

Backdating..... 8, 172
Basic test setup..... 11
Built-in tests 11

C

Calibration
 FAC CAL jumper position 90
 INH CAL jumper position 90
 NORMAL 90
 SA MODE jumper position 90
Calibration, from the front panel 90
Calibration procedures 7, 9
CC DAC/Op amplifier 49, 59, 83-86
CC load and line regulation 16
CC noise PARD..... 17
CC setup 15
CC source effect test..... 17
Circuits
 comparator..... 83
 front panel board 89
 isolator board..... 91
 left tunnel..... 86
 Output power & control..... 86, 87
 right tunnel 86
Comparator circuits 83
Constant voltage tests
 CV setup..... 13
Conventions
 200 W Vs. 500 W 7
 GPIB Vs. Analog Programmable 7
Current monitoring resistor 11
Current programming and readback accuracy 15
Current sink operation and readback 16
CV load effect 14
CV noise 14
CV setup..... 13
CV source effect..... 14

D

DC measurements	
taking average reading.....	16
Designators	
parts.....	95
Diagrams	
component location.....	137
I/O interface.....	81
overall block.....	84
overall interconnections.....	137
use of test points.....	139
Diagrams, component location.....	137
Diagrams, detailed block diagram.....	83
Downprogramming resistors.....	88

E

EEPROM, reprogramming the.....	90
EEPROM, unique programmed data.....	90
Electronic load.....	11
Electrostatic discharge	
conductive table mat.....	8
Electrostatic discharge.....	8
Error, output current measurement.....	11

F

Firmware revisions	
front panel ROM chip.....	8
GPIB board ROM chip.....	8
*IDN? query.....	8
Form, performance test record.....	19
Four terminal device.....	13
Functional circuit differences.....	83

G

GPIB board circuits.....	90
GPIB controller	
primary address.....	90
secondary address.....	90
GPIB, serial link.....	90
GPIB, values read using.....	13

H

Hazardous Voltages.....	8
Hazards, shock.....	9

I

*IDN query..... 8, 41
Index, to power supply assemblies 95
Interface, GPIB communications..... 81
Interface signals, power supply 81
Isolator board circuits..... 91

J

Jumper block, A3J3..... 90

K

Keysight 3458A system voltmeter..... 16

L

LCD display, front panel 89
Loads
 electronic 11

M

Manual revisions 8
Manuals operating 8
Measurement techniques 11
Model differences
 between AI main board & heat sink assembly 86

N

Negative logic signals
 asterisk vs. bar 7

O

Ordering parts..... 95
Overall troubleshooting procedures..... 34, 37-40

P

PARD, CC constant current..... 17
PARD, CC noise..... 17
PARD, CV noise 14
PARD, periodic and random deviations 17
PARD tests 11

Part reference designators.....	95
Parts	
component location diagrams.....	137
Parts, ordering information.....	95
Performance degradation electrostatic.....	8
Performance test record.....	11
Performance test record form.....	19
Performance tests.....	11
Power supplies	
models.....	7
Power supply	
serial numbers.....	8
Power supply assemblies, index to.....	95
Power supply models.....	7
Programming	
current and readback.....	15
from front panel.....	13
from GPIB controller.....	13
remotely.....	13

R

Recovery, transient time.....	15
Regulation, tests of DC current.....	16
Remote sensing leads.....	11, 72
Replaceable parts.....	96
for 200 watt main chassis.....	96
Resistors	
current-monitoring.....	11
fixed load.....	11
variable load.....	11

S

Safety considerations	
hazardous voltages.....	8
safety symbols.....	3
SA secondary interface, exiting test.....	46-48
SA signals	
A5 microprocessor.....	46-48
SA signals, secondary interface.....	46-48
Schematics, circuit board.....	137
Secondary interface circuits.....	83
Sense switch.....	88
Sense switch, use of.....	11
Serial numbers.....	8
Settling times.....	11
Shock hazard.....	9

Signals	
+5 V bias voltage.....	91-93
BSTx	93
CCPROG.....	88
CVPROG.....	88
FAN PWM	89
FAN PWM signal.....	89
IMON	88
INHIBIT	88
Output Control.....	86
OVCMP.....	85
OVPROG	85
OVSCR.....	85, 88
PCLR.....	91, 92
+RAIL	86
RESET*.....	92
RxD	91, 93
SPCLR*.....	92, 93
SRx.....	93
TxD	91, 93
VMON.....	88
XFMR T1	92
Slew rates	11
SPCLR.....	92
Specifications, operating manual.....	9

T

TB101, terminal strip	91
Test equipment required	9, 10
Test points	139
for AI main board	141
for A4A1/A4A3 left tunnel board.....	143
for A4A2/A4A4 right tunnel board	144
for GPIB board	140
for isolator board	140
Test procedures	11
Test record tables	11
Tests	
basic test set up.....	11
CC noise PARD.....	17
CC setup	15
CC source effect	17
current programming	15
current sink operation and readback.....	16
CV load effect	14
CV Noise.....	14
CV source effect.....	14
equipment required.....	9
load and line regulation	16
operation verification	11

PARD	14
performance test record	11, 19
performance tests	11
setup for most tests	11
transient recovery time	15
voltage and current values	13
voltage programming and readback accuracy	13
Tests, power supply	
abnormal results	9
built-in	9
performance	9
verification	9
Transformer, AC input connections	137
Transient recovery time	15
Transient response waveform	15

V

Verification, operation tests	11
Verification tests	9
Voltage and current values	13
Voltage programming and readback accuracy	13

W

Wait statements	11
Waveform, transient response	15

GYfJU`Bi a VYfg

For instruments with Serial Numbers:

Keysight Model 6541A: US36360101 and above *
Keysight Model 6542A: US36360101 and above *
Keysight Model 6543A: US36340101 and above *
Keysight Model 6544A: US36390101 and above *
Keysight Model 6545A: US36340101 and above *

Keysight Model 6551A: US36480101 and above *
Keysight Model 6552A: US36230101 and above *
Keysight Model 6553A: US36340101 and above *
Keysight Model 6554A: US36340101 and above *
Keysight Model 6555A: US36340101 and above *

Keysight Model 6641A: US36410101 and above *
Keysight Model 6642A: US36400101 and above *
Keysight Model 6643A: US36400101 and above *
Keysight Model 6644A: US36410101 and above *
Keysight Model 6645A: US36390101 and above *

Keysight Model 6651A: US36400101 and above *
Keysight Model 6652A: US36400101 and above *
Keysight Model 6653A: US36400101 and above *
Keysight Model 6654A: US36390101 and above *
Keysight Model 6655A: US36390101 and above *

* For instruments with higher serial numbers, a change page may be included.
For instruments with lower serial numbers, see Appendix A.



This information is subject to change without notice.
© Keysight Technologies 1993, 2000, 2014
Edition 3, December 2014



5959-3376

www.keysight.com