

Model 2182/2182A Nanovoltmeter

Service Manual

2182A-902-01 Rev. A / July 2004

KEITHLEY

A GREATER MEASURE OF CONFIDENCE

WARRANTY

Keithley Instruments, Inc. warrants this product to be free from defects in material and workmanship for a period of one (1) year from date of shipment.

Keithley Instruments, Inc. warrants the following items for 90 days from the date of shipment: probes, cables, software, rechargeable batteries, diskettes, and documentation.

During the warranty period, Keithley Instruments will, at its option, either repair or replace any product that proves to be defective.

To exercise this warranty, write or call your local Keithley Instruments representative, or contact Keithley Instruments headquarters in Cleveland, Ohio. You will be given prompt assistance and return instructions. Send the product, transportation prepaid, to the indicated service facility. Repairs will be made and the product returned, transportation prepaid. Repaired or replaced products are warranted for the balance of the original warranty period, or at least 90 days.

LIMITATION OF WARRANTY

This warranty does not apply to defects resulting from product modification without Keithley Instruments' express written consent, or misuse of any product or part. This warranty also does not apply to fuses, software, non-rechargeable batteries, damage from battery leakage, or problems arising from normal wear or failure to follow instructions.

THIS WARRANTY IS IN LIEU OF ALL OTHER WARRANTIES, EXPRESSED OR IMPLIED, INCLUDING ANY IMPLIED WARRANTY OF MERCHANTABILITY OR FITNESS FOR A PARTICULAR USE. THE REMEDIES PROVIDED HEREIN ARE THE BUYER'S SOLE AND EXCLUSIVE REMEDIES.

NEITHER KEITHLEY INSTRUMENTS, INC. NOR ANY OF ITS EMPLOYEES SHALL BE LIABLE FOR ANY DIRECT, INDIRECT, SPECIAL, INCIDENTAL, OR CONSEQUENTIAL DAMAGES ARISING OUT OF THE USE OF ITS INSTRUMENTS AND SOFTWARE, EVEN IF KEITHLEY INSTRUMENTS, INC. HAS BEEN ADVISED IN ADVANCE OF THE POSSIBILITY OF SUCH DAMAGES. SUCH EXCLUDED DAMAGES SHALL INCLUDE, BUT ARE NOT LIMITED TO: COST OF REMOVAL AND INSTALLATION, LOSSES SUSTAINED AS THE RESULT OF INJURY TO ANY PERSON, OR DAMAGE TO PROPERTY.

KEITHLEY

A GREATER MEASURE OF CONFIDENCE

Keithley Instruments, Inc.

Corporate Headquarters • 28775 Aurora Road • Cleveland, Ohio 44139
440-248-0400 • Fax: 440-248-6168 • 1-888-KEITHLEY (1-888-534-8453) • www.keithley.com

3/07

Model 2182/2182A Nanovoltmeter Service Manual

This Service Manual supports both the Models 2182 and 2182A.
References to the Model 2182 also apply to the Model 2182A.

©2004, Keithley Instruments, Inc.
All rights reserved.
Cleveland, Ohio, U.S.A.
First Printing, July 2004
Document Number: 2182A-902-01 Rev. A

Manual Print History

The print history shown below lists the printing dates of all Revisions and Addenda created for this manual. The Revision Level letter increases alphabetically as the manual undergoes subsequent updates. Addenda, which are released between Revisions, contain important change information that the user should incorporate immediately into the manual. Addenda are numbered sequentially. When a new Revision is created, all Addenda associated with the previous Revision of the manual are incorporated into the new Revision of the manual. Each new Revision includes a revised copy of this print history page.

Revision A (Document Number 2182A-902-01) July 2004

The following safety precautions should be observed before using this product and any associated instrumentation. Although some instruments and accessories would normally be used with non-hazardous voltages, there are situations where hazardous conditions may be present.

This product is intended for use by qualified personnel who recognize shock hazards and are familiar with the safety precautions required to avoid possible injury. Read and follow all installation, operation, and maintenance information carefully before using the product. Refer to the user documentation for complete product specifications. If the product is used in a manner not specified, the protection provided by the product warranty may be impaired.

The types of product users are:

Responsible body is the individual or group responsible for the use and maintenance of equipment, for ensuring that the equipment is operated within its specifications and operating limits, and for ensuring that operators are adequately trained.

Operators use the product for its intended function. They must be trained in electrical safety procedures and proper use of the instrument. They must be protected from electric shock and contact with hazardous live circuits.

Maintenance personnel perform routine procedures on the product to keep it operating properly, for example, setting the line voltage or replacing consumable materials. Maintenance procedures are described in the user documentation. The procedures explicitly state if the operator may perform them. Otherwise, they should be performed only by service personnel.

Service personnel are trained to work on live circuits, perform safe installations, and repair products. Only properly trained service personnel may perform installation and service procedures.

Keithley Instruments products are designed for use with electrical signals that are rated Measurement Category I and Measurement Category II, as described in the International Electrotechnical Commission (IEC) Standard IEC 60664. Most measurement, control, and data I/O signals are Measurement Category I and must not be directly connected to mains voltage or to voltage sources with high transient over-voltages. Measurement Category II connections require protection for high transient over-voltages often associated with local AC mains connections. Assume all measurement, control, and data I/O connections are for connection to Category I sources unless otherwise marked or described in the user documentation.

Exercise extreme caution when a shock hazard is present. Lethal voltage may be present on cable connector jacks or test fixtures. The American National Standards Institute (ANSI) states that a shock hazard exists when voltage levels greater than 30V RMS, 42.4V peak, or 60VDC are present. A good safety practice is to expect that hazardous voltage is present in any unknown circuit before measuring.

Operators of this product must be protected from electric shock at all times. The responsible body must ensure that operators are prevented access and/or insulated from every connection point. In some cases, connections must be exposed to potential human contact. Product operators in these circumstances must be trained to protect themselves from the risk of electric shock. If the circuit is capable of operating at or above 1000 volts, no conductive part of the circuit may be exposed.

Do not connect switching cards directly to unlimited power circuits. They are intended to be used with impedance-limited sources. NEVER connect switching cards directly to AC mains. When connecting sources to switching cards, install protective devices to limit fault current and voltage to the card.

Before operating an instrument, make sure the line cord is connected to a properly grounded power receptacle. Inspect the connecting cables, test leads, and jumpers for possible wear, cracks, or breaks before each use.

When installing equipment where access to the main power cord is restricted, such as rack mounting, a separate main input power disconnect device must be provided in close proximity to the equipment and within easy reach of the operator.

For maximum safety, do not touch the product, test cables, or any other instruments while power is applied to the circuit under test. ALWAYS remove power from the entire test system and discharge any capacitors before: connecting or disconnecting cables or jumpers, installing or removing switching cards, or making internal changes, such as installing or removing jumpers.

Do not touch any object that could provide a current path to the common side of the circuit under test or power line (earth) ground. Always make measurements with dry hands while standing on a dry, insulated surface capable of withstanding the voltage being measured.

The instrument and accessories must be used in accordance with specifications and operating instructions, or the safety of the equipment may be impaired.

Do not exceed the maximum signal levels of the instruments and accessories, as defined in the specifications and operating information, and as shown on the instrument or test fixture panels, or switching card.

When fuses are used in a product, replace with the same type and rating for continued protection against fire hazard.

Chassis connections must only be used as shield connections for measuring circuits, NOT as safety earth ground connections.

If you are using a test fixture, keep the lid closed while power is applied to the device under test. Safe operation requires the use of a lid interlock.

If a  screw is present, connect it to safety earth ground using the wire recommended in the user documentation.

The  symbol on an instrument indicates that the user should refer to the operating instructions located in the documentation.

The  symbol on an instrument shows that it can source or measure 1000 volts or more, including the combined effect of normal and common mode voltages. Use standard safety precautions to avoid personal contact with these voltages.

The  symbol on an instrument shows that the surface may be hot. Avoid personal contact to prevent burns.

The  symbol indicates a connection terminal to the equipment frame.

If this  symbol is on a product, it indicates that mercury is present in the display lamp. Please note that the lamp must be properly disposed of according to federal, state, and local laws.

The **WARNING** heading in the user documentation explains dangers that might result in personal injury or death. Always read the associated information very carefully before performing the indicated procedure.

The **CAUTION** heading in the user documentation explains hazards that could damage the instrument. Such damage may invalidate the warranty.

Instrumentation and accessories shall not be connected to humans.

Before performing any maintenance, disconnect the line cord and all test cables.

To maintain protection from electric shock and fire, replacement components in mains circuits - including the power transformer, test leads, and input jacks - must be purchased from Keithley Instruments. Standard fuses with applicable national safety approvals may be used if the rating and type are the same. Other components that are not safety-related may be purchased from other suppliers as long as they are equivalent to the original component (note that selected parts should be purchased only through Keithley Instruments to maintain accuracy and functionality of the product). If you are unsure about the applicability of a replacement component, call a Keithley Instruments office for information.

To clean an instrument, use a damp cloth or mild, water-based cleaner. Clean the exterior of the instrument only. Do not apply cleaner directly to the instrument or allow liquids to enter or spill on the instrument. Products that consist of a circuit board with no case or chassis (e.g., data acquisition board for installation into a computer) should never require cleaning if handled according to instructions. If the board becomes contaminated and operation is affected, the board should be returned to the factory for proper cleaning/servicing.

Table of Contents

1 Performance Verification

Introduction	1-2
Verification test requirements	1-2
Environmental conditions	1-2
Warm-up period	1-3
Line power	1-3
Recommended test equipment	1-3
Verification reading limits	1-4
Restoring factory defaults	1-4
Auto-calibration (ACAL)	1-4
Performing the verification test procedures	1-5
Test summary	1-5
Test considerations	1-5
Verification procedures	1-6
Voltage measurement accuracy	1-6
Temperature measurement accuracy	1-8
Analog output accuracy	1-10

2 Calibration

Introduction	2-2
Environmental conditions	2-2
Temperature and relative humidity	2-2
Calibration considerations	2-3
Calibration cycle	2-3
Calibration menu	2-3
Calibration errors	2-5
Aborting calibration	2-6
Normal calibration	2-6
Recommended calibration equipment	2-6
Front panel calibration	2-6
Remote calibration	2-10
Factory calibration	2-12
Recommended test equipment	2-12
Remote factory calibration	2-13

3 Routine Maintenance

Introduction	3-2
Line fuse replacement	3-2
Line voltage selection	3-3

4 Troubleshooting

Introduction	4-2
Repair considerations	4-2
Power-on self-test	4-3
Front panel tests	4-3
KEY test	4-3
DISP test	4-3
Principles of operation	4-4
Power supply	4-4
Display board	4-5
Digital circuitry	4-6
Analog circuitry	4-7
Troubleshooting	4-10
Display board checks	4-10
Power supply checks	4-11
Digital circuit checks	4-12
Analog circuit checks	4-13
Analog signal switching states	4-14
No comm link error	4-16

5 Disassembly

Introduction	5-2
Handling and cleaning	5-2
Handling PC boards	5-2
Solder repairs	5-2
Static sensitive devices	5-3
Assembly drawings	5-3
Disassembly	5-4
Case cover removal	5-4
Motherboard removal	5-5
Front panel disassembly	5-5
Main CPU firmware replacement	5-6
Changing trigger link lines	5-7
Removing power components	5-8
Power transformer removal	5-8
Power module removal	5-8
Instrument reassembly	5-9
Power module connections	5-9
Board installation	5-9

6 Replaceable Parts

Introduction	6-2
Parts lists	6-2
Ordering information	6-2
Factory service	6-2
Component layouts	6-2

A Specifications

B Calibration Reference

Introduction	B-2
Command summary	B-3
Default calibration constants and tolerances	B-4
Miscellaneous commands	B-6
:CODE	B-6
:COUNT?	B-6
:LOCK	B-7
:SAVE	B-7
:DATE	B-8
:NDUE	B-8
:DATA?	B-9
Calibration step commands	B-9
:DC	B-9
Precalibration commands	B-10
:PCAL	B-10
Detecting calibration errors	B-11
Reading the error queue	B-11
Error summary	B-11
Status byte EAV (Error Available) bit	B-12
Generating an SRQ on error	B-12
Detecting calibration step completion	B-13
Using the *OPC command	B-13

C Calibration Program

Introduction	C-2
Computer hardware requirements	C-2
Software requirements	C-2
Calibration equipment	C-2
General program instructions	C-3

List of Illustrations

1 Performance Verification

Figure 1-1	Connections for 100mV-100V range accuracy	1-6
Figure 1-2	Connections for 10mV range accuracy	1-7
Figure 1-3	Connections for temperature accuracy verification	1-9
Figure 1-4	Connections for analog output accuracy	1-11

2 Calibration

Figure 2-1	Low-thermal short connections	2-7
Figure 2-2	Connections for DC volts calibration	2-8
Figure 2-3	Connections for factory DC volts calibration	2-14
Figure 2-4	Low thermal short connections for factory calibration	2-15
Figure 2-5	Connections for analog output calibration	2-16

3 Routine Maintenance

Figure 3-1	Line fuse replacement	3-2
------------	-----------------------------	-----

4 Troubleshooting

Figure 4-1	Power supply block diagram	4-4
Figure 4-2	Digital circuitry block diagram	4-5
Figure 4-3	Simplified schematic of analog circuitry	4-8

List of Tables

1 Performance Verification

Table 1-1	Recommended verification equipment	1-3
Table 1-2	Input cable color codes	1-6
Table 1-3	DC voltage measurement accuracy limits	1-8
Table 1-4	Temperature measurement accuracy limits	1-10
Table 1-5	Analog output accuracy limits	1-11

2 Calibration

Table 2-1	Calibrating menu	2-3
Table 2-2	Recommended normal calibration equipment	2-6
Table 2-3	Input cable color codes	2-8
Table 2-4	DC volts front panel calibration summary	2-9
Table 2-5	DC voltage remote calibration programming steps	2-11
Table 2-6	Recommended factory calibration equipment	2-12
Table 2-7	Remote precalibration steps	2-14
Table 2-8	DC voltage remote calibration programming steps	2-15

3 Routine Maintenance

Table 3-1	Power line fuse ratings	3-3
-----------	-------------------------------	-----

4 Troubleshooting

Table 4-1	Circuit gain factors	4-10
Table 4-2	Display board checks	4-10
Table 4-3	Power supply checks	4-11
Table 4-4	Digital circuit checks	4-12
Table 4-5	Analog circuit checks	4-13
Table 4-6	Signal multiplexing gain switching	4-14
Table 4-7	Input protection and low-noise preamplifier analog switching states	4-15

5 Disassembly

Table 5-1	Trigger link connections	5-7
Table 5-2	Power module connections	5-9

6 **Replaceable Parts**

Table 6-1	Motherboard parts list	6-3
Table 6-2	Motherboard parts list (continued)	6-4
Table 6-3	Motherboard parts list (continued)	6-6
Table 6-4	Motherboard parts list (continued)	6-7
Table 6-5	Motherboard parts list (continued)	6-8
Table 6-6	Motherboard parts list (continued)	6-9
Table 6-7	Display board parts list	6-9
Table 6-8	Connector board parts list	6-10
Table 6-9	Mechanical parts list	6-10

B **Calibration Reference**

Table B-1	Remote calibration command summary	B-3
Table B-2	Default calibration constants and tolerances	B-5
Table B-3	Calibration steps	B-9
Table B-4	Precal steps	B-10
Table B-5	Calibration errors	B-11

1 Performance Verification

Introduction

Use the procedures in this section to verify that Model 2182 accuracy is within the limits stated in the instrument's one-year accuracy specifications. You can perform these verification procedures:

- When you first receive the instrument to make sure that it was not damaged during shipment.
- To verify that the unit meets factory specifications.
- To determine if calibration is required.
- Following calibration to make sure it was performed properly.

WARNING The information in this section is intended only for qualified service personnel. Do not attempt these procedures unless you are qualified to do so. Some of these procedures may expose you to hazardous voltages, which could cause personal injury or death if contacted. Use standard safety precautions when working with hazardous voltages.

NOTE *If the instrument is still under warranty, and its performance is outside specified limits, contact your Keithley representative or the factory to determine the correct course of action.*

Verification test requirements

Be sure that you perform the verification tests:

- Under the proper environmental conditions.
- After the specified warm-up period.
- Using the correct line voltage.
- Using the proper test equipment.
- Using the specified output signals and reading limits.

Environmental conditions

Conduct your performance verification procedures in a test environment with:

- An ambient temperature of 18-28°C (65-82°F).
- A relative humidity of less than 70% unless otherwise noted.

Warm-up period

Allow the Model 2182 to warm up for at least 2-1/2 hours before conducting the verification procedures. If the instrument has been subjected to temperature extremes (those outside the ranges stated above), allow additional time for the instrument's internal temperature to stabilize. Typically, allow one extra hour to stabilize a unit that is 10°C (18°F) outside the specified temperature range.

Also, allow the test equipment to warm up for the minimum time specified by the manufacturer.

Line power

The Model 2182 requires a nominal line voltage of 100, 120, 220, or 240V and a line frequency of 50 to 60Hz or 400Hz. Verification tests must be performed with the correct line voltage. If necessary, change the line voltage setting as covered in [Section 3](#).

Recommended test equipment

[Table 1-1](#) summarizes recommended verification equipment. You can use alternate equipment as long as that equipment has specifications at least four times better than corresponding Model 2182 specifications. Keep in mind, however, that test equipment accuracy will add to the uncertainty of each measurement.

Table 1-1
Recommended verification equipment

Description	Manufacturer/Model	Specifications*
DC Calibrator	Fluke 5700A	100mV: ± 14 ppm 1V: ± 7 ppm 10V: ± 5 ppm 100V: ± 7 ppm
Low Thermal Divider		100:1 division: ± 5 ppm
Thermocouple Calibrator	Omega CL523	Type J: -200 to 700°C Type K, N : -200 to 1300°C Type N: -200 to 400°C Type E: -200 to 1000°C Type R, S: 0 to 1700°C Type B: 400 to 1700°C
Digital Multimeter	Keithley 2000	1V: ± 32 ppm
Low Thermal Cable	Keithley 2107	
Low Thermal Cable	Keithley 1506	
BNC-to-dual banana jack cable		

*DC calibrator specifications shown include total 90-day 23°C ± 5 °C uncertainty at specified output. Model 262 error includes a short-term transfer error of ± 5 ppm at 23°C ± 1 °C. Digital multimeter specification is 90-day, 23°C ± 5 °C full-range value.

Verification reading limits

The verification limits stated in this section have been calculated using only the Model 2182 one-year accuracy specifications, and *they do not include test equipment uncertainty*. If a particular measurement falls outside the allowable range, recalculate new limits based both on Model 2182 specifications and corresponding test equipment specifications.

Example limits calculation

As an example of how verification limits are calculated, assume you are testing the 10V DC voltage range using a 10V input value. Using the Model 2182 10V range one-year accuracy specification of $\pm(25\text{ppm of reading} + 2\text{ppm of range})$, the calculated reading limits are:

$$\text{Reading limits} = 10\text{V} \pm [(10\text{V} \times 25\text{ppm}) + (10\text{V} \times 2\text{ppm})]$$

$$\text{Reading limits} = 10\text{V} \pm (250\mu\text{V} + 20\mu\text{V})$$

$$\text{Reading limits} = 10\text{V} \pm 270\mu\text{V}$$

$$\text{Reading limits} = 9.99973 \text{ to } 10.00027\text{V}$$

Restoring factory defaults

Before performing the verification procedures, restore the instrument to its factory front panel default conditions as follows:

1. Press SETUP RESTR. The instrument will display the following prompt:
RESTORE: FACT
2. Using either RANGE key, select FACT, then restore the factory default conditions by pressing ENTER.

NOTE You can use either RANGE key to toggle between FACT and USER setups. Be sure you use factory defaults for the verification procedures.

Auto-calibration (ACAL)

Before verifying accuracy, perform an auto-calibration to ensure the instrument meets its specifications. Do the following:

1. Disconnect the test cable from the input jack.

CAUTION Do not perform full auto-calibration with a test voltage connected to the input jack, or the instrument may be damaged.

2. Turn on the instrument power, and allow the unit to warm up for at least 2-1/2 hours.
3. Press the ACAL key. The instrument will prompt you as follows:

ACAL: LOW-LVL

- Using either RANGE key, select FULL, then press ENTER. The unit will then remind you to disconnect the input cable:

REMOVE INPUT

- Make sure the input cable is disconnected, then press ENTER. The unit will then perform auto-calibration, a process that will take several minutes to complete. During this period, the unit will display:

ACAL

NOTE *LOW-LVL ACAL performs a new gain calibration for the 10mV range only based on 10V calibration. FULL ACAL performs both a 100V and 10mV gain calibration based on the last 10V calibration.*

Performing the verification test procedures

Test summary

- DC voltage measurement accuracy
- Temperature measurement accuracy
- Analog output accuracy

If the Model 2182 is not within specifications and not under warranty, see the calibration procedures in [Section 2](#) for information on calibrating the unit.

Test considerations

When performing the verification procedures:

- Be sure to restore factory front panel defaults, and perform a full auto-calibration (ACAL), as outlined above.
- Make sure that the Model 2182 and test equipment are properly warmed up, and that the test equipment is connected to the appropriate Model 2182 jacks.
- Be sure the test equipment is set up for the proper function and range.
- Allow the test signal to settle before making a measurement.
- Use only copper-to-copper connections to minimize thermal EMFs.
- Make sure that all connections are clean and free of oxidation to avoid thermal EMFs that could affect measurement accuracy. Clean oxidation from connector terminals with DeoxIT cleaning solution.
- Keep test connections and all equipment away from drafts to avoid thermal drift.
- Do not connect test equipment to the Model 2182 through a scanner, multiplexer, or other switching equipment.
- Do not use autoranging because autorange hysteresis may cause the Model 2182 to be on an incorrect range.

WARNING The maximum voltage between any terminals to chassis ground is 350V peak. Exceeding this value may cause a breakdown in insulation, creating a shock hazard.

CAUTION The maximum voltage between CHANNEL 1 HI and LO is 120V. The maximum voltage between CHANNEL 2 HI and LO is 12V. Exceeding these voltage values may result in instrument damage.

Verification procedures

Voltage measurement accuracy

Follow the steps below to verify that Model 2182 voltage measurement accuracy is within specified limits. The test involves applying precise DC voltages and then verifying that the Model 2182 voltage readings are within required limits.

100mV – 100V range accuracy

1. With the power off, connect the DC calibrator to CHANNEL 1 of the Model 2182 input jack, as shown in [Figure 1-1](#). Connections for the Model 2107 Low Thermal Input Cable are summarized in [Table 1-2](#).

Table 1-2

Input cable color codes

Input connection	Wire color
Channel 1 HI	Red
Channel 1 LO	Black
Channel 2 HI	Green
Channel 2 LO	White

Figure 1-1

Connections for 100mV-100V range accuracy

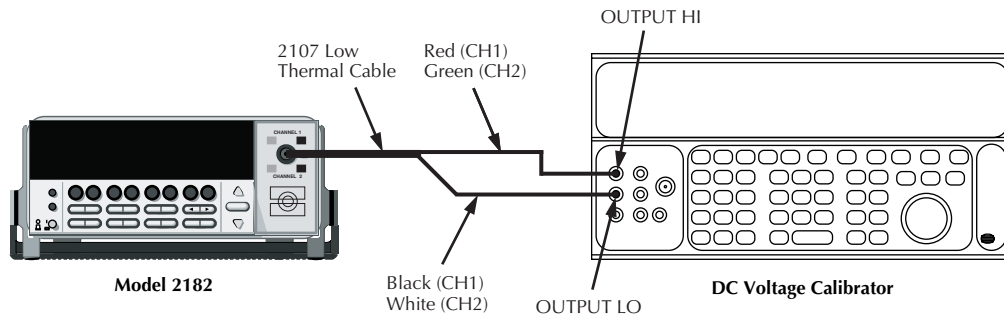

2. Turn on the power, and allow a 2-1/2 hour warm-up period.
3. Restore factory defaults, and do a full auto-calibration, as previously described.
4. Select the Model 2182 DCV1 measurement function, and select the 100mV range.
5. Set the calibrator output to 0.00000mV, and allow the reading to settle.
6. Enable REL, and leave it enabled for the remainder of the tests.
7. Verify reading accuracy for each of the voltages listed in [Table 1-3](#). For each test point:
 - Select the correct Model 2182 measurement range.
 - Set the DC calibrator output voltage to the indicated value.
 - Verify that the Model 2182 voltage reading is within the limits given in the table.
8. Repeat step 7 for negative source voltages with the same magnitudes as those listed in [Table 1-3](#).
9. Repeat steps 4 through 8 for the 100mV-10V ranges of the CHANNEL 2 input. Be sure to connect the calibrator to the appropriate input jack terminals by changing input cable wire connections, and select the DCV2 measurement function.

10mV range accuracy

1. With the power off, connect the DC calibrator and low-thermal divider to the Model 2182 CHANNEL 1 terminals of the input jack, as shown in [Figure 1-2](#).

Figure 1-2
Connections for 10mV range accuracy

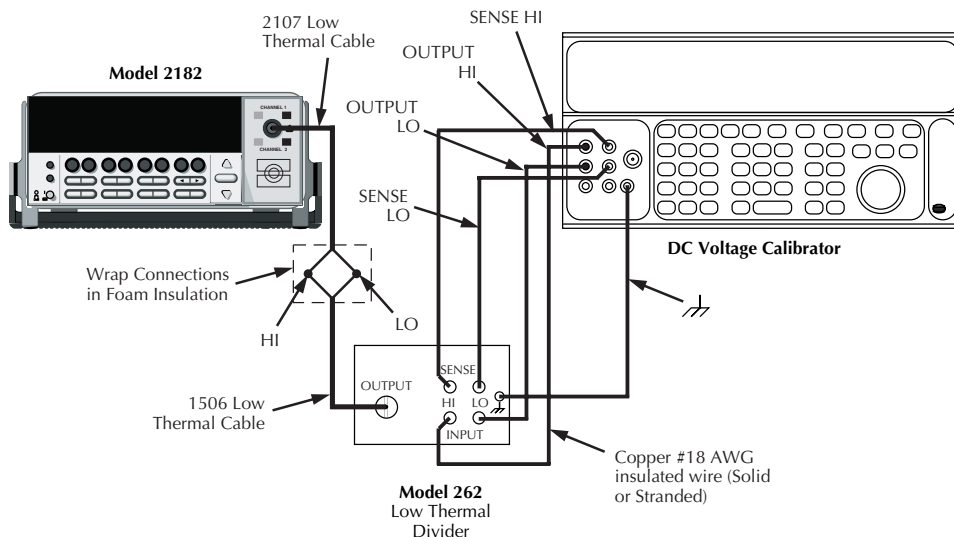

2. Turn on the power, and allow a 2-1/2 hour warm-up period.
3. Select the Model 2182 DCV1 measurement function, and choose the 10mV range.
4. Select the 100:1 divider ratio.
5. Set the calibrator output to 0.00000V, and allow the reading to settle.
6. Enable REL.

7. Set the DC calibrator output voltage to 1.000000V.
8. Verify voltage reading accuracy for the 10mV range listed in [Table 1-3](#).
9. Repeat steps 7 and 8 for a negative 10mV source voltage by setting the calibrator voltage to -1.00000V.

Table 1-3*DC voltage measurement accuracy limits*

Model 2182 range	Calibrator voltage setting	Reading limits (1 Year, 18°C-28°C)
10mV*	10.00000mV**	9.99460 to 10.00054mV
100mV	100.0000mV	99.9966 to 100.0034mV***
1V	1.000000V	0.999973 to 1.000027V
10V	10.00000V	9.99973 to 10.00027V
100V*	100.0000V	99.9961 to 100.0039V

*Channel 1 only.

**Use 100:1 divider ratio and 1.000000V calibrator voltage.

***99.9963 to 100.0037mV for channel 2.

Temperature measurement accuracy

Follow the steps below to verify that Model 2182 temperature measurement accuracy is within specified limits. This procedure involves applying thermocouple voltages from a temperature calibrator and then verifying that Model 2182 temperature measurements are within required limits.

NOTE *If the Model 2182 meets its DC volts accuracy specifications, temperature accuracy is automatically guaranteed, and it is not necessary to verify temperature measurement accuracy. However, the following procedure is provided for those who wish to independently measure temperature measurement accuracy.*

1. With the power off, connect the temperature calibrator to the Model 2182 CHANNEL 1 input jack, as shown in [Figure 1-3](#). Connect the free ends of the thermocouple wire securely to the Model 2107 cable lugs, and observe proper polarity (thermocouple + to HI; thermocouple - to LO). Place the connections in a 0°C ice bath as shown.

Figure 1-3
Connections for temperature accuracy verification

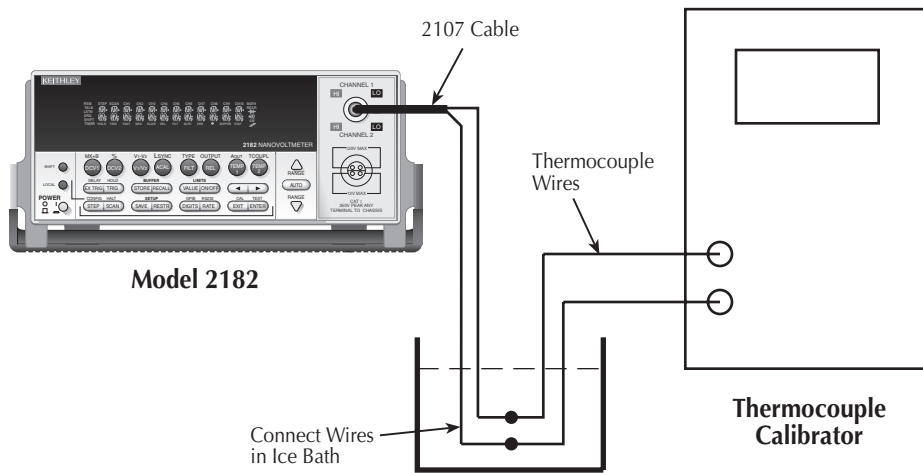

2. Turn on the power, and allow a 2-1/2 hour warm-up period.
3. Press SHIFT then TCOUPL, then use the RANGE and left and right arrow keys to select the following:
 - UNITS: C
 - JUNC: SIM, set to 0°C
 - TYPE: J
 - SENS: TCOUPLE
4. Select the Model 2182 TEMP 1 function.

5. Verify temperature measurement accuracy for each of the temperature settings listed in [Table 1-4](#). For each measurement:
 - Set the Model 2182 for the appropriate thermocouple type.
 - Set the temperature calibrator to the correct thermocouple type and temperature setting.
 - Verify that the Model 2182 temperature reading is within the limits given in the table.

Table 1-4*Temperature measurement accuracy limits*

Thermocouple type	Temperature calibrator setting (°C)	Model 2182 temperature reading limits (1 Year, 18°C-28°C)
J, K, N, T	-200	-200.2 to -199.8°C
J, K, N, T	0	-0.2 to 0.2°C
J, K, N, T	400	399.8 to 400.2°C
J, K, N	700	699.8 to 700.2°C
K, N	1300	1299.8 to 1300.2°C
E	-200	-200.2 to -199.8°C
E	0	-0.2 to 0.2°C
E	1000	999.8 to 1000.2°C
R, S	0	-0.2 to 0.2°C
R, S, B	400	399.8 to 400.2°C
R, S, B	1700	1699.8 to 1700.2°C

Analog output accuracy

Use the following procedure to verify accuracy of the analog output.

NOTE *Be sure that DC voltage measurement accuracy is within required limits before attempting this procedure.*

1. With the power off, connect the Model 2182 CHANNEL 1 input jack to the DC voltage calibrator, and connect the rear panel ANALOG output jack to the digital multimeter, as shown in [Figure 1-4](#).

Figure 1-4
Connections for analog output accuracy

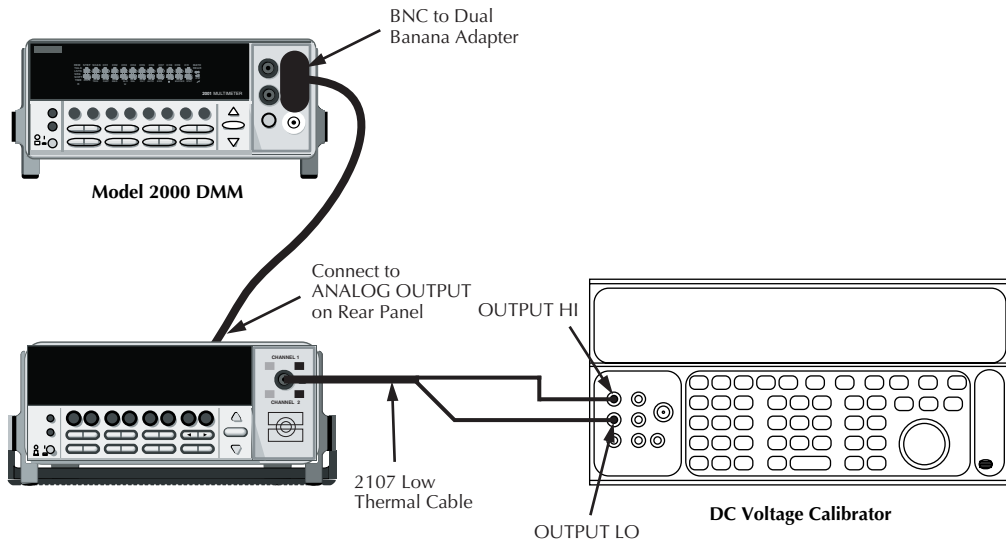

2. Select the Model 2182 DCV1 measurement function, and choose the 10V range.
3. Press SHIFT then AOUT, then use the RANGE and left and right arrow keys to set the following:
 - STATE: ON
 - M: +1.0000000
 - B: +00.000000
4. Set the calibrator voltage to 0.00000V, then enable the Model 2182 REL mode. Also enable REL on the digital multimeter.
5. Verify analog output accuracy for each of the voltages listed in [Table 1-5](#). For each test point:
 - Set the DC calibrator voltage to the indicated value.
 - Verify that the digital multimeter voltage reading is within the limits given in the table.

Table 1-5
Analog output accuracy limits

Calibrator voltage	Nominal analog output value	Analog output voltage limits
2.500000V	0.25V	0.24875 to 0.25125V
5.000000V	0.5V	0.4985 to 0.5015V
7.500000V	0.75V	0.74825 to 0.75175V
10.00000V	1V	0.998 to 1.002V

2 Calibration

Introduction

Use the procedures in this section to calibrate the Model 2182. These procedures require accurate test equipment to supply precise DC voltages. Calibration can be performed either from the front panel, or by sending SCPI calibration commands over the IEEE-488 bus or RS-232 port with the aid of a computer.

There are two general types of calibration covered in this section:

- Normal calibration: Usually the only type of calibration required in the field.
- Factory calibration: Required only if the Model 2182 has been repaired, or if a +516, “Linearity Precal Lost” error occurs.

WARNING The information in this section is intended only for qualified service personnel. Do not attempt these procedures unless you are qualified to do so. Some of these procedures may expose you to hazardous voltages.

Environmental conditions

Temperature and relative humidity

Conduct the calibration procedures at an ambient temperature of 18-28°C (65-82°F) with relative humidity of less than 70% unless otherwise noted.

Warm-up Period

Allow the Model 2182 to warm up for at least 2-1/2 hours before performing calibration.

If the instrument has been subjected to temperature extremes (those outside the ranges stated above), allow additional time for the instrument’s internal temperature to stabilize. Typically, allow one extra hour to stabilize a unit that is 10°C (18°F) outside the specified temperature range.

Also, allow the test equipment to warm up for the minimum time specified by the manufacturer.

Line Power

The Model 2182 requires a nominal line voltage of 100, 120, 220, or 240V and a line frequency of 50 to 60Hz or 400Hz. Calibration must be performed with the correct line voltage. If necessary, change the line voltage setting as covered in [Section 3](#).

Calibration considerations

When performing the calibration procedures:

- Make sure that the test equipment is properly warmed up and connected to the appropriate Model 2182 jack.
- Always allow the source signal to settle before calibrating each point.
- Use only copper-to-copper connections to minimize thermal EMFs.
- Make sure that all connections are clean and free of oxidation to avoid thermal EMFs that could affect calibration accuracy. Clean oxidation from connector terminals with DeoxIT cleaning solution.
- Keep test connections and all equipment away from drafts to avoid thermal drift.
- Do not connect test equipment to the Model 2182 through a scanner or other switching equipment.
- If an error occurs during calibration, the Model 2182 will generate an appropriate error message. See *Appendix B* for more information.

WARNING The maximum voltage between terminals to chassis ground is 350V peak. Exceeding this value may cause a breakdown in insulation, creating a shock hazard.

CAUTION The maximum voltage between CHANNEL 1 HI and LO is 120V. The maximum voltage between CHANNEL 2 HI and LO is 12V. Exceeding these voltage values may result in instrument damage.

Calibration cycle

Perform calibration every two years to ensure the unit meets or exceeds its specifications.

Calibration menu

The calibration menu allows you to access the calibration items summarized in [Table 2-1](#). To access the calibration menu, press SHIFT then CAL. Use the RANGE and left and right arrow keys to scroll through selections. Use the ENTER key to choose menu items, and use the EXIT key to cancel them.

Table 2-1
Calibrating menu

Calibration menu item	Description
CAL: DATES	Display calibration and calibration due dates.
CAL: COUNT	Display number of times unit was calibrated.
CAL: RUN	Run calibration procedure.
CAL: TEMP	Display internal calibration temperature.

Calibration dates

Choose the DATES selection in the calibration menu to display the date the Model 2182 was calibrated and the date calibration is due. The unit will display these dates as in the examples below:

DATE:12/07/97

NDUE:12/08/98

Calibration count

Choose the COUNT selection in the calibration menu to display the number of times the unit was calibrated. The instrument will display the calibration count as in this example:

COUNT: 1

Calibration temperature

Select TEMP to display the internal temperature of the unit at the time it was calibrated; for example:

TEMP: 27.61

Calibration code

Before performing calibration, you must first unlock calibration by entering or sending the calibration code as discussed below.

Front panel code

1. Access the calibration menu by pressing SHIFT CAL, and note that the instrument displays the following:

CAL: DATES

2. Use the up or down RANGE key to scroll through the available calibration menu items until the unit displays RUN, then press ENTER.
3. The Model 2182 then prompts you to enter a code:

CODE? 000000

(The factory default code is 002182.) Use the left and right arrow keys to move among the digits; use the up RANGE key to increment numbers, and press the down RANGE key to specify alphabetic letters. Confirm the code by pressing ENTER.

4. The Model 2182 allows you to define a new calibration code.

NEW CODE? N

5. Use the up and down RANGE keys to toggle between Y (yes) and N (no). Choose N if you do not want to change the code. Choose Y if you want to change the code. The unit then prompts you to enter a new code. Enter the code, and press ENTER.

Remote code

To unlock calibration via remote, send the following command:

```
:CAL:PROT:CODE '<code>'
```

For example, the following command uses the default code:

```
:CAL:PROT:CODE 'KI002182'
```

NOTE *To change the calibration code, first send the present code, then send the new code. If you change the first two characters of the password to something other than "KI", you will not be able to unlock calibration from the front panel.*

Resetting the calibration code

If you lose the calibration code, you can unlock calibration by shorting together the CAL pads, which are located on the display board. Doing so will also reset the password to the factory default (KI002182).

See [Section 5](#) for details on disassembling the unit to access the CAL pads. Refer to the display board component layout drawing at the end of [Section 6](#) for the location of the CAL pads.

Calibration errors

The Model 2182 checks for errors after each calibration step, minimizing the possibility that improper calibration may occur due to operator error.

Front panel error reporting

If an error is detected during comprehensive calibration, the instrument will display an appropriate error message (see [Appendix B](#)). The unit will then prompt you to repeat the calibration step that caused the error. If a calibration step fails, error +500 (calibration data invalid) will occur. The calibration step must be repeated.

Remote error reporting

You can detect errors while in remote by testing the state of EAV (Error Available) bit (bit 2) in the status byte. (Use the *STB? query to request the status byte.) Query the instrument for the type of error by using the :SYST:ERR? query. The Model 2182 will respond with the error number and a text message describing the nature of the error. See [Appendix B](#) for details.

Aborting calibration

You can abort the front panel calibration process at any time by pressing EXIT. The instrument will then ask you to confirm your decision to abort with the following message:

ABORT CAL?

Press EXIT to abort calibration at this point, or press any other key to return to the calibration process. Note that the Model 2182 will not respond to any remote programming commands while the ABORT CAL? message is displayed.

Normal calibration

The calibration procedures described below are generally the only instrument calibration required in the field. If, however, the Model 2182 has been repaired, the factory calibration procedures described in *Factory calibration* at the end of this section should be performed instead.

Recommended calibration equipment

Table 2-2 lists the recommended equipment for the normal calibration procedures. You can use alternate equipment as long that equipment has specifications at least four times better than equivalent Model 2182 specifications.

Table 2-2

Recommended normal calibration equipment

Description	Manufacturer/model	Specifications*
DC Calibrator	Fluke 5700A	10V: ± 5 ppm
Low Thermal Shorting Plug	Keithley 2188	
Low Thermal Input Cable	Keithley 2107	

* 90-day total uncertainty at specified output.

Front panel calibration

The procedures for front panel calibration include:

- Preparing the Model 2182 for calibration
- Front panel short and open calibration
- DC volts calibration
- Setting calibration dates and saving calibration
- Locking out calibration

Preparing the Model 2182 for calibration

1. Turn on the Model 2182, and allow it to warm up for at least 2-1/2 hours before performing the calibration procedure.
2. Start the calibration process as follows:
 - A. Access the calibration menu by pressing SHIFT then CAL.
 - B. Use the up and down RANGE keys to scroll through the available calibration menu items until the unit displays RUN, then press ENTER.
 - C. At the prompt, enter the calibration code. (The default code is 002182.) Use the left and right arrow keys to move among the digits; use the up RANGE key to increment numbers, and press the down RANGE key to specify alphabetic letters. Confirm the code by pressing ENTER.
 - D. Choose N at the prompt to proceed without changing the code, then press ENTER.

Front panel short and open calibration

1. At the start of calibration, the unit will prompt for a front panel short:

FRONT SHORT
2. Connect the Model 2188 low-thermal shorting plug to the instrument front panel input jack, as shown in [Figure 2-1](#). Wait at least three minutes before proceeding to allow for thermal equilibrium.

Figure 2-1
Low-thermal short connections

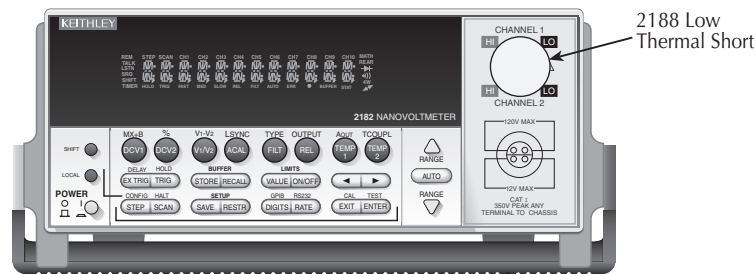

MODEL 2182

NOTE Keep drafts away from low-thermal connections to avoid thermal drift, which could affect calibration accuracy.

3. Press ENTER to start short-circuit calibration. While the unit is calibrating, it will display:

CALIBRATING

4. When the unit is done calibrating, it will display the following prompt:
REMOVE INPUT
5. Remove the low-thermal short, and press ENTER. During this phase, the CALIBRATING message will be displayed.

DC volts calibration

1. After the front panel short and open procedure, the unit will prompt you for the first DC voltage:
10.000000 V
2. Connect the calibrator to the CHANNEL 1 input of the Model 2182 using the low-thermal cable, as shown in [Figure 2-2](#). Wait two minutes to allow for thermal equilibrium before proceeding. Model 2107 cable connections are summarized in [Table 2-3](#).

Table 2-3
Input cable color codes

Input connection	Wire color
Channel 1 HI	Red
Channel 1 LO	Black
Channel 2 HI	Green
Channel 2 LO	White

Figure 2-2
Connections for DC volts calibration

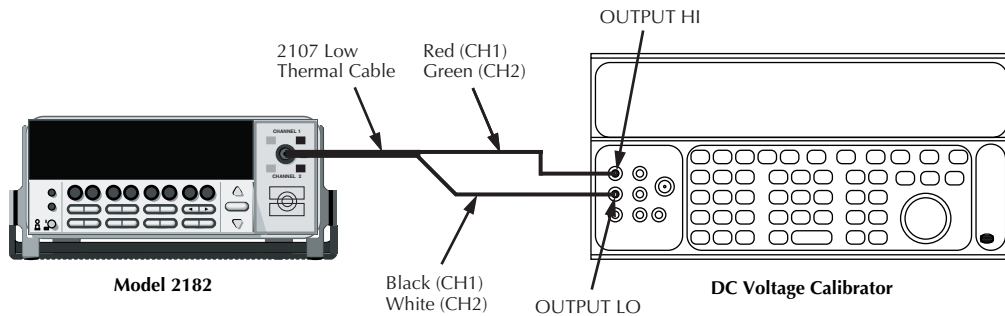

3. Set the calibrator to output DC volts, and turn external sense off.
4. Perform the steps listed in [Table 2-4](#) to complete DC volts calibration. For each calibration step:
 - Set the calibrator to the indicated value, and make sure it is in operate.
 - Wait for the signal voltage to settle.
 - Press the ENTER key to calibrate that step.
 - Wait until the Model 2182 finishes each step. (The unit will display the CALIBRATING message while calibrating.)

NOTE Lock calibrator to the 11V range. If your calibrator cannot output the values recommended in [Table 2-4](#), use the left and right arrow keys, and the up and down RANGE keys to set the Model 2182 display value to match the calibrator output voltage.

Table 2-4
DC volts front panel calibration summary

Calibration step	Calibrator voltage*	Allowable range
10.000000 V	+10.000000V	+9V to +11V
-10.000000 V	-10.000000V	-9V to -11V

* Use indicated values when possible.

Setting dates and saving calibration

At the end of the calibration procedure, the instrument will display the CALIBRATION COMPLETE message. Press ENTER to continue, and the Model 2182 will prompt you to enter the calibration date and the calibration due date. Set these dates as follows:

1. At the CAL DATE: mm/dd/yy prompt, use the left and right arrow keys, and the RANGE keys to set the calibration date, then press ENTER.
2. The unit will then prompt you to enter the next calibration due date with this prompt: CAL NDUE: mm/dd/yy. Use the left and right arrow keys, and the RANGE keys to set the calibration due date, then press ENTER.
3. The unit will prompt you to save new calibration constants with this message: SAVE CAL? YES. To save the new constants, press ENTER. If you do not want to save the new constants, press the down range key to toggle to NO, then press ENTER.

NOTE Calibration constants calculated during the current calibration procedure will not be saved unless you choose the YES option. Previous calibration constants will be retained if you select NO.

Remote calibration

Follow the steps in this section to perform calibration via remote. See *Appendix B* for a detailed list and description of SCPI calibration commands.

When sending calibration commands, be sure that the Model 2182 completes each step before sending the next command. You can do so either by observing the front panel CALIBRATING message, or by detecting the completion of each step over the bus. Be sure to include a space character between each command and parameter.

The procedures for calibrating the Model 2182 using SCPI commands include:

- Preparing the Model 2182 for calibration
- Front panel short and open calibration
- DC volts calibration
- Programming calibration dates
- Saving calibration constants
- Locking out calibration

Preparing the Model 2182 for calibration

1. Connect the Model 2182 to the IEEE-488 bus of the computer using a shielded IEEE-488 cable, such as the Keithley Model 7007, or connect the unit to a computer through the RS-232 port using a straight-through 9-pin to 9-pin cable (use a 9 to 25-pin adapter if necessary).
2. Turn on the Model 2182, and allow it to warm up for 2-1/2 hours before performing calibration.
3. Select the DCV1 function.
4. Make sure the primary address of the Model 2182 is the same as the address specified in the program that you will be using to send commands. (Use the GPIB key.)
5. Unlock the calibration function by sending this command:

```
:CAL:PROT:CODE 'KI002182'
```

(The above command shows the default code, KI002182. Substitute the correct code if changed.)

6. Send the following command to initiate calibration:

```
:CAL:PROT:INIT
```

Short and open calibration

1. Connect the Model 2188 low-thermal shorting plug to the instrument input jack, as shown in [Figure 2-1](#). Wait at least two minutes before proceeding to allow for thermal equilibrium.

NOTE *Keep drafts away from low-thermal connections to avoid thermal drift, which could affect calibration accuracy.*

2. Send the following command:
:CAL:PROT:DC:STEP1
3. After the Model 2182 completes this step, remove the low-thermal short, and send this command:
:CAL:PROT:DC:STEP2

DC volts calibration

After front panel short and open steps, do the following:

1. Connect the calibrator to the CHANNEL 1 input of the Model 2182 as shown in [Figure 2-2](#). (See [Table 2-3](#) for wire colors.) Allow two minutes for thermal equilibrium.
2. Perform the calibration steps summarized in [Table 2-5](#). For each step:
 - Set the calibrator to the indicated voltage, and make sure the unit is in operate. (Use the recommended voltage whenever possible.)
 - Allow the signal voltage to settle.
 - Send the indicated programming command. (Change the voltage parameter if you are using a different calibration voltage.)
 - Wait until the Model 2182 completes each step before continuing.

Table 2-5
DC voltage remote calibration programming steps

Calibration step	Calibrator voltage	Calibration command*	Parameter range
+10V	+10.000000V	:CAL:PROT:DC:STEP3 10	9 to 11
-10V	-10.000000V	:CAL:PROT:DC:STEP4 -10	-9 to -11

* Use indicated values whenever possible. Change parameter accordingly if using a different calibrator voltage.

Programming calibration dates

Program the present calibration date and calibration due date by sending the following commands:

```
:CAL:PROT:DATE <year>, <month>, <day>
:CAL:PROT:NDUE <year>, <month>, <day>
```

For example, the following commands assume calibration dates of 12/15/97 and 12/15/98 respectively:

```
:CAL:PROT:DATE 1997, 12, 15
:CAL:PROT:NDUE 1997, 12, 15
```

Saving calibration constants

After completing the calibration procedure, send the following command to save the new calibration constants:

```
:CAL:PROT:SAVE
```

NOTE Calibration constants will not be saved unless the `:SAVE` command is sent.

Calibration constants can be returned using the `:CAL:PROT:DATA?` command. For details, see “Miscellaneous commands, `:DATA?`” in Appendix B.

Default calibration constants and tolerances are listed in [Appendix B](#) (see [Table B-2](#)).

Locking out calibration

After saving calibration, send the following command to lock out calibration:

```
:CAL:PROT:LOCK
```

Factory calibration

The following calibration procedures are normally performed only at the factory, but the necessary steps are included here in case the unit is repaired (such as changing internal components), and the unit requires these calibration procedures. The unit will also require factory calibration if a +516, “Linearity Precal Lost” error occurs.

Recommended test equipment

[Table 2-6](#) summarizes the test equipment recommended for the manufacturing calibration steps.

Table 2-6

Recommended factory calibration equipment

Description	Manufacturer/model	Specifications*
DC Calibrator	Fluke 5700A	1V: ± 7 ppm 10V: ± 5 ppm
Low Thermal Input Cable	Keithley 2107	
Low Thermal Short	Keithley 2188	
BNC-to-Clip Leads		

* 90-day total uncertainty at specified output.

Remote factory calibration

Follow the steps in this section to perform factory calibration via remote. See [Appendix B](#) for a detailed list and description of SCPI calibration commands.

When sending calibration commands, be sure that the Model 2182 completes each step before sending the next command. You can do so either by observing the front panel PRECAL or CALIBRATING message, or by detecting the completion of each step over the bus. Be sure to include a space character between each command and parameter.

The procedures for factory calibrating the Model 2182 using SCPI commands include:

- Preparing the Model 2182 for factory calibration
- Precalibration
- Front panel short and open calibration
- DC volts calibration
- Analog output calibration
- Programming calibration dates
- Saving calibration constants
- Locking out calibration

Preparing the Model 2182 for factory calibration

1. Connect the Model 2182 to the IEEE-488 bus of the computer using a shielded IEEE-488 cable, such as the Keithley Model 7007, or connect the unit to a computer through the RS-232 port using a straight-through 9-pin to 9-pin cable (use a 9-25-pin adapter if necessary).
2. Press in and hold the STEP key, then turn on the Model 2182, and allow it to warm up for 2-1/2 hours before performing calibration.
3. Select the DCV1 function.
4. Make sure the primary address of the Model 2182 is the same as the address specified in the program that you will be using to send commands. (Use the GPIB key.)
5. Unlock the calibration function by sending these commands:

```
:DIAG:KEIT:CAL:UNLOCK  
:CAL:PROT:CODE 'K1002182'
```

(The above command shows the default code, KI002182. Substitute the correct code if changed.)

6. Send the following command to initiate calibration:

```
:CAL:PROT:INIT
```

Precalibration

1. Connect the calibrator to CHANNEL 1 of the Model 2182 input jack using the low-thermal cable, as shown in [Figure 2-3](#). Wait two minutes to allow for thermal equilibrium before proceeding. (See [Table 2-3](#) for Model 2107 cable connections.)
2. Set the calibrator to output DC volts, and turn external sense off.

Figure 2-3

Connections for factory DC volts calibration

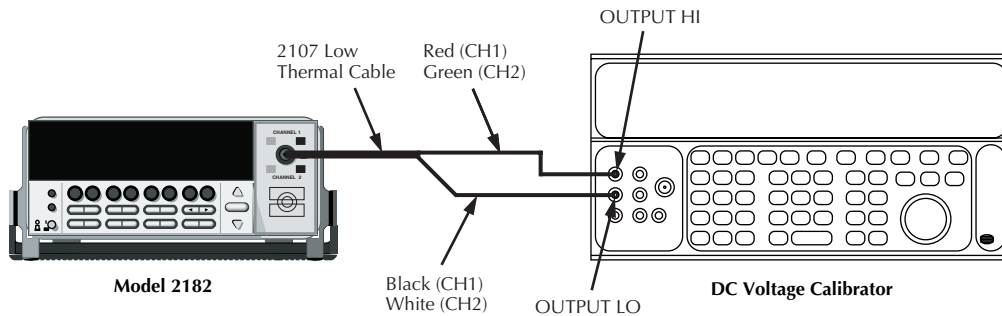

NOTE Keep drafts away from low-thermal connections to avoid thermal drift, which could affect calibration accuracy.

3. Perform the precalibration steps summarized in [Table 2-7](#). For each step:
 - Set the calibrator to the indicated voltage, and make sure the unit is in operate.
 - Allow the signal voltage to settle.
 - Send the indicated programming command.
 - Wait until the Model 2182 completes each step before continuing.

Table 2-7

Remote precalibration steps

Precalibration step	Calibrator voltage	Calibration command
10V	10.000000V	:CAL:PROT:PCAL:STEP0 10
0V	0.000000V	:CAL:PROT:PCAL:STEP1 0
1V	1.000000V	:CAL:PROT:PCAL:STEP2 1

NOTE Keep the calibrator locked to the 11V range.

Short and open calibration

1. Connect the Model 2188 low-thermal shorting plug to the instrument input jack, as shown in [Figure 2-4](#). Wait at least three minutes before proceeding to allow for thermal equilibrium.
2. Send the following command:
:CAL:PROT:DC:STEP1
3. After the Model 2182 completes this step, remove the low-thermal short, and send this command:
:CAL:PROT:DC:STEP2

Figure 2-4
Low thermal short connections for factory calibration

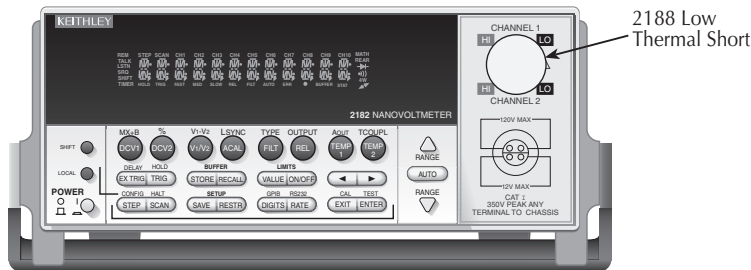

DC volts calibration

After front panel short and open steps, do the following:

1. Connect the calibrator to the Model 2182 as shown in [Figure 2-3](#). Allow two minutes for thermal equilibrium.
2. Perform the calibration steps summarized in [Table 2-8](#). For each step:
 - Set the calibrator to the indicated voltage, and make sure the unit is in operate. (Use the recommended voltage if possible.)
 - Allow the signal voltage to settle.
 - Send the indicated programming command. (Change the voltage parameter if you are using a different calibration voltage.)
 - Wait until the Model 2182 completes each step before continuing.

Table 2-8
DC voltage remote calibration programming steps

Calibration step	Calibrator voltage	Calibration command*	Parameter range
+10V	+10.000000V	:CAL:PROT:DC:STEP3 10	9 to 11
-10V	-10.000000V	:CAL:PROT:DC:STEP4 -10	-9 to -11

* Change parameter accordingly if using a different calibrator voltage.

Analog output calibration

1. Connect the Model 2182 analog output to CHANNEL 1 of the front panel input jack, as shown in [Figure 2-5](#).
2. Send the following command to calibrate the analog output:

```
:CAL:PROT:DC:STEP5
```

Figure 2-5

Connections for analog output calibration

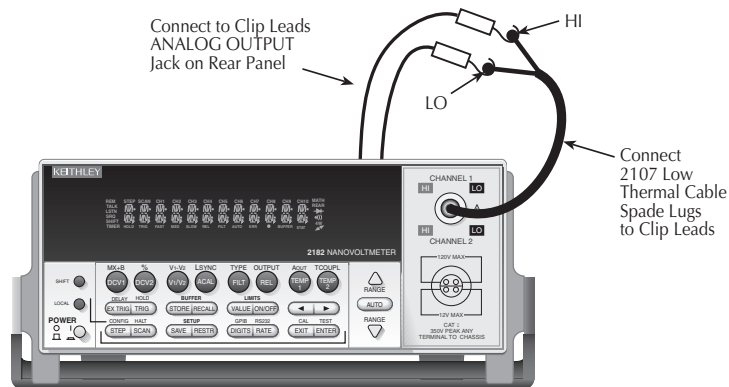

MODEL 2182

Programming calibration dates

Program the present calibration date and calibration due date by sending the following commands:

```
:CAL:PROT:DATE <year>, <month>, <day>  
:CAL:PROT:NDUE <year>, <month>, <day>
```

For example, the following commands assume calibration dates of 12/15/97 and 12/15/98 respectively:

```
:CAL:PROT:DATE 1997, 12, 15  
:CAL:PROT:NDUE 1998, 12, 15
```

Saving calibration constants

After completing the calibration procedure, send the following command to save the new calibration constants:

```
:CAL:PROT:SAVE
```

NOTE Calibration constants will not be saved unless the `:SAVE` command is sent.

Calibration constants can be returned using the `:CAL:PROT:DATA?` command. For details, see “Miscellaneous commands, `:DATA?`” in Appendix B.

Default calibration constants and tolerances are listed in Appendix B (see Table B-2).

Locking out calibration

After saving calibration, send the following command to lock out calibration:

```
:CAL:PROT:LOCK
```

3 Routine Maintenance

Introduction

The information in this section deals with routine type maintenance that can be performed by the operator.

Line fuse replacement

WARNING Disconnect the line cord at the rear panel, and remove all test leads and cables connected to the instrument (front and rear) before replacing the line fuse.

The power line fuse is accessible from the rear panel, just adjacent to the AC power receptacle in the power module (see [Figure 3-1](#)).

Figure 3-1
Line fuse replacement

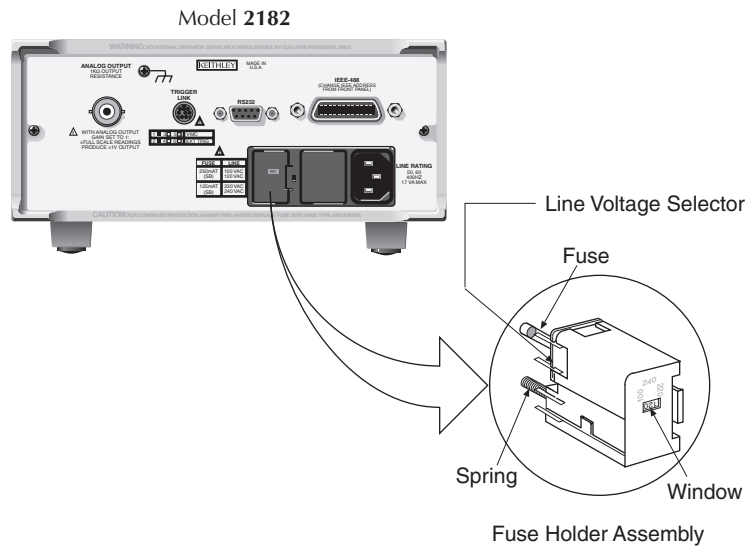

Perform the following steps to replace the line fuse:

1. Carefully pry the locking tab that secures the fuse carrier to the power module.
2. Pull out the fuse carrier, and replace the fuse with the type specified in [Table 3-1](#).

CAUTION To prevent instrument damage, use only the fuse type specified in [Table 3-1](#).

3. Re-install the fuse carrier.

NOTE *If the power line fuse continues to blow, a circuit malfunction exists and must be corrected. Refer to the troubleshooting section of this manual for additional information.*

Table 3-1
Power line fuse ratings

Line voltage	Rating	Keithley part no.
100-120V	250V, 0.25A, Slow Blow 5 X 20mm	FU-96-4
200-240V	250V, 0.125A, Slow Blow 5 X 20mm	FU-91

Line voltage selection

WARNING Disconnect the line cord at the rear panel, and remove all test leads and cables connected to the instrument (front and rear) before changing the line voltage.

The Model 2182 can be set to operate on either 100V, 120V, 220V, or 240V nominal line voltages. You can change the line voltage as follows:

1. Carefully pry the locking tab that secures the fuse carrier to the power module.
2. Pull out the fuse holder from the carrier.
3. If you are changing the line voltage that requires a different fuse, replace it with the correct type. (See [Table 3-1](#)).
4. Rotate the fuse holder so that the desired line voltage setting will be displayed in the small window in the carrier, then install the holder in the carrier.
5. Install the fuse carrier in the power module, and make sure the locking tab secures it properly.

Troubleshooting⁴

Introduction

This section of the manual will assist you in troubleshooting and repairing the Model 2182. Included are self-tests, test procedures, troubleshooting tables, and circuit descriptions. Note that disassembly instructions are located in [Section 5](#), while component layout drawings may be found at the end of [Section 6](#).

WARNING The information in this section is intended only for qualified service personnel. Do not perform these procedures unless you are qualified to do so. Some of these procedures may expose you to hazardous voltages that could cause personal injury or death. Use caution when working with hazardous voltages.

Repair considerations

Before making any repairs to the Model 2182, be sure to read the following considerations.

CAUTION The PC-boards are built using surface mount techniques and require specialized equipment and skills for repair. If you are not equipped and/or qualified, it is strongly recommended that you send the unit back to the factory for repairs or limit repairs to the PC-board replacement level. Without proper equipment and training, you could damage a PC-board beyond repair.

- Repairs will require various degrees of disassembly. However, it is recommended that the Front Panel Tests be performed prior to any disassembly. The disassembly instructions for the Model 2182 are contained in [Section 5](#) of this manual.
- Do not make repairs to surface mount PC-boards unless equipped and qualified to do so (see previous CAUTION).
- When working inside the unit and replacing parts, be sure to adhere to the handling precautions and cleaning procedures explained in [Section 5](#).
- Many CMOS devices are installed in the Model 2182. These static-sensitive devices require special handling as explained in [Section 5](#).
- Whenever a circuit board is removed or a component is replaced, the Model 2182 must be recalibrated. See [Section 2](#) for details on calibrating the unit.

Power-on self-test

During the power-on sequence, the Model 2182 will perform a checksum test on its EPROM and test its RAM. If one of these tests fails, the instrument will lock up.

Front panel tests

There are two front panel tests: one to test the functionality of the front panel keys and one to test the display. In the event of a test failure, refer to [“Display board checks” on page 4-10](#) for details on troubleshooting the display board.

KEY test

The KEY test allows you to check the functionality of each front panel key. Perform the following steps to run the KEY test:

1. Press SHIFT and then TEST to access the self-test options.
2. Use the up or down RANGE key to display “TEST: KEY”.
3. Press ENTER to start the test. When a key is pressed, the label name for that key is displayed to indicate that it is functioning properly. When the key is released, the message “NO KEY PRESS” is displayed.
4. Pressing EXIT tests the EXIT key. However, the second consecutive press of EXIT aborts the test and returns the instrument to normal operation.

DISP test

The display test allows you to verify that each segment and annunciator in the vacuum fluorescent display is working properly. Perform the following steps to run the display test:

1. Press SHIFT and then TEST to access the self-test options.
2. Use the up or down RANGE key to display “TEST: DISP”.
3. Press ENTER to start the test. There are four parts to the display test. Each time ENTER is pressed, the next part of the test sequence is selected. The four parts of the test sequence are as follows:
 - All annunciators are displayed.
 - The segments of each digit are sequentially displayed.
 - The 12 digits (and annunciators) are sequentially displayed.
 - The annunciators located at either end of the display are sequentially displayed.
4. When finished, abort the display test by pressing EXIT. The instrument returns to normal operation.

Principles of operation

The following information is provided to support the troubleshooting tests and procedures covered in this section of the manual. Refer to the following block diagrams:

- Figure 4-1 — Power supply block diagram
- Figure 4-2 — Digital circuitry block diagram
- Figure 4-3 — Simplified schematic of analog circuitry

Power supply

The following information provides some basic circuit theory that can be used as an aid to troubleshoot the power supply. A block diagram of the power supply is shown in [Figure 4-1](#).

Figure 4-1
Power supply block diagram

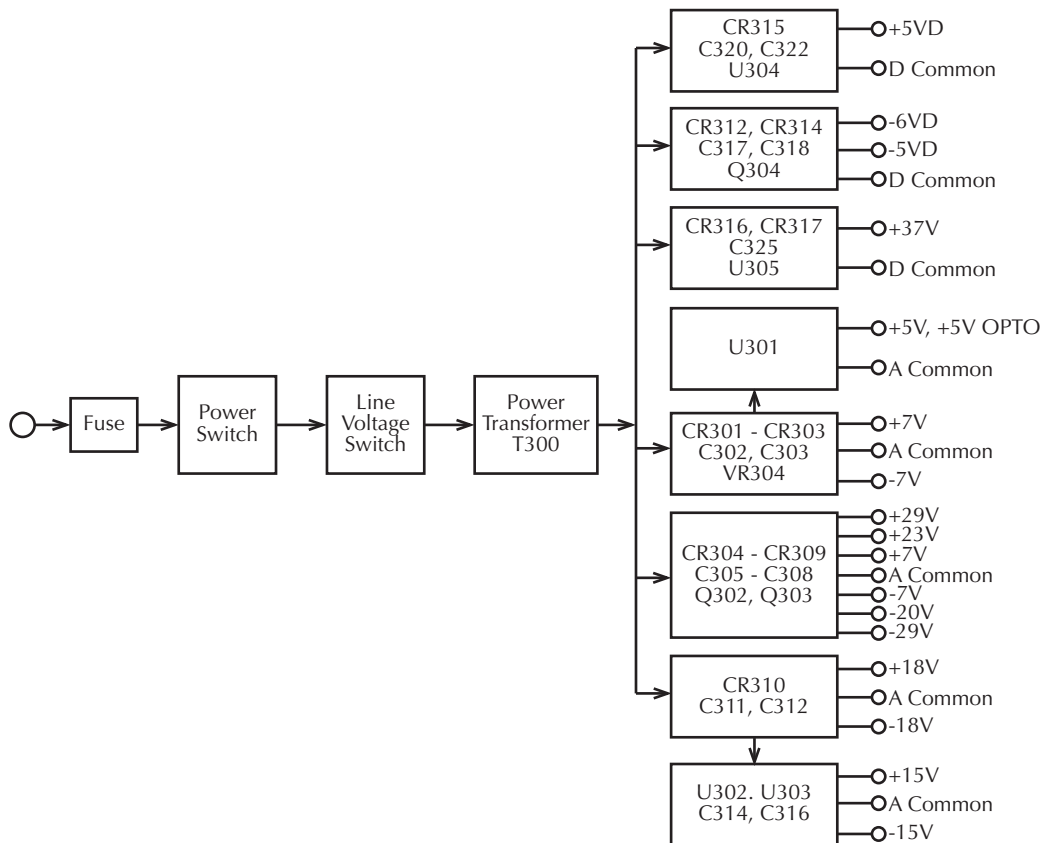

AC power is applied to the AC power module receptacle. Power is routed through the line fuse and line voltage selection switch of the power module to the power transformer. The power transformer has several secondary windings for the various supplies.

AC voltage for the display filaments is taken from a power transformer secondary at F1 and F2, and then routed to the display board.

Each DC supply uses a rectifier and a capacitive filter, and many supplies use an IC regulator or transistors. The various components are shown in [Figure 4-1](#).

Display board

Display board components are shown in the digital circuitry block diagram in [Figure 4-2](#).

Figure 4-2
Digital circuitry block diagram

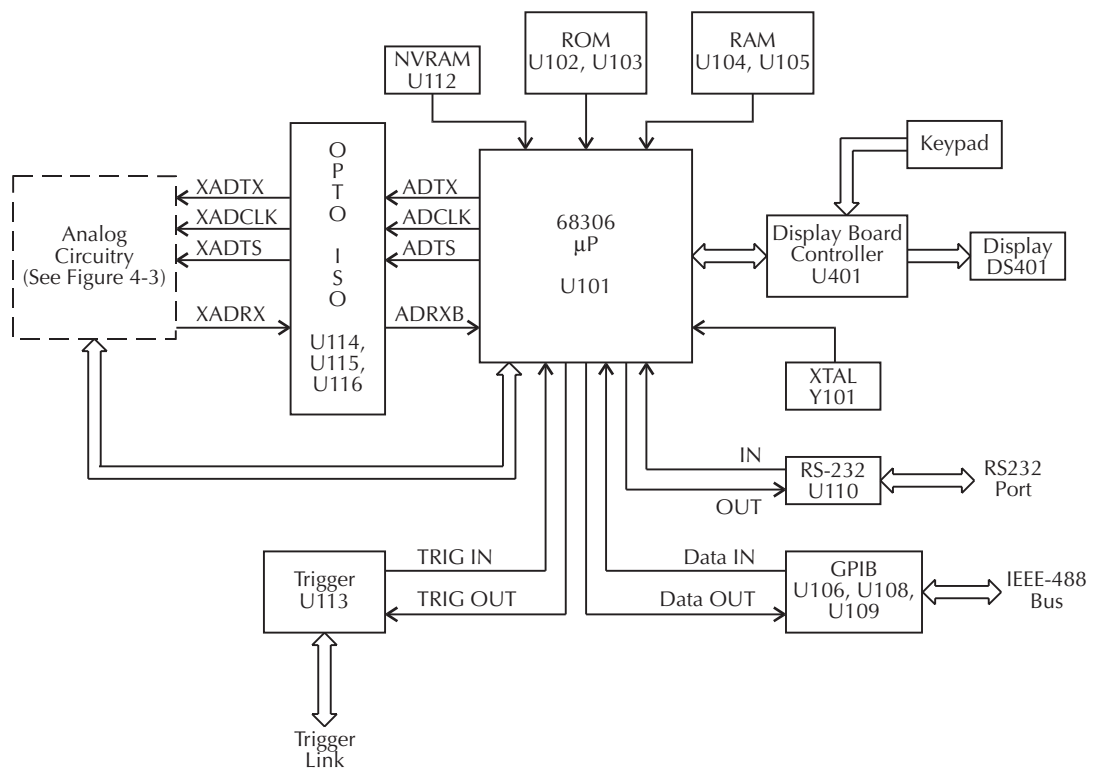

Microcontroller

U401 is the display board microcontroller that controls the display and interprets key data. The microcontroller uses three internal peripheral I/O ports for the various control and read functions.

Display data is serially transmitted to the microcontroller from the digital section via the TXB line to the microcontroller RDI terminal. In a similar manner, key data is serially sent back to the digital section through the RXB line via TDO. The 4MHz clock for the microcontroller is generated by crystal Y401.

Display

DS401 is the display module, which can display up to 12 alpha-numeric characters and includes the various annunciators.

The display uses a common multiplexing scheme with each character refreshed in sequence. U402 and U403 are the drivers for the display characters and annunciators. Note that data for the drivers are serially transmitted from the microcontroller (MOSI and PC1).

Filament voltage for the display is derived from the power supply transformer (F1 and F2). The display drivers require +37VDC and +5VDC, which are supplied by U304 (+5VD) and U305 (+37V).

Key matrix

The front panel keys (S401-S430) are organized into a row-column matrix to minimize the number of microcontroller peripheral lines required to read the keyboard. A key is read by strobing the columns and reading all rows for each strobed column. Key-down data is interpreted by the display microcontroller and sent back to the main microprocessor using proprietary encoding schemes.

Digital circuitry

Refer to [Figure 4-2](#) for the following discussion on digital circuitry.

Microprocessor

U101 is a 68306 microprocessor that oversees all operating aspects of the instrument. The MPU has a 16-bit data bus and provides an 18-bit address bus. It also has parallel and serial ports for controlling various circuits. For example, the RXDA, TXDA, RXDB and TXDB lines are used for the RS-232 interface.

The MPU clock frequency of 14.7456MHz is controlled by crystal Y101. MPU RESET is performed momentarily (through C133) on power-up by the +5VD1 power supply.

Memory circuits

ROMs U102 and U103 store the firmware code for instrument operation. U103 stores the D0-D7 bits of each data word, and U103 stores the D8-D15 bits.

RAMs U104 and U105 provide temporary operating storage. U104 stores the D0-D7 bits of each data word, and U105 stores the D8-D15 bits.

Semi-permanent storage facilities include NVRAM U112. This IC stores such information as instrument setup and calibration constants. Data transmission from this device is done in a serial fashion.

RS-232 interface

Serial data transmission and reception is performed by the TXDB and RXDB lines of the MPU. U110 provides the necessary voltage level conversion for the RS-232 interface port.

IEEE-488 interface

U106, U108 and U109 make up the IEEE-488 interface. U106, a 9914A GPIA, takes care of routine bus overhead such as handshaking, while U108 and U109 provide the necessary buffering and drive capabilities for the data, control, and handshake lines.

Trigger circuits

Buffering for Trigger Link input and output is performed by U113. Trigger input and output is controlled by the IRQ4 and PB3 lines of the MPU.

At the factory, trigger output is connected to line 1 of the Trigger Link connector (resistor R145 installed). Trigger input is connected to line 2 of the Trigger Link connector (resistor R142 installed).

Analog circuitry

Refer to [Figure 4-3](#) for the following discussion of analog circuitry.

Figure 4-3
Simplified schematic of analog circuitry

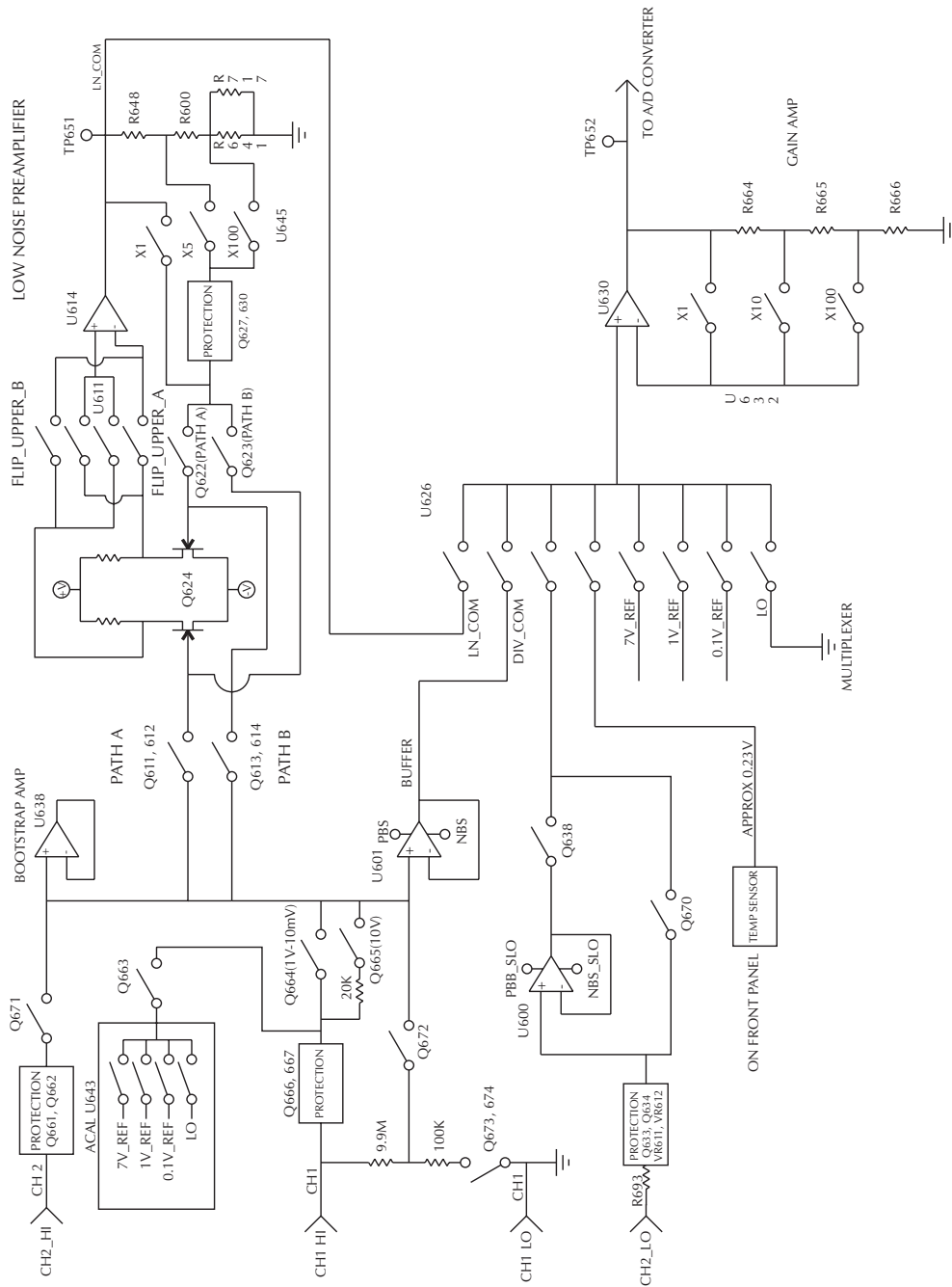

Input signal conditioning

Protection circuits

The CH1 HI, CH2 HI, and CH2 LO inputs have protection circuits designed to prevent circuit damage from over-voltage signal conditions. Q666 and Q667 provide protection for CH1 HI, while Q661 and Q662 provide similar protection for CH2 HI.

Signal paths

There are two basic signal paths: DIV_COM (divider common) and LN_COM (low noise common). The divider common path has an attenuation factor of 100:1, and is used for the 100V range, while the low-noise preamplifier is used for the 10mV-10V ranges.

Buffering

U601 is a unity-gain amplifier that provides signal buffering for the divider common signal path. A 100:1 resistive divider is switched in to attenuate the signal for the 100V range.

Low-noise preamplifier

The low-noise preamplifier is made up of Q624, U614, and associated components. Q624 and U614 form a composite op amp with switchable gain depending on the selected measurement function. Q624 forms the differential amplifier input, while U614 provides the required high open-loop gain. Circuit gain is controlled through feedback elements and signal paths by switches Q611-Q614, Q622, Q623, and U645.

Multiplexer and gain amplifier

Multiplexer

U626 is the multiplexer that switches among a number of signals during the various phases of the measurement cycle. In addition to the two main signal paths, DIV_COM and LN_COM, the mux also switches input LO, CH2 LO, the front panel temperature sensor, as well as the 7V, 1V, and 0.1V reference signals. The two LO signals are measured to null offsets, the temperature sensor is measured for temperature measurements and TCAL, and the reference voltages provide stable comparison voltages for accurate measurements.

Gain amplifier

U630, Q651, and associated components are gain amplifiers that provide X1, X10, or X100 gain factors, depending on the selected range. Gain is controlled by switching in various resistors into the feedback loop. Note that the output of U630 is the signal that is applied to the A/D converter for conversion into digital data that can be read by the microprocessor.

Circuit gain

Table 4-1 summarizes the circuit gain factors for the various ranges.

Table 4-1

Circuit gain factors

Range	Divider attenuation	Preamp gain	Multiplexer gain
100V	100:1	N/A	X10
10V	N/A	X1	X1
1V	N/A	X1	X10
100mV	N/A	X1	X100
10mV	NA	X100	X10

Troubleshooting

Troubleshooting information for the various circuits is summarized below. Use the “Principles of operation” on page 4-4 and the component layouts at the end of Section 6 as aids in troubleshooting.

Display board checks

If the front panel DISP test indicates that there is a problem on the display board, use Table 4-2.

Table 4-2

Display board checks

Step	Item/component	Required condition	Remarks
1	Front panel DISP test.	Verify that all segments operate.	Use front panel display test.
2	P1005, pin 5	+5V +/-5%	Digital +5V supply.
3	P1005, pin 9	+37V +/-5%	Display +37V supply.
4	U401, pin 1	Goes low briefly on power up, then goes high.	Microcontroller RESET.
5	U401, pin 43	4MHz square wave.	Controller 4MHz clock.
6	U401, pin 32	Pulse train every 1msec.	Control from main processor.
7	U401, pin 33	Brief pulse train when front panel key is pressed.	Key down data sent to main processor.

Power supply checks

Power supply problems can be checked out using [Table 4-3](#).

Table 4-3
Power supply checks

Step	Item/component	Required condition	Remarks
1	Line fuse	Check continuity.	Remove to check.
2	Line voltage	120V/240V as required.	Check power module position.
3	Line power	Plugged into live receptacle, power on.	Check for correct power-up sequence.
4	U304, pin 2	+5V $\pm 5\%$	+5VD, referenced to TP301.
5	U305, pin 2	+37V $\pm 5\%$	+37V, referenced to TP301.
6	CR313 anode	-6V $\pm 20\%$	-6VD, referenced to TP301.
7	Q304, pin 2	-5V, $\pm 5\%$	-5VD, referenced to TP301.
8	U302, pin 3	+15V $\pm 5\%$	+15V, referenced to TP303.
9	U303, pin 3	-15V $\pm 5\%$	-15V, referenced to TP303.
10	U301, pin 3	+5V $\pm 5\%$	+5V, referenced to TP303.
11	CR305 cathode	+29V $\pm 20\%$	+29V, referenced to TP303.
12	CR309 anode	-29V $\pm 20\%$	-29V, referenced to TP303.
13	CR310 V+, pin 1	+18V $\pm 20\%$	+18V, referenced to TP303.
14	CR310 V-, pin 2	-18V $\pm 20\%$	-18V, referenced to TP303.
15	CR306 anode	-7V $\pm 20\%$	-7V, reference to TP303.
16	CR308 cathode	+7V $\pm 5\%$	+7V, referenced to TP303.

Digital circuit checks

Digital circuit problems can be checked out using [Table 4-4](#).

Table 4-4
Digital circuit checks

Step	Item/component	Required condition	Remarks
1	Power-on test	RAM OK, ROM OK.	Verify that RAM and ROM are functional.
2	TP301	Digital common.	All signals referenced to digital common.
3	U103 pin 32	+5V	Digital logic supply.
4	U101 pin 48	Low on power-up, then goes high.	MPU RESET line.
5	U101, lines A1-A18	Check for stuck bits.	MPU address bus.
6	U101, lines D0-D15	Check for stuck bits.	MPU data bus.
7	U101 pin 44	14.7456MHz	MPU clock.
8	U110 pin 13	Pulse train during RS-232 I/O.	RS-232 RX line.
9	U110 pin 14	Pulse train during RS-232 I/O.	RS-232 TX line.
10	U106 pins 34-42	Pulse train during IEEE-488 I/O.	IEEE-488 data bus.
11	U106 pins 26-31	Pulses during IEEE-488 I/O.	IEEE-488 command lines.
12	U106 pin 24	Low with remote enabled.	IEEE-488 REN line.
13	U106 pin 25	Low during interface clear.	IEEE-488 IFC line.
14	U101 pin 84	Pulse train.	ADRXB
15	U101 pin 91	Pulse train.	ADTX
16	U101 pin 90	Pulse train.	ADCLK
17	U101 pin 89	Pulse train.	ADTS

Analog circuit checks

Table 4-5 summarizes checks for the analog circuits. These tests involve applying specific test voltages to the channel 1 input terminals and measuring voltages at the indicated test points. See Figure 1-1 in Section 1 for DC voltage input test connection.

Table 4-5
Analog circuit checks

Step	Item/component	Required condition	Remarks
1	Function	DCV1	Use DCV1 for measurements.
2	Input connections	CH1 HI and LO	Connect voltage source to CH1.
3	Measurement range	100V	Select 100V range.
4	Input voltage	100V	Apply 100V to CH1 input.
5	U601 pin 6	+1V	Buffer output.
6	TP652	+10V	Multiplexer output to A/D.
7	Measurement range	10V	Select 10V range.
8	Input voltage	+10V	Apply 10V to CH1 input.
9	TP651	+10V	Preamp output.
10	TP652	+10V	Multiplexer output to A/D.
11	Measurement range	1V	Select 1V range.
12	Input voltage	+1V	Apply 1V to CH1 input.
13	TP651	+1V	Preamp output.
14	TP652	+10V	Multiplexer output to A/D.
15	Measurement range	100mV	Select 100mV range.
16	Input voltage	+100mV	Apply 100mV to CH1 input.
17	TP651	+100mV	Preamp output.
18	TP652	+10V	Multiplexer output to A/D.
19	Measurement range	10mV	Select 10mV range.
20	Input voltage	+10mV	Apply 10mV to CH1 input.
21	TP651	+1V	Preamp output.
22	TP652	+10V	Multiplexer output to A/D.

Notes: 1. Before testing, disable autozero by sending the following command over the remote interface:

```
:SYST:AZERO:STAT OFF.
```

2. All voltage measurements referenced to TP303.

Analog signal switching states

Table 4-6 and Table 4-7 provide switching states of the various ICs and transistors for the basic measurement functions and ranges. These tables can be used to assist in tracing an analog signal from the channel 1 and channel 2 inputs to the A/D multiplexer.

Table 4-6
Signal multiplexing gain switching

Function and Range	U626 (Signal)	U632 Pin 1	U632 Pin 8	U632 Pin 9	Gain
DCV1:					
10mV	S4	Off	Off	On	X10
100mV	S4	Off	On	Off	X100
1V	S4	Off	Off	On	X10
10V	S4	On	Off	Off	X1
100V	S3	Off	Off	On	X10
DCV2:					
100mV	S4, S7	Off	On	Off	X100
1V	S4, S7	Off	Off	On	X10
10V	S4, S7	On	Off	Off	X1
DCV2 (LQ MODE ON)*					
100mV	S3, S7	Off	On	Off	X100
1V	S3, S7	Off	Off	On	X10
10V	S3, S7	On	Off	Off	X1

*Send the following remote command to enable. :SENS:VOLT:CHAN2:LQM ON.

Table 4-7

Input protection and low-noise preamplifier analog switching states

Function and Range	Q666	Q667	Q664	Q665	Q672	Q673	Q674	U645 Pin 1, 16	U645 Pin 8	U645 Pin 9
DCV1:										
10mV	On	On	On	On	Off	Off	Off	On	Off	Off
100mV	On	On	On	On	Off	Off	Off	Off	Off	On
1V	On	On	On	On	Off	Off	Off	Off	Off	On
10V	On	On	Off	On	Off	Off	Off	Off	Off	On
100V	Off	Off	Off	Off	On	On	On	Off	Off	On
DCV2:	Q661	Q662	Q671							
100mV	On	On	On					Off	Off	On
1V	On	On	On					Off	Off	On
10V	On	On	On					Off	Off	On

No comm link error

A “No Comm Link” error indicates that the front panel processor has stopped communicating with the main processor, which is located on the motherboard. This error indicates that one of the main processor ROMs may require re-seating in its socket. ROMs may be resealed as follows:

1. Turn off the power, and disconnect the line cord and all other test leads and cables from the instrument.
2. Remove the case cover as outlined in [Section 5](#).
3. Locate the two firmware ROMs, U102 and U103, located on the motherboard. These are the only ICs installed in sockets. (Refer to the component layout drawing at the end of [Section 6](#) for exact locations.)
4. Carefully push down on each ROM IC to make sure it is properly seated in its socket.

CAUTION Be careful not to push down excessively, or you might crack the motherboard.

5. Connect the line cord, and turn on the power. If the problem persists, additional troubleshooting will be required.

5 Disassembly

Introduction

This section explains how to handle, clean, and disassemble the Model 2182. Disassembly drawings are located at the end of this section.

Handling and cleaning

To avoid contaminating PC board traces with body oil or other foreign matter, avoid touching the PC board traces while you are repairing the instrument. Some board areas have high-impedance devices or sensitive circuitry where contamination could cause degraded performance.

Handling PC boards

Observe the following precautions when handling PC boards:

- Wear cotton gloves.
- Handle PC boards only by the edges and shields.
- Do not touch any board traces or components not associated with repair.
- Do not touch areas adjacent to electrical contacts.
- Use dry nitrogen gas to clean dust off PC boards.

Solder repairs

Observe the following precautions when soldering a circuit board:

- Use an OA-based (organic activated) flux, and take care not to spread the flux to other areas of the circuit board.
- Remove the flux from the work area when you have finished the repair by using pure water with clean, foam-tipped swabs or a clean, soft brush.
- Once you have removed the flux, swab only the repair area with methanol, then blow dry the board with dry nitrogen gas.
- After cleaning, allow the board to dry in a 50°C, low-humidity environment for several hours.

Static sensitive devices

CMOS devices operate at very high impedance levels. Therefore, any static that builds up on you or your clothing may be sufficient to destroy these devices if they are not handled properly. Use the following precautions to avoid damaging them:

CAUTION Many CMOS devices are installed in the Model 2182. Handle all semiconductor devices as being static sensitive.

- Transport and handle ICs only in containers specially designed to prevent static build-up. Typically, you will receive these parts in anti-static containers made of plastic or foam. Keep these devices in their original containers until ready for installation.
- Remove the devices from their protective containers only at a properly grounded work station. Also, ground yourself with a suitable wrist strap.
- Handle the devices only by the body; do not touch the pins.
- Ground any printed circuit board into which a semiconductor device is to be inserted to the bench or table.
- Use only anti-static type desoldering tools.
- Use only grounded-tip solder irons.
- Once the device is installed in the PC board, it is normally adequately protected, and you can handle the boards normally.

Assembly drawings

Use the following assembly drawings to assist you as you disassemble and reassemble the Model 2182. Also, refer to these drawings for information about the Keithley part numbers of most mechanical parts in the unit. The drawings are located at the end of this section.

- Front Panel Assembly — 2182-040
- Chassis/Transformer Power Supply Assembly — 2182-050
- Front Panel/Chassis Assembly — 2182-051
- Chassis Assembly — 2182-052
- Final Inspection — 2182-080

Disassembly

Case cover removal

Follow the steps below to remove the case cover to gain access to internal parts.

WARNING Before removing the case cover, disconnect the line cord and any test cables from the instrument.

1. Remove Handle — The handle serves as an adjustable tilt-bail. Adjust its position by gently pulling it away from the sides of the instrument case and swinging it up or down. To remove the handle, swing the handle below the bottom surface of the case and back until the orientation arrows on the handles line up with the orientation arrows on the mounting ears. With the arrows lined up, pull the ends of the handle away from the case.
2. Remove Mounting Ears — Remove the screw that secures each mounting ear. Pull down and out on each mounting ear.

NOTE When reinstalling the mounting ears, make sure to mount the right ear to the right side of the chassis, and the left ear to the left side of the chassis. Each ear is marked “RIGHT” or “LEFT” on its inside surface.

3. Remove Rear Bezel — To remove the rear bezel, loosen the two captive screws that secure the rear bezel to the chassis. Pull the bezel away from the case.
4. Removing Grounding Screws — Remove the two grounding screws that secure the case to the chassis. They are located on the bottom of the case at the back.
5. Remove Cover — To remove the case, grasp the front bezel of the instrument, and carefully slide the chassis forward. Slide the chassis out of the metal case.

Motherboard removal

Perform the following steps to remove the motherboard. This procedure assumes that the case cover is already removed.

1. Remove the IEEE-488, RS-232 and BNC jack fasteners.
The IEEE-488 and the RS-232 connectors each have two nuts that secure the connectors to the rear panel, while the BNC jack has a single nut. Remove these nuts.
2. Remove input jack.
Remove the four screws that secure the input jack PC board to the front panel. Remove the ground wire from the chassis bolt, then remove the assembly.
3. Remove cables.
 - Unplug the display board ribbon cable from connector J1003
 - Unplug the transformer cables from connectors J1015 and J1016.
 - Unplug the cable from J1014.
 - Remove the cables from the cable clips at each side of the chassis, and remove the cable ties.
4. Remove screw.
Remove the screw that secures the motherboard to the chassis. This screw also secures U304.
5. Remove the motherboard, which is held in place by edge guides on each side, by sliding it forward until the board edges clear the guides. Carefully pull the motherboard from the chassis.

Front panel disassembly

Use the following procedures to disassemble the front panel:

1. Remove power pushrod.
Carefully pry the end of the power pushrod free of the power switch.
2. Remove the front panel assembly.
This assembly has four retaining clips that snap onto the chassis over four pem nut studs. Two retaining clips are located on each side of the front panel. Pull the retaining clips outward and, at the same time, pull the front panel assembly forward until it separates from the chassis.
3. Using a thin-bladed screwdriver, pry the plastic PC board stop (located at the bottom of the display board) until the bar separates from the casing. Pull the display board from the front panel.
4. Remove the switch pad by pulling it from the front panel.

Main CPU firmware replacement

Changing the firmware may be necessary as upgrades become available. The firmware revision levels for the main and front panel CPUs are displayed during the power-on sequence. (The main firmware revision level is displayed on the left; the front panel firmware revision level is displayed on the right.) For example: REV: A01 A02 indicates a main firmware revision level of A01 and a front panel firmware revision level of A02.

The firmware for the main CPU is located in the EPROMs U102 (EVEN) and U103 (ODD), leadless ICs that reside in chip carriers on the PC board. To replace the CPU firmware, do the following:

WARNING **Disconnect the instrument from the power lines, and remove the test leads before changing the firmware.**

1. Remove the case cover as described earlier in this section.
2. Locate U102 EVEN and U103 ODD (EPROMs) on the motherboard. They are the only devices installed in chip carriers (sockets).

CAUTION **EPROMs U102 and U103 are static-sensitive devices. Be sure to follow the handling precautions explained in Static sensitive devices.**

3. Using an appropriate chip extractor, remove U102 from its chip carrier.
4. Position the new U102 EPROM on the appropriate chip carrier. Make sure the notched corner of the chip is aligned with the notch in the chip carrier.

NOTE *Be sure to install the correct EPROMs at the ODD and EVEN locations. The instrument will not function if the EPROMs are installed in the wrong sockets.*

5. With the EPROM properly positioned, push down on the chip until it completely seats into the chip carrier.
6. Repeat steps 3 through 5 for EPROM U103.
7. After installation, make sure the instrument powers up normally before replacing the cover.

Changing trigger link lines

The Model 2182 uses two lines of the TRIGGER LINK rear panel connector as External Trigger (EXT TRIG) input and Voltmeter Complete (VMC) output. At the factory, line 1 is configured as VMC and line 2 as EXT TRIG. Line 1, 3 or 5 of the Trigger Link can be configured as VMC, while line 2, 4 or 6 can be configured as EXT TRIG. You can change trigger link line configurations by changing the resistor connections summarized in [Table 5-1](#).

Table 5-1
Trigger link connections

Trigger link connection	Resistor
VMC to line 1*	R145
VMC to line 3	R146
VMC to line 5	R147
EXT TRIG to line 2*	R142
EXT TRIG to line 4	R143
EXT TRIG to line 5	R144

* Factory default

Perform the following steps to change trigger link lines:

WARNING Make sure the instrument is disconnected from the power line and other equipment before performing the following procedure.

1. Remove the cover from the instrument as explained in *Case cover removal*.
2. The resistors used to select the trigger link lines are located next to the Trigger Link connector. (See the motherboard component layout at the end of [Section 6](#).) The “resistors” are actually solder beads that bridge PC board pads. If the factory default lines are selected, the solder beads will be located at R145 (line 2, EXT TRIG) and R142 (line 1, VMC).
3. To change a trigger link line:
 - Use a soldering iron and solder sucker to remove the appropriate solder bead.
 - Using a solder with OA-based flux, apply a solder bead to the appropriate resistor location.
 - Replace the cover on the instrument.

CAUTION Use care when removing and installing resistors. Excessive heat may damage PC board pads or traces.

Removing power components

The following procedures to remove the power transformer and/or power module require that the case cover and motherboard be removed, as previously explained.

WARNING **Disconnect the line cord and input connector before removing the case cover.**

Power transformer removal

Perform the following steps to remove the power transformer:

1. Remove motherboard.
2. Unplug the transformer wires that are connected to the power module at the rear panel.
3. Remove the cable tie.
4. Remove the two nuts that secure the transformer to the bottom of the chassis.
5. Remove the transformer shield.
6. Pull the black ground wire off the threaded stud, and remove the power transformer from the chassis along with the shielded wires.

Power module removal

Perform the following steps to remove the power module:

1. Remove the motherboard.
2. Unplug the transformer wires that attach to the power module at the rear panel.
3. Disconnect the power module's ground wire. This green and yellow wire connects to a threaded stud on the chassis with a nut.
4. Squeeze the latches on either side of the power module while pushing the module from the access hole.

Instrument reassembly

Reassemble the instrument by reversing the previous disassembly procedures. Make sure that all parts are properly seated and secured, and that all connections are properly made.

WARNING To ensure continued protection against electrical shock, verify that power line ground (green and yellow wire attached to the power module) the power transformer ground (black wire), and input jack ground (green wire) are securely connected to the chassis. Also make sure that the case grounding screws at the bottom rear are securely installed.

Power module connections

During reassembly, connect power module wires as summarized in [Table 5-2](#).

Table 5-2
Power module connections

Wire	Color
Top	Gray
Right top	Violet
Right bottom	White
Left top	Red
Left bottom	Blue

Board installation

During reassembly, replace the motherboard, and start the IEEE-488, RS-232, and BNC jack connector nuts and the mounting screw. Tighten all the fasteners once they are all in place, and the board is correctly aligned.

2182-040

ON

LTR	ECA NO.	REVISION	ENG	DATE
B	29204	2182-326A Was 2182-314B; Update Used On Block	ST	2/24/04

STEP 1

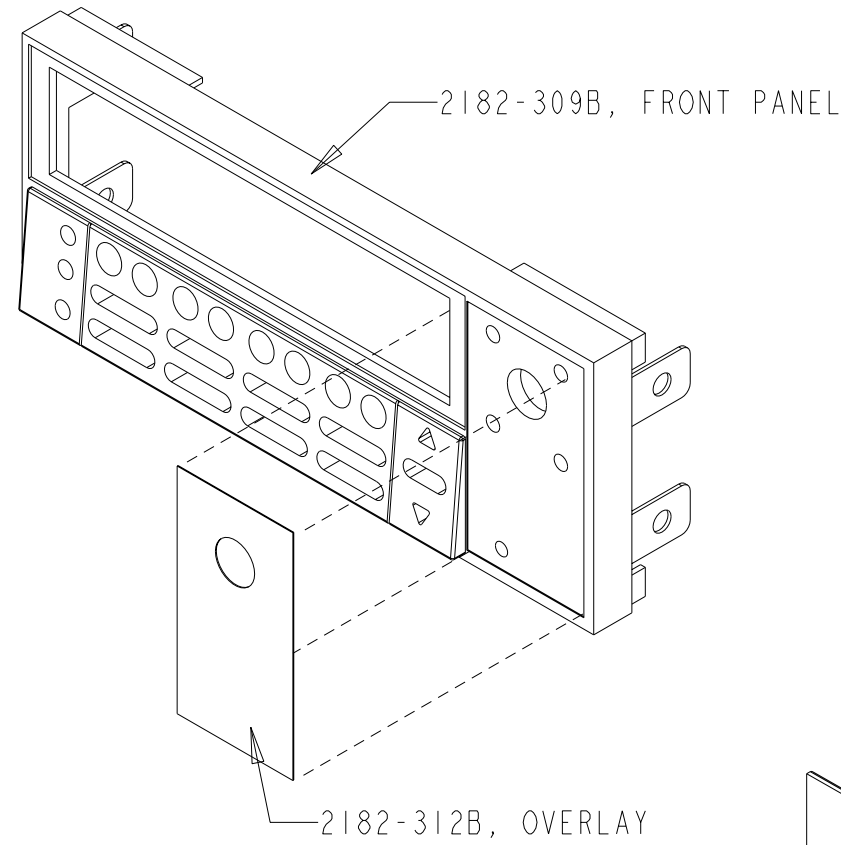

STEP 2

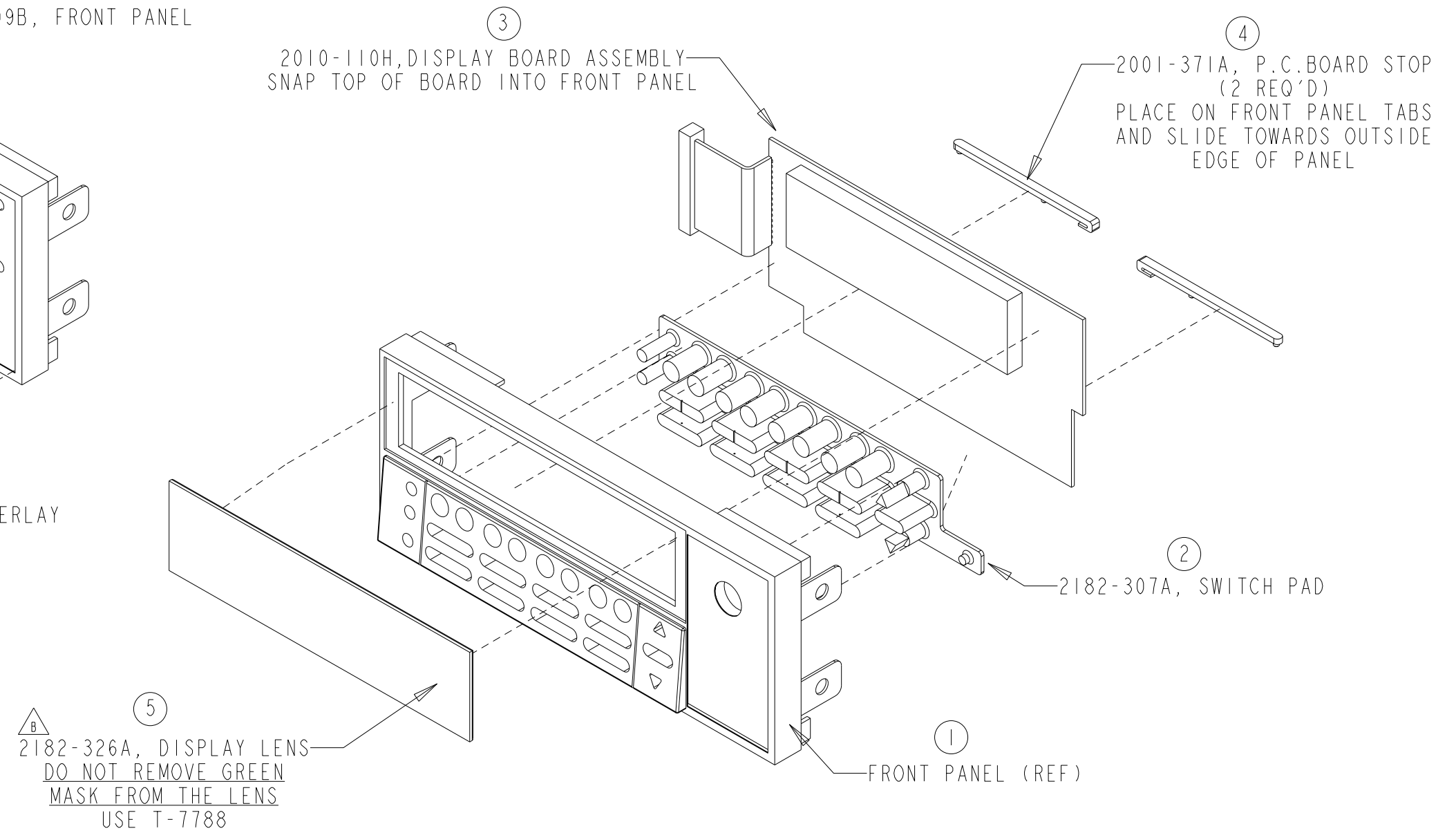

PART NUMBER	QTY	DESCRIPTION
2182-309B	1	FRONT PANEL
2010-110H	1	DISPLAY BOARD ASSEMBLY
2182-312B	1	OVERLAY
\triangle_B 2182-326A	1	DISPLAY LENS
2182-307A	1	SWITCH PAD
2001-371A	2	P.C. BOARD STOP

DO NOT SCALE THIS DRAWING

KEITHLEY Keithley Instruments Inc.
Cleveland, Ohio 44139

CONFIDENTIAL PROPRIETARY

DIMENSIONAL TOLERANCES UNLESS OTHERWISE SPECIFIED	
XX = \pm .015	ANG. = \pm °
XXX = \pm .005	FRAC. = \pm 1/64
SURFACE MAX. \sqrt{R}	

DATE	5/20/97	SCALE	-----	TITLE	Front Panel Assembly OP6
DRN.	MAT	ENG	APPR.	L.S.	
MATERIAL		FINISH			

\triangle_B 2182A	2182-051	Front Panel /Chassis Assembly	1
MODEL	NEXT ASSEMBLY	NEXT PROCESS STEP	QTY
USED ON			

\triangle_B NO. 2182-040

050-2812

ON

DETAIL A

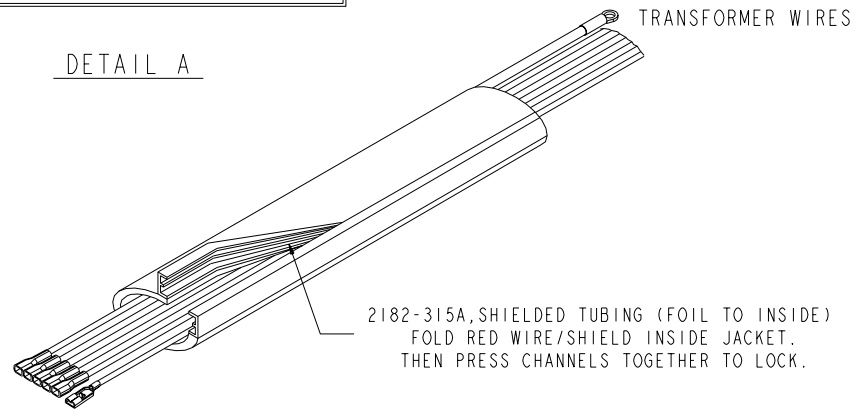

DETAIL B TRANSFORMER WIRING

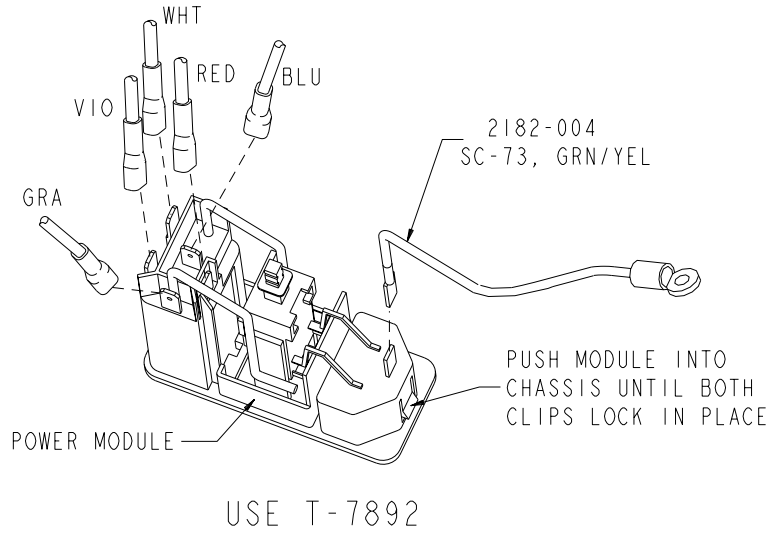

LTR	ECA NO.	REVISION	ENG	DATE
E	28535	2182-303E Was Rev D, Add MC-652A	ST	8/19/03

DETAIL C PROPERLY INSTALLED PUSH ROD
TOP VIEW

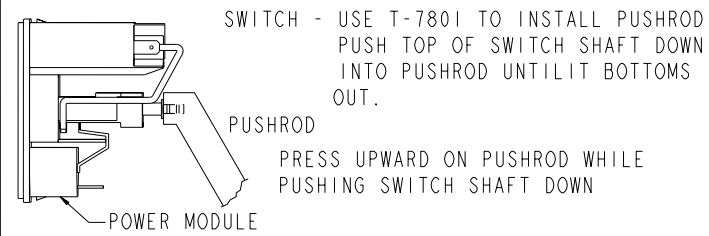

DETAIL D

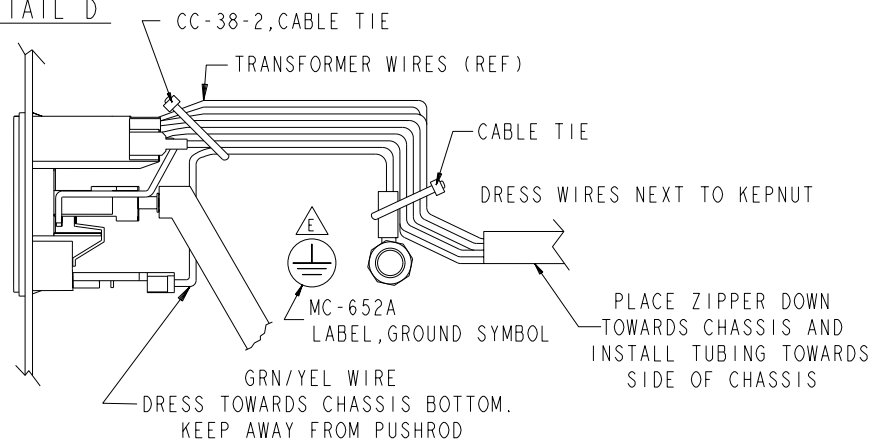

PART NUMBER	QTY	DESCRIPTION
2182-303E	1	CHASSIS
2001-320A	1	POWER PUSHROD
2182-315A	1	SHIELDED TUBING
2001-366-1A	1	RFI CLIP
428-319A	2	FOOT
FE-6	2	FOOT
FH-35-1	1	FUSE HOLDER
FU-96-4	1	FUSE 1/4 AMP
PM-1-1	1	POWER MODULE
2182-600A	1	TRANSFORMER
6-32x1/4PFH	2	PHIL FLAT HEAD SCREW
6-32KEPNUT	1	KEPNUT
MC-652A	1	LABEL, GROUND SYMBOL
8-32KEPNUT	2	KEPNUT
CC-37	2	CABLE CLAMP
CC-38-2	4	CABLE TIE
2182-320C	1	TRANSFORMER SHIELD
2010-307A	1	SUPPORT BRACKET

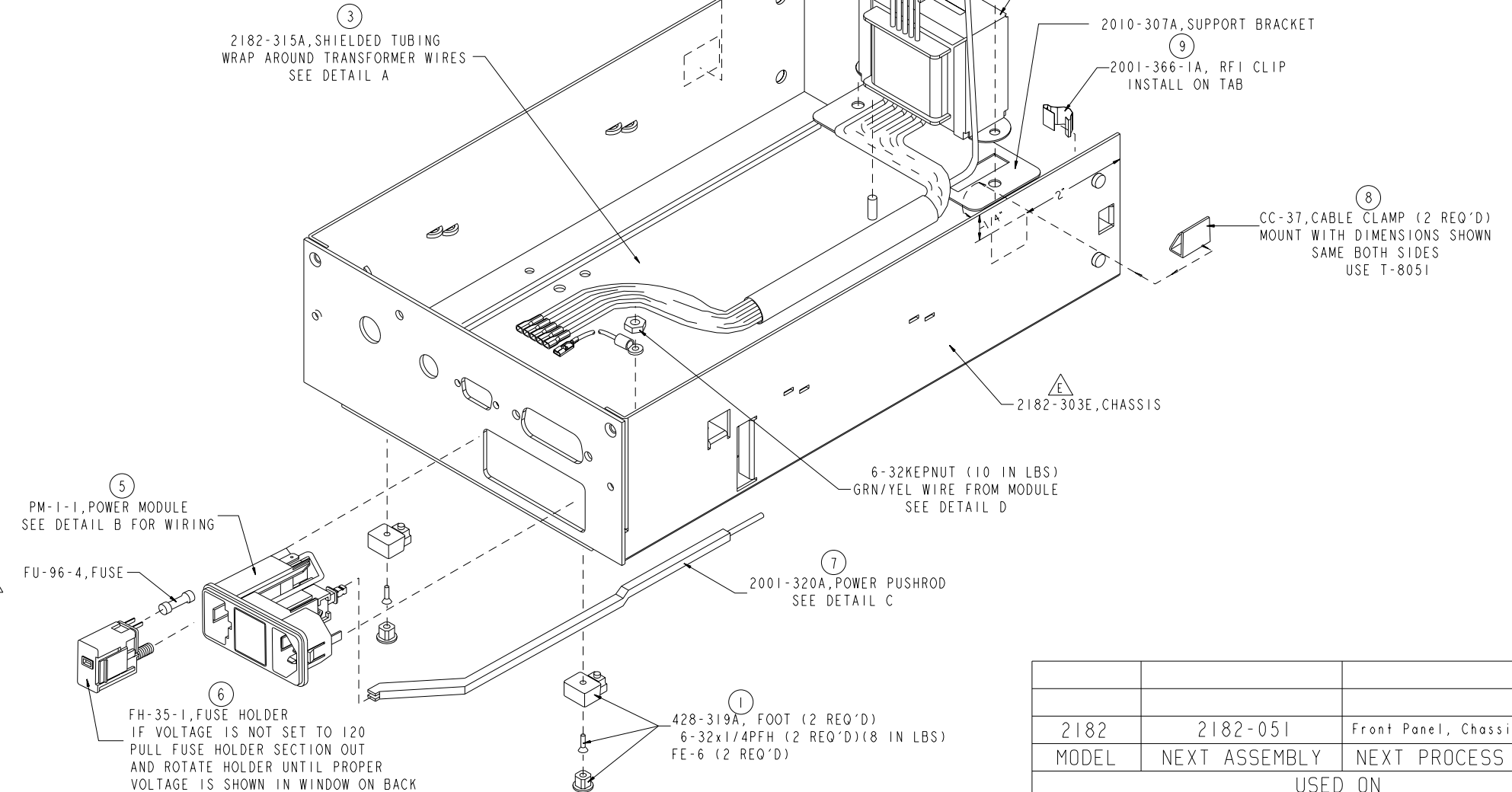

DO NOT SCALE THIS DRAWING		DIMENSIONAL TOLERANCES UNLESS OTHERWISE SPECIFIED		DATE 5/13/97	SCALE \times	TITLE CHASSIS/TRANSFORMER POWER SUPPLY ASSEMBLY	
XX = $\pm .015$ ANG = $\pm 1^\circ$		XXX = $\pm .005$ FRAC = $\pm 1/64$		DRN <i>Mat</i>	ENG APPR L.S.	NO. 2182-050	
SURFACE MAX \checkmark 63		FINISH				B	

KEITHLEY Keithley Instruments Inc.
Cleveland, Ohio 44139
CONFIDENTIAL PROPRIETARY

190-2812

ON

DI	29204	2182-250J Was 2182-250H; 2182A-803B03 Was 2182-803C01 2182A-804B03 Was 2182-804C01	ST	2/24/04	LTR	ECA NO.	REVISION	ENG	DATE
					D	28999	2182-250H Was 2182-250F5,2182-803B02 Was A12,2182-804B02 Was A12, Add MC-652A,CC-38-2 Qty 3	ST	10/30/03

4-40x5/16PPHSEM (5 IN LBS)

③
2182-250J, PANEL ASSEMBLY
(2182-102, DIGITAL BOARD ASSEMBLY)
(REF 2182A-803C01)
(REF 2182A-804C01)

RECOMMENDED PROCESS:

ALIGN BOARD SLOTS WITH LANCES ON CHASSIS.
BEING CAREFUL NOT TO PINCH P.C. WIRES OR
RIBBON CABLE.
SLIDE BOARD TOWARDS REAR PANEL.
AGAIN CHECKING WIRES.

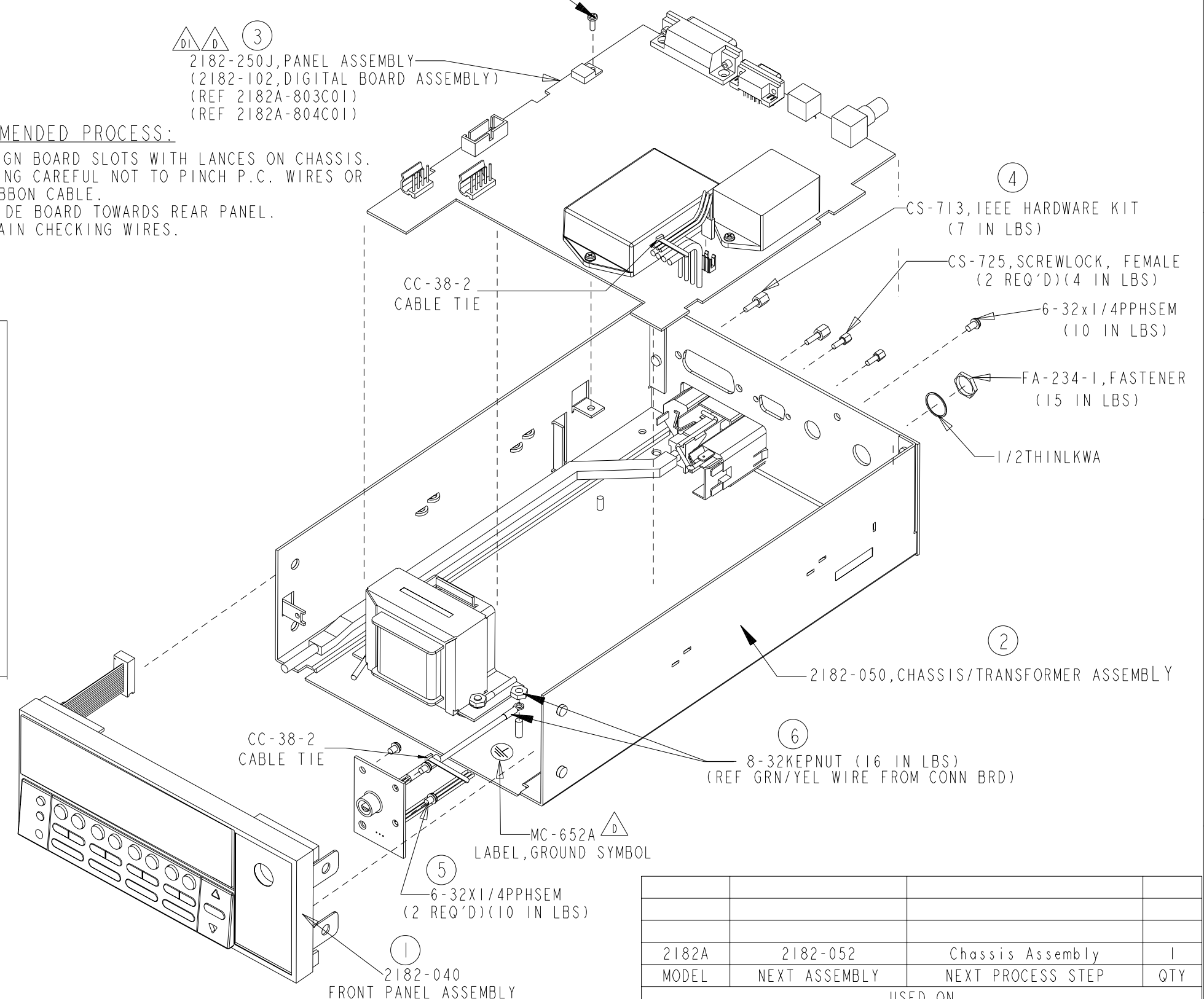
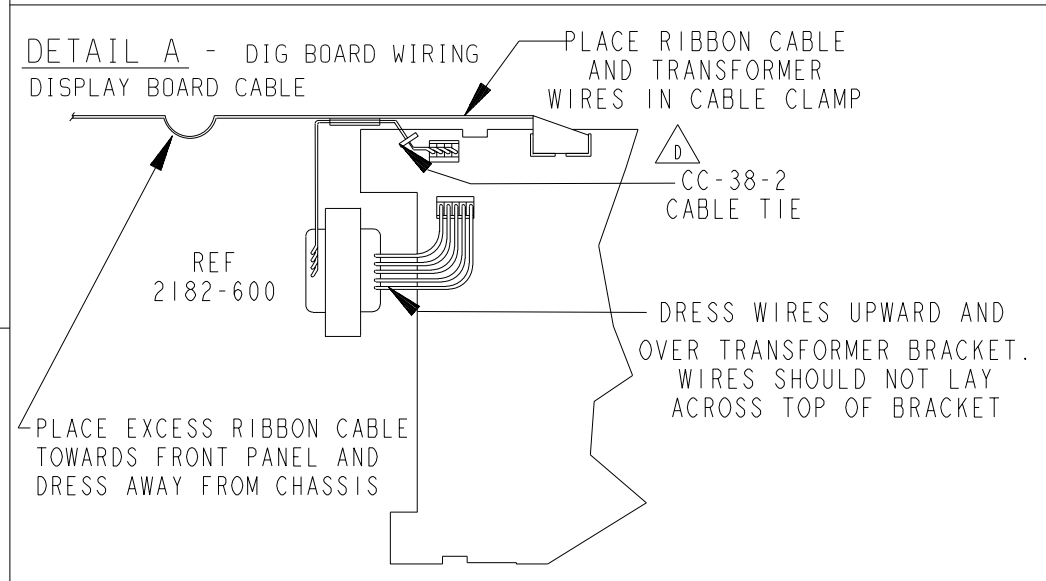

PART NUMBER	QTY	DESCRIPTION
2182-050	1	CHASSIS/TRANSFORMER ASSEMBLY
2182-040	1	FRONT PANEL ASSEMBLY
① 2182-250J	1	DIGITAL BOARD & CONNECTOR BOARD
		(REF 2182A-803C01)
		(REF 2182A-804C01)
CS-713	1	IEEE HARDWARE KIT
CS-725	2	SCREWLOCK, FEMALE
4-40X5/16PPHSEM	1	PHIL PAN HEAD SEMS SCREW
6-32X1/4PPHSEM	5	PHIL PAN HEAD SEMS SCREW
8-32KEPNUT	1	KEPNUT
FA-234-1	1	FASTENER
1/2THINLKWA	1	THIN LOCKWASHER
CC-38-2	3	CABLE TIE
MC-652A	1	LABEL, GROUND SYMBOL

2182A	2182-052	Chassis Assembly	1
MODEL	NEXT ASSEMBLY	NEXT PROCESS STEP	QTY
USED ON			

DO NOT SCALE THIS DRAWING

KEITHLEY Keithley Instruments Inc. Cleveland, Ohio 44139
CONFIDENTIAL PROPRIETARY

DIMENSIONAL TOLERANCES UNLESS OTHERWISE SPECIFIED		DATE	6/6/97	SCALE	----	TITLE	Front Panel/Chassis Assembly
XX = ±.015	ANG. = ±P	DRN.	Mat	ENG APPR.	LS		
XXX = ±.005	FRAC. = ±1/64	MATERIAL				B	NO. 2182-051
SURFACE MAX. √		FINISH					

290-2812

ON

LTR	ECA NO.	REVISION	ENG	DATE
B	28031	Add 428-329F Handle	ST	3/27/03

STEP 1

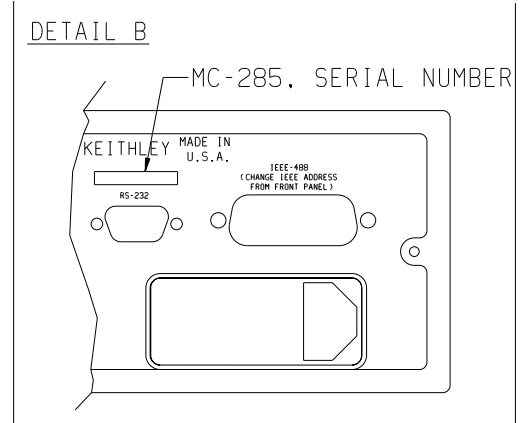
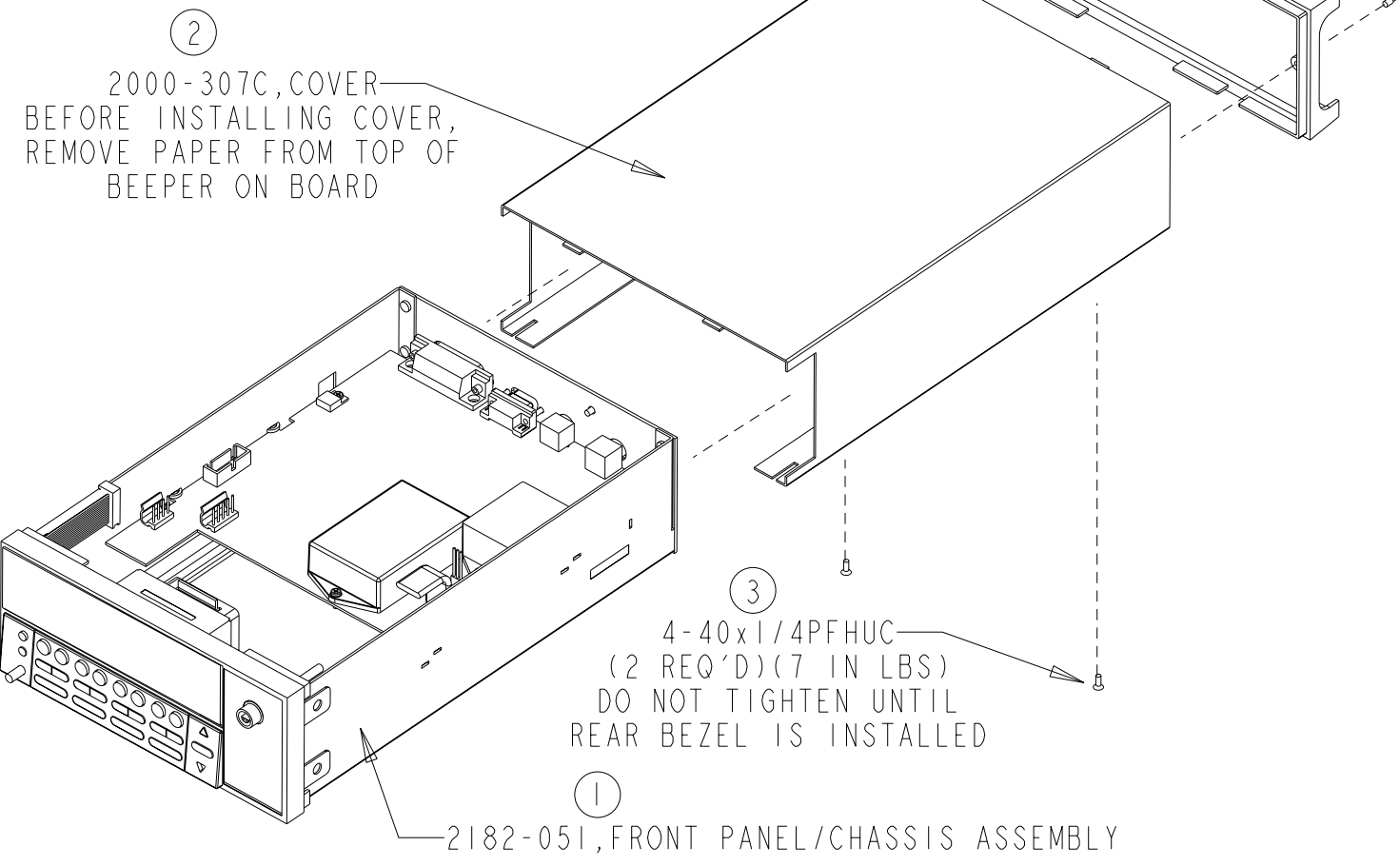

STEP 2

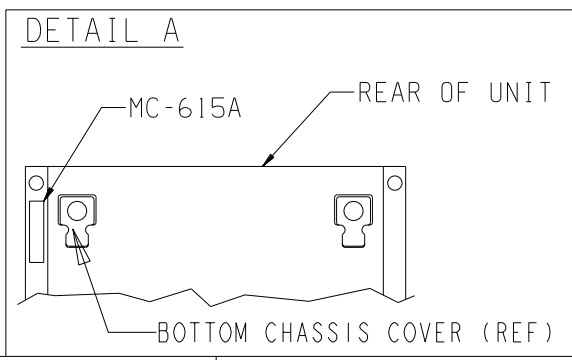
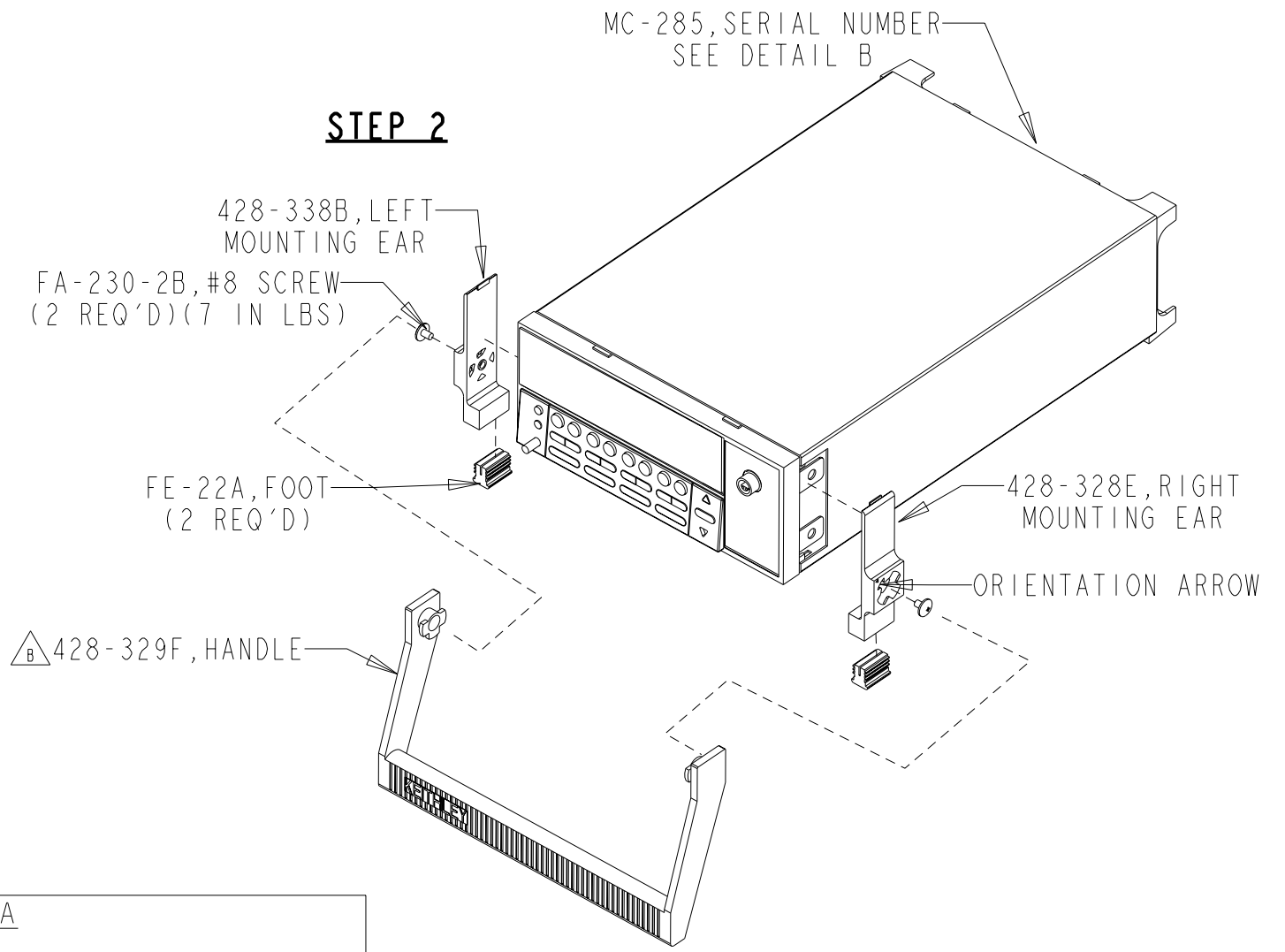

PART NUMBER	QTY	DESCRIPTION
2182-051	1	FRONT PANEL/CHASSIS ASSEMBLY
2000-307C	1	COVER
428-328E	1	RIGHT MOUNTING EAR
428-338B	1	LEFT MOUNTING EAR
FA-230-2B	2	FASTENER
FE-22A	2	FOOT
MC-615A	1	WARNING LABEL
4-40x1/4PFHUC	2	PHIL FLAT HEAD UNDERCUT SCREW
MC-285	1	SERIAL NUMBER
428-303D	1	REAR BEZEL
FA-232-1C	2	CAPATIVE PANEL SCREW
428-329F	1	HANDLE

2182			
MODEL	NEXT ASSEMBLY	NEXT PROCESS STEP	QTY
USED ON			

DO NOT SCALE THIS DRAWING

KEITHLEY Keithley Instruments Inc. Cleveland, Ohio 44139
CONFIDENTIAL PROPRIETARY

DIMENSIONAL TOLERANCES UNLESS OTHERWISE SPECIFIED
 XX = ±.015 ANG. = ±1'
 XXX = ±.005 FRAC. = ±1/64
 SURFACE MAX. √

DATE 6/4/97 SCALE - - - -
 DRN. *Mat* ENG APPR. LS

TITLE Chassis Assembly -- OP6

NO. B 2182-052

080-2812

ON

LTR	ECA NO.	REVISION	ENG	DATE
G	28031	Del PO-14-4,C0-26,C0-35 Various Updates	ST	3/27/03

- A) HIPOT TEST
 1) PERFORM HIPOT TEST TO IEC VOLTAGE SPEC PER MS-1537
- B) RECOMMENDED PROCESS:
 BEEPER INTENSITY TEST:
 1) TURN UNIT ON, LISTEN FOR BEEP.
 2) WAIT UNTIL FRONT PANEL DISPLAYS ALL NUMBERS.
 VERIFY FIRMWARE REV.
- VERIFY IEEE ADDRESS
 1) PRESS SHIFT, GPIB, DOWN ARROW.
 2) VERIFY ADDRESS READS 07.
 3) TO CHANGE ADDRESS TO 07, PRESS
 LEFT/RIGHT AND UP/DOWN ARROW KEYS.
 4) PRESS ENTER AND EXIT.

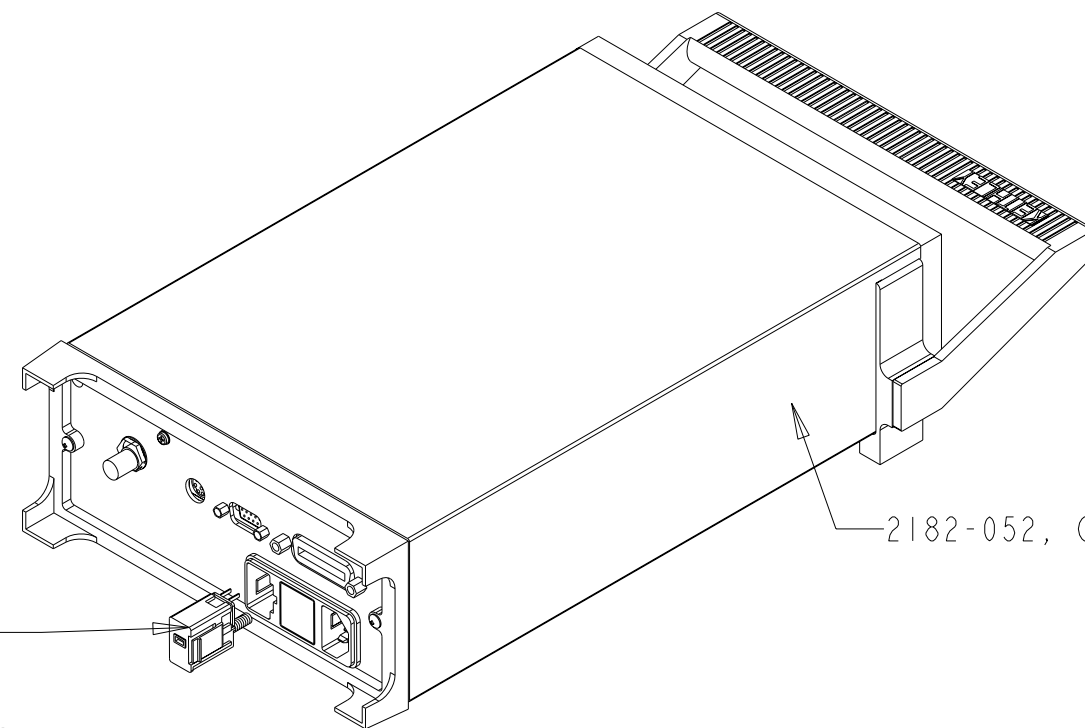

2182-052, CHASSIS ASSEMBLY

REMOVE FUSE HOLDER FROM UNIT
 PULL FUSE BLOCK SECTION OUT
 AND ROTATE UNTIL PROPER
 VOLTAGES WILL BE SHOWN IN WINDOW

VOLTAGE		FUSE
JAPAN	100V	FU-96-4 .25A
DOMESTIC	120V	EXISTING FUSE
EUROPE	220V	FU-91
-----	240V	

PLACE CERTIFICATE OF CALIBRATION AND SHIPPING LABEL
 ON TOP OF UNIT. SEND TO SHIPPING KIT

NOTE:
 UNIT IS TO BE SHIPPED WITH
 GREEN MASK ON THE LENS

PART NUMBER	QTY	DESCRIPTION
2182-052	1	CHASSIS ASSEMBLY
-----	1	CERTIFICATE OF CALIBRATION (PA-214 PRINTED IN PRODUCTION)
FOR EUROPE		
FU-91	1	FUSE 1/8 AMP

2182	SHIPPING KIT	1
MODEL	NEXT ASSEMBLY	NEXT PROCESS STEP QTY
USED ON		

DO NOT SCALE THIS DRAWING

KEITHLEY Keithley Instruments Inc.
 Cleveland, Ohio 44139
 CONFIDENTIAL PROPRIETARY

DIMENSIONAL TOLERANCES UNLESS OTHERWISE SPECIFIED
 XX = ±.015 ANG. = ±1°
 XXX = ±.005 FRAC. = ±1/64
 SURFACE MAX. √

DATE 08-Mar-00 SCALE --- TITLE FINAL INSPECTION
 DRN. *Mat* ENG APPR. LS
 MATERIAL FINISH

NO. 2182-080

6 Replaceable Parts

Introduction

This section contains replacement parts information and component layout drawings for the Model 2182.

Parts lists

The electrical parts lists for the Model 2182 are shown in tables at the end of this section. For part numbers to the various mechanical parts and assemblies, use the Miscellaneous parts list and the assembly drawings provided at the end of [Section 5](#).

Ordering information

To place an order, or to obtain information concerning replacement parts, contact your Keithley representative or the factory (see inside front cover for addresses). When ordering parts, be sure to include the following information:

- Instrument model number
- Instrument serial number
- Part description
- Component designation (if applicable)
- Keithley part number

Factory service

If the instrument is to be returned to Keithley Instruments for repair, perform the following:

- Call the Repair Department at 1-800-552-1115 for a Return Material Authorization (RMA) number.
- Complete the service form at the back of this manual, and include it with the instrument.
- Carefully pack the instrument in the original packing carton.
- Write ATTENTION REPAIR DEPARTMENT and the RMA number on the shipping label.

Component layouts

The component layouts for the various circuit boards are provided on the following pages. Drawings include:

- Motherboard - 2182-250
- Display board - 2010-110

Table 6-1
Motherboard parts list

Circuit designation	Description	Keithley part no.
C101-113,130-132,136-141,150,152,501-505	CAP, .1UF, 10%, 25V, CERAMIC	C-495-.1
C114,C116,C117,C323	CAP, .1UF, 10%, 25V, CERAMIC	C-495-.1
C118,134,515,520,751,758,761,763,765	CAP, 47P, 5%, 100V, CERAMIC	C-465-47P
C119,C120	CAP, 22P 5%, 100V CERAMIC	C-465-22P
C129,C135,C127,C128	CAP, 47P, 5%, 100V, CERAMIC	C-465-47P
C133	CAP, .01UF, 10%, 50V CERAMIC	C-491-.01
C153	CAP,1UF,20%,50V, CERAMIC	C-237-1
C154,155,511-514,651,653,656,661,662,664	CAP,.1UF, 20%,50V,CERAMIC	C-418-.1
C302	CAP,4700UF,-20+100%,16V,ALUMINUM	C-313-4700
C303,C317,C318	CAP, 1000UF, -20+100%, 16V ALUMINUM	C-313-1000
C305,C306,C307,C308	CAP, 470UF, 20%, 63V ALUM ELEC	C-477-470
C311,C312	CAP, 1000UF, 20%, 50V ALUM ELEC	C-469-1000
C314,C316	CAP,47UF,+/-20%, 25V, ALUM ELEC	C-314-47
C320	CAP, 6800UF, -20+100%, 16V ALUMINUM	C-313-6800
C322	CAP, 10UF,20%, 25V, TANTALUM	C-440-10
C324	CAP, .1UF, 20%,100V, CERAMIC	C-436-.1
C325	CAP,100UF,20%,63V,ALUM ELEC	C-403-100
C326	CAP,.1UF, 20%,50V,CERAMIC	C-418-.1
C327,C330,C331,C631	CAP,100PF, 5%, 100V, CERAMIC	C-465-100P
C506,C509	CAP, 2200P, 10%, 100V CERAMIC	C-430-2200P
C507,C508	CAP,100PF, 5%, 100V, CERAMIC	C-465-100P
C510	CAP, 22UF, 20%, 25V, TANTALUM	C-440-22
C517,602, 611,624,142,143	CAP, 1000pF, 20%, 50V, CERAMIC	C-418-1000P
C518	CAP, 1000pF, 20%, 50V, CERAMIC	C-418-1000P
C519,753-757,759,319,121,122	CAP, .1UF, 10%, 25V, CERAMIC	C-495-.1
C606,C665,C615,C626	CAP, 220PF, 10%, 100V, CERAMIC	C-451-220P
C613,601,603,622,630,144	CAP,.1UF, 20%,50V,CERAMIC	C-418-.1
C617	CAP, 1000P, 10%, 100V, CERAMIC	C-451-1000P
C618,619,156,301,304,309,310,313,315,321	CAP,.1UF, 20%,50V,CERAMIC	C-418-.1
C620	CAP, 220PF, 10%, 100V, CERAMIC	C-451-220P
C625	CAP, 2.2UF, 20%, 63V, POLYCARB	C-480-2.2
C627,C660	CAP,100PF,2.5%,630V,POLYPROPYLENE	C-405-100P
C629,C635	CAP, 22PF, 10%, 100V, CERAMIC	C-451-22P
C650,C658	CAP, 47PF, 10%, 100V, CERAMIC	C-451-47P
C655,C752,C760,C614,160,162	CAP, .01UF, 10%, 50V CERAMIC	C-491-.01
C659,C621,C654	CAP, 47PF, 10%, 100V, CERAMIC	C-451-47P
C663,C668,C669	CAP,.01UF,10%,1000V,CERAMIC	C-64-.01
C666,762,764,766,623,328,329,610,628,616	CAP,.1UF, 20%,50V,CERAMIC	C-418-.1
C667,C612	CAP, 1000P, 10%, 100V, CERAMIC	C-451-1000P

Table 6-1*Motherboard parts list (continued)*

Circuit designation	Description	Keithley part no.
CN701	MODIFIED POTTING BOX	2182-321A
CN702	SHIELD	CN-68
CN703	SHIELD	CN-70
CR101,102,316,317,654	DIODE, DUAL SWITCHING, BAV99L	RF-82
CR301-309,311-314	DIODE, SWITCHING, MMSD914T19	RF-112
CR310	DIODE,BRIDGE,VM18	RF-52
CR315	DIODE,SILICON,W04M (CASE WM)	RF-46
CR501,CR653,CR606,CR607,CR651,CR652	DIODE, DUAL HSM-2822T31	RF-95
CR502,CR602,CR603	DIODE, SWITCHING, MMBD914	RF-83
CR601,CR604	DIODE, DUAL COMMON ANODE BAW56LT2	RF-98
J1005	CONN, HEADER STRAIGHT SOLDER PIN	CS-368-16
J1006	CONN, MICRODIN W/GND FINGERS	CS-792
J1007	CONN, RT ANGLE, MALE, 9 PIN	CS-761-9
J1008	CONN,RIGHT ANGLE,24 PIN	CS-501
J1014	LATCHING HEADER,FRICTON, SGL ROW	CS-724-3
J1015	CONNECTOR, HEADER	CS-784-4
J1016	CONN, MALE, 5-PIN (MOLEX 42491)	CS-784-5
J1017	CONN, BNC	CS-547
L101,L502,L503,L504	FERRITE CHIP 600 OHM BLM32A07	CH-62
L102,L103,L501,L505	FERRITE CHIP 600 OHM BLM32A07	CH-62
L301,L302	CHOKE	CH-61
L650,L653,L654	CHOKE, EMI	CH-57
L651,L652	CHOKE, 100UH	CH-14
L655,L601,L602	CHOKE, 22UH	CH-66-22
LS101	BEEPER, 5V, 30MA, BRT1209P-06-C	EM-5
Q101,301,303,605,752,631,632	TRANS, NPN, MMBT3904	TG-238
Q302,304,606,751,626,636	TRANS, PNP, MMBT3906L	TG-244
Q501-504,675,676,640	TRANS, N-MOSFET, VN0605T	TG-243
Q505,625,628,629,650,659,660,665,672-674	TRANS, N CHANNEL JFET, SNJ132199	TG-294
Q506,Q635	TRANS, N-CHAN JFET, SST4393	TG-263
Q601,Q602	TRANS PNP, BC 856BL	TG-287
Q603,Q607	TRANS,NPN COMP SILICON AMP,MPS8099	TG-157
Q604,Q610	TRANS,PNP COMP SILICON AMP,MPS8599	TG-158
Q608,Q609	TRANS, NPN SILICON, BC846BL,	TG-278
Q611,Q612,Q613,Q614	TRANS,N CHAN MOSPOW FET,2N7000	TG-195
Q615-618,637,655-657	TRANS, PNP, BC860C	TG-323

Table 6-1
Motherboard parts list (continued)

Circuit designation	Description	Keithley part no.
Q619,Q652	TRANS, NPN PAIR, LM394	TG-142
Q620,Q621	TRANS, N CHANNEL JFET, SST4118	TG-347
Q624,U651	SELECTED TRANSISTOR	2010-600A
Q627,Q630	TRANS,N CHANNEL JFET	TG-225
Q633,Q634,Q638,Q670,Q639,Q507	TRANS, N CHANNEL JFET, SNJ132199	TG-294
Q658,Q663,Q664,Q622,Q623,Q671	TRANS,N CHANNEL FET,2N4392	TG-128-1
Q661,Q662	TRANS, N-CHAN MOSFET, TN254ON8	TG-274
Q666,Q667	TRANS,P-FET, MTP2N90	TG-232
R101,R507,R525,R526,124,149,153,162, 168	RES, 10K, 1%, 100MW, THICK FILM	R-418-10K
R102-107,110-112,117-120,123,515, 165,171	RES, 4.75K, 1%, 100MW, THICK FILM	R-418-4.75K
R113,R136,R318,R169	RES, 1K, 1%, 100MW, THICK FILM	R-418-1K
R114,137,518,520,522,759-761,163,521	RES, 1K, 1%, 100MW, THICK FILM	R-418-1K
R115,R116,R502,R503	RES, 2.21K, 1%, 100MW, THICK FILM	R-418-2.21K
R121,127-129,504,516,611,612,628,629	RES, 100, 1%, 100MW, THICK FILM	R-418-100
R122	RES, 10, 10%, 100MW, THICK FILM	R-418-10
R125,138,148,306,307,509	RES, 10K, 1%, 100MW, THICK FILM	R-418-10K
R131,R130	RES, 100, 1%, 100MW, THICK FILM	R-418-100
R132,R308	RES, 357, 1%, 100MW, THICK FILM	R-418-357
R133-135,151,152,154,512	RES, 475, 1%, 100MW, THICK FILM	R-418-475
R139	RES, 49.9, 1%, 100MW THICK FILM	R-418-49.9
R140,R633	RES, 2.21K, 1%, 100MW, THICK FILM	R-418-2.21K
R141	RES, 200, 1%, 100MW, THICK FILM	R-418-200
R142,R145	RES, .0499, 1%, 100MW, THICK FILM	R-418-.0499
R150	RES, 475, 1%, 100MW, THICK FILM	R-418-475
R155	RES, 332, 10%, 125MW METAL FILM	R-391-332
R157	RES,243K, 1%, 125MW, METAL FILM	R-391-243K
R158	RES, 90.9K, 1%, 125mW, METAL FILM	R-391-90.9K
R159	RES,1K, 5% 250MW, METAL FILM	R-376-1K
R160	RES, 10K, 1%, 100MW, THICK FILM	R-418-10K
R161,R674,R686	RES, 1K, 1%, 100MW, THICK FILM	R-418-1K
R164,R170	RES, 100K, 1%, 100MW THICK FILM	R-418-100K
R301,R302,R303	RES,10,5%,125MW,METAL FILM	R-375-10
R304,R311	RES, 15k, 1%, 100MW, THICK FILM	R-418-15K
R305	RES, 33.2K, 1%, 100MW, THICK FILM	R-418-33.2K
R309,R314	RES, 10K, 1%, 125mW, METAL FILM	R-391-10K
R310,R316	RES, 100, 1%, 125mW, METAL FILM	R-391-100
R312,R315	RES, 20K, 1%, 100MW THICK FILM	R-418-20K
R317,R631	RES, 15K, 1%, 125mW, METAL FILM	R-391-15K
R319,R320,R321	RES, 3.01K, 1%, 100MW THICK FILM	R-418-3.01K
R322	RES, 100K, 1%, 125mW, METAL FILM	R-391-100K
R323	RES, 150, 5%, 250MW, METAL FILM	R-376-150

Table 6-1
Motherboard parts list (continued)

Circuit designation	Description	Keithley part no.
R501	RES, 1.28M, .1%, 1/8W METAL FILM	R-176-1.28M
R505	RES, 5.11K, 1%, 100MW, THICK FILM	R-418-5.11K
R506,R691	RES, 470,5%, 125MW, METAL FILM	R-375-470
R508,R625	RES, 24.9K, 1%, 100MW, THICK FILM	R-418-24.9K
R510	RES, 49.9K, 1%, 100MW THICK FILM	R-418-49.9K
R511	RES,4.02K,1%,100MW, THICK FILM	R-418-4.02K
R513	RES, 34K, 1%, 100MW, THICK FILM	R-418-34K
R514	RES, 82.5, 1%, 100MW, THICK FILM	R-418-82.5
R517,R523	RES, 1M, 1%, 100MW, THICK FILM	R-418-1M
R519	RES, 10, 10%, 100MW, THICK FILM	R-418-10
R524,667,668,602,635,639,676,680,683,698	RES, 49.9K, 1%, 100MW THICK FILM	R-418-49.9K
R600	RES, 450, .1%, 1/8W METAL FILM	R-377-450
R601	RES, 511, 1%, 100MW, THICK FILM	R-418-511
R603,R604	RES, 3.01K, 1%, 125MW, METAL FILM	R-391-3.01K
R605	RES, 511, 1%, 100MW, THICK FILM	R-418-511
R608,R609,R685	RES, 1K, 1%, 125mW, METAL FILM	R-391-1K
R610,R684,R626,R699,R703	RES, 1K, 1%, 125mW, METAL FILM	R-391-1K
R613	RES, 6.98K, 1%, 125MW, METAL FILM	R-391-6.98K
R614	RES, 4.99K, 1%, 100MW THICK FILM	R-418-4.99K
R615,R618	RES, 604, 1%, 100MW THICK FILM	R-418-604
R616,R617	RES, 392, 1%, 100MW, THICK FILM	R-418-392
R622	RES, 1.07K, .1%, .125W THIN FILM	R-456-1.07K
R623,R657	RES, 20, 1%, 100MW, THICK FILM	R-418-20
R624,R627	RES, 200, 1%, 100MW, THICK FILM	R-418-200
R630,R655,R658,R660	RES, 1K, 1%,125MW THIN FILM	R-423-1K
R632,R619	RES, 1K, 1%,125MW THIN FILM	R-423-1K
R637	PRECISION DIVIDER	TF-256
R641,R717	RESISTOR, PRECISION	R-410-100
R642,R659	RES,49.9K,1%,125MW, METAL FILM	R-391-49.9K
R644	RES, 26.7K, 1%, 125mW,METAL FILM	R-391-26.7K
R645,646,678,634,638,643,649,675,682,697	RES,49.9K,1%,125MW, METAL FILM	R-391-49.9K
R648	RES, 4.5K, .1%, 1/8W METAL FILM	R-377-4.5K
R650,652,661,662,640,647,669,708,711	RES, 1K, 1%, 125mW, METAL FILM	R-391-1K
R651	RES, 6.65K, 1%, 125MW, METAL FILM	R-391-6.65K
R653	RES, 137, 1%, 125MW, METAL FILM	R-391-121
R654	RES, 15K, 1%, 125mW, METAL FILM	R-391-15K
R656	RES, 499, 1%, 125MW, METAL FILM	R-391-499
R663	RES, 26.7K, 1%, 125mW,METAL FILM	R-391-26.7K
R664	RES, 9.09K, .1%, 1/10W, METAL FILM	R-263-9.09K
R665	RES, .1%, 1/8W METAL FILM	R-377-1K
R666	RES, 100, .1%, 1/10W, METAL FILM	

Table 6-1
Motherboard parts list (continued)

Circuit designation	Description	Keithley part no.
R670,R673,R687,R688	RES, 2.49K, 1%, 125MW, METAL FILM	R-391-2.49K
R671,672,689,690,694,695	RES, 1M, 5%, 125MW, METAL FILM	R-375-1M
R681	RES, 20K,1%,125MW, METAL FILM	R-391-20K
R692	RES, 4.99K, 1%, 125mW,METAL FILM	R-391-4.99K
R693	RES, 5K, .1%, WIREWOUND	R-249-5K
R700	THICK FILM SMT	TF-263-100K
R701	RES, 15k, 1%, 100MW, THICK FILM	R-418-15K
R706,707,108,109,677,679,710,713,715	RES, 49.9K, 1%, 100MW THICK FILM	R-418-49.9K
R709,R712,R714,620,621	RES,49.9K,1%,125MW, METAL FILM	R-391-49.9K
R716	RES, 17.2K, .1%, .125W, THIN FILM	R-456-17.2K
R718	RES, 1M, 1%, .125MW THICK FILM	R-423-1M
R751	RES NET	TF-245
R752	RES, 6.04K, 1%, 125MW, THIN FILM	R-423-6.04K
R753,R758	RES, 2K, 1%, 100MW, THICK FILM	R-418-2K
R754	RES, 49.9K, 1%, 125MW, METAL FILM	R-391-2.87K
R755,R313	RES, 2.49K, 1%, 125MW, METAL FILM	R-391-2.49K
R756	RES, 3.01K, 1%, 125MW, METAL FILM	R-391-3.01K
R757,762,763,636,702	RES, 100K, 1%, 100MW THICK FILM	R-418-100K
RV653,RV660	VARISTOR	VR-8
RV658	VARISTOR	VR-16
RV659	VARISTOR	VR-9
SA650,SA653	SURGE ARRESTOR	SA-7
SA651	SURGE ARRESTOR	SA-1
SA652	SURGE ARRESTOR CG2-300L	SA-2
TP301,TP303,TP651,TP652,TP601	CONN,TEST POINT	CS-553
U101	IC, 16BIT MICROPROCESSOR MC68306FC16A	LSI-154
U102	PROGRAMMED ROM	2182-804**
U103	PROGRAMMED ROM	2182-803**
U104,U105	IC,32KX8 STAT CMOS RAM,D43256C	LSI-93-100
U106	IC, GPIB ADAPTER, 9914A	LSI-123
U108	IC,OCTAL INTERFACE BUS,75160	IC-646
U109	IC,OCTAL INTER BUS TRANS,75161	IC-647
U110	IC +5V RS-232 TRANSCEIVER, MAX202	IC-952
U112	IC, SERIAL EPROM 24LC16B	LSI-153
U113,U117	IC,POS NAND GATES/INVERT,74HCT14	IC-656
U114	IC,DUAL HIGH CMR/SPEED OPTO,HCPL-2631	IC-588
U115,U116	IC,OPTOCOUPLER,2601	IC-239
U121	IC, QUAD 2 INPUT OR, 74HCT32	IC-808
U150	INTEGRATED CIRCUIT SMT	IC-1136

*Order present firmware revision level.

Table 6-1
Motherboard parts list (continued)

Circuit designation	Description	Keithley part no.
U151,U613,U629,U307,U308	IC,OP-AMP,AD707,	IC-712
U301	IC,+5V REGULATOR,500mA,7805	IC-93
U302	IC,POS VOLTAGE REG +15V,500MA,78M15	IC-194
U303	IC,NEG VOLTAGE REG -15V,500MA,79M15	IC-195
U304	IC, LOW DROPOUT REGULATOR, LM295T	IC-962
U305	IC, VOLTAGE REG LM317M	IC-846
U306,U310	IC, PROGRAMMABLE, PRECISION-REF TL431CD	IC-1042
U309,U507	IC, OP-AMP, NE5534D	IC-802
U503	IC, QUAD D FLIP FLOP W/CLK,RESET 74HC175	IC-923
U504	IC, NCHAN LAT DMOS QUADFET, SD5400CY	IC-893
U505	PRECISION BIFET OPAMP	IC-1194
U506	INTEGRATED CIRCUIT, OPA177GS	IC-960
U508	IC, VOLT. COMPARATOR,LM311M	IC-776
U510	PROGRAMMED ROM	2000-802**
U511,U648,U122	IC, VOLT COMPARATOR LM393D	IC-775
U601,U600	IC, OP-AMP, LTC1050CS8	IC-791
U602	INTEGRATED CIRCUIT SMT	IC-1140
U603,U123	IC, RETRIG., MULTIVIB, 74HC123AM	IC-788
U604,U509,U107,U111,U119,U120	IC, DUAL D-TYPE F/F, 74HC74	IC-773
U605,U501,U502	IC, QUAD 2 IN NOR, 74HCT02	IC-809
U606,U609,U635,U640	IC, MOSFET DRIVER, TLP591B	IC-877
U607,U610	INTEGRATED CIRCUIT SMT	IC-1182
U611,U632,U641	IC, CMOS ANAL SWITCH, DG444DY,	IC-866
U612,U628	IC,AJD SHUNT REGULATOR,TL431CLP	IC-677
U614,U630,U634	IC, OP-AMP, MC34081BD	IC-1058
U616,U617,U631,U633	IC, PHOTO TRANS, TLP626BV-LFI	IC-1006
U620,U118	IC, QUAD 2 IN AND, 74HCT08	IC-837
U625,U755,U756,U757	IC, 8 STAGE SHIFT/STORE,MC14094BD	IC-772
U626	IC, 8-CHAN ANA MULTIPLEXER,DG408DY	IC-844
U636,U639	IC, PHOTO, DARLINGTON TRANS, PS2506L-1	IC-911
U637,U615	IC, QUAD COMPARATOR,LM339D	IC-774
U638,U618,U627	ICM DUAL J-FET OP-AMP, OP-282GS,	IC-968
U643	IC,CMOS ANALOG SWITCH DG211DY	IC-768
U645,U619	IC, CMOS ANAL. SWITCH, DG411DY	IC-785
U753	IC, PRECISION REFERENCE, LM399	196-600A
U754	IC, DUAL BIPOLAR OP-AMP, LT1124CS8	IC-955

**Order present firmware revision level.

Table 6-1*Motherboard parts list (continued)*

Circuit designation	Description	Keithley part no.
VR151,152,303,602,608,650,603	DIODE,ZENER 5.1V, BZX84C5V1	DZ-88
VR301,VR302,VR655,VR656	DIODE, ZENER 11V,MMSZ11T1	DZ-103
VR304	DIODE ZENER	DZ-121
VR601,VR604,VR613,VR614	DIODE, ZENER 3.3V, MMBZ5226BL	DZ-94
VR609,VR610,VR651,VR652	DIODE ZENER 12V, MMSZ12T1	DZ-112
VR611,VR612	DIODE ZENER 12V, MMSZ12T1	DZ-112
VR654,VR657	DIODE, ZENER 6.0V, BZX84B6V2	DZ-87
VR751,VR753,VR605,VR606	DIODE, ZENER, 6.2V MMSZ6V2	DZ-97
VR752	DIODE,ZENER 6.4V, IN4579	DZ-73
Y101	CRYSTAL	CR-55-1
Y501	OSCILLATOR HIGH SPEED CMOS 12MHZ	CR-37

Table 6-2*Display board parts list*

Circuit designation	Description	Keithley part no.
C401,C402,C411	CAP,.1UF, 20%,50V,CERAMIC	C-418-.1
C414	CAP, 47PF, 10%, 100V, CERAMIC	C-451-47P
C403-405,407,409,410,412	CAP, .1UF, 10%, 25V, CERAMIC	C-495-.1
R405,R408,R410,R412	RES, 12.1, 1%, 125MW METAL FILM	R-391-12.1
R420,R421	RES, 10K, 1%, 100MW, THICK FILM	R-418-10K
R413	RES, 13K, 1%, 100MW, THICK FILM	R-418-13K
R401-404,406,409,411,414-418	RES, 15k, 1%, 100MW, THICK FILM	R-418-15K
CR401,CR402	DIODE, MBR0520LT1	RF-103
P1005	CABLE ASSEMBLY	CA-123-16A
DS401	DISPLAY	DD-52
U401	PROGRAMMED ROM	2000-800**
C413	CAP,22UF, 20%, 6.3,TANTALUM	C-417-22
C406,C408	CAP, 33PF, 10%, 100V, CERAMIC	C-451-33P
Y401	CRYSTAL, 4MHZ (SMT)	CR-36-4M
U402,U403	IC, LATCHED DRIVERS,UCN-5812EPF-1	IC-732
R419	RES, 10M, 5%, 125MW, METAL FILM	R-375-10M
U103	PROGRAMMED ROM	2182-803**
U102	PROGRAMMED ROM	2182-804**

**Order present firmware revision level.

Table 6-3*Connector board parts list*

Circuit designation	Description	Keithley part no.
C670 U644	CONNECTOR	CS-236
	CONNECTOR, HOUSING	CS-638-3
	CONNECTOR	CS-933
	CAP,.1UF, 20%,50V,CERAMIC	C-418-.1
	IC, CENTIGRADE TEMP SENSOR LM35DM	IC-906

Table 6-4*Mechanical parts list*

Qty.	Description	Keithley part no.
1	BEZEL, REAR	428-303D
1	CHASSIS	2182-304
1	COVER	2000-307C
2	FOOT	428-319A
2	FOOT, EXTRUDED	FE-22A
2	FOOT,RUBBER	FE-6
1	FRONT PANEL	2182-306A
1	FUSE 0.25A	FU-96-4
1	FUSE HOLDER	FH-35-1
1	HANDLE	428-329F
1	LINE CORD	CO-7
1	LINE MODULE	PM-1-1B
1	MOUNTING EAR, LEFT	428-338B
1	MOUNTING EAR, RIGHT	428-328E
1	POWER ROD	2001-320A
1	REAR PANEL	2182-302
1	RFI CLIP, CHASSIS	2001-366-1A
1	SWITCHPAD	2182-307A
1	TRANSFORMER	TR-299B
1	TRANSFORMER SHIELD	2182-320B

LTR.	ECA NO.	REVISION	ENG.	DATE
H	27421	ARTWORK WAS REV G. ADDED C415-C418, R422-R426 CHG'D C414 FROM C-451-47P TO C-451-1000P.	AJS	06/26/02

PRIMARY (TOP) SIDE COMPONENTS (SIDE -02)

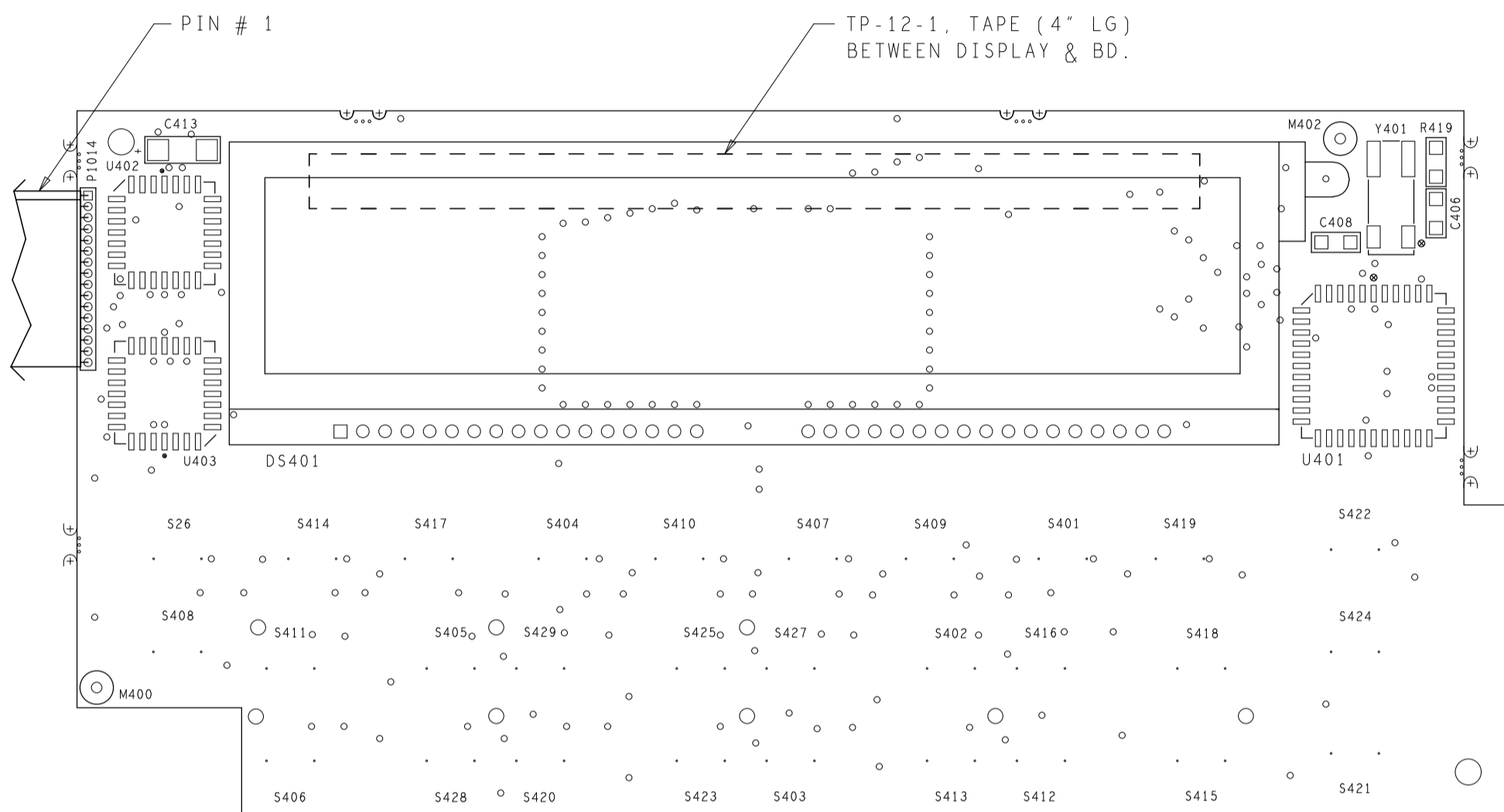

2010-112

SECONDARY (BOTTOM) SIDE COMPONENTS (SIDE -01)

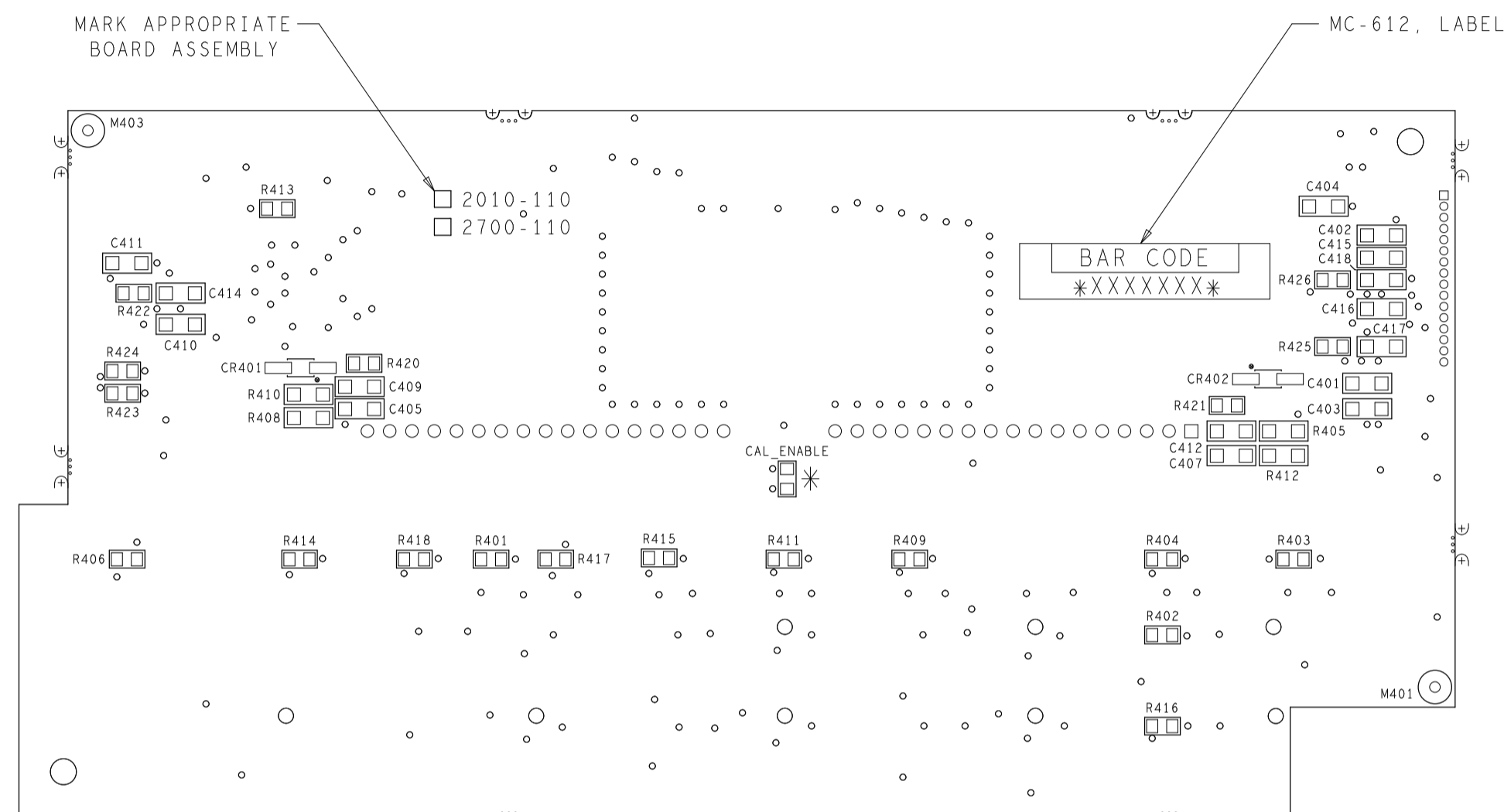

* DO NOT POPULATE: SMT: CAL_ENABLE

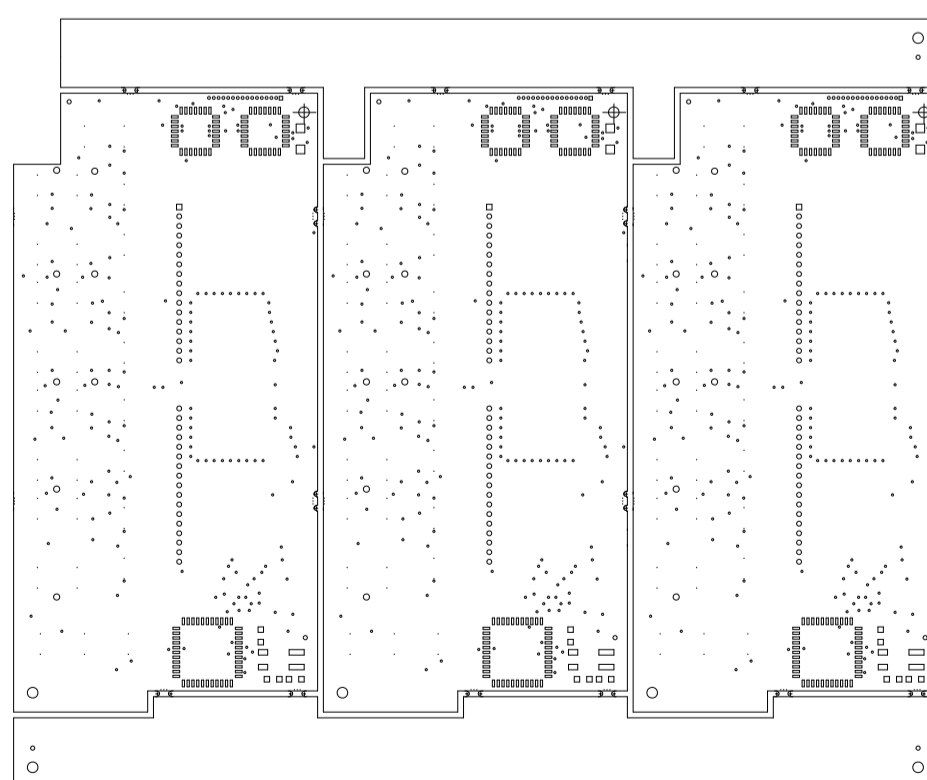

MULTI-PATTERN LAYOUT
(SCALE 1:2)
3 BOARDS PER PANEL

NOTE: FOR FURTHER COMPONENT INFORMATION, REFER TO 2010 PRODUCT STRUCTURE.

MODEL	NEXT ASSEMBLY	QTY.

USED ON

KEITHLEY KEITHLEY INSTRUMENTS INC. CLEVELAND, OHIO 44139	DIM ARE IN IN. UNLESS OTHERWISE NOTED	DATE 11/30/95	SCALE 3:2	TITLE COMPONENT LAYOUT, DISPLAY BOARD
	DIM. TOL. UNLESS OTHERWISE SPECIFIED	DRN MRS	APPR. DCL	
	XX=+.01 XXX=+.005	ANG.=+1 FRAC.=+1/64	DO NOT SCALE THIS DRAWING	C NO. 2010-110

LTR.	ECA NO.	REVISION	ENG.	DATE
H	28999	REFER TO ECA	MAH	10/24/03
J	29204	REFER TO ECA	MAH	01/26/04
J1	29510	CHG'D 0625,0650,0668 FROM TG-294 TO TG-453. CHG'D 0628,0629,0633,0634,0659,0660 FROM TG-294 TO TG-347.	TA/AS	7/16/04

PRIMARY (TOP) SIDE COMPONENTS (SIDE -04)

2182-162 (REV.D)
CONNECTOR BOARD

MC-612, LABEL

2182-102 (REV.J)
MOTHER BOARD

DO NOT POPULATE SHADED PARTS:
SMT TOP:
Q505
Q507
R143
R144
R146
R147
R630
R729

NOTE: FOR COMPONENT INFORMATION, REFER TO PRODUCT STRUCTURE.

 KEITHLEY INSTRUMENTS INC. CLEVELAND, OHIO 44139 CONFIDENTIAL PROPRIETARY	UNLESS OTHERWISE SPECIFIED: DIMENSIONS ARE IN INCHES TOLERANCES: DECIMALS ANGULAR .XX ±.01 ANG. ±1° .XXX ±.005	DATE 12/30/97	SCALE 5:4	TITLE	COMPONENT LAYOUT, MOTHER BOARD PANEL
		DRN. KEK	APPR. CM/PS		
	(EXCLUDES FINISHED HOLE SIZES AND BOARD LAYER CONSTRUCTION)	DO NOT SCALE DRAWING	C	NO.	2182-250

LTR.	ECA NO.	REVISION	ENG.	DATE
H	28999	REFER TO ECA	MAH	10/24/03
J	29204	REFER TO ECA	MAH	01/26/04
J1	29510	SEE PG.1	TA/AS	7/16/04

SECONDARY (BOTTOM) SIDE COMPONENTS (SIDE -01)

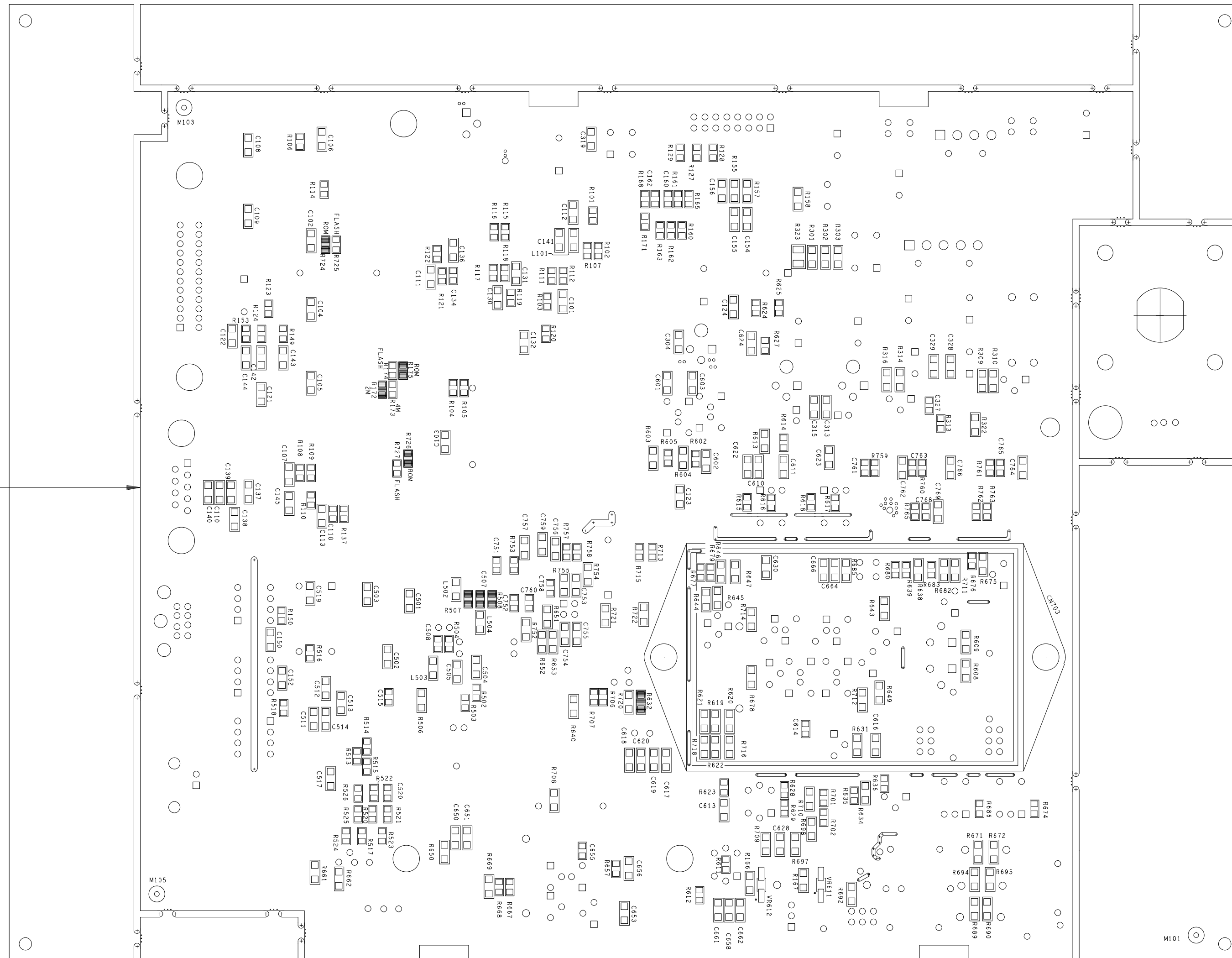

2182-162 (REV.D)
CONNECTOR BOARD

2182-102 (REV. J)
MOTHER BOARD

DO NOT POPULATE SHADED PARTS:
SMT BOTTOM:

- C507
- R117
- R150
- R500
- R633
- R720
- R726

NOTE: FOR COMPONENT INFORMATION, REFER TO PRODUCT STRUCTURE.

 KEITHLEY INSTRUMENTS INC. CLEVELAND, OHIO 44139 CONFIDENTIAL PROPRIETARY	UNLESS OTHERWISE SPECIFIED: DIMENSIONS ARE IN INCHES TOLERANCES: DECIMALS ANGULAR .XX ±.01 ANG. ±1° .XXX ±.005	DATE 12/30/97	SCALE 5:4	TITLE	COMPONENT LAYOUT, MOTHER BOARD PANEL
		DRN. KEK	APPR. CM/PS		
		DO NOT SCALE DRAWING	C	No.	2182-250

A Specifications

2182A Nanovoltmeter Specifications

VOLTS SPECIFICATIONS (20% OVER RANGE)

CONDITIONS: 1PLC with 10 reading digital filter or 5PLC with 2 reading digital filter.

CHANNEL 1 RANGE	RESOLUTION	INPUT RESISTANCE	ACCURACY: $\pm(\text{ppm of reading} + \text{ppm of range})$ (ppm = parts per million) (e.g., 10ppm = 0.001%)				TEMPERATURE COEFFICIENT 0°-18°C & 28°-50°C
			24 Hour ¹ T _{CAL} $\pm 1^\circ\text{C}$	90 Day T _{CAL} $\pm 5^\circ\text{C}$	1 Year T _{CAL} $\pm 5^\circ\text{C}$	2 Year T _{CAL} $\pm 5^\circ\text{C}$	
10.000000 mV ^{2,3,4}	1 nV	>10 GΩ	20 + 4	40 + 4	50 + 4	60 + 4	(1 + 0.5)/°C
100.00000 mV	10 nV	>10 GΩ	10 + 3	25 + 3	30 + 4	40 + 5	(1 + 0.2)/°C
1.0000000 V	100 nV	>10 GΩ	7 + 2	18 + 2	25 + 2	32 + 3	(1 + 0.1)/°C
10.000000 V	1 μV	>10 GΩ	2 + 1 ⁵	18 + 2	25 + 2	32 + 3	(1 + 0.1)/°C
100.00000 V ⁴	10 μV	10 MΩ $\pm 1\%$	10 + 3	25 + 3	35 + 4	52 + 5	(1 + 0.5)/°C
CHANNEL 2^{6,10}							
100.00000 mV	10 nV	>10 GΩ	10 + 6	25 + 6	30 + 7	40 + 7	(1 + 1)/°C
1.0000000 V	100 nV	>10 GΩ	7 + 2	18 + 2	25 + 2	32 + 3	(1 + 0.5)/°C
10.000000 V	1 μV	>10 GΩ	2 + 1 ⁵	18 + 2	25 + 2	32 + 3	(1 + 0.5)/°C

CHANNEL 1/CHANNEL 2 RATIO: Ratio accuracy = $\frac{\pm \text{channel 2 reading (accuracy channel 1 range)} + \text{channel 1 reading (accuracy channel 2 range)}}{(\text{channel 2 reading})^2}$

DELTA (hardware-triggered coordination with 24XX series or 622X series current sources for low noise R measurement): accuracy = accuracy of selected Channel 1 range plus accuracy of I source range.

DELTA measurement noise with 6220 or 6221: Typical 3nVRMS/ $\sqrt{\text{Hz}}$ (10mV range)²¹. 1 Hz achieved with 1PLC, delay = 1ms, RPT filter = 23 (20 if 50Hz)

PULSE-MODE (with 6221): line synchronized voltage measurements within current pulses from 50us to 12ms, pulse repetition rate up to 12 Hz

Pulse measurement noise: (typical RMS noise, R_{DUT}<10 ohms) $(0.009\text{ppm of range}^*) / \text{meas_time} / \sqrt{\text{pulse_avg_count}} + 3\text{nV} / \sqrt{(2 \cdot \text{meas_time} \cdot \text{pulse_avg_count})}$ for 10mV range**

* 0.0028ppm for the 100mV range, 0.0016ppm for ranges 1V and above **8nV/ $\sqrt{\text{Hz}}$ for ranges above 10mV meas_time(sec) = pulsewidth – pulse_meas_delay in 33us incr.

DC NOISE PERFORMANCE⁷ (DC NOISE EXPRESSED IN VOLTS PEAK-TO-PEAK)

Response time = time required for reading to be settled within noise levels from a stepped input, 60Hz operation.

CHANNEL 1 RESPONSE TIME	NPLC, FILTER	RANGE						
		10mV	100mV	1V	10V	100V	NMRR ⁸	CMRR ⁹
25.0 s	5, 75	6 nV	20 nV	75 nV	750 nV	75 μV	110 dB	140 dB
4.0 s	5, 10	15 nV	50 nV	150 nV	1.5 μV	75 μV	100 dB	140 dB
1.0 s	1, 18	25 nV	175 nV	600 nV	2.5 μV	100 μV	95 dB	140 dB
667 ms	1, 10 or 5, 2	35 nV	250 nV	650 nV	3.3 μV	150 μV	90 dB	140 dB
60 ms	1, Off	70 nV	300 nV	700 nV	6.6 μV	300 μV	60 dB	140 dB
CHANNEL 2^{6,10}								
25.0 s	5, 75	-	150 nV	200 nV	750 nV	-	110 dB	140 dB
4.0 s	5, 10	-	150 nV	200 nV	1.5 μV	-	100 dB	140 dB
1.0 s	1, 10 or 5, 2	-	175 nV	400 nV	2.5 μV	-	90 dB	140 dB
85 ms	1, Off	-	425 nV	1 μV	9.5 μV	-	60 dB	140 dB

VOLTAGE NOISE VS. SOURCE RESISTANCE¹¹ (DC NOISE EXPRESSED IN VOLTS PEAK-TO-PEAK)

SOURCE RESISTANCE	NOISE	ANALOG FILTER	DIGITAL FILTER
0 Ω	6 nV	Off	100
100 Ω	8 nV	Off	100
1 kΩ	15 nV	Off	100
10 kΩ	35 nV	Off	100
100 kΩ	100 nV	On	100
1 MΩ	350 nV	On	100

2182A Nanovoltmeter Specifications

Temperature (Thermocouples)¹²

(DISPLAYED IN °C, °F, OR K. ACCURACY BASED ON ITS-90, EXCLUSIVE OF THERMOCOUPLE ERRORS.)

TYPE	RANGE	RESOLUTION	ACCURACY
			90 Day/1 Year 23° ±5°C Relative to Simulated Reference Junction
J	-200 to +760°C	0.001°C	±0.2°C
K	-200 to +1372°C	0.001°C	±0.2°C
N	-200 to +1300°C	0.001°C	±0.2°C
T	-200 to +400°C	0.001°C	±0.2°C
E	-200 to +1000°C	0.001°C	±0.2°C
R	0 to +1768°C	0.1°C	±0.2°C
S	0 to +1768°C	0.1°C	±0.2°C
B	+350 to +1820°C	0.1°C	±0.2°C

OPERATING CHARACTERISTICS^{13,14} 60HZ (50HZ) OPERATION

FUNCTION	DIGITS	READINGS/s	PLCs
DCV Channel 1,	7.5	3 (1.2)	5
Channel 2,	7.5 ^{17,19}	6 (1.7)	5
Thermocouple	6.5 ^{18,19}	18 (5.5)	1
	6.5 ^{18,19,20}	45 (7.2)	1
	5.5 ^{17,19}	80 (20.9)	0.1
	4.5 ^{16,17,19}	115 (28.0)	0.01
Channel 1/Channel 2,	7.5	1.5 (1.2)	5
(Ratio),	7.5 ^{17,19}	2.3 (1.7)	5
Delta with 24XX,	6.5 ¹⁸	8.5 (5.5)	1
Scan	6.5 ^{18,20}	20 (7.2)	1
	5.5 ¹⁷	30 (20.9)	0.1
	4.5 ¹⁷	41 (28.0)	0.01
Delta with 622X	6.5	47 (40) ²²	1

SYSTEM SPEEDS^{13,15}

RANGE CHANGE TIME¹⁴: <40 ms (<50 ms).

FUNCTION CHANGE TIME¹⁴: <45 ms (<55 ms).

AUTORANGE TIME¹⁴: <60 ms (<70 ms).

ASCII READING TO RS-232 (19.2K Baud): 40/s (40/s).

MAX. INTERNAL TRIGGER RATE¹⁴: 120/s (120/s).

MAX. EXTERNAL TRIGGER RATE¹⁶: 120/s (120/s).

MEASUREMENT CHARACTERISTICS

A-D LINEARITY: 0.8ppm of reading + 0.5ppm of range.

FRONT AUTOZERO OFF ERROR: 10mV – 10V: Add ±(8ppm of reading + 500µV) for <10 minutes and ±1°C.

NOTE: Offset voltage error does not apply for Delta Mode.

AUTOZERO OFF ERROR

10mV: Add ±(8ppm of reading + 100nV) for <10 minutes and ±1°C.

100mV-100V: Add ±(8ppm of reading + 10µV) for <10 minutes and ±1°C.

NOTE: Offset voltage error does not apply for Delta Mode.

INPUT IMPEDANCE

10mV-10V: >10GΩ, in parallel with <1.5nF. (Front Filter ON)

10mV-10V: >10GΩ, in parallel with <0.5nF. (Front Filter OFF)

100V: 10MΩ±1%

DC INPUT BIAS CURRENT:

<60pA @ 23°C, -10V to 5V.

<120pA @ 23°C, 5 V to 10V.

COMMON MODE CURRENT: <50nA p-p at 50Hz or 60Hz.

INPUT PROTECTION: 150V peak to any terminal, 70V peak Channel 1 LO to Channel 2 LO.

CHANNEL ISOLATION: >10GΩ.

EARTH ISOLATION: 350V peak, >10GΩ and <150pF any terminal to earth. Add 35pF/ft with Model 2107 Low Thermal Input Cable.

2182A Nanovoltmeter Specifications

ANALOG OUTPUT

MAXIMUM OUTPUT: $\pm 1.2V$.

ACCURACY: $\pm(0.1\%$ of output + 1mV).

OUTPUT RESISTANCE: $1k\Omega \pm 5\%$.

GAIN: Adjustable from 10^9 to 10^6 . With gain set to 1, a full range input will produce a 1V output.

OUTPUT REL: Selects the value of input that represents 0V at output. The reference value can be either programmed value or the value of the previous input.

TRIGGERING AND MEMORY

WINDOW FILTER SENSITIVITY: 0.01%, 0.1%, 1%, 10%, or full scale range (none).

READING HOLD SENSITIVITY: 0.01%, 0.1%, 1%, or 10% of reading.

TRIGGER DELAY: 0 to 99 hours (1ms step size).

EXTERNAL TRIGGER DELAY: 2ms + <1ms jitter with auto zero off, trigger delay = 0.

MEMORY SIZE: 1024 readings.

MATH FUNCTIONS

Rel. Min/Max/Average/Std. Dev/Peak-to-Peak (of stored reading), Limit Test, %, and mX+b with user defined units displayed.

REMOTE INTERFACE

Keithley 182 emulation.

GPIB (IEEE-488.2) and RS-232C.

SCPI (Standard Commands for Programmable Instruments).

GENERAL SPECIFICATIONS

POWER SUPPLY: 100V/120V/220V/240V.

LINE FREQUENCY: 50Hz, 60Hz, and 400Hz, automatically sensed at power-up.

POWER CONSUMPTION: 22VA

OPERATING ENVIRONMENT: Specified for 0° to 50°C. Specified to 80% RH at 35°C.

MAGNETIC FIELD DENSITY: 10mV range 4.0s response noise tested to 500 gauss.

STORAGE ENVIRONMENT: -40° to 70°C.

WARRANTY: 3 years.

SAFETY: Complies with European Union Directive 73/23/EEC (low voltage directive); meets EN61010-1 safety standard. Installation category I.

EMC: Complies with European Union Directive 89/336/EEC (CE marking requirement), FCC part 15 class B, CISPR 11, IEC 801-2, IEC-801-3, IEC 801-4.

VIBRATION: MIL-PRF-28800E Type III, Class 5.

WARM-UP: 2.5 hours to rated accuracy.

DIMENSIONS: Rack Mounting: 89mm high x 213mm wide x 370mm deep (3.5in x 8.375in x 14.563in). Bench Configuration (with handles and feet): 104mm high x 238mm wide x 370mm deep (4.125 in x 9.375 in x 14.563 in).

SHIPPING WEIGHT: 5kg (11 lbs).

ACCESSORIES SUPPLIED

2107-4: Low Thermal Input Cable with spade lugs, 1.2m (4 ft).

User manual, service manual, contact cleaner, line cord, alligator clips.

ACCESSORIES AVAILABLE

2107-30: Low Thermal Input Cable with spade lugs, 9.1m (30 ft)

2182-KIT: Low Thermal Connector with strain relief

2188: Low Thermal Calibration Shorting Plug

2187-4: Input Cable with safety banana plugs

4288-1: Single Fixed Rack Mount Kit

4288-2: Dual Fixed Rack Mount Kit

7007-1: Shielded GPIB Cable, 1m (3.2 ft)

7007-2: Shielded GPIB Cable, 2m (6.5 ft)

7009-5: Shielded RS-232 Cable 1.5m (5 ft)

8501-1: Trigger-Link Cable 1m (3.2 ft)

8501-2: Trigger-Link Cable 2m (6.5 ft)

8502: Trigger-Link Adapter to 6 female BNC connectors

8503: Trigger-Link Cable to 2 male BNC connectors

Notes:

- Relative to calibration accuracy.
- With Analog Filter on, add 20ppm of reading to listed specification.
- When properly zeroed using REL function. If REL is not used, add 100nV to the range accuracy.
- Specifications include the use of ACAL function. If ACAL is not used, add 9ppm of reading/°C from T_{CAL} to the listed specification. T_{CAL} is the internal temperature stored during ACAL.
- For 5PLC with 2-reading Digital Filter. Use $\pm(4\text{ppm of reading} + 2\text{ppm of range})$ for 1PLC with 10-reading Digital Filter.
- Channel 2 must be referenced to Channel 1. Channel 2 HI must not exceed 125% (referenced to Channel 1 LO) of Channel 2 range selected.
- Noise behavior using 2188 Low Thermal Short after 2.5 hour warm-up, $\pm 1^\circ\text{C}$. Analog Filter off. Observation time = 10X response time or 2 minutes, whichever is less.
- For L_{SYNC} On, line frequency $\pm 0.1\%$. If L_{SYNC} Off, use 60dB.
- For $1k\Omega$ unbalance in LO lead. AC CMRR is 70dB.
- For Low Q mode On, add the following to DC noise and range accuracy at stated response time: 200nV p-p @ 25s, 500nV p-p @ 4.0s, 1.2 μV p-p @ 1s, and 5 μV p-p @ 85ms.
- After 2.5 hour warm-up, $\pm 1^\circ\text{C}$, 5PLC, 2 minute observation time, Channel 1 10mV range only.
- For Channel 1 or Channel 2, add 0.3°C for external reference junction. Add 2°C for internal reference junction.
- Speeds are for 60Hz (50Hz) operation using factory defaults operating conditions (*RST). Autorange Off, Display Off, Trigger Delay = 0, Analog Output off.
- Speeds include measurements and binary data transfer out the GPIB. Analog Filter On, 4 readings/s max.
- Auto Zero Off, NPLC = 0.01.
- 10mV range, 80 readings/s max.
- Sample count = 1024, Auto Zero Off.
- For L_{SYNC} On, reduce reading rate by 15%.
- For Channel 2 Low Q mode Off, reduce reading rate by 30%.
- Front Auto Zero Off, Auto Zero Off.
- Applies to measurements of room temperature resistances $< 10k\Omega$, Isource range $\leq 20\mu\text{A}$
- Display off, delay 1ms

B Calibration Reference

Introduction

This appendix contains detailed information on the various Model 2182 remote calibration commands, calibration error messages, and methods to detect the end of each calibration step.

[Section 2](#) of this manual covers detailed calibration procedures.

Command summary

Table B-1 summarizes Model 2182 calibration commands. These commands are covered in detail in the following paragraphs.

Table B-1

Remote calibration command summary

Command	Description
:CALibration	
:PROTeCted	
:CODE <name>	Send the code to unlock calibration. Default: 'KI002182'.
:INITiate	Required before starting any other cal steps.
:PCAL	Precal commands.*
:STEP0 <nrf>	Precal 10V input.
:STEP1 <nrf>	Precal 0V input.
:STEP2 <nrf>	Precal 1V front input.
:DC	Normal calibration commands.
:STEP1	Normal calibration short-circuit input.
:STEP2	Normal calibration open-circuit.
:STEP3 <nrf>	Normal calibration +10V input.
:STEP4 <nrf>	Normal calibration -10V input.
:STEP5	Analog output calibration.*
:DATE <string>	Set the cal date.
:DATE?	Query cal date.
:NDUE <string>	Set the due date for the next cal.
:NDUE?	Query cal due date.
:SAVE	Save cal constants.**
:LOCK	Lock out calibration.
:LOCK?	Query lock status.
:DATA?	Query cal constants (unlocking not required).
:COUNt?	Query cal count.

*Factory cal only. Send :DIAG:KEIT:CAL:UNLOCK to enable.

**Calibration data will *not* be saved if an error occurred.

Default calibration constants and tolerances

Default calibration constants and tolerances for the Model 2182 are listed in [Table B-2](#). The tolerances for user-entered values are expressed as a percentage (10%). For example, for the +10V calibration, the calibration signal can be +9V to +11V. The rest of the tolerances are expressed as full-scale values. Most are 10% of the default value.

The tolerance for the ACAL temperature constant (ACalTemp) is $\pm 30^{\circ}\text{C}$ of the default (which is 30°C). Therefore, valid ACAL can be performed for temperatures from 0 to 60°C .

Table B-2

Default calibration constants and tolerances

Cal constant name	Default cal constant	Cal constant tolerance	Typical constants	Description
usr_10vfs	+10e+0	10%	1.0000000E+01	+10V value entered by user.
usr_m10vfs	-10e+0	10%	-1.0000000E+01	-10V value entered by user.
usr_100vfs	+100e+0	10%	1.0000000E+02	+100V value entered by user (not used).
aper_corr_1plc	+1.44e-1	1.44e-2	1.4449467E-01	Gain-aperture correction, 1PLC.
aper_corr_5plc	+1.44e-1	1.44e-2	1.4449382E-01	Gain-aperture correction, 5PLC.
c10mvz	-6e-6	2e-2	5.3548538E-06	Zero, 10mV range.
c1vz	-6e-6	8e-5	8.5682575E-08	Zero, +1V.
c10vz	-4e-7	1e-4	-2.9889257E-07	Zero, +10V.
c100vz	-6e-6	8e-5	-2.6752717E-07	Zero, +100V.
c10vratz_ch2hi	-6.00e-6	6.00e-5	3.4445513E-08	Zero, +10V, channel 2 high.
c10vratz	-4e-6	8e-5	6.9316616E-07	Zero, +10V, channel 2 low.
c10vratz_LOW_Q	-4e-6	8e-5	-3.5030445E-07	Zero, +10V, channel 2 low-pumpout mode.
c10vfs	+1.4231e+0	1.44e-1	1.4294341E+00	Full scale, +10V.
cm10vfs	-1.44e+0	1.44e-1	-1.4294396E+00	Full scale, -10V.
cFE_B_0_DIV100	-6.00e-6	6.00e-5	-2.3740633E-07	Background zero x1/100 gain.
c100vfs	-6.00e-6	1.00e-3	-4.7622696E-04	Check for voltage applied at start of full ACAL.
cm100vfs	-1.44e-1	1.44e-2	-1.4400000E-01	Full scale, -100V (not used; no 100V cal step).
cFE_B_7_DIV100	+1.00e-2	1.00e-3	9.9931261E-03	ACAL 7V reference, x1/100 gain. For 100V range.
cFE_B_7_1	+1.00e+0	1.00e-1	9.9988576E-01	ACAL 7V reference, x1 gain. For 100V range.
cFE_B_0_1_100V	-6.00e-6	6.00e-5	-6.0000000E-06	ACAL, 100V divider gain. Not used.
cFE_B_1_1	+1.44e-1	1.44e-2	1.4449498E-01	ACAL 1V reference, x1 gain. For 10mV range.
cFE_B_1_10	+1.44e+0	8.64e-1	1.4436776E+00	ACAL 1V reference, x10 gain. For 10mV range.
cFE_B_0_10	+1.44e-1	1.44e-2	1.4294286E-01	c1V_Icorr_off @ 1PLC
cFE_B_P1_10	+1.44e-1	8.64e-2	1.5625974E-01	ACAL 0.1V reference, x10 gain. For 10mV range.
cFE_B_P1_100	+1.44e+0	2.88e-1	1.5614776E+00	ACAL 0.1V reference, x100 gain. For 10mV range.
cFE_B_0_100	+1.44e-1	1.44e-2	1.4294303E-01	c1v_Icorr_on @ 1PLC
ACalTemp	30.0	±30	3.2249547E+01	Temperature (in °C) of unit during ACAL.
caoutvz	0.00025	0.025	2.8907327E-04	Analog output, DAC at 0.
caoutv32000	-1.667e-1	3.2e-2	-1.7226908E-01	Analog output, DAC at +32000.
caoutvm32000	1.667e-1	3.2e-2		Analog output, DAC at -32000.

Miscellaneous commands

Miscellaneous commands are those commands that perform such functions as saving calibration constants, locking out calibration, and programming date parameters.

:CODE

(:CALibration:PROTeCted:CODE)

Purpose	To unlock calibration so that you can perform the calibration procedures.
Format	:cal:prot:code '<code>'
Parameter	Up to a 8-character string including letters and numbers.
Description	The :CODE command sends the code and enables calibration when performing these procedures via remote. The correct code must be sent to the unit before sending any other calibration command. The default remote code is KI002182.

NOTES *The :CODE command should be sent only once before performing calibration. Do not send :CODE before each calibration step.*

To change the code, first send the present code, then send the new code.

The code parameter must be enclosed in single quotes.

If you change the first two characters of the code to something other than "KI", you will not be able to unlock calibration from the front panel.

Example :CAL:PROT:CODE 'KI002182' Send default code of KI002182.

:COUNT?

(:CALibration:PROTeCted:COUNT?)

Purpose	To request the number of times the Model 2182 has been calibrated.
Format	:cal:prot:count?
Response	Number of times calibrated.
Description	The :COUNT? query may be used to determine the total number of times the Model 2182 has been calibrated.
Example	:CAL:PROT:COUNT? Request calibration count.

:LOCK

(:CALibration:PROTected:LOCK)

Purpose	To lock out calibration.
Format	:cal:prot:lock
Query	:cal:prot:lock?
Response	0 Calibration unlocked 1 Calibration locked
Description	The :LOCK command allows you to lock out calibration after completing those procedures. Thus, :LOCK performs the opposite of sending the code with the :CODE command. The :LOCK? query returns calibration lock status.

NOTE To unlock calibration, send the :CODE command with the appropriate password.

Purpose	To unlock calibration so that you can perform the calibration procedures.
Example	:CAL:PROT:LOCK Lock out calibration

:SAVE

(:CALibration:PROTected:SAVE)

Purpose	To save calibration constants in EEROM after the calibration procedure.
Format	:cal:prot:save
Description	The :SAVE command stores internally calculated calibration constants derived during calibration in EEROM. EEROM is non-volatile memory, and calibration constants will be retained indefinitely once saved. Generally, :SAVE is sent after all other calibration steps (except for :LOCK).

NOTE Calibration will be only temporary unless the :SAVE command is sent to permanently store calibration constants. Calibration data will not be saved if any errors occurred.

Example	:CAL:PROT:SAVE Save calibration constants
----------------	--

:DATE

(:CALibration:PROTeCted:DATE)

Purpose	To program the calibration date.
Format	:cal:prot:date <year>, <month>, <day>
Parameters	<year> = 1997 to 2096 <month> = 1 to 12 <day> = 1 to 31
Query	:cal:prot:date?
Response	<year>, <month>, <day>
Description	The :DATE command allows you to store the calibration date in instrument EEROM for future reference. You can read back the date from the instrument by using the :DATE? query.

NOTE The year, month, and day parameters must be delimited by commas.

Example :CAL:PROT:DATE 1997,11,20 Send cal date (11/20/97).

:NDUE

(:CALibration:PROTeCted:NDUE)

Purpose	To send the next calibration due date to the instrument.
Format	:cal:prot:ndue <year>, <month>, <day>
Parameters	<year> = 1997 to 2096 <month> = 1 to 12 <day> = 1 to 31
Query	:cal:prot:ndue?
Response	<year>, <month>, <day>
Description	The :NDUE command allows you to store the date when calibration is next due in instrument memory. You can read back the next due date by using the :NDUE? query.

NOTE The next due date parameters must be delimited by commas.

Example :CAL:PROT:NDUE 1998,11,20 Send due date (11/20/98).

:DATA?

(:CALibration:PROTeCted:DATA?)

Purpose	To request the calibration constants for the active range.
Format	:cal:prot:data?
Response	Comma-separated ASCII floating-point constants
Description	The :CAL:PROT:DATA? query requests the calibration constants for the active range. The returned constants are in ASCII floating-point format delimited by commas.

NOTE To request the appropriate constants choose the desired range, and send the :DATA? query.

Example :CAL:PROT:DATA? Request cal constants.

Calibration step commands

:DC

:CALibrate:PROTeCted:DC:STEPn

Purpose	To perform various calibration steps.
Format	:cal:prot:dc:stepn
Parameters	See Table B-3 .
Description	The :DC commands perform the various calibration steps summarized in Table B-3 . All commands except :STEP5 are part of the normal calibration procedure. See Section 2 for details on performing the calibration steps.

NOTE The appropriate calibration signal must be connected to the input jack before sending the corresponding :STEP command.

Example :CAL:PROT:DC:STEP3 10 Perform normal cal 10V step.

Table B-3
Calibration steps

Calibration step command	Description
:CAL:PROT:DC:STEP1	Low thermal short.
:CAL:PROT:DC:STEP2	Open-circuit input.
:CAL:PROT:DC:STEP3 10	+10V calibration
:CAL:PROT:DC:STEP4 -10	-10V calibration
:CAL:PROT:DC:STEP5	Analog output*

* Factory calibration only. Send :DIAG:KEIT:CAL:UNLOCK to enable.

Precalibration commands

:PCAL

:CALibrate:PROTeCted:PCAL:STEPn

NOTE *Precal :STEP commands are intended to be one-time manufacturing calibration steps, and are only allowed if the STEP key was held in at power-up.*

Purpose	To perform various precal steps.
Format	:cal:prot:pcal:stepn
Parameters	See Table B-4 .
Description	The :PCAL commands perform the various precalibration steps summarized in Table B-4 . All these steps are part of factory calibration and need not normally be performed in the field. See Section 2 for details on performing the calibration steps.

NOTES *The appropriate calibration signal must be connected to the input jack before sending the corresponding :STEP command.*

Factory calibration is enabled by sending :DIAG:KEIT:CAL:UNLOCK.

Example :CAL:PROT:PCAL:STEP3 1 Perform precal 1V step.

Table B-4
Precal steps

Calibration step command	Description
:CAL:PROT:PCAL:STEP0 10	10V precal
:CAL:PROT:PCAL:STEP1 0	0V precal
:CAL:PROT:PCAL:STEP2 1	1V precal

:CALibrate:PROTeCted:PCAL:DATA?

Purpose	Query precal constants.
Format	:cal:prot:pcal:stepn
Response	Two ASCII values separated by a comma.
Description	The :CAL:PROT:PCAL:DATA? query requests the precalibration constants. Two values are returned; the Linearity Correction Flag (1 or 0), and the offset DAC value. Note that unlocking with STEP key is not required for this query command.

Example :CAL:PROT:PCAL:DATA? Request precalibration constants.

Detecting calibration errors

If an error occurs during any calibration step, the Model 2182 will generate an appropriate error message. Several methods to detect calibration errors are discussed below.

Reading the error queue

As with other Model 2182 errors, any calibration errors will be reported in the error queue. (You can read the error queue by using the :SYST:ERR? query.)

Error summary

Table B-5 summarizes calibration errors.

Table B-5
Calibration errors

Error number	Error message
+400	"10m vdc zero error"
+401	"1 vdc zero error"
+402	"10 vdc zero error"
+403	"100 vdc zero error"
+404	"10 vdc full scale error"
+405	"-10 vdc full scale error"
+406	"100 vdc full scale error"
+408	"10 vdc ch2 high zero error"
+409	"10 vdc ch2 low zero error"
+410	"B_7_div100 ACAL error"
+411	"B_0_div100 ACAL error"
+412	"B_7_1 ACAL error"
+413	"B_0_1 ACAL error"
+414	"B_1_1 ACAL error"
+415	"B_1_10 ACAL error"
+416	"ACAL not open-circuit"
+417	"B_P1_10 ACAL error"
+418	"B_P1_100 ACAL error"
+419	"B_0_10 ACAL error"
+420	"Analog output zero error"
+421	"Analog positive gain error"
+422	"Analog negative gain error"
+423	"B_0_100 ACAL error"

Table B-5
Calibration errors (cont.)

Error number	Error message
+430	"Precal selection error"
+431	"Precal offset DAC zero error"
+432	"ACAL Temperature error"
+438	"Date of calibration not set"
+439	"Next date of calibration not set"
+440	"Gain-aperture correction error"
+449	"10 vdc ch2 Low-Q zero error"
+500	"Calibration data invalid"

Status byte EAV (Error Available) bit

Whenever an error is available in the error queue, the EAV (Error Available) bit (bit 2) of the status byte will be set. Use the *STB? query to obtain the status byte, then test bit 2 to see if it is set. If the EAV bit is set, an error has occurred, and you can use the appropriate error query to read the error and at the same time clear the EAV bit in the status byte.

Generating an SRQ on error

To program the instrument to generate an IEEE-488 bus SRQ (Service Request) when an error occurs, send the following command: *SRE 4. This command will enable SRQ when the EAV bit is set. You can then read the status byte and error queue as outlined above to check for errors and to determine the exact nature of the error.

Detecting calibration step completion

When sending remote calibration commands, you must wait until the instrument completes the current operation before sending another command. You can use either `*OPC?` or `*OPC` to help determine when each calibration step is completed.

Using the `*OPC` command

The `*OPC` (operation complete) command can be used to detect the completion of a calibration step. The following command sequence shows how to use `*OPC` with a calibration step:

<code>*CLS</code>	' Clears all event registers and error queue.
<code>*ESE 1</code>	' Enables OPC bit in standard event register.
<code>*SRE 32</code>	' Enables ESB bit in status byte register.
<code>:CAL:PROT:STEP1;*OPC</code>	' Perform calibration step and send <code>*OPC</code> .

After sending `*OPC`, use the serial poll (SPE, SPD) sequence to monitor the RQS bit of the serial poll (status) byte of the Model 2182. When the calibration step is completed, a service request will be generated and set the RQS bit, indicating that the next calibration step can now be performed.

NOTE *After a service request is generated, it must be cleared by reading the event status register by sending the following command:*

`*ESR?`

C Calibration Program

Introduction

This appendix includes a calibration program written in BASIC to help you to field calibrate the Model 2182. Refer to [Section 2](#) for more details on calibration procedures, equipment, and connections. [Appendix B](#) covers calibration commands in detail.

Computer hardware requirements

The following computer hardware is required to run the calibration programs:

- IBM PC compatible computer.
- Keithley KPC-488.2, KPS-488.2, or KPC-488.2AT, or CEC PC-488 IEEE-488 interface for the computer.
- Two shielded IEEE-488 connecting cables (Keithley Model 7007).

Software requirements

In order to use the calibration programs, you will need the following computer software:

- Microsoft QBasic (supplied with MS-DOS 5.0 or later).
- MS-DOS version 5.0 or later.
- HP-style Universal Language Driver, CECHP.EXE (supplied with Keithley and CEC interface cards listed above).

Calibration equipment

The following calibration equipment is required:

- Fluke 5700A calibrator
- Low thermal input cable
- Low thermal shorting plug

See [Section 2](#) for detailed equipment specifications.

General program instructions

1. With the power off, connect the Model 2182 and the calibrator to the IEEE-488 interface of the computer. Be sure to use shielded IEEE-488 cables for bus connections.
2. Turn on the computer, the Model 2182, and the calibrator. Allow the Model 2182 and the multimeter to warm up for at least 2-1/2 hours before performing calibration.
3. Make sure the Model 2182 is set for its default primary address of 7.
4. Make sure the calibrator primary address is set at 4.
5. Make sure that the computer bus driver software (CECHP.EXE) is properly initialized.
6. Enter the QBasic editor, and type in the program below.
7. Check thoroughly for errors, then save it using a convenient filename.
8. Run the program, and follow the prompts on the screen to perform calibration. For test connections, refer to the following figures in [Section 2](#):
 - Low thermal shorting plug connections: [Figure 2-1](#).
 - Calibrator connections: [Figure 2-2](#).

Program C-1

Model 2182 calibration program

```
' Model 2182 calibration program for use with the Fluke 5700A calibrator.
' Rev. 1.0, 8/20/97
OPEN "IEEE" FOR OUTPUT AS #1           ' Open IEEE-488 output path.
OPEN "IEEE" FOR INPUT AS #2           ' Open IEEE-488 input path.
PRINT #1, "INTERM CRLF"               ' Set input terminator.
PRINT #1, "OUTTERM LF"                ' Set output terminator.
PRINT #1, "REMOTE 4 7"                ' Put 2182, 5700A in remote.
PRINT #1, "CLEAR"                     ' Send DCL.
PRINT #1, "OUTPUT 7;:SYST:PRES;*CLS"  ' Initialize 2182.
PRINT #1, "OUTPUT 7;*ESE 1;*SRE 32"  ' Enable OPC and SRQ
PRINT #1, "OUTPUT 4;*RST;*CLS;STBY"  ' Reset 5700A calibrator.
C$ = ":CAL:PROT:DC:"                  ' 2182 partial command header.
'
CLS                                    ' Clear CRT.
PRINT "Model 2182 Calibration Program"
PRINT #1, "OUTPUT 7;:CAL:PROT:CODE 'KI002182'" ' Send KI002182 cal code.
PRINT #1, "OUTPUT 7;:CAL:PROT:INIT"     ' Initiate calibration.
GOSUB ErrCheck
RESTORE CmdList
'
FOR I = 1 TO 4                          ' Loop for all cal points.
READ Msg$, Cmd$                          ' Read message, cal strings.
SELECT CASE I                             ' Select cal sequence.
    CASE 1, 2
        PRINT Msg$
        GOSUB KeyCheck
```



```

CASE 3
    PRINT "Connect calibrator to CHANNEL 1 input."
    PRINT "Wait 2 minutes."
    GOSUB KeyCheck
    PRINT #1, "OUTPUT 4;EXTSENSE OFF"
    PRINT #1, "OUTPUT 4;"; Msg$
    PRINT #1, "OUTPUT 4;OPER"
CASE 4, 5
    PRINT #1, "OUTPUT 4;"; Msg$
    PRINT #1, "OUTPUT 4;OPER"
END SELECT
IF I > 2 THEN GOSUB Settle
PRINT #1, "OUTPUT 7;"; C$; Cmd$; ";*OPC" ' Send cal command to 2182.
GOSUB CalEnd ' Wait until cal step ends.
GOSUB ErrCheck ' Check for cal error.
NEXT I
'
PRINT #1, "OUTPUT 4;STBY"
LINE INPUT "Enter calibration date (yyyy,mm,dd): "; D$
PRINT #1, "OUTPUT 7;:CAL:PROT:DATE "; D$
LINE INPUT "Enter calibration due date (yyyy,mm,dd): "; D$
PRINT #1, "OUTPUT 7;:CAL:PROT:NDUE "; D$
PRINT #1, "OUTPUT 7;:CAL:PROT:SAVE" ' Save calibration constants.
GOSUB ErrCheck
PRINT #1, "OUTPUT 7;:CAL:PROT:LOCK" ' Lock out calibration.
PRINT "Calibration completed."
PRINT #1, "OUTPUT 7;:SYST:PRES"
END
'
KeyCheck: ' Check for key press routine.
WHILE INKEY$ <> "": WEND ' Flush keyboard buffer.
PRINT : PRINT "Press any key to continue (ESC to abort program).".
DO: I$ = INKEY$: LOOP WHILE I$ = ""
IF I$ = CHR$(27) THEN GOTO EndProg ' Abort if ESC is pressed.
RETURN
'
CalEnd: ' Check for cal step completion.
PRINT "Performing calibration step #"; I
DO: PRINT #1, "SRQ?" ' Request SRQ status.
INPUT #2, S ' Input SRQ status byte.
LOOP UNTIL S ' Wait for operation complete.
PRINT #1, "OUTPUT 7;*ESR?" ' Clear OPC.
PRINT #1, "ENTER 7"
INPUT #2, S
PRINT #1, "SPOLL 7" ' Clear SRQ.
INPUT #2, S
RETURN
'

```

```
ErrCheck:                                     ' Error check routine.
PRINT #1, "OUTPUT 7;:SYST:ERR?"              ' Query error queue.
PRINT #1, "ENTER 7"
INPUT #2, E, Err$
IF E <> 0 THEN BEEP: PRINT Err$: GOTO ErrCheck ' Display error.
RETURN
'
Settle:                                       ' Calibrator settling routine.
DO: PRINT #1, "OUTPUT 4;ISR?"                 ' Query status register.
PRINT #1, "ENTER 4"
INPUT #2, S
LOOP UNTIL (S AND &H1000)                     ' Test settle bit.
RETURN
'
EndProg:                                      ' Close files, end program.
BEEP: PRINT "Calibration aborted."
PRINT #1, "OUTPUT 4;STBY"
PRINT #1, "OUTPUT 7;:SYST:PRES"
PRINT #1, "LOCAL 4 7"
CLOSE
END
'
CmdList:
DATA "Connect low-thermal short to input jack, wait 3 minutes.,""STEP1"
DATA "Disconnect low-thermal short from input jack.,""STEP2"
DATA "OUT 10 V,0 HZ","STEP3 10"
DATA "OUT -10 V","STEP4 -10"
```

Index

CODE [B-6](#)
COUNT? [B-6](#)
DATE [B-8](#)
DC [B-9](#)
LOCK [B-7](#)
NDUE [B-8](#)
PCAL [B-10](#)
SAVE [B-7](#)

A

Aborting calibration [2-6](#)
Analog circuit checks [4-13](#)
Analog circuitry [4-7](#)
Analog output accuracy [1-10](#)
Analog signal switching states [4-14](#)
Assembly drawings [5-3](#)
Auto-calibration (ACAL) [1-4](#)

B

Board installation [5-9](#)

C

Calibration [2-1](#)
Calibration considerations [2-3](#)
Calibration cycle [2-3](#)
Calibration equipment [C-2](#)
Calibration errors [2-5](#)
Calibration menu [2-3](#)
Calibration Program [C-1](#)
Calibration Reference [B-1](#)
Calibration step commands [B-9](#)
Case cover removal [5-4](#)
Changing trigger link lines [5-7](#)
Command summary [B-3](#)
Component layouts [6-2](#)
Computer hardware requirements [C-2](#)

D

DATA? [B-9](#)
Default calibration constants and tolerances [B-4](#)
Detecting calibration errors [B-11](#)
Detecting calibration step completion [B-13](#)
Digital circuit checks [4-12](#)

Digital circuitry [4-6](#)
Disassembly [5-1](#), [5-4](#)
DISP test [4-3](#)
Display board [4-5](#)
Display board checks [4-10](#)

E

Environmental conditions [1-2](#), [2-2](#)
Error summary [B-11](#)

F

Factory calibration [2-12](#)
Factory service [6-2](#)
Front panel calibration [2-6](#)
Front panel disassembly [5-5](#)
Front panel tests [4-3](#)

G

General program instructions [C-3](#)
Generating an SRQ on error [B-12](#)

H

Handling and cleaning [5-2](#)
Handling PC boards [5-2](#)

I

Instrument reassembly [5-9](#)

K

KEY test [4-3](#)

L

Line fuse replacement [3-2](#)
Line power [1-3](#)
Line voltage selection [3-3](#)

M

Main CPU firmware replacement [5-6](#)
Miscellaneous commands [B-6](#)
Motherboard removal [5-5](#)

N

No comm link error [4-16](#)
Normal calibration [2-6](#)

O

Ordering information [6-2](#)

P

- Parts lists [6-2](#)
- Performance Verification [1-1](#)
- Performing the verification test procedures [1-5](#)
- Power module connections [5-9](#)
- Power module removal [5-8](#)
- Power supply [4-4](#)
- Power supply checks [4-11](#)
- Power transformer removal [5-8](#)
- Power-on self-test [4-3](#)
- Precalibration commands [B-10](#)
- Principles of operation [4-4](#)

R

- Reading the error queue [B-11](#)
- Recommended calibration equipment [2-6](#)
- Recommended test equipment [1-3](#), [2-12](#)
- Remote calibration [2-10](#)
- Remote factory calibration [2-13](#)
- Removing power components [5-8](#)
- Repair considerations [4-2](#)
- Replaceable Parts [6-1](#)
- Restoring factory defaults [1-4](#)
- Routine Maintenance [3-1](#)

S

- Software requirements [C-2](#)
- Solder repairs [5-2](#)
- Specifications [A-1](#)
- Static sensitive devices [5-3](#)
- Status byte EAV (Error Available) bit [B-12](#)

T

- Temperature and relative humidity [2-2](#)
- Temperature measurement accuracy [1-8](#)
- Test considerations [1-5](#)
- Test summary [1-5](#)
- Troubleshooting [4-1](#), [4-10](#)

U

- Using the *OPC command [B-13](#)

V

- Verification procedures [1-6](#)
- Verification reading limits [1-4](#)
- Verification test requirements [1-2](#)
- Voltage measurement accuracy [1-6](#)

W

- Warm-up period [1-3](#)

Model No. _____ **Serial No.** _____ **Date** _____

Name and Telephone No. _____

Company _____

List all control settings, describe problem and check boxes that apply to problem. _____

Intermittent Analog output follows display Particular range or function bad; specify

IEEE failure Obvious problem on power-up Batteries and fuses are OK

Front panel operational All ranges or functions are bad Checked all cables

Display or output (check one)

Drifts Unable to zero
 Unstable Will not read applied input
 Overload

Calibration only Certificate of calibration required

Data required

(attach any additional sheets as necessary)

Show a block diagram of your measurement system including all instruments connected (whether power is turned on or not). Also, describe signal source.

Where is the measurement being performed? (factory, controlled laboratory, out-of-doors, etc.)

What power line voltage is used? _____ Ambient temperature?°F _____

Relative humidity? _____ Other? _____

Any additional information. (If special modifications have been made by the user, please describe.)

Be sure to include your name and phone number on this service form.

Specifications are subject to change without notice.
All Keithley trademarks and trade names are the property of Keithley Instruments, Inc.
All other trademarks and trade names are the property of their respective companies.

KEITHLEY

A G R E A T E R M E A S U R E O F C O N F I D E N C E

Keithley Instruments, Inc.

Corporate Headquarters • 28775 Aurora Road • Cleveland, Ohio 44139 • 440-248-0400 • Fax: 440-248-6168 • 1-888-KEITHLEY • www.keithley.com