

OEM

N813_DC-B (MBL)

**TRANSLATION OF ORIGINAL
OPERATING AND INSTALLATION
INSTRUCTION
ENGLISH**

DIAPHRAGM PUMP

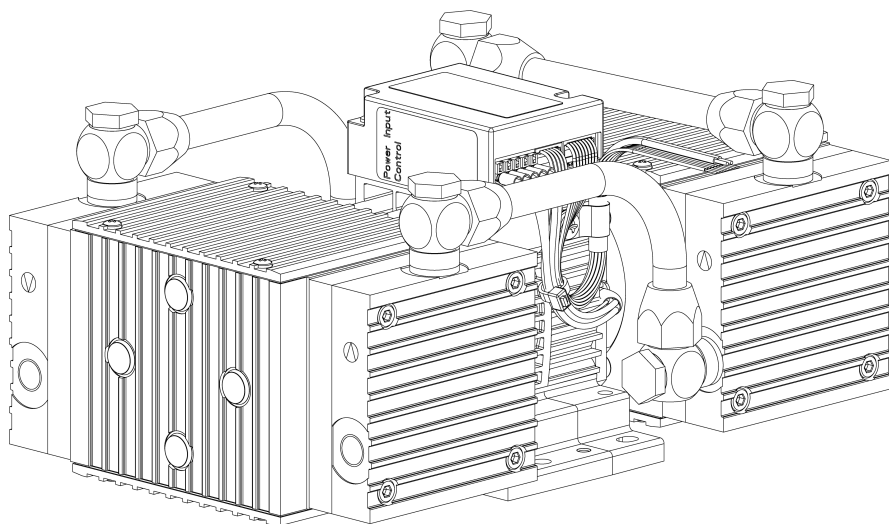

Notice!

Before operating the pump and accessories, read and observe the operating and installation instructions as well as the safety information!

Contents

1	About this document	3
1.1	Using the operating and installation instructions.....	3
1.2	Exclusion of liability.....	3
1.3	Symbols and markings.....	4
2	Safety.....	6
2.1	Personnel and target group	6
2.2	Responsibility of the operator	7
2.3	Working in a safety conscious manner	7
2.4	Operating conditions	8
2.5	Media	8
2.6	Use.....	9
2.7	Directives and standards	10
2.8	Customer service and repair.....	11
2.9	Disposal	11
3	Technical data.....	12
3.1	Technical data.....	12
4	Product description	15
5	Transport.....	18
	General	18
6	Installation and connection.....	20
6.1	Installing the pump.....	20
6.2	Electrical connection	23
6.3	Pneumatic connection.....	28
7	Operation	30
7.1	General	30
7.2	Information on switching the pump on and off	33
7.3	DC-B control functions	33
8	Servicing	40
8.1	Servicing schedule.....	41
8.2	Cleaning.....	41
8.3	Replacing diaphragm and valves.....	42
9	Spare parts and accessories.....	49
9.1	Spare parts	49
9.2	Accessories.....	49
10	Troubleshooting	50
11	Returns.....	55

1 About this document

1.1 Using the operating and installation instructions

The operating and installation instructions are part of the pump.

- In the event of uncertainties with regard to the content of the operating and installation instructions, please contact the manufacturer (contact data: see www.knf.com). Please have the type and serial number of the pump ready.
- Read the operating and installation instructions before you commission the pump.
- Give the operating and installation instructions only completely and unchanged to the next owner.
- Keep the operating and installation instructions within reach at all times.

Project pumps For customer-specific project pumps (pump models that begin with "PJ" or "PM"), there may be deviations from these operating and installation instructions.

- For project pumps, also observe the agreed specifications.

Optional contents Project-specific options may be included in the operating and assembly instructions. These are marked with "Optional". It is also possible that project-specific deviations are not included in the operating and assembly instructions.

1.2 Exclusion of liability

The manufacturer assumes no liability for damages and malfunctions resulting from failure to observe the operating and installation instructions.

The manufacturer assumes no liability for damages and malfunctions resulting from changes or modifications to the device and improper handling.

The manufacturer assumes no liability for damages and malfunctions resulting from impermissible spare parts and accessories.

1.3 Symbols and markings

Warning notice



A notice that warns you of danger is located here.

Possible consequences of a failure to observe the warning notice are specified here. The signal word, e.g., Warning, indicates the danger level.

→ Measures for avoiding the danger and its consequences are specified here.

Danger levels

Signal word	Meaning	Consequences if not observed
DANGER	warns of immediate danger	Death or serious injury or serious damage will result.
WARNING	warns of possible danger	Death, serious injury or serious damage is possible.
CAUTION	warns of a possibly dangerous situation	Minor injury or damage is possible.
NOTICE	Warns of possible damage	Damage is possible.

Tab. 1: Danger levels







Other notices and symbols

→ An activity to be carried out is specified here (a step).

1. The first step of an activity to be carried out is specified here.
Other sequentially numbered steps follow.

i This symbol indicates important information.

Explanation of pictograms

Pictogram	Meaning
	General warning symbol
	Warning of hot surface
	Warning of electrical voltage
	Warning of poisonous substances
	Warning of hand injuries through crushing
	Observe the operating instructions
	General mandatory sign

Tab.2: Explanation of pictograms

2 Safety

i Observe the safety notices in Chapters 6 *Installation and connection* [▶ 20] and 7 *Operation* [▶ 30].

2.1 Personnel and target group

Personnel Make sure that only specially trained and instructed personnel work on the pumps. This applies, in particular, to mounting, connection and servicing work.

Make sure that the personnel have read and understood the operating instructions, particularly the chapter on safety.

Target group

Target group	Definition
User	Employee
Specialized personnel	Specialized personnel are personnel who - have relevant professional training in the field covered in the particular section of text; - have current knowledge of the field covered in the particular section of text.

Tab.3: Target group

Who-does-what matrix

Lifecycle phase	User	Specialized personnel
Transport		X
Mounting		X
Connection		X
Commissioning	X	X
Operation	X	X
Servicing		X
Troubleshooting		X
Disposal		X

Tab.4: Who-does-what matrix

2.2 Responsibility of the operator

The pumps are produced in accordance with the generally recognized rules of engineering, as well as the occupational health, safety and accident prevention regulations. Nevertheless, dangers can arise during their use that lead to injuries to the user or third parties or to damage to the pump or other property.

Only use the pumps in perfect technical condition, for their intended use, safely and with an awareness of the dangers and in observation of the operating and installation instructions.

The components that are to be connected to the pumps must be designed according to the pneumatic data of the pumps.

When connecting the pumps to the electrical power, observe the corresponding safety rules.

Make sure that no hazardous situation, physical harm or impairment of the pump can occur.

Operating parameters

Only operate and install the pump under the operating parameters and operating conditions described in Chapters 2.4 *Operating conditions* [▶ 8] and 3 *Technical data* [▶ 12].

2.3 Working in a safety conscious manner

Observe the regulations on accident prevention and safety during all work on the pumps and during operation.

Avoid contact with the pump heads and housing parts because the pump heats up during operation.

When working on the pump, make sure that the pump is disconnected from mains and without power.

When connecting the pump to the electrical mains, observe the corresponding safety rules.

Ensure that no hazards arise from gas flowing when gas connections are open, from the effects of noise or from hot, corrosive, dangerous and environmentally hazardous gases.

Make sure that an EMC-compliant installation of the pump is ensured at all times to prevent the occurrence of dangerous situations.

2.4 Operating conditions

Only use the pump in perfect technical condition, for its intended purpose, safely and with an awareness of the dangers and in observation of the operating instructions.

Only install and operate the pumps in accordance with the operating parameters and conditions described in Chapter 3 *Technical data* [▶ 12].

Only pumps that are fully assembled and in the condition as delivered may be operated.

Make sure that the installation location is dry and that the pump is protected from rain, splash water, gushing water, dripping water and other contamination.

Check the tightness of the connections between the pipes of the application and the pump (or the connection of the pump) at regular intervals. Leaky connections carry the risk of releasing dangerous gases and vapors from the pump system.

2.5 Media

Requirements of pumped media	<p>Before transferring a medium, check whether the medium can be transferred without risk in the specific application.</p> <p>Take note of any change in the state of matter (condensation, crystallization).</p> <p>Before using a medium, check the compatibility of the media-contacting components (see 3 <i>Technical data</i> [▶ 12]) with the medium.</p> <p>Risk of dangerous gas mixtures during pump operation if diaphragm breaks: Depending on the medium being transferred, breakage of the diaphragm can result in a dangerous mixture if the medium mixes with the air in the compressor housing or the surroundings.</p> <p>Only transfer gases that remain stable under the pressures and temperatures that arise in the pump.</p>
Handling of hazardous media	<p>Upon breakage of the diaphragm and/or leaks, the transferred medium mixes with the air in the surroundings and/or in the pump housing.</p> <p>Make sure that a dangerous situation cannot arise as a result.</p> <p>When pumping hazardous media, observe the safety regulations for the handling of said media.</p>

- Handling of combustible media
- Note that the pump is not designed to be explosion-proof.
- Make certain that the temperature of the medium is always sufficiently below the ignition temperature of the medium so as to prevent ignition or explosion. This also applies for abnormal operating situations.
- Note that the temperature of the medium increases when the pump compresses the medium.
- Therefore, make certain that the temperature of the medium also remains sufficiently below the ignition temperature of the medium even when it is compressed to the maximum permissible operating pressure of the pump. The maximum permissible operating pressure of the pump is stated in Chapter 3 *Technical data* [▶ 12].
- Make certain that the permissible ambient temperature (see 3 *Technical data* [▶ 12]) is not exceeded.
- Where applicable, also take into account external energy sources (such as radiated heat sources) that could additionally heat the medium.
- In case of doubt, contact KNF Customer Service.

2.6 Use

2.6.1 Proper use

The pumps are intended exclusively for transferring gases and vapors.

The pumps are intended exclusively for operation in indoor areas and in non-explosive atmospheres.

2.6.2 Foreseeable misuse

The pumps must not be operated in explosive atmospheres.

The pumps are not suitable for transferring the following:

- Dusts
- Liquids
- Aerosols
- Biological and microbiological substances

- Fuels
- Explosives and flammable materials
- Fibers
- Oxidizing agents
- Foodstuffs.

As standard, the pumps must not be used for simultaneous generation of a vacuum and positive pressure.

This function can be made possible on a project basis following consultation with KNF Customer Service.

Do not apply positive pressure to the inlet of the pump.

This function can be made possible on a project basis following consultation with KNF Customer Service.

2.7 Directives and standards

EU/EC
Directives

Installation declaration – for partly completed machinery

With respect to the Machinery Directive 2006/42/EC, the pumps are partly completed machinery and are, therefore, to be regarded as not ready for use. Partly completed machinery may not be commissioned until it has been determined that the machine into which the partly completed machinery is to be installed complies with the provisions of the Machinery Directive 2006/42/EC. The following fundamental requirements of Annex I of Directive 2006/42/EC (general principles) are applied and observed:

- General principles no. 1
- No. 1.1.2. / 1.1.3. / 1.3.1. / 1.3.3. / 1.3.4. / 1.4.1. / 1.5.8. / 1.5.9. / 1.7.4. / 1.7.4.1. / 1.7.4.3.

Standards

The following standards apply:

- EN 61000-6-2/3
- EN IEC 63000

The protective goals of the following directive(s) are achieved:

- Directive 2011/65/EU on the restriction of the use of certain hazardous substances in electrical and electronic equipment (Annex II changed by delegated Directive (EU) 2015/863 of the Commission)

2.8 Customer service and repair

Customer service and repairs The pump is maintenance-free. However, KNF recommends periodic inspection of the pump for obvious changes in noise or vibration.

Only have repairs to the pumps performed by qualified KNF personnel.

Housings with electrically live components may only be opened by specialist personnel.

Use only genuine spare parts from KNF when performing servicing work.

2.9 Disposal

Environmental protection Store the pump and all accessories in accordance with the environmental provisions. Observe national and international regulations. This applies in particular to parts that are contaminated with toxic substances.

If you no longer need your packaging materials (e.g. for return shipment or other transport of the device), dispose of them in an environmentally friendly manner.

Old devices must not be disposed of with household waste. Proper disposal and recycling helps to protect natural resources and the environment. The end user is responsible for disposing of old devices according to national and international regulations. Alternatively, KNF products (old devices) may also be returned to KNF for a fee (see chapter 11 *Returns* [▶ 55]).

3 Technical data

3.1 Technical data

Pump wetted materials

Assembly	Material
Pump head	Aluminum
Valves	EPDM
Diaphragm	PTFE-coated
Pneumatic head connection	
-Hose	PVC
-Fitting	Anodized aluminum

Tab.5: Pump wetted materials

Pneumatic values

Parameter	Value N813.3	Value N813.4
Max. permissible operating pressure [bar rel.]*	1.0	1.0
Ultimate vacuum at rated speed [mbar abs.]	3.0	0.5
Flow rate at atm. pressure and rated speed [l/min]**	13	13
Flow rate at atm. pressure and 0.1V control voltage (.29 version only) [l/min]**	4.2	3.5

Tab.6: Pneumatic values (N813_DC-B)

*bar rel relative to 1013 hPa

**Liters in the standard state (based on ISO 8778 and ISO 21360-1/2) (1013 hPa, 20°C)

Pneumatic connections

Parameter	Value
Inlet	Thread size G1/8
Outlet	Thread size G1/8

Tab.7: Pneumatic connections

Electrical performance

Parameter	Value	
Voltage [V]*	24	
Control voltage (.29 version only) [V]	0.1...5**	
Max. rated current draw [A]:	N813.3_DC-B	N813.4DC-B
- for $p > p_{atm.}$	1.44	2.7
- for $p < p_{atm.}$	0.96	1.6
Start-up current	The start-up current can be up to 50% higher than the max. rated current draw.	
Start-up ramp [ms]	800	
Max. power consumption of the pump [W]:	N813.3_DC-B	N813.4DC-B
- for $p > p_{atm.}$	34.56	64.8
- for $p < p_{atm.}$	23.0	38.4
Max. permissible supply voltage fluctuations	$\pm 10\%$	
Motor protection class (DIN EN 60529 / IEC 60529)	IP20	
Overcurrent limit of motor electronics [A]	7.5	

Tab.8: Electrical performance

*Further voltage variants on request



Protection against overheating

The pump is protected against overheating by a temperature sensor on the motor control board and is equipped with overcurrent protection. If one of these safety functions is triggered or if the maximum stall time of the rotor is exceeded in the event of a fault, the pump is switched off and must be reset manually:

- Disconnect the pump from electrical mains.
- Before switching back on, eliminate the fault cause(s).

Weight

Pump type	Weight [kg]
N813.3_DC-B	Approx. 2.3
N813.4_DC-B	Approx. 3.8

Tab.9: Weight

Other parameters

Parameter	Value
Permissible ambient temperature [°C]	+ 5 to + 40
Permissible media temperature [°C]	+ 5 to + 40
Dimensions N813.3_DC-B	See Fig. 4, Chapter 6.1 <i>Installing the pump</i> [▶ 20]
Dimensions N813.4_DC-B	See Fig. 5, Chapter 6.1 <i>Installing the pump</i> [▶ 20]
Highest permissible relative air humidity of the environment	80% for temperatures up to 31°C, decreasing linearly to 50% at 40°C.
Maximum installation altitude [m above sea level]	2000

Tab.10: Other parameters

4 Product description

Design

- 1 Pneumatic pump inlet
- 2 Pneumatic pump outlet
- 3 Pneumatic head connection
- 4 Motor

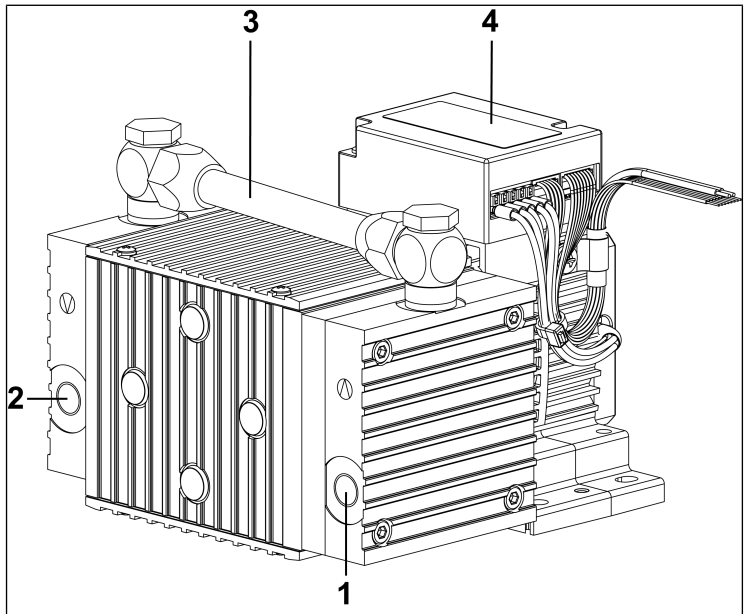

Fig.1: Design N813.3_DC-B

- 1 Pneumatic pump inlet
- 2 Pneumatic pump outlet
- 3 Pneumatic head connection
- 4 Motor

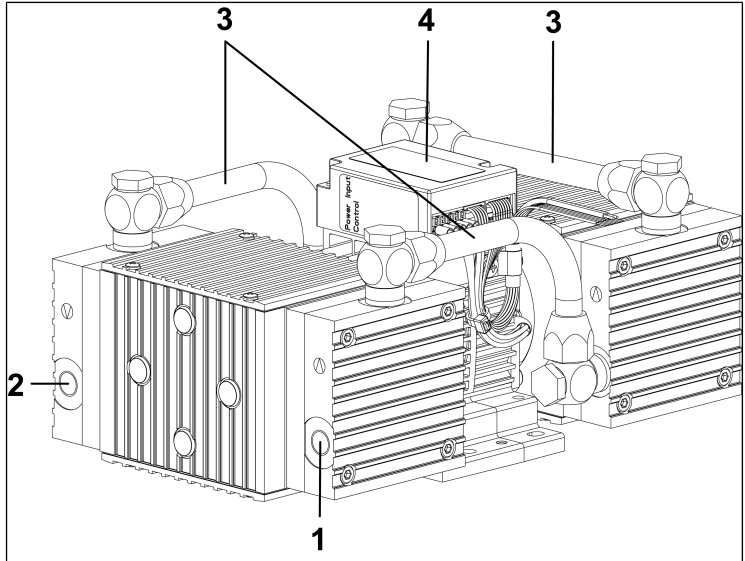

Fig.2: Design N813.4_DC-B

Function of a diaphragm pump

- 1 Outlet valve
- 2 Inlet valve
- 3 Transfer chamber
- 4 Diaphragm
- 5 Eccentric
- 6 Connecting rod

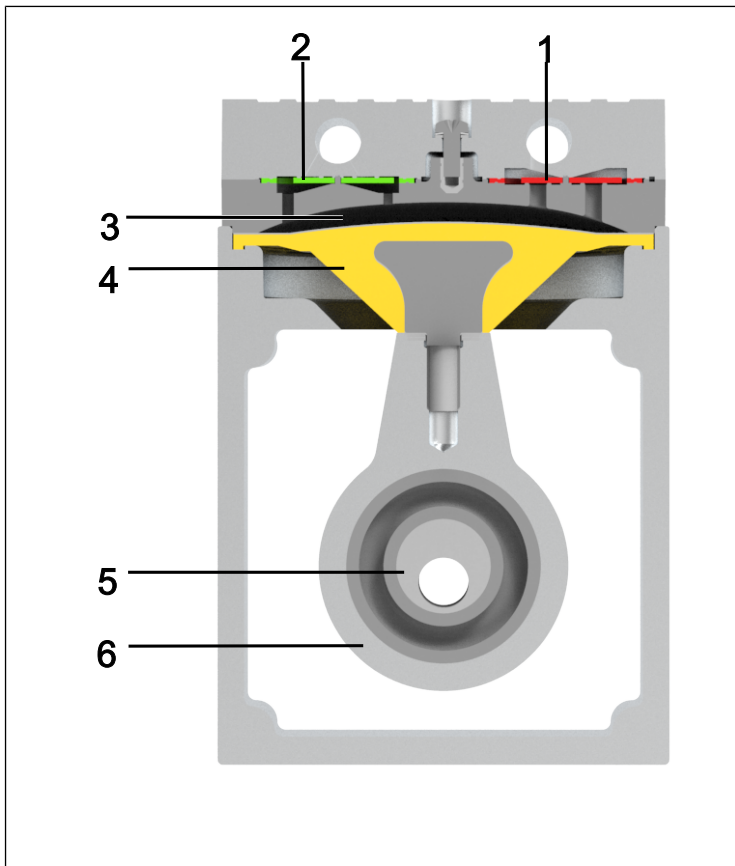

Fig.3: Function of a diaphragm pump

Diaphragm pumps transfer, compress (depending on the version) and evacuate gases and vapors.

The elastic diaphragm (4) is moved up and down by the eccentric (5) and the connecting rod (6). In the downwards stroke, it aspirates the gas to be transferred via the inlet valve (2). In the upwards stroke, the diaphragm presses the medium out of the pump head via the outlet valve (1). The transfer chamber (3) is separated from the pump drive by the diaphragm.

5 Transport

General



CAUTION

Personal injury and/or property damage due to incorrect or improper transport of the pump

In the event of incorrect or improper transport, the pump can fall down, be damaged or injure persons.

- Use suitable auxiliary means if necessary (carrying strap, lifting gear, etc.).
 - Where appropriate, wear suitable personal protective equipment (e.g., safety shoes, safety gloves).
-



CAUTION

Risk of injury from sharp edges on the packaging

There is a risk of injury from cutting on the sharp edges when grabbing corners or when opening the packaging.

- Where appropriate, wear suitable personal protective equipment (e.g., safety shoes, safety gloves).
-



Personal injury and/or property damage due to incorrect or improper transport of the pump

If the pump is raised and/or carried on the connection during transport, leaks and/or damages to the pump may result.

→ Do not carry the pump on the pneumatic connection.

- Transport the pump in the original packaging to the installation location.
- Keep the original packaging of the pump (e.g. for later storage).
- Inspect the pump for transport damage after receiving it.
- Document any transport damage that has occurred.
- Remove any transport safeguards on the pump prior to commissioning.

Parameter

Parameter	Value
Storage temperature [°C]	+ 5 to + 40
Transport temperature [°C]	- 10 to + 60
Permissible humidity (non-condensing) [%]	30 to 85

Tab. 11: Transport parameters and storage parameters



Prior to commissioning, make sure that the pump has reached the ambient temperature (3 Technical data [▶ 12]).

6 Installation and connection

Only install the pumps in accordance with the operating parameters and conditions described in Chapter 3 *Technical data* [▶ 12].

- Observe the safety instructions (see Chapter 2 *Safety* [▶ 6]).



DANGER

Risk of dangerous gas mixtures during pump operation

Depending on the medium being transferred, breakage of the media-contacting components can result in a dangerous mixture if the medium mixes with the air in the compressor housing or the surroundings.

- Before using a medium, check the compatibility of the media-contacting components (see 3 *Technical data* [▶ 12]) with the medium.

6.1 Installing the pump

- Store the pump at the installation site to allow it to adapt to the ambient temperature before installation (condensation must not be allowed to form).

Mounting dimensions

- For mounting dimensions, see the following illustrations:

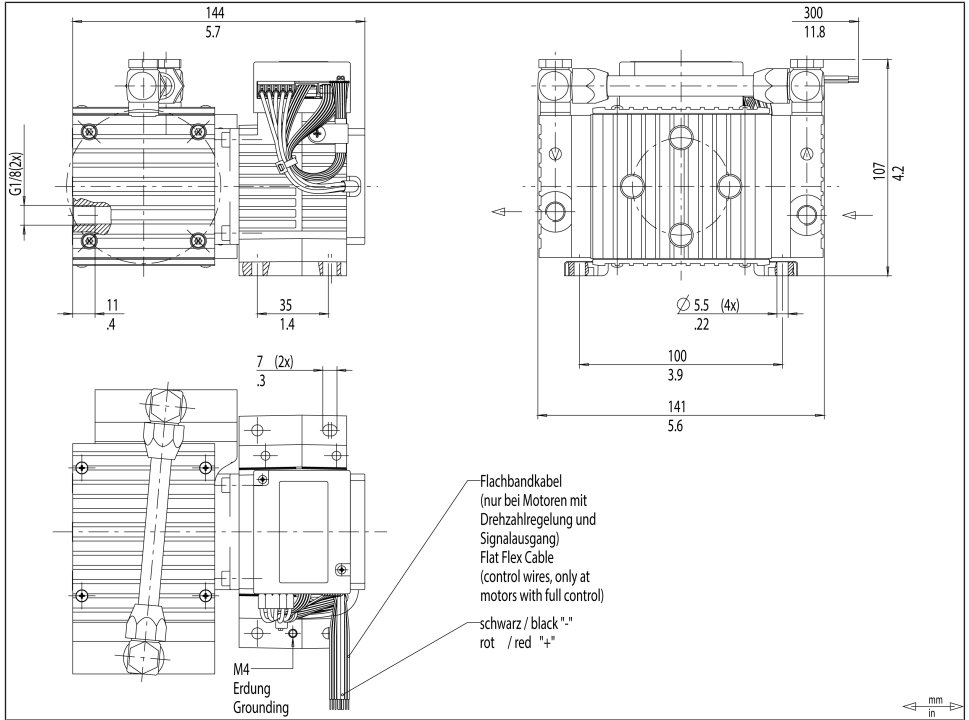

Fig. 4: Mounting dimensions N813.3_DC-B

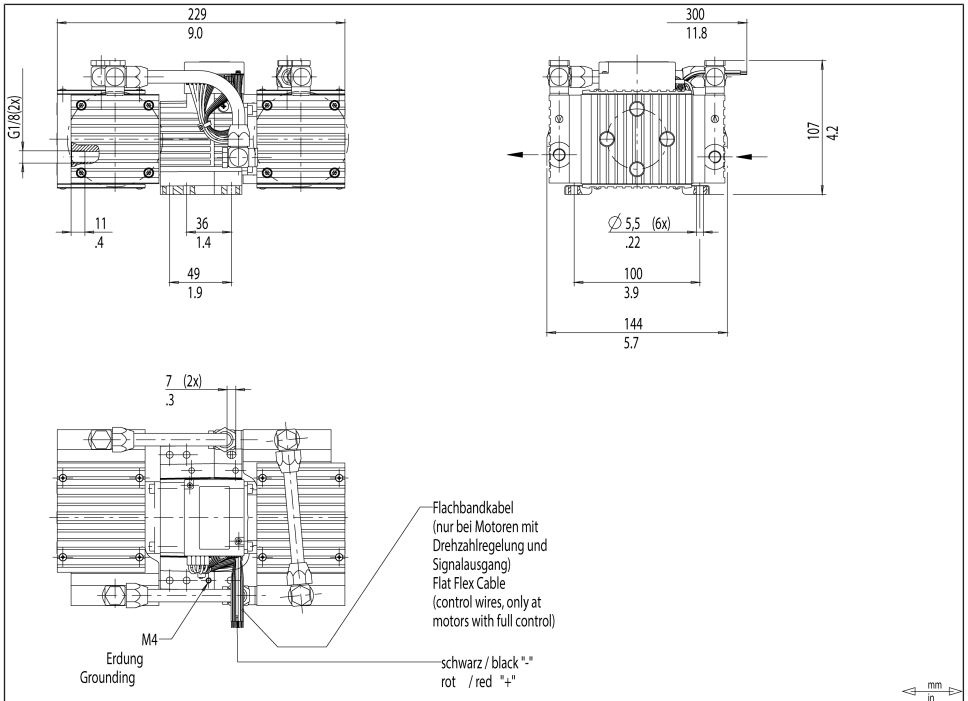

Fig. 5: Mounting dimensions N813.4_DC-B

Cooling air supply



WARNING

Danger of burning on hot surfaces

Hot surfaces could occur if the pump overheats.

→ When installing the pump, make sure that sufficient cooling air in-feed and discharge is ensured.

Proximity to hot pump parts

→ During installation, make sure that no combustible or thermally deformable objects are positioned in proximity to hot pump parts (head, motor).

Installation location

→ Make sure that the installation location is dry and that the pump is protected from rain, spray water, splash water, dripping water and other contaminants.

- Make sure the installation location allows access for servicing.
- i** The IP protection class of the pump motor is specified on the type plate.
- Install the pump at the highest point in the system to prevent condensate from collecting in the pump head.
- Protect the pump from dust.
- Protect the pump from vibration and impact.
- Installation position → The pump can be operated in any installation position. Use metal screws to fasten the pump at the indicated attachment points. Observe the specifications of the selected fasteners.
- i** Use rubber feet (accessories) to reduce vibration and noise. However, overhead or side mounting is then no longer permitted.

6.2 Electrical connection



DANGER

Danger to life from electric shock

- Only have the pump connected by an authorized specialist.
- Only have the pump connected if the power supply is disconnected.

-
- When connecting to a power source, observe the applicable standards, regulations, directives, and technical standards.
- Install a device for separating the pump motor from the electrical grid in the electrical installation (e.g. in accordance with EN 60335-1).
- i** Refer to the type plate for the maximum current consumption of the pump.

Fastening the
connection ca-
bles

- Install an Emergency Off device such that it is not possible for there to be an automatic restart or for hazardous situations to persons and property to occur.
- Install the pumps in such a way that it is not possible to touch electrically live parts (electrical connection).
- Fasten the connection cables so that
 - the cables do not come into contact with movable or hot parts.
 - the cables cannot be worn or damaged on sharp corners or edges
 - no tensile and pressure forces are exerted on the connection point of the cables (strain relief)

Connecting the pump

1. Confirm that the power supply meets the parameters listed on the pump type plate. Refer to the pump type plate for the rated current draw.
 - i** The supply voltage may deviate by maximum +10% or – 10% from the values on the type plate.
2. Connect the pump electrically (see *Tab. 12* [▶ 25] or *Tab. 13* [▶ 26]).



NOTICE

Ensure the correct polarity. With brushless DC motors (indicated by a B at the end of the type designation), incorrect polarity will result in damage to the electronics.



NOTICE

Control voltage may only be applied if the drive controller is supplied with an operating voltage. The drive controller may otherwise be damaged.



Ensure the correct polarity (see designation on motor). With brushless DC motors (indicated by a B at the end of the type designation), incorrect polarity will result in damage to the electronics. The supply leads have reverse polarity protection on the motor board while the control voltage leads do not have this protection function.

Connection diagram for motor controller

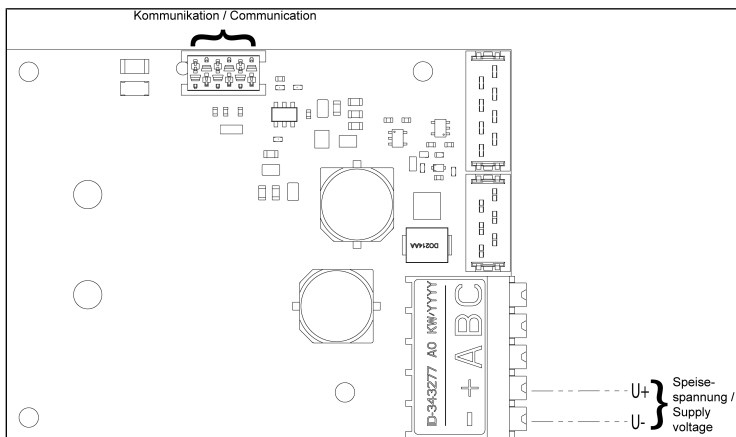

Fig. 6: Connection diagram for drive controller

Motor			
Rated voltage		[V]	12 / 24
Electrical connections			
Leads connections			
Function	Wire lead color	Signal name	Size
+ Supply voltage	Red	U ₊	AWG 18
- Supply voltage (0 V)	Black	U ₋ / GND	AWG 18

Tab.12: Connection diagram for drive controller

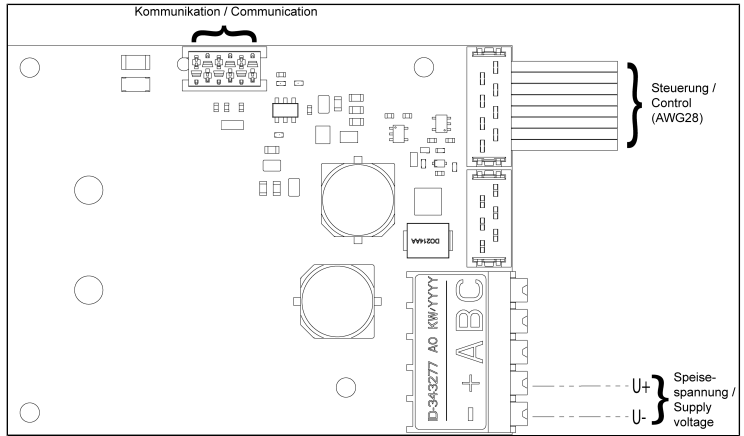

Fig.7: Connection diagram for drive controller

Motor				
Rated voltage		[V]	12 / 24	
Electrical connections				
Leads connections				
Function	Wire lead color	Signal name	Size	
+ Supply voltage	Red	U ₊	AWG 18	
- Supply voltage (0 V)	Black	U ₋ / GND	AWG 18	
5V output voltage	Black	U _{5V}	AWG 28 UL 20932	
Input signal for speed control	White	U _{Ctrl}	AWG 28 UL 20932	
Output signal for speed	Yellow	U _{Spd}	AWG 28 UL 20932	
Input signal for remote ON/OFF	Green	U _{Rmt}	AWG 28 UL 20932	
Output signal for error	Purple	U _{Flt}	AWG 28 UL 20932	
Ground	Gray & blue & orange	GND	AWG 28 UL 20932	
5V output voltage U_{5V}				
DC output voltage		[V]	5 ± 0.2	
Max. output current		[mA]	170	
Input signal for speed control U_{Ctrl}				
Analog	DC control voltage range		[V]	0...5
	Control voltage description: min. → Min. pump flow rate max. → Max. pump flow rate		[V]	Min. 0.1 Max. 5
PWM signal	PWM frequency range		[Hz]	100 [50 ... 150]
	Duty cycle range		[%]	0 ... 100

Motor			
	Duty cycle description: min. → Min. pump flow rate max. → Max. pump flow rate	[%]	Min. Max. 2 100
Output signal for speed U_{Spd}			
Analog	Pulses per revolution	[-]	1
	Pulse duty cycle	[%]	50 ± 1
PWM signal	PWM frequency	[Hz]	50 ± 0.5

Tab.13: Connection diagram for drive controller

6.3 Pneumatic connection



Personal injury or property damage through ejected plugs

If not removed, the plugs on the outlet of the pump can be ejected during operation by the resulting overpressure.

- Remove the plugs during installation.
- Wear appropriate personal protective equipment.

-
- Connected components → Only connect components to the pump that are designed for the pneumatic data and thermal requirements of the pump. (see Chapter 3 *Technical data* [▶ 12]).
 - Pump discharge → Discharge the possibly hot pump discharge at the pneumatic outlet of the pump safely (with regard to medium and noise).
 - Decoupling → KNF recommends mechanically decoupling the pump from the pipe system, e.g., through the use of flexible hoses or pipes. In this way it is possible to prevent the transfer of possible pump vibrations and noises to the system.

Connecting the pump

i A marking on the pump head indicates the flow direction.



CAUTION

Risk of injury due to mixing up inlet and outlet

Mixing up the inlet and outlet may cause breakage of components connected at the inlet and outlet.

→ Observe the marking of inlet and outlet on the pump head.

-
1. Remove the protective plugs from the hose connection threads.
 2. Screw accessories such as silencers or hose connectors (if present) onto the corresponding hose connection threads.
 3. Connect the suction line and the pressure line (for mounting dimensions, see Chapter 3 *Technical data* [p. 12]).
 4. Lay the suction line and pressure line with a descent so that no condensate can run into the pump.

i Pneumatic noises can be reduced or dissipated by using a silencer.

7 Operation

7.1 General



WARNING

Risk of burns from hot pump parts and/or hot medium

Some pump parts may be hot during or after operation of the pump.

- Allow the pump to cool after operation.
 - Take protective measures to protect against touching hot parts.
-



WARNING

Injury to eyes

Coming too close to the inlet/outlet of the pump may result in injury to the eyes due to the present vacuum/operating pressure.

- Do not look into the pump inlet/outlet during operation.
-

- Only operate the pumps under the operating parameters and operating conditions as described in Chapter 3 *Technical data* [▶ 12].
- Ensure the proper use of the pumps (See Chapter 2.6.1 *Proper use* [▶ 9]).
- Rule out the possibility of foreseeable misuse of the pumps (see chapter 2.6.2 *Foreseeable misuse* [▶ 9]).
- Observe the safety instructions (Chapter 2 *Safety* [▶ 6]).
- The pumps are built-in devices. Before they are commissioned, it must be ensured that the machines or systems into which the pumps are installed comply with the relevant provisions.



Risk of bursting of pump head due to excessive pressure increase

- Do not exceed the maximum permissible operating pressure (see 3 *Technical data* [p. 12]).
- Monitor the pressure during operation.
- If the pressure exceeds the maximum permissible operating pressure of the pump: Switch the pump off immediately and remedy the malfunction (see Chapter 10 *Störung beheben* [p. 50]).
- Only throttle or regulate the air or gas quantity on the inlet line to prevent the maximum permissible operating pressure from being exceeded.
- If the air quantity or gas quantity on the outlet line is throttled or regulated, make sure that the maximum permissible operating pressure at the pump is not exceeded.
- Ensure that the pump outlet is not closed or restricted.



Excessive pressure, with all of the associated hazards, can be prevented by means of a bypass line with a pressure relief valve between the outlet and inlet of the pump. Further information is available from KNF Customer Service (contact data: see www.knf.com).



Risk of dangerous gas mixtures during pump operation if diaphragm breaks

If the diaphragm should break, the medium will mix with the air in the compressor housing or in the surroundings.

→ Stop pump immediately.

→ Replace the diaphragm prior to further operation (see Chapter 8 *Servicing* [▶ 40]).



Operation with open gas connection at the inlet can result in contaminants and objects being drawn in.

Pump standstill → When the pump is at a standstill, establish normal atmospheric pressure in the lines.

Vapors as medium The service life of the diaphragm can be extended, if no condensate forms in the pump. Therefore:

→ Perform any work with saturated or near-saturated vapors only with a warm pump.

→ KNF recommends: When pumping corrosive media, flush the pump before switching off (see Chapter 8.2.1 *Flushing the pump* [▶ 41]) to extend the service life of the diaphragm.

7.2 Information on switching the pump on and off

Switching on the pump

i The pump may start up against pressure and/or vacuum during switch-on (see 3 *Technical data* [▶ 12]). This also applies during operation after a brief power failure.

→ Ensure that normal atmospheric pressure is present in the lines when switching on.

Switching off/decommissioning the pump

→ Establish normal atmospheric pressure in the lines (relieve pump pneumatically).

Recommissioning

→ Before recommissioning, observe the applicable standards, guidelines, regulations and technical standards at the electrical connection.

Inspecting the pump

→ Inspect the pump periodically for external damage or leakage.

7.3 DC-B control functions

7.3.1 Speed control

DC-B (constant speed)

The motor operates the pump at a constant, non-variable speed over the entire permissible pressure range.

.29DC-B (adjustable speed)

The motor operates the pump at a variable speed between n_{\min} and n_{\max} . The speed is specified by means of the control voltage.

7.3.2 Speed input [.29 version]

Speed range The speed range from n_{\min} to n_{\max} is derived by scaling to the control voltage U_{Ctrl} :

→ $U_{\text{Ctrl min}}$: 0.1 V

→ $U_{\text{Ctrl max}}$: 5.0 V

If the control voltage is lower than $U_{Ctrl\ min}$, the motor is OFF.

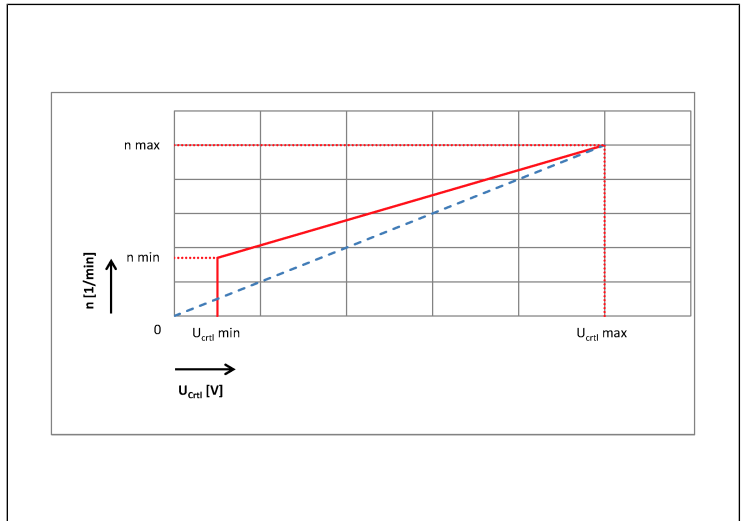

Fig. 8: Control voltage-speed characteristic (standard)

Speed specification The speed is specified via the 8-pin control connection (white lead).

Optional analog settings for control voltage input

If desired, the following additional settings can be made at the factory:

- Changing the control voltage values $U_{Ctrl\ min}$ and $U_{Ctrl\ max}$.
- If the control voltage is lower than $U_{Ctrl\ min}$, the motor is ON.

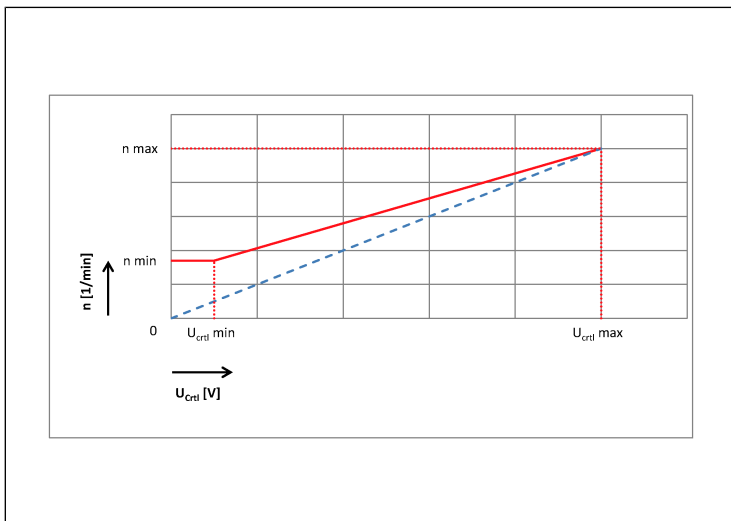

Fig.9: Control voltage-speed characteristic (optional)

7.3.3 Speed output [.29 version]

Speed output The speed output signal comes from the 8-pin control connection (yellow lead).

The drive controller generates a speed-synchronous pulse width modulation signal.

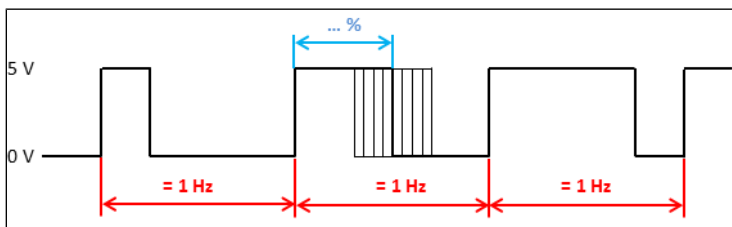

Fig.10: Analog speed output (standard)

Optional speed output

The drive controller generates a speed-synchronous square wave frequency with 5V TTL level.

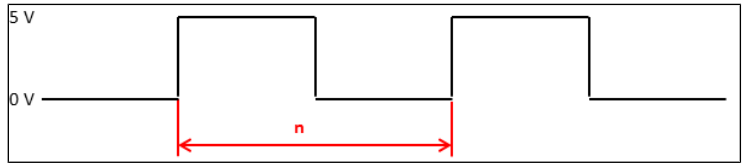

Fig. 11: Digital speed output (optional)

7.3.4 Remote ON/OFF [.29 version]

Remote ON/OFF The remote ON/OFF signal comes from the 8-pin control connection (green lead).

i To start the motor, the green lead must be connected to the ground of the control connection (gray, blue or orange leads).

7.3.5 External digital actuation [.29 version]

External actuation On request, the pump motor can be actuated externally. A special setting must be made ex works for this purpose (contact details: see www.knf.com).

External actuation takes place via the 6-pin communication connection.

Connector type: Micro-Match Female Top Entry

Art. no: 7-215079-6

i If the motor is actuated externally, the control inputs are inactive.

Connection of the communication connector

Pin 1 – Do not connect

Pin 2 – Do not connect

Pin 3 – GND

Pin 4 – 5V (max. 50 mA)

Pin 5 – TX MBLC

Pin 6 – RX MBLC

Connection options for motor – external control unit

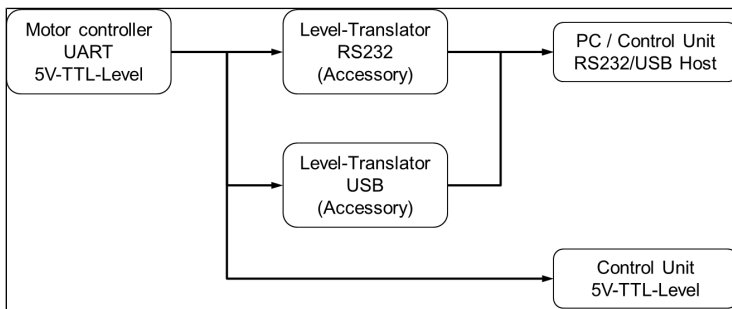

Fig. 12: External actuation options (optional)

The following motor functions can be controlled:

→ Motor remote ON/OFF

The factory setting for the motor when the operating voltage is applied is OFF. Optionally, the motor can also be ON when the operating voltage is applied.

→ Motor speed

Setting the motor speed within the speed limits n_{\min} and n_{\max} .

→ Readout of the following process parameters:

- Actual/target motor speed
- Motor speed control limits
- Motor current consumption
- Drive controller temperature
- Error status
- Software version number

Interface protocol The connection between PC and drive controller can be operated as an RS232 interface. It is managed accordingly in the operating system as an additional COM connection and can be addressed with conventional terminal software.

Interface configuration

- Baud rate: 57600 bits/s
- Data bits: 8
- Parity: none

- Stop bits: 1
- Flow control: none

The following tables contain the command sets necessary for the interface protocol, expressed as Ascii characters. Each of the commands is to be terminated with the ASCII character <CR> (carriage return, decimal value 013). The underlined expressions are not characters but rather symbols. They are explained in the "Symbols" table.

Parameter	Command*	Function	Answer
Motor	dB	Start	<u>S</u> ; <u>E</u>
	dE	Stop	<u>S</u> ; <u>E</u>
Speed	dSnnnn [nnnn = speed value]	Set target speed	<u>ns</u> ; <u>E</u>

Tab. 14: Control commands

*After command set "dB", a pause of min. 25 ms must be observed.

Parameter	Command	Answer
Actual motor speed; Motor current consumption; Drive controller temperature; Error status	pP	<u>ni</u> ; <u>ii</u> , <u>ti</u> , <u>ei</u> , <u>E</u>
Error status (single value)	gP	<u>ei</u> ; <u>E</u>
Target motor speed	gS	<u>ns</u> ; <u>E</u>
Minimum possible Motor speed	gSl	<u>nl</u> ; <u>E</u>
Maximum possible Motor speed	gSh	<u>nh</u> ; <u>E</u>
Software version number	iV	<u>V</u> ; <u>E</u>

Tab. 15: Read commands

Symbol	Function	Meaning
E	Success message	0 Command cannot be executed
		1 Command executed
		? Command not clear
S	Status message	For service only
V	Version number	e.g., 01.018
ni	Actual motor speed	Numerical value [rpm]
ns	Target motor speed	Numerical value [rpm]
nl	Minimum Target motor speed	Numerical value [rpm]
nh	Maximum Target motor speed	Numerical value [rpm]
ii	Motor current consumption	Numerical value [mA]
ti	Temperature of drive controller	Numerical value [°C]
ei	Error status	16-bit numerical value

Tab. 16: Symbols

The symbols represent the ASCII code of numerical sequences of any length. Input values are only processed by the controller as whole numbers (integers).

Interface level

i The pin assignment of the communication connector of the drive controller can be found in chapter 7.3.5 *External digital actuation [.29 version]* [▶ 36].

Parameter	Value
Rx KNF MBLC	Low: 0V...0.9V High: 4.2V...5.2V
Tx KNF MBLC	Low: 0V...0.6V High: 4.5V...5.2V

8 Servicing



NOTICE

Servicing the pump

Damage to the pumps can result from failure to observe the applicable legal regulations and procedures for the location or intervention by untrained or uninstructed personnel.

- Servicing may only be performed according to the legal regulations (e.g. work safety, environmental protection) and provisions.
 - Servicing may only be performed by specialized personnel or trained and instructed personnel.
-

8.1 Servicing schedule

Component	Servicing interval
Pump	<ul style="list-style-type: none"> → Perform periodic inspections for external damage or leakage. → Periodically check for noticeable changes to noises and vibrations.
Gas connections	<ul style="list-style-type: none"> → Perform periodic inspections for external damage or leakage.
Diaphragms and valves	<ul style="list-style-type: none"> → Replace if the pressure or flow rate of the pump changes for no apparent reason. → At the latest, replace when the performance decreases.
Silencer (accessories)	<ul style="list-style-type: none"> → Replace if soiled.

Tab.17:

8.2 Cleaning

8.2.1 Flushing the pump

When transferring dangerous and environmentally hazardous media, KNF recommends flushing the pump with air at atmospheric pressure for a few minutes prior to switch-off (if necessary for safety reasons: with an inert gas) to extend the service life of the diaphragm.

→ Discharge the media safely.

8.2.2 Cleaning the pump

Requirements → Pump disconnected from mains and voltage-free

**CAUTION**

Risk of burns from hot pump parts

The pump head or motor may still be hot after operation of the pump.

- Allow the pump to cool after operation.

**WARNING**

Health hazard due to dangerous substances in the pump

Depending on the medium being transferred, caustic burns or poisoning is possible.

- Wear protective equipment if necessary, e.g., protective gloves, goggles.
- Clean the pump with suitable measures.

**NOTICE**

During cleaning work, ensure that no fluids enter the interior of the housing.

- Only clean the pump with a dry wiping cloth. When cleaning, use no solvents if possible as these can affect the plastic parts.
- Only use solvents during cleaning if head materials are not corroded (ensure resistance of the material).
- If compressed air is available, blow out the components.

8.3 Replacing diaphragm and valves

- Requirements → Disconnect the drive from the mains and ensure that it is deenergized.

- Allow the pump and the drive to cool.
- Clean the pump and free the pump of hazardous materials.
- Remove the hoses/pipes from the pneumatic pump inlet and outlet.

**CAUTION**

Risk of burns from hot pump parts

The pump head or motor may still be hot after operation of the pump.

- Allow the pump to cool after operation.

**WARNING**

Health hazard due to dangerous substances in the pump

Depending on the medium being transferred, caustic burns or poisoning is possible.

- Wear protective equipment if necessary, e.g., protective gloves, goggles.
- Clean the pump with suitable measures.

Information on the procedure

The diaphragm, valves and sealing rings are the only wearing parts in the pumps.

- Always replace the diaphragm and valves together so as to maintain the performance and safety of the pump.

Spare parts

Parts	Item number*	Quantity per head
Valves	(6)	2
Sealing ring	(7)	2
Diaphragm	(8)	1

Tab. 18: Spare parts

Tools and material

Quantity	Tool/material
1	Box wrench 14mm (alternatively: Open-end wrench 14 mm)
1	Size 1 Phillips screwdriver
1	Felt-tip pen
1	For N813.4_ Open-end wrench 17 mm

Tab.19: Tools and material

- 1 Housing
- 2 Intermediate plate
- 3 Head plate
- 4 Hexagon socket screw
- 5 Cover
- 6 Valve
- 7 Sealing ring
- 8 Diaphragm
- 9 Shim(s)
- 10 Connecting rod
- 11 Counter-weight

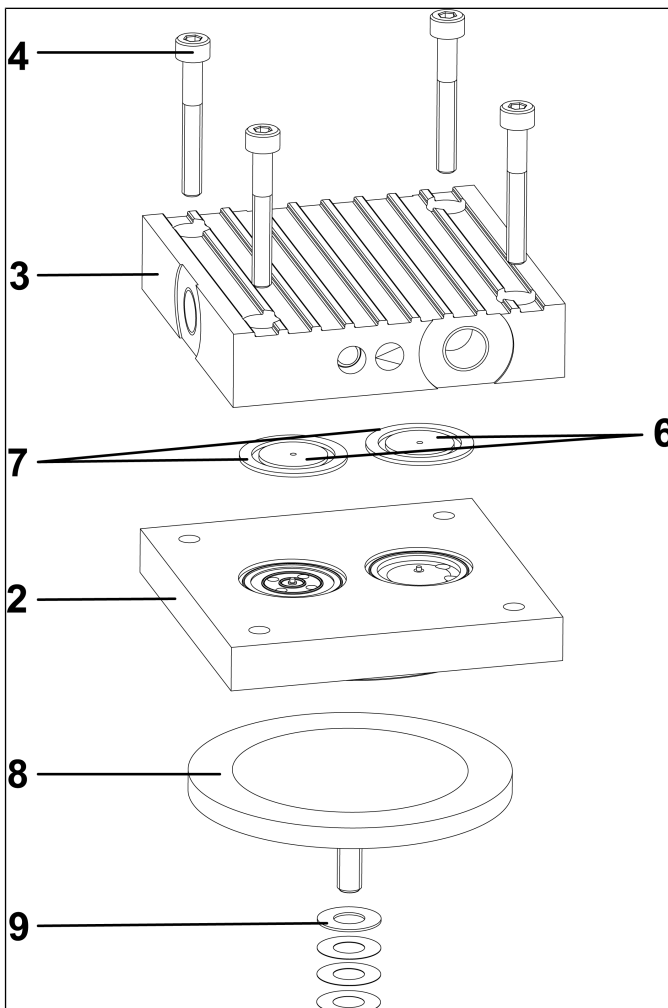

Fig.13: Pump head (exploded view, symbolic)

- 12** Pneumatic connection .3
- 14** Pneumatic connection .4

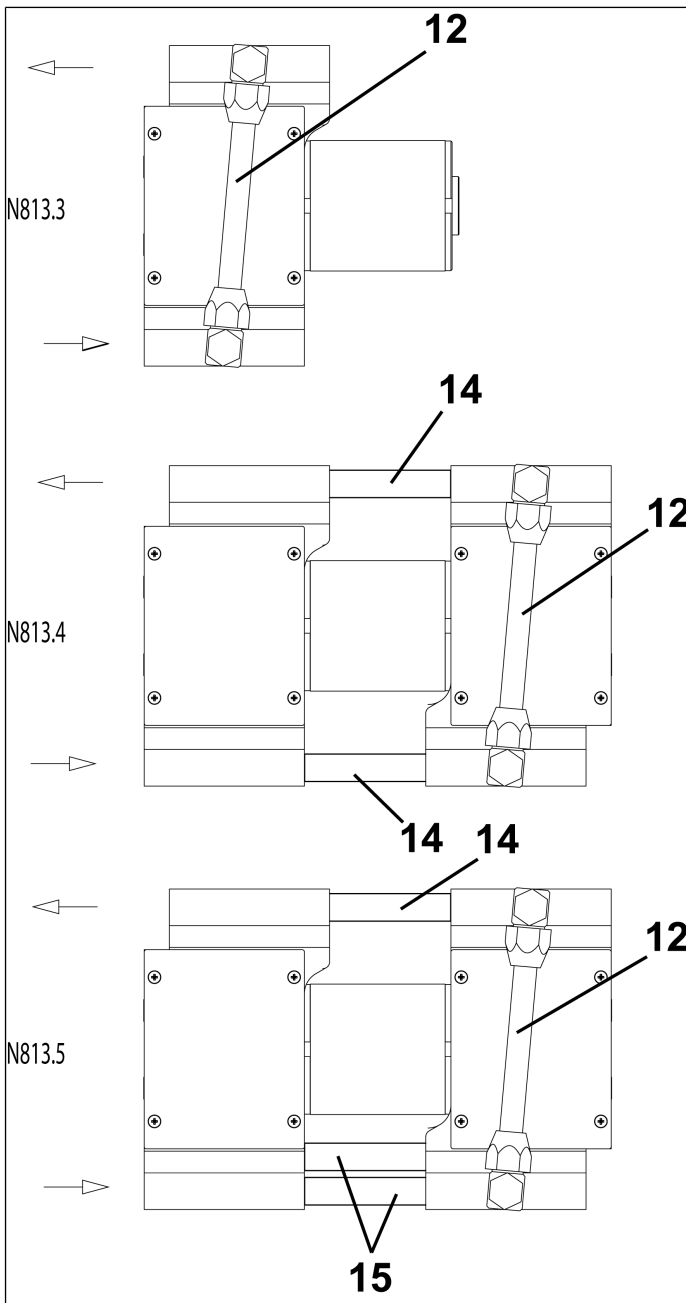

Fig.14: Pneumatic connections (diagrammatic figure)

Perform diaphragm, valve and sealing ring replacement in the following order:

- a) Removing the pneumatic head connection(s)
- b) Removing the cover from the housing
- c) Removing the pump head
- d) Changing the diaphragm
- e) Changing the valve plates and sealing rings
- f) Mounting the pump head
- g) Mounting the cover on the housing
- h) Assembling the pneumatic head connection(s)

With the exception of removing and reassembling the cover(s) and the pneumatic head connection(s), all work must be performed separately for each head to prevent parts mix-ups (head plates of the heads are not identical).

The item numbers within the following work instructions refer to *Replacing diaphragm and valves* [▶ 44] to Fig. 14.

a) Removing pneumatic head connections (once for all pump heads)

N813.3_:

1. Remove the pneumatic head connection (**12**).
Open the fitting (**13**) on both pump heads with the 14 mm wrench and lift off the connection upwards.

N813.4_:

2. Remove the pneumatic head connection (**12**).
Open the fitting (**13**) on both pump heads with the 14 mm wrench and lift off the connection upwards.
3. Open the two pneumatic head connections (**14**) with the 17 mm open-end wrench and remove them.

b) Removing the cover

1. Remove the cover(s) (**5**) from the housing (**1**) after loosening the four screws.

c) Removing the pump head (for each head separately)

1. Mark the head plate (**3**), intermediate plate (**2**) and housing (**1**) with a continuous felt-tip pen line (**M**). This helps to avoid incorrect assembly later.

2. Loosen the four head plate screws (4) and remove the head plate together with the intermediate plate from the pump housing.

d) Diaphragm replacement

1. Move the counterweight (11) to move the diaphragm (8) to the upper reversal point.
2. Lift the diaphragm by the opposite side edges, grasp the diaphragm and unscrew it counterclockwise.
3. Remove the shim(s) (9) from the threaded bolt of the diaphragm and slide the shim(s) (9) onto the threaded bolt of the new diaphragm (8).
4. Check all parts for contamination and clean them if necessary (see 8.2 *Cleaning* [▶ 41]).
5. Move the connecting rod (10) to the upper reversal point via the counterweight (11).
6. Screw the new diaphragm with shim(s) onto the connecting rod (clockwise) and tighten finger-tight.

e) Changing valves and sealing rings

1. Separate the head plate (3) from the intermediate plate (2).
2. Remove the valves (6) and sealing rings (7) from the intermediate plate.
3. Check the valve seats, intermediate plate and head plate for cleanliness; replace these parts in the event of unevenness, scratches or corrosion.
4. Insert the new valves into the valve seats of the intermediate plate.

i The valves and sealing rings for outlet and inlet are identical; the same applies for the top and bottom of the valves and sealing rings.

5. By slightly moving the valves horizontally, ensure that they are not under tension.
6. Insert the sealing rings into the intermediate plate.

f) Mounting the pump head

1. Move the diaphragm (8) to top dead center via the counterweight (11).

2. Place the intermediate plate **(2)** with valves **(6)** and sealing rings **(7)** and head plate **(3)** on the housing according to the markings **(M)**.
3. Only slightly tighten the screws **(4)** crosswise.
4. Check the smooth running of the pump by moving the counterweight.
5. Finger-tighten the screws **(4)**.
6. Perform tasks c), d), e) and f) for the further pump head(s).

g) Mounting the cover on the housing

1. Reattach the cover **(5)** to the housing **(1)**.

h) Fitting the connection

1. Reassemble the pneumatic head connection(s).

If you have questions with regard to maintenance, please contact your KNF technical adviser (telephone number: see last page).

9 Spare parts and accessories

i To order spare parts and accessories, please contact your KNF sales partner or KNF Customer Service (contact data: see www.knf.com).

9.1 Spare parts

Spare part set

A spare part set consists of:

Parts	Item number*	Quantity per head
Valves	(6)	2
Sealing ring	(7)	2
Diaphragm	(8)	1

Tab.20: *See Chapter 8.3 Replacing diaphragm and valves [► 42]

Spare part set	Order number
N813.3_	032494
N813.4_	343346

Tab.21: Spare part set

9.2 Accessories

Designation	Order number
Silencer G1/8	000346
Hose nipple G1/8	005148
Seal for G1/8	026906

Tab.22: Accessories

10 Troubleshooting



Danger: electric shock can be life-threatening.

- All work on the pump may only be performed by an authorized specialist.
- Before working on the pump: Disconnect the pump from the power supply.
- Check and ensure that no voltage is present.

-
- Allow the pump to cool before troubleshooting.
 - Check the pump (see following tables).

Pump not delivering	
Cause	Troubleshooting
Pump is not connected to the electrical mains.	→ Connect the pump to the electrical mains.
No voltage in the electrical mains.	→ Check the circuit breaker for the room and switch it on if necessary.
Pneumatic connections or lines are blocked.	→ Check the connections and lines. → Remove the blockage.
External valve is closed or filter clogged.	→ Check external valves and filters.
Condensation has collected in the pump head.	→ Separate the source of the condensation from the pump. → Flush the pump with air at atmospheric pressure for a few minutes (if necessary for safety reasons: with an inert gas). → Install the pump at the highest location in the system.
Overcurrent protection of the motor control board tripped Maximum temperature of the motor control board exceeded Maximum lock time of the rotor exceeded	→ Disconnect pump from mains. → Determine and rectify the cause of the overcurrent, overheating or blocking (e.g., inadmissible pressure conditions, liquid in the pump heads). i The pump must be disconnected from mains for several seconds before the electronics reset.
Incorrect polarity of the connection leads	→ Disconnect pump from electrical mains. → Ensure correct polarity of the connection leads and connect the pump.
Diaphragm and valves are worn or defective.	→ Replace diaphragm and valves (see Chapter 8 <i>Servicing</i> [▶ 40]).

Tab.23:

Flow rate, pressure or vacuum too low	
The pump does not reach the performance stated in the technical data or data sheet.	
Cause	Troubleshooting
Condensation has collected in the pump head.	<ul style="list-style-type: none"> → Separate the source of the condensation from the pump. → Flush the pump with air at atmospheric pressure for a few minutes (if necessary for safety reasons: with an inert gas). → Install the pump at the highest location in the system.
There is overpressure on the pressure side and at the same time vacuum or pressure above atmospheric pressure on the suction side.	<ul style="list-style-type: none"> → Change the pneumatic conditions.
Pneumatic lines or connection parts have insufficient cross-sections or are constricted.	<ul style="list-style-type: none"> → Disconnect the pump from the system to determine the output values. → Eliminate any constriction (e.g. valve). → Use lines or connection parts with a larger cross-section if necessary.
Leaks occur at pneumatic connections, lines or pump head.	<ul style="list-style-type: none"> → Eliminate the leaks.
Pneumatic connections or lines are partially or completely blocked.	<ul style="list-style-type: none"> → Check the pneumatic connections and lines. → Remove any parts or particles that are causing blockages.
Head parts are soiled.	<ul style="list-style-type: none"> → Clean the head components.
Working diaphragm broken	<ul style="list-style-type: none"> → Stop the pump immediately. → Change the diaphragm (see <i>8 Servicing</i> [▶ 40]).
Diaphragm and valves are worn or defective.	<ul style="list-style-type: none"> → Replace diaphragm and valves (see <i>Chapter 8 Servicing</i> [▶ 40]).
Replaced diaphragms and valve plates.	<ul style="list-style-type: none"> → Ensure that shim rings were fitted on the diaphragm thread.

Flow rate, pressure or vacuum too low	
The pump does not reach the performance stated in the technical data or data sheet.	
Cause	Troubleshooting
	→ Check the head connection and hose connections for leaks.

Tab.24:

Pump exhibiting changed running noises and vibrations	
Cause	Troubleshooting
Pump bearing worn or defective.	→ Determine the cause. → Contact KNF Customer Service.

Tab.25:

Display of the errors at the drive controller

Exceeding the overcurrent limit, exceeding the maximum temperature for the motor control board, or blockage of the rotor are displayed as errors. A red LED on the drive controller indicates the cause of the fault.

Optional setting:

If desired, the drive controller can be programmed so that the voltage of the fault output has the same characteristic as the LED.

The manufacturer only provides for logic 1 or 0 via a voltage at the fault output.

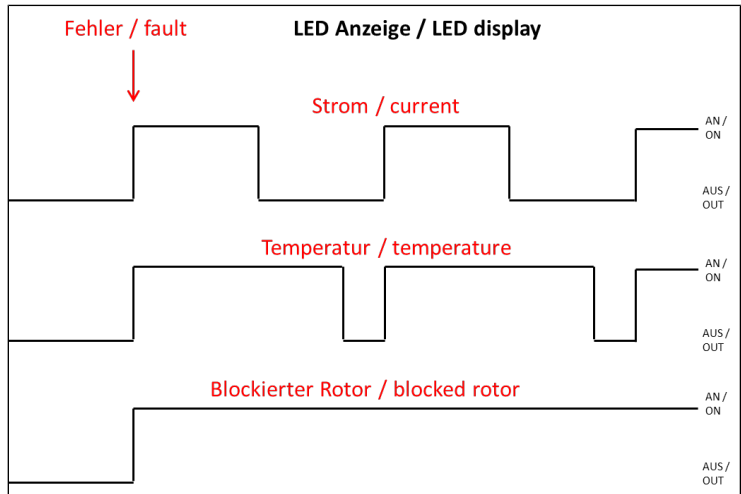

Fig. 15: LED flashing duration for various faults

To clear the fault, the motor must be disconnected from the supply voltage.

Fault cannot be rectified

If you are unable to identify any of the specified causes, send the pump to KNF Customer Service (contact data: see www.knf.com).

1. Flush the pump with air for a few minutes (if necessary for safety reasons: with inert gas) at atmospheric pressure to free the pump head of dangerous or aggressive gases (see Chapter 8.2.1 *Flushing the pump* [▶ 41]).
2. Clean the pump (see Chapter 8.2.2 *Cleaning the pump* [▶ 41]).
3. Send the pump together with completed Health and Safety Clearance and Decontamination Form to KNF, specifying the pumped medium.

11 Returns

Preparing for return

1. Flush the pump with air for a few minutes (if necessary for safety reasons: with inert gas) at atmospheric pressure to free the pump head of dangerous or aggressive gases (see Chapter 8.2.1 *Flushing the pump* [▶ 41]).
i Please contact your KNF sales partner if the pump cannot be flushed due to damage.
2. Remove the pump.
3. Clean the pump (see Chapter 8.2.2 *Cleaning the pump* [▶ 41]).
4. Send the pump together with the completed Health and Safety Clearance and Decontamination Form to KNF, stating the nature of the transferred medium.
5. Pack the device securely to prevent further damage to the product. If necessary, request original packaging for a fee.

Returns

KNF shall undertake to repair the pump only under the condition that the customer presents a certificate regarding the medium that is pumped and the cleaning of the pump. In this case too, old devices can be returned. Please follow the instructions at [knf.com/repairs here](http://knf.com/repairs).

Contact your KNF sales partner directly if you require additional support for your return service.

KNF Neuberger GmbH
Alter Weg 3
79112 Freiburg
Germany
Tel. +49 (0)7664/5909-0

E-mail: info.de@knf.com
www.knf.com

KNF worldwide

You can find our local KNF partners at: www.knf.com

