



## 8292 GPIB CONTROLLER

- Complete IEEE Standard 488 Controller Function
  - Interface Clear (IFC) Sending Capability Allows Seizure of Bus Control and/or Initialization of the Bus
  - Responds to Service Requests (SRQ)
  - Sends Remote Enable (REN), Allowing Instruments to Switch to Remote Control
- Complete Implementation of Transfer Control Protocol
  - Synchronous Control Seizure Prevents the Destruction of Any Data Transmission in Progress
  - Connects with the 8291 to Form a Complete IEEE Standard 488 Interface Talker/Listener/Controller

The 8292 GPIB Controller is a microprocessor-controlled chip designed to function with the 8291 GPIB Talker/Listener to implement the full IEEE Standard 488 controller function, including transfer control protocol. The 8292 is a pre-programmed Intel® 8041A.

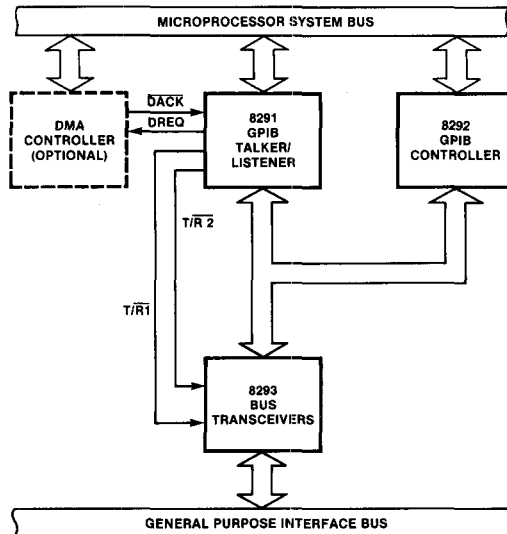

Figure 1. 8291, 8292 Block Diagram

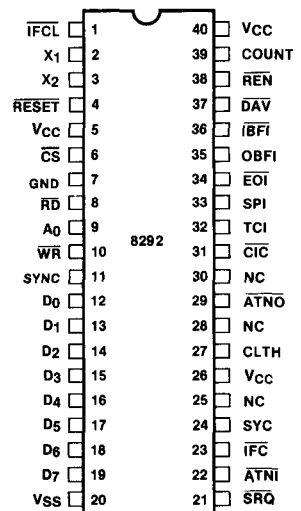

Figure 2. Pin Configuration

Table 1. Pin Description

Symbol	Pin No.	Type	Name and Function
IFCL	1	I	<b>IFC Received (Latched):</b> The 8292 monitors the IFC Line (when not system controller) through this pin.
X <sub>1</sub> , X <sub>2</sub>	2, 3	I	<b>Crystal Inputs:</b> Inputs for a crystal, LC or an external timing signal to determine the internal oscillator frequency.
RESET	4	I	<b>Reset:</b> Used to initialize the chip to a known state during power on.
CS	6	I	<b>Chip Select Input:</b> Used to select the 8292 from other devices on the common data bus.
RD	8	I	<b>Read Enable:</b> Allows the master CPU to read from the 8292.
A <sub>0</sub>	9	I	<b>Address Line:</b> Used to select between the data bus and the status register during read operations and to distinguish between data and commands written into the 8292 during write operations.
WR	10	I	<b>Write Enable:</b> Allows the master CPU to write to the 8292.
SYNC	11	O	<b>Sync:</b> 8041A instruction cycle synchronization signal; it is an output clock with a frequency of XTAL ÷ 15.
D <sub>0</sub> -D <sub>7</sub>	12-19	I/O	<b>Data:</b> 8 bidirectional lines used for communication between the central processor and the 8292's data bus buffers and status register.
V <sub>SS</sub>	7, 20	P.S.	<b>Ground:</b> Circuit ground potential.
SRQ	21	I	<b>Service Request:</b> One of the IEEE control lines. Sampled by the 8292 when it is controller in charge. If true, SPI interrupt to the master will be generated.
ATNI	22	I	<b>Attention In:</b> Used by the 8292 to monitor the GPIB ATN control line. It is used during the transfer control procedure.
IFC	23	I/O	<b>Interface Clear:</b> One of the GPIB management lines, as defined by IEEE Std. 488-1978, places all devices in a known quiescent state.
SYC	24	I	<b>System Controller:</b> Monitors the system controller switch.
CLTH	27	O	<b>Clear Latch:</b> Used to clear the IFC latch after being recognized by the 8292. Usually low (except after hardware Reset), it will be pulsed high when IFC is recognized by the 8292.
ATNO	29	O	<b>Attention Out:</b> Controls the ATN control line of the bus through external logic for tcs and tca procedures. (ATN is a GPIB control line, as defined by IEEE Std. 488-1978.)

Symbol	Pin No.	Type	Name and Function
V <sub>CC</sub>	5, 26, 40	P.S.	<b>Voltage:</b> +5V supply input ±10%.
COUNT	39	I	<b>Event Count:</b> When enabled by the proper command the internal counter will count external events through this pin. High to low transition will increment the internal counter by one. The pin is sampled once per three internal instruction cycles (7.5μsec sample period when using 5 MHz XTAL). It can be used for byte counting when connected to NDAC, or for block counting when connected to the EOL.
REN	38	O	<b>Remote Enable:</b> The Remote Enable bus signal selects remote or local control of the device on the bus. A GPIB bus management line, as defined by IEEE Std. 488-1978.
DAV	37	I/O	<b>Data Valid:</b> Used during parallel poll to force the 8291 to accept the parallel poll status bits. It is also used during the tcs procedure.
IBFI	36	O	<b>Input Buffer Not Full:</b> Used to interrupt the central processor while the input buffer of the 8292 is empty. This feature is enabled and disabled by the interrupt mask register.
OBFI	35	O	<b>Output Buffer Full:</b> Used as an interrupt to the central processor while the output buffer of the 8292 is full. The feature can be enabled and disabled by the interrupt mask register.
EO12	34	I/O	<b>End Or Identify:</b> One of the GPIB management lines, as defined by IEEE Std. 488-1978. Used with ATN as Identify Message during parallel poll.
SPI	33	O	<b>Special Interrupt:</b> Used as an interrupt on events not initiated by the central processor.
TCI	32	O	<b>Task Complete Interrupt:</b> Interrupt to the control processor used to indicate that the task requested was completed by the 8292 and the information requested is ready in the data bus buffer.
CIC	31	O	<b>Controller In Charge:</b> Controls the S/R input of the SRQ bus transceiver. It can also be used to indicate that the 8292 is in charge of the GPIB bus.

**FUNCTIONAL DESCRIPTION**

The 8292 is an Intel 8041A which has been programmed as a GPIB Controller interface element. It is used with the 8291 GPIB Talker/Listener and two 8293 GPIB Transceivers to form a complete IEEE-488 Bus Interface for a microprocessor. The electrical interface is performed by the transceivers, data transfer is done by the talker/listener, and control of the bus is done by the 8292. Figure 3 is a typical controller interface using Intel's GPIB peripherals.

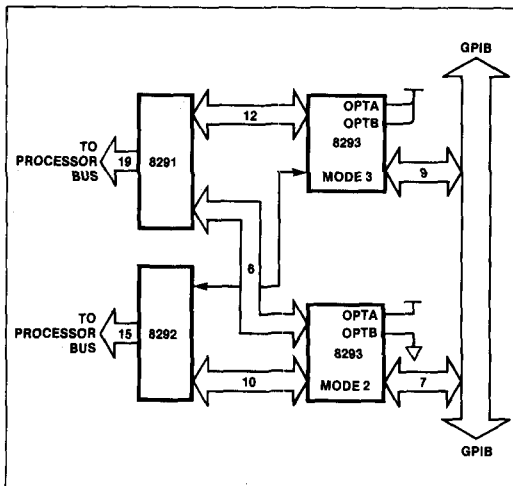

**Figure 3. Talker/Listener/Controller Configuration**

The internal RAM in the 8041A is used as a special purpose register bank for the 8292. Most of these registers (except for the interrupt flag) can be accessed through commands to the 8292. Table 2 identifies the registers used by the 8292 and how they are accessed.

**Interrupt Status Register**

SYC	ERR	SRQ	EV	X	IFCR	IBF	OBF
D <sub>7</sub>				D <sub>0</sub>			

The 8292 can be configured to interrupt the microprocessor on one of several conditions. Upon receipt of the interrupt the microprocessor must read the 8292 interrupt status register to determine which event caused the interrupt, and then the appropriate subroutine can be performed. The interrupt status register is read with A<sub>0</sub> high. With the exception of OBF and IBF, these interrupts are enabled or disabled by the SPI interrupt mask. OBF and IBF have their own bits in the interrupt mask (OBF<sub>I</sub> and IBF<sub>I</sub>).

**OBF** Output Buffer Full. A byte is waiting to be read by the microprocessor. This flag is cleared when the output data bus buffer is read.

**IBF** Input Buffer Full. The byte previously written by the microprocessor has not been read yet by the 8292. If another byte is written to the 8292 before this flag clears, data will be lost. IBF is cleared when the 8292 reads the data byte.

**IFCR** Interface Clear Received. The GPIB system controller has set IFC. The 8292 has become idle and is no longer in charge of the bus. The flag is cleared when the IACK command is issued.

**EV** Event Counter Interrupt. The requested number of blocks or data bytes has been transferred. The EV interrupt flag is cleared by the IACK command.

**SRQ** Service Request. Notifies the 8292 that a service request (SRQ) message has been received. It is cleared by the IACK command.

**ERR** Error occurred. The type of error can be determined by reading the error status register. This interrupt flag is cleared by the IACK command.

**SYC** System Controller Switch Change. Notifies the processor that the state of the system controller switch has changed. The actual state is contained in the GPIB Status Register. This flag is cleared by the IACK command.

**Table 2. 8292 Registers**

READ FROM 8292								WRITE TO 8292							
INTERRUPT STATUS								INTERRUPT MASK							
SYC	ERR	SRQ	EV	X	IFCR	IBF	OBF	1	SPI	TCI	SYC	OBF <sub>I</sub>	IBF <sub>I</sub>	0	SRQ
D <sub>7</sub>				D <sub>0</sub>				D <sub>7</sub>				D <sub>0</sub>			
ERROR FLAG								ERROR MASK							
X	X	USER	X	X	TOUT <sub>3</sub>	TOUT <sub>2</sub>	TOUT <sub>1</sub>	0	0	USER	0	0	TOUT <sub>3</sub>	TOUT <sub>2</sub>	TOUT <sub>1</sub>
CONTROLLER STATUS								COMMAND FIELD							
CSBS	CA	X	X	SYCS	IFC	REN	SRQ	1	1	1	OP	C	C	C	C
GPIB (BUS) STATUS								EVENT COUNTER							
REN	DAV	EOI	X	SYC	IFC	ANTI	SRQ	D	D	D	D	D	D	D	D
EVENT COUNTER STATUS								TIME OUT							
D	D	D	D	D	D	D	D	D	D	D	D	D	D	D	D
TIME OUT STATUS															
D	D	D	D	D	D	D	D								

Note: These registers are accessed by a special utility command, see page 6.

**Interrupt Mask Register**

1	SPI	TCI	SYC	OBF $\overline{I}$	$\overline{IBFI}$	0	SRQ
D <sub>7</sub>				D <sub>0</sub>			

The Interrupt Mask Register is used to enable features and to mask the SPI and TCI interrupts. The flags in the Interrupt Status Register will be active even when masked out. The Interrupt Mask Register is written when A<sub>0</sub> is low and reset by the RINM command. When the register is read, D<sub>1</sub> and D<sub>7</sub> are undefined. An interrupt is enabled by setting the corresponding register bit.

- SRQ** Enable interrupts on SRQ received.
- $\overline{IBFI}$**  Enable interrupts on input buffer empty.
- OBF $\overline{I}$**  Enable interrupts on output buffer full.
- SYC** Enable interrupts on a change in the system controller switch.
- TCI** Enable interrupts on the task completed.
- SPI** Enable interrupts on special events.

NOTE: The event counter is enabled by the GSEC command, the error interrupt is enabled by the error mask register, and IFC cannot be masked (it will always cause an interrupt).

**Controller Status Register**

CSBS	CA	X	X	SYCS	IFC	REN	SRQ
D <sub>7</sub>				D <sub>0</sub>			

The Controller Status Register is used to determine the status of the controller function. This register is accessed by the RCST command.

- SRQ** Service Request line active (CSRS).
- REN** Sending Remote Enable.
- IFC** Sending or receiving interface clear.
- SYCS** System Controller Switch Status (SACS).
- CA** Controller Active (CACS + CAWS + CSWS).
- CSBS** Controller Stand-by State (CSBS, CA) = (0,0) — Controller Idle

**GPIB Bus Status Register**

REN	DAV	EOI	X	SYC	IFC	ATNI	SRQ
D <sub>7</sub>				D <sub>0</sub>			

This register contains GPIB bus status information. It can be used by the microprocessor to monitor and manage the bus. The GPIB Bus Register can be read using the RBST command.

Each of these status bits reflect the current status of the corresponding pin on the 8292.

- SRQ** Service Request
- ATNI** Attention In
- IFC** Interface Clear
- SYC** System Controller Switch
- EOI** End or Identify
- DAV** Data Valid
- REN** Remote Enable

**Event Counter Register**

D <sub>7</sub>	D <sub>6</sub>	D <sub>5</sub>	D <sub>4</sub>	D <sub>3</sub>	D <sub>2</sub>	D <sub>1</sub>	D <sub>0</sub>
----------------	----------------	----------------	----------------	----------------	----------------	----------------	----------------

The Event Counter Register contains the initial value for the event counter. The counter can count pulses on pin 39 of the 8292 (COUNT). It can be connected to EO $\overline{I}$  or NDAC to count blocks or bytes respectively during standby state. A count of zero equals 256. This register cannot be read, and is written using the WEVC command.

**Event Counter Status Register**

D <sub>7</sub>	D <sub>6</sub>	D <sub>5</sub>	D <sub>4</sub>	D <sub>3</sub>	D <sub>2</sub>	D <sub>1</sub>	D <sub>0</sub>
----------------	----------------	----------------	----------------	----------------	----------------	----------------	----------------

This register contains the current value in the event counter. The event counter counts back from the initial value stored in the Event Counter Register to zero and then generates an Event Counter Interrupt. This register cannot be written and can be read using a REVC command.

**Time Out Register**

D <sub>7</sub>	D <sub>6</sub>	D <sub>5</sub>	D <sub>4</sub>	D <sub>3</sub>	D <sub>2</sub>	D <sub>1</sub>	D <sub>0</sub>
----------------	----------------	----------------	----------------	----------------	----------------	----------------	----------------

The Time Out Register is used to store the time used for the time out error function. See the individual timeouts (TOUT<sub>1</sub>, 2, 3) to determine the units of this counter. This Time Out Register cannot be read, and it is written with the WTOUT command.

**Time Out Status Register**

D <sub>7</sub>	D <sub>6</sub>	D <sub>5</sub>	D <sub>4</sub>	D <sub>3</sub>	D <sub>2</sub>	D <sub>1</sub>	D <sub>0</sub>
----------------	----------------	----------------	----------------	----------------	----------------	----------------	----------------

This register contains the current value in the time out counter. The time out counter decrements from the original value stored in the Time Out Register. When zero is reached, the appropriate error interrupt is generated. If the register is read while none of the time out functions are active, the register will contain the last value reached the last time a function was active. The Time Out Status Register cannot be written, and it is read with the RTOUT command.

**Error Flag Register**

X	X	USER	X	X	TOUT <sub>3</sub>	TOUT <sub>2</sub>	TOUT <sub>1</sub>
D <sub>7</sub>				D <sub>0</sub>			

Four errors are flagged by the 8292 with a bit in the Error Flag Register. Each of these errors can be masked by the Error Mask Register. The Error Flag Register cannot be written, and it is read by the IACK command when the error flag in the Interrupt Status Register is set.

**TOUT<sub>1</sub>** Time Out Error 1 occurs when the current controller has not stopped sending ATN after receiving the TCT message for the time period specified by the Time Out Register. Each count in the Time Out Register is at least 1800 t<sub>COY</sub>. After flagging the error, the 8292 will remain in a loop trying to take control until the current controller stops sending ATN or a new command is written by the microprocessor. If a new command is written, the 8292 will return to the loop after executing it.

**TOUT2** Time Out Error 2 occurs when the transmission between the addressed talker and listener has not started for the time period specified by the Time Out Register. Each count in the Time Out Register is at least 45  $t_{CY}$ . This feature is only enabled when the controller is in the CSBS state.

**TOUT3** Time Out Error 3 occurs when the handshake signals are stuck and the 8292 is not succeeding in taking control synchronously for the time period specified by the Time Out Register. Each count in the Time Out Register is at least 1800  $t_{CY}$ . The 8292 will continue checking ATNI until it becomes true or a new command is received. After performing the new command, the 8292 will return to the ATNI checking loop.

**USER** User error occurs when request to assert IFC or REN was received and the 8292 was not the system controller.

**Error Mask Register**

0	0	USER	0	0	TOUT <sub>3</sub>	TOUT <sub>2</sub>	TOUT <sub>1</sub>
D <sub>7</sub>				D <sub>0</sub>			

The Error Mask Register is used to mask the interrupt from a particular type of error. Each type of error interrupt is enabled by setting the corresponding bit in the Error Mask Register. This register can be read with the RERM command and written with A<sub>0</sub> low.

**Command Register**

1	1	1	OP	C	C	C	C
D <sub>7</sub>				D <sub>0</sub>			

Commands are performed by the 8292 whenever a byte is written with A<sub>0</sub> high. There are two categories of commands distinguished by the OP bit (bit 4). The first category is the operation command (OP = 1). These commands initiate some action on the interface bus. The second category is the utility commands (OP = 0). These commands are used to aid the communication between the processor and the 8292.

**OPERATION COMMANDS**

Operation commands initiate some action on the GPIB interface bus. It is using these commands that the control functions such as polling, taking and passing control, and system controller functions are performed. A TCI interrupt is generated upon successful completion of each of these functions.

**F0 — SPCNI — Stop Counter Interrupts**

This command disables the internal counter interrupt so that the 8292 will stop interrupting the master on event counter underflows. However, the counter will continue counting and its contents can still be used.

**F1 — GIDL — Go To Idle**

This command is used during the transfer of control procedure while transferring control to another controller. The 8292 will respond to this command only if it is in the active state.  $\overline{ATNO}$  will go high, and  $\overline{CIC}$  will be high so that this 8292 will no longer be driving the ATN line on the GPIB interface bus.

**F2 — RST — Reset**

This command has the same effect as asserting the external reset on the 8292. For details, refer to the reset procedure described later.

**F3 — RSTI — Reset Interrupts**

This command resets any pending interrupts and clears the error flags. The 8292 will not return to any loop it was in (such as from the time out interrupts).

**F4 — GSEC — Go To Standby, Enable Counting**

The function causes  $\overline{ATNO}$  to go high and the counter will be enabled. If the 8292 was not the active controller, this command will exit immediately. If the 8292 is the active controller, the counter will be loaded with the value stored in the Event Counter Register, and the internal interrupt will be enabled so that when the counter reaches zero, the SPI interrupt will be generated. SPI will be generated every 256 counts thereafter until the controller exits the standby state or the SPCNI command is written. An initial count of 256 (zero in the Event Counter Register) will be used if the WEVC command is not executed. If the data transmission does not start, a TOUT2 error will be generated.

**F5 — EXPP — Execute Parallel Poll**

This command initiates a parallel poll by asserting ATN and EOI (IDY message) true. The 8291 should be previously configured as a listener. Upon detection of DAV true, the 8291 enters ACDS and latches the parallel poll response (PPR) byte into its data in register. The master will be interrupted by the 8291 BI interrupt when the PPR byte is available. No interrupts except the  $\overline{IBFI}$  will be generated by the 8292. The 8292 will respond to this command only when it is the active controller.

**F6 — GTSB — Go To Standby**

If the 8292 is the active controller,  $\overline{ATNO}$  will go high then TCI will be generated. If the data transmission does not start, a TOUT2 error will be generated.

**F7 — SLOC — Set Local Mode**

If the 8292 is the system controller, then REN will be asserted false for at least 100  $\mu$ sec. If it is not the system controller, the User Error bit will be set in the Error Flag Register.

**F8 — SREM — Set interface To Remote Control**

This command will set REN true if this 8292 is the system controller. If not, the User Error bit will be set in the Error Flag Register.

**F9 — ABORT — Abort All Operation, Clear Interface**

This command will cause IFC to be asserted true for at least 100  $\mu$ sec if this 8292 is the system controller. If it is in CIDS, it will take control over the bus (see the TCNTR command).

**FA — TCNTR — Take Control**

The transfer of control procedure is coordinated by the master with the 8291 and 8292. When the master receives a TCT message from the 8291, it should issue the TCNTR command to the 8292. The following events occur to take control:

1. The 8292 checks to see if it is in CIDS, and if not, it exits.
2. Then  $\overline{ATN}$  is checked until it becomes high. If the current controller does not release ATN for the time specified by the Time Out Register, then a TOUT1 error is generated. The 8292 will return to this loop after an error or any command except the RST and RSTI commands.
3. After the current controller releases ATN, the 8292 will assert  $\overline{ATN}$  and  $\overline{CIC}$  low.
4. Finally, the TCI interrupt is generated to inform the master that it is in control of the bus.

**FC — TCASY — Take Control Asynchronously**

TCAS transfers the 8292 from CSBS to CACS independent of the handshake lines. If a bus hangup is detected (by an error flag), this command will force the 8292 to take control (asserting ATN) even if the AH function is not in ANRS (Acceptor Not Ready State). This command should be used very carefully since it may cause the loss of a data byte. Normally, control should be taken synchronously. After checking the controller function for being in the CSBS (else it will exit immediately),  $\overline{ATN}$  will go low, and a TCI interrupt will be generated.

**FD — TCSY — Take Control Synchronously**

There are two different procedures used to transfer the 8292 from CSBS to CACS depending on the state of the 8291 in the system. If the 8291 is in "continuous AH cycling" mode (Aux. Reg. A0=A1=1), then the following procedure should be followed:

1. The master microprocessor stops the continuous AH cycling mode in the 8291;
2. The master reads the 8291 Interrupt Status 1 Register;
3. If the END bit is set, the master sends the TCSY command to the 8292;
4. If the END bit was not set, the master reads the 8291 Data In Register and then waits for another BI interrupt from the 8291. When it occurs, the master sends the 8292 the TCSY command.

If the 8291 is not in AH cycling mode, then the master just waits for a BI interrupt and then sends the TCSY command. After the TCSY command has been issued, the 8292 checks for CSBS. If CSBS, then it exits the routine. Otherwise, it then checks the DAV bit in the GPIB status. When DAV becomes false, the 8292 will

wait for at least 1.5  $\mu$ sec. (T10) and then  $\overline{ATN}$  will go low. If DAV does not go low, a TOUT3 error will be generated.

**FE — STCNI — Start Counter Interrupts**

This command enables the internal counter interrupt. The counter is enabled by the GSEC command.

**UTILITY COMMANDS**

All these commands are either Read or Write to registers in the 8292. Upon completion of Read commands, the TCI (Task Completed Interrupt) will be generated. Note that writing to the Error Mask Register and the Interrupt Mask Register are done directly.

**E1 — WTOUT — Write To Time Out Register**

The byte written to the data bus buffer (with A<sub>0</sub>=0) following this command will determine the time used for the time out function. Since this function is implemented in software, this will not be an accurate time measurement. This feature is enable or disable by the Error Mask Register. No interrupts except for the  $\overline{IBF}$  will be generated upon completion.

**E2 — WEVC — Write To Event Counter**

The byte written to the data bus buffer (with A<sub>0</sub>=0) following this command will be loaded into the Event Counter Register and the Event Counter Status for byte counting or EOI counting. Only  $\overline{IBF}$  will indicate completion of this command.

**E3 — REVC — Read Event Counter Status**

This command transfers the contents of the Event Counter into the data bus buffer. A TCI is generated when the data is available in the data bus buffer.

**E4 — RERF — Read Error Flag Register**

This command transfers the contents of the Error Flag Register into the data bus buffer. A TCI is generated when the data is available.

**E5 — RINM — Read Interrupt Mask Register**

This command transfers the contents of the Interrupt Mask Register into the data bus buffer. This register is available to the processor so that it does not need to store this information elsewhere. A TCI is generated when the data is available in the data bus buffer.

**E6 — RCST — Read Controller Status Register**

This command transfers the contents of the Controller Status Register into the data bus buffer and a TCI interrupt is generated.

**E7 — RBST — Read GPIB Bus Status Register**

This command transfers the contents of the GPIB Bus Status Register into the data bus buffer, and a TCI interrupt is generated when the data is available.

**E9 — RTOU — Read Time Out Status Register**

This command transfers the contents of the Time Out Status Register into the data bus buffer, and a TCI interrupt is generated when the data is available.

**EA — RERM — Read Error Mask Register**

This command transfers the contents of the Error Mask Register to the data bus buffer so that the processor does not need to store this information elsewhere. A TCI interrupt is generated when the data is available.

**Interrupt Acknowledge**

SYC	ERR	SRQ	EV	1	IFCR	1	1
D7				D0			

Each named bit in an Interrupt Acknowledge (IACK) corresponds to a flag in the Interrupt Status Register. When the 8292 receives this command, it will clear the SPI and the corresponding bits in the Interrupt Status Register. If not all the bits were cleared, then the SPI will be set true again. If the error flag is not acknowledged by the IACK command, then the Error Flag Register will be transferred to the data bus buffer, and a TCI will be generated.

NOTE: XXXX1X11 is an undefined operation or utility command, so no conflict exists between the IACK operation and utility commands.

**SYSTEM OPERATION**

**8292 To Master Processor Interface**

Communication between the 8292 and the Master Processor can be either interrupt based communication or based upon polling the interrupt status register in predetermined intervals.

**Interrupt Based Communication**

Four different interrupts are available from the 8292:

- OBF** Output Buffer Full Interrupt
- IBF** Input Buffer Not Full Interrupt
- TCI** Task Completed Interrupt
- SPI** Special Interrupt

Each of the interrupts is enabled or disabled by a bit in the interrupt mask register. Since OBF and IBF are directly connected to the OBF and IBF flags, the master can write a new command to the input data bus buffer as soon as the previous command has been read.

The TCI interrupt is useful when the master is sending commands to the 8292. The pending TCI will be cleared with each new command written to the 8292. Commands sent to the 8292 can be divided into two major groups:

1. Commands that require response back from the 8292 to the master, e.g., reading register.
2. Commands that initiate some action or enable features but do not require response back from the 8292, e.g., enable data bus buffer interrupts.

With the first group, the TCI interrupt will be used to indicate that the required response is ready in the data bus buffer and the master may continue and read it. With the second group, the interrupt will be used to indicate completion of the required task, so that the master may send new commands.

The SPI should be used when immediate information or special events is required (see the Interrupt Status Register).

**“Polling Status” Based Communication**

When interrupt based communication is not desired, all interrupts can be masked by the interrupt mask register. The communication with the 8292 is based upon sequential poll of the interrupt status register. By testing the OBF and IBF flags, the data bus buffer status is determined while special events are determined by testing the other bits.

**Receiving IFC**

The IFC pulse defined by the IEEE-488 standard is at least 100 μsec. In this time, all operation on the bus should be aborted. Most important, the current controller (the one that is in charge at that time) should stop sending ATN or EOI. Thus, IFC must externally gate CIC (controller in charge) and ATNO to ensure that this occurs.

**Reset and Power Up Procedure**

After the 8292 has been reset either by the external reset pin, the device being powered on, or a RST command, the following sequential events will take place:

1. All outputs to the GPIB interface will go high (SRQ, ATNI, IFC, CLTH, ATNO, CIC, TCI, SPI, EOI, OBF, IBF, DAV, REV).
2. The four interrupt outputs (TCI, SPI, OBF, IBF) and CLTH output will go low.
3. The following registers will be cleared:
  - Interrupt Status
  - Interrupt Mask
  - Error Flag
  - Error Mask
  - Time Out
  - Event Counter (= 256), Counter is disabled.
4. If the 8292 is the system controller, an ABORT command will be executed, the 8292 will become the controller in charge, and it will enter the CACS state. If it is not the system controller, it will remain in CIDS.

**System Configuration**

The 8291 and 8292 must be interfaced to an IEEE-488 bus meeting a variety of specifications including drive capability and loading characteristics. To interface the 8291 and the 8292 without the 8293's, several external gates are required, using a configuration similar to that used in Figure 5.

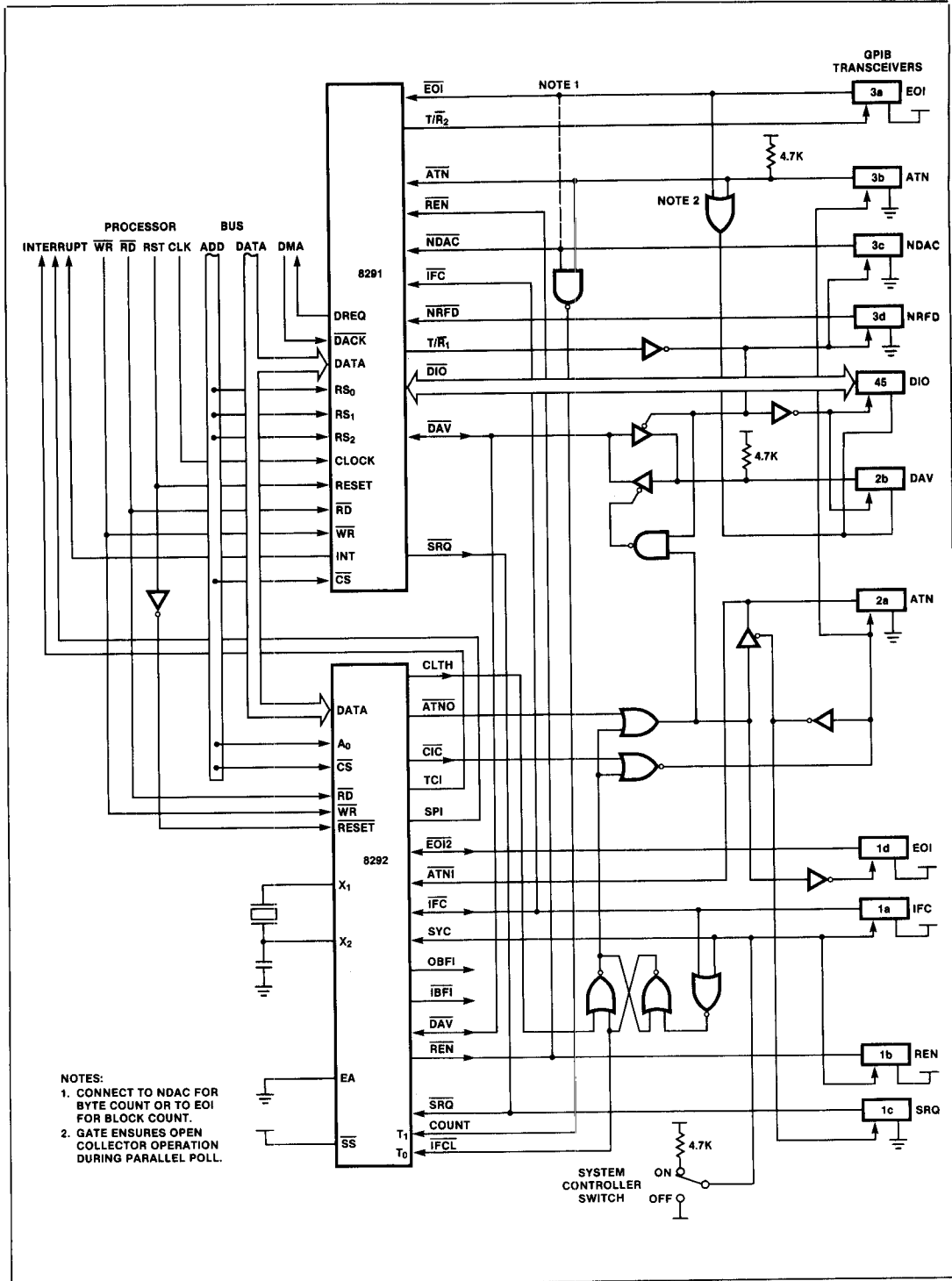

Figure 4. 8291 and 8292 System Configuration





**ABSOLUTE MAXIMUM RATINGS\***

Ambient Temperature Under Bias . . . . . 0°C to 70°C  
 Storage Temperature . . . . . -65°C to +150°C  
 Voltage on Any Pin With Respect  
   to Ground . . . . . 0.5V to +7V  
 Power Dissipation . . . . . 1.5 Watt

*\*NOTICE: Stresses above those listed under "Absolute Maximum Ratings" may cause permanent damage to the device. This is a stress rating only and functional operation of the device at these or any other conditions above those indicated in the operational sections of this specification is not implied. Exposure to absolute maximum rating conditions for extended periods may affect device reliability.*

**D.C. CHARACTERISTICS** ( $T_A = 0^\circ\text{C}$  to  $70^\circ\text{C}$ ,  $V_{SS} = 0\text{V}$ ; 8292,  $V_{CC} = \pm 5\text{V} \pm 10\%$ )

Symbol	Parameter	Min.	Max.	Unit	Test Conditions
$V_{IL1}$	Input Low Voltage (All Except $X_1$ , $X_2$ , $\overline{\text{RESET}}$ )	-0.5	0.8	V	
$V_{IL2}$	Input Low Voltage ( $X_1$ , $X_2$ , $\overline{\text{RESET}}$ )	-0.5	0.6	V	
$V_{IH1}$	Input High Voltage (All Except $X_1$ , $X_2$ , $\overline{\text{RESET}}$ )	2.2	$V_{CC}$	V	
$V_{IH2}$	Input High Voltage ( $X_1$ , $X_2$ , $\overline{\text{RESET}}$ )	3.8	$V_{CC}$	V	
$V_{OL1}$	Output Low Voltage ( $D_0$ - $D_7$ )		0.45	V	$I_{OL} = 2.0 \text{ mA}$
$V_{OL2}$	Output Low Voltage (All Other Outputs)		0.45	V	$I_{OL} = 1.6 \text{ mA}$
$V_{OH1}$	Output High Voltage ( $D_0$ - $D_7$ )	2.4		V	$I_{OH} = -400 \mu\text{A}$
$V_{OH2}$	Output High Voltage (All Other Outputs)	2.4		V	$I_{OH} = -50 \mu\text{A}$
$I_{IL}$	Input Leakage Current ( $\overline{\text{COUNT}}$ , $\overline{\text{IFCL}}$ , $\overline{\text{RD}}$ , $\overline{\text{WR}}$ , $\overline{\text{CS}}$ , $A_0$ )		$\pm 10$	$\mu\text{A}$	$V_{SS} \leq V_{IN} \leq V_{CC}$
$I_{OZ}$	Output Leakage Current ( $D_0$ - $D_7$ , High Z State)		$\pm 10$	$\mu\text{A}$	$V_{SS} + 0.45 \leq V_{IN} \leq V_{CC}$
$I_{LI1}$	Low Input Load Current (Pins 21-24, 27-38)		0.5	mA	$V_{IL} = 0.8\text{V}$
$I_{LI2}$	Low Input Load Current ( $\overline{\text{RESET}}$ )		0.2	mA	$V_{IL} = 0.8\text{V}$
$I_{CC}$	Total Supply Current		125	mA	Typical = 65 mA
$I_{IH}$	Input High Leakage Current (Pins 21-24, 27-38)		100	$\mu\text{A}$	$V_{IN} = V_{CC}$
$C_{IN}$	Input Capacitance		10	pF	
$C_{I/O}$	I/O Capacitance		20	pF	

**A.C. CHARACTERISTICS** ( $T_A = 0^\circ\text{C}$  to  $70^\circ\text{C}$ ,  $V_{SS} = 0\text{V}$ ; 8292,  $V_{CC} = +5\text{V} \pm 10\%$ )

**DBB READ**

Symbol	Parameter	Min.	Max.	Unit	Test Conditions
$t_{AR}$	$\overline{\text{CS}}$ , $A_0$ Setup to $\overline{\text{RD}}\downarrow$	0		ns	
$t_{RA}$	$\overline{\text{CS}}$ , $A_0$ Hold After $\overline{\text{RD}}\uparrow$	0		ns	
$t_{RR}$	$\overline{\text{RD}}$ Pulse Width	250		ns	
$t_{AD}$	$\overline{\text{CS}}$ , $A_0$ to Data Out Delay		225	ns	$C_L = 150 \text{ pF}$
$t_{RD}$	$\overline{\text{RD}}\downarrow$ to Data Out Delay		225	ns	$C_L = 150 \text{ pF}$
$t_{DF}$	$\overline{\text{RD}}\uparrow$ to Data Float Delay		100	ns	
$t_{CY}$	Cycle Time	2.5	15	$\mu\text{s}$	

**DBB WRITE**

Symbol	Parameter	Min.	Max.	Unit	Test Conditions
$t_{AW}$	$\overline{\text{CS}}$ , $A_0$ Setup to $\overline{\text{WR}}\downarrow$	0		ns	
$t_{WA}$	$\overline{\text{CS}}$ , $A_0$ Hold After $\overline{\text{WR}}\uparrow$	0		ns	
$t_{WW}$	$\overline{\text{WR}}$ Pulse Width	250		ns	
$t_{DW}$	Data Setup to $\overline{\text{WR}}\uparrow$	150		ns	
$t_{WD}$	Data Hold After $\overline{\text{WR}}\downarrow$	0		ns	

**COMMAND TIMINGS**<sup>[1,3]</sup>

Code	Name	Execution Time	IBF↑	TCI <sup>[2]</sup>	SPI	ATNO	CIC	IFC	REN	EOI	DAV	Comments
E1	WTOUT	63	24									
E2	WEVC	63	24									
E3	REVC	71	24	51								
E4	RERF	67	24	47								
E5	RINM	69	24	49								
E6	RCST	97	24	77								
E7	RBST	92	24	72								
E8												
E9	RTOUT	69	24	49								
EA	RERM	69	24	49								
F0	SPCNI	53	24									Count Stops After 39
F1	GIOL	88	24	70		↑61	↑61					
F2	RST	94	24		↓52							Not System Controller
F2	RST	214	24	192	↓52	↑179	↑174	↑101				System Controller
F3	RSTI	61	24									
F4	GSEC	125	24	107		↑98						
F5	EXPP	75	24						↓53 ↑59	↓55 ↑57		
F6	GTSB	118	24	100		↑91						
F7	SLOC	73	24	55				↑46				
F8	SREM	91	24	73				↑64				
F9	ABORT	155	24	133		↑120	↑115	↑42				
FA	TCNTR	108	24	86		↑71	↑68					
FC	TCAS	92	24	67		↓55						
FD	TCSY	115	24	91		↑80						
FE	STCNI	59	24									Starts Count After 43
PIN	RESET	29	—	↓7	↓7							Not System Controller
X	IACK	116	—			↓73 ↑98						If Interrupt Pending

Notes:

1. All times are multiples of  $t_{CY}$  from the 8041A command interrupt.
2. TCI clears after 7  $t_{CY}$  on all commands.
3. ↑ indicates a level transition from low to high, ↓ indicates a high to low transition.

**A.C. TESTING INPUT, OUTPUT WAVEFORM**

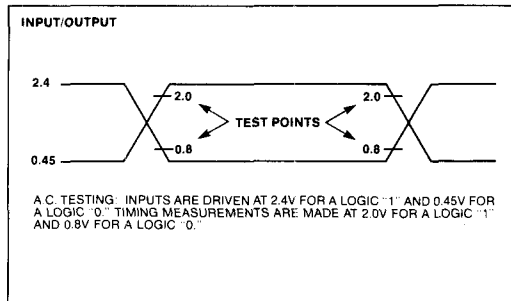

**A.C. TESTING LOAD CIRCUIT**

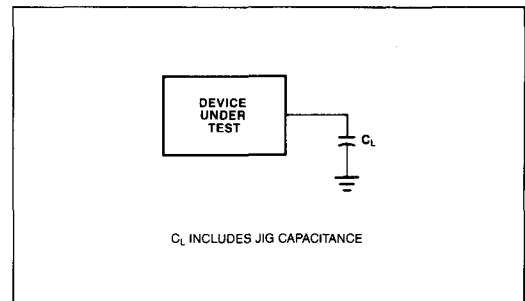

**CLOCK DRIVER CIRCUITS**

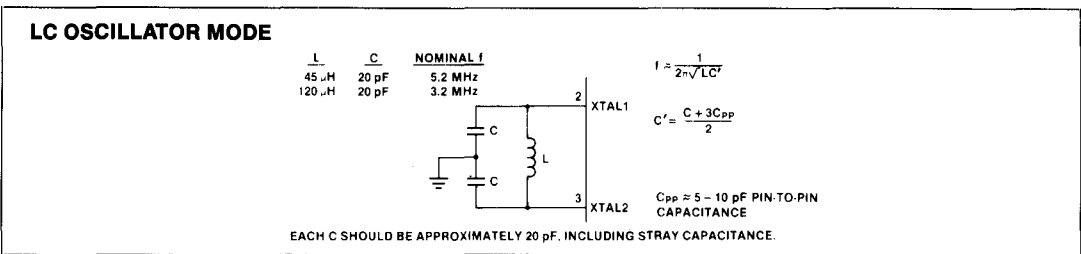
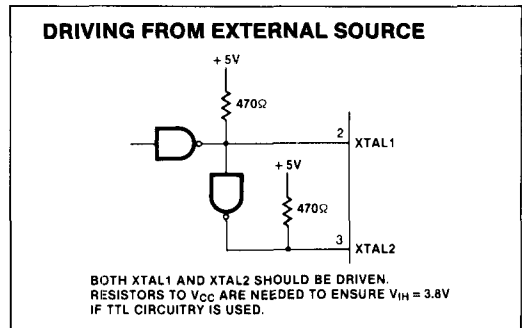
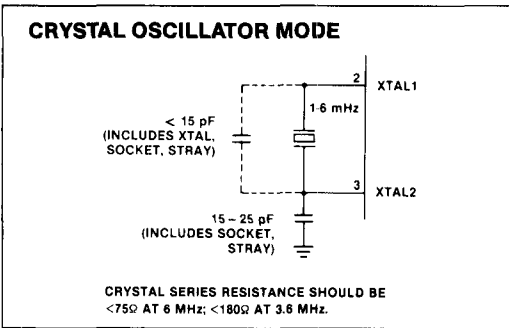

**WAVEFORMS**

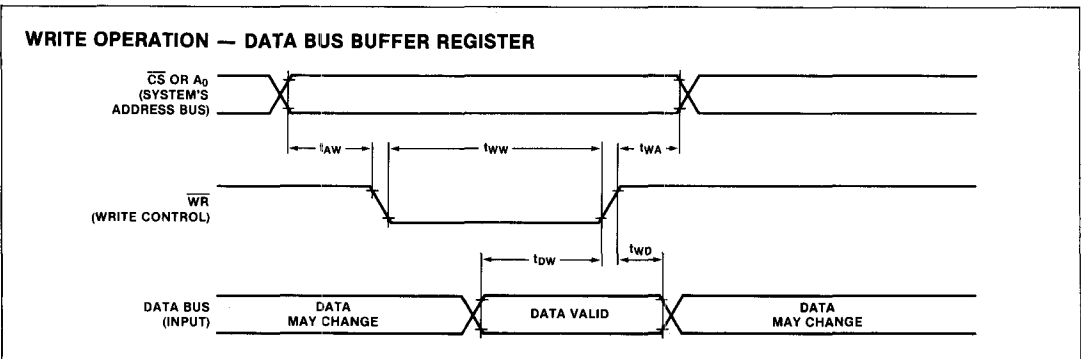
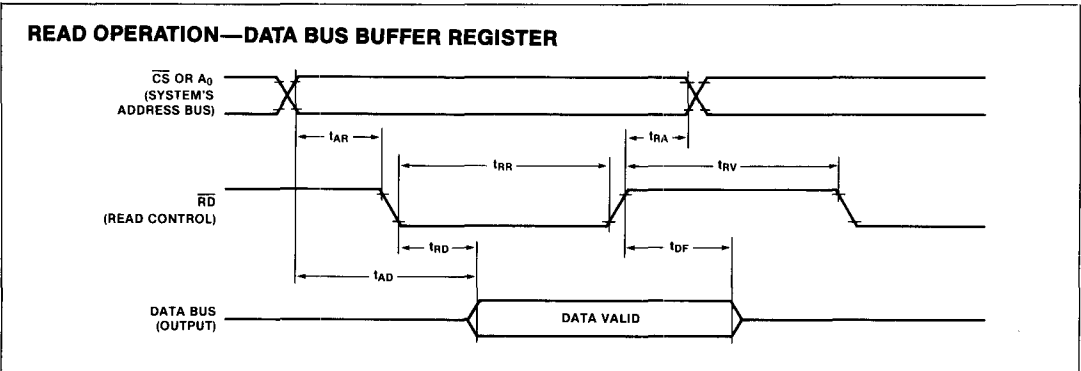

APPENDIX

The following tables and state diagrams were taken from the IEEE Standard Digital Interface for Program-

mable Instrumentation, IEEE Std. 488-1978. This document is the official standard for the GPIB bus and can be purchased from IEEE, 345 East 47th St., New York, NY 10017.

C MNEMONICS

Messages	Interface States
pon = power on	CIDS = controller idle state
rsc = request system control	CADS = controller addressed state
rpp = request parallel poll	CTRS = controller transfer state
gts = go to standby	CACS = controller active state
tca = take control asynchronously	CPWS = controller parallel poll wait state
tcs = take control synchronously	CPPS = controller parallel poll state
sic = send interface clear	CSBS = controller standby state
sre = send remote enable	CSHS = controller standby hold state
IFC = interface clear	CAWS = controller active wait state
ATN = attention	CSWS = controller synchronous wait state
TCT = take control	CSRS = controller service requested state
	CSNS = controller service not requested state
	SNAS = system control not active state
	SACS = system control active state
	SRIS = system control remote enable idle state
	SRNS = system control remote enable not active state
	SRAS = system control remote enable active state
	SIIS = system control interface clear idle state
	SINS = system control interface clear not active state
	SIAS = system control interface clear active state
	(ACDS) = accept data state (AH function)
	(ANRS) = acceptor not ready state (AH function)
	(SDYS) = source delay state (SH function)
	(STRS) = source transfer state (SH function)
	(TADS) = talker addressed state (T function)

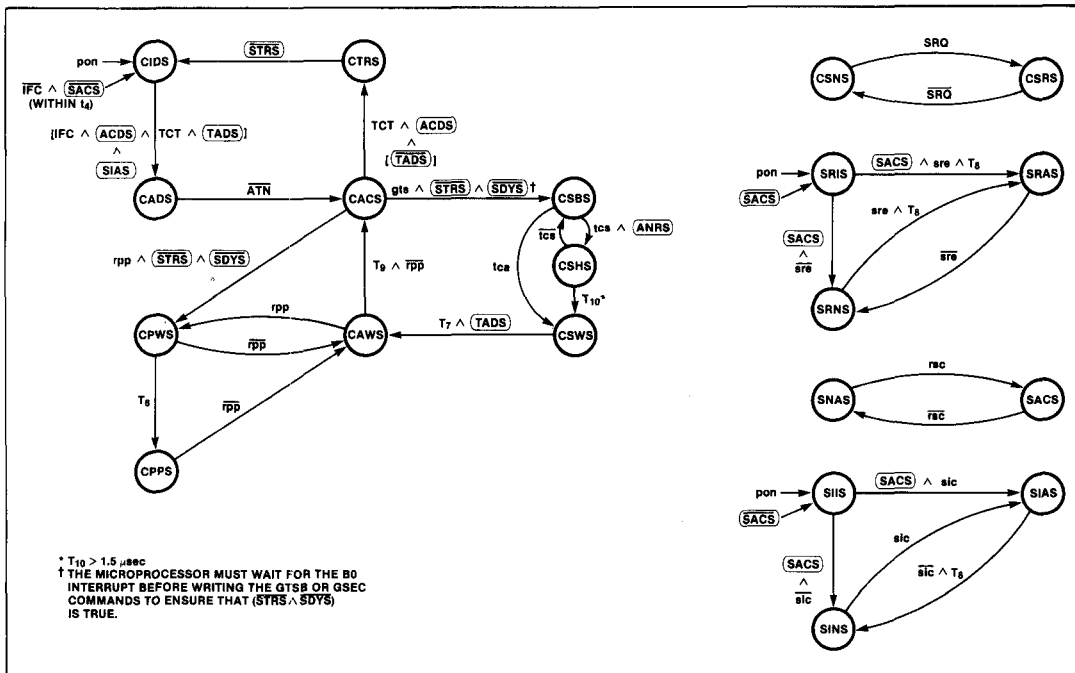

Figure A.1. C State Diagram

REMOTE MESSAGE CODING

Mnemonic	Message Name	TYPE	CLASS	Bus Signal Line(s) and Coding That Asserts the True Value of the Message																	
				DIO8	DIO7	DIO6	DIO5	DIO4	DIO3	DIO2	DIO1	NNDRD	AFVDC	A	T	E	R	S	I	R	E
ACG	Addressed Command Group	M	AC	Y	0	0	0	X	X	X	X	XXX	1	X	X	X	X				
ATN	Attention	U	UC	X	X	X	X	X	X	X	X	XXX	1	X	X	X	X				
DAB	Data Byte	M	DD	D	D	D	D	D	D	D	D	XXX	0	X	X	X	X				
	(Notes 1, 9)			8	7	6	5	4	3	2	1										
DAC	Data Accepted	U	HS	X	X	X	X	X	X	X	X	XX0	X	X	X	X	X				
DAV	Data Valid	U	HS	X	X	X	X	X	X	X	X	1XX	X	X	X	X	X				
DCL	Device Clear	M	UC	Y	0	0	1	0	1	0	0	XXX	1	X	X	X	X				
END	End	U	ST	X	X	X	X	X	X	X	X	XXX	0	1	X	X	X				
EOS	End of String	M	DD	E	E	E	E	E	E	E	E	XXX	0	X	X	X	X				
	(Notes 2, 9)			8	7	6	5	4	3	2	1										
GET	Group Execute Trigger	M	AC	Y	0	0	0	1	0	0	0	XXX	1	X	X	X	X				
GTL	Go to Local	M	AC	Y	0	0	0	0	0	0	1	XXX	1	X	X	X	X				
IDY	Identify	U	UC	X	X	X	X	X	X	X	X	XXX	X	1	X	X	X				
IFC	Interface Clear	U	UC	X	X	X	X	X	X	X	X	XXX	X	X	X	1	X				
LAG	Listen Address Group	M	AD	Y	0	1	X	X	X	X	X	XXX	1	X	X	X	X				
LLO	Local Lock Out	M	UC	Y	0	0	1	0	0	0	1	XXX	1	X	X	X	X				
MLA	My Listen Address	M	AD	Y	0	1	L	L	L	L	L	XXX	1	X	X	X	X				
	(Note 3)						5	4	3	2	1										
MTA	My Talk Address	M	AD	Y	1	0	T	T	T	T	T	XXX	1	X	X	X	X				
	(Note 4)						5	4	3	2	1										
MSA	My Secondary Address	M	SE	Y	1	1	S	S	S	S	S	XXX	1	X	X	X	X				
	(Note 5)						5	4	3	2	1										
NUL	Null Byte	M	DD	0	0	0	0	0	0	0	0	XXX	X	X	X	X	X				
OSA	Other Secondary Address	M	SE																		
OTA	Other Talk Address	M	AD																		
	(OSA = SCG ^ MSA)																				
	(OTA = TAG ^ MTA)																				
PCG	Primary Command Group	M	—																		
	(PCG = ACG v UCG v LAG v TAG)																				
PPC	Parallel Poll Configure	M	AC	Y	0	0	0	0	1	0	1	XXX	1	X	X	X	X				
PPE	Parallel Poll Enable	M	SE	Y	1	1	0	S	P	P	P	XXX	1	X	X	X	X				
	(Note 6)								3	2	1										
PPD	Parallel Poll Disable	M	SE	Y	1	1	1	D	D	D	D	XXX	1	X	X	X	X				
	(Note 7)								4	3	2	1									
PPR1	Parallel Poll Response 1	U	ST	X	X	X	X	X	X	X	1	XXX	1	1	X	X	X				
PPR2	Parallel Poll Response 2	U	ST	X	X	X	X	X	X	1	X	XXX	1	1	X	X	X				
PPR3	Parallel Poll Response 3	U	ST	X	X	X	X	X	1	X	X	XXX	1	1	X	X	X				
PPR4	Parallel Poll Response 4	U	ST	X	X	X	X	1	X	X	X	XXX	1	1	X	X	X				
PPR5	Parallel Poll Response 5	U	ST	X	X	X	1	X	X	X	X	XXX	1	1	X	X	X				
PPR6	Parallel Poll Response 6	U	ST	X	X	1	X	X	X	X	X	XXX	1	1	X	X	X				
PPR7	Parallel Poll Response 7	U	ST	X	1	X	X	X	X	X	X	XXX	1	1	X	X	X				
PPR8	Parallel Poll Response 8	U	ST	1	X	X	X	X	X	X	X	XXX	1	1	X	X	X				
PPU	Parallel Poll Unconfigure	M	UC	Y	0	0	1	0	1	0	1	XXX	1	X	X	X	X				
REN	Remote Enable	U	UC	X	X	X	X	X	X	X	X	XXX	X	X	X	X	1				
RFD	Ready for Data	U	HS	X	X	X	X	X	X	X	X	X0X	X	X	X	X	X				
RQS	Request Service	U	ST	X	1	X	X	X	X	X	X	XXX	0	X	X	X	X				
SCG	Secondary Command Group	M	SE	Y	1	1	X	X	X	X	X	XXX	1	X	X	X	X				
SDC	Selected Device Clear	M	AC	Y	0	0	0	1	0	0	XXX	1	X	X	X	X	X				
SPD	Serial Poll Disable	M	UC	Y	0	0	1	1	0	0	1	XXX	1	X	X	X	X				
SPE	Serial Poll Enable	M	UC	Y	0	0	1	1	0	0	0	XXX	1	X	X	X	X				
SRQ	Service Request	U	ST	X	X	X	X	X	X	X	X	XXX	X	X	1	X	X				
STB	Status Byte	M	ST	S	X	S	S	S	S	S	S	XXX	0	X	X	X	X				
	(Notes 8, 9)			8	6	5	4	3	2	1											
TCT	Take Control	M	AC	Y	0	0	0	1	0	0	1	XXX	1	X	X	X	X				
TAG	Talk Address Group	M	AD	Y	1	0	X	X	X	X	X	XXX	1	X	X	X	X				
UCG	Universal Command Group	M	UC	Y	0	0	1	X	X	X	X	XXX	1	X	X	X	X				
UNL	Unlisten	M	AD	Y	0	1	1	1	1	1	1	XXX	1	X	X	X	X				
UNT	Untalk	M	AD	Y	1	0	1	1	1	1	1	XXX	1	X	X	X	X				
	(Note 11)																				

The 1/0 coding on ATN when sent concurrent with multiline messages has been added to this revision for interpretive convenience.

NOTES:

1. D1-D8 specify the device dependent data bits.
2. E1-E8 specify the device dependent code used to indicate the EOS message.
3. L1-L5 specify the device dependent bits of the device's listen address.
4. T1-T5 specify the device dependent bits of the device's talk address.
5. S1-S5 specify the device dependent bits of the device's secondary address.
6. S specifies the sense of the PPR.

$$\text{Response} = \overline{S} \oplus \text{lst}$$

P1-P3 specify the PPR message to be sent when a parallel poll is executed.

P3	P2	P1	PPR Message
0	0	0	PPR1
.	.	.	.
.	.	.	.
1	1	1	PPR8

7. D1-D4 specify don't-care bits that shall not be decoded by the receiving device. It is recommended that all zeroes be sent.
8. S1-S6, S8 specify the device dependent status. (DIO7 is used for the RQS message.)
9. The source of the message on the ATN line is always the C function, whereas the messages on the DIO and EOI lines are enabled by the T function.
10. The source of the messages on the ATN and EOI lines is always the C function, whereas the source of the messages on the DIO lines is always the PP function.
11. This code is provided for system use, see 6.3.