



---

# Vacuum Control

## Catalog 2010

---

VACUUM GAUGES, VALVES, FITTINGS  
AND FEEDTHROUGHS



# Table of Contents

## VACUUM GAUGES

### SKY<sup>®</sup> Capacitance Diaphragm Gauge

CDG025D, CDG025D-S .....	A1
CDG025D-X3 .....	A5
CDG045 .....	A9
CDG100D .....	A14
CDG160D, CDG200D .....	A20
AllCeramic <sup>™</sup> CDG025-C .....	A25
AllCeramic <sup>™</sup> CDG160A-C / CDG160A-CS .....	A27

### Bayard-Alpert Pirani Gauge

BPG400 .....	A30
BPG402-S .....	A34

### High Pressure Hot Ionization Pirani Gauge

HPG400 .....	A38
--------------	-----

### Bayard-Alpert Pirani Capacitance Diaphragm Gauge

TripleGauge <sup>®</sup> BCG450 .....	A42
---------------------------------------	-----

### Pirani Standard Gauge

PSG050 / PSG051 .....	A47
PSG100-S, PSG101-S .....	A49
PSG500/-S, PSG502-S, PSG510-S, PSG512-S .....	A52

### Pirani Capacitance Diaphragm Gauge

PCG400, PCG410 .....	A56
PCG550, PCG552, PCG554 .....	A59

### Penning Gauge

PEG100 .....	A65
--------------	-----

### Inverted Magnetron Pirani Gauge

MPG400/401 .....	A68
------------------	-----

### Vacuum Gauge Controllers

VGC401, VGC402, VGC403 .....	A71
PGD400 .....	A73

### Vacuum Switch

VSA100A .....	A75
VSC150A .....	A77

### Calibration Service

Vacuum Gauges .....	A80
---------------------	-----

## VACUUM FEEDTHROUGHS

### Rotary Feedthroughs ISO-KF / ISO-K

FRH DN 16 - DN 63 .....	B1
-------------------------	----

### Rotary Feedthroughs CF

FRU DN 16 - DN 40 .....	B3
-------------------------	----

### Rotary/Linear Motion Feedthroughs ISO-KF

FCH DN 16 - DN 40 .....	B5
-------------------------	----

### Linear Motion Feedthroughs CF

FPU DN 16 - DN 40 .....	B7
-------------------------	----

### Electrical Feedthroughs

DN 16 ISO-KF .....	B9
DN 40 ISO KF .....	B11
DN 16 CF .....	B13
DN 40 CF .....	B15
DN 40 ISO KF .....	B17

### Coaxial Feedthroughs ISO-KF / CF-F

BNC / MHV DN 16 - 40 .....	B19
----------------------------	-----

### Vacuum Feedthroughs

METAL-CERAMIC CONNECTIONS .....	B21
---------------------------------	-----

### Liquid Feedthroughs ISO-KF / CF-F

DN 40 .....	B23
-------------	-----

### Viewports

DN 25 - DN 50 ISO-KF .....	B25
DN 63 - DN 160 ISO-K .....	B27
DN 16 - DN 160 CF .....	B29
DN 63 - DN 160 ISO-F .....	B31

### Vacuum Feedthroughs

VACUUM BALL BEARINGS .....	B33
LUBRICANTS AND SEALING MATERIALS .....	B35

## VACUUM VALVES

### Angle and Inline Valves (VAH, VAP, VAM, VIM)

ISO-KF DN 5 manually, pneumatically, solenoid . . . . .	C1
---	----

### Angle and Inline Valves (VAH, VIH, VAP, VIP)

ISO-KF DN16 - 40 manually . . . . .	C4
ISO-KF DN16 - 40 manually (Diaphragm Valves) . . . . .	C8
ISO-KF DN16 - 40 pneumatically . . . . .	C10
ISO-KF/CF-R DN16 - 40 pneumatically . . . . .	C14
ISO-KF DN16 - 40 solenoid . . . . .	C19
ISO-KF DN63 manually, pneumatically . . . . .	C22
ISO-KF DN100 manually, pneumatically . . . . .	C25
ISO-KF DN160 pneumatically . . . . .	C28

### Butterfly Valves (VBH, VBP)

ISO-KF DN63 - 160 manually . . . . .	C30
ISO-KF DN63 - 250 pneumatically . . . . .	C32

### Dosing Valves (VDH)

ISO-KF DN10 manually (coarse gas dosing) . . . . .	C38
ISO-KF DN16 manually (fine gas dosing / shut-off) . . . . .	C39

### Dosing Systems (VDM, VDE, VCE, VCC, VCA)

All-Metal Dosing Valves and System . . . . .	C41
Gas Dosing Systems . . . . .	C44
Solenoid Control Valves . . . . .	C49

### All-Metal Angle Valves (VAH)

CF-R DN16 - 63 manually . . . . .	C51
-----------------------------------	-----

### Venting Valves (VWH, WWM, VIN)

ISO-KF DN10 manually . . . . .	C53
ISO-KF DN10 solenoid . . . . .	C54
ISO-KF DN10 solenoid (power failure) . . . . .	C56

### Safety Valves (VSM)

ISO-KF DN16 - 100 . . . . .	C57
-----------------------------	-----

### Pressure Relief Valve (VSA)

ISO-KF DN16 . . . . .	C59
-----------------------	-----

### Ball Valves

ISO-KF DN10 - 40 . . . . .	C60
----------------------------	-----

## VACUUM FITTINGS

### ISO-KF Small Flange Components

CONNECTION ELEMENTS .....	D1
SEALS .....	D3
FLANGES .....	D6
PIPE FITTINGS .....	D7
BELLOWS/HOSE WITH FLANGES .....	D9
TRANSITION PIECES .....	D11
HOSE, HOSE CONNECTION .....	D14

### ISO-K Clamp Flange Components

CONNECTION ELEMENTS .....	D16
SEALS .....	D17
FLANGES .....	D20
PIPE FITTINGS .....	D22
BELLOWS / HOSE WITH FLANGES .....	D24
TRANSITION PIECES .....	D25
PROTECTIVE LIDS .....	D26

### ISO-F Fixed Flange Components

FLANGE COMPONENTS .....	D27
-------------------------	-----

### UHV CF Components

CONNECTION ELEMENTS .....	D29
SEALS .....	D30
FLANGES .....	D32
PIPE FITTINGS .....	D36
BELLOWS / HOSE WITH FLANGES, COMPENSATOR .....	D38
TRANSITION PIECES .....	D39
PROTECTIVE LIDS .....	D40

### Website



---

# Vacuum Gauges

---

## VACUUM GAUGES

### SKY<sup>®</sup> Capacitance Diaphragm Gauge

CDG025D, CDG025D-S . . . . .	A1
CDG025D-X3 . . . . .	A5
CDG045 . . . . .	A9
CDG100D . . . . .	A14
CDG160D, CDG200D . . . . .	A20
AllCeramic™ CDG025-C . . . . .	A25
AllCeramic™ CDG160A-C / CDG160A-CS . . . . .	A27

### Bayard-Alpert Pirani Gauge

BPG400 . . . . .	A30
BPG402-S . . . . .	A34

### High Pressure Hot Ionization Pirani Gauge

HPG400 . . . . .	A38
------------------	-----

### Bayard-Alpert Pirani Capacitance Diaphragm Gauge

TripleGauge® BCG450 . . . . .	A42
-------------------------------	-----

### Pirani Standard Gauge

PSG050 / PSG051 . . . . .	A47
PSG100-S, PSG101-S . . . . .	A49
PSG500/-S, PSG502-S, PSG510-S, PSG512-S . . . . .	A52

### Pirani Capacitance Diaphragm Gauge

PCG400, PCG410 . . . . .	A56
PCG550, PCG552, PCG554 . . . . .	A59

### Penning Gauge

PEG100 . . . . .	A65
------------------	-----

### Inverted Magnetron Pirani Gauge

MPG400/401 . . . . .	A68
----------------------	-----

## VACUUM GAUGES (continued)

### Vacuum Gauge Controllers

VGC401, VGC402, VGC403.....	A71
PGD400 .....	A73

### Vacuum Switch

VSA100A.....	A75
VSC150A .....	A77

### Calibration Service

Vacuum Gauges.....	A80
--------------------	-----

### Website



# SKY® Capacitance Diaphragm Gauge

## CDG025D, CDG025D-S

The INFICON SKY CDG025D Capacitance Diaphragm Gauge line of highly accurate temperature compensated manometers is designed for stable performance in harsh manufacturing tool environments. Advanced digital electronics improve gauge performance and offer easy handling features such as one pushbutton zero function and setpoint adjustment. The corrosion resistant ultra pure ceramic sensor provides excellent zero stability with a long life expectancy of several million pressure cycles, including atmospheric bursts. A unique sensor shielding (patent pending) protects the gauge from process contamination. A robust mechanical design and digital electronics improve EMC compatibility, long term stability and temperature compensation. The CDG025D sets new standards for fast stability after power on and fast recovery from atmospheric pressure exposure.



### Advantages

- Full scale ranges from 100 mTorr ... 1000 Torr
- Fast stability after power on
- Fast recovery from atmospheric pressure
- Corrosion resistant ceramic sensor
- Excellent long term signal stability
- Temperature compensated
- Sensor protected from contamination
- One pushbutton zero function
- Wide range power supply
- 2 setpoints (optional)
- RS232 interface (optional)

### Applications

- Semiconductor manufacturing equipment for Etch, CVD, PVD, ALD
- Data storage and display manufacturing equipment
- Industrial vacuum equipment
- General high accuracy pressure measurement

## CDG025D, CDG025D-S (continued)

### Ordering Information

#### CDG025D, temperature compensated

Full Scale Range			Flange type			
Torr	Pascal	mbar	1/2" tube	DN 16 ISO-KF	DN 16 CF-R	8 VCR®
<b>1000</b>	<b>133,322</b>	<b>1333</b>	<b>375-000</b>	<b>375-001</b>	<b>375-002</b>	<b>375-003</b>
<b>100</b>	<b>13,332</b>	<b>133</b>	<b>376-000</b>	<b>376-001</b>	<b>376-002</b>	<b>376-003</b>
<b>10</b>	<b>1,333</b>	<b>13.3</b>	<b>377-000</b>	<b>377-001</b>	<b>377-002</b>	<b>377-003</b>
<b>1</b>	<b>133</b>	<b>1.3</b>	<b>378-000</b>	<b>378-001</b>	<b>378-002</b>	<b>378-003</b>
<b>0.1</b>	<b>13.3</b>	<b>0.13</b>	<b>379-000</b>	<b>379-001</b>	<b>379-002</b>	<b>379-003</b>

#### CDG025D, with 2 setpoints and RS232 interface, temperature compensated

Full Scale Range			Flange type			
Torr	Pascal	mbar	1/2" tube	DN 16 ISO-KF	DN 16 CF-R	8 VCR®
<b>1000</b>	<b>133,322</b>	<b>1333</b>	<b>375-300</b>	<b>375-301</b>	<b>375-302</b>	<b>375-303</b>
-	110,000	1,100	375-500	375-501	375-502	375-503
200	26,664	267	382-300	382-301	382-302	382-303
<b>100</b>	<b>13,332</b>	<b>133</b>	<b>376-300</b>	<b>376-301</b>	<b>376-302</b>	<b>376-303</b>
-	10,000	100	376-500	376-501	376-502	376-503
20	2,666	26.7	383-300	383-301	383-302	383-303
<b>10</b>	<b>1,333</b>	<b>13.3</b>	<b>377-300</b>	<b>377-301</b>	<b>377-302</b>	<b>377-303</b>
-	1,000	10	377-500	377-501	377-502	377-503
<b>1</b>	<b>133</b>	<b>1.3</b>	<b>378-300</b>	<b>378-301</b>	<b>378-302</b>	<b>378-303</b>
-	100	1	378-500	378-501	378-502	378-503
0.25	33.3	0.33	385-300	385-301	385-302	385-303
<b>0.1</b>	<b>13.3</b>	<b>0.13</b>	<b>379-300</b>	<b>379-301</b>	<b>379-302</b>	<b>379-303</b>
-	10	0.1	379-500	379-501	379-502	379-503

**bold** = standard products

Other flange types and full scale ranges on request.

## CDG025D, CDG025D-S (continued)

**Specifications (Torr based standard products)**

Measurement Range F.S. (Full Scale)	Torr Pa mbar	1000 133,322 1333	100 13,332 133	10 1,333 13.3	1 133 1.3	0.1 13 0.13
Accuracy <sup>1)</sup>	% of reading	0.2	0.2	0.2	0.2	0.5
Temperature effect on zero	% F.S./°C	0.005	0.005	0.005	0.015	0.02
on span	% of reading/°C	0.01	0.01	0.01	0.01	0.03
Resolution	% F.S.	0.003	0.003	0.003	0.003	0.003
<b>Pressure, max.</b>	<b>kPa (absolute)</b>	<b>400</b>	<b>260</b>	<b>260</b>	<b>260</b>	<b>130</b>
Response time <sup>2)</sup>	ms	30	30	30	30	130
Lowest reading	% F.S.			0.01		
Lowest suggested reading	% F.S.			0.05		
Lowest suggested control pressure	% F.S.			0.5		
Temperature Operation (ambient)	°C			+5 ... +50		
Bakeout at flange <sup>3)</sup>	°C			≤110		
Storage	°C			-40 ... +65		
Supply voltage	VDC			14 ... 30		
Power consumption	W			≤1		
Output signal (analog)	VDC			0 ... +10		
Response time	ms			30		130
Degree of protection				IP 30		
Standards		EN 61000-6-2, EN 61000-6-3, EN 61010, UL 61010-1, CSA 22.2 No.61010-1, RoHS				
Electrical connection		D-sub, 15 pole, male				
Setpoint <sup>4)</sup>		two setpoints (SP1, SP2)				
Relay contact	VDC / ADC	30 / ≤0.5				
Hysteresis	% F.S.	1				
Materials exposed to vacuum		Aluminum oxide ceramic (Al <sub>2</sub> O <sub>3</sub> ), Vacon 70 <sup>5)</sup> , stainless steel (AISI 316L <sup>6)</sup> , AgCuTi hard solder, sealing glass				

<sup>1)</sup> Non-linearity, hysteresis, repeatability at 25°C ambient operating temperature without temperature effects after 2 hours operation.

<sup>2)</sup> Increase 10 ... 90% F.S.

<sup>3)</sup> Non operation

<sup>4)</sup> CDG025D-S only

<sup>5)</sup> 28% Ni, 23% Co, 49% Fe

<sup>6)</sup> 18% Cr, 10% Ni, 3% Mo, 69% Fe

## CDG025D, CDG025D-S (continued)

**Specifications (Torr based other ranges)**

Measurement Range F.S. (Full Scale)	Torr Pa mbar	-	200	-	20	-	-	0.25	-
		110,000	26,664	10,000	2,666	1,000	100	33.3	10
		1000	267	100	26.7	10	1	0.33	0.1
Accuracy <sup>1)</sup>	% of reading	0.2	0.2	0.2	0.2	0.2	0.2	0.25	0.5
Temperature effect on zero	% F.S./°C	0.005	0.005	0.005	0.005	0.005	0.015	0.02	0.02
on span	% of reading/°C	0.01	0.01	0.01	0.01	0.01	0.01	0.03	0.03
Resolution	% F.S.	0.003	0.003	0.003	0.003	0.003	0.003	0.003	0.003
Pressure, max.	kPa (absolute)	400	260	260	260	260	260	130	130
Response time <sup>2)</sup>	ms	30	30	30	30	30	30	130	130

<sup>1)</sup> Non-linearity, hysteresis, repeatability at 25°C ambient operating temperature without temperature effects after 2 hours operation.

<sup>2)</sup> Increase 10 ... 90% F.S.

For further specifications, see table above.

**Dimensions, Internal Volume, Weight**

mm (inch)

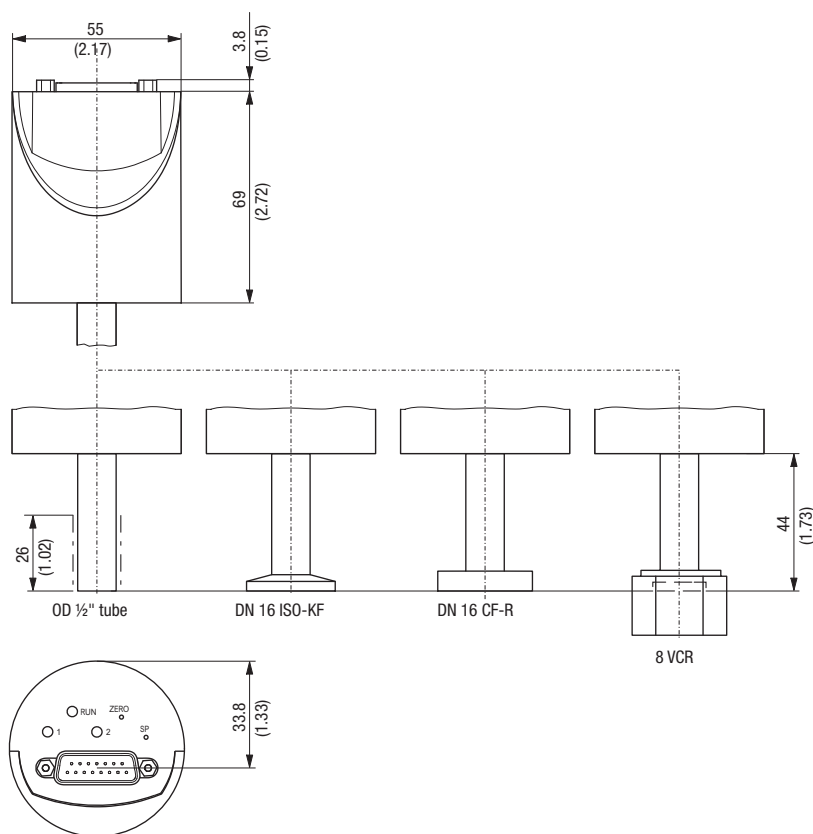

		1/2" tube	DN 16 ISO KF	DN 16 CF-R	8 VCR®
Internal volume	cm <sup>3</sup> (inch <sup>3</sup> )	3.6 (0.22)	3.6 (0.22)	3.6 (0.22)	3.6 (0.22)
Weight	g	310	330	350	370

# SKY® Capacitance Diaphragm Gauge

## CDG025D-X3

The INFICON SKY CDG025D Capacitance Diaphragm Gauge line of highly accurate temperature compensated manometers is designed for stable performance in harsh manufacturing tool environments. Advanced digital electronics improve gauge performance and offer easy handling features such as one pushbutton zero function and setpoint adjustment. The corrosion resistant ultra pure ceramic sensor provides excellent zero stability with a long life expectancy of several million pressure cycles, including atmospheric bursts. A unique sensor shielding (patent pending) protects the gauge from process contamination. A robust mechanical design and digital electronics improve EMC compatibility, long term stability and temperature compensation. The CDG025D sets new standards for fast stability after power on and fast recovery from atmospheric pressure exposure..



### Advantages

- Full scale ranges from 100 mTorr ... 1000 Torr
- Fast stability after power on
- Fast recovery from atmospheric pressure
- Corrosion resistant ceramic sensor
- Excellent long term signal stability
- Temperature compensated
- Sensor double protected from contamination
- One pushbutton zero function
- Wide range power supply
- 2 setpoints
- RS232 interface
- Clean room compliant

### Applications

Accurate and fast pressure measurement for demanding applications:

- Semiconductor manufacturing equipment for Etch, CVD, PVD, ALD
- Data storage and display manufacturing equipment
- Industrial vacuum equipment
- General high accuracy pressure measurement

# CDG025D-X3 (continued)

## Ordering Information

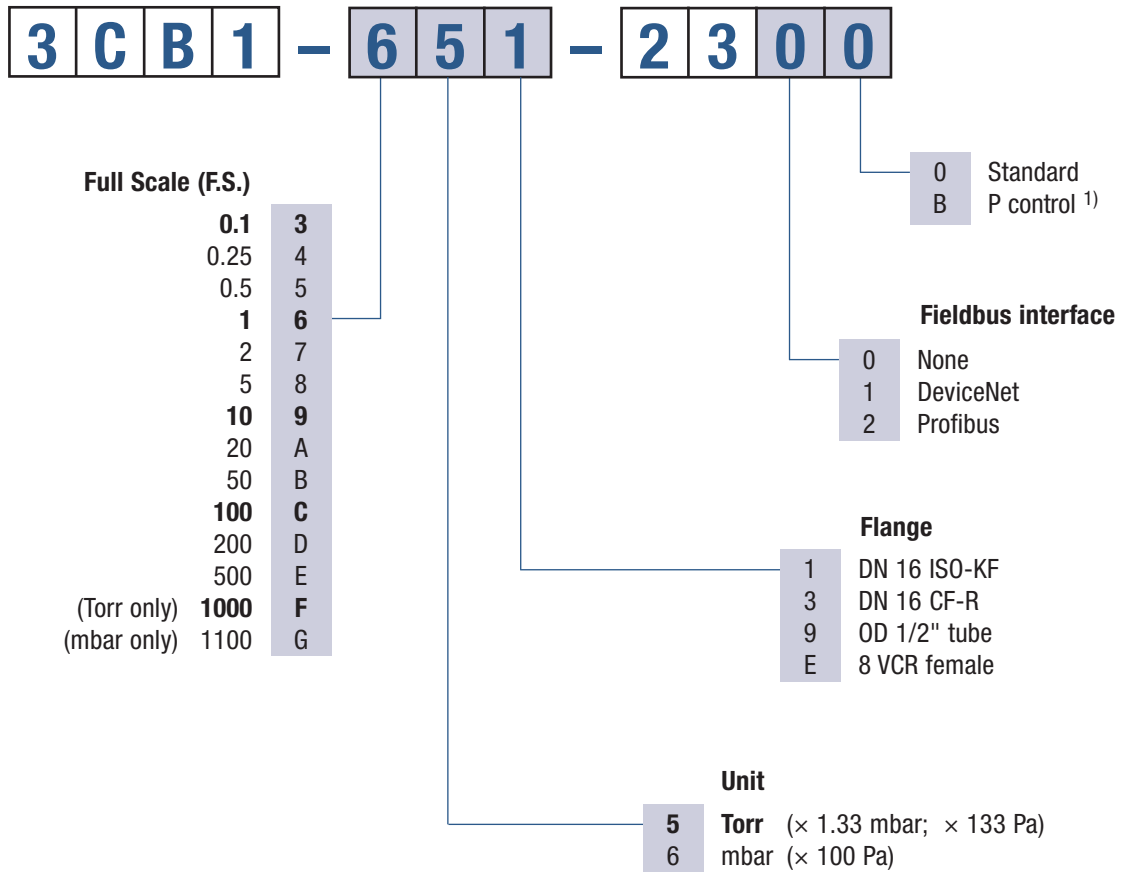

<sup>1)</sup> Optimised signal filter setting for pressure control.

**bold** = standard products

Other flange types and full scale ranges (F.S.) on request.

**CDG025D-X3** (continued)

**Specifications (Torr based standard products)**

Measurement Range F.S. (Full Scale)	Torr Pa mbar	1000 133,322 1333	100 13,332 133	10 1,333 13.3	1 133 1.3	0.1 13 0.13
Accuracy <sup>1)</sup>	% of reading	0.2	0.2	0.2	0.2	0.5
Temperature effect on zero	% F.S./°C	0.005	0.005	0.005	0.015	0.02
on span	% of reading/°C	0.01	0.01	0.01	0.01	0.03
Resolution	% F.S.	0.003	0.003	0.003	0.003	0.003
<b>Pressure, max.</b>	<b>kPa (absolute)</b>	<b>400</b>	<b>260</b>	<b>260</b>	<b>260</b>	<b>130</b>
Response time <sup>2)</sup>	ms	30	30	30	30	130 / 30
Lowest reading	% F.S.	0.01				
Lowest suggested reading	% F.S.	0.05				
Lowest suggested control pressure	% F.S.	0.5				
Temperature Operation (ambient)	°C	+5 ... +50				
Bakeout at flange <sup>4)</sup>	°C	≤110				
Storage	°C	-40 ... +65				
Supply voltage	VDC	+14 ... +30				
Power consumption	W	≤1				
Output signal (analog)	VDC	0 ... +10				
Degree of protection		IP 30				
Standards		EN 61000-6-2, EN 61000-6-3, EN 61010, UL 61010-1, CSA 22.2 No.61010-1, RoHS				
Electrical connection		D-sub, 15 pole, male				
Setpoint		two setpoints (SP1, SP2)				
Relay contact	VDC / ADC	30 / ≤0.5				
Hysteresis	% F.S.	1				
Materials exposed to vacuum		Aluminum oxide ceramic (Al <sub>2</sub> O <sub>3</sub> ), stainless steel (AISI 316L <sup>5)</sup> )				

<sup>1)</sup> Non-linearity, hysteresis, repeatability at 25°C ambient operating temperature without temperature effects after 2 hours operation.

<sup>2)</sup> Increase 10 ... 90% F.S.

<sup>3)</sup> For pressure control type only

<sup>4)</sup> Non operation

<sup>5)</sup> 18% Cr, 10% Ni, 3% Mo, 69% Fe

**CDG025D-X3** (continued)

**Specifications (Torr based other ranges)**

Measurement Range F.S. (Full Scale)	Torr Pa mbar	-	200	-	20	-	-	0.25	-
		110,000 1100	26,664 267	10,000 100	2,666 26.7	1,000 10	100 1	33.3 0.33	10 0.1
Accuracy <sup>1)</sup>	% of reading	0.2	0.2	0.2	0.2	0.2	0.2	0.25	0.5
Temperature effect on zero	% F.S./°C	0.005	0.005	0.005	0.005	0.005	0.015	0.02	0.02
on span	% of reading/°C	0.01	0.01	0.01	0.01	0.01	0.01	0.03	0.03
Pressure, max.	kPa (absolute)	236	260	260	260	260	260	130	130
Resolution	% F.S.	0.003	0.003	0.003	0.003	0.003	0.003	0.003	0.003
Response time <sup>2)</sup>	ms	30	30	30	30	30	30	130	130 / 30 <sup>3)</sup>

<sup>1)</sup> Non-linearity, hysteresis, repeatability at 25°C ambient operating temperature without temperature effects after 2 hours operation.

<sup>2)</sup> Increase 10 ... 90% F.S.

<sup>3)</sup> For pressure control type only

Further specifications see table above.

**Dimensions, Internal Volume, Weight**

mm (inch)

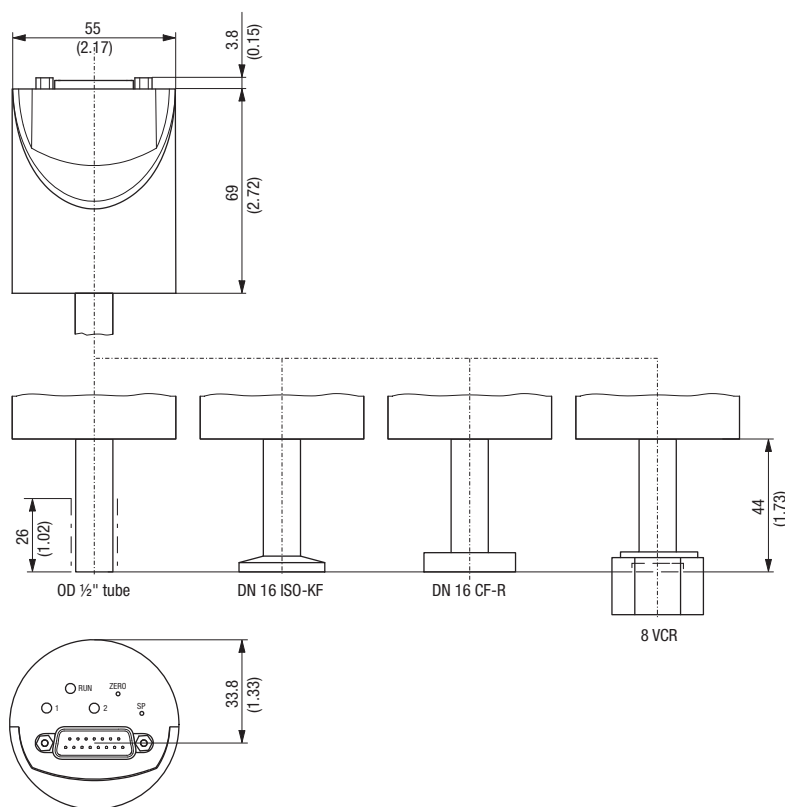

		1/2" tube	DN 16 ISO KF	DN 16 CF-R	8 VCR®
Internal volume	cm <sup>3</sup> (inch <sup>3</sup> )	3.6 (0.22)	3.6 (0.22)	3.6 (0.22)	3.6 (0.22)
Weight	g	310	330	350	370



# SKY® Capacitance Diaphragm Gauge

## CDG045D

INFICON SKY CDG045D manometers are your best choice for highly accurate total pressure measurement and control. CDG045D gauges are temperature controlled at 45°C for superior signal stability and repeatability. They are available for full scale ranges from 100 mTorr to 1000 Torr, with all common flange types and fieldbus interfaces and provide a linear 0 to 10 V, gas type independent, pressure signal. INFICON capacitance manometers use a corrosion proof ultra pure alumina ceramic diaphragm. The advantages of the ceramic sensor are better signal stability, faster recovery from atmosphere, short warm up time and an extraordinary lifetime. INFICON CDG are high quality, cost effective pressure sensors for demanding vacuum applications.



### Advantages

- Lower CoO (cost of ownership), 50% faster warm up, energy efficient low power consumption
- Easy integration, wide variety of full scales, flanges and interfaces, standard with two set points
- Easy one push button or remote signal zero command, zero offset adjustable
- Diagnostic port for quick service and maintenance
- Two year warranty, longer lifetime with advanced heating concept and gauge protection
- No long term recalibration due to excellent signal stability and repeatability, even in harsh plasma applications
- Compliance & standards: CE, EN, UL, SEMI, RoHS

### Applications

- Etch, CVD, PVD and other semiconductor production processes
- Chemical and corrosive vacuum processes
- General thin film and vacuum processes
- Reference sensor for monitoring of test instruments according to international standards
- Transfer standard for traceability measurements

# CDG045 (continued)

## Ordering Information

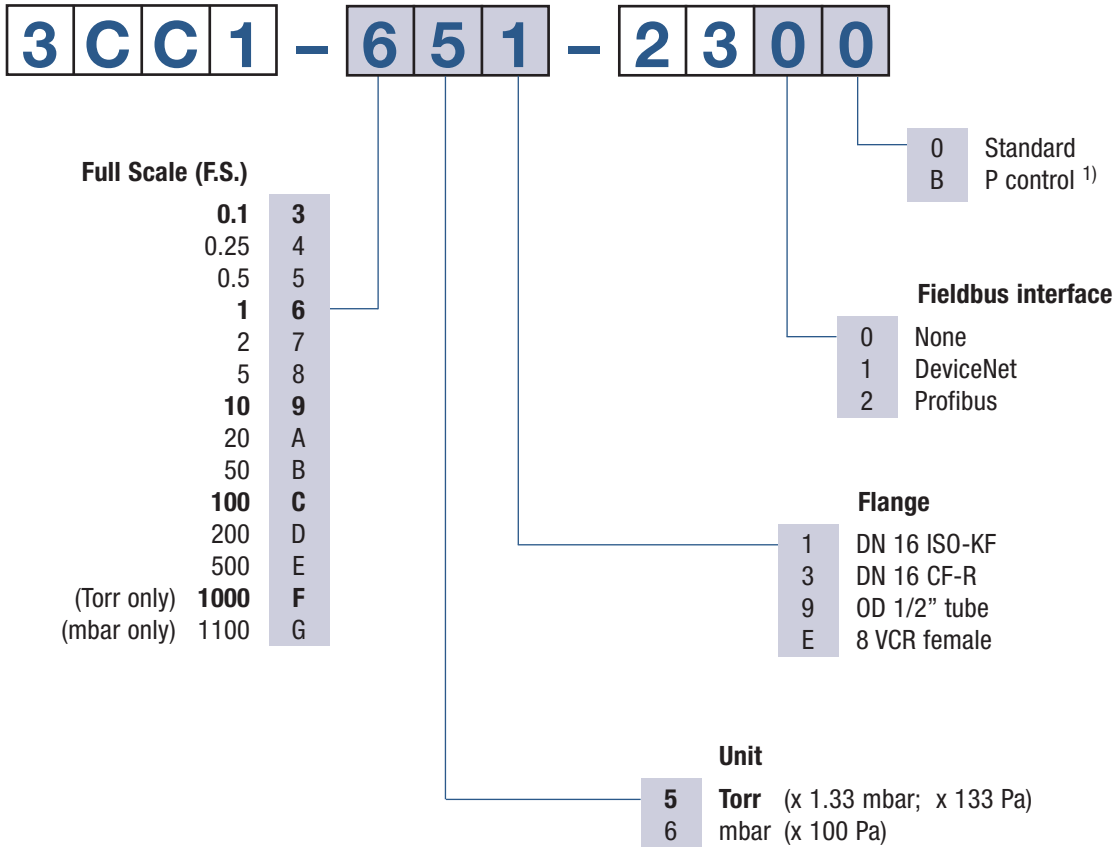

<sup>1)</sup> Optimised signal filter setting for pressure control

**bold** = standard products

Other flange types and full scale ranges (F.S.) on request.

## Accessories

	<b>Diagnostic</b>
Communication adapter (2 m) for PC RS232 serial port	<b>303-333</b>

Software to run the diagnostic functions on Windows NT, XP can be downloaded from our website.

**CDG045** (continued)

**Specifications** (Torr based standard products)

Measurement Range F.S. (Full Scale)	Torr Pa mbar	1000 133,322 1333	100 13,332 133	10 1,333 13.3	1 133 1.3	0.1 13 0.13
Accuracy <sup>1)</sup>	% of reading	0.15				
Temperature effect on zero	% F.S./°C	0.0025				0.005
on span	% of reading/°C	0.01				
Pressure, max.	kPa (absolute)	400	260			130
Resolution	% F.S.	0.003				
Lowest reading	% F.S.	0.01				
Lowest suggested reading	% F.S.	0.05				
Lowest suggested control pressure	% F.S.	0.5				
Temperature Operation (ambient)	°C	+10 ... +40				
Bakeout at flange	°C	≤110				
Storage	°C	-40 ... +65				
Supply voltage	+14 ... +30 VDC or ±15 V (±5%)					
Power consumption During Heat up	W	≤12				
At operating temperature	W	≤8				
Output signal (analog)	VDC	0 ... +10				
Response time <sup>2)</sup>	ms	30				130 / 30 <sup>3)</sup>
Degree of protection	IP 40					
Standards	EN 61000-6-3, EN 61010, UL 61010-1, CSA 22.2 No.61010-1, SEMI S-2					
Electrical connection	D-sub, 15 pole, male					
Setpoint	two setpoints (SP1, SP2)					
Relay contact	VDC / ADC	≤30 / ≤0.5				
Hysteresis	% F.S.	1				
Diagnostic port Protocol	RS232-C					
Read	pressure, status, ID,					
Set	set points, filter, zero adjust, factory reset, DC offset					
Materials exposed to vacuum	Aluminium oxide ceramic (Al <sub>2</sub> O <sub>3</sub> ), stainless steel (AISI 316L <sup>4)</sup> )					

<sup>1)</sup> Non-linearity, hysteresis, repeatability at 25°C ambient operating temperature without temperature effects after 2 hours operation

<sup>2)</sup> Increase 10 ... 90% F.S.

<sup>3)</sup> For pressure control type only

<sup>4)</sup> 18% Cr, 10% Ni, 3% Mo, 69% Fe

**CDG045** (continued)

**Specifications (Torr based other ranges)**

Measurement Range F.S. (Full Scale)	Torr Pa mbar	500	200	50	20	5	2	0.5	0.25	
		66,661 666.61	26,664 267	6,666.1 66.67	2,666 26.7	666.61 6.6661	266.66 2.67	66.66 0.67	33.3 0.33	
Accuracy <sup>1)</sup>	% of reading	0.15								
Temperature effect on zero	% F.S./°C	0.0025						0.005		
on span	% of reading/°C	0.01								
Pressure, max.	kPa (absolute)	400	260				130			
Response time <sup>2)</sup>	ms	30						130		

<sup>1)</sup> Non-linearity, hysteresis, repeatability at 25 °C ambient operating temperature without temperature effects after 2 hours operation.

<sup>2)</sup> Increase 10 ... 90% F.S.

Further specifications see table above.

**Specifications (mbar based products)**

Measurement Range F.S. (Full Scale)	mbar Pa	1100	100	10	1	0.1
		110,000	10,000	1,000	100	10
Accuracy <sup>1)</sup>	% of reading	0.15				
Temperature effect on zero	% F.S./°C	0.0025				0.005
on span	% of reading/°C	0.01				
Pressure, max.	kPa (absolute)	400	260			130
Response time <sup>2)</sup>	ms	30				130 / 30 <sup>3)</sup>

<sup>1)</sup> Non-linearity, hysteresis, repeatability at 25 °C ambient operating temperature without temperature effects after 2 hours operation.

<sup>2)</sup> Increase 10 ... 90% F.S.

<sup>3)</sup> For pressure control type only

Further specifications see tables «SPECIFICATIONS (Torr based standard products)» and «SPECIFICATIONS (Torr based other products)».

**Specifications (DeviceNet™)**
**CDG045D DeviceNet™**

Protocol	DeviceNet™, group 2 slave only		
Data rate	kBaud	125, 250, 500 by switch or network programmable	
Cable length			
125 kbps	m (ft)	500 (1650)	
250 kbps	m (ft)	250 (825)	
500 kbps	m (ft)	100 (330)	
MAC ID	address 00 - 63 by switch or network programmable		
Digital functions	read	pressure, status, ID	
	set	set points, filter, zero adjust, factory reset, DC offset	
Specification	DeviceNet™ "Vacuum Gauge Device Profile" (ODVA)		
Device type	"VG" vacuum gauge		
I / O slave messaging	polling only		
Supply voltage for gauge at D-sub connector	+14 ... +30 VDC or ±15 V / ≤12 W		
Supply voltage for DeviceNet transceiver at microstyle connector	24 V nom / <2 W (11 ... 25 V)		
Connector for DeviceNet™	microstyle, 5 pin, male		
Connector for CDG (analog output, supply voltage CDG, setpoints)	D-sub, 15 pin, male		

## CDG045 (continued)

### Specifications (Profibus DP)

		<b>CDG045D Profibus DP</b>
Baud rates	kBaud	9.6 / 19.2 / 93.75 / 187.5 / 500
	MBaud	1.5 / 12
Address		address 00 - 125 by switch or network programmable
Digital functions	read	pressure, status, ID
	set	set points, filter, zero adjust, factory reset, DC offset
Connector for Profibus DP		D-sub, 9 pin, female
Connector for CDG (analog output, supply voltage, setpoints)		D-sub, 15 pin, male

### Dimensions

mm (inch)

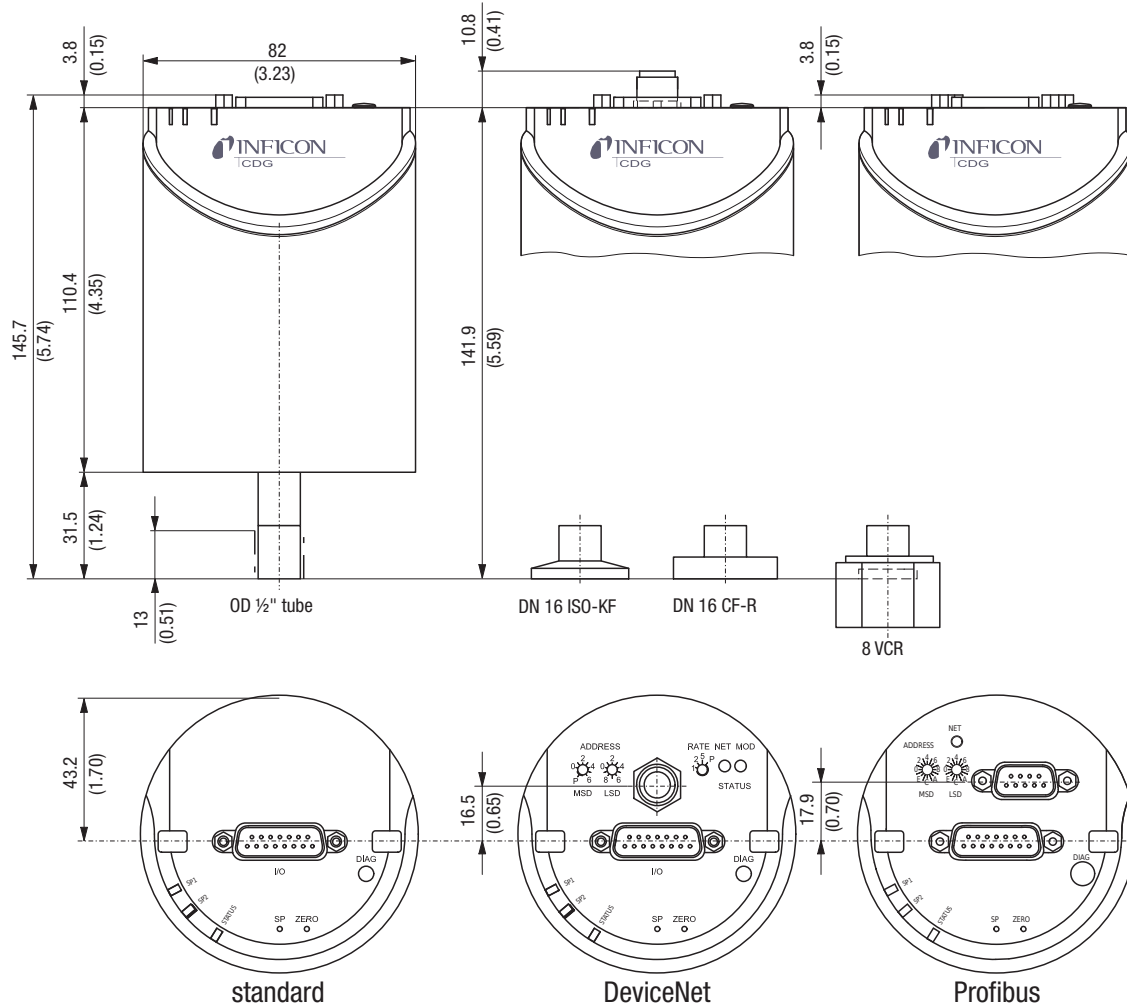

		<b>1/2" tube</b>	<b>DN 16 ISO KF</b>	<b>DN 16 CF-R</b>	<b>8 VCR®</b>
Internal volume	cm <sup>3</sup> (inch <sup>3</sup> )	4.2 (0.26)	4.2 (0.26)	4.2 (0.26)	4.2 (0.26)
Weight	g	837	852	875	897

# SKY® Capacitance Diaphragm Gauges

## CDG100D

INFICON SKY CDG100D manometers are your best choice for accurate total pressure measurement and control. CDG100D gauges are temperature controlled at 100°C for superior performance in demanding semiconductor and plasma processes. They are available for full scale ranges from 100 mTorr to 1000 Torr, with all common flange types and fieldbus interfaces and provide a linear 0 to 10 V, gas type independent, pressure signal. INFICON capacitance manometers use an ultra pure alumina ceramic diaphragm which is corrosion proof. The advantages of the ceramic sensor are better signal stability, faster recovery from atmosphere, short warm up time and an extraordinary lifetime. INFICON CDG are high quality, cost effective pressure sensors for demanding semiconductor, plasma and vacuum applications.



### Advantages

- Lower CoO (cost of ownership), 50% faster warm up, energy efficient low power consumption
- Easy integration, wide variety of full scales, flanges and interfaces, standard with two set points
- Easy one push button or remote signal zero command, zero offset adjustable
- Diagnostic port for quick service and maintenance
- Two year warranty, longer lifetime with advanced heating concept and gauge protection
- No long term recalibration due to excellent signal stability and repeatability, even in harsh plasma applications
- Compliance & standards: CE, EN, UL, SEMI, RoHS

### Applications

- Etch, PVD, CVD and other semiconductor production processes
- Chemical and corrosive high temperature processes
- General thin film and vacuum processes requiring gauge protection

## CDG100D (continued)

### Ordering Information

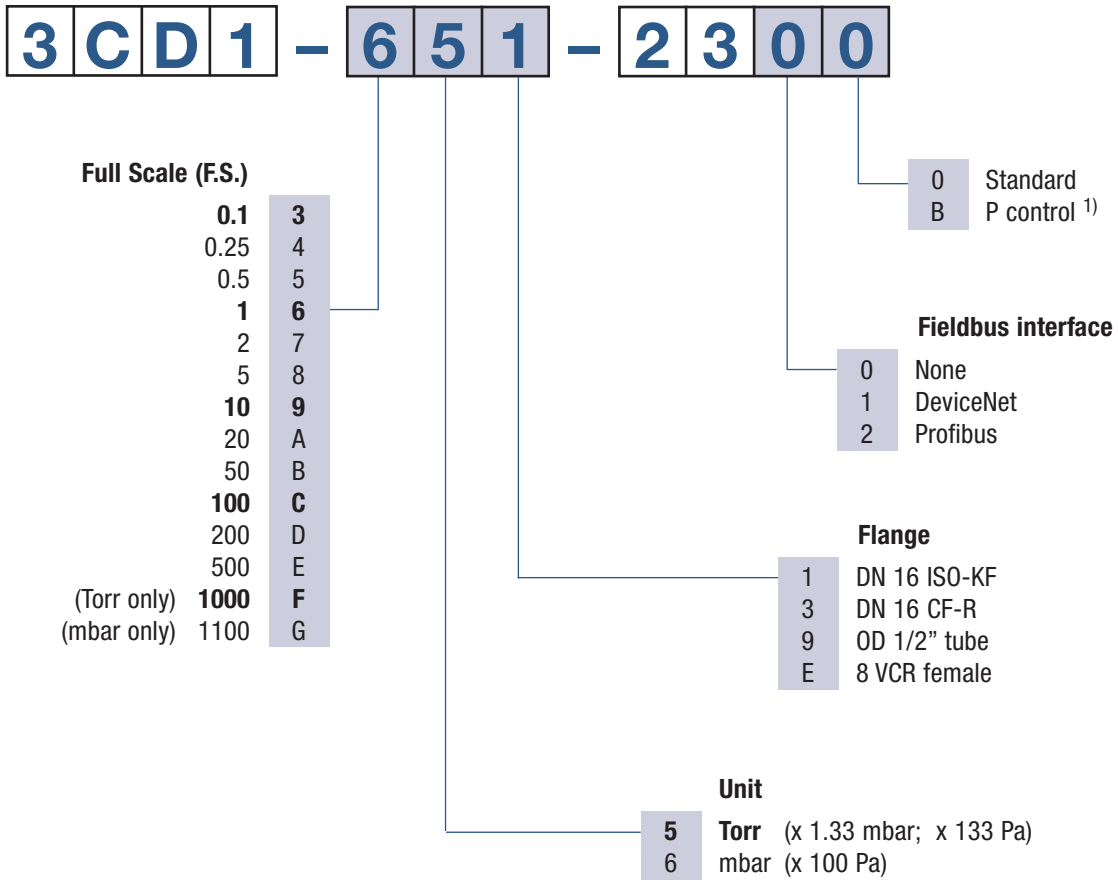

<sup>1)</sup> Optimised signal filter setting for pressure control

**bold** = standard products

Other flange types and full scale ranges (F.S.) on request.

### Accessories

Communication adapter (2 m) for PC RS232 serial port

### Diagnostic

**303-333**

Software to run the diagnostic functions on Windows NT, XP can be downloaded from our website.

**CDG100D** (continued)

**Specifications (Torr based standard products)**

Measurement Range F.S. (Full Scale)	Torr Pa mbar	1000 133,322 1333	100 13,332 133	10 1,333 13.3	1 133 1.3	0.1 13 0.13
Accuracy <sup>1)</sup>	% of reading	0.2				0.4
Temperature effect on zero	% F.S./°C	0.0025				0.005
on span	% of reading/°C	0.02				
Pressure, max.	kPa (absolute)	400		260		130
Resolution	% F.S.	0.003				
Lowest reading	% F.S.	0.01				
Lowest suggested reading	% F.S.	0.05				
Lowest suggested control pressure	% F.S.	0.5				
Temperature Operation (ambient)	°C	+10 ... +50				
Bakeout at flange	°C	≤110				
Storage	°C	-40 ... +65				
Supply voltage		+14 ... +30 VDC or ±15 V (±5%)				
Power consumption During Heat up	W	≤15				
At operating temperature	W	≤10				
Output signal (analog)	VDC	0 ... +10				
Response time <sup>2)</sup>	ms	30				130 / 30 <sup>3)</sup>
Degree of protection		IP 40				
Standards		EN 61000-6-3, EN 61010, UL 61010-1, CSA 22.2 No.61010-1, SEMI S-2				
Electrical connection		D-sub, 15 pole, male				
Setpoint		two setpoints (SP1, SP2)				
Relay contact	VDC / ADC	≤30 / ≤0.5				
Hysteresis	% F.S.	1				
Diagnostic port Protocol		RS232-C				
Read		pressure, status, ID,				
Set		set points, filter, zero adjust, factory reset, DC offset				
Materials exposed to vacuum		Aluminum oxide ceramic (Al <sub>2</sub> O <sub>3</sub> ), stainless steel (AISI 316L <sup>4)</sup> )				

1) Non-linearity, hysteresis, repeatability at 25°C ambient operating temperature without temperature effects after 2 hours operation.

2) Increase 10 ...

3) For pressure control type only

4) 18% Cr, 10% Ni, 3% Mo, 69% Fe



**CDG100D** (continued)

**Specifications (Torr based other ranges)**

Measurement Range F.S. (Full Scale)	Torr Pa mbar	500 66,661 666.61	200 26,664 267	50 6,666.1 66.67	20 2,666 26.7	5 666.61 6.6661	2 266.66 2.67	0.5 66.66 0.67	0.25 33.3 0.33
Accuracy <sup>1)</sup>	% of reading	0.2						0.4	
Temperature effect on zero	% F.S./°C	0.0025						0.005	
on span	% of reading/°C	0.02							
Pressure, max.	kPa (absolute)	400	260				130		
Response time <sup>2)</sup>	ms	30						130	

<sup>1)</sup> Non-linearity, hysteresis, repeatability at 25°C ambient operating temperature without temperature effects after 2 hours operation.

<sup>2)</sup> Increase 10 ... 90% F.S.

Further specifications see table above.

**Specifications (mbar based products)**

Measurement Range F.S. (Full Scale)	mbar Pa	1100 110,000	100 10,000	10 1,000	1 100	0.1 10	
Accuracy <sup>1)</sup>	% of reading	0.2				0.4	
Temperature effect on zero	% F.S./°C	0.0025				0.005	
on span	% of reading/°C	0.02					
Pressure, max.	kPa (absolute)	400	260			130	
Response time <sup>2)</sup>	ms	30				130 / 30 <sup>3)</sup>	

<sup>1)</sup> Non-linearity, hysteresis, repeatability at 25°C ambient operating temperature without temperature effects after 2 hours operation.

<sup>2)</sup> Increase 10 ... 90% F.S.

<sup>3)</sup> For pressure control type only

Further specifications see table «SPECIFICATIONS (Torr based standard products)».

**CDG100D** (continued)

**Specifications (DeviceNet™)**

			<b>CDG100D DeviceNet™</b>
Protocol			DeviceNet™, group 2 slave only
Data rate	kBaud		125, 250, 500 by switch or network programmable
Cable length			
125 kbps	m (ft)		500 (1650)
250 kbps	m (ft)		250 (825)
500 kbps	m (ft)		100 (330)
MAC ID			address 00 - 63 by switch or network programmable
Digital functions	read		pressure, status, ID
	set		set points, filter, zero adjust, factory reset, DC offset
Specification			DeviceNet™ "Vacuum Gauge Device Profile" (ODVA)
Device type			"VG" vacuum gauge
I / O slave messaging			polling only
Supply voltage for gauge at D-sub connector			+14 ... +30 VDC or ±15 V / ≤12 W
Supply voltage for DeviceNet transceiver at microstyle connector			24 V nom / <2 W (11 ... 25 V)
Connector for DeviceNet™			microstyle, 5 pin, male
Connector for CDG (analog output, supply voltage CDG, setpoints)			D-sub, 15 pin, male

**Specifications (Profibus DP)**

			<b>CDG100D Profibus DP</b>
Baud rates	kBaud		9.6 / 19.2 / 93.75 / 187.5 / 500
	MBaud		1.5 / 12
Address			address 00 - 125 by switch or network programmable
Digital functions	read		pressure, status, ID
	set		set points, filter, zero adjust, factory reset, DC offset
Connector for Profibus DP			D-sub, 9 pin, female
Connector for CDG (analog output, supply voltage, setpoints)			D-sub, 15 pin, male

# CDG100D (continued)

## Dimensions

mm (inch)

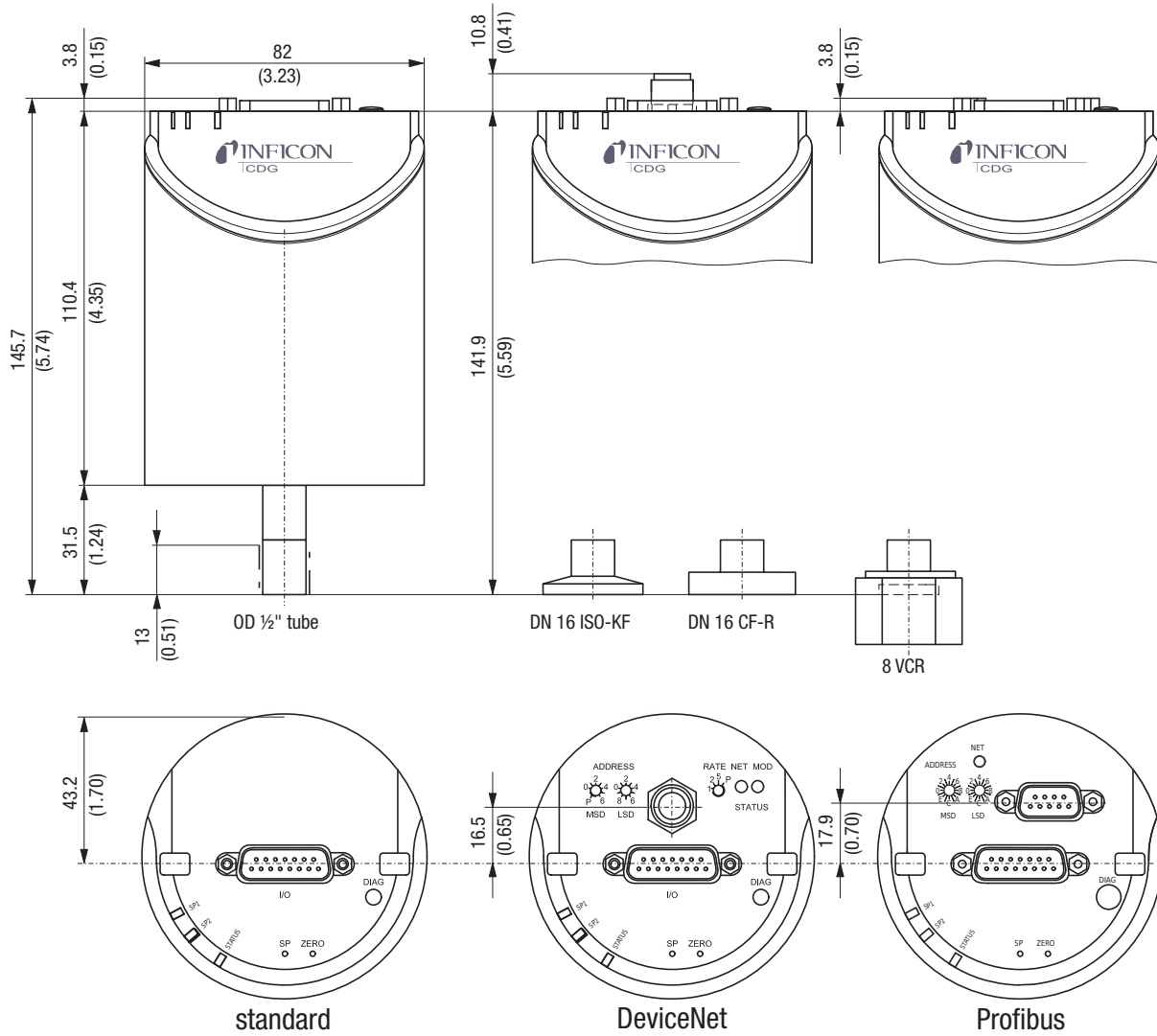

		1/2" tube	DN 16 ISO KF	DN 16 CF-R	8 VCR®
Internal volume	cm <sup>3</sup> (inch <sup>3</sup> )	4.2 (0.26)	4.2 (0.26)	4.2 (0.26)	4.2 (0.26)
Weight	g	837	852	875	897

# SKY® Capacitance Diaphragm Gauges

## CDG160D, CDG200D

INFICON SKY CDG160D and CDG200D high temperature manometers are your best choice for accurate total pressure measurement and control. CDG160D and CDG200D gauges are temperature controlled at 160°C respectively 200°C for superior performance in demanding semiconductor and plasma processes. They are available for full scale ranges from 1 Torr to 1000 Torr, with all common flange types and fieldbus interfaces and provide a linear 0 to 10V, gas type independent, pressure signal. INFICON capacitance manometers use an ultra pure alumina ceramic diaphragm which is corrosion proof. The advantages of the ceramic sensor are better signal stability, faster recovery from atmosphere, short warm up time and an extraordinary lifetime. INFICON CDG are high quality, cost effective pressure sensors for demanding semiconductor, plasma and vacuum applications.



**New!**  
200°C sensor

### Advantages

- Lower CoO (cost of ownership), 50% faster warm up, energy efficient low power consumption
- Easy integration, wide variety of full scales, flanges and interfaces, standard with two set points
- Easy one push button or remote signal zero command, zero offset adjustable
- Diagnostic port for quick service and maintenance
- Two year warranty, longer lifetime with  heating concept and gauge protection
- No long term recalibration due to excellent signal stability and repeatability, even in harsh plasma applications
- Compliance & standards: CE, EN, UL, SEMI, RoHS

### Applications

- Etch, PVD, CVD, LPCVD and other semiconductor production processes
- Chemical and corrosive high temperature processes
- General thin film and vacuum processes requiring gauge protection

## CDG160D, CDG200D (continued)

### Ordering Information

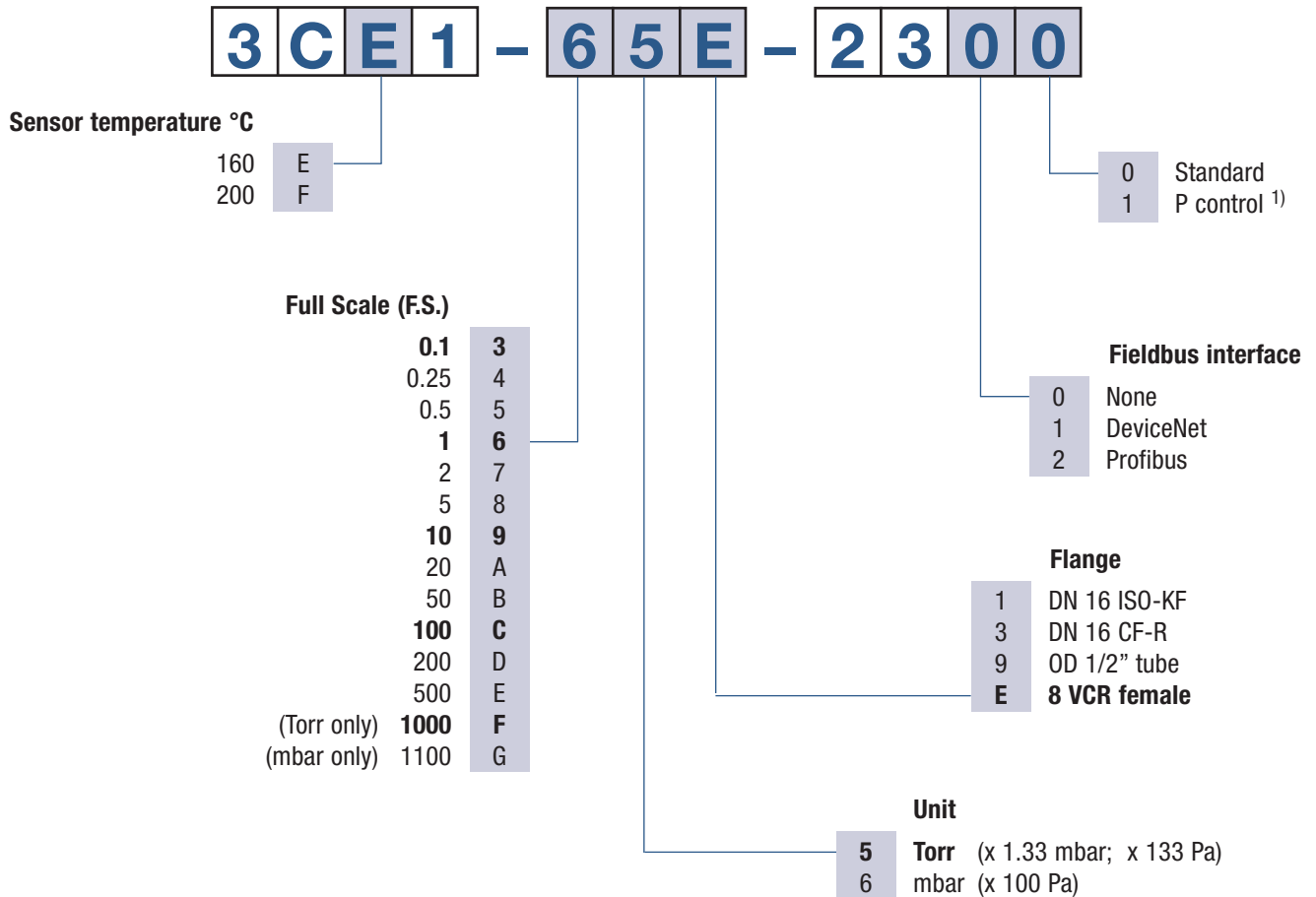

1) Optimised signal filter setting for pressure control

**bold** = standard products

Other flange types and full scale ranges (F.S.) on request.

### Accessories

	Diagnostic
Communication adapter (2 m) for PC RS232 serial port	303-333

Software to run the diagnostic functions on Windows NT, XP can be downloaded from our website.

**CDG160D, CDG200D** (continued)

**Specifications (Torr based standard products)**

Measurement Range F.S. (Full Scale)	Torr Pa mbar	1000 133,322 1333	100 13,332 133	10 1,333 13.3	1 133 1.3
Accuracy <sup>1)</sup>	% of reading	0.4			
Temperature effect					
on zero	% F.S./°C	0.005			
on span	% of reading/°C	0.02			
Pressure, max.	kPa (absolute)	400	260		
Resolution	% F.S.	0.003			
Lowest reading	% F.S.	0.01			
Lowest suggested reading	% F.S.	0.05			
Lowest suggested control pressure	% F.S.	0.5			
Temperature					
Operation (ambient)	°C	+10 ... +50			
Bakeout at flange	°C	≤200			
Storage	°C	-40 ... +65			
Supply voltage		+21 ... +30 VDC or ±15 V (±5%)			
Power consumption during heat up					
CDG160D	W	≤18			
CDG200D	W	≤25			
Power consumption at operating temperature					
CDG160D	W	≤12			
CDG200D	W	≤18			
Output signal (analog)	VDC	0 ... +10			
Response time <sup>2)</sup>	ms	30			
Degree of protection		IP 40			
Standards		EN 61000-6-3, EN 61010, UL 61010-1, CSA 22.2 No.61010-1, SEMI S-2			
Electrical connection		D-sub, 15 pole, male			
Setpoint		two setpoints (SP1, SP2)			
Relay contact	VDC / ADC	≤30 / ≤0.5			
Hysteresis	% F.S.	1			
Diagnostic port					
Protocol		RS232-C			
Read		pressure, status, ID,			
Set		set points, filter, zero adjust, factory reset, DC offset			
Materials exposed to vacuum		Aluminum oxide ceramic (Al <sub>2</sub> O <sub>3</sub> ), stainless steel (AISI 316L <sup>3)</sup> )			

1) Non-linearity, hysteresis, repeatability at 25°C ambient operating temperature without temperature effects after 2 hours operation.

2) Increase 10 ... 90% F.S.

3) 18% Cr, 10% Ni, 3% Mo, 69% Fe

**CDG160D, CDG200D** (continued)

**Specifications (Torr based other ranges)**

Measurement Range F.S. (Full Scale)	Torr Pa mbar	500 66,661 666.61	200 26,664 267	50 6,666.1 66.67	20 2,666 26.7	5 666.61 6.6661	2 266.66 2.67
Accuracy <sup>1)</sup>	% of reading	0.4					
Temperature effect on zero	% F.S./°C	0.005					
on span	% of reading/°C	0.02					
Pressure, max.	kPa (absolute)	400					260
Resolution	% F.S.	0.003					

<sup>1)</sup> Non-linearity, hysteresis, repeatability at 25°C ambient operating temperature without temperature effects after 2 hours operation.

Further specifications see table above.

**Specifications (mbar based products)**

Measurement Range F.S. (Full Scale)	mbar Pa	1100 110,000	100 10,000	10 1,000	1 100
Accuracy <sup>1)</sup>	% of reading	0.4			
Temperature effect on zero	% F.S./°C	0.005			
on span	% of reading/°C	0.02			
Pressure, max.	kPa (absolute)	400			260
Resolution	% F.S.	0.003			

<sup>1)</sup> Non-linearity, hysteresis, repeatability at 25°C ambient operating temperature without temperature effects after 2 hours operation.

Further specifications see table «SPECIFICATIONS (Torr based standard products)».

**Specifications (DeviceNet™)**

CDG160D, CDG200D DeviceNet™		
Protocol	DeviceNet™, group 2 slave only	
Data rate	kBaud	125, 250, 500 by switch or network programmable
Cable length		
125 kbps	m (ft)	500 (1650)
250 kbps	m (ft)	250 (825)
500 kbps	m (ft)	100 (330)
MAC ID	address 00 - 63 by switch or network programmable	
Digital functions	read	pressure, status, ID
	set	set points, filter, zero adjust, factory reset, DC offset
Specification	DeviceNet™ "Vacuum Gauge Device Profile" (ODVA)	
Device type	"VG" vacuum gauge	
I / O slave messaging	polling only	
Supply voltage for gauge at D-sub connector	+14 ... +30 VDC or ±15 V / ≤12 W	
Supply voltage for DeviceNet transceiver at microstyle connector	24 V nom / <2 W (11 ... 25 V)	
Connector for DeviceNet™	microstyle, 5 pin, male	
Connector for CDG (analog output, supply voltage CDG, setpoints)	D-sub, 15 pin, male	

## CDG160D, CDG200D (continued)

### Specifications (Profibus DP)

		<b>CDG160D, CDG200D Profibus DP</b>	
Baud rates	kBaud	9.6 / 19.2 / 93.75 / 187.5 / 500	
	MBaud	1.5 / 12	
Address		address 00 - 125 by switch or network programmable	
Digital functions	read	pressure, status, ID	
	set	set points, filter, zero adjust, factory reset, DC offset	
Connector for Profibus DP		D-sub, 9 pin, female	
Connector for CDG (analog output, supply voltage, setpoints)		D-sub, 15 pin, male	

### Dimensions, Internal Volume, Weight

mm (inch)

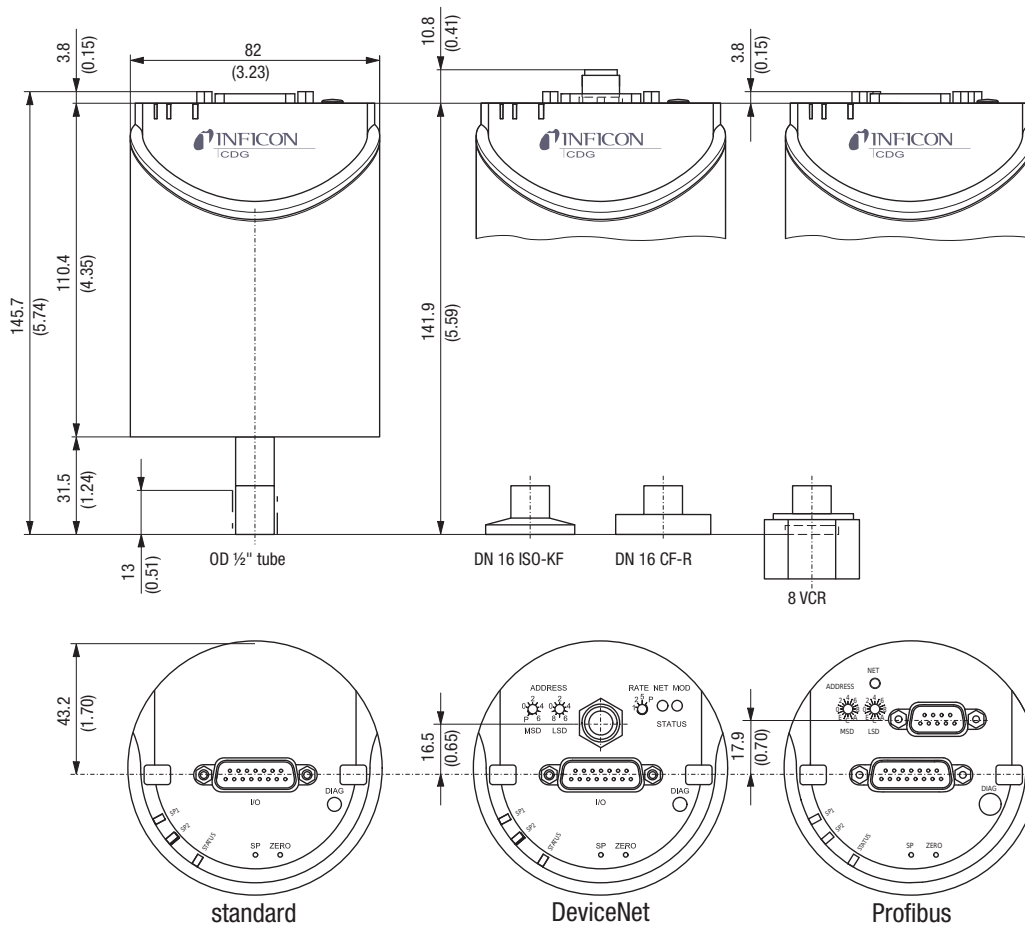

		<b>1/2" tube</b>	<b>DN 16 ISO KF</b>	<b>DN 16 CF-R</b>	<b>8 VCR®</b>
Internal volume	cm <sup>3</sup> (inch <sup>3</sup> )	4.2 (0.26)	4.2 (0.26)	4.2 (0.26)	4.2 (0.26)
Weight	g	837	852	875	897



# SKY® Capacitance Diaphragm Gauges

## AllCeramic™ CDG025-C

All vacuum exposed surfaces of the Sky AllCeramic CDG are constructed of ultra-pure aluminum oxide ceramic, replacing the stainless steel tubing of our traditional CDG. This product is preferred in applications where metal contamination must be avoided.



### Advantages

- No metal contamination
- Marginal zero drift
- Virtually corrosion proof – long sensor life results in reduced downtime thus reducing cost of ownership
- Superior accuracy and repeatability over long period of operation
- Better long term and temperature stability
- Less sensitive to frequent pressure cycles to atmosphere, may eliminate isolation valve (depending on operation mode)
- Less susceptible to particles and process by-products due to protection shield (Suprashield)

### Applications

- Etch, CVD and PVD processes
- Doping silicon using implantation or diffusion processes
- Oxidation
- Creation of gate oxide layer in the range of 100 Å
- Creation of barrier layers (Ti, TiN, Ta and TaN as a protection layer between Silicon and Aluminum or Copper)

### Ordering Information

Type	Flange	Full scale (Pa <sup>1)</sup> )				
		133322	13332.2	1333.22	133.322	ATM±13332.2 <sup>2)</sup>
CDG025-C	1/2" tube	371-250	371-251	371-252	371-253	371-200

<sup>1)</sup> Other pressure units on request

<sup>2)</sup> Pressure difference between atmospheric and gauge pressure

## AllCeramic CDG025-C (continued)

### Specifications

Measurement Range F.S. (full scale)	Pa	133322	13332.2	1333.22	133.322	ATM±13332.2	
Lowest suggested control pressure	Pa	$6.66 \times 10^{+2}$	$6.66 \times 10^{+1}$	$6.66 \times 10^{+0}$	$6.66 \times 10^{-1}$	–	
Lowest suggested reading	Pa	$6.66 \times 10^{+1}$	$6.66 \times 10^{+0}$	$6.66 \times 10^{-1}$	$6.66 \times 10^{-2}$	–	
Lowest reading	Pa	$1.33 \times 10^{+1}$	$1.33 \times 10^{+0}$	$1.33 \times 10^{-1}$	$1.33 \times 10^{-2}$	–	
Accuracy <sup>1)</sup>	% of reading	0.2	0.2	0.2	0.2	0.2	
Temperature effect on zero	% F.S./°C	0.005	0.005	0.005	0.015	0.05	
	% of reading/°C	0.01	0.01	0.01	0.01	0.04	
Resolution	% F.S.	0.0015	0.0015	0.0015	0.0025	0.01	
Temperature Operation (ambient)	°C	+5 ... +50	+5 ... +50	+5 ... +50	+5 ... +50	+5 ... +50	
	At flange	≤110	≤110	≤110	≤110	≤110	
	Storage	°C	–40 ... +65	–40 ... +65	–40 ... +65	–40 ... +65	–40 ... +65
Pressure max. (absolute)	kPa	400	267	267	267	267	
Power supply	Voltage 1	VDC	±15 ±5%	±15 ±5%	±15 ±5%	±15 ±5%	
	Voltage 2 or	VDC	+18 ... +26.4	+18 ... +26.4	+18 ... +26.4	+18 ... +26.4	
	Power consumption <sup>2)</sup>	W	≤1.6	≤1.6	≤1.6	≤1.6	
Output signal (analog)	Measuring range	V	0 ... +10	0 ... +10	0 ... +10	0 ... +10	+5±5
	Voltage range	V	–11 ... +11	–11 ... +11	–11 ... +11	–11 ... +11	–11 ... +11
	Relation voltage vs. pressure		linear	linear	linear	linear	linear
Response time	ms	30	30	30	100	30	
Internal volume	cm <sup>3</sup> (inch <sup>3</sup> )	4.5 (0.275)	4.5 (0.275)	4.5 (0.275)	4.5 (0.275)	4.5 (0.275)	
Weight	g	250	250	250	250	250	
Protective type		IP 30	IP 30	IP 30	IP 30	IP 30	
Electrical connection		D-sub, 15 pole, male	D-sub, 15 pole, male	D-sub, 15 pole, male	D-sub, 15 pole, male	D-sub, 15 pole, male	

Materials exposed to vacuum

Aluminum oxide ceramic (Al<sub>2</sub>O<sub>3</sub>), sealing glass

<sup>1)</sup> Non-linearity, hysteresis, repeatability at 25°C ambient operating temperature without temperature effects after 2 hours operation.

<sup>2)</sup> Typical value at 25°C ambient temperature after reaching operating temperature.

### Dimensions

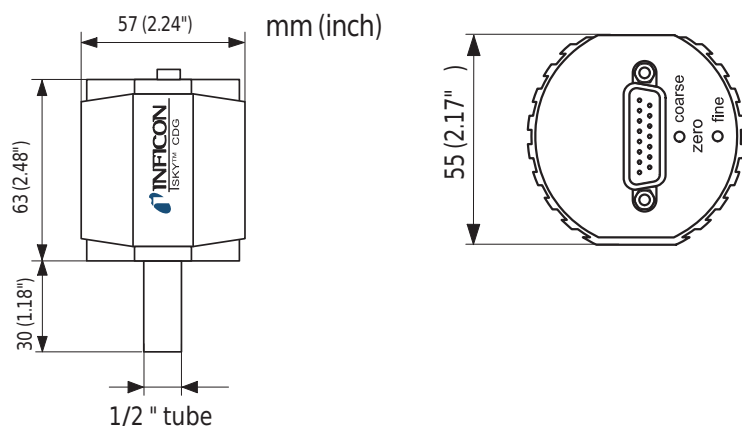

# SKY® Capacitance Diaphragm Gauges

## AllCeramic™ CDG160A-C / CDG160A-CS

The INFICON SKY AllCeramic CDG160A-C is the only completely metal-free 160°C temperature controlled capacitance diaphragm gauge designed for demanding applications, such as oxidation, diffusion and LPCVD. All surfaces exposed to the vacuum such as tubing, plasma shield and contamination protection shield are composed of corrosion-resistant ultra pure aluminum oxide ceramic, eliminating potential metal contamination from the gauge.

The INFICON SKY AllCeramic CDG160A-C integrates the proven sensor technology of the INFICON CDG160A series of gauges for reliable and repeatable performance in LPCVD and other harsh semiconductor manufacturing applications.



### Advantages

- Metal-free ultra pure ceramic design prevents metal contaminations
- Temperature controlled to 160°C prevents condensation of process products and by-products
- Compact design saves valuable space and simplifies tool integration
- High ambient temperature compatibility
- Enhanced particle protection chamber with an additional protection shield (Suprashield) reduces the probability of gauge contamination
- Unique ceramic sensor design provides repeatability and accurate measurements with excellent long-term stability
- Optional set point and status indication provides additional control and safety functions

### Applications

- Oxidation, diffusion and LPCVD processes
- Other metal-free vacuum measurement requirements

### Ordering Information

Type	Set point	Flange	Full scale (Pa <sup>1)</sup> )			
			133322	13332.2	1333.22	133.322
CDG160A-C	none	1/2" tube	371-260	371-261	371-262	371-263
CDG160A-CS	2	1/2" tube	371-270	371-271	371-272	371-273

<sup>1)</sup> Other pressure units on request

## CDG160A-C / CDG160A-CS (continued)

### Specifications

Measurement Range F.S. (full scale)	Pa	133322	13332.2	1333.22	133.322
Lowest suggested control pressure	Pa	$6.66 \times 10^{+2}$	$6.66 \times 10^{+1}$	$6.66 \times 10^{+0}$	$6.66 \times 10^{-1}$
Lowest suggested reading	Pa	$6.66 \times 10^{+1}$	$6.66 \times 10^{+0}$	$6.66 \times 10^{-1}$	$6.66 \times 10^{-2}$
Lowest reading	Pa	$1.33 \times 10^{+1}$	$1.33 \times 10^{+0}$	$1.33 \times 10^{-1}$	$1.33 \times 10^{-2}$
Accuracy <sup>1)</sup>	% of reading	0.5	0.5	0.5	0.5
Temperature effect on zero	% F.S./°C	0.005	0.005	0.005	0.005
on span	% of reading/°C	0.02	0.02	0.02	0.02
Resolution	% F.S.	0.005	0.005	0.005	0.005
Temperature Operation (ambient)	°C	+15 ... +55	+15 ... +55	+15 ... +55	+15 ... +55
Bakeout (at flange)	°C	≤160	≤160	≤160	≤160
Storage	°C	-40 ... +65	-40 ... +65	-40 ... +65	-40 ... +65
Pressure max. (absolute)	kPa	400	267	267	267
Power supply	VDC	±15 ±5%	±15 ±5%	±15 ±5%	±15 ±5%
Power consumption at operating temperature	W	≤15	≤15	≤15	≤15
during warm up					
CDG160A-C	W	≤24	≤24	≤24	≤24
CDG160A-CS	W	≤27	≤27	≤27	≤27
Output signal (analog) Measuring range	V	0 ... +10	0 ... +10	0 ... +10	0 ... +10
Voltage range	V	-11 ... +11	-11 ... +11	-11 ... +11	-11 ... +11
Relation voltage vs. pressure		linear	linear	linear	linear
Response time	ms	50	50	50	50
Protective type		IP 30	IP 30	IP 30	IP 30
Electrical connection CDG160A-C		D-sub, 15 pole, male	D-sub, 15 pole, male	D-sub, 15 pole, male	D-sub, 15 pole, male
CDG160A-CS		D-sub, 25 pole, male	D-sub, 25 pole, male	D-sub, 25 pole, male	D-sub, 25 pole, male
Internal volume	cm <sup>3</sup> (inch <sup>3</sup> )	4.7 (0.286)	4.7 (0.286)	4.7 (0.286)	4.7 (0.286)
Weight CDG160A-C	g	460	460	460	460
CDG160A-CS	g	490	490	490	490
Materials exposed to vacuum	Aluminum oxide ceramic (Al <sub>2</sub> O <sub>3</sub> ), sealing glass				

### CDG160A-CS

Relay functions	two set points, five status indicators (two setpoints active, temperature sensor ok, temperature ready, overheat) and optical status indicator (power on)				
Relays type of contact		NO / NC change over	NO / NC change over	NO / NC change over	NO / NC change over
Switching voltage max.	VDC / VAC	110 / 125	110 / 125	110 / 125	110 / 125
Switching current	A	1	1	1	1

<sup>1)</sup> Non-linearity, hysteresis, repeatability at 25°C ambient operating temperature without temperature effects after 2 hours operation.

## CDG160A-C / CDG160A-CS (continued)

### Dimensions

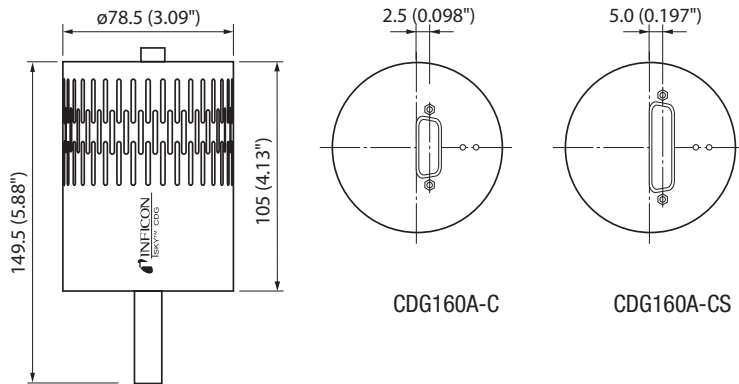

Ceramic tube 1/2"  
CDG160A-C and CDG160A-CS

# Bayard-Alpert Pirani Gauge

## BPG400

The INFICON Bayard-Alpert Pirani Combination Gauge, BPG400, functions as two gauges in a single compact unit measuring from  $5 \times 10^{-10}$  mbar to atmosphere ( $3.8 \times 10^{-10}$  Torr to atmosphere). Combining technologies reduces the complexity of installation, setup, and integration. Choose the BPG400 for affordable and repeatable process to base pressure measurements in one economic package.

### ADVANTAGES

- Extremely wide measurement range from  $5 \times 10^{-10}$  mbar to atmosphere ( $3.8 \times 10^{-10}$  Torr to atmosphere)
- Excellent repeatability in the process pressure range from  $10^{-8}$  ...  $10^{-2}$  mbar of 5%
- The Pirani interlock protects the Bayard-Alpert system from premature filament burnout and excess contamination from high pressure operation
- Long-life yttrium oxide coated iridium filament
- Optional graphic display and Fieldbus interfaces available
- Automatic high vacuum Pirani adjustment reduces operator interventions



### APPLICATIONS

- Pressure measurement in semiconductor process and transfer chambers
- Industrial coating
- General vacuum measurement and control in the low to ultra high vacuum range

### Ordering Information

Type	BPG400 without LCD display	BPG400 with LCD display	BPG400-SP with Profibus DP	BPG400-SD with DeviceNet™	BPG400-SR with RS485
DN 25 ISO-KF	353-500	353-501	353-505	353-507	353-509
DN 40 CF-R	353-502	353-503	353-506	353-508	353-513
Replacement sensor 25 ISO-KF	354-490	354-490	354-490	354-490	354-490
Replacement sensor 40 CF-R	354-491	354-491	354-491	354-491	354-491

### ACCESSORIES

Power supply 24 V DC / RS232C line	353-511
Bakeout extension, 100 mm (3.94 inch)	353-510
Baffle	353-512

**BPG400** (continued)

**Specifications**

		<b>BPG400 Standard</b>	<b>BPG400 Display</b>
Measurement range	(air, O <sub>2</sub> , CO, N <sub>2</sub> )	mbar (Torr)	5 x 10 <sup>-10</sup> ... 1000 (3.8 x 10 <sup>-10</sup> ... 750)
Accuracy	10 <sup>-8</sup> ... 10 <sup>-2</sup> mbar	% of reading	±15
Repeatability	10 <sup>-8</sup> ... 10 <sup>-2</sup> mbar	% of reading	5
Degas <sup>1)</sup>	p < 7.2 x 10 <sup>-6</sup>	mbar	electron bombardment, max. 3 min
Pressure, max.		bar (absolute)	2
<b>Temperature</b>			
Operation (ambient)		°C	0 ... +50
Storage		°C	-20 ... +70
<b>Bakeout</b>			
At flange with extension		°C	150
At flange without extension		°C	80
Electronics removed		°C	150
Supply voltage		V / A DC	20 ... 28 / 0.8
Output signal analog		V	0 ... +10
Measurement range		V	0.774 ... 10
Voltage vs. pressure		V / Decade	0.75
Error signal		V	0.3 / 0.5
Load impedance, min.		kΩ	10
Interface (digital) <sup>2)</sup>			RS232C
Electrical connection			D-sub, 15 pin, male
Cable length, max. <sup>3)</sup>		m (ft)	100 (330)
Materials exposed to vacuum			Yt <sub>2</sub> O <sub>3</sub> , Ir, Pt, Mo, Cu, W, NiFe, NiCr, stainless steel, glass
Internal volume KF / CF		cm <sup>3</sup> (inch) <sup>3</sup>	24 (1.46) / 34 (2.1)
Weight KF / CF		g	285 / 550
Protection type			IP30

<sup>1)</sup> Reduced accuracy during degas

<sup>2)</sup> Simultaneous use of RS232C or VGC400 series controllers and Fieldbus is not allowed

<sup>3)</sup> For RS232C operation <30 m

**Specifications**

		<b>BPG400-SP Profibus DP</b>
Baud rates	kBaud	9.6 / 19.2 / 93.75 / 187.5 / 500
	MBaud	1.5 / 12
Address		2 switches (address 00 - 127) or network programmable
Digital functions		read pressure, select units: Torr, mbar, Pa degas function, Pirani full scale adjust monitor gauge status safe state allows definition of behavior in case of error detailed alarm and warning information
Analog functions		0 ... 10 V analog output pressure indication two setpoint relays A + B
Setpoint relays		2
Range	mbar	1 x 10 <sup>-9</sup> ... 100
Relay contact		n.o., potential free
Hysteresis	% of reading	10
Contact rating	V / A DC	60 / 0.5
Connector for Profibus DP		D-sub, 9 pin, female
Connector for BPG (analog output, supply voltage, setpoints)		D-sub, 15 pin, male

## BPG400 (continued)

### Specifications

		<b>BPG400-SD DeviceNet™</b>
Protocol		DeviceNet™, group 2 slave only
Data rate switch	kBaud	125, 250, 500 or network programmable
Cable length		
125 kbps	m (ft)	500 (1650)
250 kbps	m (ft)	250 (825)
500 kbps	m (ft)	100 (330)
MAC ID		2 switches (address 00 - 63) or network programmable
Digital functions		read pressure, select units: Torr, mbar, Pa degas function, Pirani full scale adjust monitor gauge status safe state allows definition of behavior in case of error detailed alarm and warning information
Analog functions		0 ... 10 V analog output pressure indication two setpoint relays A + B
Specification		DeviceNet™ "Vacuum Gauge Device Profile"
Device type		"CG" for combination gauge
I / O slave messaging		polling only
Setpoint relays		2
Range	mbar	$1 \times 10^{-9}$ ... 100
Relay contact		n.o., potential free
Hysteresis	% of reading	10
Contact rating	V / A DC	60 / 0.5
Supply voltage for DeviceNet™	V / A DC	11 ... 25 / 0.5
Supply voltage for gauge	V / A DC	20 ... 28 / 0.8
Connector for DeviceNet™		microstyle, 5 pin
Connector for BPG (analog output, supply voltage, setpoints)		D-sub, 15 pin, male

### Specifications

		<b>BPG400-SR RS485</b>
Baud rates	kBaud	0.3 / 1.2 / 2.4 / 4.8 / 9.6 / 19.2 / 28.8
Address		2 switches (address 00 - 127) or network programmable
Digital functions		read pressure, select units: Torr, mbar, Pa degas function, Pirani full scale adjust monitor gauge status detailed alarm and warning information
Analog functions		0 ... 10 V analog output pressure indication two setpoint relays A + B
Setpoint relays		2
Range	mbar	$1 \times 10^{-9}$ ... 100
Relay contact		n.o., potential free
Hysteresis	% of reading	10
Contact rating	V / A DC	60 / 0.5
Connector for RS485		D-sub, 9 pin, male
Connector for BPG (analog output, supply voltage, setpoints)		D-sub, 15 pin, male



# BPG400 (continued)

## Dimensions

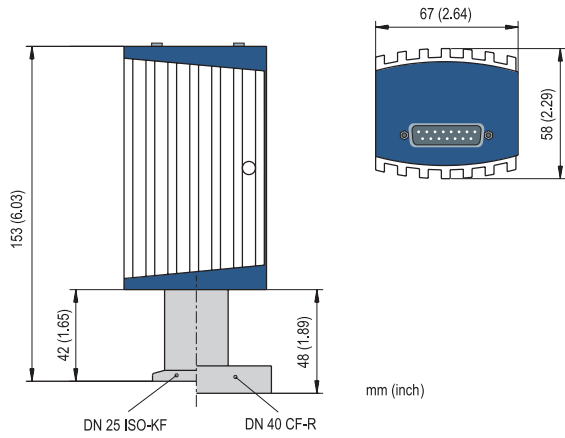

## Accessories

### Power supply 24 V DC / RS232C line

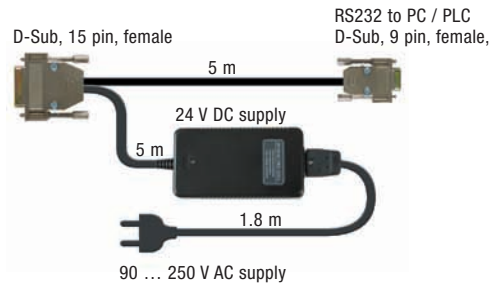

### Bakeout extension:

Allows measurement at flange temperatures up to 150°C.  
Fast and easy installation.



### Baffle:

Prevents contamination of the sensor.  
Easy installation into the vacuum connection - no tools required.



# Bayard-Alpert Pirani Gauge

## BPG402-S

The INFICON Bayard-Alpert Pirani Combination Gauge, BPG402-S, functions as two gauges in a single compact unit measuring from  $5 \times 10^{-10}$  mbar to atmosphere ( $3.8 \times 10^{-10}$  Torr to atmosphere). Combining technologies reduces the complexity of installation, setup, and integration. Choose the BPG402-S with dual yttrium oxide coated iridium filaments for affordable and repeatable process to base pressure measurements in one economical package. Sensing elements with on-board calibration data guarantees high reproducibility when exchanging sensors.



### Advantages

- Extremely wide measurement range from  $5 \times 10^{-10}$  mbar to atmosphere ( $3.8 \times 10^{-10}$  Torr to atmosphere)
- Excellent repeatability in the process pressure range from  $10^{-8}$  ...  $10^{-2}$  mbar of 5%
- Pirani interlock protects the filament from premature burnout
- Dual long-life yttrium oxide coated iridium filament
- Optional graphic display and Fieldbus interfaces available
- Automatic high vacuum Pirani adjustment reduces operator interventions
- Easy to exchange sensing element with on-board calibration data guarantees high reproducibility

### Applications

- Pressure measurement in semiconductor process and transfer chambers
- Industrial coating
- General vacuum measurement and control in the low to ultra high vacuum range

### Ordering Information

Type	BPG402-S	BPG402-S	BPG402-SL	BPG402-SP	BPG402-SD
	without display	with display	with long tube without display	with Profibus DP	with DeviceNet™
DN 25 ISO-KF	353-570	353-572	–	353-574	353-576
DN 40 CF-R	353-571	353-573	353-578	353-575	353-577
Replacement sensor 25 ISO-KF	354-494	354-494	–	354-494	354-494
Replacement sensor 40 CF-R	354-495	354-495	354-496	354-495	354-495

### Accessories

Power supply 24 V DC / RS232C line	353-511
Baffle	353-512

**BPG402-S** (continued)

**Specifications**

		<b>BPG402-S / -SL Standard</b>	<b>BPG402-S Display</b>
Measurement range	(air, O <sub>2</sub> , CO, N <sub>2</sub> )	mbar (Torr)	5 x 10 <sup>-10</sup> ... 1000 (3.8 x 10 <sup>-10</sup> ... 750)
Accuracy	10 <sup>-8</sup> ... 10 <sup>-2</sup> mbar	% of reading	±15
Repeatability	10 <sup>-8</sup> ... 10 <sup>-2</sup> mbar	% of reading	5
Degas <sup>1)</sup>	p < 7.2 x 10 <sup>-6</sup>	mbar	electron bombardment, max. 3 min
Pressure, max.		bar (absolute)	2
Temperature			
Operation (ambient)		°C	0 ... +50
Storage		°C	-20 ... +70
Bakeout at flange without electronics			
BPG402-S		°C	80
BPG402-SL		°C	150
Supply voltage		V / A DC	20 ... 28 / 0.8
Output signal analog		V	0 ... +10
Measurement range		V	0.774 ... 10
Voltage vs. pressure		V / Decade	0.75
Error signal		V	0.3 / 0.5
Load impedance, min.		kΩ	10
Set point relay			1
Range		mbar	1 x 10 <sup>-9</sup> ... 100
Relay contact			n.o., potential free
Hysteresis		% of reading	10
Contact rating		V / A DC	≤30 / ≤0.5
Digital functions			degas
Interface (digital) <sup>2)</sup>			RS232C
Emission control			automatic / manual via interface
Filament			dual Yt <sub>2</sub> O <sub>3</sub> coated Ir
Filament status			LED / digital output
Electrical connection			D-sub, 15 pin, male
Cable length, max. <sup>3)</sup>		m (ft)	100 (330)
Materials exposed to vacuum			Yt <sub>2</sub> O <sub>3</sub> , Ir, Pt, Mo, Cu, W, NiFe, NiCr, stainless steel, glass
Internal volume KF / CF		cm <sup>3</sup> (inch) <sup>3</sup>	24 (1.46) / 34 (2.1)
Weight KF / CF		g	285 / 550
Protection type			IP30

<sup>1)</sup> Reduced accuracy during degas

<sup>2)</sup> Simultaneous use of RS232C or VGC400 series controllers and Fieldbus is not allowed

<sup>3)</sup> For RS232C operation <30 m

**BPG402-S** (continued)

**Specifications**

		<b>BPG402-SP Profibus DP</b>
Baud rates	kBaud MBaud	9.6 / 19.2 / 93.75 / 187.5 / 500 1.5 / 12
Address		2 switches (address 00 - 127) or network programmable
Digital functions		read pressure, select units: Torr, mbar, Pa emission control, degas function monitor gauge status, filament status safe state allows definition of behavior in case of error detailed alarm and warning information
Analog functions		0 ... 10 V analog output pressure indication two setpoint relays A + B
Setpoint relays		2
Range	mbar	$1 \times 10^{-9}$ ... 100
Relay contact		n.o., potential free
Hysteresis	% of reading	10
Contact rating	V / A DC	$\leq 30$ / $\leq 0.5$
Connector for Profibus DP		D-sub, 9 pin, female
Connector for BPG (analog output, supply voltage, setpoints)		D-sub, 15 pin, male

**Specifications**

		<b>BPG402-SD DeviceNet™</b>
Protocol		DeviceNet, group 2 slave only
Data rate switch	kBaud	125, 250, 500 or network programmable
Cable length		
125 kbps	m (ft)	500 (1650)
250 kbps	m (ft)	250 (825)
500 kbps	m (ft)	100 (330)
MAC ID		2 switches (address 00 - 63) or network programmable
Digital functions		read pressure, select units: Torr, mbar, Pa emission control, degas function monitor gauge status, filament status safe state allows definition of behavior in case of error detailed alarm and warning information
Analog functions		0 ... 10 V analog output pressure indication two setpoint relays A + B
Specification		DeviceNet "Vacuum Gauge Device Profile"
Device type		"CG" for combination gauge
I / O slave messaging		polling only
Setpoint relays		2
Range	mbar	$1 \times 10^{-9}$ ... 100
Relay contact		n.o., potential free
Hysteresis	% of reading	10
Contact rating	V / A DC	$\leq 30$ / $\leq 0.5$
Supply voltage for DeviceNet	V / A DC	11 ... 25 / $< 0.2$
Supply voltage for gauge	V / A DC	20 ... 28 / 0.8
Connector for DeviceNet		microstyle, 5 pin
Connector for BPG (analog output, supply voltage, setpoints)		D-sub, 15 pin, male

# BPG402-S (continued)

## Dimensions

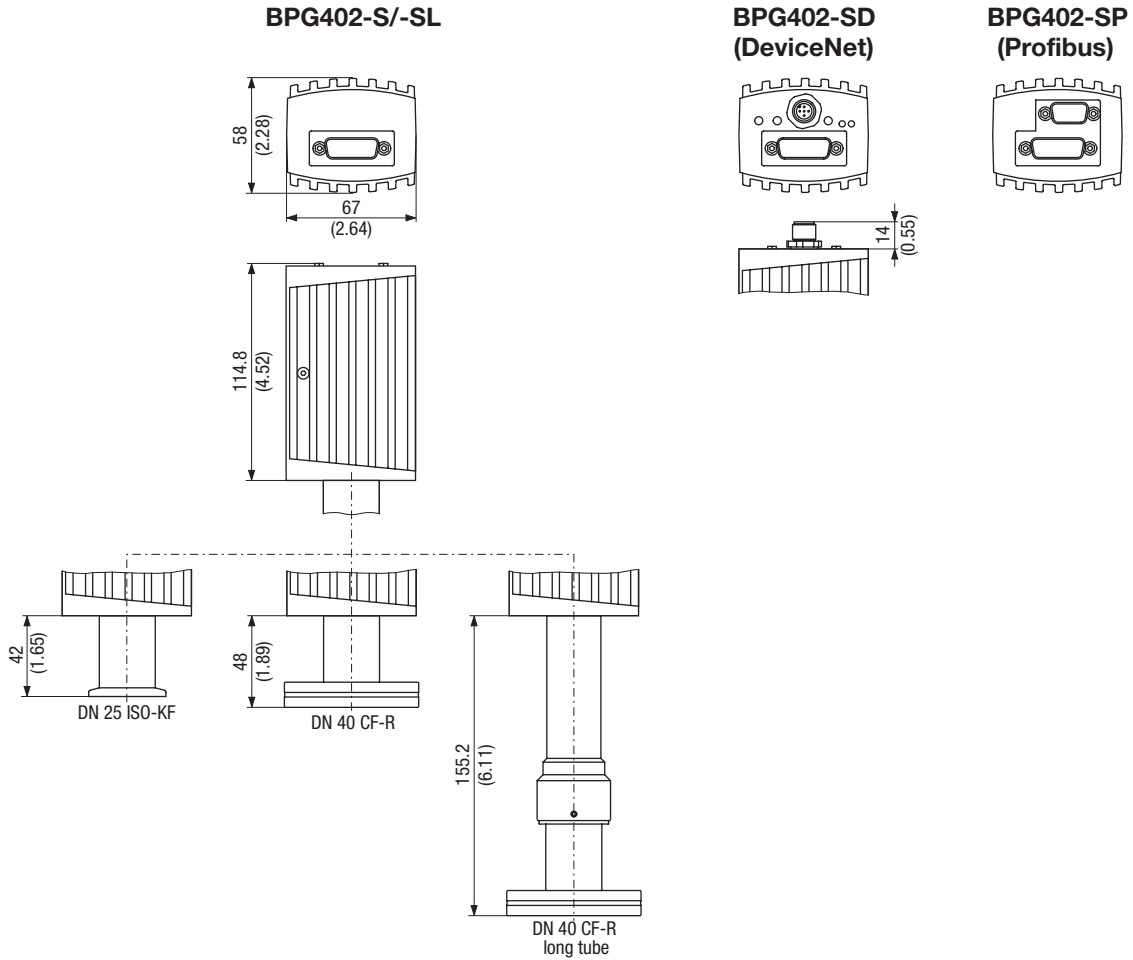

## Accessories

### Power supply 24 V DC / RS232C line

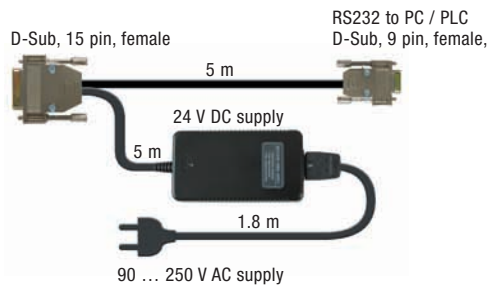

### Baffle:

Prevents contamination of the sensor.  
Easy installation into the vacuum connection - no tools required.

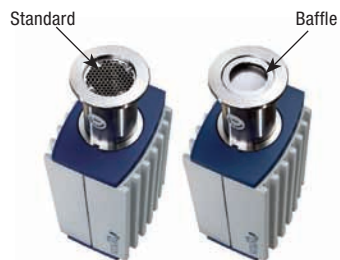

# High Pressure Hot Ionization Pirani Gauge

## HPG400

The INFICON High Pressure Hot Ionization Pirani Gauge, HPG400, combines High Pressure Hot Ionization and Pirani sensors in a single, compact, economical package to measure pressure from  $2 \times 10^{-6}$  mbar to atmosphere ( $1.5 \times 10^{-6}$  Torr to atmosphere). The HPG400 provides highly repeatable and reproducible pressure measurement for accurate sputter process pressure control.

### Advantages

- HPG400 saves cost and tool space and reduces the complexity of vacuum system installation and setup
- The high pressure hot ion gauge delivers accurate, reliable pressure measurements from  $1 \times 10^{-5}$  ... 1 mbar for improved process control
- User selectable hot ion emission activation between  $5 \times 10^{-2}$  and 1 mbar
- Pirani interlock protects the hot filament from premature burnout
- Optional graphic display and Fieldbus interfaces available
- Automatic high vacuum Pirani adjustment reduces operator interventions

### Applications

- Sputter applications in semiconductor manufacturing, electronics and media industry
- Industrial coating
- General vacuum measurement and control in the low to high vacuum range

### Ordering Information

Type	HPG400 without LCD display	HPG400 with LCD display	HPG400-SP with Profibus DP <sup>1)</sup>	HPG400-SD with DeviceNet <sup>1)</sup>
DN 25 ISO-KF	353-520	353-521	353-525	353-527
DN 40 CF-F	353-522	353-523	353-526	353-528
Replacement sensor 25 ISO-KF	354-487	354-487	354-487	354-487
Replacement sensor 40 CF-F	354-488	354-488	354-488	354-488

<sup>1)</sup> not available with LCD display

### Accessories

Power supply 24 V DC / RS232C line

353-511



**HPG400** (continued)

**Specifications**

		HPG400 Standard	HPG400 Display
Measurement range (air, N <sub>2</sub> )	mbar (Torr)	2 x 10 <sup>-6</sup> ... 1000	(1.5 x 10 <sup>-6</sup> ... 750)
Accuracy	10 <sup>-5</sup> ... 1 mbar	% of reading	±15 <sup>1)</sup>
Repeatability	10 <sup>-5</sup> ... 10 <sup>-1</sup> mbar	% of reading	2
	10 <sup>-1</sup> ... 100 mbar	% of reading	30
Hot ion emission on, selectable	mbar	1	
	mbar	5 x 10 <sup>-1</sup>	
	mbar	2 x 10 <sup>-1</sup>	
	mbar	1 x 10 <sup>-1</sup>	
	mbar	5 x 10 <sup>-2</sup>	
Pressure, max.	bar (absolute)	5	
Temperature			
Operation (ambient)	°C	0 ... +50	
Storage	°C	-20 ... +70	
Bakeout			
At flange	°C	80	
Electronics removed	°C	150	
Supply voltage	V / A DC	20 ... 28 / 0.8	
Output signal analog	V	0 ... +10.2	
Measurement range			
Hot cathode	V	1.5 ... 7.5	
Pirani	V	8.5 ... 9.75	
Voltage vs. pressure			
Hot cathode	V / Decade	1	
Pirani	V / Decade	0.25	
Error signal			
Hot cathode	V	0.3	
Pirani	V	0.5	
Load impedance, min.	kΩ	10	
Interface (digital) <sup>2)</sup>		RS232C	
Electrical connection		D-sub, 15 pin, male	
Cable length, max. <sup>3)</sup>	m (ft)	100 (330)	
Materials exposed to vacuum		Yt <sub>2</sub> O <sub>3</sub> , Ir, Pt, Mo, Cu, W, NiFe, NiCr, stainless steel, glass	
Internal volume KF / CF	cm <sup>3</sup> (inch) <sup>3</sup>	20 (1.2) / 30 (1.8)	
Weight KF / CF	g	430 / 695	
Protection type		IP30	

<sup>1)</sup> Accuracy from 10<sup>-5</sup> mbar to the selected hot ion emission on value

<sup>2)</sup> Simultaneous use of RS232C or VGC400 series controllers and Fieldbus is not allowed

<sup>3)</sup> For RS232C operation <30 m

## HPG400 (continued)

### Specifications

			<b>HPG400-SD DeviceNet™</b>
Protocol			DeviceNet, group 2 slave only
Data rate switch	kBaud		125, 250, 500 or network programmable
Cable length			
125 kbps	m (ft)		500 (1650)
250 kbps	m (ft)		250 (825)
500 kbps	m (ft)		100 (330)
MAC ID			2 switches (address 00 - 63) or network programmable
Network size			up to 64 nodes per segment
Digital functions			read pressure, select units: Torr, mbar, Pa Pirani full scale adjust monitor gauge status safe state allows definition of behavior in case of error detailed alarm and warning information
Analog functions			0 ... 10 V analog output pressure indication two setpoint relays A + B
Visual communication indicators			LED network status (green / red) LED module status (green / red)
Specification			DeviceNet "Vacuum Gauge Device Profile"
Device type			"CG" for combination gauge
I / O slave messaging			polling only
Setpoint relays			2
Range	mbar		$2 \times 10^{-6}$ ... 100
Relay contact			n.o., potential free
Hysteresis	% of reading		10
Contact rating	V DC / A		60 / 0.5
Supply voltage for DeviceNet	V DC / A		11 ... 25 / 0.5
Supply voltage for gauge	V DC		20 ... 28
Connector for DeviceNet			microstyle, 5 pin
Connector for HPG (analog output, supply voltage, setpoints)			D-sub, 15 pin, male

### Specifications

			<b>HPG400-SP Profibus DP</b>
Baud rates	kBaud MBaud		9.6 / 19.2 / 93.75 / 187.5 / 500 1.5 / 12
Address			2 switches (address 00 - 127) or network programmable
Digital functions			read pressure, select units: Torr, mbar, Pa Pirani full scale adjust monitor gauge status safe state allows definition of behavior in case of error detailed alarm and warning information
Analog functions			0 ... 10 V analog output pressure indication two setpoint relays A + B
Setpoint relays			2
Range	mbar		$1 \times 10^{-6}$ ... 100
Relay contact			n.o., potential free
Hysteresis	% of reading		10
Contact rating	V DC / A		60 / 0.5
Connector for Profibus DP			D-sub, 9 pin, female
Connector for HPG (analog output, supply voltage, setpoints)			D-sub, 15 pin, male



## HPG400 (continued)

### Dimensions

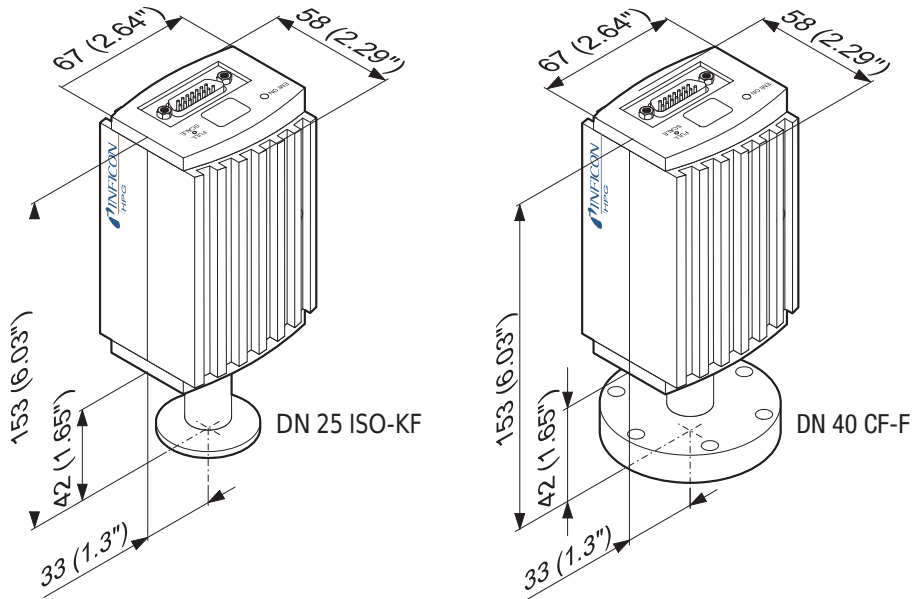

### Accessories

#### Power supply 24 V DC / RS232C line

HPG400  
D-Sub, 15 pin, female

RS232 to PC / PLC  
D-Sub, 9 pin, female

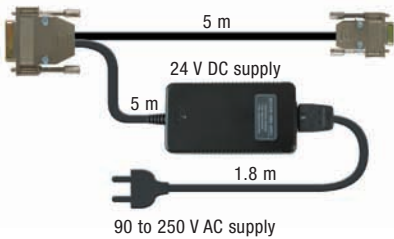

# Bayard-Alpert Pirani Capacitance Diaphragm Gauge

## TripleGauge® BCG450

The INFICON Bayard-Alpert Pirani Capacitance Diaphragm Gauge, BCG450, combines the advantages of three different technologies in a single, compact, economical package to measure process and base pressure from  $5 \times 10^{-10}$  to 1500 mbar ( $3.75 \times 10^{-10}$  to 1125 Torr). The BCG450 is designed to take the place of three sensors (hot ion, convection enhanced Pirani and vacuum switch), thus reducing cost and valuable tool space.

### Advantages

- BCG450 saves cost and tool space and reduces the complexity of vacuum measurement installation and setup
- Gas-type-independent pressure measurement above 10 Torr provides more reliable loadlock control for any gas-mixture
- Pirani interlock protects the hot filament from premature burnout
- Automatic high vacuum and atmospheric Pirani adjustment reduces operator interventions
- Differential pressure measurement at atmosphere eliminates uncertainty related to atmospheric pressure changes
- Easy-to-exchange sensing element with on-board calibration data guarantees reproducibility
- Optional graphic display and Fieldbus interfaces available

### Applications

- Pressure measurement in semiconductor process, transfer and loadlock chambers
- Industrial coating
- General vacuum measurement and control on systems in the low to ultra-high vacuum range



2004 Award Winner



TripleGauge  
Bayard-Alpert  
Pirani Capacitance  
Diaphragm Gauge

### Ordering Information

Type	BCG450 without LCD display	BCG450 with LCD display	BCG450-SP with Profibus DP <sup>2)</sup>	BCG450-SD with DeviceNet <sup>2)</sup>	BCG450-SR with RS485 <sup>1)2)</sup>
DN 25 ISO-KF	353-550	353-552	353-554	353-557	353-559
DN 40 CF-R	353-551	353-553	353-556	353-558	353-560
Replacement sensor 25 ISO-KF	354-492	354-492	354-492	354-492	354-492
Replacement sensor 40 CF-R	354-493	354-493	354-493	354-493	354-493

<sup>1)</sup> available on request

<sup>2)</sup> not available with LCD display

### Accessories

Power supply 24V DC / RS 232 C line	353-511
Baffle	353-512
Centering ring with baffle	211-113

## TripleGauge® BCG450 (continued)

### Specifications

		BCG450 Standard	BCG450 Display
Measurement range	mbar (Torr)	5 x 10 <sup>-10</sup> to 1500 (3.75 x 10 <sup>-10</sup> to 1125)	
Accuracy	10 <sup>-8</sup> to 10 <sup>-2</sup> mbar	% of reading ±15	
	10 <sup>-2</sup> to 50 mbar	% of reading ±15	
	50 to 950 mbar	% of reading ±5	
	950 to 1050 mbar	% of reading ±2.5	
Repeatability	10 <sup>-8</sup> ... 10 <sup>-2</sup> mbar	% of reading 5	
Hot ion emission on	mbar	2 x 10 <sup>-2</sup> (high)	
(selectable high / low, via RS232 / Fieldbus)	mbar	8 x 10 <sup>-3</sup> (low)	
Degas <sup>1)</sup> p < 7.2 x 10 <sup>-6</sup>	mbar	Electron bombardment, max. 3 min	
Pressure, max.	bar (absolute)	5	
Temperature			
Operation (ambient)	°C	0 to +50	
Storage	°C	-20 to +70	
Bakeout			
At flange	°C	80	
Electronics removed	°C	150	
Supply	V / A DC	20 to 28 / 0.8	
Output signal analog			
Measurement range	V	0 to 10.3	
Relation voltage / pressure	V / Decade	0.774 to 10.3	
Error signal	V	0.3 / 0.5	
Minimum load	kΩ	10	
Interface (digital) <sup>2)</sup>		RS232C	
Connector		D-sub, 15 pin, male	
Cable length, max. <sup>3)</sup>	m (ft)	100 (330)	
Materials exposed to vacuum		Yt <sub>2</sub> O <sub>3</sub> , Ir, Mo, Cu, W, NiFe, NiCr, Al <sub>2</sub> O <sub>3</sub> , SnAg, stainless steel, glass	
Internal volume KF / CF	cm <sup>3</sup> (inch) <sup>3</sup>	24 (1.46) / 34 (2.1)	
Weight KF / CF	g	285 / 550	
Protection type		IP30	

<sup>1)</sup> Reduced accuracy during degas

<sup>2)</sup> Simultaneous use of RS232C or VGC400 series controllers and Fieldbus is not allowed

<sup>3)</sup> For RS232C operation <30m

## TripleGauge® BCG450 (continued)

## Specifications

		BCG450-SD DeviceNet™
Protocol		DeviceNet, group 2 slave only
Data rate switch	kBaud	125, 250, 500 or network programmable
Cable length		
125 kbps	m (ft)	500 (1650)
250 kbps	m (ft)	250 (825)
500 kbps	m (ft)	100 (330)
MAC ID		2 switches (address 00 - 63) or network programmable
Network size		Up to 64 nodes per segment
Digital functions		Read pressure, select units: Torr, mbar, Pa Degas function Monitor gauge status Safe state allows definition of behavior in case of error Detailed alarm and warning information
Analog functions		0 to 10 V analog output pressure indication Two setpoint relays A + B
Visual communication indicators		LED network status (green / red) LED module status (green / red)
Specification		DeviceNet "Vacuum Gauge Device Profile"
Device type		"CG" for combination gauge
I / O peer to peer messaging		polling only
Configuration consistency value		no
Faulted node recovery		no
Baud rates	kBaud	125 / 250 / 500
Master / Scanner		no
I / O slave messaging		polling only
Setpoint relays		2
Range	mbar	$1 \times 10^{-9}$ to 1400
Relay contact		n.o., potential free
Hysteresis	% of reading	10
Contact rating	V / A DC	60 / 0.5
Connector		D-sub, 15 pin, male
Supply for DeviceNet	V / A DC	11 to 25 / 0.5
Supply for gauge	V DC	20 to 28
Connector for DeviceNet		Microstyle, 5 pin
Connector for BCG (analog output, supply voltage, setpoints)		D-sub, 15 pin, male

## TripleGauge® BCG450 (continued)

### Specifications

<b>BCG450-SP Profibus DP</b>		
Baud rates	kBaud MBaud	9.6 / 19.2 / 93.75 / 187.5 / 500 1.5 / 12
Address		2 switches (address 00 - 127) or network programmable
Digital functions		Read pressure, select units: Torr, mbar, Pa Degas function Monitor gauge status Safe state allows definition of behavior in case of error Detailed alarm and warning information
Analog functions		0 to 10 V analog output pressure indication Two setpoint relays A + B
Setpoint relays		2
Range	mbar	$1 \times 10^{-9}$ to 1400
Relay contact		n.o., potential free
Hysteresis	% of reading	10
Contact rating	V / A DC	60 / 0.5
Connector		
for Profibus DP		D-sub, 9 pin, female
for BCG (analog output, supply voltage, setpoints)		D-sub, 15 pin, male

### Specifications

<b>BCG450-SR RS485</b>		
Baud rates	kBaud	0.3 / 1.2 / 2.4 / 4.8 / 9.6 / 19.2 / 28.8
Address		2 switches (address 00 - 127) or network programmable
Digital functions		Read pressure, select units: Torr, mbar, Pa Degas function, Pirani full scale adjust Monitor gauge status Detailed alarm and warning information
Analog functions		0 to 10 V analog output pressure indication Two adjustable setpoint relays A + B
Setpoint relays		2
Range	mbar	$1 \times 10^{-9}$ to 100
Relay contact		n.o., potential free
Hysteresis	% of reading	10
Contact rating	V / A DC	60 / 0.5
Connector		
for RS485		D-sub, 9 pin, male
for gauge (analog output, supply voltage, setpoints)		D-sub, 15 pin, male

# TripleGauge® BCG450 (continued)

## Dimensions

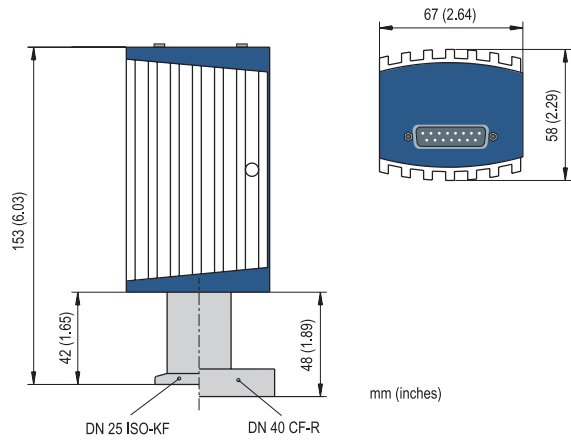

## Accessories

### Power supply 24 V DC / RS 232 C line

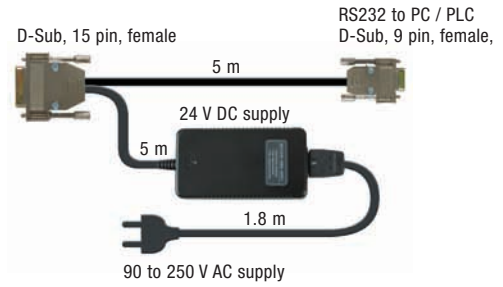

### Baffle

Prevents contamination of the sensor.  
Easy installation into the vacuum connection - no tools required.



# Pirani Standard Gauge

## PSG050 / PSG051

The INFICON Pirani Standard Gauges PSG050 & PSG051 use the vacuum gauge controller VGC012 or VGC023 as operating units.

### Advantages

- Measurement range  $5 \times 10^{-4}$  to 1000 mbar ( $3.75 \times 10^{-4}$  to 750 Torr)
- Tungsten or platinum filament
- Temperature compensated 0 °C to 40 °C
- Constant filament temperature

#### PSG050:

- Aluminum sensing cell with tungsten filament
- Excellent temperature compensation

#### PSG050 1/8" NPT:

- Stainless steel sensing cell with tungsten filament

#### PSG051:

- Stainless steel sensor with platinum filament and ceramics feedthrough
- Well suited for corrosive processes and high levels of water vapour



### Operating Units

- Vacuum Gauge Controller VGC012 / VGC023

### Ordering Information

Type	PSG050	PSG050 1/8" NPT	PSG051
DN 16 ISO-KF	<b>399-500</b>	–	<b>399-502</b>
1/8" NPT	–	<b>399-501</b>	–
Replacement sensor DN 16 ISO-KF	<b>350-980</b>	–	<b>350-981</b>

Ordering information for cables - see Data Sheets of VGC012 / VGC023

## Specifications

		PSG050	PSG050 1/8" NPT	PSG051
Measurement range	mbar (Torr)		5 x 10 <sup>-4</sup> ... 1000 (3.75 x 10 <sup>-4</sup> ... 750)	
Temperature				
Operation (ambient)	°C	0 ... +40	0 ... +40	0 ... +40
Storage	°C	80	80	80
Filament		tungsten	tungsten	platinum
Filament temperature	°C	110	110	110
Pressure, max. absolute	bar	3	3	10
Internal volume	cm <sup>3</sup>	11	11	10
Vacuum connection		DN 16 ISO-KF	1/8" NPT	DN 16 ISO-KF
Materials exposed to vacuum		tungsten, aluminum, nickel-plated steel, stainless steel, NiFe, glass, CrNi, epoxy cement	tungsten, stainless steel, NiFe, glass, CrNi, epoxy cement	platinum, stainless steel, CrNi, AL <sub>2</sub> O <sub>3</sub> , NiFe
Additional specifications - see Data Sheets and Operating Manuals VGC012 / VGC023				

## Dimensions

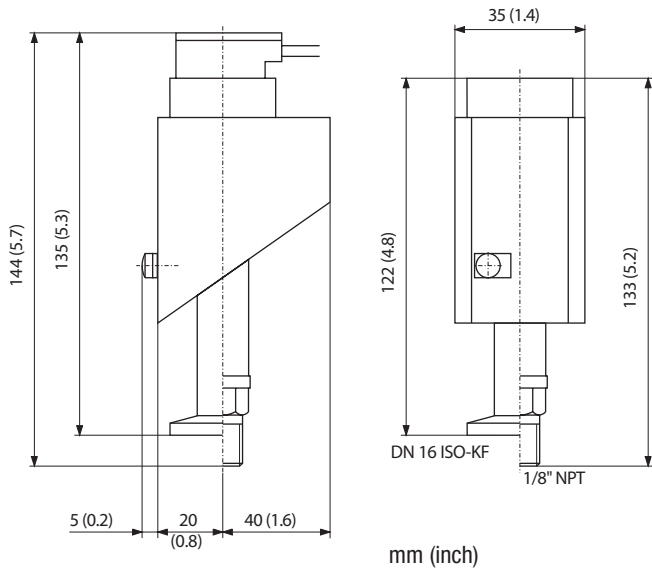



# Pirani Standard Gauge

## PSG100-S, PSG101-S

The INFICON Pirani Standard Gauges PSG100-S and PSG101-S are especially designed for easy integration into vacuum systems using Profibus DP or DeviceNet™ fieldbus protocols. The gauges are equipped with a setpoint and for corrosive applications, a platinum filament version is available.



### Advantages

- Fieldbus interface (Profibus DB, DeviceNet™) for easy integration into vacuum systems using network communications
- For corrosive applications or high levels of water vapors the PSG101-S uses a platinum filament and a Al<sub>2</sub>O<sub>3</sub> ceramic feedthrough
- Setpoint with adjustable threshold over a wide range
- Mounts in any orientation
- Logarithmic analog output signal
- Sensor cell is easily replaced

### Applications

- Processes with corrosive gases (PSG101-S)
- Fore vacuum pressure monitoring
- Control of high vacuum ionization gauges
- Safety circuits in vacuum systems
- General vacuum measurement and control in the fine and rough vacuum range

### Ordering Information

Type	PSG100-S DN 16 ISO-KF, Tungsten	PSG101-S DN 16 ISO-KF, Platinum
With setpoint	350-020	350-030
With DeviceNet™ (PSG100-SD, PSG101-SD)	350-021	350-031
With Profibus DP (PSG100-SP, PSG101-SP)	350-022	350-032
Replacement sensor (DN16 ISO KF)	350-980	350-981

## PSG100-S, PSG101-S (continued)

**Specifications**

		PSG100-S Tungsten	PSG101-S Platinum
Measurement range (air, O <sub>2</sub> , CO, N <sub>2</sub> )	mbar Torr	5 x 10 <sup>-4</sup> ... 1000 3.8 x 10 <sup>-4</sup> ... 750	
Filament material		tungsten	platinum
Mounting orientation		any	
Feldbus protocol		DeviceNet™ or Profibus DP	
Setpoint		1	
Range	mbar	1 x 10 <sup>-3</sup> ... 500	
Relay contact		n.o. / potential free	
Hysteresis		≈30% of adjusted pressure	
Contact rating	VDC / A	60 / 0.5	
Relay status		LED, green	
Pressure, max. (absolute)	bar	3	10 <sup>1)</sup>
Temperature			
Operation (ambient)	°C	+10 ... +50	
Storage	°C	-20 ... +70	
Bakeout at flange	°C	80	
Power supply			
Voltage	V DC	14.5 ... 36	
Consumption, max.	W	<2	
Output signal analog	V	0 ... 10.6	
Measurement range	V	0.66 ... 10	
Relation voltage / pressure	V / Decade	1.333	
Connector		FCC 68, female, 8 pin (shielded)	
Cable length, max. (analog)	m (ft)	100 (330)	
Materials exposed to vacuum		tungsten, Al, nickel-plated steel, stainless steel, NiFe, glass, CrNi8020, epoxy cement	platinum, stainless steel, CrNi, Al <sub>2</sub> O <sub>3</sub> ceramics, NiFe, Mo, Ni
Flange		DN 16 ISO-KF	
Internal volume	DN 16 ISO-KF cm <sup>3</sup> (inch) <sup>3</sup>	11 (0.67)	
Weight, approx.	DN 16 ISO-KF g	290	
Protection type		IP40	

1) Threaded connections only

**Specifications**

		PSG100-SP Profibus DP, PSG101-SP Profibus DP
Supported baud rates (for auto detection)	kBaud	9.6 / 19.2 / 93.75 / 187.5 / 500 / 1500
Expanded user parameter data	Bytes	5
Configuring		
Number of input and output data		2
Sync-Mode and Freeze-Mode		Yes
Connector		D sub, 9 pin

## Specifications

		PSG100-SD DeviceNet™, PSG101-SD DeviceNet
Device type		generic
Explicit peer to peer messaging		no
I / O peer to peer messaging		no
Configuration consistency value		no
Faulted node recovery		no
Baud rates	kBaud	125 / 250 / 500
Master / Scanner		no
I / O slave messaging		
Bit Strobe		yes
Polling		yes
Cyclic		yes
Change of State (COS)		yes
Supply for DeviceNet	V DC	11 to 25
Connector for DeviceNet		Phoenix Combicon, 5 pin

## Dimensions

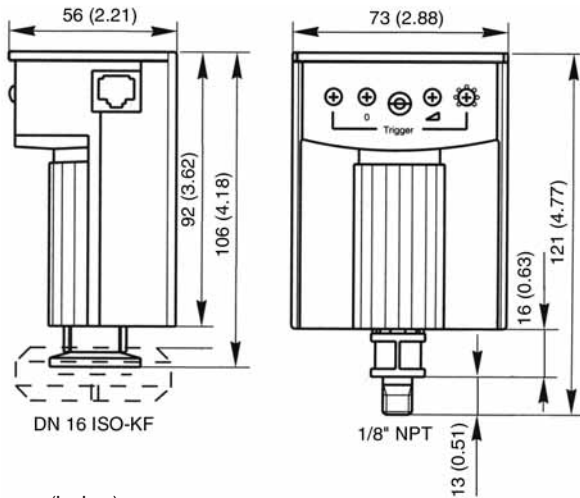

mm (inches)

# Pirani Standard Gauge

## PSG500/-S, PSG502-S, PSG510-S, PSG512-S

The INFICON Pirani Standard Gauges, PSG500, PSG502-S, PSG510-S and PSG512-S, employ the most advanced digital Pirani technology available in the marketplace. The rugged stainless steel sensor cell and compact design qualify them for use on semiconductor systems and for standard applications, such as fore vacuum lines.

### Advantages

- Easy push button ATM and HV adjustment
- Space saving rugged design
- Aluminum housing
- Mounts in any orientation
- Stainless steel measuring cell with metal-sealed feedthrough
- Logarithmic signal output for easy integration
- 10 bar absolute overpressure with threaded connections
- 250°C bakeable version
- Nickel filament option for corrosive applications
- Ceramic feedthrough for extremely corrosive applications (PSG510 & PSG512)
- Optional setpoints
- RoHS compliance

### Applications

- Controlling high vacuum ionization gauges
- Fore vacuum pressure monitoring
- Safety circuits in vacuum systems
- General vacuum measurement and control in the fine and rough vacuum range



## PSG500/-S, PSG502-S, PSG510-S, PSG512-S (continued)

## Ordering Information

Type Setpoints Filament	PSG500 none tungsten	PSG500-S two setpoints tungsten	PSG502-S two setpoints nickel	PSG510-S two setpoints tungsten	PSG512-S two setpoints nickel
DN 16 ISO-KF	350-060	350-080	350-140	350-200	350-300
DN 16 CF-R	350-062	350-082	350-142		
1/8" NPT	350-061	350-081	350-141		
8 VCR®	350-064	350-084	350-144		
4 VCR®	350-065	350-085	350-145		
1/2" tube	350-063	350-083	350-143		
7/16-20 UNF	350-066	350-086	350-146		
DN 16 ISO-KF long tube	350-067	350-087	350-147		
DN 16 CF-R long tube	350-068	350-088	350-148		
<b>Replacement sensor</b> Filament		tungsten	nickel	tungsten	nickel
DN 16 ISO-KF		350-920	350-900	350-930	350-940
DN 16 CF-R		350-922	350-902		
1/8" NPT		350-921	350-901		
8 VCR®		350-924	350-904		
4 VCR®		350-926	350-906		
1/2" tube		350-923	350-903		
7/16-20 UNF		350-925	350-905		
DN 16 ISO-KF long tube		350-927	350-907		
DN 16 CF-R long tube		350-928	350-908		

**PSG500/-S, PSG502-S, PSG510-S, PSG512-S** (continued)

**Specifications**

Type Filament		PSG500 tungsten	PSG500-S tungsten	PSG502-S nickel	PSG510-S tungsten	PSG512-S nickel
Measuring principle		thermal conductance according to Pirani				
Measurement range (air, O <sub>2</sub> , CO, N <sub>2</sub> )	mbar	5 x 10 <sup>-4</sup> to 1000				
Accuracy (N <sub>2</sub> )	1 x 10 <sup>-3</sup> ... 100 mbar	% of reading				
	5 x 10 <sup>-4</sup> ... 1 x 10 <sup>-3</sup> mbar	% of reading				
	100 ... 1000 mbar	% of reading				
Resolution		% of reading				
Repeatability (air)	1 x 10 <sup>-3</sup> ... 100 mbar	% of reading				
Output signal (measurement signal)						
Voltage range	V	0 ... +10.3				
Measurement range	V	+1.9 ... +10.0				
Voltage vs. pressure		logarithmic 1.286 V/decade				
Error signal	V	0 ... +0.5 (filament rupture)				
Output impedance	Ω	2 x 4.7				
Minimum loaded impedance	kΩ	10, short-circuit proof				
Response time	ms	80				
Gauge identification	kΩ	27.0, referenced to supply common				
Adjustment		one tactile switch for ATM and HV adjustment				
Setpoint		none		2		
Setting range	mbar	2 x 10 <sup>-3</sup> ... 500				
Hysteresis	% of reading	10% above lower threshold				
Relay contact	V DC / A DC	30 / 0.5 floating				
Switching time	ms	<20				
Supply voltage						
At gauge	V DC	+14 ... +30				
Ripple	V <sub>pp</sub>	≤1				
Current consumption	mA	<500 (max. starting current)				
Power consumption	W	≤1				
Electrical connection		FCC 68 / RJ45 appliance connector, 8 poles, male				
Sensor cable		8 poles plus shielding				
Cable length	m	≤100 (8 x 0.14 mm <sup>2</sup> )				
Materials exposed to vacuum		glass, Ni, NiFe			Al <sub>2</sub> O <sub>3</sub> , Ni,	
Filament		DIN 1.4301/1.4305/1.4435			DIN 1.3981/1.4305/1.4435	
		W	W	Ni	W	Ni
Internal volume						
DN 16 ISO-KF, DN 16 CF-R, 7/16-20 UNF	cm <sup>3</sup>	1.5				
DN 16 ISO-KF & DN 16 CF-R long tube	cm <sup>3</sup>	10				
1/8" NPT, 4 VCR, 8 VCR, 1/2" tube	cm <sup>3</sup>	2				
Admissible pressure	bar (absolute)	10, limited to inert gases				
Admissible temperature						
Operation	°C	+5 ... +60				
Vacuum connection <sup>1)</sup>	°C	80 / 250 <sup>2)</sup>				
Storage	°C	-20 ... +65				
Mounting orientation		any				
Degree of protection		IP40				
Weight						
DN 16 ISO-KF, 7/16-20 UNF	g	80				
DN 16 CF-R, 4 VCR	g	100				
1/8" NPT, 1/2" tube	g	70				
8 VCR, DN 16 ISO-KF long tube	g	130				
DN 16 CF-R long tube	g	140				

<sup>1)</sup> In horizontal mounting orientation

<sup>2)</sup> Long tube

# PSG500/-S, PSG502-S, PSG510-S, PSG512-S (continued)

## Dimensions

mm (inch)

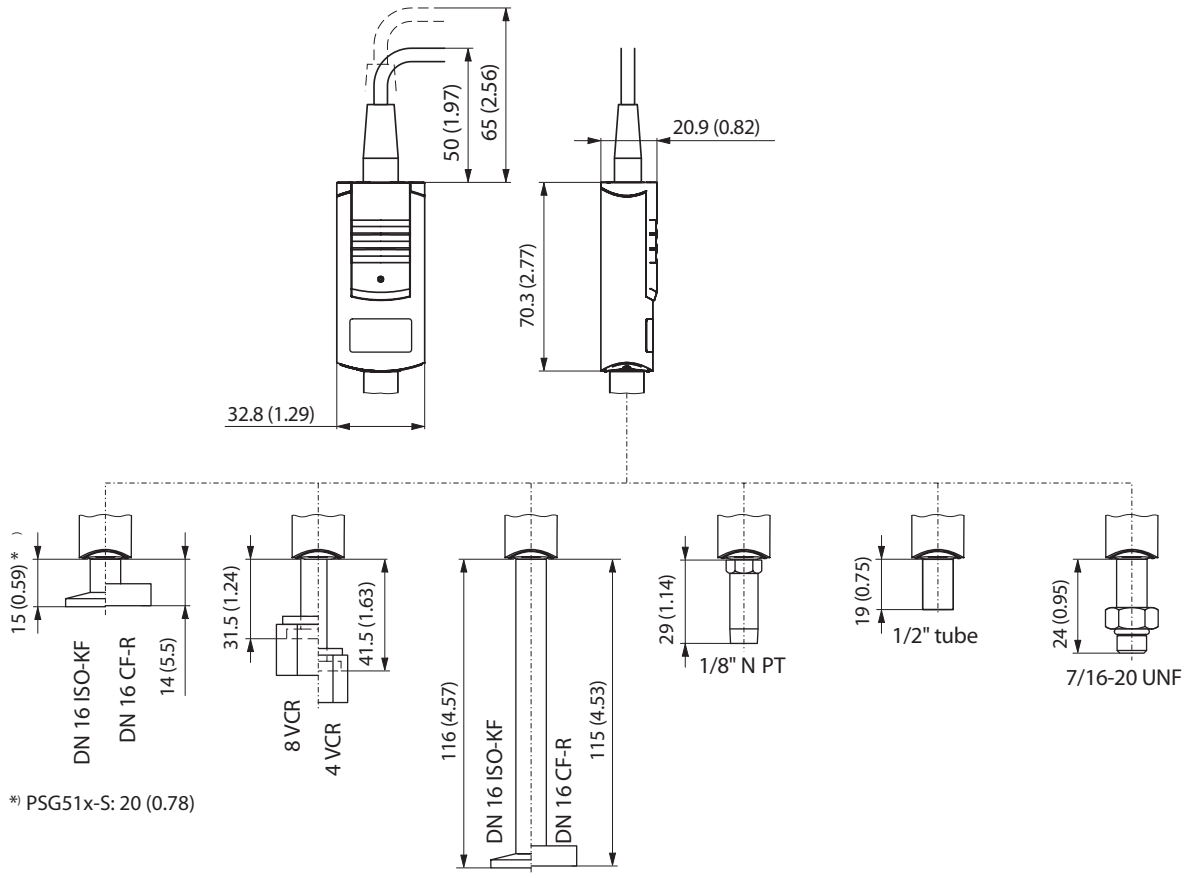

# Pirani Capacitance Diaphragm Gauge

## PCG400, PCG410

The INFICON PCG Pirani Capacitance Diaphragm Gauge is the first vacuum gauge to combine the advantages of a ceramic capacitance diaphragm gauge and the cost effectiveness of a Pirani in one compact package. In the measurement range between 100 mbar (75 Torr) and atmosphere, where Pirani sensors lose sensitivity, the capacitance diaphragm technology supplies accurate, gas-type and flow independent measurement values up to 1500 mbar (1125 Torr). Available with up to two integrated relays, the PCG can eliminate the need for 1/2 atm or other expensive switches. To simplify tool integration, the Pirani and CDG signals are combined into a single log/linear analog output spanning the full range of the gauge.



### Advantages

- Gas-type-independent above 100 mbar (75 Torr) - enables safe venting with any gas mixture
- Higher accuracy and reproducibility at atmosphere - for reliable detection of atmospheric pressure, no frequent readjustment at atmospheric pressure anymore
- Independence of mounting position - provides engineering freedom in tool design
- Faster atmosphere detection - eliminates waiting time and thus shortens process cycle time
- Compact design - saves valuable space on the tool
- One log/linear output signal over the entire range - for easy tool integration

### Applications

- Loadlock control
- Forevacuum pressure monitoring
- Safety circuits in vacuum systems
- General measurement and control in the medium and rough vacuum range
- Control of high vacuum ionization gauges



### Ordering Information

Type Setpoint Connector	PCG400 none FCC 68	PCG400-S with 2 setpoints FCC 68	PCG410 none 9 D-Sub	PCG410-S with 1 setpoint 9 D-Sub
DN 16 ISO-KF	355-000	355-010	355-020	355-030
1/8" NPT	355-001	355-011	355-021	355-031
DN 16 CF-F	355-002	355-012	355-022	355-032
8 VCR®, female	355-004	355-014	355-024	355-034
4 VCR®, female	355-005	355-015	355-025	355-035
4 VCR® 90°, female			355-026	

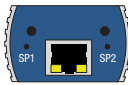

# PCG400, PCG410 (continued)

## Specifications

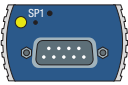
	<b>PCG400</b> <b>FCC 68</b> 		<b>PCG400-S</b> <b>FCC 68</b> 		<b>PCG410</b> <b>9 D-Sub</b> 		<b>PCG410-S</b> <b>9 D-Sub</b> 	
	for INFICON VGC40x vacuum gauge controllers				for direct connection to PC / PLC			
Electrical connection	FCC 68, 8 pin				D-Sup, 9 pin, male			
Measurement range	mbar				5 x 10 <sup>-4</sup> to 1500			
	Torr				3.8 x 10 <sup>-4</sup> to 1125			
Accuracy (N <sub>2</sub> )								
1 x 10 <sup>-3</sup> ... 50 mbar	% of reading				±15%			
50 ... 950 mbar	% of reading				±5%			
ATM (950 ... 1050 mbar)	% of reading				±2.5%			
Repeatability (N <sub>2</sub> )								
1 x 10 <sup>-3</sup> to 1100 mbar	% of reading				±2%			
Mounting orientation					any			
Setpoint	none		2		none		1	
Range (N <sub>2</sub> )	mbar		1.5 x 10 <sup>-3</sup> ... 1400				1.5 x 10 <sup>-3</sup> ... 1400	
Relay contact			n.o. / potential free				n.o. / potential free	
Hysteresis			10% of threshold				10% of threshold	
Contact rating	V DC / A		30 / 1				30 / 1	
Relay status			LED, green				LED, green	
Pressure, max. (absolute)	bar				5			
Temperature								
Operation (ambient)	°C				+10 ... +50			
Storage	°C				-20 ... +65			
Bakeout at flange	°C				+80			
Filament	°C				<160			
Power supply								
Voltage	V DC				15 ... 30 (Ripple ≤ 1 V <sub>pp</sub> )			
Consumption, max.	W				2.5			
Output signal analog	V		0 ... +10.3				0 ... +9.0	
Measurement range, logarithmic	V		+1.9 ... +10.23				+2.2 ... +8.68	
Relation voltage / pressure	V / Decade		1.286				1	
Response time	ms		10				10	
Connector	FCC 68, female, 8 pin (shielded)							
Cable length, max.	m (ft)				100 (330)			
Materials exposed to vacuum	Al <sub>2</sub> O <sub>3</sub> (>99.5%), tungsten, stainless steel, Cu, glass, NiFe, Ni SnAg, AgPd							
Internal volume KF / CF	cm <sup>3</sup>				6 / 8			
Weight KF / CF	g				90 / 120			
Protection type					IP 40			

# PCG400, PCG410 (continued)

## Dimensions

mm (inch)

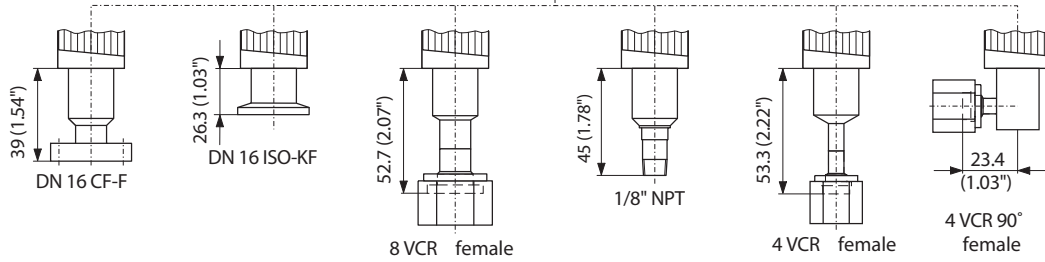
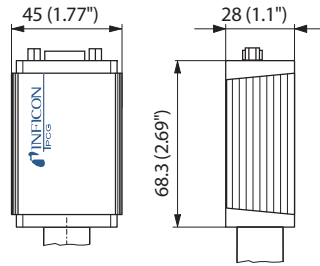

# Pirani Capacitance Diaphragm Gauge

## PCG550, PCG552, PCG554

The INFICON Pirani Capacitance Diaphragm Gauge (PCG55x) combines the INFICON ceramic capacitance diaphragm sensor technology with the advantages of a Pirani unit in a single product.

In the measurement range between 10 mbar and atmosphere the capacitance diaphragm technology provides gas-type independent, highly accurate values for reliable pressure measurement. The PCG55x offers also a variety of features which allows the right product configuration for the demanded application..



### Advantages

- Gas-type independent above 10 mbar – allows safe venting with any gas mixture
- High accuracy and reproducibility at atmosphere – for reliable atmospheric pressure detection
- Fast atmospheric detection – eliminates waiting time and shortens process cycle
- Versatile of mounting orientation – provides engineering freedom in tool design
- Available with Tungsten (PCG550) or Nickel (PCG552) filament or with a fully ceramic coated (PCG554) sensor unit for highly corrosive applications
- Easy to exchange plug & play sensor element with on-board calibration data – guarantees high reproducibility and low cost of ownership
- Eligible output signal for easy integration
- Optional atmospheric switch, display and digital interfaces
- Diagnostic port on all versions

### Applications

- Load Lock control
- Fore vacuum pressure measurement
- Safety circuits in vacuum systems
- General vacuum measurement and control in the medium and rough vacuum range

# PCG550, PCG552, PCG554 (continued)

## Ordering Information

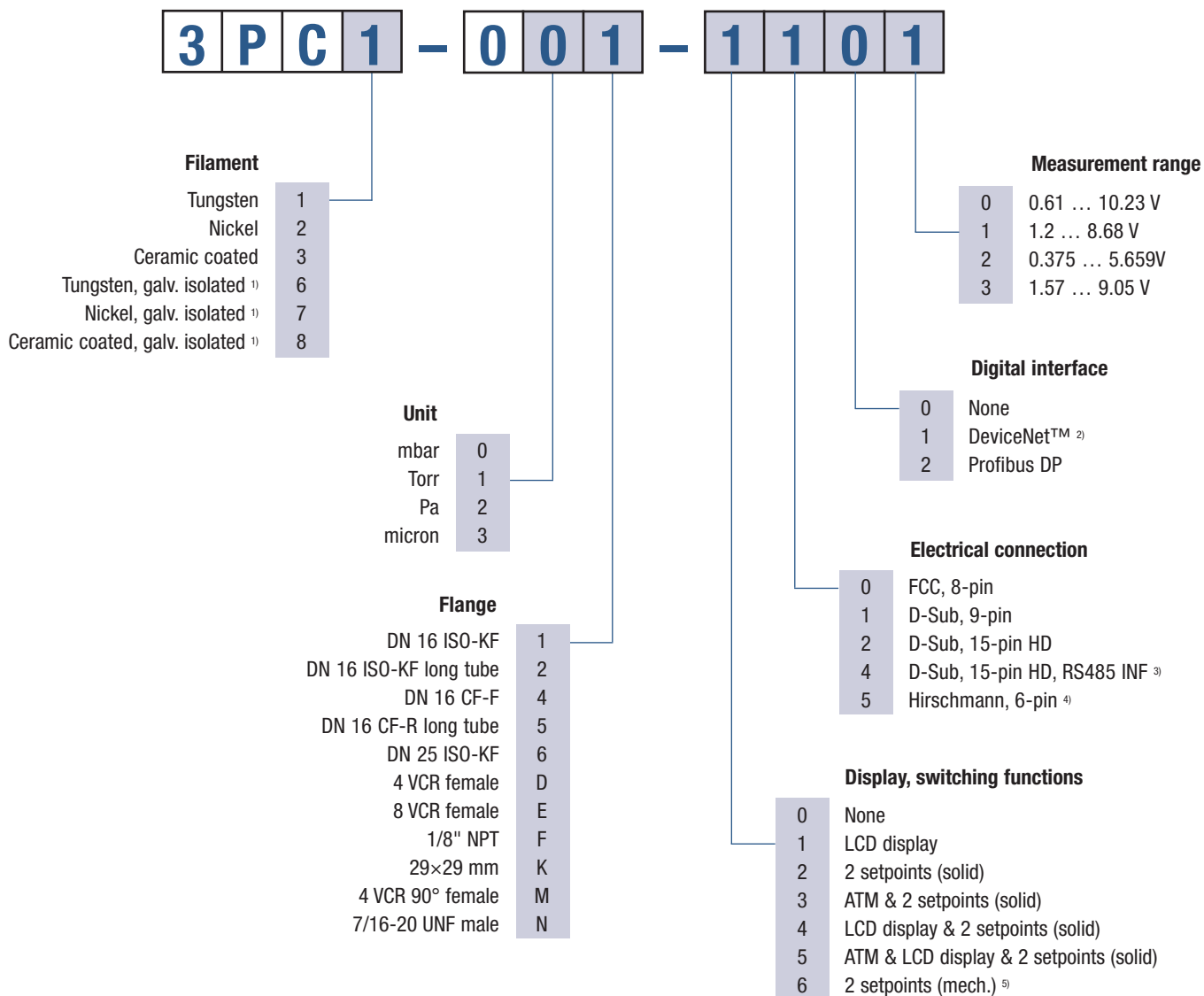

<sup>1)</sup> Only with D-Sub 9-pin connector available  
<sup>2)</sup> Only with D-Sub 9-pin connector and galvanically isolated available  
<sup>3)</sup> Only without additional digital interface available  
<sup>4)</sup> No fieldbus interface, setpoints and ATM sensor available  
<sup>5)</sup> Only with D-Sup 9-pin connector without LCD display available

**PCG550, PCG552, PCG554** (continued)

**Specifications**

Type			PCG550	PCG552	PCG554
Filament			Tungsten	Nickel	ceramic coated
Measurement range		mbar (Torr)	5×10 <sup>-5</sup> ... 1500 (3.8×10 <sup>-5</sup> ... 1125)		
Accuracy (N <sub>2</sub> )	5×10 <sup>-4</sup> ... 1×10 <sup>-3</sup> mbar	% of reading	±50		
	1×10 <sup>-3</sup> ... 100 mbar	% of reading	±15		
	100 ... 950 mbar	% of reading	±5		
	950 ... 1050 mbar	% of reading	±2.5		
Repeatability (N <sub>2</sub> )	1×10 <sup>-3</sup> ... 1100 mbar	% of reading	±2		
Admissible pressure		bar (absolute)	≤5		
Burst pressure		bar (absolute)	10		
Admissible temperature					
Operation (ambient)		°C	+10 ... +50		
Storage		°C	-20 ... +65		
Bakeout at flange		°C	≤80		
Long tube		°C	≤250		
Supply voltage		V / A DC	+15 ... +30		
Power consumption					
Without fieldbus		W	≤2.5		
DeviceNet™		W	≤3		
Profibus		W	≤3		
Output signal analog					
3PCx-0xx-xxx0		V	0 ... +10.23		
-xxx1		V	0 ... +8.68		
-xxx2		V	0 ... +5.659		
-xxx3		V	0 ... +9.05		
Measurement range					
3PCx-0xx-xxx0		V	+0.61 ... +10.23		
-xxx1		V	+1.2 ... +8.68		
-xxx2		V	+0.375 ... +5.659		
-xxx3		V	+1.57 ... +9.05		
Voltage vs. pressure					
3PCx-0xx-xxx0 / -xxx1		V / Decade	1.286		
3PCx-0xx-xxx2 / -xxx3		V / Decade	1		
Load impedance		kΩ	>10		
Setpoint relay			2		
Range (N <sub>2</sub> )		mbar	5×10 <sup>-5</sup> ... 1500		
Relay contact			n.o., potential free		
Hysteresis		% of threshold	10		
Contact rating					
Solid state relays		V / A DC	≤30 / ≤0.3		
Mechanical relays		V / A DC	≤30 / ≤1		
Switching time		ms	≤30		
Interface (digital)			RS232C		
Electrical connection					
3PCx-0xx-x0xx			FCC, 8-pin		
-x1xx			D-Sub, 9-pin, male		
-x2xx			D-Sub, 15-pin HD, male		
-x4xx			D-Sub, 15-pin HD, RS485 INFICON, male		
-x5xx			Hirschmann, 6-pin		
Cable length		m (ft)	≤100 (≤330)		
RS232C operation		m (ft)	≤30 (≤100)		

(continued)

## PCG550, PCG552, PCG554 (continued)

### Specifications (concluded)

Type Filament		PCG550 Tungsten	PCG552 Nickel	PCG554 ceramic coated
Materials exposed to vacuum		W, Ni, NiFe, ceramic, SnAg, stainless steel, glass	Ni, NiFe, ceramic, SnAg, stainless steel, glass	ceramic, stainless steel
Internal volume				
DN 16 ISO-KF	cm <sup>3</sup>		4.7	
DN 16 ISO-KF long tube	cm <sup>3</sup>		14.5	
DN 16 CF-F	cm <sup>3</sup>		8	
DN 16 CF-R long tube	cm <sup>3</sup>		14	
DN 25 ISO-KF, 4 VCR	cm <sup>3</sup>		5.5	
8 VCR	cm <sup>3</sup>		7	
1/8" NPT, 7/16-20 UNF	cm <sup>3</sup>		5.2	
29×29 mm	cm <sup>3</sup>		4.9	
4 VCR 90°	cm <sup>3</sup>		7.9	
Weight				
Without fieldbus interface	g		115 ... 130	
With fieldbus interface	g		230 ... 250	
Degree of protection			IP 40	

### Specifications DeviceNet™

Protocol		DeviceNet™, group 2 slave only
Data rate switch	kBaud	125, 250, 500 or network programmable
Cable length		
125 kbps	m (ft)	500 (1650)
250 kbps	m (ft)	250 (825)
500 kbps	m (ft)	100 (330)
MAC ID		2 switches (address 00 - 63) or network programmable
Digital functions		read pressure, select units: Torr, mbar, Pa, micron, counts monitor gauge status, detailed alarm and warning information, safe state allows definition of behavior in case of error
Specification		DeviceNet™ "Vacuum Gauge Device Profile"
Device type		"CG" for combination gauge
I / O slave messaging		polling only
Supply voltage for DeviceNet™		
3PC1- / 3PC2- / 3PC3-0xx-xxxx	V / A DC	+15 ... +30
Power consumption		
3PC1- / 3PC2- / 3PC3-0xx-xxxx	W	≤3
Connector for DeviceNet		Micro-Style, 5-pin, male

### Specifications Profibus DP

Baud rates	kBaud MBaud	9.6 / 19.2 / 93.75 / 187.5 / 500 1.5 / 12
Address		2 switches (address 00 - 127) or network programmable
Digital functions		read pressure, select units: Torr, mbar, Pa, micron, counts monitor gauge status, detailed alarm and warning information, safe state allows definition of behavior in case of error
Connector for Profibus DP		D-Sub, 9-pin, female

## PCG550, PCG552, PCG554 (continued)

### Specifications RS485C

Baud rates	kBaud	9.6 / 19.2 / 38.4 / 57.6
Address		2 switches (address 00 - 127) or network programmable
Digital functions		read pressure, select units: Torr, mbar, Pa, micron, counts monitor gauge status, detailed alarm and warning information, safe state allows definition of behavior in case of error
Connector for RS485		D-Sub, 15-pin HD, male

### Spare Parts

Type		PCG550 Tungsten	PCG552 Nickel	PCG554 ceramic coated
Replacement sensor	DN 16 ISO-KF	<b>357-925</b>	<b>357-936</b>	<b>357-947</b>
	DN 16 ISO-KF long tube	<b>357-926</b>	<b>357-937</b>	<b>357-948</b>
	DN 16 CF-F	<b>357-927</b>	<b>357-938</b>	<b>357-949</b>
	DN 16 CF-R long tube	<b>357-928</b>	<b>357-939</b>	<b>357-950</b>
	DN 25 ISO-KF	<b>357-929</b>	<b>357-940</b>	<b>357-951</b>
	4 VCR female	<b>357-932</b>	<b>357-943</b>	<b>357-954</b>
	8 VCR female	<b>357-931</b>	<b>357-942</b>	<b>357-953</b>
	1/8" NPT	<b>357-930</b>	<b>357-941</b>	<b>357-952</b>
	29×29 mm	<b>357-934</b>	<b>357-945</b>	<b>357-956</b>
	4 VCR 90° female	<b>357-935</b>	<b>357-946</b>	<b>357-957</b>
	7/16-20 UNF male	<b>357-933</b>	<b>357-944</b>	<b>357-955</b>

### Accessories

Centering ring with filter (DN 16 ISO-KF)	<b>211-097</b>
Diagnostic <sup>1)</sup> : Communication adapter (2 m) for PC RS232C serial port	<b>303-333</b>

<sup>1)</sup> Software to run the diagnostic functions on Windows NT, XP can be downloaded from our website.

# PCG550, PCG552, PCG554 (continued)

## Dimensions, Internal Volume, Weight

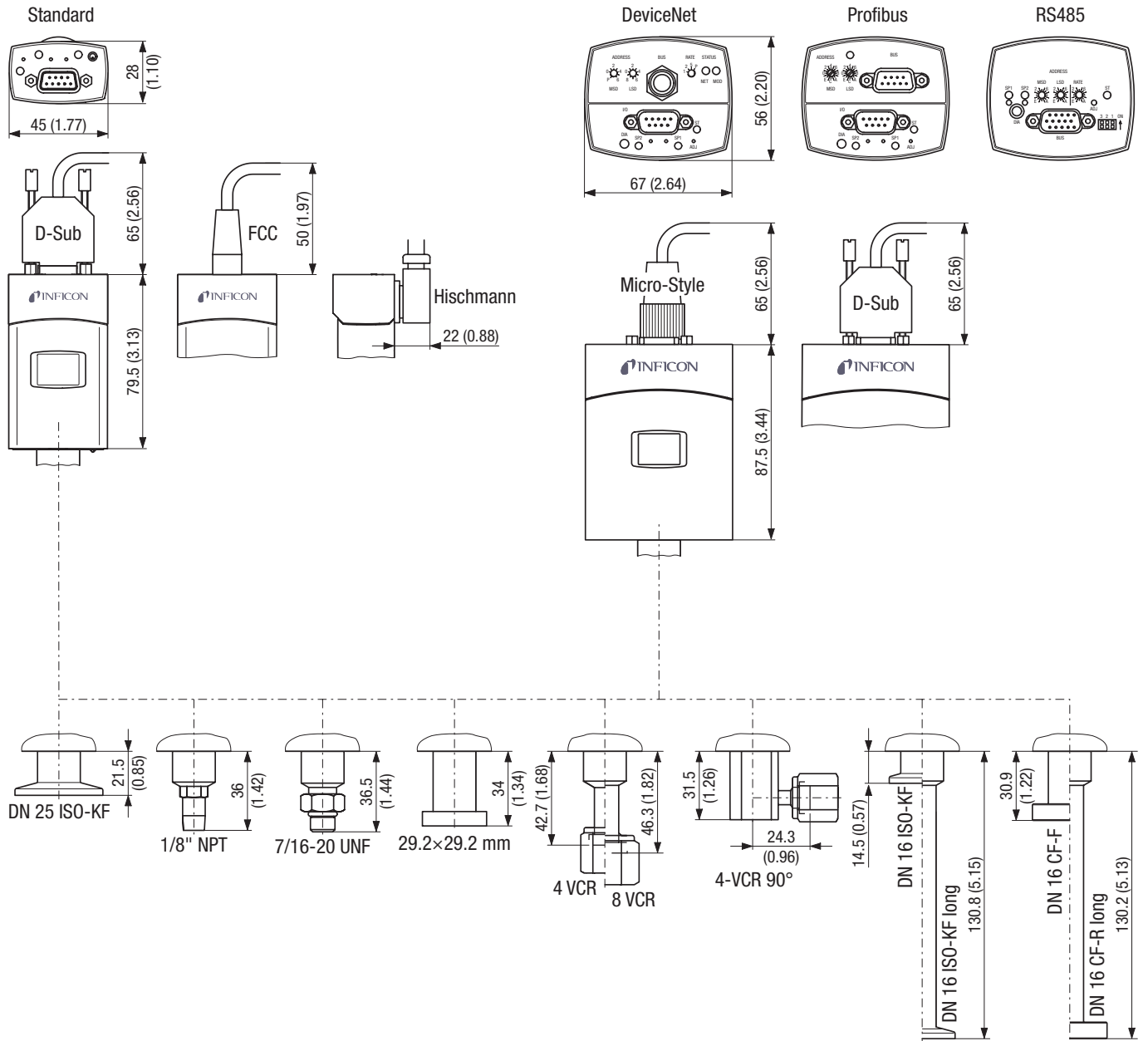



# Penning Gauge

## PEG100

The INFICON Penning Gauge PEG100 provides reliable high vacuum measurements. The rugged Penning cold cathode sensor has no filament to burn out. Due to titanium cathode plates and the reduced high voltage after plasma ignition, the gauge can be operated also in sputtering applications. The fieldbus options, in addition to the logarithmic analog output signal, allow easy integration into vacuum systems using Profibus DP or DeviceNet protocols.

### ADVANTAGES

- Wide measurement range from  $5 \times 10^{-9}$  to  $1 \times 10^{-2}$  mbar ( $7.5 \times 10^{-10}$  to  $7.5 \times 10^{-3}$  Torr)
- All-metal cold cathode sensor (Penning) with ceramic feedthrough
- Innovative electrode geometry provides excellent ignition properties
- Decreased high voltage after plasma ignition and titanium cathode plates reduce risk of contamination, even during sputtering operations with argon
- The anode ring and the titanium cathode can be cleaned or replaced easily
- Minimal magnetic field intensity adjacent to gauge
- LED indicator for power on and plasma ignited
- Logarithmic analog output signal
- Fieldbus interface (Profibus DB, DeviceNet) for easy integration into vacuum systems using network communications

### APPLICATIONS

- High vacuum pressure monitoring
- Evaporation and sputtering systems
- General vacuum measurement and control in the fine and high vacuum range



### Ordering Information

Type	PEG100	PEG100-D with DeviceNet™	PEG100-P with Profibus DP™
DN 25 ISO-KF	351-000	351-003	351-005
DN 40 CF-R	351-002	351-004	—
Replacement cathode plates, titanium Set of 5 pieces	351-490	351-490	351-490

## PEG100 (continued)

### Specifications

			PEG100
Measurement range	mbar		$1 \times 10^{-9}$ to $1 \times 10^{-2}$
	Torr		$7.5 \times 10^{-10}$ to $7.5 \times 10^{-3}$
Accuracy	$10^{-8}$ to $10^{-4}$ mbar	% of reading	±30
Pressure, max. absolute		bar	10
Temperature			
Operation (ambient)		°C	+10 to +50
Storage		°C	-20 to +75
Bakeout			
without electronics		°C	350
with electronics, at flange		°C	70
Supply			
Voltage		V DC	14.5 to 36
Consumption, max.		W	<2
Output signal analog			
Measurement range		V	0 to 10.6
Relation voltage / pressure		V / Decade	1.333
Connector			FCC 68, female, 8 pin (shielded)
Cable length, max. (analog)		m (ft)	100 (330)
Materials exposed to vacuum			
Internal volume		cm <sup>3</sup> (inch) <sup>3</sup>	21 (1.28)
Weight, approx.		g	500
Protection type			IP40

### Specifications

			PEG100-D DeviceNet™
Device type			generic
Explicit peer to peer messaging			no
I / O peer to peer messaging			no
Configuration consistency value			no
Faulted node recovery			no
Baud rates		kBaud	125 / 250 / 500
Master / Scanner			no
I / O slave messaging			
Bit Strobe			yes
Polling			yes
Cyclic			yes
Change of State (COS)			yes
Supply for DeviceNet		V DC	11 to 25
Connector for DeviceNet			Phoenix Combicon, 5 pin

### Specifications

			PEG100-P Profibus DP™
Supported baud rates (auto detection)		kBaud	9.6 / 19.2 / 93.75 / 187.5 / 500 / 1500
Expanded user parameter data		Bytes	5
Configuring			
Number of input and output data			2
Sync-Mode and Freeze-Mode			Yes
Connector			D-sub, 9 pin

## PEG100 (continued)

### Dimensions

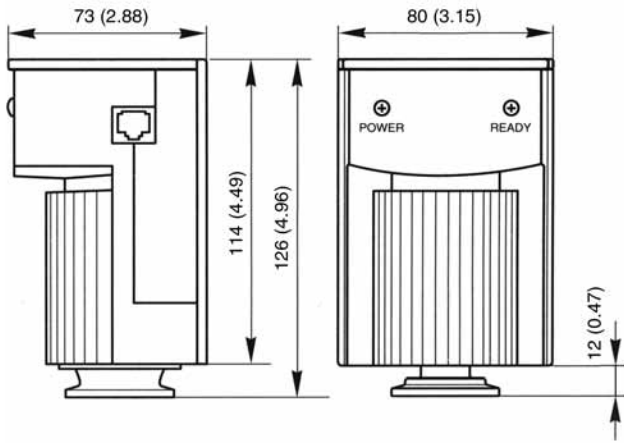

# Inverted Magnetron Pirani Gauge

## MPG400/401

The INFICON Inverted Magnetron Pirani Gauges, MPG400 and MPG401, measure from  $5 \times 10^{-9}$  mbar to atmosphere ( $3.8 \times 10^{-9}$  Torr to atmosphere). Combining technologies into one single compact unit with one logarithmic analog output signal significantly reduces the complexity of installation, setup and integration.



### ADVANTAGES

- Combination gauge – Inverted Magnetron & Pirani
- Wide measurement range from  $5 \times 10^{-9}$  mbar to atmosphere
- No filament to burn out
- Excellent ignition properties
- Easy to clean
- FPM or metal-sealed feedthrough
- LED indicator for high voltage on
- Logarithmic analog output signal

### APPLICATIONS

- High vacuum pressure monitoring
- Base pressure for evaporation and sputtering systems
- General vacuum measurement and control in the medium and high vacuum range

### Ordering Information

Type	MPG400 FPM sealed	MPG401 metal-sealed
DN 25 ISO-KF	351-010	351-020
DN 40 ISO-KF	351-011	351-021
DN 40 CF-F	351-012	351-022

### Accessories

Type	MPG400 FPM sealed	MPG401 metal-sealed
Magnetic shield	351-023	351-023

## MPG400/401 – continued

## Specifications

		MPG400 FPM sealed	MPG401 metal-sealed
Measurement range (air, N <sub>2</sub> )	mbar (Torr)	5 x 10 <sup>-9</sup> ... 1000	(3.8 x 10 <sup>-9</sup> ... 760)
Accuracy (N <sub>2</sub> )	1 x 10 <sup>-8</sup> ... 100 mbar	% of reading	≈±30%
Repeatability	1 x 10 <sup>-8</sup> ... 100 mbar	% of reading	≈±5%
Mounting orientation			any
Admissible pressure	bar (absolute)		≤10 (limited to inert gases)
Admissible temperature			
Operation (ambient)	°C		+5 ... +55
Storage	°C		-40 ... +65
Bake-out <sup>1)</sup>	°C		150
Filament temperature (Pirani)	°C		120
Supply voltage			
At gauge	V DC		+15 ... +30
At supply unit with max. cable length <sup>2)</sup>	V DC		+16 ... +30
Ripple	V <sub>pp</sub>		≤1
Power consumption	W		≤2
Fuse to be connected	AT		≤1
Output signal (measurement signal)			
Voltage range	V		0 ... +10.5
Measurement range	V		+1.82 ... +8.6
Voltage vs. pressure			logarithmic, 0.6 V/decade
Error signal	V		<0.5 (no supply)
	V		>9.5 (Pirani sensor, filament rupture)
Output impedance	Ω		2 x 10
Minimum loaded impedance	kΩ		10, short-circuit proof
Response time	p > 10 <sup>-6</sup> mbar	ms	<10
	p = 10 <sup>-8</sup> mbar	ms	≈1000
Identification gauge	kΩ		85, referenced to supply common
Status			
Pirani-only mode		V	0 (low)
Combined Pirani / cold cathode mode	V		15 ... 30 (high)
LED	LED green		high voltage on
Electrical connection			FCC 68 appliance connector, 8 poles, female
Sensor cable			8 poles plus shielding
Cable length	m		≤50 (8 x 0.14 mm <sup>2</sup> )
Operating voltage	kV		≤3.3
Operating current	μA		≤500
Materials exposed to vacuum		stainless steel, Al <sub>2</sub> O <sub>3</sub> , FPM75, Mo, Ni, Au, W	stainless steel, Al <sub>2</sub> O <sub>3</sub> , Ag, Cu, Sn Mo, Ni, Au, W
Internal volume	cm <sup>3</sup>		≈20
Weight			
DN 25 ISO-KF	g	≈700	≈730
DN 40 ISO-KF	g	≈720	≈750
DN 40 CF-F	g	≈980	≈1010
Protection category			IP 40
Standards			EN 61000-6-2, EN 61000-6-3, EN 61010-1

<sup>1)</sup> Without electronics and magnetic shielding.

<sup>2)</sup> The minimum voltage of the supply unit must be increased proportionally to the length of the sensor cable.

**Dimensions**

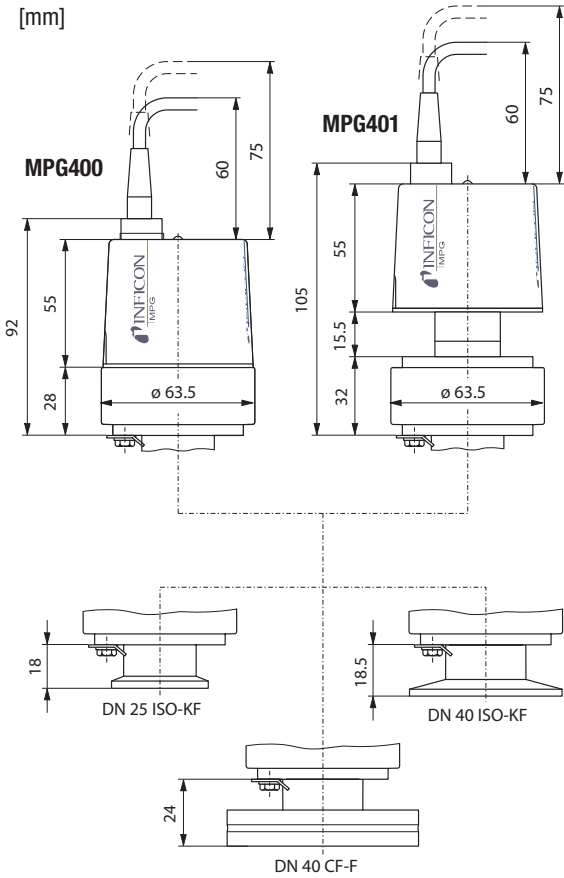

**Spare Parts**

Type	MPG400 FPM sealed	MPG401 metal-sealed
Maintenance kit includes: support/centering ring seals ignition aid	<b>351-999</b>	<b>351-997</b>
Repair kit includes: Pirani element anode anode extension <sup>1)</sup> Cu seal <sup>1)</sup> screw fitting <sup>1)</sup> support/centering ring seals ignition aid	<b>351-998</b>	<b>351-996</b>
Ignition aid kit includes: ignition aid	<b>351-995</b>	<b>351-995</b>
Mounting tool for ignition aid	<b>351-994</b>	<b>351-994</b>

<sup>1)</sup> MPG401 only

# Vacuum Gauge Controllers

## VGC401, VGC402, VGC403

### Your complete solution for process measurement and control.

Compatible with all INFICON active gauges, the VGC400 series of controllers can monitor the entire pressure range from  $10^{-10}$  to 1500 mbar ( $10^{-10}$  to 1125 Torr) and the setpoint status.

### Advantages

- Automatic identification of the connected INFICON gauges
- User selectable measurement unit (mbar, Torr, Pascal, micron)
- High resolution – 16 bit A/D converter
- Up to six adjustable setpoints with adjustable hysteresis may be assigned to any channel
- Compliance & standards: CE, ETL, RoHS
- Programmable 0 to 10 V chart recorder output with logarithmic / linear characteristics for each gauge or gauge combination (VGC402/403 only)
- Firmware upgrades available on-line are easily downloaded via the RS232 interface
- Versatile, compact bench-top model design can easily be mounted in a panel or 19" rack
- Wide range power supply 90 to 250V, 50 to 60Hz

VGC401



VGC402



VGC403



### Ordering Information

Type	VGC401	VGC402	VGC403
Vacuum Gauge Controller	<b>398-010</b>	<b>398-020</b>	<b>398-021</b>
Adapter for rack mount 2HE / 3HE	<b>398-499</b>	–	–

### Accessories

Gauges	PCG, PEG, PSG, MPG	BAG, BCG, BPG, HPG CDG	CDG (unheated)
Signal read out / communication	analog	digital analog possible	analog
Connector	FCC / FCC	D-Sub / D-Sub	FCC / D-Sub

#### Cable to VGC401/402/403 in m (ft)

3 (9.9)	<b>398-500</b>	<b>398-520</b>	<b>398-540</b>
5 (16.5)	<b>398-501</b>	<b>398-521</b>	<b>398-541</b>
10 (33.0)	<b>398-502</b>	<b>398-522</b>	<b>398-542</b>
15 (49.5)	<b>398-503</b>	<b>398-523</b>	<b>398-543</b>
20 (66.0)	<b>398-504</b>	<b>398-524</b>	<b>398-544</b>
30 (99.0)	<b>398-505</b>	<b>398-525</b>	<b>398-545</b>

other lengths on request

# VGC401, VGC402, VGC403 (continued)

## Specifications

Type		VGC401	VGC402	VGC403
Measurement channels		1	2	3
Display		LED	LCD	LCD
Range	mbar (Torr)	$2 \times 10^{-10} \dots 1500$ ( $1.5 \times 10^{-10} \dots 1125$ )	$5 \times 10^{-10} \dots 1500$ ( $3.75 \times 10^{-10} \dots 1125$ )	$5 \times 10^{-10} \dots 1500$ ( $3.75 \times 10^{-10} \dots 1125$ )
Rate	1/s	10	10	10
A/D converter	bit	16	16	16
Connectable gauges with display range				
CDG (A/D)	Torr		$1 \times 10^{-3} \times \text{FS} \dots 1 \times \text{FS}$	
PCG400	mbar (Torr)		$5 \times 10^{-4} \dots 1500$ ( $3.75 \times 10^{-4} \dots 1125$ )	
PSG	mbar (Torr)		$5 \times 10^{-4} \dots 1000$ ( $3.75 \times 10^{-4} \dots 750$ )	
MPG	mbar (Torr)		$5 \times 10^{-9} \dots 1000$ ( $3.75 \times 10^{-9} \dots 750$ )	
PEG	mbar (Torr)		$1 \times 10^{-9} \dots 1 \times 10^{-2}$ ( $7.5 \times 10^{-10} \dots 7.5 \times 10^{-3}$ )	
BCG	mbar (Torr)		$5 \times 10^{-10} \dots 1500$ ( $3.75 \times 10^{-10} \dots 1125$ )	
BPG	mbar (Torr)		$5 \times 10^{-10} \dots 1000$ ( $3.75 \times 10^{-10} \dots 750$ )	
HPG	mbar (Torr)		$2 \times 10^{-6} \dots 1000$ ( $1.5 \times 10^{-6} \dots 750$ )	
BAG	mbar (Torr)	$2 \times 10^{-10} \dots 1 \times 10^{-1}$ ( $1.5 \times 10^{-10} \dots 7.5 \times 10^{-2}$ )	–	–
Measurement unit (selectable)		mbar, Torr, Pascal, micron		
Setpoints				
Setpoint relays		1	4	6
Channel assignment		1	1 or 2	1/2 or 3
Adjustment range		Sensor dependent		
Hysteresis		adjustable		
Relay contact		potential free change over contact		
Contact rating	V AC / A V DC / A	30 / 2 60 / 1	30 / 1 60 / 0.5	30 / 1 60 / 0.5
Connector		D-Sub, 9 pin, male	D-Sub, 25 pin, female	D-Sub, 25 pin, female
Analog output				
Range		0 ... 10.3 Volt, sensor analog output signal		
Programmable analog output		–	1	1
Connector		D-Sub, 9 pin, male	D-Sub, 9 pin, male	D-Sub, 9 pin, male
Interface (digital)				
Connector		RS 232 C D-Sub, 9 pin, female	RS 232 C D-Sub, 9 pin, female	RS 232 C D-Sub, 9 pin, female
Power				
Supply	V	90 ... 250	90 ... 250	90 ... 250
Frequency	Hz	50 ... 60	50 ... 60	50 ... 60
Consumption	W	≤ 30	≤ 45	≤ 65
Temperature				
Operation (ambient)	°C	5 ... 50	5 ... 50	5 ... 50

## Dimensions

VGC401

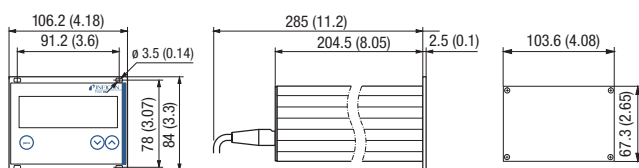

VGC402 / VGC403

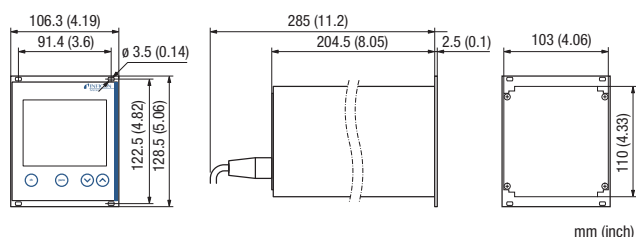

mm (inch)



# Pirani Gauge Display

## PGD400

The INFICON Pirani Gauge Display PGD400 in combination with the INFICON Pirani Standard Gauge PSG500 is providing a cost effective pressure monitoring solution.

### Advantages

- User selectable measurement unit (Pa, mbar or Torr)
- Compact bench top model design can be easily mounted in a panel or 19" rack
- 0 to 10 V output signal from the gauge is available for use in PLC or with a chart recorder
- One free adjustable set point
- Automatic gauge connection and filament detection
- CE / UL certified



### Applications

- Fore vacuum pressure measurement
- Pressure measurement on evacuation/filling stations for RAC applications
- Pressure measurement in light bulb production lines
- General vacuum measurement and control in the medium and rough vacuum range

### Ordering Information

Type	PGD400	PSG500
Pirani Gauge Display	<b>398-800</b>	
Pirani Standard Gauge <sup>1)</sup>	–	<b>350-060</b>

<sup>1)</sup> Other Pirani Standard Gauges on request

### Accessories

Sensor cable <sup>1)</sup>	1.3 m (4.27ft)	<b>398-498</b>
Seal with centering ring and filter	DN 16 ISO-KF	<b>211-090</b>
Adapter for rackmount 2HE / 3HE		<b>398-499</b>

<sup>1)</sup> Other lengths on request

## PGD400 (continued)

### Specifications

Measurement channels		1 (PSG5xx only)
Display		LED
Range	Pa	$5 \times 10^{-2} \dots 1 \times 10^5$
	mbar	$5 \times 10^{-4} \dots 1 \times 10^3$
Measurement rate	1/s	30
Measurement unit (selectable)		Pascal, mbar, Torr
Setpoint		
Setpoint relay		1
Adjustment range		$1 \times 10^{-3} \dots 500$
Hysteresis		$\geq 10\%$ of measurement value
Relay contact		floating changeover contact
Contact rating	V AC / A	50 / 5
Connector		D-Sub, 9 pin, male
Analog output	V	0 ... 10.3, sensor output signal
Power		
Supply	V AC	100 ... 240
Frequency	Hz	50 ... 60
Consumption	VA	$\leq 30$
Temperature		
Operation (ambiance)	°C	+5 ... +50
Storage	°C	-20 ... 60
Relative humidity		$\leq 80\%$ up to +31 °C decreasing to 50% at +40 °C
Degree of protection		IP20
Weight	kg	0.85

### Dimensions

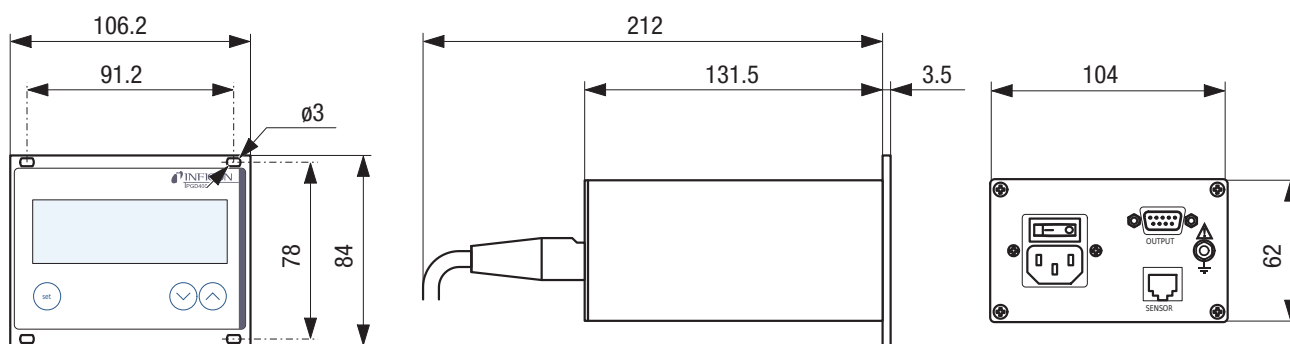

# Vacuum Switch

## VSA100A

The pressure switch VSA100A is used as a safety switch in vacuum systems. For example, to automatically interrupt the gas supply when venting vacuum systems with a purge gas at a pressure of 6 mbar below atmospheric pressure.

At a differential pressure of 6 mbar resp. return switching pressure of 3 mbar below atmospheric pressure, an elastic diaphragm actuates a changeover contact which in turn may be used to switch directly any ancillary equipment.

The electrical connections are protected by a plastic cover.



### Advantages

- Reliable and budget-priced vacuum switch
- Long service life
- Rugged design
- Easy to integrate
- IP 44 protection
- Can be connected to a programmable control

### Applications

- Control of load lock chambers
- Safety shutdown of vacuum systems

### Ordering Information

Type	VSA100-A
DN 16 ISO-KF, complete with 3 m (9.9 ft) cable	399-001

## VSA100A - continued

### Specifications

Switching pressure	mbar	6 ±2 (below atmosphere)
Back switching	mbar	3 ±2 (below atmosphere)
Operating pressure (absolute)	bar	<2
Helium permeation	mbar l/s	<10 <sup>-6</sup>
Leak rate	mbar l/s	<5 x 10 <sup>-8</sup>
Temperature		
Operation	°C	0 ... +85
Storage	°C	-20 ... +85
Switching contacts (gold plated)		Change over contact
Voltage max.	VDC/VAC	24/24
Current max.	mA	30 (24 VDC) / 100 (24 VAC)
Load min.	mA	1
Electrical connector		Cable, bare wire
Cable length, standard	m (ft)	3 (9.9)
Vacuum connection		DN 16 ISO-KF
Protective type		IP 44
Mounting orientation		vertical (standing)
Internal volume	cm <sup>3</sup> (inch <sup>3</sup> )	2 (0.122)
Materials exposed to vacuum		Stainless steel 1.4305, EPDM, PTFE (Teflon)
Weight	g	315

**Technical Note:** Due to the diaphragm material used (EPDM), the Vacuum Switch VSA100A is not suited for applications in which the process gas contains large quantities of helium. The leak rate of the diaphragm for helium is >10<sup>-6</sup> mbar l/s.

### Dimensions

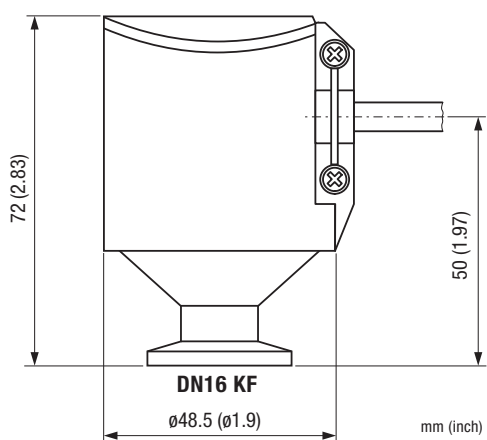

# Vacuum Switch

## VSC150A

The pressure switch VSA100A is used as a safety switch in vacuum systems. For example, to automatically interrupt the gas supply when venting vacuum systems with a purge gas at a pressure of 6 mbar below atmospheric pressure.

At a differential pressure of 6 mbar, and a return switching pressure of 3 mbar below atmospheric pressure, an elastic diaphragm actuates a changeover contact which in turn may be used to switch directly any ancillary equipment.

The electrical connections are protected by a plastic cover.



### Advantages

- High switching accuracy ( $\pm 0.1$  mbar)
- Stable long term operating characteristics
- Rugged, corrosion protected design
- Increased switching capability when using switching amplifier
- Switching contacts (normally closed) in the reference chamber and thus protected against process media
- Adapter available for differential pressure measurement

### Applications

- Pressure switch or differential pressure switch to control valves, pumps, power supplies
- Load lock chambers
- Process chambers

### Ordering Information

<b>Type</b>	<b>VSC150</b>
DN 16 ISO-KF	<b>399-005</b>

### Accessories

SV Switching Amplifier	<b>399-008</b>
Pressure Switch Adjustment	<b>399-006</b>
Differential Pressure Adapter	<b>399-007</b>

## VSC150A - continued

## Specifications

			VSC150 Vacuum Switch
Switching range	mbar		0.5 ... 2000
Response sensitivity	mbar		0.1
Overload limit	mbar		3000
Switching hysteresis	mbar		0.5
Temperature			
Operation (ambient)	°C		5 ... 90
Storage	°C		-20 ... 70
Bakeout (max. 8 h)	°C		120
Coefficient of switch point	%/K of switching value		0.4
Vacuum connection			DN 16 ISO-KF
Electrical connection			Protected plug (DIN 43650)
Switch			n.c.
Switching voltage	V		24
Switching current	mA		10
Contact resistance	Ω		1
Protection category			IP 65
Materials in contact with the medium			
Sensing volume			Stainless steel 1.4301, 1.4401, 1.4310, 1.3541, FPM75
Reference volume			Stainless steel 1.4301, 1.4401, 1.3541, glass, gold
Sensing volume <sup>1)</sup>	cm <sup>3</sup>		≈4
Reference volume	cm <sup>3</sup>		≈20
Weight	kg		1.3

<sup>1)</sup> Including connection port.

## Specifications

			SV Switching Amplifier
Mains supply (selectable)	V		110 ... 130, 220 ... 240
Mains frequency	Hz		50 / 60
Power consumption	VA		3
Output relay			
Switching voltage	V		250
Switching current	A		5
Switching capacity	VA		500
Response time	ms		30
Release time	ms		7
Control circuit	V / mA		24 / 10
Operation temperature	°C		5 ... 50
Weight	kg		0.36

# VSC150A - continued

## Dimensions

### VSC150 Vacuum Switch

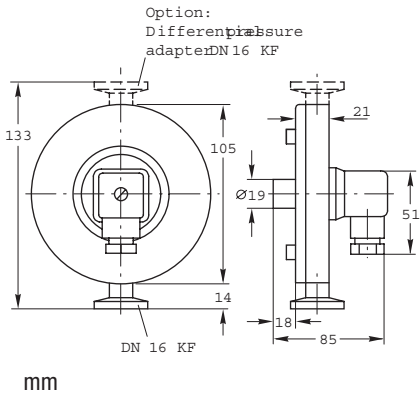

### SV Switching Amplifier

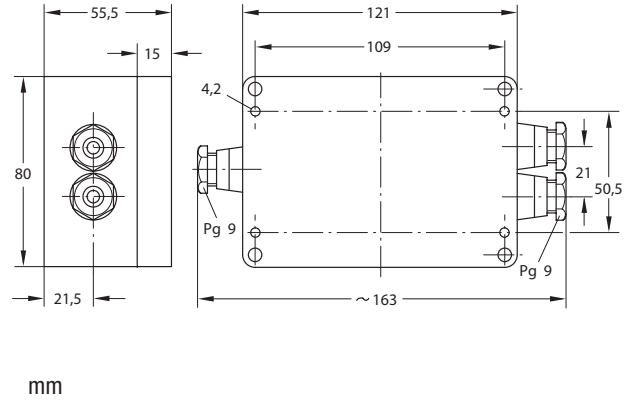

# Calibration Service

## Vacuum Gauges

INFICON offers calibration services for vacuum gauges. A DKD calibration certificate or a factory calibration certificate can be issued. Calibration to other standards (e.g. NIST) is available upon request.

### Advantages

- Known deviation to calibration standards
- Controlled quality over time

### Applications

- Reference to standard is required
- Reference for customer in-house calibration service of vacuum gauges

### DKD CALIBRATION

The German Calibration Service (DKD) ensures traceability of industrial measurements and testing to national calibration standards. It is run jointly by the Federal Institution for Physics and Technology (PTB), the Industry, the Federal Minister for Economics and the Western European Metrology Club (WEMC).

The transfer standards employed in the DKD calibration facility are checked regularly (recalibrated) by the PTB.

### FACTORY CALIBRATION

Factory calibrations are run with standards which have not been calibrated directly at the PTB; instead the transfer standards of the DKD calibration service are used. Thus traceability to national standards is ensured in both cases.

### OTHER CALIBRATIONS

NIST Calibration available upon request. Call for pricing and availability.

### Ordering Information

Calibration Service	DKD Calibration	Factory Calibration
Calibration range		
to 10 <sup>-3</sup> mbar / Torr	<b>398-900</b>	<b>398-910</b>
to 10 <sup>-5</sup> mbar / Torr	<b>398-901</b>	<b>398-911</b>
to 10 <sup>-7</sup> mbar / Torr	<b>398-902</b>	<b>398-912</b>





---

# **Vacuum Feedthroughs**

---

## VACUUM FEEDTHROUGHS

### Rotary Feedthroughs ISO-KF / ISO-K

FRH DN 16 - DN 63 .....	B1
-------------------------	----

### Rotary Feedthroughs CF

FRU DN 16 - DN 40 .....	B3
-------------------------	----

### Rotary/Linear Motion Feedthroughs ISO-KF

FCH DN 16 - DN 40 .....	B5
-------------------------	----

### Linear Motion Feedthroughs CF

FPU DN 16 - DN 40 .....	B7
-------------------------	----

### Electrical Feedthroughs

DN 16 ISO-KF .....	B9
DN 40 ISO KF .....	B11
DN 16 CF .....	B13
DN 40 CF .....	B15
DN 40 ISO KF .....	B17

### Coaxial Feedthroughs ISO-KF / CF-F

BNC / MHV DN 16 - 40 .....	B19
----------------------------	-----

### Vacuum Feedthroughs

METAL-CERAMIC CONNECTIONS .....	B21
---------------------------------	-----

### Liquid Feedthroughs ISO-KF / CF-F

DN 40 .....	B23
-------------	-----

### Viewports

DN 25 - DN 50 ISO-KF .....	B25
DN 63 - DN 160 ISO-K .....	B27
DN 16 - DN 160 CF .....	B29
DN 63 - DN 160 ISO-F .....	B31

### Vacuum Feedthroughs

VACUUM BALL BEARINGS .....	B33
LUBRICANTS AND SEALING MATERIALS .....	B35

# Rotary Feedthroughs ISO-KF / ISO-K

## FRH DN 16 – DN 63

### Properties

- For transmitting high torque
- With FPM shaft seal and ball bearings



### Selection Data

Vacuum connection	DN 16 ISO-KF	DN 25 ISO-KF	DN 40 ISO-KF	DN 63 ISO-K	
Feedthrough/seal	FPM	FPM	FPM	FPM	
Shaft measure	mm	Ø5	Ø8	Ø12	Ø20

### Ordering Information

Type	FRH016-H	FRH025-H	FRH040-H	FRH063-H
Part No.	214-300	214-302	214-304	214-306 <sup>2)</sup>

### Specifications

Transferable torque	Nm	1.5	6	25	100
Rotational speed <sup>1)</sup>	rpm	1500	1000	750	500
Idling torque under vacuum	Ncm	≤ 3	≤ 4	≤ 5	≤ 10
Starting torque under vacuum	Ncm	≤ 6	≤ 8	≤ 10	≤ 20
Shaft load vacuum sided					
Radial force	N	60	150	250	500
Axial force	N	30	50	60	100
Service life	Revolutions	20 000 000	20 000 000	20 000 000	10 000 000
Tightness, static	mbar l/s	1 x 10 <sup>-9</sup>	1 x 10 <sup>-9</sup>	1 x 10 <sup>-9</sup>	1 x 10 <sup>-9</sup>
Pressure (absolute)	1 x 10 <sup>-9</sup> mbar ... 1 bar				
Operating temperature	°C	50			
Bakeout temperature	°C	110			
Materials exposed to process media	stainless steel 420/1.4021 aluminum 6063/3.2315 elastomer FPM				
Weight	kg	0.1	0.2	0.6	2

<sup>1)</sup> When a reduced service life is acceptable, the rotation can be increased by up to a factor of two

<sup>2)</sup> Centering ring / CR/aluminum Part No. 212-251 / FPM / stainless steel Part No. 212-281 not included in delivery

# FRH DN 16 – DN 63 - continued

## Dimensions

FRH016-H

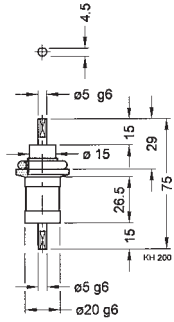

FRH025-H

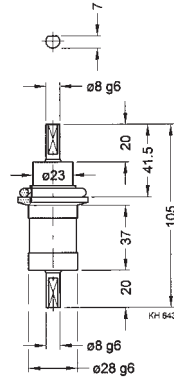

FRH040-H

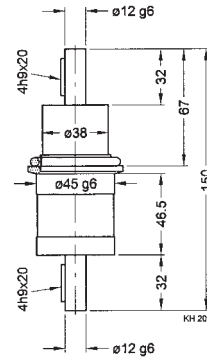

FRH063-H

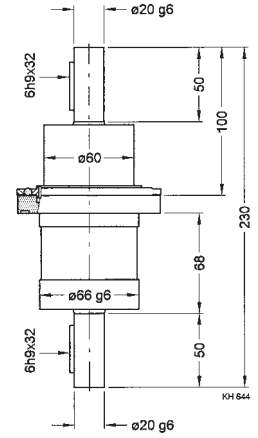

# Rotary Feedthroughs CF

## FRU DN 16 – DN 40



### Properties

- Bellow sealed
- All-metal version
- For very demanding vacuum requirements

### Selection Data

Vacuum connection	DN 16 CF-F	DN 40 CF-F	DN 40 CF-F
Feedthrough / seal	bellow	bellow	bellow
Shaft connection	mm	4	8
		8	12

### Ordering Information

Type	FRU016-H	FRU040-N	FRU040-L
Part No.	214-310	214-312	214-314

### Specifications

Transferable torque				
Dynamic	Nm	0.4	4	10
Dynamic, at 300°C	Nm	0.2	2	2
Static	Nm	0.2	3	5
Rotational speed	rpm	200	1000	500
At max. torque	rpm		500	300
Shaft load vacuum sided				
Radial force	N	10	60	100
Axial force	N	5	20	30
Service life	Revolutions	1 000 000	2 000 000	1 000 000
Scale division	Degree	10	–	–
Tightness	mbar l/s		5 x 10 <sup>-11</sup>	
Pressure (absolute)			1 x 10 <sup>-10</sup> mbar ... 2 bar	
Operating temperature	°C		300	
Bakeout temperature	°C		300	
Materials exposed to process media		304L/1.4306 304/1.4301 –/2.4360	304L/1.4306 304/1.4301 –/2.4360	304L/1.4306 304/1.4301 303/1.4305
Weight	kg	0.3	1.5	3.0

# FRU DN 16 – DN 40 - continued

## Dimensions

FRU016-H

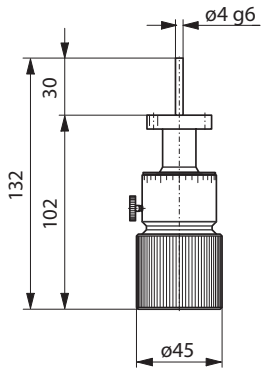

FRU040-N

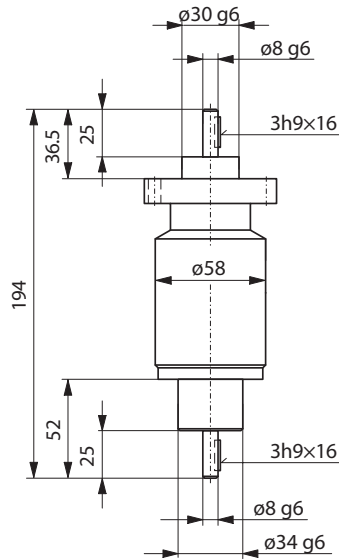

FRU040-L

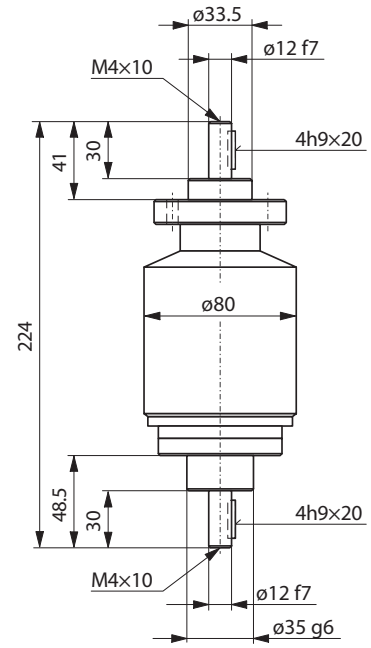

# Rotary/Linear Motion Feedthroughs ISO-KF

## FCH DN 16 – DN 40

### Properties

- Two FPM shaft seals
- Direct push/pull and rotary actuation
- With locking ring and optional anti-rotation device



### Selection Data

Vacuum connection		DN 16 ISO-KF	DN 25 ISO-KF	DN 40 ISO-KF
Feedthrough/seal		FPM	FPM	FPM
Shaft connection		M 3 / Ø 5mm	M 4 / Ø 8mm	M 6 / Ø 12mm
Travel	mm	50	100	150

### Ordering Information

Type		FCH016-H	FCH025-H	FCH040-H
Rotary/linear feedthrough	Part No.	214-320	214-322	214-324
Anti-rotation device	Part No.	214-072	214-073	214-074

### Specifications

Shaft load				
Radial force at max.travel	N	10	15	30
Torsion torque	Nm	2	8	20
Tightness, static	mbar l/s	1 x 10 <sup>-9</sup>		
Pressure (absolute)		1 x 10 <sup>-9</sup> mbar ... 1bar		
Operating temperature	°C	50		
Bakeout temperature	°C	110		
Materials exposed to process media		stainless steel 304/1.4301 aluminum 6063/3.2315		
Weight	kg	0.1	0.2	0.3

# FCH DN 16 – DN 40 - continued

## Dimensions

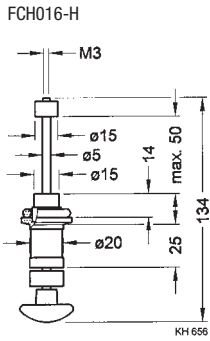

Feedthrough

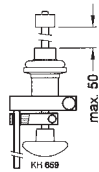

Anti-rotation device

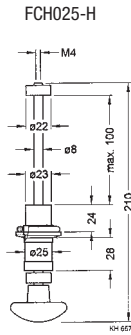

Feedthrough

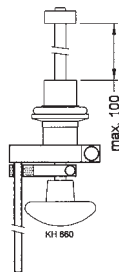

Anti-rotation device

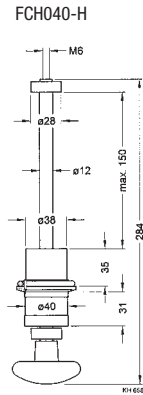

Feedthrough

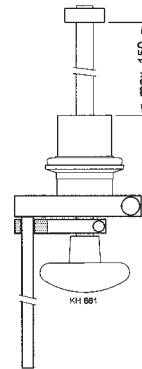

Anti-rotation device



# Linear Motion Feedthroughs CF

## FPU DN 16 – DN 40

### Properties

- With bellows for more demanding vacuum requirements
- Direct push and pull actuation
- High accuracy adjustment using micrometer screw



### Selection Data

	DN 16 CF-R	DN 40 CF-R	DN 16 CF-R	DN 40 CF-R
Vacuum connection	DN 16 CF-R	DN 40 CF-R	DN 16 CF-R	DN 40 CF-R
Feedthrough/seal	bellow	bellow	bellow	bellow
Shaft connection	M4x16 mm	M6x10 mm, Ø10 mm	M4x16 mm	M6x10mm, Ø10 mm
Actuator	manual	manual	micrometer screw	micrometer screw
Travel	mm	25	20	50

### Ordering Information

Type	FPU016-H	FPU040-H	FPU016-Z	FPU040-Z
Part No.	214-330	214-332	214-334	214-336

### Specifications

Travel per revolution	mm			0.5	1
Scale division	mm	5	10	0.01	0.005
Shaft load					
Radial force at max.	N	20	100	20	100
Axial force vacuum	N	85	140	185	440
Axial force against atm	N	100	200	200	500
Torsion torque	Nm	0.2	0.5	0.2	0.5
Tightness	mbar l/s	5 x 10 <sup>-11</sup>			
Pressure (absolute)		1 x 10 <sup>-10</sup> mbar ... 2 bar			
Bakeout temperature					
Feedthrough	°C	300	300	300	300
Micrometer screw	°C			100	100
Materials exposed to process media					
stainless steel 304L/1.4301 stainless steel 316Ti/1.4571					
Weight	kg	0.15	0.75	0.25	1

# FPU DN 16 – DN 40 - continued

## Dimensions

FPU016-H

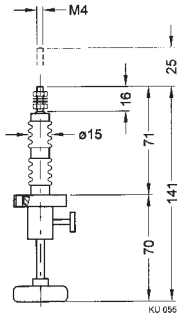

FPU040-H

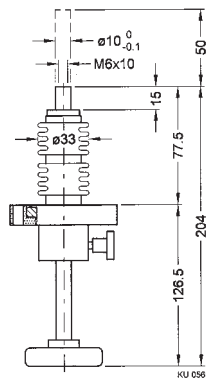

FPU016-Z

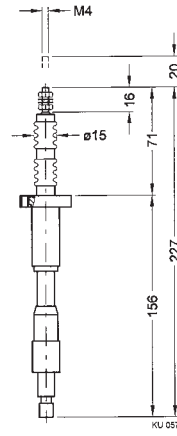

FPU040-Z

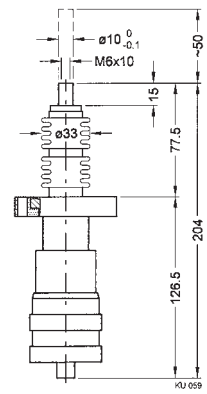

# Electrical Feedthroughs

## DN 16 ISO-KF



### Selection Data

Vacuum connection		DN 16 ISO-KF	DN 16 ISO-KF	DN 16 ISO-KF
Number of feedthroughs		4	9	9
Voltage per pole	V	50	50	50
Current per pole	A	1	2	2

### Ordering Information

Feedthrough	214-111	214-112	214-113
Connector: vacuum side	–	–	214-191
Connector: atmospheric side	214-171	214-172	214-172

### Specifications

Connection		solder connection	solder connection	connector
Vacuum side		connector	connector	connector
Atmospheric side				
Diameter of connecting wire	mm	0.6	1.2	1.2
Tightness	mbar l/s	1 x 10 <sup>-9</sup>		
Pressure (absolute)		1 x 10 <sup>-9</sup> mbar ... 2.5 bar		
Bakeout temperature (feedthrough and connector)	°C	130		
Housing		stainless steel 303/1.4305		
Insulator		PEEK / Araldite		
Seal		FPM		
Contacts (feedthrough and connector)		gold-plated bronze		

# DN 16 ISO-KF - continued

## Dimensions

214-111

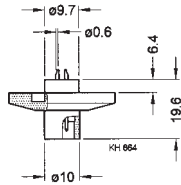

Feedthrough

214-112

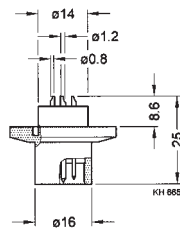

Feedthrough

214-113

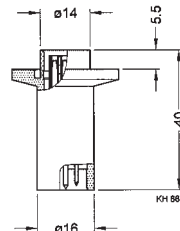

Feedthrough

214-191

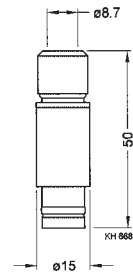

Connector:  
vacuum side

214-171

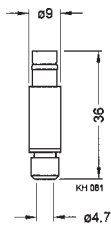

214-172

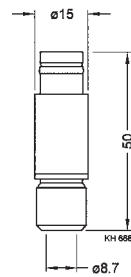

214-172

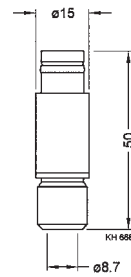

Connector:  
air side

# Electrical Feedthroughs

## DN 40 ISO KF



### Selection Data

Vacuum connection		DN 40 ISO - KF	DN 40 ISO - KF	DN 40 ISO - KF	DN 40 ISO - KF
Number of feedthroughs		7	7	4	1
Voltage per pole	V	380	380	800	6000
Current per pole	A	16	16	16	25

### Ordering Information

<b>Feedthrough</b>	<b>214-121</b>	<b>214-122</b>	<b>214-123</b>	<b>214-131</b>
<b>Connector: vacuum side</b>	–	<b>214-193</b>	<b>214-194</b>	–
<b>Connector: atmospheric</b>	<b>214-174</b>	<b>214-174</b>	<b>214-175</b>	<b>214-180</b>

### Specifications

Connection				
Vacuum side		solder connection	connector	connector
Atmospheric side		connector	connector	connector
Diameter of connecting wire	mm	1.8	1.8	2.5
Test voltage	kV/HZ	–	–	–
Pressure (absolute)		1 x 10 <sup>-8</sup> mbar ... 2.5bar		
Bakeout temperature (feedthrough and connector)	°C	130		
Housing		stainless steel 303/1.4305		
Insulator		PTFE/Araldite		
Seal		FPM		
Contact (feedthrough and connector)		gold-plated bronze	gold-plated bronze	gold-plated bronze
				nickel-plated brass

# DN 40 ISO KF - continued

## Dimensions

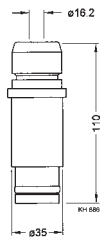
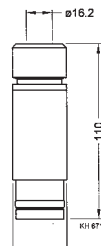
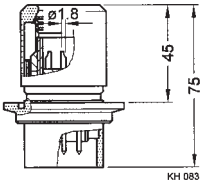
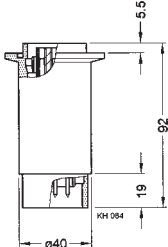
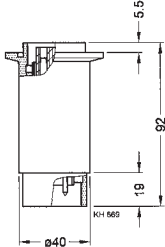
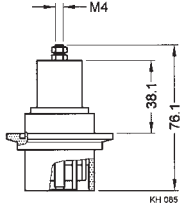
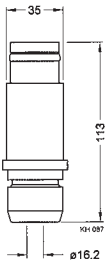
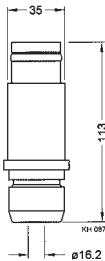
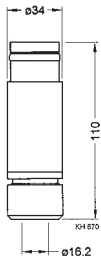
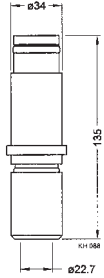
	<p>214-193</p>  <p>Connector: vacuum side</p>	<p>214-194</p>  <p>Connector: vacuum side</p>	
<p>214-121</p>  <p>Feedthrough</p>	<p>214-122</p>  <p>Feedthrough</p>	<p>214-123</p>  <p>Feedthrough</p>	<p>214-131</p>  <p>Feedthrough</p>
<p>214-174</p>  <p>Connector: air side</p>	<p>214-174</p>  <p>Connector: air side</p>	<p>214-175</p>  <p>Connector: air side</p>	<p>214-180</p>  <p>Connector: air side</p>

# Electrical Feedthroughs

## DN 16 CF

### Selection Data

Vacuum connection		DN 16 CF-F
Number of feedthroughs		1
Voltage per pole	kV	0.3
Current per pole	A	120

### Ordering Information

<b>Feedthrough</b>	<b>214-126</b>
<b>Connection piece: vacuum side</b>	<b>214-195</b>
<b>Connector: atmospheric side</b>	<b>214-176</b>

### Specifications

Bakeout temperature	°C	400
Tightness	mbar l/s	$5 \times 10^{-11}$
Pressure (absolute)		$1 \times 10^{-10}$ mbar ... 2 bar
Flange		stainless steel 304/1.4301
Conductor		OF-copper 2.0040
Insulator		aluminum oxide ceramic Al <sub>2</sub> O <sub>3</sub>
Weight		0.15
Connection piece: vacuum side		2
Current max.		100
Bakeout temperature	°C	400
Material		stainless steel 304/1.4301
Connector: atmospheric side	Pieces	2
Current max.	A	100
Insulated, for use up to	VAC/VDC	not insulated
Bakeout temperature	°C	150
Contact		silver-plated brass

# DN 16 CF - continued

## Dimensions

214-126

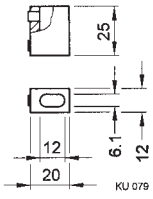

214-195

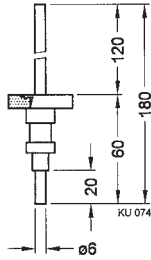

214-176

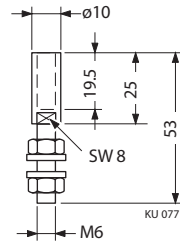



# Electrical Feedthroughs

## DN 40 CF



### Selection Data

Vacuum connection		DN 40 CF-F	DN 40 CF-F	DN 40 CF-F	DN 40 CF-F	DN 40 CF-F
Number of feedthroughs		1	1	2	4	9
Voltage per pole	kV	0.3	1	0.3	1	1
Current per pole	A	70	200/1000 <sup>1)</sup>	70	8	8

1) With water-cooling

### Ordering Information

<b>Feedthrough</b>	<b>214-136</b>	<b>214-127</b>	<b>214-128</b>	<b>214-116</b>	<b>214-117</b>
<b>Connection piece: vacuum side</b>	<b>214-195</b>	<b>214-196</b>	<b>214-195</b>	<b>214-192</b>	<b>214-198</b>
<b>Connector: atmospheric side</b>	<b>214-176</b>	<b>214-177</b>	<b>214-176</b>	<b>214-173</b>	<b>214-181</b>
<b>Connector: atm. side, H<sub>2</sub>O cooled</b>	–	<b>214-178</b>	–	–	–

### Specifications

Bakeout temperature	°C	400			
Tightness	mbar l/s	5 x 10 <sup>-11</sup>			
Pressure (absolute)		1 x 10 <sup>-10</sup> mbar ... 2 bar			
Flange		304/1.4301	304/1.4301	304/1.4301	304/1.4301
Conductor		OFC 2.0040	OFC 2.0040	OFC 2.0040	304/1.4301
Insulator		Al <sub>2</sub> O <sub>3</sub>	Al <sub>2</sub> O <sub>3</sub>	Al <sub>2</sub> O <sub>3</sub>	Al <sub>2</sub> O <sub>3</sub>
Weight		0.15	0.5	0.45	0.3
Connection piece: vacuum side		2	1	2	5
Current	A	20	1000 <sup>1)</sup>	100	12
Bakeout temperature	°C	400	400	400	400
Material		304/1.4301	2.0061	304/1.4301	304/1.4301
Connector: atmospheric side	Pieces	2	1	2	5
Current max.	A	100	250	100	25
Insulated, for use up to	VAC/VDC	not insulated	30/60	30/60	30/60
Bakeout temperature	°C	150	150	50	50
Contact		silver-plated brass	silver-plated brass	silver-plated brass	gold-plated brass

# DN 40 CF - continued

## Dimensions

214-195

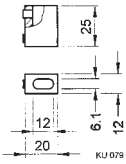

Connector vacuum side

214-196

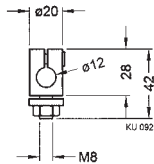

Connector vacuum side

214-195

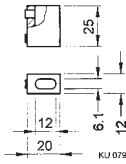

Connector vacuum side

214-192



Connector vacuum side

214-198



Connector vacuum side

214-136

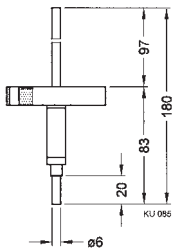

Feedthrough

214-127

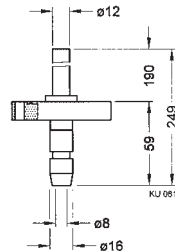

Feedthrough

214-128

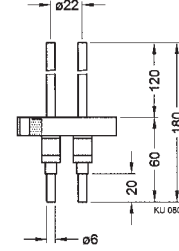

Feedthrough

214-116

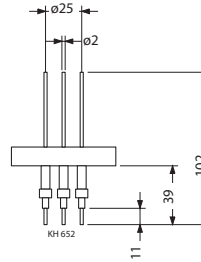

Feedthrough

214-117

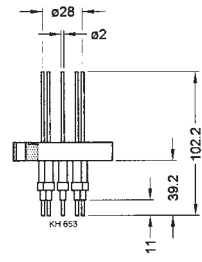

Feedthrough

214-176

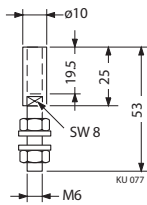

Connector air side

214-177

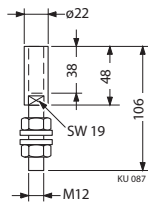

Connector air side

214-176

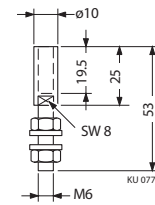

Connector air side

214-173

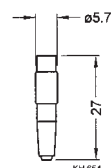

Connector air side  
With soldered joint

214-181

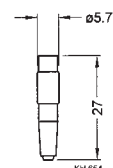

Connector air side  
With soldered joint

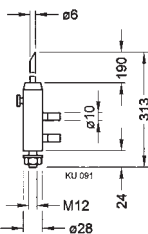

With water-proof <sup>1)</sup>		
Current max.	A	1000
Not insulated, for use up to		24
Bakeout temperature	°C	120
Contact	silver-plated brass	

# High Current Feedthrough

## DN 40 ISO KF

### Properties

- ◆ Selection of three electrodes
- ◆ Slide into mounted feedthrough
- ◆ Current connection with water cooling



### Selection Data

Vacuum connection		DN 40 ISO-KF
Number of feedthroughs		1
Voltage	V	100
Current	A	250/1500 <sup>1)</sup>

<sup>1)</sup> With water cooling

### Ordering Information

<b>Feedthrough with O-ring KF40</b>	<b>214-141</b>
<b>Current connection with water cooling <sup>2)</sup></b>	<b>214-145</b>
<b>Straight electrode</b>	<b>214-142</b>
<b>Angle electrode</b>	<b>214-143</b>

<sup>2)</sup> Not insulated

### Specifications

Tightness	mbar l/s	$1 \times 10^{-9}$
Pressure (absolute)		$1 \times 10^{-8}$ mbar ... 2.5 bar (max. 10 bar with external centering ring)
Bakeout temperature	°C	110
Housing		aluminum 6063/3.2315
Insulator		thermoplast and thermoset
Seal		FPM

## DN 40 ISO KF - continued

### Dimensions

214-141

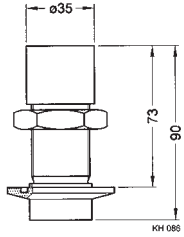

Feedthrough

214-145

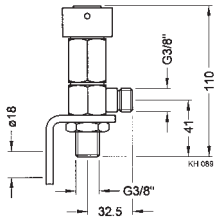

Current connection  
with water cooling  
copper/brass

214-142

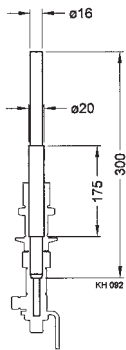

Electrodes copper/brass

214-143

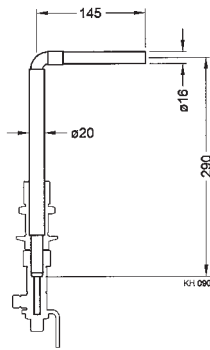

Electrodes copper/brass

# Coaxial Feedthroughs ISO-KF / CF-F

## BNC / MHV DN 16 – 40

### Properties

- Based on MIL-C-39012A
- Voltage up to 5 kV DC
- With atmospheric connector



### Selection Data

Vacuum connection	DN 16 ISO-KF	DN 16 ISO-KF	DN 16 CF-F	DN 16 CF-F	DN 40 CF-F
Number of feedthroughs	1	1	1	1	3

### Ordering Information

Type	BNC	MHV	BNC	MHV	MHV
Part No.	214-151	214-152	214-155	214-156	214-157

### Specifications

Voltage						
AC, 50 Hz	kV	0.35	3.5	0.35	3.5	3.5
DC	kV	0.5	5	0.5	5	5
Current	A	3	3	3	3	3
Frequency	MHz	150		150		
Impedance	$\Omega$	50-60		50-60		
Insulation resistance at 20°C	$\Omega$	$10^{10}$	$10^{10}$	$10^{10}$	$10^{10}$	$10^{10}$
Tightness	mbar l/s	$1 \times 10^{-9}$	$1 \times 10^{-9}$	$1 \times 10^{-10}$	$1 \times 10^{-10}$	$1 \times 10^{-10}$
Pressure (absolute) <sup>1)</sup>		$1 \times 10^{-8}$ mbar to 2.5 bar	$1 \times 10^{-8}$ mbar to 2.5 bar	$1 \times 10^{-10}$ mbar to 10 bar	$1 \times 10^{-10}$ mbar to 10 bar	$1 \times 10^{-10}$ mbar to 10 bar
Housing, flange, conductor		stainless steel	stainless steel	stainless steel	stainless steel	stainless steel
Feedthrough, seal		Al <sub>2</sub> O <sub>3</sub>	Al <sub>2</sub> O <sub>3</sub>	Al <sub>2</sub> O <sub>3</sub>	Al <sub>2</sub> O <sub>3</sub>	Al <sub>2</sub> O <sub>3</sub>
Bakeout temperature						
With connector	°C	50	50	50	50	50
Without connector	°C	200	200	400	400	400
Standart connection						
Atmospheric connector		UG 88/U	UG 932/U	UG 88/U	UG 932/U	UG 932/U
Cable		RG 58/U	RG 59/U	RB 58/U	RG 59/U	RG 59/U
Weight	kg	0.1	0.1	0.14	0.14	0.5

<sup>1)</sup> Pressure at 400°C : 2 bar

# BNC / MHV DN 16 – 40 - continued

## Dimensions

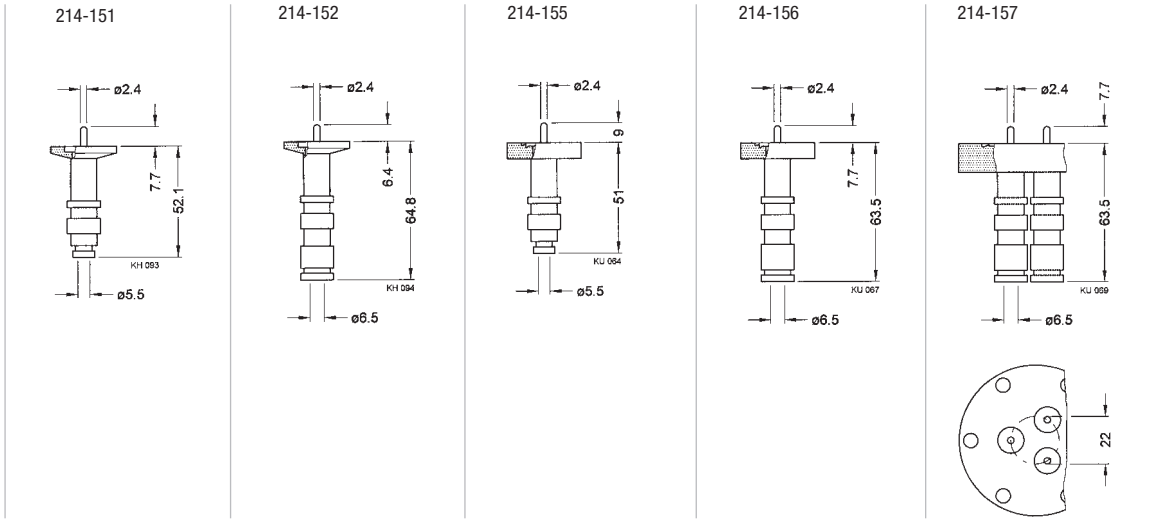

# Vacuum Feedthroughs

## METAL-CERAMIC CONNECTIONS

### Properties

- High grade materials allow repeated bakings up to 400°C



### Selection Data

Voltage <sup>1)</sup>	3 kV	2 kV	5 kV	10 kV
-----------------------	------	------	------	-------

### Ordering Information

Part No.	214-161	214-162	214-163	214-164
----------	---------	---------	---------	---------

### Specifications

Insulator		Al <sub>2</sub> O <sub>3</sub>	Al <sub>2</sub> O <sub>3</sub>	Al <sub>2</sub> O <sub>3</sub>	Al <sub>2</sub> O <sub>3</sub>
Connection					
a		Fe-Ni	Fe-Ni	Fe-Ni	Fe-Ni
b		Fe-Ni	stainless steel 304/1.4301	stainless steel 304/1.4301	stainless steel 304/1.4301
Bakeout temperature	°C	400	400	400	400
Tightness	mbar l/s	5 x 10 <sup>-11</sup>	5 x 10 <sup>-11</sup>	5 x 10 <sup>-11</sup>	5 x 10 <sup>-11</sup>
Weight	g	5	12	25	90

<sup>1)</sup> Based on VDE 0110 for air and surface-leakage in atmosphere on both sides.  
Higher values up to factor two are admissible in pressures <10<sup>-4</sup> mbar.

# METAL-CERAMIC CONNECTIONS - continued

## Dimensions

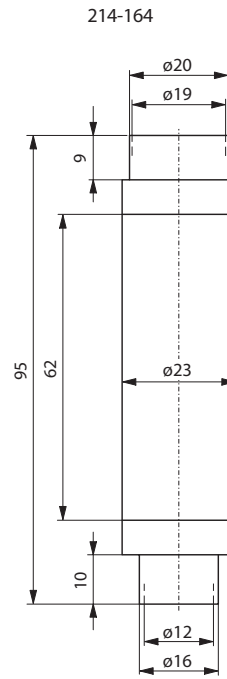
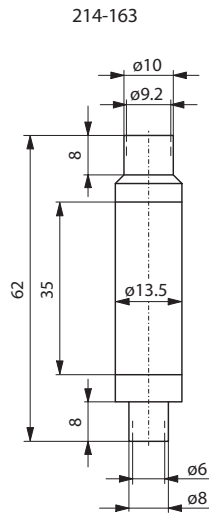
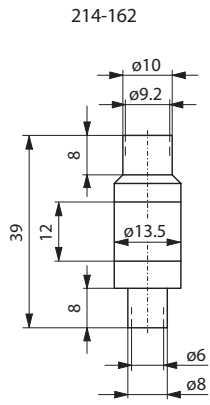
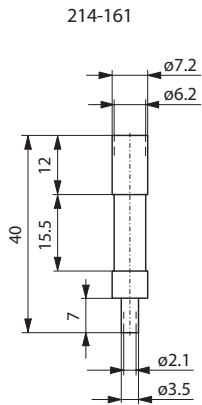



# Liquid Feedthroughs ISO-KF / CF-F

## DN 40

### Properties

- For H<sub>2</sub>O and LN<sub>2</sub>
- Thermally insulated
- Specially suited for very hot and very cold applications

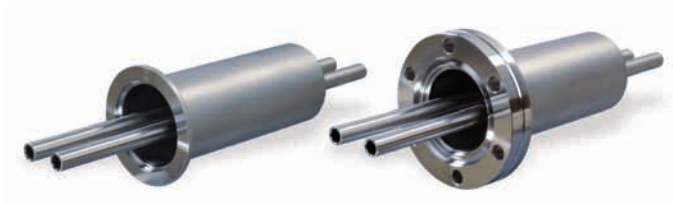

### Selection Data

Vacuum connection		DN 40 ISO-KF	DN 40 CF-F
Feedthrough/seal		welded	welded
Tube dimensions	mm	Ø 8 x 1	Ø 8 x 1
Number of tubes		2	2

### Ordering Information

Part No.	214-101	214-102
----------	---------	---------

### Specifications

Tightness	mbar l/s	1 x 10 <sup>-9</sup>	1 x 10 <sup>-10</sup>
Pressure		10 <sup>-8</sup> mbar ... 10 bar	10 <sup>-9</sup> mbar ... 10 bar
Temperature range	°C	-200 ... +150	-200 ... +400
Material		stainless steel 304/1.4301	stainless steel 304/1.4301
Weight	kg	0.3	0.4

## DN 40 - continued

### Dimensions

214-101

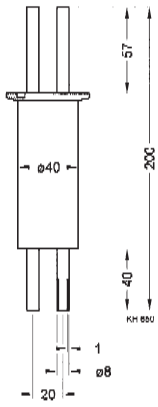

214-102

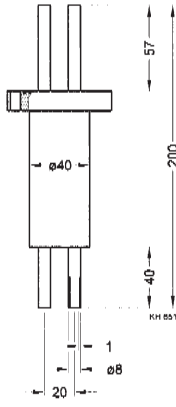

# Viewports

## DN 25 – DN 50 ISO-KF

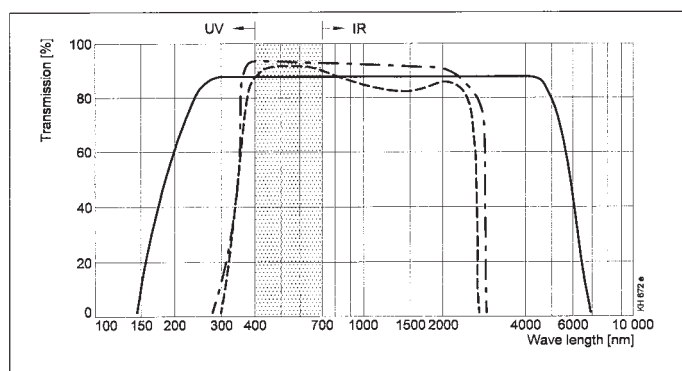

Average transmittance curve

- Sapphire
- . - Kodial
- - - Borosilicate

### Properties

- Wide viewing angle

### Selection Data

Vacuum connection	DN 25 ISO-KF	DN 40 ISO-KF	DN 50 ISO-KF
Window		borosilicate glass	
Seal		FPM	
Flange		aluminum 6082/3.2315	
Bakeout temperature	°C	150	

### Ordering Information

Part No.	214-003	214-004	214-005
----------	---------	---------	---------

### Specifications

Tightness	mbar l/s	1 x 10 <sup>-9</sup>	
Pressure (absolute)		1 x 10 <sup>-8</sup> mbar ... 4 bar	
Max. at 150°C	bar	3	
Window thickness	mm	3.8	
Weight	g	20	30
			40

## DN 25 – DN 50 ISO-KF – continued

### Dimensions

214-003

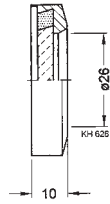

214-004

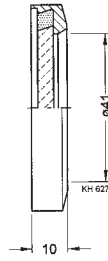

214-005

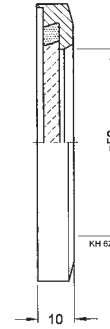

Mounting

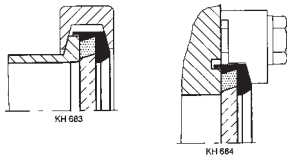

Claws, screws and clamping ring not included

# Viewports

## DN 63 – DN 160 ISO-K

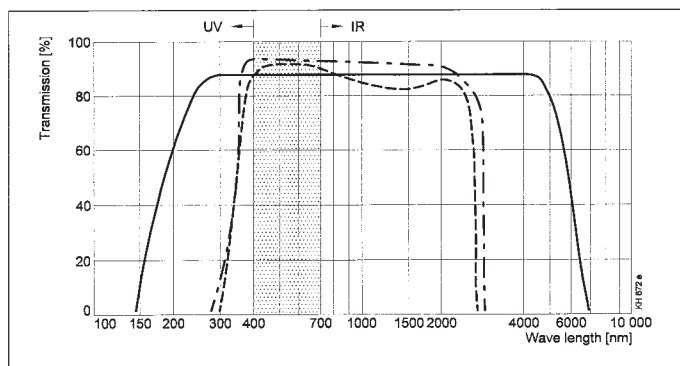

Average transmittance curve

- Sapphire
- - - Kodial
- . - Borosilicate



### Properties

- Wide viewing angle

### Selection Data

Vacuum connection	DN 63 ISO-K	DN 100 ISO-K	DN 160 ISO-K
Window		borosilicate glass	
Seal		FPM	
Flange		aluminum 6082/3.2315	
Bakeout temperature	°C	150	

### Ordering Information

Part No.	214-006	214-007	214-008
----------	---------	---------	---------

### Specifications

Tightness	mbar l/s	1 x 10 <sup>-9</sup>		
Pressure (absolute)		1 x 10 <sup>-8</sup> mbar ... 2 bar		
Max. at 150°C	bar	1		
Window thickness	mm	6	8	10
Weight	kg	0.2	0.3	0.4

<sup>1)</sup> Claws not included

# DN 63 – DN 160 ISO-K - continued

## Dimensions

214-006

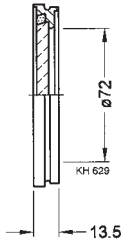

214-007

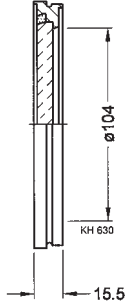

214-008

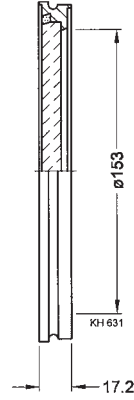

### Mounting

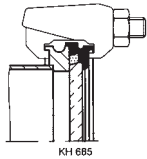

# Viewports

## DN 16 – DN 160 CF

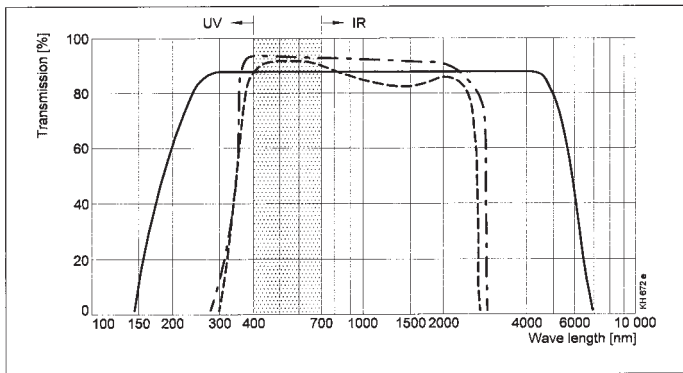

Average transmittance curve

- Sapphire
- - - Kodial
- . - Borosilicate



### Properties

- Protection window
- With Fe-Ni alloy as transition material

### Selection Data

Vacuum connection	DN 16 CF-F	DN 40 CF-F	DN 40 CF-F	DN 63 CF-F	DN 100 CF-F	DN 160 CF-F
Window	kodial glass	kodial glass	sapphire glass	kodial glass	kodial glass	kodial glass
Seal	iron/nickel					
Flange	stainless steel 304/1.4301					
Bakeout temperature	°C 400					

### Ordering Information

<b>Viewport</b>	<b>214-021</b>	<b>214-022</b>	<b>214-032</b>	<b>214-023</b>	<b>214-024</b>	<b>214-025</b>
<b>Bolt set</b>	<b>213-416</b>	<b>standard</b>	<b>standard</b>	<b>standard</b>	<b>standard</b>	<b>standard</b>

### Specifications

Tightness	mbar l/s	5 x 10 <sup>-11</sup>					
Pressure (absolute)		1 x 10 <sup>-10</sup>					
Min.	mbar	1					
Max.	bar	2					
Max. at 400°C	bar	1					
Window thickness	mm	1.5	3	3	3.5	6	8
Weight	kg	0.04	0.24	0.35	0.85	1.4	2.8

# DN 16 – DN 160 CF – continued

## Dimensions

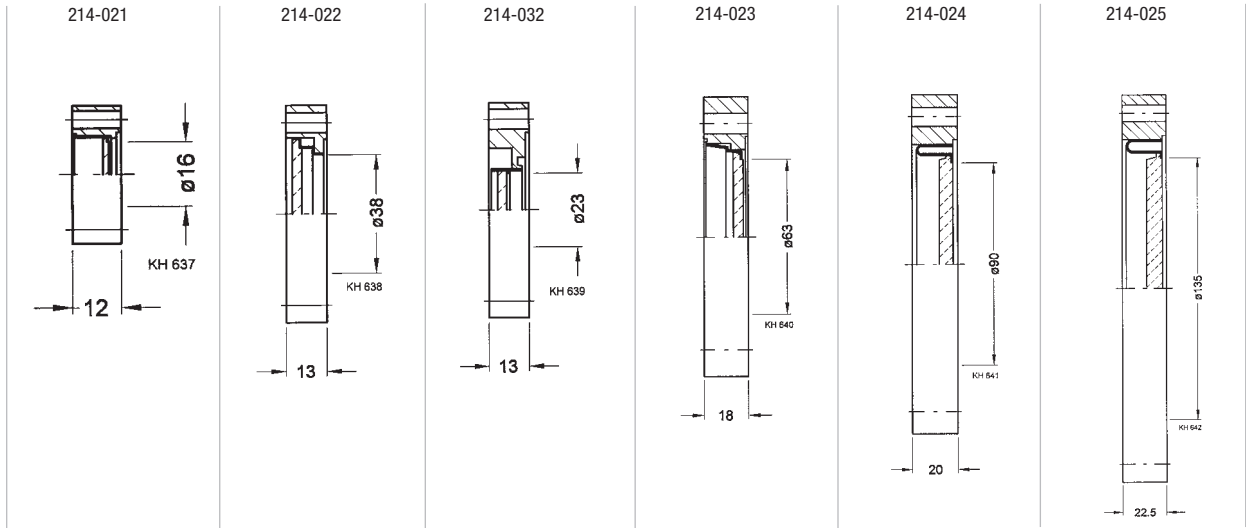

### Mounting

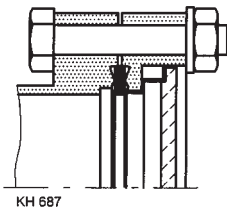



# Viewports

## DN 63 – DN 160 ISO-F

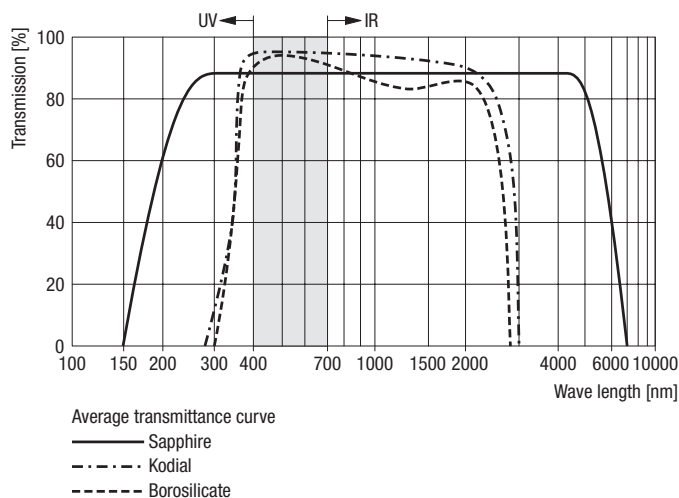

### Properties

- Wide viewing angle

### Selection Data

Vacuum connection	DN 63 ISO-F	DN 100 ISO-F	DN 160 ISO-F
Window		borosilicate glass	
Seal		FPM	
Flange		black anodized aluminum 6063/3.2315	
Centering ring		aluminum 6063/3.2315	
Snap ring		stainless steel 304/1.4301	
Bakeout temperature	°C	150	

### Ordering Information

Viewport <sup>1)</sup>	Part No.	214-016	214-017	214-018
Protective glass, 5 pcs.	Part No.	214-046	214-047	214-048

<sup>1)</sup> Claws, bolts, nuts and washer included

### Specifications

Tightness	mbar l/s	1 x 10 <sup>-9</sup>		
Pressure (absolute)		1 x 10 <sup>-8</sup> mbar ... 2 bar		
Max. at 150°C	bar	1		
Window thickness	mm	7.5	11	15
Protective glass thickness	mm	2.5	2.5	2.5
Weight	kg	0.8	1.4	3

## DN 63 – DN 160 ISO-F - continued

### Dimensions

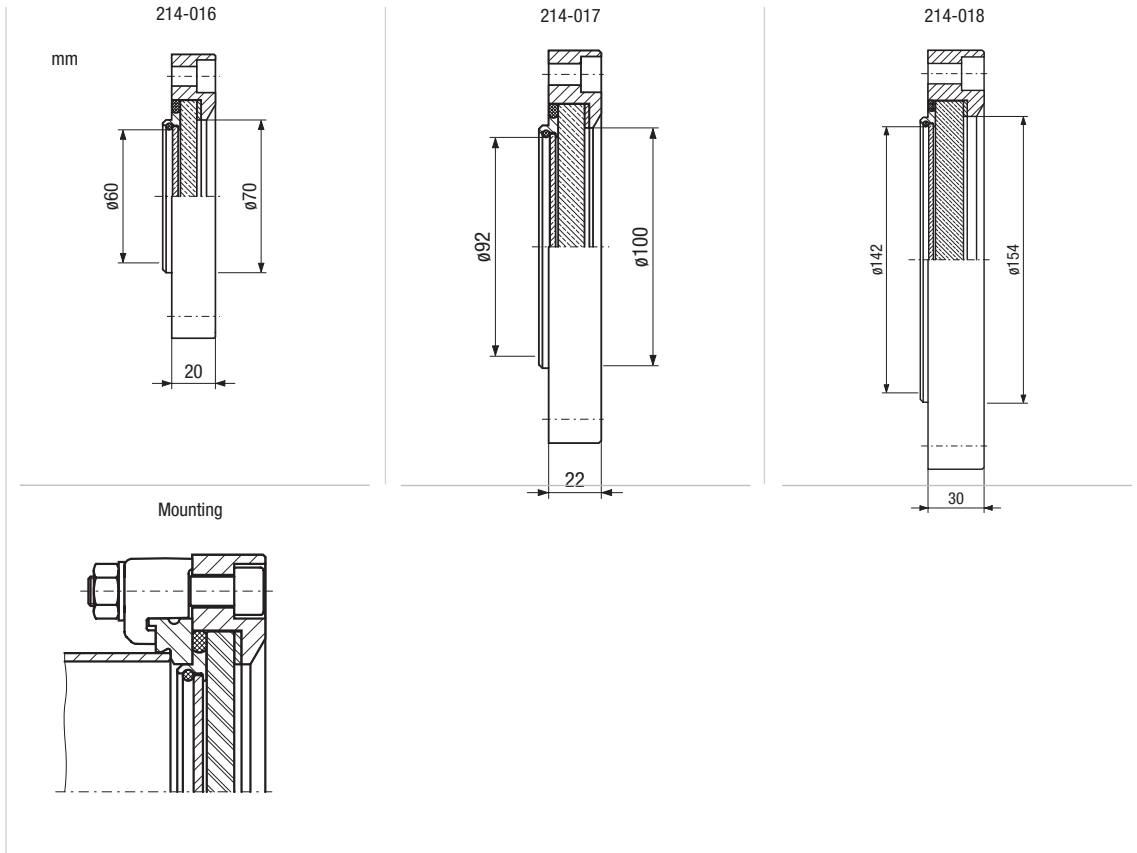

# Vacuum Feedthroughs

## VACUUM BALL BEARINGS

### Properties

- Specially suited for clean vacuum applications and extreme residual gas requirements
- With shields (non-rubbing seals)
- With dry lubrication
- Bearing clearance



### Selection Data

Service life <sup>1)</sup> (revolutions)		> 20 Mio.
Pressure (absolute)	mbar	$1 \times 10^{-12} \dots 1 \times 10^{-2}$
Operating temperature <sup>2)</sup>	°C	-200 ... +300
Material		stainless steel 440C/1.3543, 304/1.4301

### Ordering Information

Type	624	605	626	608	6000	6001
Part No.	214-211	214-212	214-213	214-214	214-215	214-216

### Specifications

Rotational speed at								
		624	605	626	608	6000	6001	
20°C	rpm	5000	4000	3000	2500	2000	1500	
300°C	rpm	1500	1500	1000	800	500	300	
Load capacity <sup>3)</sup>	Static CO	N	400	400	800	1000	1500	2000
	Dynamic C	N	50	50	100	150	200	250
	Axial load		<<C	<<C	<<C	<<C	<<C	<<C
Fit according to ISO		G6 / f6	G6 / f6	G6 / f6	G6 / f6	G6 / f6	G6 / f6	
Weight	g	3	4	8	13	20	25	

<sup>1)</sup> At half load and > 1000/min

<sup>2)</sup> At -200°C reduction of tenacity

<sup>3)</sup> At 20°C; half value at 300°C

# VACUUM BALL BEARINGS - continued

## Dimensions

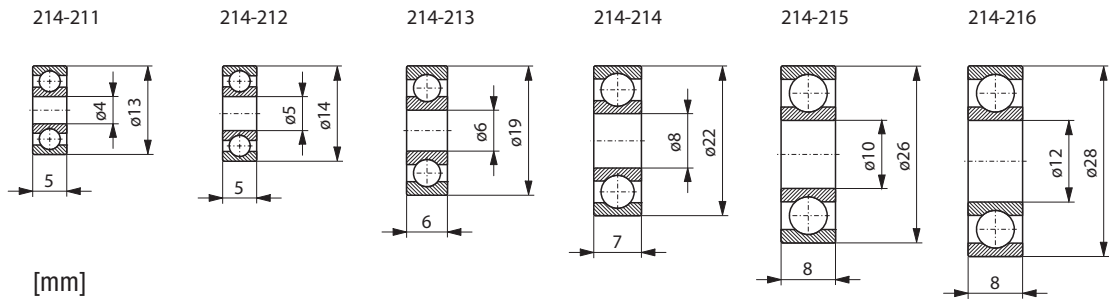

# Vacuum Feedthroughs

## LUBRICANTS AND SEALING MATERIALS



### High Temperature Lubricant

- Prevents seizing of stainless steel screw connections at atmosphere even at high temperatures
- Remains fully effective for at least 10 bakeout cycles

#### Selection Data

Temperature resistance	1000°C
In packages of	28 g

#### Ordering Information

Type	C 100
Part No.	214-231

### Sealing Material

- For sealing small leaks

#### Selection Data

Temperature resistance	°C	-40 - 200	350
Version		Paste	Spray
In packages of	g	200	170

#### Ordering Information

Type	Rhosil 340	Sprayseal
Part No.	214-233	214-234

## LUBRICANTS AND SEALING MATERIALS - continued

### Vacuum Grease/Oil

- For sliding elastomer seals
- Low vapor pressure
- Good adhesiveness

#### Selection Data

Temperature resistance	°C	10 - 30	-40 - 200	-20 - 200	-60 - 300	-60 - 300
Vapor pressure at 20°C	mbar	<10 <sup>-8</sup>	<5 x 10 <sup>-7</sup>	< 10 <sup>-12</sup>	< 10 <sup>-12</sup>	< 10 <sup>-12</sup>
100°C	mbar		<7 x10 <sup>-6</sup>	< 10 <sup>-7</sup>	< 10 <sup>-7</sup>	< 10 <sup>-7</sup>
In packages of		25 g	50 g	10 g	30 g	10 ml
Material		mineral grease	silicon grease	fluorinated grease	fluorinated grease with MoS <sub>2</sub>	fluorinated oil

#### Ordering Information

Type	Apezon M	Dow Corning	FU 090	FM 090	OL 090
Part No.	214-236	214-237	214-238	214-239	214-240

#### Characteristics

	Apezon M	Dow Corning	FU 090	FM 090	OL 090
Lubricity	very good	good	good	good/very good	good
Resistance to Oxidation		very good	very good	very good	very good
Chemicals		good	very good	very good	very good
Thermal decomposition		very good	good	good	good



---

# **Vacuum Valves**

---

## VACUUM VALVES

### Angle and Inline Valves ( VAH, VAP, VAM, VIM)

ISO-KF DN 5 manually, pneumatically, solenoid . . . . .	C1
---	----

### Angle and Inline Valves ( VAH, VIH, VAP, VIP, VAM)

ISO-KF DN16 - 40 manually. . . . .	C4
ISO-KF DN16 - 40 manually (Diaphragm Valves). . . . .	C8
ISO-KF DN16 - 40 pneumatically . . . . .	C10
ISO-KF/CF-R DN16 - 40 pneumatically . . . . .	C14
ISO-KF DN16 - 40 solenoid . . . . .	C19
ISO-KF DN63 manually, pneumatically . . . . .	C22
ISO-KF DN100 manually, pneumatically . . . . .	C25
ISO-KF DN160 pneumatically . . . . .	C28

### Butterfly Valves (VBH, VBP)

ISO-KF DN63 - 160 manually . . . . .	C30
ISO-KF DN63 - 250 pneumatically . . . . .	C32

### Dosing Valves (VDH)

ISO-KF DN10 manually (coarse gas dosing) . . . . .	C38
ISO-KF DN16 manually (fine gas dosing / shut-off) . . . . .	C39

### Dosing Systems (VDM, VDE, VCE, VCC, VCA)

All-Metal Dosing Valves and System . . . . .	C41
Gas Dosing Systems . . . . .	C44
Solenoid Control Valves . . . . .	C49

### All-Metal Angle Valves (VAH)

CF-R DN16 - 63 manually . . . . .	C51
-----------------------------------	-----

### Venting Valves (VWH, VWM, VIN)

ISO-KF DN10 manually . . . . .	C53
ISO-KF DN10 solenoid . . . . .	C54
ISO-KF DN10 solenoid (power failure) . . . . .	C56



## VACUUM VALVES (continued)

### Vacuum Safety Valves (VSM)

ISO-KF DN16 - 100 ..... C58

### Pressure Relief Valve (VSA)

ISO-KF DN16 ..... C59

### Ball Valves

ISO-KF DN10 - 40 ..... C60

### Website

# Angle and Inline Valves ( VAH, VAP, VAM, VIM)

## DN 5

### Manually Actuated

- Angle valve
- Spindle drive

### Pneumatically Actuated

- Angle valves
- With and without pilot valve

### Solenoid Actuated

- Angle and inline valves



### Selection Data

Actuation		manual	pneumatic	el.-pneumatic	solenoid	solenoid	solenoid
Feedthrough		bellows	bellows	bellows	without	without	without
Vacuum connection	mm	Ø5 / M 14 x 1	Ø5 / M 14 x 1	Ø5 / M 14 x 1	Ø5 / M 14 x 1	Ø5 / M 14 x 1	Ø5 / M 14 x 1
Service life <sup>1)</sup>	cycles	–	5 Mio	5 Mio	2 Mio	2 Mio	2 Mio
Attributes		angle valve	angle valve w/o pilot valve	angle valve with pilot valve	angle valve	inline valve normally closed	inline valve normally open

<sup>1)</sup> Under clean operating conditions

### Ordering Information

Type	VAH005-X	VAP005-X	VAP005-X	VAM005-X	VIM005-X	VIM005-Z
Valve / Part No.	<b>250-070</b>	<b>250-040</b>	–	–	–	–
Normally closed	–	–	<b>250-050</b>	<b>250-000</b>	<b>250-010</b>	–
Normally open	–	–	<b>250-060</b>	–	–	<b>250-020</b>

### Spare Parts

Seal set	<b>215-373</b>	<b>215-372</b>	<b>215-372</b>	<b>215-371</b>	<b>215-371</b>	<b>215-371</b>
Spare parts set	<b>215-369</b>	<b>215-368</b>	<b>215-368</b>	<b>215-365</b>	<b>215-366</b>	<b>215-367</b>

### Connection Elements

Type	Flange DN 10 ISO-KF	For pipe OD 1/4"	For pipe OD 6mm
Part No.	<b>250-080</b>	<b>250-085</b>	<b>250-086</b>

## DN 5 – continued

## Specifications

Type		VAH005-X manual	VAP005-X pneumatic	VAP005-X el.-pneumatic	VAM005-X solenoid	VIM005-X solenoid	VIM005-Z solenoid
Tightness	mbar l/s	1 x 10 <sup>-9</sup>	1 x 10 <sup>-9</sup>	1 x 10 <sup>-9</sup>	1 x 10 <sup>-9</sup>	1 x 10 <sup>-9</sup>	1 x 10 <sup>-9</sup>
Conductance for air							
Molecular flow	l/s	0.4	0.4	0.4	0.3	0.2	0.2
Laminar flow	l/s	4	4	4	3	2	2
Pressure range (absolute)	mbar ... bar	10 <sup>-8</sup> ... 4	10 <sup>-8</sup> ... 4	10 <sup>-8</sup> ... 4	10 <sup>-8</sup> ... 10	10 <sup>-8</sup> ... 10	10 <sup>-8</sup> ... 10
Pressure difference Δp							
In closing direction	bar	4	3	3	5	5	4
In opening direction	bar	4	3	3	1.5	1.5	2
Opens against Δp <sup>1)</sup>	bar	4	3	3	1	1	4
Temperature							
Ambient	°C	5 <sup>2)</sup> ... 70	5 <sup>2)</sup> ... 80	5 <sup>2)</sup> ... 40	5 <sup>2)</sup> ... 40	5 <sup>2)</sup> ... 40	5 <sup>2)</sup> ... 40
Closing time	ms	–	35 / 35	35 / 35	7 / 30	7 / 30	30 / 10
Opening time	ms	–	–	–	–	–	–
Switching frequency	1/min	–	150	150	300	300	300
Degree of protection		–	IP 65	IP 65	IP 65	IP 65	IP 65
Supply voltage/	V DC	–	–	24	24	24	24
Power consumption	W	–	–	1	10	10	10
Materials							
Housing		304/1.4301	304/1.4301	304/1.4301	304/1.4301	304/1.4301	304/1.4301
Actuator		Al & plastic	anodized Al	anodized Al	–	–	–
Bellows		304/1.4301	304/1.4301	304/1.4301	–	–	–
Valve plate		304/1.4301	304/1.4301	304/1.4301	–	–	–
Guiding tube		–	–	–	303/1.4105	303/1.4105	303/1.4105
Armature		–	–	–	303/1.4105	303/1.4105	303/1.4105
Seals		FPM	FPM	FPM	FPM	FPM	FPM
Weight	kg	0.15	0.20	0.20	0.26	0.28	0.30

<sup>1)</sup> Compressed air: overpressure 4 bar

<sup>2)</sup> –15°C, if the ambience is free of condensable gases

**Dimensions**

VAH005-X



VAP005-X



VAP005-X



VAM005-X



VIM005-X

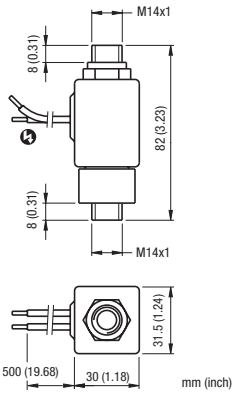

VIM005-Z

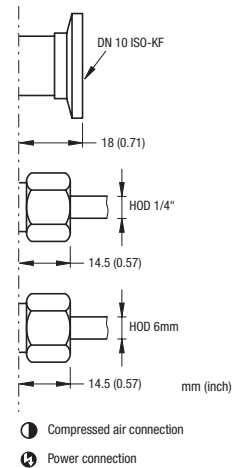
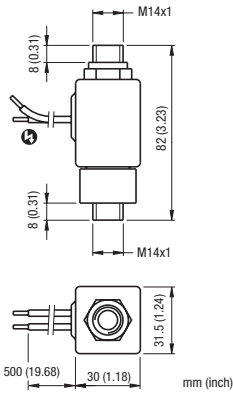

- Compressed air connection
- ⚡ Power connection

## Angle and Inline Valves ( VAH, VIH) Manually Actuated

VAH016 ... 040-A/X

VIH016 ... 040-A/X

The INFICON ISO-KF valve line, VAH / VIH016 ... 040-A/X performs as a gauge isolation, bypass, roughing or venting valve and is well suited for all general high vacuum and semiconductor processes. The improved industrial design results in a rugged, compact, easy to operate valve. The visual position indicator shows the open / close status of the valve for clear understanding of valve status. The extremely long service life and easy to maintain design results in a highly reliable valve with low cost of ownership. The new line is compatible with the current INFICON VAH / VIH016 ... 040-A/X valve line.



### Advantages

- Ergonomically designed knob for secure grip
- Fast open / close actuation with one 130° turn; or a soft continuously variable actuation for controlled venting / pumping of vacuum systems
- Low operating force required, even if the valve is opened against vacuum
- Drive locks into final open / close position
- Visual position indicator, standard
- 316L stainless steel bellows
- Easy maintenance, fast bellows and seal replacement
- High conductance for fast pump down or venting
- High differential pressure resistance
- FPM sealing standard, other sealing materials available upon request
- High purity aluminum or stainless steel housing

## VAH016 ... 040-A/X

## VIH016 ... 040-A/X - continued

### Selection Data

Vacuum connection	DN 16 ISO-KF		DN 25 ISO-KF		DN 40 ISO-KF	
Aluminum housing	AISI/DIN	-/EN AW-6082	-/EN AW-6082	304/1.4301	-/EN AW-6082	304/1.4301
Stainless steel housing	AISI/DIN	304/1.4301	304/1.4301		304/1.4301	

### Ordering Information

#### Angle Valve

Type	VAH016-A	VAH016-X	VAH025-A	VAH025-X	VAH040-A	VAH040-X
	253-200	253-245	253-300	253-345	253-400	253-445

#### Inline Valve

Type	VIH016-A	VIH016-X	VIH025-A	VIH025-X	VIH040-A	VIH040-X
	253-225	253-265	253-325	253-365	253-425	253-465

### Specifications

Cycle life	Cycles	10000	10000	10000			
Conductance for molecular flow							
Angle valve	l/s	5	14	45			
Inline Valve	l/s	2.5	7	20			
Tightness	mbar l/s	$1 \times 10^{-9}$	$1 \times 10^{-9}$	$1 \times 10^{-9}$			
Operating pressure min. / max.	mbar / bar	$1 \times 10^{-8} / 2$	$1 \times 10^{-8} / 2$	$1 \times 10^{-8} / 1.5$			
Pressure, max. (absolute)	bar	4	4	4			
Pressure difference							
In closing direction	bar	4	4	2			
In opening direction	bar	2	2	1.5			
Ambiance temperature	°C	0 ... +50	0 ... +50	0 ... +50			
Mounting orientation		any	any	any			
Seals		FPM	FPM	FPM			
Weight							
Angle valve	kg	0.31	0.34	0.42	0.49	0.85	0.96
Inline valve	kg		0.71		1.09		1.83

### Spare Parts

Vacuum connection	DN 16 ISO-KF	DN 25 ISO-KF	DN 40 ISO-KF
Seal kit	299-001	299-006	299-011
O-rings for one valve			
Bellows cpl.	299-002	299-007	299-012
Bellows & seal kit			

# VAH016 ... 040-A/X

## VIH016 ... 040-A/X - continued

### Dimensions Angle Valve

Aluminum housing

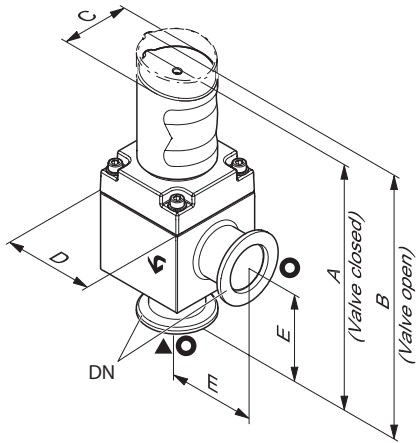

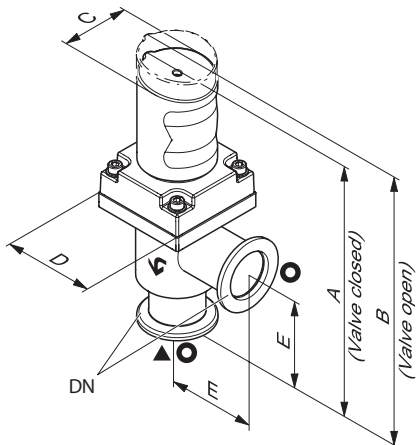

DN	A	B	C	D	E
DN 16 ISO-KF	141.3	149.5	39.6	45	40
DN 25 ISO-KF	145.3	155.7	39.6	54	50
DN 40 ISO-KF	186.2	201.4	50	69	65

Stainless steel housing



DN	A	B	C	D	E
DN 16 ISO-KF	143.9	152.1	39.6	45	40
DN 25 ISO-KF	148.7	159.1	39.6	54	50
DN 40 ISO-KF	189.2	204.4	50	69	65

-  Protective lid
-  Valve seat site
-  Flow direction

# VAH016 ... 040-A/X

## VIH016 ... 040-A/X - continued

### Dimensions Inline Valve

Stainless steel housing

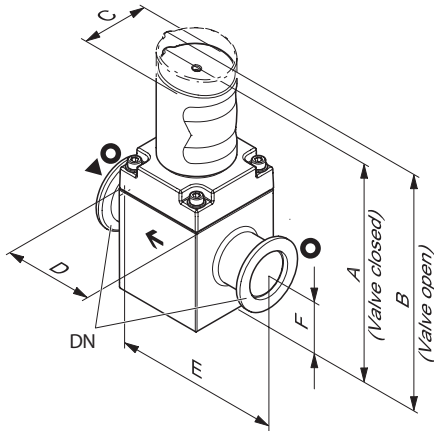

- Protective lid
- ▼ Valve seat site
- ← Flow direction

DN	A	B	C	D	E	F
DN 16 ISO-KF	125.4	133.6	39.6	45	80	20
DN 25 ISO-KF	132	142.4	39.6	54	100	31.8
DN 40 ISO-KF	166.5	181.7	50	69	130	40.8



# Diaphragm Valves Manually Actuated

## VIH016 ... 040-AD

The INFICON ISO-KF diaphragm valve line, VIH016 ... 040-AD performs as a gauge isolation, roughing or venting valve. The manual spindle drive allows easy gas dosing. The robust and rugged industrial design is well suited for gases and liquids and is resistant to contamination.



### Advantages

- Spindle drive for controlled venting and easy dosing
- Low operating force required
- Visual position indicator
- FPM diaphragm sealing; other sealing materials on request
- Aluminum inline housing EN AW-6082
- Easy maintenance, fast diaphragm seal replacement
- Small footprint and easy system integration

### Ordering Information Selection Data

Type	VIH016-AD	VIH025-AD	VIH040-AD
	253-481	253-482	253-483

### Spare Parts

Diaphragm (1 piece)	299-031	299-032	299-033
---------------------	---------	---------	---------

## VIH016 ... 040-AD - continued



### Specifications

		VIH016-AD	VIH025-AD	VIH040-AD
Vacuum connection		DN 16 ISO-KF	DN 25 ISO-KF	DN 40 ISO-KF
Cycle life	Cycles	>10000	>10000	>10000
Conductance for molecular flow	l/s	2	5	17
Tightness	mbar l/s	$1 \times 10^{-9}$	$1 \times 10^{-9}$	$1 \times 10^{-9}$
Operating pressure min. / max.	mbar / bar	$1 \times 10^{-7}$ / 5	$1 \times 10^{-7}$ / 5	$1 \times 10^{-7}$ / 5
Pressure, max. (absolute)	bar	5	5	5
Ambiance temperature	°C	0 ... +50	0 ... +50	0 ... +50
Mounting orientation		any	any	any
Diaphragm		FPM	FPM	FPM
Weight	kg	0.16	0.5	1.2

### Dimensions

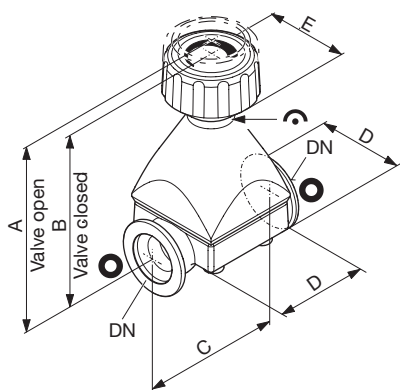
VIH016-AD, VIH025-AD



-  Protective lid
-  Visual position indicator

[mm]

DN	A	B	C	D	E	F
DN 16 ISO-KF	66	62	52	32.5	29.5	–
DN 25 ISO-KF	111	101	80	54	47	–
DN 40 ISO-KF	148.5	134.5	105	75	69.5	80

VIH040-AD

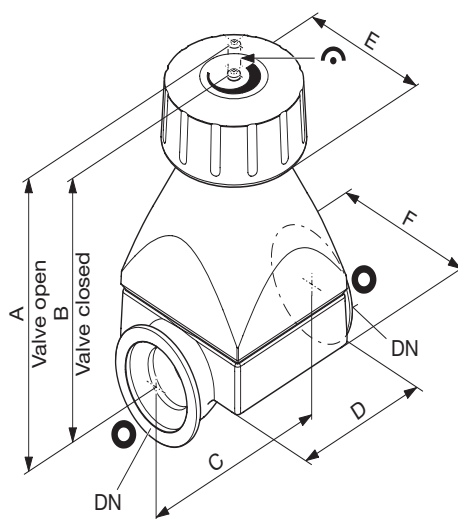

# Angle and Inline Valves ( VAP, VIP) Pneumatically Actuated

VAP016 ... 040-A/X

VIP016 ... 040-A/X

The INFICON ISO-KF valve line, VAP / VIP016 ... 040-A/X performs as gauge isolation, bypass, roughing or venting valve and is well suited for all general high vacuum and semiconductor processes. The improved industrial design results in a rugged, compact, highly reliable valve with a low cost of ownership. The All-in-One concept means the valve is fast and easy to install and the pilot valve and electrical position indicator are integrated for convenient “plug and play” use. The proven All-in-One design and extremely long service lifetime makes this valve easy to maintain. The new line is fully compatible with the current INFICON VAP / VIP016 ... 040-A/X valve line.



## Advantages

- All-in-One design for fast and easy installation; one connector for pilot valve and electrical position indicator for easiest “plug and play”
- Direct pneumatic actuation or via integrated pilot valve
- Normally open and normally closed versions available
- Electrical and visual position indicator, standard
- 10 million cycle 316L stainless steel bellows
- Easy maintenance, fast bellows and seal replacement
- Fast opening and closing time
- High conductance for fast pump down or venting
- High differential pressure resistance
- FPM sealing standard, other sealing materials available upon request
- High purity aluminum or stainless steel housing

## Ordering Information Selection Data

Vacuum connection	DN 16 ISO-KF		DN 25 ISO-KF		DN 40 ISO-KF	
Aluminum housing	AISI/DIN	-/EN AW-6060	-/EN AW-6060		-/EN AW-6060	
Stainless steel housing	AISI/DIN	304/1.4301	304/1.4301		304/1.4301	

## VAP016 ... 040-A/X

## VIP016 ... 040-A/X - continued

## Ordering Information

## Angle Valve

Type	VAP016-A	VAP016-X	VAP025-A	VAP025-X	VAP040-A	VAP040-X
Without pilot valve, with position indicator	253-210	253-250	253-310	253-350	253-410	253-450
With pilot valve, with position indicator						
24 V DC (n.c.)	253-211	253-251	253-311	253-351	253-411	253-451
24 V AC / 50 ... 60 Hz (n.c.)	253-212	253-252	253-312	253-352	253-412	253-452
100 ... 115 V AC / 50 ... 60 Hz (n.c.)	253-213	253-253	253-313	253-353	253-413	253-453
200 ... 230 V AC / 50 ... 60 Hz (n.c.)	253-214	253-254	253-314	253-354	253-414	253-454
24 V DC <b>normally open</b>	253-215	253-255	253-315	253-355	253-415	253-455

## Inline Valve

Type	VIP016-A	VIP016-X	VIP025-A	VIP025-X	VIP040-A	VIP040-X
Without pilot valve, with position indicator	253-230	253-270	253-330	253-370	253-430	253-470
With pilot valve, with position indicator						
24 V DC (n.c.)	253-231	253-271	253-331	253-371	253-431	253-471
24 V AC / 50 ... 60 Hz (n.c.)	253-232	253-272	253-332	253-372	253-432	253-472
100 ... 115 V AC / 50 ... 60 Hz (n.c.)	253-233	253-273	253-333	253-373	253-433	253-473
200 ... 230 V AC / 50 ... 60 Hz (n.c.)	253-234	253-274	253-334	253-374	253-434	253-474
24 V DC <b>normally open</b>	253-235	253-275	253-335	253-375	253-435	253-475

## Specifications

Cycle life	Mio cycles	10	10	10
Conductance for molecular flow				
Angle valve	l/s	5	14	45
Inline Valve	l/s	2.5	7	20
Tightness	mbar l/s	1 x 10 <sup>-9</sup>	1 x 10 <sup>-9</sup>	1 x 10 <sup>-9</sup>
Operating pressure min. / max.	mbar / bar	1 x 10 <sup>-8</sup> / 2	1 x 10 <sup>-8</sup> / 2	1 x 10 <sup>-8</sup> / 2
Pressure, max. (absolute)	bar	5	5	5
Pressure difference				
In closing direction	bar	5	5	5
In opening direction	bar	2	2	2
Ambiance temperature	°C	0 ... +50	0 ... +50	0 ... +50
Switching frequency	1/min	100	100	75
Opening time	ms	100	120	260
Closing time	ms	100	160	540
Electrical position indicator				
Rating	V AC/VA/A	250 / 25 / 0.1	250 / 25 / 0.1	250 / 25 / 0.1
	V DC/W/A	50 / 12.5 / 0.25	50 / 12.5 / 0.25	50 / 12.5 / 0.25
Compressed air, overpressure	bar	4 ... 8	4 ... 8	4 ... 8
Piston displacement	cm <sup>3</sup>	4	11	35
Mounting orientation		any	any	any
Seals		FPM	FPM	FPM
Weight				
Angle valve	kg	0.49	0.52	0.68
Inline valve	kg	0.56	0.89	0.78
				0.75
				1.21
				1.41
				1.33
				2.2

## VAP016 ... 040-A/X

## VIP016 ... 040-A/X - continued

### Spare Parts

Vacuum connection	DN 16 ISO-KF	DN 25 ISO-KF	DN 40 ISO-KF
Seal kit O-rings for one valve	299-001	299-006	299-011
Bellows cpl. Bellows & seal kit	299-002	299-007	299-012
Cover cpl. Receptacle, visual & electrical position indicator already assembled	299-003	299-008	299-013

### Accessories

Vacuum connection	DN 16 ISO-KF	DN 25 ISO-KF	DN 40 ISO-KF
Cable connector right angled	215-165	215-165	215-165

### Dimensions Angle Valve

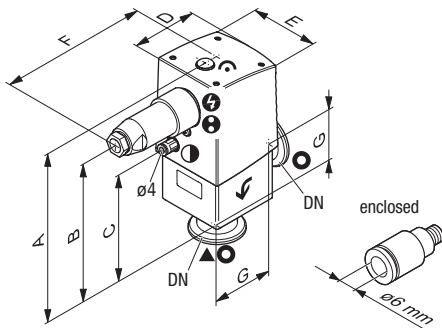

Aluminum housing

[mm]

DN	A	B	C	D	E	F	G
DN 16 ISO-KF	142	112.9	75.1	55	51.4	93.2	40
DN 25 ISO-KF	146.9	117.8	79	64.3	60.1	97.8	50
DN 40 ISO-KF	188.8	159.7	114.9	81.3	75.7	105.3	65

- ① Compressed air connection
- ⊙ Protective lid
- ⚡ Electrical connection
- ↷ Flow direction
- ⊕ Position indicator connection
- ▼ Valve seat site
- 👁 Visual position indicator

## VAP016 ... 040-A/X

## VIP016 ... 040-A/X - continued

### Dimensions Angle Valve

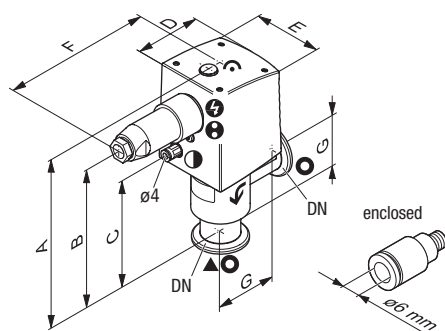

Stainless steel housing [mm]

DN	A	B	C	D	E	F	G
DN 16 ISO-KF	144.5	115.4	77.6	55	51.4	93.2	40
DN 25 ISO-KF	150.3	121.2	82.5	64.3	60.1	97.8	50
DN 40 ISO-KF	191.8	162.7	117.9	81.3	75.7	105.3	65

- ⊕ Compressed air connection
- ⊙ Protective lid
- ⚡ Electrical connection
- ↷ Flow direction
- ⊕ Position indicator connection
- ▼ Valve seat site
- ⤷ Visual position indicator

### Dimensions Inline Valve

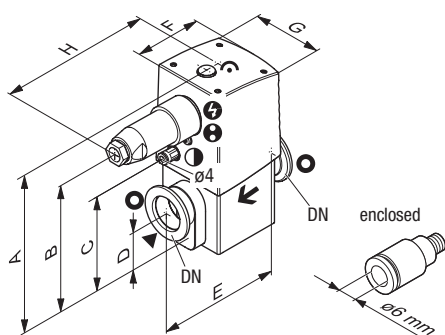

Aluminum housing [mm]

DN	A	B	C	D	E	F	G	H
DN 16 ISO-KF	133.1	104	66.2	18.7	80	55	51.4	93.2
DN 25 ISO-KF	137.6	108.5	69.7	25	100	64.3	60	97.8
DN 40 ISO-KF	177.1	148	103.2	30	130	81.2	75.7	105.3

Stainless steel housing [mm]

DN	A	B	C	D	E	F	G	H
DN 16 ISO-KF	126.1	97	59.2	20	80	55	51.4	93.2
DN 25 ISO-KF	133.6	104.5	65.7	31.8	100	64.3	60.1	97.8
DN 40 ISO-KF	169.1	140	95.2	40.8	130	81.3	75.7	105.3

- ⊕ Compressed air connection
- ⊙ Protective lid
- ⚡ Electrical connection
- ← Flow direction
- ⊕ Position indicator connection
- ▼ Valve seat site
- ⤷ Visual position indicator

# Angle and Inline Valves ( VAP, VIP) Pneumatically Actuated

VAP016 ... 040-A/X

VIP016 ... 040-A/X

The new INFICON ISO-KF and CF-R valve line, VAP / VIP016 ... 040-A/X performs as a gauge isolation, bypass, roughing or venting valve and is perfectly suited for all general high vacuum and semiconductor processes. The improved industrial design is very robust, compact and highly reliable with a low cost of ownership. This pneumatic actuated valve is designed for system manufacturers who need a compact and space saving valve unit. This valve comes with an outstanding long service life time and is very easy to maintain. It is equipped with the same approved high quality components like INFICON is using for its very successful All-in-One concept valve line.



## Advantages

- Robust and very compact design
- Visual position indicator, standard
- 10 million cycle 316L stainless steel bellows
- Easy maintenance due to fast bellows and seal replacement
- Fast opening and closing time
- High conductance for fast pump down or venting
- High differential pressure resistance
- FPM sealing standard. Other sealing materials available upon request
- High purity aluminum or stainless steel housing
- CF-R flanges for stainless steel housings available

## Order Information Selection Data

Vacuum connection	DN 16		DN 25		DN 40	
Aluminum housing	AISI/DIN	-/EN AW-6060	-/EN AW-6060		-/EN AW-6060	
Stainless steel housing	AISI/DIN	304/1.4301	304/1.4301		304/1.4301	

## VAP016 ... 040-A/X

## VIP016 ... 040-A/X - continued

### Ordering Information

#### Angle Valve ISO-KF

Type		VAP016-A	VAP016-X	VAP025-A	VAP025-X	VAP040-A	VAP040-X
Compressed air connection	∅ 4 mm	253-220	253-260	253-320	253-360	253-420	253-460
Compressed air connection	∅ 1/4"	253-222	253-262	253-322	253-362	253-422	253-462

#### Angle Valve CF-R

Type		VAP016-A	VAP016-X	VAP025-A	VAP025-X	VAP040-A	VAP040-X
Compressed air connection	∅ 1/4"	—	253-261	—	—	—	253-461

#### Inline Valve ISO-KF

Type		VIP016-A	VIP016-X	VIP025-A	VIP025-X	VIP040-A	VIP040-X
Compressed air connection		253-240	253-280	253-340	253-380	253-440	253-480

### Specifications

Cycle life	Mio cycles	10		10		10	
Conductance for molecular flow							
Angle valve	l/s	5		14		45	
Inline Valve	l/s	2.5		7		20	
Tightness	mbar l/s	1 x 10 <sup>-9</sup>		1 x 10 <sup>-9</sup>		1 x 10 <sup>-9</sup>	
Operating pressure min. / max.	mbar / bar	1 x 10 <sup>-8</sup> / 2		1 x 10 <sup>-8</sup> / 2		1 x 10 <sup>-8</sup> / 2	
Pressure, max. (absolute)	bar	5		5		5	
Pressure difference							
In closing direction	bar	5		5		5	
In opening direction	bar	2		2		2	
Ambiance temperature	°C	0 ... +50		0 ... +50		0 ... +50	
Bakeout temperature							
Housing	°C	120	150	120	150	120	150
Actuator	°C	120	120	120	120	120	120
Switching frequency	1/min	100		100		75	
Opening time	ms	100		120		260	
Closing time	ms	100		160		540	
Compressed air, overpressure	bar	4 ... 8		4 ... 8		4 ... 8	
Piston displacement	cm <sup>3</sup>	4		11		35	
Mounting orientation		any		any		any	
Seals		FPM		FPM		FPM	
Weight							
Angle valve ISO-KF	kg	0.38	0.42	0.57	0.66	1.17	1.28
Angle valve CF-R	kg	—	0.43	—	—	—	1.46
Inline valve ISO-KF	kg	0.45	0.83	0.67	1.27	1.38	2.48



## VAP016 ... 040-A/X

## VIP016 ... 040-A/X - continued

### Spare Parts

Vacuum connection	DN 16 ISO-KF	DN 25 ISO-KF	DN 40 ISO-KF
Seal kit O-rings for one valve	299-001	299-006	299-011
Bellows cpl. Bellows & seal kit	299-002	299-007	299-012

### Dimensions Angle Valve ISO-KF

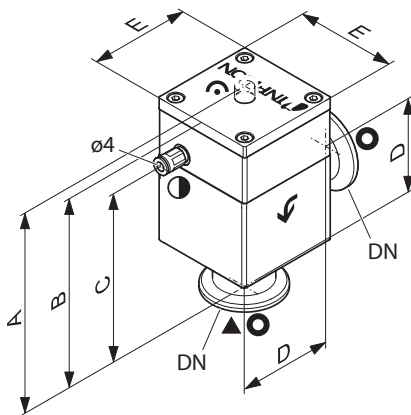

Aluminum housing [mm]

DN	A	B	C	D	E
DN 16 ISO-KF	100.5	95.7	75.6	40	45
DN 25 ISO-KF	108.5	102.6	80.6	50	54
DN 40 ISO-KF	150.5	144.7	116.6	65	69

-  Compressed air connection
-  Protective lid
-  Flow direction
-  Valve seat site
-  Visual position indicator

## VAP016 ... 040-A/X

## VIP016 ... 040-A/X - continued

### Dimensions Angle Valve ISO-KF

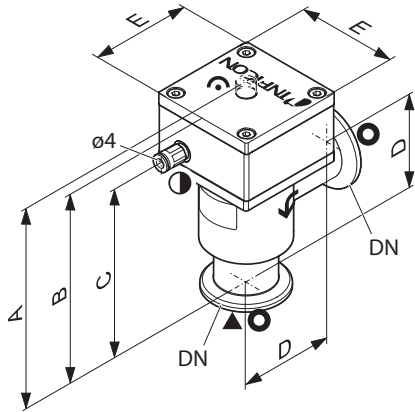

-  Compressed air connection
-  Protective lid
-  Flow direction
-  Valve seat site
-  Visual position indicator

Stainless steel housing					[mm]
DN	A	B	C	D	E
DN 16 ISO-KF	103	98.2	78.1	40	45
DN 25 ISO-KF	112	106	84	50	54
DN 40 ISO-KF	153.5	147.7	119.6	65	69

### Dimensions Angle Valve CF-R

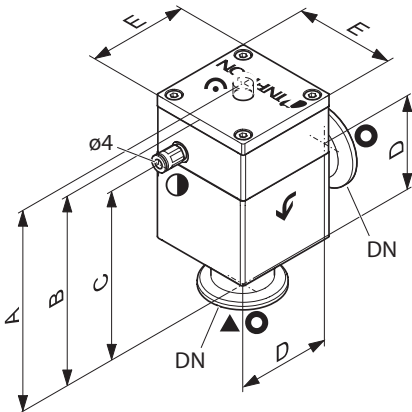

-  Compressed air connection
-  Protective lid
-  Flow direction
-  Valve seat site
-  Visual position indicator

Stainless steel housing					[mm]
DN	A	B	C	D	E
DN 16 CF-R	101	96.3	76.2	38	45
DN 40 CF-R	151.6	145.8	117.7	63	69

# VAP016 ... 040-A/X

## VIP016 ... 040-A/X - continued

### Dimensions Inline Valve ISO-KF

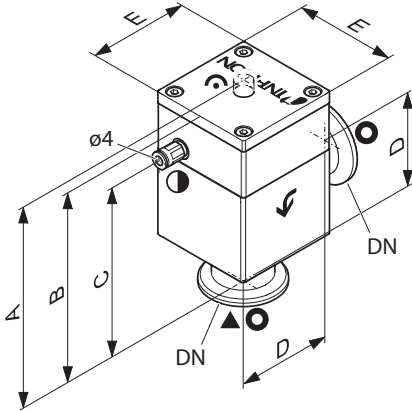

Aluminum housing [mm]

DN	A	B	C	D	E	F
DN 16 ISO-KF	91.8	86.8	66.7	18.7	80	45
DN 25 ISO-KF	98.5	93.3	71.3	25	100	54
DN 40 ISO-KF	138	133	104.9	30	130	69

Stainless steel housing [mm]

DN	A	B	C	D	E	F
DN 16 ISO-KF	84.5	79.8	59.7	20	80	45
DN 25 ISO-KF	95.5	89.3	67.3	31.8	100	54
DN 40 ISO-KF	131	125	96.9	40.8	130	69

- Compressed air connection
- Protective lid
- ↻ Flow direction
- ▼ Valve seat site
- ◐ Visual position indicator

# Solenoid Actuated Angle Valves

## VAM016 ... 040-A/X

### Advantages

- Bellows feedthrough, stainless steel 316L
- Compact design
- Electrical and visual (LED) position indication
- Selectable operating mode
  - Remote control via PLC or PC
  - Local operation
- Wide voltage range
- Easy maintenance, fast bellows and seal replacement
- Fast opening and closing time
- FPM sealing standard, other sealing materials available upon request
- Aluminum or stainless steel housing
- High conductance for fast pump down or venting



### Selection Data

Vacuum connection	DN 16 ISO-KF		DN 25 ISO-KF		DN 40 ISO-KF	
Aluminum housing	AISI/DIN	-/EN AW-6060	-/EN AW-6060	304/1.4301	-/EN AW-6060	304/1.4301
Stainless steel housing	AISI/DIN	304/1.4301	304/1.4301			

### Ordering Information

Type	VAM016-A	VAM016-X	VAM025-A	VAM025-X	VAM040-A	VAM040-X
Part No.	253-500	253-501	253-502	253-503	253-504	253-505

### Spare Parts

Seal kit O-rings for one valve	299-001	299-006	299-011
Bellows cpl. Bellows & seal kit	299-002	299-007	299-012
Electronics cpl.	299-016	299-016	299-016
Linear solenoid cpl.	299-017	299-018	299-019

**VAM016 ... 040-A/X** - continued

**Specifications**

Type		VAM016-A	VAM016-X	VAM025-A	VAM025-X	VAM040-A	VAM040-X
Cycle life	Mio cycles	2		2		2	
Conductance for molecular flow	l/s	4		13		35	
Tightness	mbar l/s	1 x 10 <sup>-9</sup>		1 x 10 <sup>-9</sup>		1 x 10 <sup>-9</sup>	
Operating pressure min. / max	mbar / bar	10 <sup>-8</sup> / 1.3		10 <sup>-8</sup> / 1.3		10 <sup>-8</sup> / 1.3	
Pressure max.	bar	3		3		1	
Pressure difference							
In closing direction	bar	1.3		1.3		1.3	
In opening direction	bar	1.3		1.3		1	
Opens to a pressure difference of	bar	1.3		1.3		1.3	
Ambient temperature	°C	0 ... 50		0 ... 50		0 ... 50	
Bakeout temperature							
Housing	°C	120		120		120	
Actuator, idle	°C	50		50		50	
Supply voltage	V	90 ... 264		90 ... 264		90 ... 264	
Frequency	Hz	47 ... 63		47 ... 63		47 ... 63	
Pickup power	W	405		416		367	
Holding power	W	8.1		8.3		7.5	
Power consumption	W	400		400		400	
Closing time	ms	100		120		230	
Opening time	ms	220		220		650	
Dead time	ms	40		140		450	
Switching frequency							
At 40°C	1/min	30		30		30	
At 50°C	1/min	20		20		20	
Control voltage	V DC	15 ... 30		15 ... 30		15 ... 30	
Power consumption	mA	1.5 ... 5		1.5 ... 5		1.5 ... 5	
Position indicator							
Switching voltage	V DC	15 ... 30		15 ... 30		15 ... 30	
Switching current	mA	100		100		100	
Materials							
Housing		EN-AW 6060	1.4301	EN-AW 6060	1.4301	EN-AW 6060	1.4301
Bellows		stainless steel		stainless steel		stainless steel	
Seals		FPM		FPM		FPM	
Degree of protection		IP 54		IP 54		IP 54	
Mounting orientation		any		any		any	
Weight	kg	1.1	1.2	1.9	2.0	4.3	4.4

# VAM016 ... 040-A/X - continued

## Dimensions

Aluminum housing [mm]

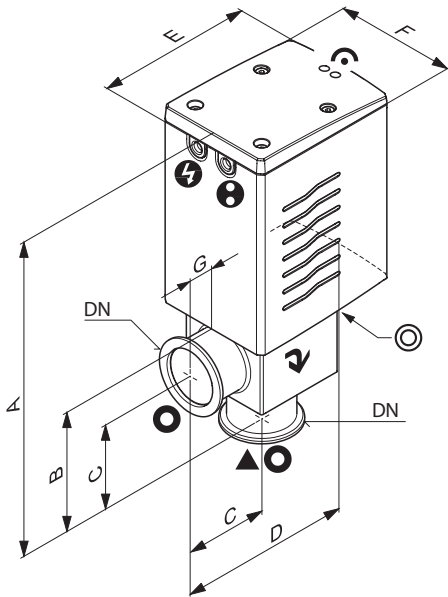

DN	A	B	C	D	E	F	G
DN 16 ISO-KF	170.9	51.4	40	96	86	59	10
DN 25 ISO-KF	193	64.9	50	112.7	97.3	70	15.4
DN 40 ISO-KF	246	92.9	65	139	119.5	90	19.5

- ⊙ Leak detection opening
- ⊕ Position indicator connection
- Protective lid
- ▼ Valve seat site
- ⚡ Electrical connection
- ⦿ Visual position indicator
- ↻ Flow direction

Stainless steel housing [mm]

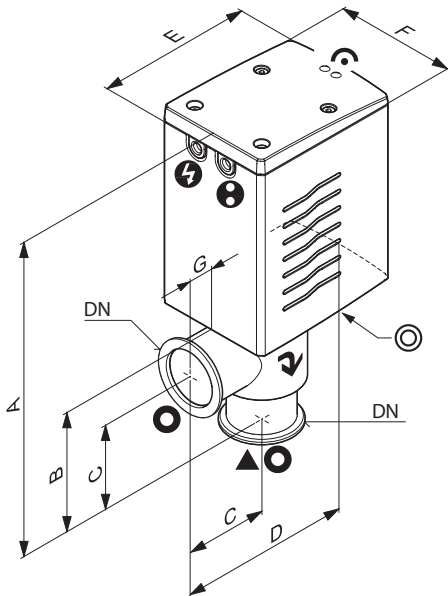

DN	A	B	C	D	E	F	G
DN 16 ISO-KF	172.9	53.4	40	96	86	59	10
DN 25 ISO-KF	196.4	68.3	50	112.7	97.3	70	15.4
DN 40 ISO-KF	249	95.9	65	139	119.5	90	19.5

- ⊙ Leak detection opening
- ⊕ Position indicator connection
- Protective lid
- ▼ Valve seat site
- ⚡ Electrical connection
- ⦿ Visual position indicator
- ↻ Flow direction

# Angle Valves ( VAH, VAP )

## DN 63

### Manually Actuated

- Spindle drive with hand wheel
- Smooth opening
- Visual position indicator

### Pneumatically Actuated

- Visual indication for open and closed position
- Electrical position indicator for open and closed position
- For system manufacturers without pilot valve



### Selection Data

Angle valve		DN 63 ISO-K	DN 63 ISO-K
Housing material	AISI/DIN	aluminum -/3.2373	stainless steel 304/1.4301

### Ordering Information - Manually Actuated

Type		<b>VAH063-A</b>	<b>VAH063-X</b>
Angle valve	Part No.	<b>250-470</b>	<b>250-475</b>

### Spare Parts

Seal set		<b>215-251</b>	<b>215-251</b>
Bellows set for manually actuated valves		<b>215-254</b>	<b>215-254</b>

### Specifications - Manually Actuated

Service life	cycles	10'000	10'000
Conductance for molecular flow	l/s	140	140
Tightness	mbar l/s	$1 \times 10^{-9}$	$1 \times 10^{-9}$
Pressure absolute, min. / max.	mbar / bar	$10^{-8}$ / 1,5	$10^{-8}$ / 1,5
Pressure resistance	bar (abs.)	4	4
Differential pressure in closing / opening direction	bar	1.5 / 1.5	1.5 / 1.5
Opens to a pressure difference of	bar	1.5	1.5
Ambient temperature	°C	5 – 60	5 – 60
Mounting orientation		any	any
Seals		FPM	FPM
Weight	kg	3.6	6.5

## DN 63 - continued

## Selection Data

Angle valve		DN 63 ISO-K	DN 63 ISO-K
Housing material	AISI/DIN	aluminum —/3.2373	stainless steel 304/1.4301

## Ordering Information - Pneumatically Actuated

Type		VAP063-A	VAP063-X
Angle valve w/o pilot valve, with position indicator		<b>250-404</b>	<b>250-414</b>
Valve with pilot valve, with position indicator			
24 V DC	Part No.	<b>250-400</b>	<b>250-410</b>
24 V AC	Part No.	<b>250-401</b>	<b>250-411</b>
100 – 115 V AC	Part No.	<b>250-402</b>	<b>250-412</b>
200 – 240 V AC	Part No.	<b>250-403</b>	<b>250-413</b>

## Spare Parts

Seal set	<b>215-521</b>	<b>215-251</b>
Bellows set for pneumatically actuated valves	<b>215-253</b>	<b>215-253</b>

## Specifications - Pneumatically Actuated

Service life	Mio cycles	1.5	1.5
Conductance for molecular flow	l/s	140	140
Tightness	mbar l/s	1 x 10 <sup>-9</sup>	1 x 10 <sup>-9</sup>
Pressure, absolute, min. / max.	mbar / bar	10 <sup>-8</sup> / 1,5	10 <sup>-8</sup> / 1,5
Pressure resistance	bar (abs.)	4	4
Differential pressure in closing / opening direction	bar	1.5 / 1.5	1.5 / 1.5
Opens to a pressure difference of	bar	1.5	1.5
Ambient temperature	°C	5 – 60	5 – 60
Switching frequency	1/min	60	60
Closing time	ms	300	300
Opening time	ms	300	300
Electrical position indicator load capacity	VAC / A	250 / 0.125	250 / 0.125
	VDC / A	50 / 0.25	50 / 0.25
Compressed air, overpressure	bar	4 – 8	4 – 8
Air cylinder volume	cm <sup>3</sup>	75	75
Mounting orientation		any	any
Seals		FPM	FPM
Weight	kg	4.0	6.8



### Dimensions - Manually Actuated

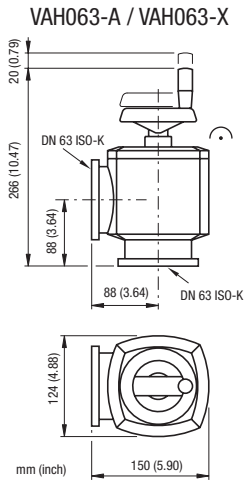

### Dimensions - Pneumatically Actuated

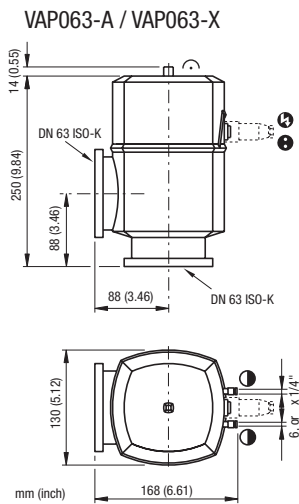

Angle valve with and without pilot valve,  
with position indicator

# Angle Valves ( VAH, VAP )

## DN 100

### Manually Actuated

- Bellows feedthrough
- Spindle drive with hand wheel
- Smooth opening
- Visual position indication

### Pneumatically Actuated

- Bellows feedthrough
- Visual indication of the open and closed position
- Electrical position indicator for open and closed position
- For system manufacturers without pilot valve



### Selection Data

Angle valve		DN 100 ISO-K	DN 100 ISO-K
Housing material	AISI(AA)/DIN	aluminum - / 3.2373	stainless steel 303 / 1.4305

### Ordering Information - Manually Actuated

Type	<b>VAH100-A</b>	<b>VAH100-X</b>
Part No.	250-480	250-485

### Spare Parts

Seal set	<b>215-271</b>	<b>215-271</b>
Bellows set for manually actuated valves	<b>215-274</b>	<b>215-274</b>

### Specifications - Manually Actuated

Service life	Cycles	10'000	10'000
Conductance for molecular flow	l/s	330	330
Tightness	mbar l/s	1 x 10 <sup>-9</sup>	1 x 10 <sup>-9</sup>
Pressure absolute, min. / max.	mbar / bar	10 <sup>-3</sup> / 1.5	10 <sup>-3</sup> / 1.5
Pressure resistance	bar (abs.)	4	4
Differential pressure in closing / opening direction	bar	1.5 / 1.5	1.5 / 1.5
Opens to a pressure difference of	bar	1.5	1.5
Ambient temperature	°C	5 – 60	5 – 60
Mounting orientation		any	any
Seals		FPM	FPM
Weight	kg	6.1	11.1

## DN 100 – continued

### Selection Data

Angle valve		DN 100 ISO-K	DN 100 ISO-K —
Housing material	AISI (AA) /DIN	aluminum - / 3.2373	stainless steel 303 / 1.4305

### Ordering Information - Pneumatically Actuated

Type	VAP100-A	VAP100-X
Angle valve w/o pilot valve, with position indicator	<b>250-424</b>	<b>250-434</b>
Valve with pilot valve, with position indicator		
24 V DC	Part No. <b>250-420</b>	<b>250-430</b>
24 V AC	Part No. <b>250-421</b>	<b>250-431</b>
100 – 115 V AC	Part No. <b>250-422</b>	<b>250-432</b>
200 – 240 V AC	Part No. <b>250-423</b>	<b>250-433</b>

### Spare Parts

Seal set	<b>215-571</b>	<b>215-271</b>
Bellows set for pneumatically actuated valves	<b>215-273</b>	<b>215-273</b>

### Specifications - Pneumatically Actuated

Service life	Mio cycles	1.5	1.5
Conductance for molecular flow	l/s	330	330
Tightness	mbar l/s	1 x 10 <sup>-9</sup>	1 x 10 <sup>-9</sup>
Pressure, absolute, min. / max.	mbar / bar	10 <sup>-3</sup> / 1.5	10 <sup>-3</sup> / 1.5
Resistance to pressure	bar (abs.)	4	4
Differential pressure			
In closing / opening direction	bar	1.5 / 1.5	1.5 / 1.5
Opens to a pressure difference of	bar	1.5	1.5
Ambient Temperature	°C	5 ... 60	5 ... 60
Switching frequency	1/min	60	60
Closing time	ms	400	400
Opening time	ms	400	400
Electrical position indicator,	V AC / A	250 / 0.125	250 / 0.125
Load capacity	V DC / A	50 / 0.25	50 / 0.25
Compressed air, overpressure	bar	4 – 8	4 – 8
Air cylinder volume	cm <sup>3</sup>	195	195
Mounting orientation		any	any
Seals		FPM	FPM
Weight	kg	6.7	11.7

# DN 100 - continued

## Dimensions - Manually Actuated

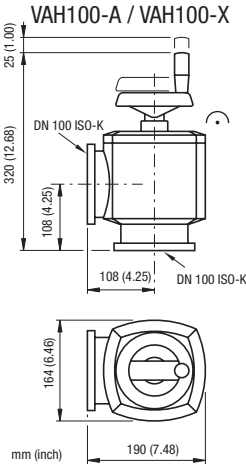

## Dimensions - Pneumatically Actuated

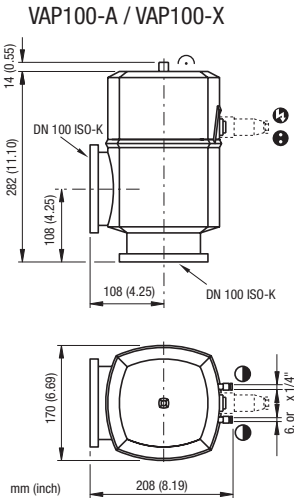

Angle valve with and without pilot valve,  
with position indicator

# Angle Valves ( VAP )

## DN 160

### Advantages

- Visual indication for open and closed position
- Electrical position indicator for open and closed position
- For system manufacturers without pilot valve



### Selection Data

Angle valve		DN 160 ISO-K
Housing material	AA/DIN	aluminum -/3.2373

### Ordering Information

Type		<b>VAP160-A</b>
Angle valve w/o pilot valve, with position indicator		<b>250-444</b>
Valve with pilot valve, with position indicator		
24 V DC	Part No.	<b>250-440</b>
24 V AC	Part No.	<b>250-441</b>
100 – 115 V AC	Part No.	<b>250-442</b>
200 – 240 V AC	Part No.	<b>250-443</b>

### Spare Parts

Seal set		<b>215-291</b>
Bellows set for pneumatically actuated valves		<b>215-293</b>

### Specifications

Service life	Mio cycles	1.5
Conductance for molecular flow	l/s	800
Tightness	mbar l/s	$1 \times 10^{-9}$
Pressure, absolute, min. / max.	mbar / bar	$10^{-8}$ / 1,5
Pressure resistance	bar (abs.)	4
Differential pressure in closing / opening direction	bar	1.5 / 1.5
Opens to a pressure difference of	bar	1.5
Ambient Temperature	°C	5 – 60
Switching frequency	1/min	40
Closing time	ms	650
Opening time	ms	600
Electrical position indicator, load capacity	VAC / A VDC / A	250 / 0.125 50 / 0.25
Compressed air, overpressure	bar	4 – 8
Air cylinder volume	cm <sup>3</sup>	570
Mounting orientation		any
Seals		FPM
Weight	kg	11.4

# DN 160 - continued

## Dimensions

VAP160-A

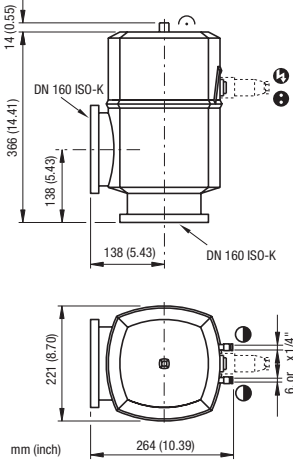

# Butterfly Valves Manually actuated

## VBH063 ... 160-X

### Advantages

- Three sizes available: DN 63, 100, 160
- Robust and compact design with low installation height
- High conductance all stainless steel housings
- Lateral gauge/valve flange connections standard
- FPM sealings
- Extremely long service lifetime



### Selection Data

Vacuum connection	DN 63 ISO-F	DN 100 ISO-F	DN 160 ISO-F
-------------------	-------------	--------------	--------------

### Ordering Information

Type	VBH063-X	VBH100-X	VBH160-X
	250-560	250-570	250-580

### Specifications

Lateral vacuum connections		DN 10 ISO-KF DN 16 ISO-KF	2 x DN 10 ISO-KF DN 25 ISO-KF	2 x DN 10 ISO-KF DN 25 ISO-KF
Cycle life	Cycles	100,000	100,000	100,000
Conductance for molecular flow	l/s	350	1000	3400
Tightness	mbar l/s	$1 \times 10^{-9}$	$1 \times 10^{-9}$	$1 \times 10^{-9}$
Pressure in either direction				
Static min. / max.	mbar / bar	$1 \times 10^{-8}$ / 10	$1 \times 10^{-8}$ / 10	$1 \times 10^{-8}$ / 10
Dynamic min. / max	mbar / bar	$1 \times 10^{-8}$ / 4	$1 \times 10^{-8}$ / 4	$1 \times 10^{-8}$ / 4
Pressure difference $\Delta p$				
In either direction	bar	4	4	4
Bakeout teperature housing	°C	150	150	150
Housing, shaft, valve plate	AISI / DIN	304 / 1.4301	304 / 1.4301	304 / 1.4301
Seals		FPM	FPM	FPM
Weight	kg	3.1	5.2	9.3

# VBH063 ... 160-X - continued

## Accessories

	VBH063	VBH100	VBH160
Connection elements X type	215-212	215-214	215-216

## Spare Parts

	VBH063	VBH100	VBH160
Seal kit X type	215-143	215-145	215-147

## Dimensions

**VBH063-X**

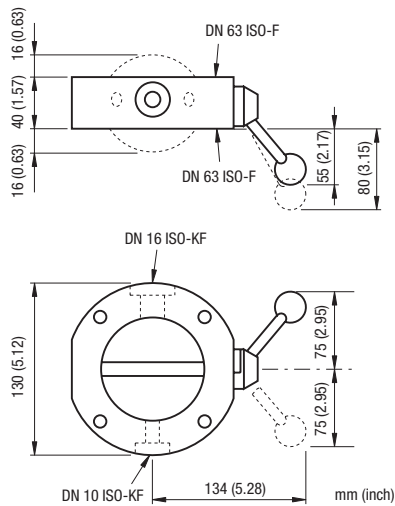

**VBH100-X**

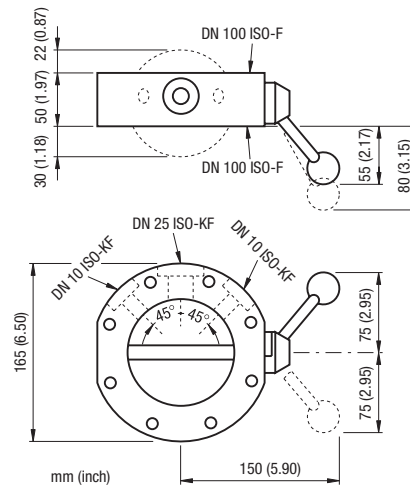

**VBH160-X**

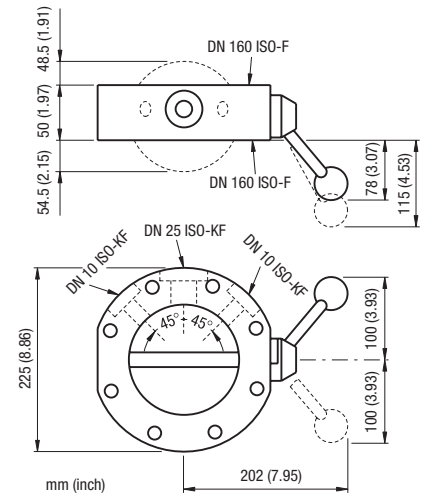



# Pneumatically Actuated Butterfly Valves ( VBP )

VBP063 ... 250-X/Z



## Advantages

- Four sizes available: DN 63, 100, 160, 250
- Robust and compact design with low installation height
- High conductance all stainless steel housings
- With or without lateral gauge/valve flange connections
- FPM sealings
- Extremely long service lifetime
- Direct pneumatic actuation or via pilot valve
- Electrical and visual position indicator

**VBP063 ... 250-X/Z** - continued

**Selection Data**

Vacuum connection	DN 63 ISO-F	DN 100 ISO-F	DN 160 ISO-F	DN 250 ISO-K
Lateral vacuum connections	DN 10 ISO-KF DN 16 ISO-KF	2 x DN 10 ISO-KF DN 25 ISO-KF	2 x DN 10 ISO-KF DN 25 ISO-KF	2 x DN 10 ISO-KF DN 25 ISO-KF DN 40 ISO-KF

**Ordering Information**
**With lateral vacuum connections**

<b>Type</b>	<b>VBP063-X</b>	<b>VBP100-X</b>	<b>VBP160-X</b>	<b>VBP250-X</b>
	<b>253-100</b>	<b>253-120</b>	<b>253-140</b>	<b>253-160</b>

**Without lateral vacuum connections**

<b>Type</b>	<b>VBP063-Z</b>	<b>VBP100-Z</b>	<b>VBP160-Z</b>	<b>VBP250-Z</b>
	<b>253-110</b>	<b>253-130</b>	<b>253-150</b>	<b>253-170</b>

**Specifications**

Cycle life	Cycles	1,000,000	1,500,000	1,500,000	1,000,000
Conductance for molecular flow					
X types	l/s	350	1000	3400	8200
Z types	l/s	400	1400	4000	8200
Tightness	mbar l/s	$1 \times 10^{-9}$	$1 \times 10^{-9}$	$1 \times 10^{-9}$	$1 \times 10^{-9}$
Pressure in either direction					
Static min. / max.	mbar / bar	$1 \times 10^{-8}$ / 10	$1 \times 10^{-8}$ / 10	$1 \times 10^{-8}$ / 10	$1 \times 10^{-8}$ / 10
Dynamic min. / max	mbar / bar	$1 \times 10^{-8}$ / 4	$1 \times 10^{-8}$ / 4	$1 \times 10^{-8}$ / 4	$1 \times 10^{-8}$ / 4
Pressure difference $\Delta p$					
In either direction	bar	4	4	4	4
Bakeout temperature housing	°C	150	150	150	150
Housing, shaft, valve plate	AISI / DIN	304 / 1.4301	304 / 1.4301	304 / 1.4301	304 / 1.4301
Seals		FPM	FPM	FPM	FPM
Weight					
X types	kg	3.8	6.5	10	15.7
Z types	kg	3.5	5	8	16

## VBP063 ... 250-X/Z - continued

### Spare Parts

	VBP063	VBP100	VBP160	VBP250
Seal kit				
X type	215-143	215-145	215-147	215-149
Z type	215-144	215-146	215-148	215-149
Actuator	253-181	253-182	253-182	253-183

### Accessories

	VBP063	VBP100	VBP160	VBP250
Position indicator	253-180	253-180	253-180	253-180
Pilot valve				
230 V AC / 50 Hz	215-131	215-131	215-131	215-131
115 V AC / 60 Hz	215-132	215-132	215-132	215-132
24 V AC / 50 Hz	215-133	215-133	215-133	215-133
24 V DC / 50 Hz	215-134	215-134	215-134	215-134
Connection elements				
X type	215-212	215-214	215-216	212-225
Z type	215-213	215-215	215-217	212-225





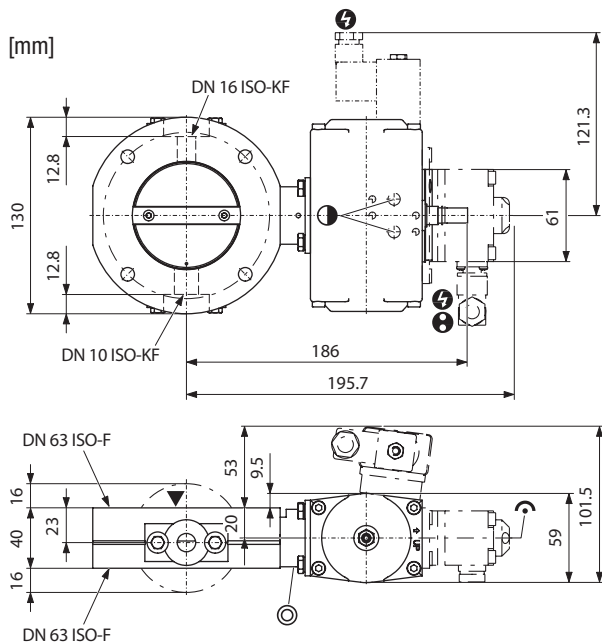

### Dimensions

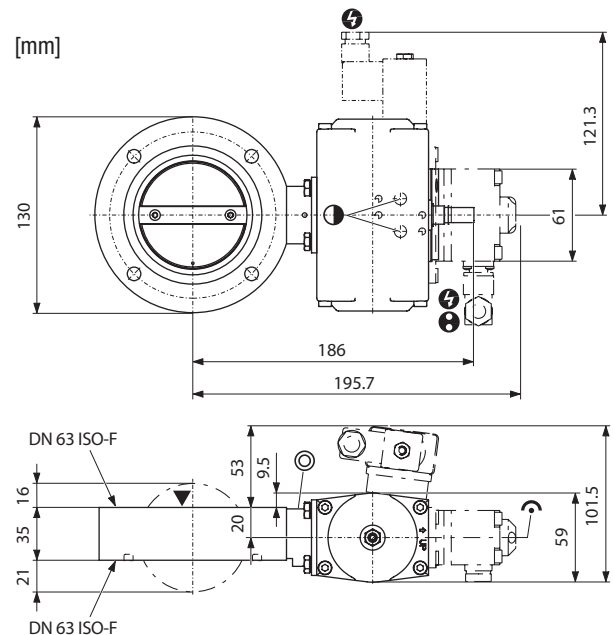
VBP063-X



VBP063-Z



-  Compressed air connection
-  Position indicator connection
-  Visual position indicator
-  Electrical connection
-  Valve seat site
-  Leak detection opening

# VBP063 ... 250-X/Z - continued

## Dimensions

**VBP100-X**

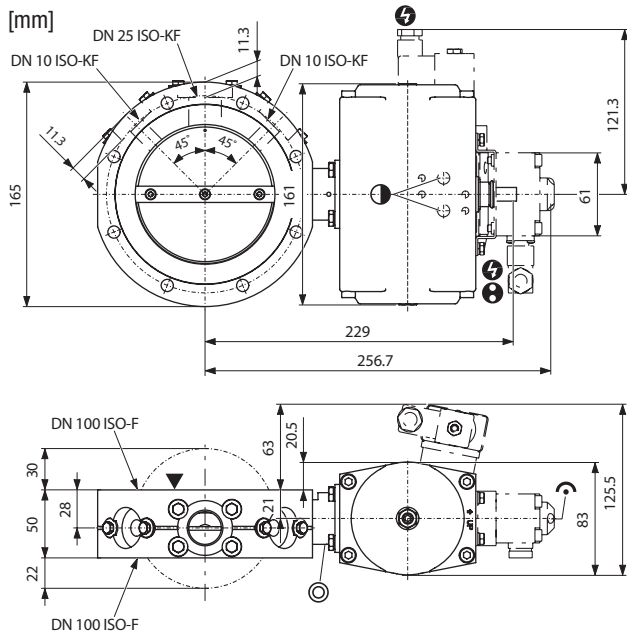

**VBP100-Z**

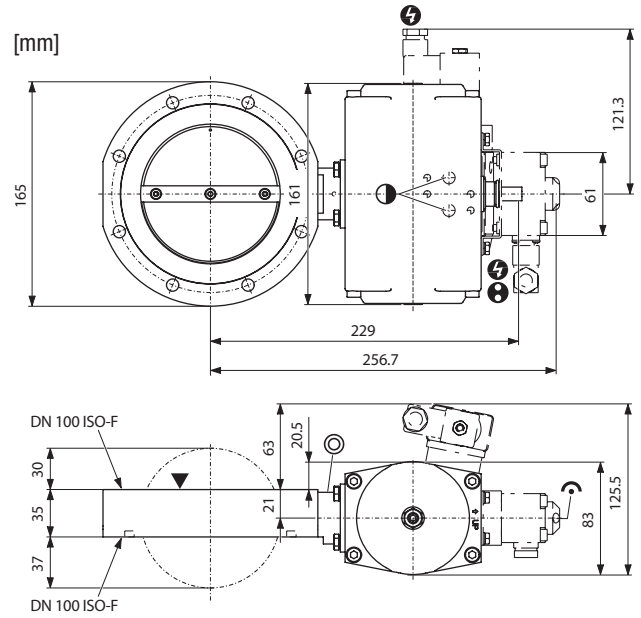

- Compressed air connection
- Position indicator connection
- ⚡ Electrical connection
- ◐ Visual position indicator
- ▼ Valve seat site
- ⊙ Leak detection opening

# VBP063 ... 250-X/Z - continued

## Dimensions

**VBP160-X**

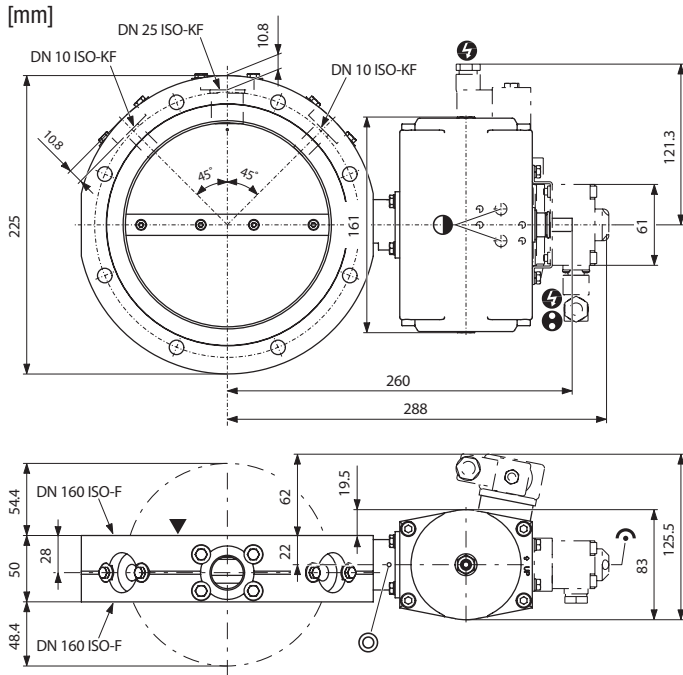

**VBP160-Z**

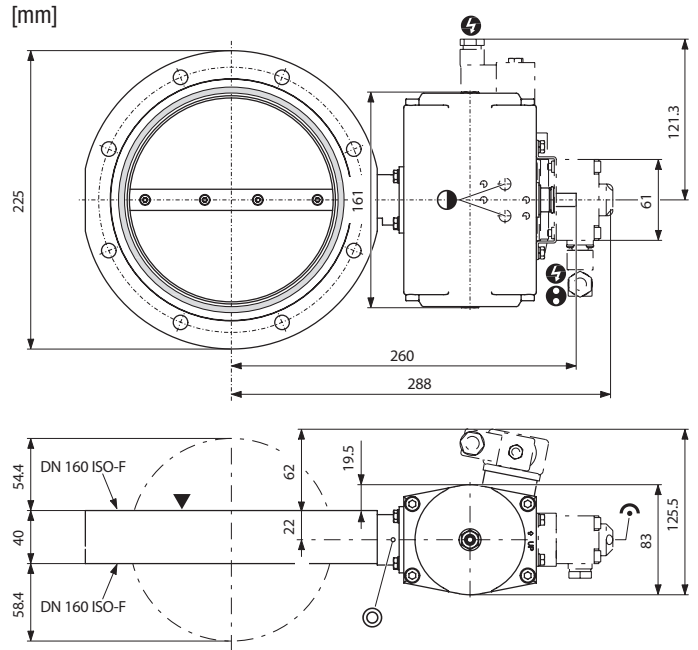

- Compressed air connection
- ⚡ Electrical connection
- ⊕ Position indicator connection
- ▼ Valve seat site
- 👁 Visual position indicator
- ⊙ Leak detection opening

## VBP063 ... 250-X/Z - continued





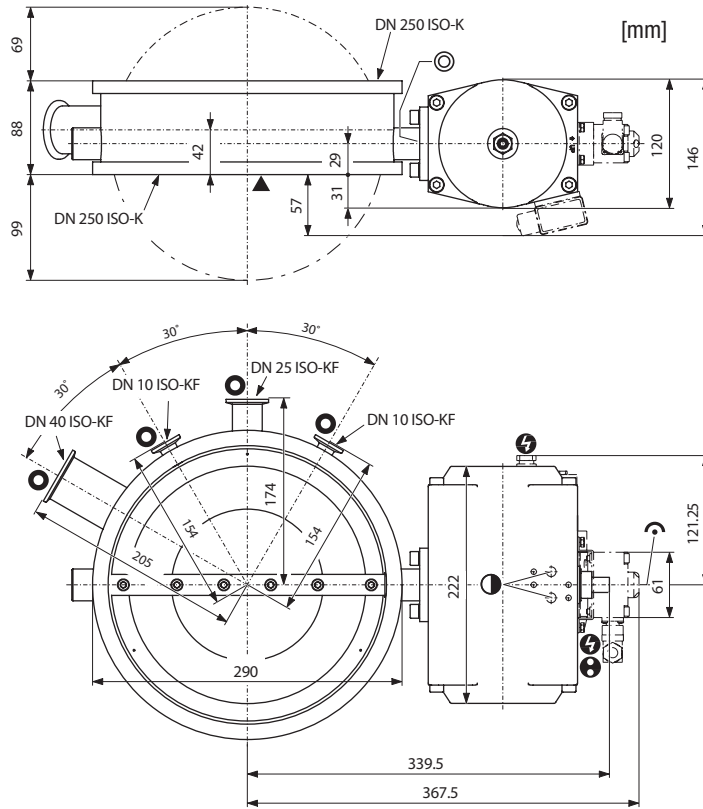

### Dimensions

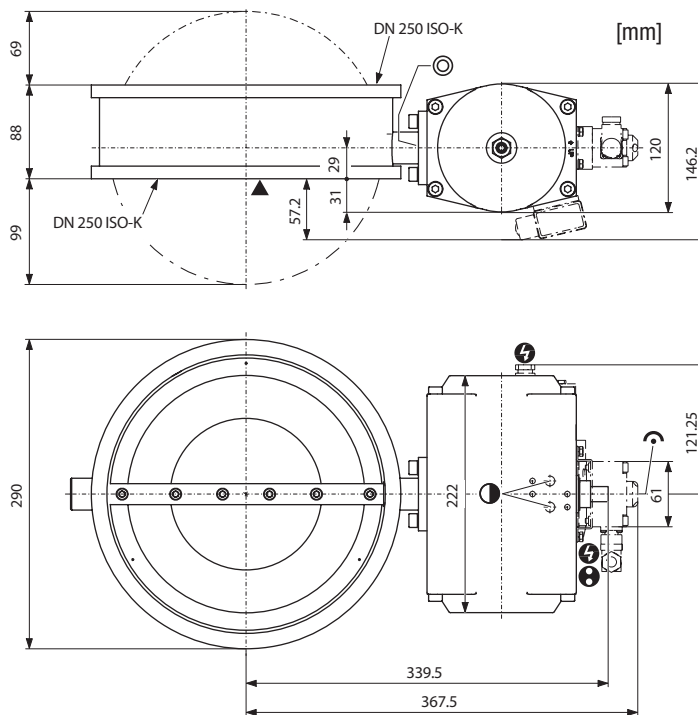
VBP250-X



VBP250-Z



-  Compressed air connection
-  Electrical connection
-  Position indicator connection
-  Valve seat site
-  Visual position indicator
-  Leak detection opening

# Manually Actuated Coarse Gas Dosing Valve

## VDH010-A

### Advantages

- For admitting a reproducible flow of gas into a vacuum chamber



### Selection Data

Vacuum connection	DN 10 ISO-KF	
Gas flow, controllable		
Min.	mbar l/s	40
Max.	mbar l/s	1700

### Ordering Information

Type	<b>VDH010-A</b>
Part No.	<b>250-520</b>

### Specifications

Tightness	mbar l/s	$1 \times 10^{-8}$
Pressure range	mbar to bar	$1 \times 10^{-7}$ to 4
Bakeout temperature	°C	100
Housing	aluminum	
Seals	FPM	
Weight	kg	0.2

### Spare Parts

Seal set	<b>215-207</b>
----------	----------------

### Dimensions

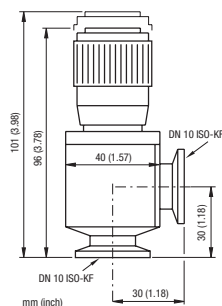

# Manually Actuated Dosing and Shut-Off Valve

## VDH016-X

### Advantages

- Very wide control range
- Optimal control characteristics
- Digital display
- Excellent reproducibility
- Extremely small dead volume
- Integrated shut-off valve
- Closing without change of flow setting



### Selection Data

Vacuum connection		DN 16 ISO-KF
Gas flow, controllable		
Min.	mbar/l/s	$5 \times 10^{-6}$
Max.	mbar/l/s	1000

### Ordering Information

Type	<b>VDH016-X</b>
Part No.	<b>250-500</b>

### Specifications

Tightness	mbar/l/s	$1 \times 10^{-9}$
Differential pressure	bar	2.5
Dead volume	cm <sup>3</sup>	0.032
Operating temperature	°C	80
Bakeout temperature, flanges	°C	150
Housing, needle, filter		stainless steel
Dosing sleeve		Fluorplastomer
Seal		FPM
Weight	kg	0.4

### Accessories

Filter, vacuum side		
590 mbar l/s	Part No.	<b>215-462</b>
1250 mbar l/s	Part No.	<b>215-463</b>



## VDH016-X - continued

### Dimensions

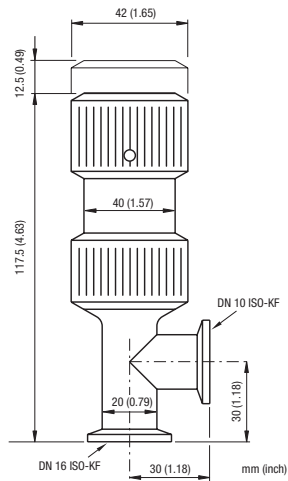

# All-Metal Dosing Valves and System

## VDH040-U / VDE040-U / VCE500

### Advantages

- Minimal dead volume
- Controlled routing of the gas flow using capillaries
- Operating temperature 200°C
- Control of total pressure or gas flow
- Automatic control in conjunction with VDE40-U and VCE500



### Selection Data

Actuator	manual	manual and thermo-mechanical in conjunction with VCE500
----------	--------	--

### Ordering Information VDH040-U / VDE040-U

Type	VDH040-U	VDE040-U
Valve	250-700	250-720

### Specifications

Connection flange			
Input		DN 16 CF-R	DN 16 CF-R
Output		DN 40 CF-F	DN 40 CF-F
Gas flow, controllable			
Min.	mbar/l/s	$1 \times 10^{-10}$	$1 \times 10^{-10}$
Max.	mbar/l/s	600	100 <sup>1)</sup>
Tightness	mbar/l/s	$1 \times 10^{-11}$	$1 \times 10^{-11}$
Pressure min./max. (absolute)	mbar	$1 \times 10^{-11}/30$	$1 \times 10^{-10}/30$
Conductance for molecular flow	l/s	0.7	0.7
Operating temperature	°C	200	200
Bakeout temperature	°C	350	350 <sup>2)</sup>
Valve plate		sapphire	sapphire
Valve seat		copper	copper
Housing		stainless steel	stainless steel
Weight	kg	1.4	1.4

<sup>1)</sup> Can be regulated with the VCE500 Controller

<sup>2)</sup> Without cable

## VDH040-U / VDE040-U / VCE500 - continued

### Accessories

Type	VDH040-U	VDE040-U
Capillary complete, vacuum side, 1m	215-708	215-708
Heater, 200°C	250-701	250-701
Adapter DN 40/16 CF	213-071	213-071

### Options

Tool kit	215-707	215-707
----------	---------	---------

### Spare Parts

Valve plate, sapphire	215-715	215-715
Valve seat		
Standard	215-716	215-716
Gold plated	215-717	215-717

### Ordering Information VCE500

Controller for VDE040-U	VCE500
Part No.	250-920

### Specifications

Power supply	V	115 / 230
Frequency	Hz	50 ... 60
Power consumption	VA	20
Regulating characteristic		proportional-integral (PI)
Reset time	s	2 ... 30
Proportional gain		2 ... 1000
Internal nominal value		
Scale divisions		0 ... 1000
External nominal value	VCD/100 kΩ	0 ... +10
Protection class		IP 20

### Cable

Standard, 80°C		
3 m	Part No.	202-914
12 m (max. cable length)	Part No.	202-916
Extension, 200°C		
2 m	Part No.	202-924

## VDH040-U / VDE040-U / VCE500 - continued

### Dimensions

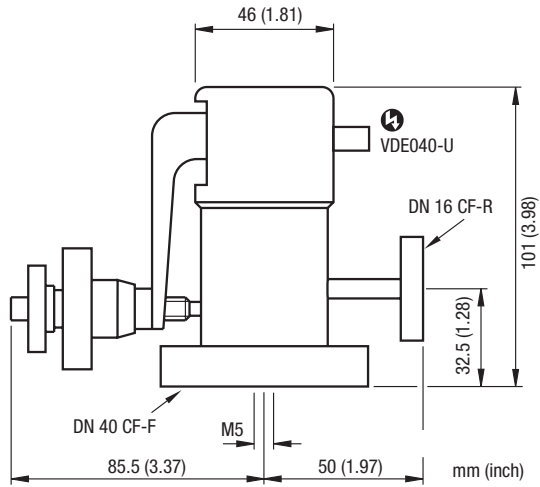

# Gas Dosing Systems

## User Advantages

- Higher yield
- Optimized cycle time
- Excellent reproducibility
- Easy system integration

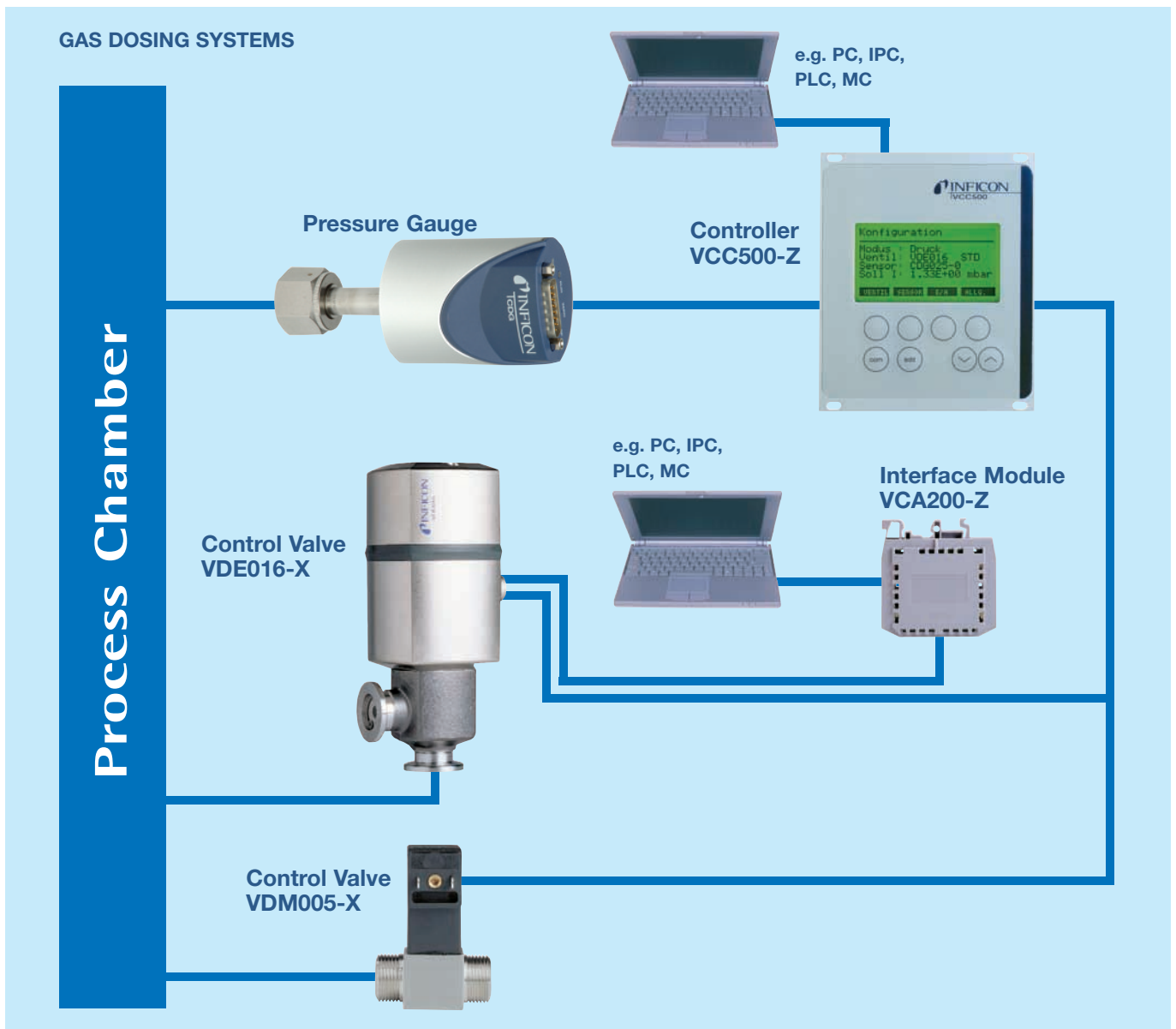

# Solenoid Control Valves

## Control Valve VDM005A-X

### User Advantages

- Fast response time
- Excellent control characteristics
- High reproducibility and repeatability
- Stainless steel housing
- Closes automatically in case of power failure
- Smooth solenoid drive
- Optional flange connection
- Very compact design

### Selection Data

Vacuum connection	DN 5 mm / M 14 x 1
Control range	1 ... 100 %FS 20 ... 70 mA
Pressure range (outlet)	$1 \times 10^{-9}$ mbar
Pressure max. in closing direction	2 bar
Response time	<30 ms

### Ordering Information

Type	VDM005A-X
10 sccm	<b>250-508</b>
50 sccm	<b>250-509</b>
100 sccm	<b>250-510</b>
500 sccm	<b>250-511</b>
1000 sccm	<b>250-512</b>
5000 sccm	<b>250-513</b>

### Cable VCC - VDM

3m	<b>216-160</b>
5m	<b>216-161</b>
10m	<b>216-162</b>
15m	<b>216-163</b>
20m	<b>216-164</b>
25m	<b>216-165</b>

### Accessories

DN 10 ISO-KF flange connection	<b>250-080</b>
Pipe OD 1/4" connection	<b>250-085</b>
Pipe OD 6 mm connection	<b>250-086</b>
Other connections	<b>on request</b>
Filter set (10 pcs.)	<b>215-519</b>



### Technical Data

Tightness	$1 \times 10^{-9}$ mbar l/s
Actuator	solenoid
Controller	VCC500-Z
Ambient temperature	+5 ... +50 °C
Duty cycle	100 %
Protection type	IP51
Supply voltage	0 ... 24 V DC
Power consumption	2.5 W max.
Housing	stainless steel
Seals	FPM
Weight (without connection)	96 g

### Technical Drawing

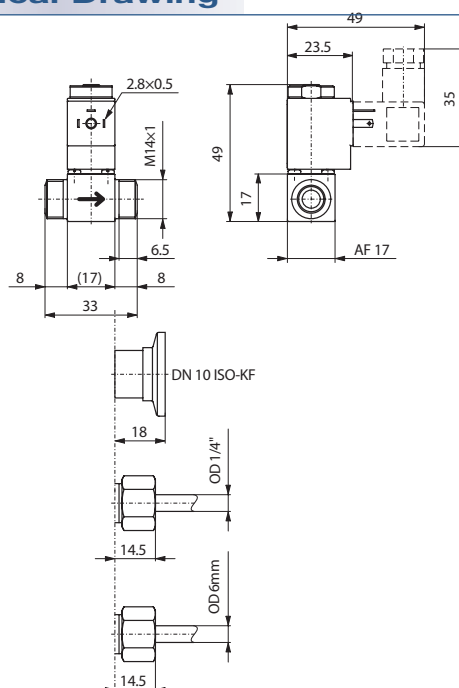

# Control Valve VDE016-X

## User Advantages

- Broad control range
- Excellent reproducibility
- Status information and commands via digital interface
- Withstands corrosive gases - stainless steel / FPM
- Combined with the VCC500-Z controller, the valve closes automatically in case of a power failure



## Selection Data

Vacuum connection	DN 16 ISO-KF
Gas flow, controllable	
Min.	5 x 10 <sup>-6</sup> mbar l/s
Max.	1250 mbar l/s
Pressure absolute	
Min.	1 x 10 <sup>-3</sup> mbar
Max.	2.5 bar
Closing / opening time	3 / 4 s

## Ordering Information<sup>1)</sup>

Type	<b>VDE016-X</b>
Part No.	<b>250-505</b>

1) Connector included

## Cable VCC - VDE

3 m	Part No.	<b>216-150</b>
5 m	Part No.	<b>216-151</b>
10 m	Part No.	<b>216-152</b>
15 m	Part No.	<b>216-153</b>
20 m	Part No.	<b>216-154</b>
25 m	Part No.	<b>216-155</b>

## Technical Data

Tightness	1 x 10 <sup>-9</sup> mbar l/s
Actuator	Stepper motor
Control	
Digital	VCC500-Z, VCA200-Z
Analog	0 ... 10 V DC
Ambient temperature	5 ... 40 °C
Supply	24 V DC / 12 VA
Housing	stainless steel
Dosing sleeve	fluorplastomer
Seals	FPM
Weight <sup>1)</sup>	0.5 kg

1) Connector included

## Technical Drawing

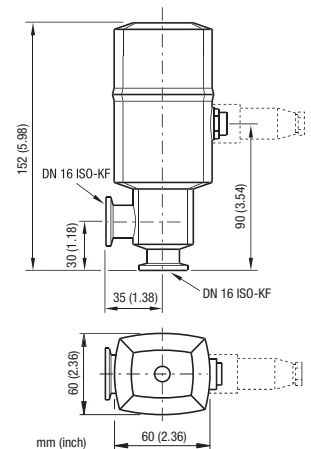

## Controller VCC500-Z

### User Advantages

- Simple operation - user friendly LCD display and function keys
- Analog/digital inputs, outputs and interfaces
- 99 PI pre-programmed control adjustments for quick and easy operation
- Adjustable PID control algorithm
- Wide variety of pre-programmed pressure gauges



### Selection Data

Analog input	0 ... 10 V DC nominal pressure, gas flow
Analog output	0 ... 10 V DC pressure, valve position

### Ordering Information<sup>1)</sup>

Type	<b>VCC500-Z</b>
Part No.	<b>250-900</b>

### Technical Data

Operating modes	Pressure control Gas flow adjustment
8 available digital inputs	Flow adjustment, opening/closing the valve, switching between pressure and gas flow control
8 available digital outputs	Valve position indication, setpoint status reached, status messages - sensor, valve, pressure control upstream and downstream
Features	Switching on after power failure Output "nominal value reached", adjustable tolerance
Units	mbar, Pa, Torr, mV
Languages	English, German
Interfaces	RS232C, RS485
Controller types	Auto = PI - selectable control speed steps 1-99 PID = PID - user definable parameters
Control accuracy	5 % FS sensors
Display accuracy	0.2 % FS sensor
Supply	
Voltage	90 ... 250 V AC
Consumption	50 VA
Weight	1.65 kg

### Technical Drawing

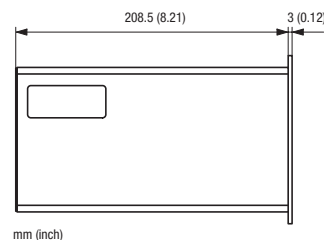
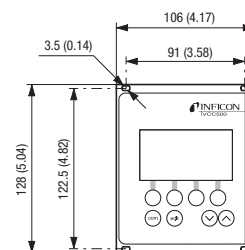



## Interface Module VCA200-Z

### User Advantages

- Easy and economic system integration
- Connects an RS232C interface to the digital interface of the Control Valve VDE016-X
- Inquiry of status and valve position

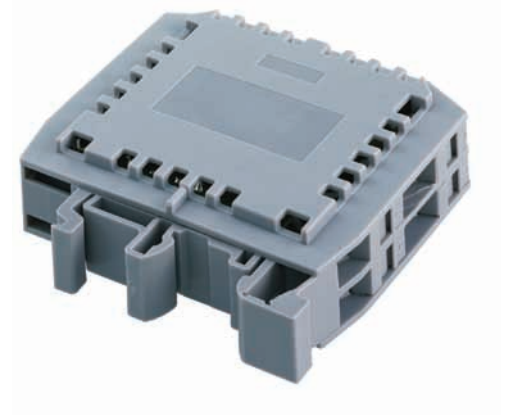

### Selection Data

Interface	RS232C
Supply	24 VDC / 0.5 A

### Ordering Information

Type	<b>VCA200-Z</b>
Part No.	<b>250-915</b>

### Technical Data

Installation	DIN mounting rail (symmetric or asymmetric)
Connection	terminals
Ambient temperature	5 ... 50°C
Weight	40 g

### Technical Drawing

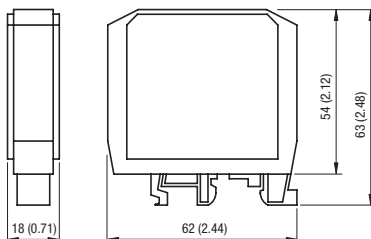

# Solenoid Control Valve

## Control Valve VDM005A-X



The INFICON Solenoid Control Valve VDM005A-X offers a fast and reproducible upstream pressure control. A newly designed solenoid control mechanism allows smooth control and provides excellent repeatability and reproducibility. The VDM005A-X is the successor to the VDM005-X and can be used as a drop in replacement, as the electrical and vacuum connections are exactly the same.

### User Advantages

- Fast response time
- Excellent control characteristics
- High reproducibility and repeatability
- Stainless steel housing
- Closes automatically in case of power failure
- Smooth solenoid drive
- Optional flange connection
- Very compact design

### Applications

- Upstream pressure control for coating processes
- General gas inlet for rough and high vacuum systems

### Ordering Information

Type	VDM005A-X
10 sccm	250-508
50 sccm	250-509
100 sccm	250-510
500 sccm	250-511
1000 sccm	250-512
5000 sccm	250-513

### Accessories

DN 10 ISO-KF flange connection	250-080
Pipe OD 1/4" connection	250-085
Pipe OD 6 mm connection	250-086
Other connections	on request
Filter set (10 pcs.)	215-519

## CONTROL VALVE VDM005A-X - continued

### Specifications

			VDM005A-X
Actuator			solenoid
Control range	% FS		1 ... 100
	mA		20 ... 70
Tightness	mbar l/s		$1.0 \times 10^{-9}$
Pressure range (outlet)	mbar		$1.0 \times 10^{-8}$ ... 1000
Pressure, max.	in closing direction	bar	2
Temperature			
Operation (ambient)	°C		+5 ... +50
Bakeout (without supply voltage)	°C		+80
Supply voltage	V DC		0 ... 24
Power consumption	W		2.5
Response time	ms		< 30
Weight (without connection)	g		96
Materials exposed to vacuum			FPM, stainless steel
Protection type			IP51

### Dimensions

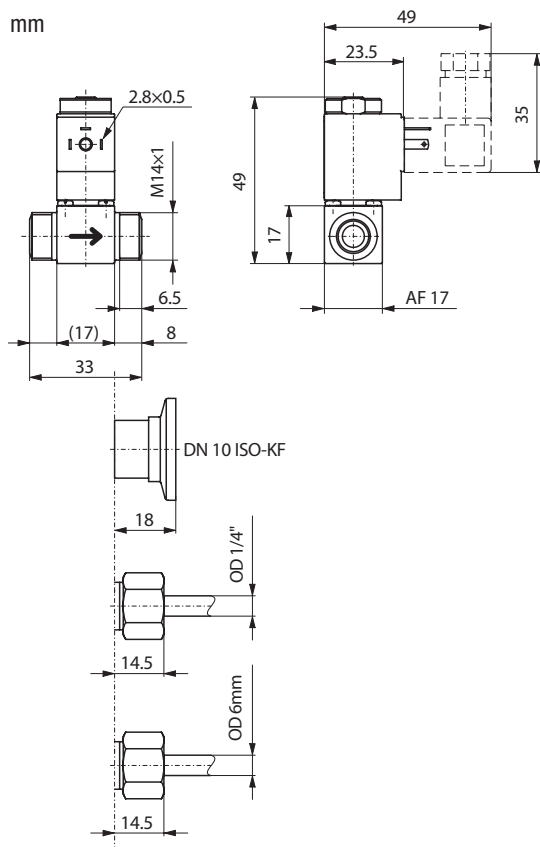

# Manually Actuated Angle Valves with CF-Flanges ( VAH )

## DN 16–63

### Standard

- For UHV and HV applications
- Bakeable at up to 180°C in open and closed position
- FPM sealed
- Maintenance-free

### All-metal

- For UHV applications
- Bakeable at up to 300°C in open and closed position
- Copper sealed
- Maintenance-free



### Selection Data

			STANDARD			ALL - METAL	
Vacuum connection		DN16 CF-R	DN40 CF-R	DN 63 CF-R	DN16 CF-R	DN40 CF-R	DN 63 CF-R
Tightness	mbar l/s	1 X 10 <sup>-10</sup>	1 X 10 <sup>-10</sup>	1 X 10 <sup>-10</sup>	5 X 10 <sup>-11</sup>	5 X 10 <sup>-11</sup>	5 X 10 <sup>-11</sup>
Bakeout temperature w/o hand wheel	°C	180	180	180	300	300	300

### Ordering Information

Type	VAH016-Z	VAH040-Z	VAH063-Z	VAH016-U	VAH040-U	VAH063-U
Part No.	250-731	250-736	250-741	250-730	250-735	250-740

### Specifications

Service life	cycles	50 000	50 000	50 000	1000	1000	1000
Conductance for molecular flow	l/s	3	38	100	3	38	100
Pressure (absolute) min. / max.	mbar/bar	1 x 10 <sup>-9</sup> / 4	1 x 10 <sup>-9</sup> / 4	1 x 10 <sup>-9</sup> / 4	1 x 10 <sup>-10</sup> / 4	1 x 10 <sup>-10</sup> / 4	1 x 10 <sup>-10</sup> / 4
Tightening torque	Nm	≤ 1	≤ 1.8	≤ 2.5	8-10	20-40	30-60
Heating and cooling rate	°C/min	—	—	—	4	4	2
Bellows, stainless steel AISI/DIN		321/1.4541	321/1.4541	321/1.4541	321/1.4541	321/1.4541	321/1.4541
Housing, stainless steel AISI/DIN		304/1.4301 welded	304/1.4301 welded	304/1.4301 welded	304/1.4301 welded	304/1.4301 welded	304/1.4301 welded
Valve plate, seal		FPM	FPM	FPM	copper	copper	copper
Valve plate, stainless steel AISI/DIN		304/1.4301	304/1.4301	304/1.4301	304/1.4301	304/1.4301	304/1.4301
Weight	kg	0.35	1.8	4.8	0.4	2.0	5.0

### Spare Parts

FPM seal, 10 pieces	Part No.	215-341	215-342	215-343	—	—	—
Copper seal, 2 pieces	Part No.	—	—	—	215-344	215-345	215-346

DN 16-63 - continued

Dimensions

VAH016-Z

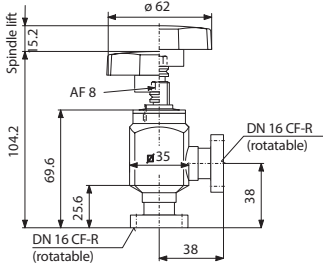

VAH040-Z

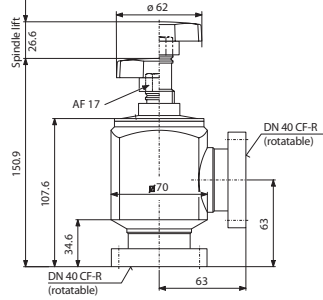

VAH063-Z

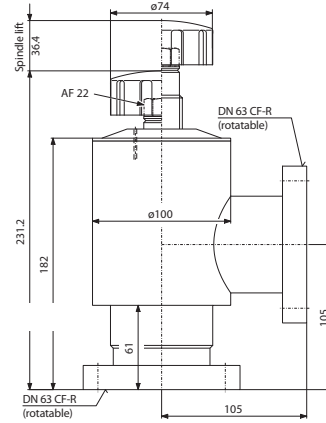

VAH016-U

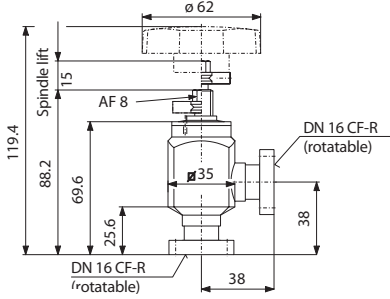

VAH040-U

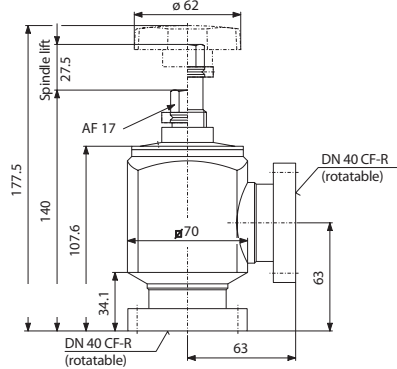

VAH063-U

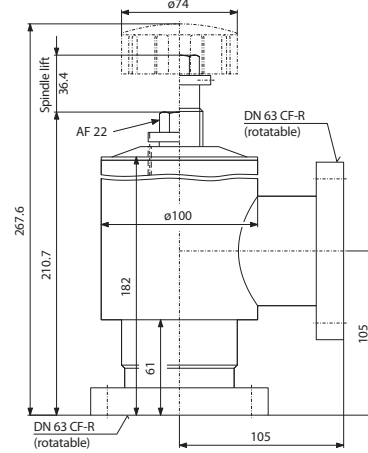

# Manually Actuated Venting Valve

## VVH010-A/X

### Advantages

- Simple opening and closing of the valve by loosening or tightening the screw cap



### Selection Data

Vacuum connection		DN 10 ISO-KF	DN 10 ISO-KF
Housing	AISI / DIN	aluminum / 3.0615	stainless steel 303 / 1.4305

### Ordering Information

Type	<b>VVH010-A</b>	<b>VVH010-X</b>
Part No.	<b>250-840</b>	<b>250-841</b>

### Specifications

Tightness	mbar l/s	$1 \times 10^{-9}$	$1 \times 10^{-9}$
Pressure (absolute)	mbar/bar	$1 \times 10^{-8} / 1$	$1 \times 10^{-8} / 1$
Valve plate		aluminum	stainless steel 304 / 1.4301
Screw cap		brass nickel-plated	brass nickel-plated
Seal		FPM	FPM
Weight	kg	0.1	0.15

### Spare Parts

O-ring	<b>B 4070 207 PV</b>	<b>B 4070 207 PV</b>
--------	----------------------	----------------------

### Dimensions

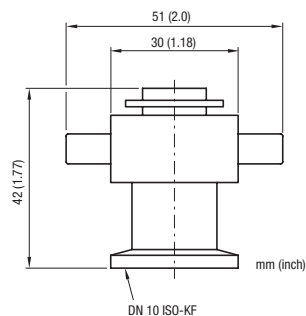

# Solenoid Actuated Venting Valve

## VVM010-A

### Advantages

- No vacuum feedthrough
- Long service life
- Mountable in any position



### Selection Data

Vacuum connection	DN 10 ISO-KF
-------------------	--------------

### Ordering Information

Type	Part No.	VVM010-A
230 V AC, 50/60 Hz	Part No.	<b>250-533</b>
115 V AC, 50/60 Hz	Part No.	<b>250-532</b>
24 V AC, 50/60 Hz	Part No.	<b>250-531</b>
24 V DC	Part No.	<b>250-530</b>

### Specifications

Service life	cycles	1 500 000
Tightness	mbar l/s	$1 \times 10^{-9}$
Conductance for molecular flow	l/s	1
Conductance at 1mbar	l/s	3.5
Pressure absolute min./max.	mbar/bar	$1 \times 10^{-8}$
Duty cycle	%	100
Differential pressure in closing / opening direction	bar	10 / 1
opens to a pressure difference of	bar	2
Ambient temperature	°C	5 – 40
Pickup / holding power	VA	35 / 15
Pressure resistance	bar	10
Closing / opening time	ms	60 / 45
Switching frequency	1/min	50
Housing		aluminum
Seals		FPM
Weight	kg	0.46

## VVM010-A - continued

### Options

Filter with port, centering ring and clamping ring

215-152

### Spare Parts

Seal set  
Filter

215-208  
B 4161 210 4F

### Dimensions

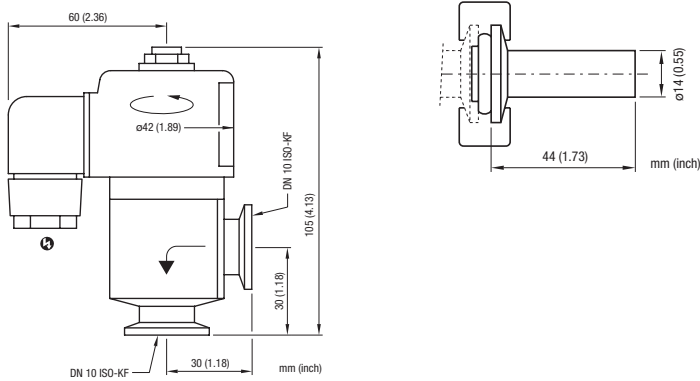



# Power Failure Venting Valve

## VIM010-A

### Advantages

- For automatic venting of pumps, system or vacuum chambers in case of a power failure



### Selection Data

Vacuum connection	DN 10 ISO-KF
Venting time for a 50 l vessel	270 s

### Ordering Information

<b>Type</b>	<b>VIM010-A</b>
200 - 230 V, 50/60 Hz	<b>250-851</b>
24 V DC	<b>250-850</b>
115 V, 50/60 Hz	<b>250-852</b>

### Specifications

Part number		250-850	250-851	250-852
Tightness	mbar l/s		$1 \times 10^{-7}$	
Ambient temperature	°C		0 – 50	
Switching frequency	1/min		60	
Service life	Mio cycles		3	
Opening time	ms		30	
Closing time	ms		30	
Housing		aluminum		
Seal		FPM		
Nominal power				
Pickup	W / VA	2.5 / –	– / 5	– / 5
Holding	W / VA	2.5 / –	– / 3.7	– / 3.7
Protection class		IP 65		
Weight	kg	0.1		

### Dimensions

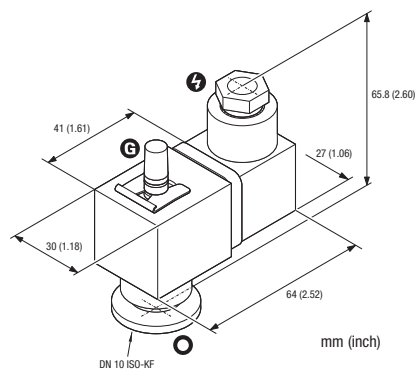

# Vacuum Safety Valves

## VSM DN 16 – DN 100

### Advantages

- Fast-closing high vacuum isolation valve for separating the vacuum chamber from the backing pump
- Venting valve for roughing pumps
- Immediate closing action upon power failure
- Opening action only after the intake line has been evacuated



### Selection Data

Vacuum connection	DN 16 ISO-KF	DN 25 ISO-KF	DN 40 ISO-KF	DN 63 ISO-K	DN 100 ISO-K
-------------------	--------------	--------------	--------------	-------------	--------------

### Ordering Information

Type	VSM016-A	VSM025-A	VSM040-A	VSM063-A	VSM100-A
200 - 230 V AC	253-004	253-014	253-024	253-034	253-044
100 - 115 V AC	253-002	253-012	253-022	253-032	253-042
24 V DC	253-000	253-010	253-020	253-030	253-040

### Specifications

Nominal power	DC AC	2.5 W 5 / 3.7 VA (starting / holding)			
Type of protection	IP 65 according to DIN 40 050				
Conductance	3.8 l/s	11 l/s	30.5 l/s	126 l/s	300 l/s
Installation position	any				
Tightness	body valve plate	< 1x10 <sup>-9</sup> mbar l/s < 1x10 <sup>-5</sup> mbar l/s			
Pressure range	1x10 <sup>-8</sup> mbar – 1 bar (abs.)				
Required pressure difference up for the safety valves to function properly	in closing direction		> 150 mbar		
	in opening direction		< 150 mbar		
Temperatures	ambiance 5°C – 50°C				
Solenoid coil	ambiance 20°C		< 55°C		
	ambiance 20°C		< 80°C		
Bakeout	housing		< 60°C		
	actuator		< 50°C		
Materials	housing, flange seals		aluminum FPM		
Weight	0.3 kg	0.5 kg	0.9 kg	2.4 kg	5.1 kg

## VSM DN 16 – DN 100 – continued

### Spare Parts

Seal set	215-055	215-056	215-057	215-058	215-059
----------	---------	---------	---------	---------	---------

### Dimensions

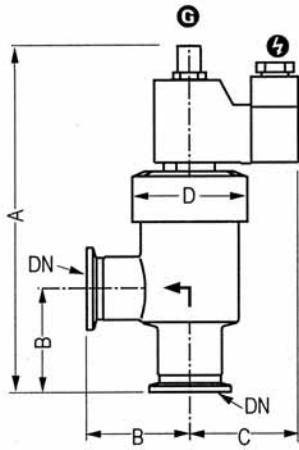

DN	A	B	C	D
DN 16 ISO-KF	139	40	49	44
DN 25 ISO-KF	162	50	49	56
DN 40 ISO-KF	178	65	49	82

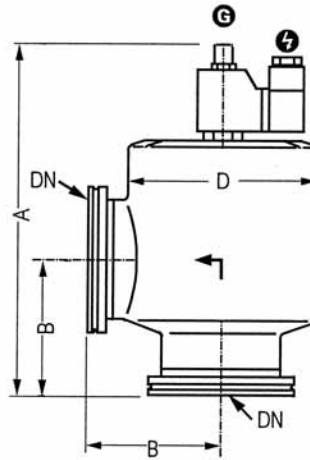

DN	A	B	D
DN 63 ISO-K	220	88	124
DN 100 ISO-K	264	108	164

# Pressure Relief Valve

## VSA016-X

### Advantages

- Protects vacuum systems from pressure >1.5bar
- Relief trigger point 1.2 to 1.5 bar absolute



### Selection Data

Vacuum connection	DN 16 ISO-KF
-------------------	--------------

### Ordering Information

Type	VSA016-X
Part No.	250-555

### Specifications

Tightness	mbar l/s	$1 \times 10^{-9}$
Pressure absolute min./max.	mbar / bar	$1 \times 10^{-3}$ / 1.2 (absolute)
Gas flow	l/min	0 – 6
Ambient temperature	°C	0 – 50
Bakeout temperature	°C	150
Housing		stainless steel
Seal		FPM
Weight	kg	0.1

### Dimensions

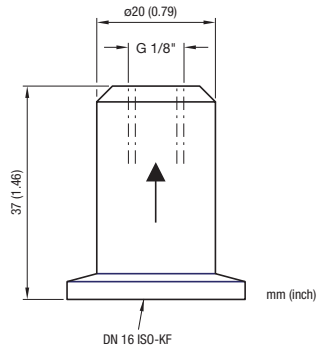

# Ball Valves with ISO-KF Flanges

## DN 10-40

### Advantages

- Rugged and cost effective
- Simple opening and closing by lever
- Unobstructed passage



### Selection Data

Vacuum connection	DN 10 ISO-KF	DN 16 ISO-KF	DN 25 ISO-KF	DN 40 ISO-KF
-------------------	--------------	--------------	--------------	--------------

### Ordering Information

Part No.	215-860	215-861	215-862	215-863
----------	---------	---------	---------	---------

### Specifications

Tightness	mbar/ls	$1 \times 10^{-5}$	$1 \times 10^{-5}$	$1 \times 10^{-5}$	$1 \times 10^{-5}$
Conductance for molecular flow	l/s	1.5	3	9	30
Pressure absolute min./max.	mbar/bar	$10^{-5} / 5^{1)}$	$10^{-5} / 5^{1)}$	$10^{-5} / 5^{1)}$	$10^{-5} / 5^{1)}$
Bakeout temperature	°C	80	80	80	80
Housing		brass nickel plated	brass nickel plated	brass nickel plated	brass nickel plated
Seals		PTFE	PTFE	PTFE	PTFE
Weight	kg	0.35	0.35	0.35	0.35

1) With outer centering ring

### Dimensions

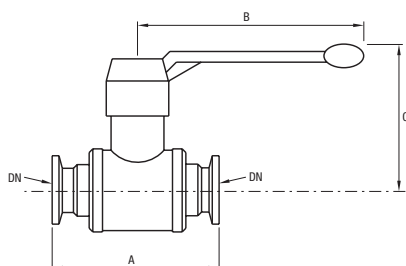

DN	A	B	C
DN 10 ISO-KF	75	83	47
DN 16 ISO-KF	100	95	51
DN 25 ISO-KF	130	110	64
DN 40 ISO-KF	160	160	85

---

# **Vacuum Fittings**

**Fittings and Ultra-High Components**

---

## VACUUM FITTINGS

### ISO-KF Small Flange Components

CONNECTION ELEMENTS .....	D1
SEALS.....	D3
FLANGES .....	D6
PIPE FITTINGS .....	D7
BELLOWS/HOSE WITH FLANGES .....	D9
TRANSITION PIECES.....	D11
HOSE, HOSE CONNECTION.....	D14

### ISO-K Clamp Flange Components

CONNECTION ELEMENTS .....	D16
SEALS.....	D17
FLANGES .....	D20
PIPE FITTINGS .....	D22
BELLOWS / HOSE WITH FLANGES .....	D24
TRANSITION PIECES.....	D25
PROTECTIVE LIDS.....	D26

### ISO-F Fixed Flange Components

FLANGE COMPONENTS .....	D27
-------------------------	-----

### UHV CF Components

CONNECTION ELEMENTS .....	D29
SEALS.....	D30
FLANGES .....	D32
PIPE FITTINGS .....	D36
BELLOWS / HOSE WITH FLANGES, COMPENSATOR.....	D38
TRANSITION PIECES.....	D39
PROTECTIVE LIDS.....	D40

### Website

# ISO-KF Small Flange Components

## CONNECTION ELEMENTS

### Clamping Ring Wing Nut

		DN ... ISO-KF	Part No.	A	B	C
Clamping ring half:	aluminum 380.0/3.2162	10 – 16	<b>211-001</b>	45	61	16
Bolt:	steel nickel plated	20 – 25	<b>211-002</b>	55	72	16
Nut:	zinc alloy nickel plated	32 – 40	<b>211-003</b>	70	90	18
		50	<b>211-004</b>	95	123	25

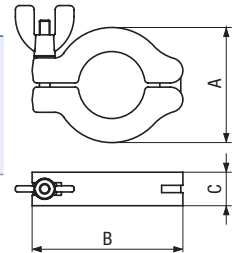

### Clamping Ring Hex Nut

		DN ... ISO-KF	Part No.	A	B	C
Clamping ring half:	aluminum 380.0/3.2162	10 – 16	<b>211-611</b>	45	61	16
Bolt & nut:	steel nickel plated	20 – 25	<b>211-612</b>	55	72	16
		32 – 40	<b>211-613</b>	70	90	18
		50	<b>211-614</b>	95	123	25

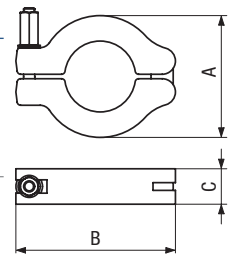

### Rapid Fastening Clamp

		DN ... ISO-KF	Part No.	A	B	C
Spring:	steel	10 – 16	<b>211-005</b>	52	70	16
Clamping ring half:	aluminum 380.0/3.2162	20 – 25	<b>211-006</b>	61	81	16
Lever:	polyamide	32 – 40	<b>211-007</b>	75	98	18

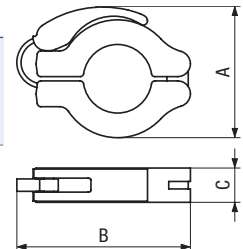

### Rapid Fastening Clamp All Metal

		DN ... ISO-KF	Part No.	A	B	C
Spring:	stainless steel	10 – 16	<b>211-036</b>	52	71	16
Clamping ring half:	aluminum 380.0/3.2162	20 – 25	<b>211-037</b>	61	72	16
Lever:	aluminum -/3.2982	32 – 40	<b>211-038</b>	78	99	18

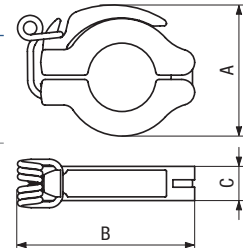

### Chain Clamp

		DN ... ISO-KF	Part No.	A	B	C
Chain link:	aluminum 6081/3.2215	10 – 16	<b>211-021</b>	71	52.5	18
Screw & nut & bolts:	stainless steel	20 – 25	<b>211-022</b>	82	65	18
		32 – 40	<b>211-023</b>	98	79	18
		50	<b>211-024</b>	117	97.5	20

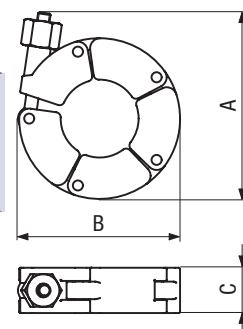



## CONNECTION ELEMENTS - continued

<b>Clamping Element</b>		DN ... ISO-KF	Part No.	A	B	C
Clamping Element:	aluminum 380.0/3.2162	10 – 16	<b>211-008</b>	52		18
Bolt:	stainless steel	20 – 25	<b>211-009</b>	55	72	16
Nut:	steel zinc plated	32 – 40	<b>211-010</b>	70	90	18
		50	<b>211-011</b>	95	123	25

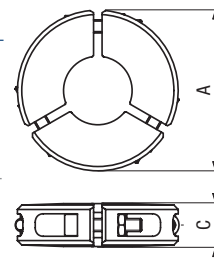

<b>Hose Clip Clamping Ring</b>		DN ... ISO-KF	Part No.	A	B	C
Clamping ring half:	aluminum 380.0/3.2162	10 – 16	<b>211-016</b>	42	54	16
Band:	stainless steel 430/1.4016	20 – 25	<b>211-017</b>	52	64	16
Bolt & nut thread:	steel zinc plated	32 – 40	<b>211-018</b>	67	79	16

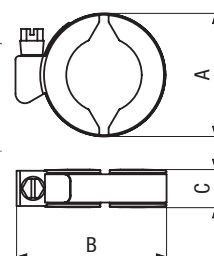

<b>Claw Grip</b>		DN ... ISO-KF	Part No.	A	B	C	D	E	Set of
Claw:	aluminum 6081/3.2215	10 – 50	<b>211-015</b>	19.5	11.5	12.5	20	14	4 pcs.
Screw & washer:	stainless steel								

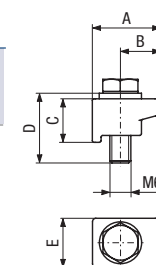

# ISO-KF Small Flange Components

## SEALS

<b>Centering Ring</b>		DN ... ISO-KF	Part No.	A	B	C	D
Ring: Aluminum 6082/- Seal: Elastomer CR	10	<b>211-051</b>	12	10	8	3.9	
	16	<b>211-052</b>	17	16	8	3.9	
	20	<b>211-053</b>	22	20	8	3.9	
	25	<b>211-054</b>	26	25	8	3.9	
	32	<b>211-055</b>	34	32	8	3.9	
	40	<b>211-056</b>	41	40	8	3.9	
	50	<b>211-057</b>	52	50	8	3.9	
Ring: Aluminum 6082/- Seal: Elastomer FPM	10	<b>211-058</b>	12	10	8	3.9	
	16	<b>211-059</b>	17	16	8	3.9	
	20	<b>211-060</b>	22	20	8	3.9	
	25	<b>211-061</b>	26	25	8	3.9	
	32	<b>211-062</b>	34	32	8	3.9	
	40	<b>211-063</b>	41	40	8	3.9	
	50	<b>211-064</b>	52	50	8	3.9	
Ring: Stainless steel 303/1.4305- Seal: Elastomer FPM	10	<b>211-065</b>	12	10	8	3.9	
	16	<b>211-066</b>	17	16	8	3.9	
	20	<b>211-067</b>	22	20	8	3.9	
	25	<b>211-068</b>	26	25	8	3.9	
	32	<b>211-069</b>	34	32	8	3.9	
	40	<b>211-070</b>	41	40	8	3.9	
	50	<b>211-071</b>	52	50	8	3.9	

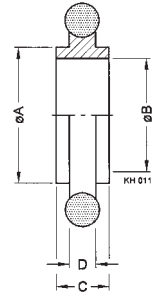

<b>External Centering Ring</b>		DN ... ISO-KF	Part No.	A	B	C	D
Ring: Aluminum 6082/- Seal: Elastomer CR	10-16	<b>211-081</b>	32	30.2	7	3.9	
	20-25	<b>211-082</b>	42	40.2	7	3.9	
	32-40	<b>211-083</b>	57	55.2	7	3.9	
	50	<b>211-084</b>	77	75.2	7	3.9	
Ring: Aluminum 6082/- Seal: Elastomer FPM	10-16	<b>211-085</b>	32	30.2	7	3.9	
	20-25	<b>211-086</b>	42	40.2	7	3.9	
	32-40	<b>211-087</b>	57	55.2	7	3.9	
	50	<b>211-088</b>	77	75.2	7	3.9	

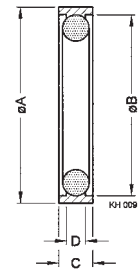

<b>Reducing Centering Ring</b>		DN ... ISO-KF	Part No.	A	B	C	D	E
Ring: Aluminum 6082/- Seal: Elastomer CR	10 / 16	<b>211-072</b>	17	10	12	8	3.9	
	20 / 25	<b>211-073</b>	26	20	22	8	3.9	
	32 / 40	<b>211-074</b>	41	32	34	8	3.9	
Ring: Aluminum 6082/- Seal: Elastomer FPM	10 / 16	<b>211-075</b>	17	10	12	8	3.9	
	20 / 25	<b>211-076</b>	26	20	22	8	3.9	
	32 / 40	<b>211-077</b>	41	32	34	8	3.9	
Ring: Stainless steel 303/1.4305 Seal: Elastomer FPM	10 / 16	<b>211-078</b>	17	10	12	8	3.9	
	20 / 25	<b>211-079</b>	26	20	22	8	3.9	
	32 / 40	<b>211-080</b>	41	32	34	8	3.9	

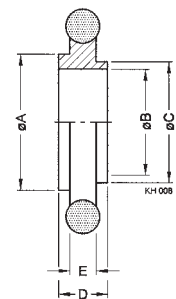

## SEALS - continued

### Centering Ring with Filter

	DN ... ISO-KF	Part No.	A	B	C	D	E*
Ring: Stainless steel 303/1.4305	10	<b>211-089</b>	12	8	8	3.9	0.5m <sup>3</sup> /h
Seal: Elastomer FPM	16	<b>211-090</b>	17	14	8	3.9	1.2m <sup>3</sup> /h
Filter: Stainless steel 316L/1.4435	25	<b>211-092</b>	26	23	8	3.9	4.2m <sup>3</sup> /h
Pore size 0.02 mm	40	<b>211-094</b>	41	38	8	3.9	11.3m <sup>3</sup> /h
* Air at 0°C, 20 mbar differential pressure	50	<b>211-095</b>	52	48	8	3.9	18.1m <sup>3</sup> /h

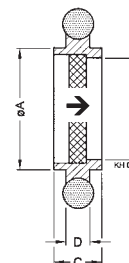

→ Recommended gas flow direction

### Centering Ring with Fine Filter

	DN ... ISO-KF	Part No.	A	B	C	D
Inner ring: Stainless steel 303/1.4305	10	<b>211-096</b>	12	9	8	3.9
Snab ring: Stainless steel 304/1.4301	16	<b>211-097</b>	17	13	8	3.9
Seal: Elastomer FPM	25	<b>211-098</b>	26	22	8	3.9
Filter: Stainless steel 316L/1.4435	40	<b>211-099</b>	41	35.5	8	3.9
Pore size 0.004 mm	50	<b>211-100</b>	52	45.7	8	3.9
Degree of separation at 0.001 mm up to 98%						

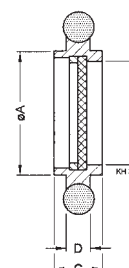

### O-Ring

	DN ... ISO-KF	Part No.	A	B	Set of
Elastomer CR	10	<b>211-146</b>	15	5	10 pcs.
	16	<b>211-147</b>	18	5	10 pcs.
	20	<b>211-148</b>	25	5	10 pcs.
	25	<b>211-149</b>	28	5	10 pcs.
	32	<b>211-150</b>	40	5	10 pcs.
	40	<b>211-151</b>	42	5	10 pcs.
	50	<b>211-152</b>	55	5	10 pcs.
Elastomer FPM	10	<b>211-153</b>	15	5	10 pcs.
	16	<b>211-154</b>	18	5	10 pcs.
	20	<b>211-155</b>	25	5	10 pcs.
	25	<b>211-156</b>	28	5	10 pcs.
	32	<b>211-157</b>	40	5	10 pcs.
	40	<b>211-158</b>	42	5	10 pcs.
	50	<b>211-159</b>	55	5	10 pcs.

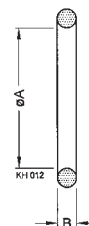

### Indium Seal

	DN ... ISO-KF	Part No.	A	B	C	D	E
Inner ring: Stainless steel 304/1.4301	10-16	<b>211-162</b>	32	18	30	3.9	7
Outer ring: Aluminum 5012/-	20-25	<b>211-163</b>	42	28	40	3.9	7
Seal: Indium	32-40	<b>211-164</b>	57	43	55	3.9	7
Working temperature: -196° to +60°C	50	<b>211-165</b>	77	63	75	3.9	7

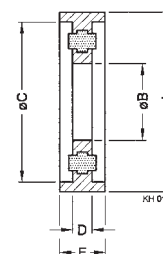

**SEALS** - continued

**Aluminum Seal**

	DN ... ISO-KF	Part No.	A	B	C	D	With Support Ring
Aluminum anneated 6082/3.2315	10-16	<b>211-167</b>	25.6	19.6	4.5	22.6	211-171
	20-25	<b>211-168</b>	35.6	29.6	4.5	32.6	211-168
	32-40	<b>211-169</b>	50.6	44.6	4.5	47.6	211-173
Set of 3 pieces	50	<b>211-170</b>	65.6	59.6	4.5	62.6	211-174

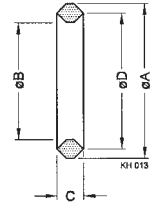

**Support for Aluminum Seal**

	DN ... ISO-KF	Part No.	A	B	For Aluminum Seal
Stainless steel 301/1.4310	10-16	<b>211-171</b>	32	7	211-167
	20-25	<b>211-172</b>	42	7	211-168
	32-40	<b>211-173</b>	57	7	211-169
Reusable	50	<b>211-174</b>	77	7	211-170

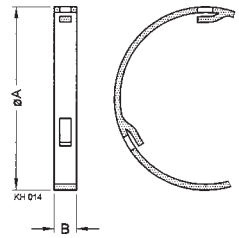

# ISO-KF Small Flange Components

## FLANGES

<b>Blank Flange</b>	DN ... ISO-KF	Part No.	A
Aluminum 6082/-	10	<b>211-176</b>	5
	16	<b>211-177</b>	5
	25	<b>211-178</b>	5
	40	<b>211-179</b>	5
	50	<b>211-180</b>	6
Stainless steel 304/1.4301	10	<b>211-181</b>	5
	16	<b>211-182</b>	5
	25	<b>211-183</b>	5
	40	<b>211-184</b>	5
	50	<b>211-185</b>	6

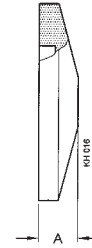

<b>Flange with Tube, Short</b>	DN ... ISO-KF	Part No.	A	B	C
Steel -/1.0037	10	<b>211-201</b>	20	12	16
	16	<b>211-202</b>	20	16	20
	25	<b>211-203</b>	20	26	30
	40	<b>211-204</b>	20	41	45
	50	<b>211-205</b>	20	51	55
Stainless steel 304/1.4301	10	<b>211-211</b>	20	12	16
	16	<b>211-212</b>	20	16	20
	25	<b>211-213</b>	20	26	30
	40	<b>211-214</b>	20	41	45
	50	<b>211-215</b>	20	50	54

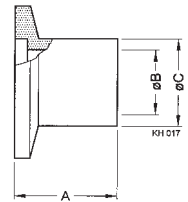

<b>Flange with Tube, Long</b>	DN ... ISO-KF	Part No.	A	B	C
Steel -/1.0037	10	<b>211-206</b>	70	12	16
	16	<b>211-207</b>	70	16	20
	25	<b>211-208</b>	70	26	30
	40	<b>211-209</b>	70	41	45
	50	<b>211-210</b>	70	51	55
Stainless steel 304/1.4301	10	<b>211-216</b>	70	12	16
	16	<b>211-217</b>	70	16	20
	25	<b>211-218</b>	70	26	30
	40	<b>211-219</b>	70	41	45
	50	<b>211-220</b>	70	50	54

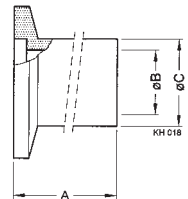

# ISO-KF Small Flange Components

## PIPE FITTINGS

### Elbow 90°

	DN ... ISO-KF	Part No.	A	B
Aluminum 6082/-	10	<b>211-251</b>	30	12
	16	<b>211-252</b>	40	16
	25	<b>211-253</b>	50	25
	40	<b>211-254</b>	65	39
Stainless steel 304/1.4301	10	<b>211-286</b>	30	9
	16	<b>211-287</b>	40	15
	25	<b>211-288</b>	50	25
	40	<b>211-289</b>	65	40.5
	50	<b>211-290</b>	70	49

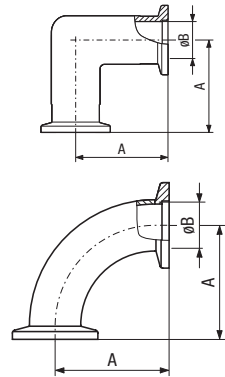

### Elbow 45°

	DN ... ISO-KF	Part No.	A	B	C
Stainless steel 304/1.4301	16	<b>211-307</b>	26	55	15
	25	<b>211-308</b>	32	68.8	25
	40	<b>211-309</b>	40	87.7	37

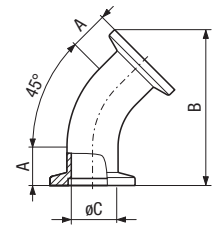

### Tee

	DN ... ISO-KF	Part No.	A	B	C
Aluminum 6082/-	10	<b>211-261</b>	30	60	12
	16	<b>211-262</b>	40	80	16
	25	<b>211-263</b>	50	100	25
	40	<b>211-264</b>	65	130	39
Stainless steel 304/1.4301	10	<b>211-291</b>	30	60	12
	16	<b>211-292</b>	40	80	16
	25	<b>211-293</b>	50	100	25
	40	<b>211-294</b>	65	130	40.5
	50	<b>211-295</b>	70	140	53

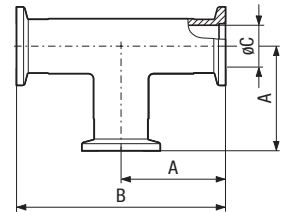

### Reducing Tee

	DN ... ISO-KF	Part No.	A	B	C
Stainless steel 304/1.4301	25/16	<b>211-316</b>	50	100	40
	40/16	<b>211-317</b>	65	130	40
	40/25	<b>211-318</b>	65	130	50
	50/16	<b>211-319</b>	70	140	50
	50/25	<b>211-320</b>	70	140	65
	50/40	<b>211-321</b>	70	140	65

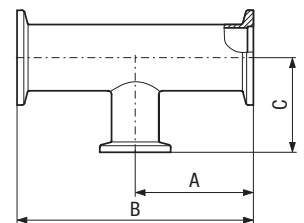

## PIPE FITTINGS - continued

<b>Cross</b>	DN ... ISO-KF	Part No.	A	B	C
Aluminum 6082/3.2315	10	<b>211-266</b>	30	60	12
	16	<b>211-267</b>	40	80	16
	25	<b>211-268</b>	50	100	25
	40	<b>211-269</b>	65	130	39
Stainless steel 304/1.4301	10	<b>211-296</b>	30	60	12
	16	<b>211-297</b>	40	80	16
	25	<b>211-298</b>	50	100	25
	40	<b>211-299</b>	65	130	40.5
	50	<b>211-300</b>	70	140	53

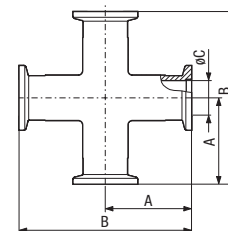

<b>Reducing Cross</b>	DN ... ISO-KF	Part No.	A	B	C	D	E	F
Aluminum 6082/3.2315	25/16	<b>211-271</b>	35	70	35	70	25	16
	40/16	<b>211-272</b>	40	80	45	90	39	16
Stainless steel 304/1.4301	25/16	<b>211-301</b>	35	70	35	70	25	17
	40/16	<b>211-302</b>	40	80	45	90	40.5	16
	50/16	<b>211-303</b>	50	100	50	100	53	16

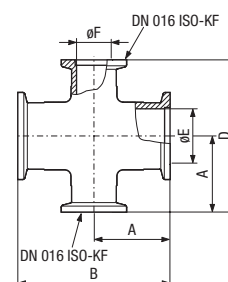

<b>Intermediate Piece</b>	DN ... ISO-KF	Part No.	A	B
Aluminum 6082/-	16	<b>211-227</b>	80	16
	25	<b>211-228</b>	100	25
	40	<b>211-229</b>	130	40
Stainless steel 304/1.4301	16	<b>211-277</b>	80	16
	25	<b>211-278</b>	100	25
	40	<b>211-279</b>	130	40.5
	50	<b>211-280</b>	140	53

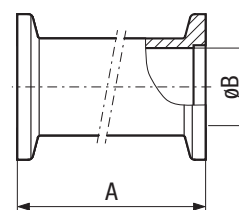

<b>Reducer</b>	DN ... ISO-KF	Part No.	A	B
Aluminum 6082/-	25/16	<b>211-231</b>	40	16
	40/16	<b>211-232</b>	40	16
	40/25	<b>211-233</b>	40	25
	50/40	<b>211-234</b>	40	40
Stainless steel 303/1.4305	25/16	<b>211-281</b>	40	16
	40/16	<b>211-282</b>	40	16
	40/25	<b>211-283</b>	40	26
	50/16	<b>211-323</b>	40	16
	50/25	<b>211-324</b>	40	26
	50/40	<b>211-284</b>	40	40

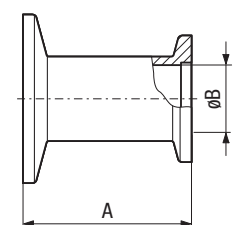

# ISO-KF Small Flange Components

## BELLOWS/HOSE WITH FLANGES

### Bellows

	DN ... ISO-KF	Part No.	A	B	C	D	E
Flanges: stainless steel 304/1.4301	10	<b>211-326</b>	70	3.5	3	23°	5
Bellow: stainless steel 316Ti/-	16	<b>211-327</b>	70	6.4	4.1	21°	4
	25	<b>211-328</b>	80	8	5	17°	3.5
Max. internal pressure: 4bar	40	<b>211-329</b>	100	11	7	15°	7
A = unstressed length	50	<b>211-330</b>	100	10	6	15°	8
D = max. deviation from axis							
E = lateral displacement							

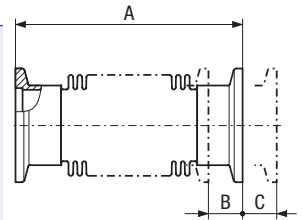

### Metal Hose

	DN ... ISO-KF	Part No.	A	B	C
Flanges: stainless steel 304/1.4301	10	<b>211-331</b>	250	70	32
Bellow: stainless steel 316Ti/-	10	<b>211-332</b>	500	70	32
	10	<b>211-333</b>	750	70	32
	10	<b>211-334</b>	1000	70	32
	16	<b>211-335</b>	250	70	50
	16	<b>211-336</b>	500	70	50
	16	<b>211-337</b>	750	70	50
	16	<b>211-338</b>	1000	70	50
	16	<b>211-531</b>	1500	70	50
	16	<b>211-532</b>	2000	70	50
	25	<b>211-339</b>	250	100	60
	25	<b>211-340</b>	500	100	60
	25	<b>211-341</b>	750	100	60
	25	<b>211-342</b>	1000	100	60
	25	<b>211-533</b>	1500	100	103
	25	<b>211-534</b>	2000	100	103
	40	<b>211-343</b>	250	130	100
	40	<b>211-344</b>	500	130	100
	40	<b>211-345</b>	750	130	100
	40	<b>211-346</b>	1000	130	100
	40	<b>211-535</b>	1500	130	129
	40	<b>211-536</b>	2000	130	129
	50	<b>211-347</b>	250	200	130
Max. internal pressure: 4 bar	50	<b>211-348</b>	500	200	130
B = radius for multiple bending	50	<b>211-349</b>	750	200	130
C = radius for single bend	50	<b>211-350</b>	1000	200	130

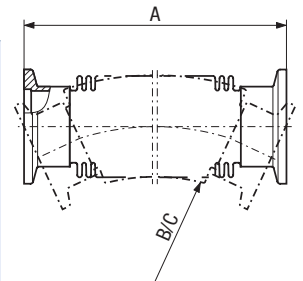



## BELLOWS/HOSE WITH FLANGES - continued

<b>Metal Hose, Flexible</b>	DN ... ISO-KF	Part No.	A	B	C
Flanges: stainless steel 304/1.4301	16	<b>211-515</b>	250	40	25
Bellow: stainless steel 316Ti/-	16	<b>211-516</b>	500	40	25
	16	<b>211-517</b>	750	40	25
	16	<b>211-518</b>	1000	40	25
	25	<b>211-519</b>	250	55	36
	25	<b>211-520</b>	500	55	36
	25	<b>211-521</b>	750	55	36
	25	<b>211-522</b>	1000	55	36
	40	<b>211-523</b>	250	90	60
	40	<b>211-524</b>	500	90	60
	40	<b>211-525</b>	750	90	60
Max. internal pressure: 2 bar	40	<b>211-526</b>	1000	90	60
B = radius for multiple bending	50	<b>211-527</b>	250	100	65
C = radius for single bend	50	<b>211-528</b>	500	100	65

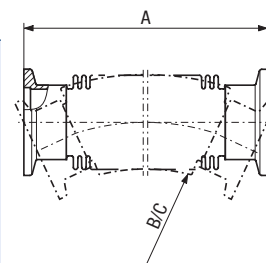

<b>PVC Hose</b>	DN ... ISO-KF	Part No.	A	B	C
Hose: PVC with cast in steel spiral	16	<b>211-406</b>	500	130	65
Nipple: aluminum 6082/-	16	<b>211-407</b>	1000	130	65
Hose clamp: stainless steel 430/-	25	<b>211-408</b>	500	200	100
	25	<b>211-409</b>	1000	200	100
	25	<b>211-412</b>	2000	200	100
B = radius for multiple bending	40	<b>211-410</b>	500	260	130
C = radius for single bend	40	<b>211-411</b>	1000	260	130

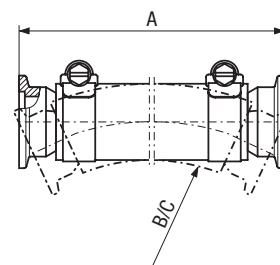

# ISO-KF Small Flange Components

## TRANSITION PIECES

### Adapter ISO-KF/ISO-K

	ISO-KF/ISO-K	Part No.	A
Aluminum 6082/-	40/63	<b>212-171</b>	40
	50/63	<b>212-172</b>	45
Stainless steel 303/1.4305	40/63	<b>212-173</b>	40
	50/63	<b>212-174</b>	45
	40/100	<b>212-175</b>	40

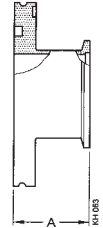

### Adapter ISO-KF/CF-F

	ISO-KF/CF-F	Part No.	A	B
Stainless steel 304/1.4301	16/16	<b>213-251</b>	35	16
	25/16	<b>213-252</b>	35	16
	16/40	<b>213-254</b>	30	16
	25/40	<b>213-255</b>	30	26
	40/40	<b>213-256</b>	50	37
	40/63	<b>213-259</b>	35	41
	40/100	<b>213-262</b>	50	41

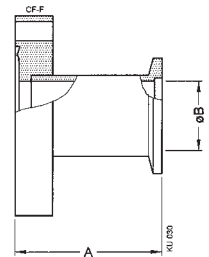

### Adapter ISO-KF/VCR Female

	ISO-KF/VCR	Part No.	A
Flange: Stainless steel 304/1.4301	16/ 1/4"	<b>211-359</b>	35.8
Nut: Stainless steel 316L/1.4435	25/ 1/4"	<b>211-480</b>	35.8
	25/ 1/2"	<b>211-360</b>	40.6
Width across flats in inch	40/ 3/4"	<b>211-361</b>	53.3

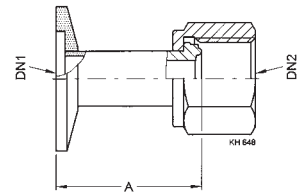

### Adapter ISO-KF/VCR Male

	ISO-KF/VCR	Part No.	A
Flange: Stainless steel 304/1.4301	16/ 1/4"	<b>211-362</b>	35.8
Nut: Stainless steel 316L/1.4435	25/ 1/4"	<b>211-481</b>	35.8
	25/ 1/2"	<b>211-363</b>	40.6
Width across flats in inch	40/ 3/4"	<b>211-364</b>	53.3

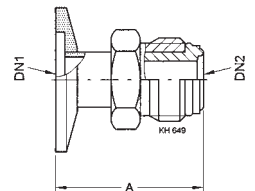

## TRANSITION PIECES - continued

### Adapter ISO-KF/Swagelok

	ISO-KF/Swagelok	Part No.	A	B
Flange: Stainless steel 304/1.4301	16/6 mm	<b>211-356</b> <sup>1)</sup>	37	15.3
Nut: Stainless steel 316L/1.4435	25/10 mm	<b>211-357</b> <sup>1)</sup>	45	17.2
	40/16 mm	<b>211-358</b> <sup>1)</sup>	53	24.4
	16/ 1/8"	<b>211-476</b> <sup>2)</sup>	34.5	12.7
	25/ 1/4"	<b>211-477</b> <sup>2)</sup>	37	15.3
	40/ 1/4"	<b>211-478</b> <sup>2)</sup>	37	15.3
	40/ 1/2"	<b>211-479</b> <sup>2)</sup>	47.5	22.8

<sup>1)</sup> Width across flats metric (SI)

<sup>2)</sup> Width across flats in inch

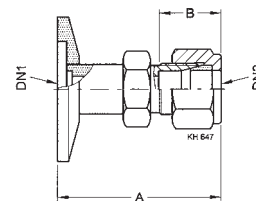

### Glass Tube Connection

	DN ... ISO-KF	Part No.	A	B	C	D
Flange: Aluminum 6082/-	10	<b>211-351</b>	50	8	10	30
Sealing: Elastomer FPM	40	<b>211-353</b>	65	22	26	45
Tube: Glas Pyrex						

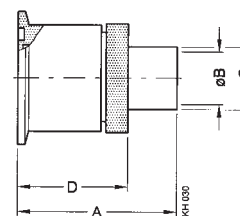

### Screw-in Flange

	ISO-KF/DN	Part No.	A	B	C	D
Flange: Stainless steel 303/1.4305	10/ G 3/8"	<b>211-366</b>	35	15	G 3/8"	12
Sealing: Elastomer FPM	16/ G 1/2"	<b>211-367</b>	35	15	G 1/2"	16
	25/ G 1"	<b>211-368</b>	45	25	G 1"	25
Width across flats metric (SI)	40/ G 1 1/2"	<b>211-369</b>	50	30	G 1 1/2"	41

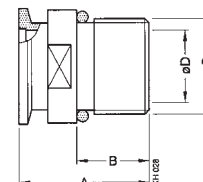

### Screw-on Flange

	ISO-KF/DN	Part No.	A	B	C	D
Flange: Stainless steel 303/1.4305	10/ G 3/8"	<b>211-376</b>	35	15	G 3/8"	10
Sealing: Elastomer FPM	16/ G 1/2"	<b>211-377</b>	35	15	G 1/2"	15
	25/ G 1"	<b>211-378</b>	45	25	G 1"	24
Width across flats metric (SI)	40/ G 1 1/2"	<b>211-379</b>	50	30	G 1 1/2"	38

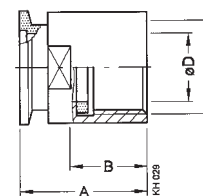

## TRANSITION PIECES - continued

### Adapter ISO-KF/NPT Female

	ISO-KF/NPT	Part No.	A	B	C	D
Stainless steel 303	16/ 1/8"	<b>211-566</b>	19	10	12	1/8-27 NPT
	16/ 1/4"	<b>211-567</b>	19	13	15	1/4-18 NPT
	25/ 1/8"	<b>211-569</b>	19	10	12	1/8-27 NPT
	25/ 1/4"	<b>211-570</b>	19	13	15	1/4-18 NPT
	25 / 1/2"	<b>211-571</b>	26	18	25	1/2-14 NPT
	25 / 1"	<b>211-572</b>	42	24	25	1-11 1/2 NPT
	40 / 1/4"	<b>211-574</b>	19	13	15	1/4-18 NPT
	40 / 1/2"	<b>211-575</b>	26	18	25	1/2-14 NPT
Width across flats in inch	40 / 1"	<b>211-576</b>	26	23	41	1-11 1/2 NPT

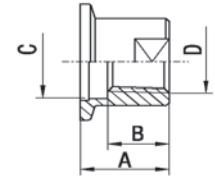

### Adapter ISO-KF/NPT Male

	ISO-KF/NPT	Part No.	A	B	C	D
Stainless steel 303 / 1.4305	16/ 1/8"	<b>211-551</b>	40	17	5	1/8-27 NPT
	16/ 1/4"	<b>211-552</b>	40	22	7	1/4-18 NPT
	25/ 1/8"	<b>211-554</b>	40	17	5	1/8-27 NPT
	25/ 1/4"	<b>211-555</b>	40	22	7	1/4-18 NPT
	25 / 1/2"	<b>211-556</b>	50	30	14	1/2-14 NPT
	25 / 1"	<b>211-557</b>	60	32	25	1-11 1/2 NPT
	40 / 1/4"	<b>211-559</b>	40	21	7	1/4-18 NPT
	40 / 1/2"	<b>211-560</b>	50	30	14	1/2-14 NPT
	40 / 1"	<b>211-561</b>	60	33	25	1-11 1/2 NPT
	40 / 1 1/4"	<b>211-562</b>	50	31.5	32	1 1/4-11 1/2 NPT
	40 / 1 1/2"	<b>211-563</b>	50	28	32	1 1/2-11 1/2 NPT
	Width across flats in inch	40 / 2"	<b>211-564</b>	50	27	40

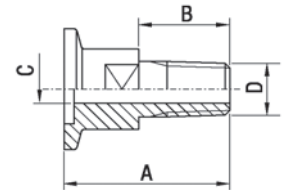

# ISO-KF Small Flange Components

## HOSE, HOSE CONNECTION

Hose Adapter 90°	DN ... ISO-KF	Part No.	A	B	C	D
Aluminum 6082/-	16	<b>211-257</b>	40	40	16	13
	25	<b>211-258</b>	50	50	25	22
	40	<b>211-259</b>	65	65	40	37

Hose Adapter for Rubber Hose	DN ... ISO-KF	Part No.	A	B	C
Aluminum 6082/-	16	<b>211-387</b>	40	7	12
	25	<b>211-388</b>	40	7	12
	40	<b>211-389</b>	40	7	12
Stainless steel 303/1.4305	16	<b>211-392</b>	40	7	12
	25	<b>211-393</b>	40	7	12
	40	<b>211-394</b>	40	7	12

Hose Connection	DN ... ISO-KF	Part No.	A	B	C
Aluminum 6082/-	25	<b>211-401</b>	40	13	16
	16	<b>211-402</b>	40	13	16
	25	<b>211-403</b>	40	22	25
	40	<b>211-404</b>	40	37	40

Sleeve with Hose Clamp	DN ... ISO-KF	Part No.	A	B	C	D	E
Hose clamp: Stainless steel 430/-	16	<b>211-417</b>	58	7	14	16	44
Sleeve: Elastomer CR	25	<b>211-418</b>	60	9	16	25	50
Max. internal pressure: 1 bar	40	<b>211-419</b>	64	13	20	40	68

Hose Clamp	DN ... ISO-KF	Part No.	A	B
Stainless steel 430/-	16	<b>211-461</b>	13	32
	25	<b>211-462</b>	19	44
	40	<b>211-463</b>	29	76

C = nominal connection for sleeve / hose

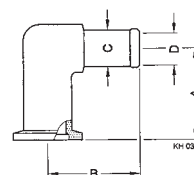

C = nominal connection for hose

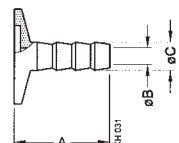

C = nominal connection for sleeve / hose

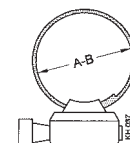
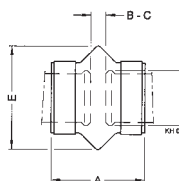
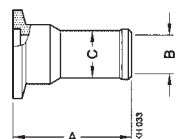

## HOSE, HOSE CONNECTION - continued

### PVC Hose

	DN ... ISO-KF	Part No.	A	B	C
With cast in spiral	16	<b>211-442</b>	23	16	130
	25	<b>211-443</b>	33	25	200
For vacuum applications Indicate length in meters	40	<b>211-444</b>	53	40	260

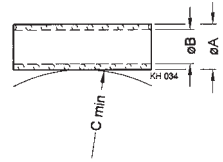

### Rubber Hose

	DN ... ISO-KF	Part No.	A	B
For vacuum applications	10	<b>211-451</b>	17	7
Indicate length in meters	16	<b>211-452</b>	25	10
Hardness: 55 ± 5 Shore A Temperature: -30 to +85 °C	20	<b>211-453</b>	32	16

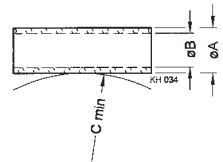

### Protective Lid

	DN ... ISO-KF	Part No.	A	B	C
Polyethylene	10-16	<b>211-427</b>	32	29	7.5
	20-25	<b>211-428</b>	42	39	7.5
	32-40	<b>211-429</b>	57	54	7.5
	50	<b>211-430</b>	77	74	7.5

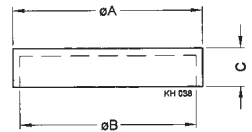

# ISO-K Clamp Flange Components

## CONNECTION ELEMENTS

<b>Clamp</b>	DN ... ISO-K	Part No.	A	B	C	Set of
Steel zinc plated 103/-	63-250	<b>212-225</b>	60	17	27	4 pcs.
	320-500	<b>212-226</b>	78	27	39	4 pcs.
	630	<b>212-227</b>	88	31	49	4 pcs.
Stainless steel 316/-	63-250	<b>212-228</b>	61	18	28	4 pcs.
	320-630	<b>212-240</b>	82	29	47	4 pcs.

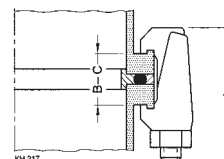

<b>Claw</b>	DN ... ISO-K	Part No.	A	B	C	Set of
Clamping flange / base plate	63-100	<b>212-231</b>	22.5	35	13.9	4 pcs.
	160-250	<b>212-232</b>	23	35	13.9	4 pcs.
	320-500	<b>212-233</b>	36.5	50	20.6	4 pcs.
	630	<b>212-234</b>	41.5	55	25.6	4 pcs.
Clamping flange/ base plate with groove	63-100	<b>212-235</b>	18.6	30	10	4 pcs.
	160-250	<b>212-236</b>	19	35	10	4 pcs.
	320-500	<b>212-237</b>	31	45	15	4 pcs.
	630	<b>212-233</b>	36.5	50	20.6	4 pcs.
Clamping flange with groove / base plate	63-100	<b>212-247</b>	20.6	30	12	4 pcs.
	160-250	<b>212-248</b>	21.1	35	12	4 pcs.
	320-500	<b>212-249</b>	33.9	45	18	4 pcs.
	630	<b>212-233</b>	36.5	50	20.6	4 pcs.

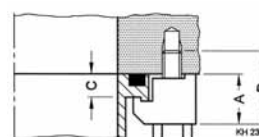
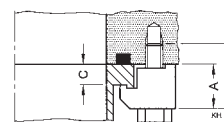
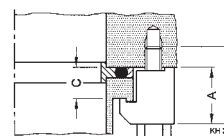

Steel zinc plated 103/-

# ISO-K Clamp Flange Components

## SEALS

<b>Centering Ring</b>		DN ... ISO-K	Part No.	A	B	C	D
Inner & outer ring:	Aluminum 6082/-	63	<b>212-251</b>	96	70	3.9	8
Seal:	Elastomer CR	80	<b>212-091</b>	109	83	3.9	8
		100	<b>212-252</b>	128	102	3.9	8
		160	<b>212-253</b>	179	153	3.9	8
		200	<b>212-254</b>	239	213	3.9	8
		250	<b>212-255</b>	287	261	3.9	8
		320	<b>212-256</b>	358	318	5.6	14
		400	<b>212-257</b>	440	400	5.6	14
		500	<b>212-258</b>	541	501	5.6	14
		630	<b>212-259</b>	691	651	5.6	14
Inner & outer ring:	Aluminum 6082/-	63	<b>212-261</b>	96	70	3.9	8
Seal:	Elastomer FPM	80	<b>212-092</b>	109	83	3.9	8
		100	<b>212-262</b>	128	102	3.9	8
		160	<b>212-263</b>	179	153	3.9	8
		200	<b>212-264</b>	239	213	3.9	8
		250	<b>212-265</b>	287	261	3.9	8
		320	<b>212-266</b>	358	318	5.6	14
		400	<b>212-267</b>	440	400	5.6	14
		500	<b>212-268</b>	541	501	5.6	14
		630	<b>212-269</b>	691	651	5.6	14
		800	<b>212-270</b>	840	800	5.6	14
		1000	<b>212-271</b>	1040	1000	5.6	14
Inner ring:	Stainless steel 304/-	63	<b>212-281</b>	96	70	3.9	8
Outer ring:	Aluminum 6082/-	80	<b>212-093</b>	109	83	3.9	8
Seal:	Elastomer FPM	100	<b>212-282</b>	128	102	3.9	8
		160	<b>212-283</b>	179	153	3.9	8
		200	<b>212-284</b>	239	213	3.9	8
		250	<b>212-285</b>	287	261	3.9	8

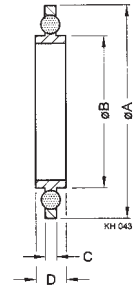



**SEALS** - continued

**Centering Ring with Fine Filter**

	DN ... ISO-K	Part No.	A	B	C	D
Inner ring: Stainless steel 304/-	63	<b>212-291</b>	62	69.8	3.9	8
Outer ring: Aluminum 6082/-	100	<b>212-292</b>	94	101.8	3.9	8
Seal: Elastomer FPM						
Snap ring: Stainless steel 304/-						
Filter grit: Stainless steel 304/-						
Filter: Stainless steel 316L/-						
Pore size 0.004 mm						
Degree of separation at 0.001 mm up to 98%						

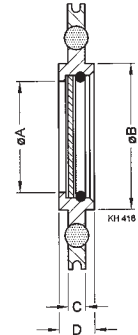

**O-Ring**

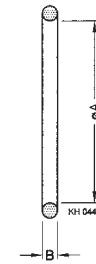
	DN ... ISO-K	Part No.	A	B	Set of
Elastomer CR	63	<b>212-386</b>	75.6	5.3	5 pcs.
	80	<b>212-387</b>	88.3	5.3	5 pcs.
	100	<b>212-388</b>	107.3	5.3	5 pcs.
	160	<b>212-389</b>	158.1	5.3	5 pcs.
	200	<b>212-390</b>	208.9	5.3	5 pcs.
	250	<b>212-391</b>	253.4	5.3	5 pcs.
	320	<b>212-356</b>	329.6	7	
	400	<b>212-357</b>	405.3	7	
	500	<b>212-358</b>	506.9	7	
Elastomer FPM	630	<b>212-359</b>	658.9	7	
	63	<b>212-392</b>	75.6	5.3	5 pcs.
	80	<b>212-393</b>	88.3	5.3	5 pcs.
	100	<b>212-394</b>	107.3	5.3	5 pcs.
	160	<b>212-395</b>	158.1	5.3	5 pcs.
	200	<b>212-396</b>	208.9	5.3	5 pcs.
Elastomer FPM	250	<b>212-397</b>	253.4	5.3	5 pcs.
	320	<b>212-366</b>	329.6	7	
	400	<b>212-367</b>	405.3	7	
	500	<b>212-368</b>	506.9	7	
	630	<b>212-369</b>	658.9	7	
	800	<b>212-370</b>	808	7	
	1000	<b>212-371</b>	1006	7	

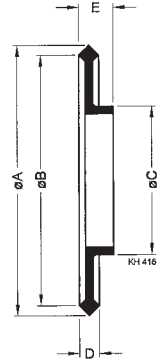

**SEALS** - continued

<b>Aluminum Seal</b>		DN ... ISO-K	Part No.	A	B	C	D	E
Aluminum annealed 6082/-	63	<b>212-301</b>	85.6	83	69.8	2.6	4.5	
	100	<b>212-302</b>	116.6	114	101.8	2.6	4.5	
	160	<b>212-303</b>	166.6	164	152.8	2.6	4.5	
	250	<b>212-305</b>	276.6	274	260.8	2.6	4.5	
Number of		Clamps	Claw Grips					
	DN 63 ISO -K	4						
	DN 100 ISO-K	6	8					
	DN 160 ISO-K	8	8					
	DN 250 ISO-K	12	12					



# ISO-K Clamp Flange Components

## FLANGES

<b>Blank Flange</b>	DN ... ISO-K	Part No.	A	B
Steel nickel plated A570/-	63	<b>212-001</b>	95	12
	100	<b>212-002</b>	130	12
	160	<b>212-003</b>	180	12
	250	<b>212-005</b>	290	12
Stainless steel 304/-	63	<b>212-011</b>	95	12
	80	<b>212-076</b>	110	12
	100	<b>212-012</b>	130	12
	160	<b>212-013</b>	180	12
	200	<b>212-014</b>	240	12
	250	<b>212-015</b>	290	12
	320	<b>212-016</b>	370	17
	400	<b>212-017</b>	450	17
	500	<b>212-018</b>	550	17
630	<b>212-019</b>	690	22	

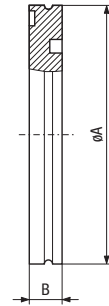

<b>Welding Flange</b>	DN ... ISO-K	Part No.	A	B	C	D	E
Steel -/1.0570	63	<b>212-021</b>	95	76.1	70.3	12	6
	100	<b>212-022</b>	130	108	102.2	12	6
Steel A570/-	160	<b>212-023</b>	180	159	153.2	12	6
	250	<b>212-025</b>	290	267	261	12	6
Stainless steel 304/-	63	<b>212-031</b>	95	76.1	71.5	12	6
	80	<b>212-078</b>	110	88.9	84.9	12	6
	100	<b>212-032</b>	130	108	102	12	6
	160	<b>212-033</b>	180	159	155	12	6
	200	<b>212-034</b>	240	219.1	213.9	12	6
	250	<b>212-035</b>	290	267	261	12	6
Stainless steel 304/-	320	<b>212-036</b>	370	324	318	17	8.5
	250	<b>212-385</b>	290	254	261	12	6
	250	<b>212-505</b>	290	273	261	12	5

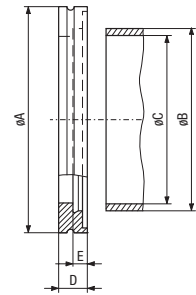

## FLANGES – continued

### Flange with Tube

	DN ... ISO-K	Part No.	A	B	C
Flange: steel -/1.0570	63	<b>212-041</b>	100	76.1	70.3
Tube: steel -/1.0831	100	<b>212-042</b>	100	108	102.2
	160	<b>212-043</b>	100	159	153.2
	250	<b>212-045</b>	100	267	261
Stainless steel 304/-	63	<b>212-051</b>	100	76.1	71.5
	100	<b>212-052</b>	100	108	104
	160	<b>212-053</b>	100	159	155
	200	<b>212-054</b>	100	219.1	213.1
	250	<b>212-055</b>	100	267	261
	320	<b>212-056</b>	100	324	318
	400	<b>212-057</b>	100	406	400
	500	<b>212-058</b>	100	508	500
	630	<b>212-059</b>	100	660	650
Stainless steel 304/-	250	<b>212-506</b>	100	273	267

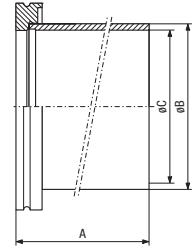

# ISO-K Clamp Flange Components

## PIPE FITTINGS

### Elbow 90°

	DN ... ISO-K	Part No.	A	B
Stainless steel 304/-	63	<b>212-101</b>	88	66
	100	<b>212-102</b>	108	100
	160*	<b>212-103</b>	138	150
	200*	<b>212-104</b>	178	213
	250*	<b>212-105</b>	208	250
	320*	<b>212-106</b>	250	318

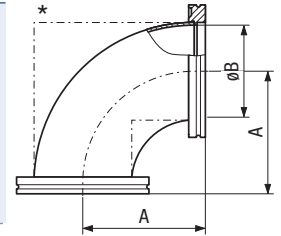

### Tee

	DN ... ISO-K	Part No.	A	B
Stainless steel 304/-	63	<b>212-111</b>	88	66
	100	<b>212-112</b>	108	100
	160	<b>212-113</b>	138	150
	200	<b>212-114</b>	178	213
	250	<b>212-115</b>	208	250
	320	<b>212-116</b>	250	318

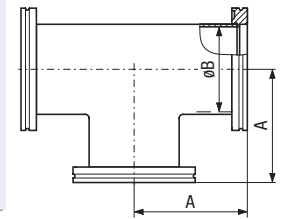

### Reducing Tee

	DN ... ISO-K	Part No.	A	B	C
Stainless steel 304/-	160/63	<b>212-196</b>	138	276	130
	160/100	<b>212-197</b>	138	276	131
	250/200	<b>212-198</b>	190	380	208

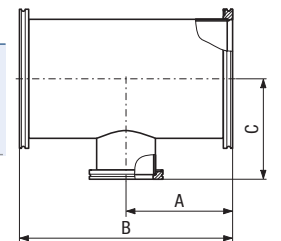

### Cross

	DN ... ISO-K	Part No.	A	B
Stainless steel 304/-	63	<b>212-121</b>	88	66
	100	<b>212-122</b>	108	100
	160	<b>212-123</b>	138	150
	200	<b>212-124</b>	178	213
	250	<b>212-125</b>	208	250

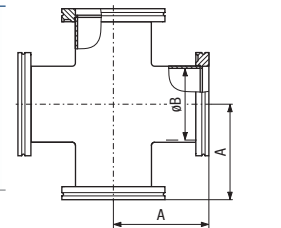

## PIPE FITTINGS - continued

### Reducing Cross

	DN ... ISO-K	Part No.	A	B	C	D	E
Stainless steel 304/-	63	<b>212-131</b>	88	44	66	64	59
	100	<b>212-132</b>	100	50	82	80	77
	160	<b>212-133</b>	100	50	107	107	105

1 x DN 16 ISO-KF, 1 x DN 25 ISO-KF, 1 x DN 40 ISO-KF

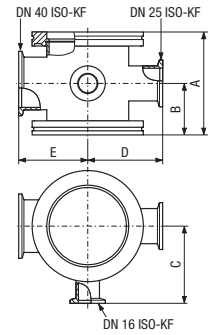

### Reducer

	DN ... ISO-K	Part No.	A
Stainless steel 303/-	80/63	<b>212-084</b>	50
	100/63	<b>212-161</b>	50
	160/100	<b>212-163</b>	50
	200/160	<b>212-166</b>	50
	250/160	<b>212-169</b>	50
	250/200	<b>212-170</b>	50

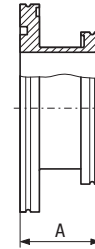

### Intermediate Piece

	DN ... ISO-K	Part No.	A	B
Stainless steel 304/-	63	<b>212-191</b>	100	70
	63	<b>212-192</b>	176	70

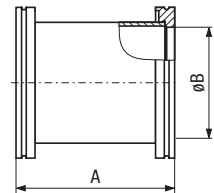

# ISO-K Clamp Flange Components

## BELLOWS / HOSE WITH FLANGES

<b>Bellows</b>	DN ... ISO-K	Part No.	A	B	C	D	E
Flanges: Stainless steel 304/-	63	<b>212-201</b>	132	20	20	66	30°
Bellow: Stainless steel 316Ti/-	100	<b>212-202</b>	132	28	28	95	30°
	160	<b>212-203</b>	150	22	22	153	14°
	200	<b>212-204</b>	150	20	20	213	12°
E = max. deviation from axis	250	<b>212-205</b>	200	30	30	261	13°
Max. internal pressure 1.5 bar	320	<b>212-206</b>	250	50	50	313	12°

A = unstressed length

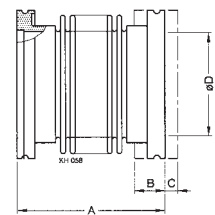

<b>Metal Hose</b>	DN ... ISO-K	Part No.	A	B	C
Flanges: Stainless steel 304/-	63	<b>212-211</b>	250	250	160
Bellow: Stainless steel 316Ti/-	63	<b>212-212</b>	500	250	160
	63	<b>212-213</b>	750	250	160
	63	<b>212-214</b>	1000	250	160
	100	<b>212-215</b>	250	370	240
	100	<b>212-216</b>	500	370	240
	100	<b>212-217</b>	750	370	240
Max. internal pressure 1.5 bar	100	<b>212-218</b>	1000	370	240

B = radius for multiple bending

C = radius for single bending

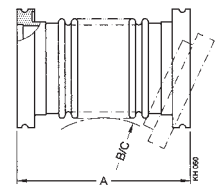

# ISO-K Clamp Flange Components

## TRANSITION PIECES

Adapter Flange	ISO-K / ISO-F	Part No.	A
Stainless steel 304/-	160/63	<b>212-152</b>	22
	160/100	<b>212-153</b>	25
	200/100	<b>212-155</b>	20
	200/160	<b>212-156</b>	25
	250/160	<b>212-159</b>	22

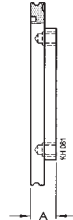

Adapter	ISO-K / ISO-KF	Part No.	A
Aluminum 6082/-	63/40	<b>212-171</b>	40
	63/50	<b>212-172</b>	45
Stainless steel 303/-	63/25	<b>212-176</b>	50
	63/40	<b>212-173</b>	40
	63/50	<b>212-174</b>	45
	100/40	<b>212-175</b>	40

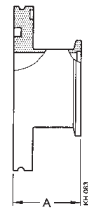

Adapter	ISO-CF / ISO-K	Part No.	A	B	C
Stainless steel 304/-	63/63	<b>213-271</b>	90	1	1
	100/100	<b>213-272</b>	90	1	1
	160/160	<b>213-273</b>	90	1.5	1.5

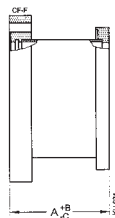

Adapter	DN ... ISO-K	Part No.	A	B
Aluminum 6082/-	63	<b>212-181</b>	51	76
	100	<b>212-182</b>	56	107
	160	<b>212-183</b>	56	156

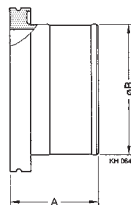

Sleeve with Hose Clamp	DN ... ISO-KF	Part No.	A	B	C	D	E
Sleeve: Elastomer CR	63	<b>212-186</b>	70	14	24	75	120
Hose clamp: Stainless steel 430/-	100	<b>212-187</b>	72	8	26	106	150
Max. internal pressure: 1 bar	160	<b>212-188</b>	72	8	26	155	200

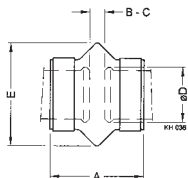



# ISO-K Clamp Flange Components

## PROTECTIVE LIDS

Protective Lids	DN ... ISO-K	Part No.	A	B	C
Polyethylene	63	<b>212-311</b>	102	95	18
	100	<b>212-312</b>	137	130	18
	160	<b>212-313</b>	187	180	18
	200	<b>212-314</b>	248	240	18.5
	250	<b>212-315</b>	297.5	290	18.5
	320	<b>212-316</b>	380	370	23.5
	400	<b>212-317</b>	461	450	23.5
	500	<b>212-318</b>	557	550	24
	630	<b>212-319</b>	697	690	29

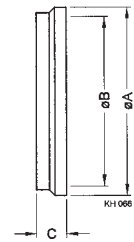

# ISO-F Fixed Flange Components

## FLANGE COMPONENTS

### Collar Flange with Retaining Ring

	DN ... ISO-F	Part No.	A	B	C
Flange:	63	<b>212-061</b>	12	95.5	130
DN 63 - 160: steel nickel plated -/1.0831	80	<b>212-081</b>	12	110.5	145
DN 200 - 630: steel nickel plated -/1.0037	100	<b>212-062</b>	12	130.5	165
	160	<b>212-063</b>	16	180.7	225
Retaining ring: steel nickel plated	200	<b>212-064</b>	16	240.7	285
	250	<b>212-065</b>	16	290.7	335
	320	<b>212-066</b>	20	370.8	425
	400	<b>212-067</b>	20	450.8	510
	500	<b>212-068</b>	20	550.8	610
	630	<b>212-069</b>	24	691	750

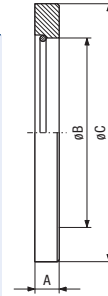

### Adapter Flange with ISO-K / ISO-F

	DN ... ISO-F	Part No.	A
Stainless steel 304/1.4301	160/63	<b>212-152</b>	22
	160/100	<b>212-153</b>	25
	200/100	<b>212-155</b>	20
	200/160	<b>212-156</b>	25
	250/160	<b>212-159</b>	22

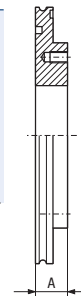

### Measurement Flange

	DN ... ISO-F	Part No.	A	B	C
Aluminum 6082/3.2315	100	<b>212-142</b>	30	165	M 8
	160	<b>212-143</b>	30	225	M 10
Stainless steel 304/1.4301	63	<b>212-146</b>	30	130	M 8
	100	<b>212-147</b>	30	165	M 8
	160	<b>212-148</b>	30	225	M 10

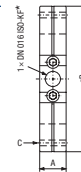

\*Claw grip DN 16 ISO-KF included

## FLANGE COMPONENTS – continued

### Set of Hexagon Bolts

	DN ... ISO-F	Part No.	A	B	Set of
Steel zinc plated	63-100	<b>212-241</b>	40	8	8 pcs.
	160-250	<b>212-242</b>	50	10	12 pcs.
	320-500	<b>212-243</b>	70	12	16 pcs.
	630	<b>212-244</b>	80	12	20 pcs.

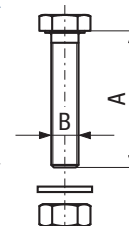

### Sealing Disk

	DN ... ISO-F	Part No.	A	B	C
Disk: aluminum 6082/3.2315	63	<b>212-321</b>	73	3.9	98
O-ring: elastomer CR	100	<b>212-322</b>	107	3.9	132
	160	<b>212-323</b>	160	3.9	185
	250	<b>212-325</b>	270	3.9	295
	320	<b>212-326</b>	330	5.6	375
	400	<b>212-327</b>	415	5.6	460
	500	<b>212-328</b>	515	5.6	560
	630	<b>212-329</b>	656	5.6	701
	800	<b>212-330</b>	825	5.6	870
	1000	<b>212-331</b>	1025	5.6	1070

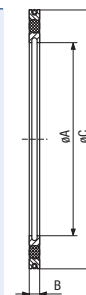

### O-Ring

	DN ... ISO-F	Part No.	A	B	Set of
Elastomer CR	63	<b>212-345</b>	80	5	5 pcs.
	100	<b>212-346</b>	110	5	5 pcs.
	160	<b>212-347</b>	165	5	5 pcs.
	250	<b>212-349</b>	265	5	5 pcs.
	320	<b>212-338</b>	325	8	
	400	<b>212-339</b>	412	8	
	500	<b>212-340</b>	510	8	
	630	<b>212-341</b>	640	8	
	800	<b>212-342</b>	820	8	
	1000	<b>212-343</b>	1023	8	

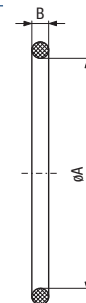

# UHV CF Components

## CONNECTION ELEMENTS

### Hexagon Bolts with Nuts

		DN ... CF	Part No.	A	B	Set of	Required torque
Bolt:	Stainless steel 316/1.4401	16	<b>213-401</b>	20	3.2	25 x M4	3.5 Nm
Washer:	Stainless steel 304/1.4301	40	<b>213-402</b>	35	5	25 x M6	10 Nm
Nut:	Stainless steel 316/1.4401	63	<b>213-403</b>	45	6.5	25 x M8	20 Nm
		100	<b>213-404</b>	50	6.5	25 x M8	20 Nm
		160	<b>213-405</b>	55	6.5	25 x M8	20 Nm
		200-250	<b>213-406</b>	60	6.5	25 x M8	20 Nm
		300	<b>213-408</b>	70	8	34 x M10	30 Nm
		350	<b>213-409</b>	70	8	38 x M10	30 Nm

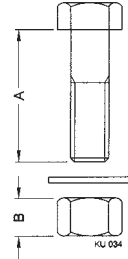

### Hexagon Bolts without Nuts

		DN ... CF	Part No.	A	Set of	Required torque
Bolt:	Stainless steel 316/1.4401	16	<b>213-411</b>	16	25 x M4	4 Nm
Washer:	Stainless steel 304/1.4301	40	<b>213-412</b>	25	25 x M6	10 Nm
		63-160	<b>213-413</b>	35	25 x M8	20 Nm

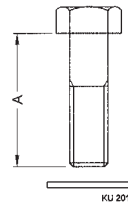

### Hexagon Bolts with Duo Nuts

		DN...CF	Part No.	A	B	C	Duo nut	Required torque
Bolt:	Stainless steel 316/1.4401	16	<b>213-421</b>	20	7	4	6 x M4/3	4 Nm
Washer:	Stainless steel 304/1.4301	40	<b>213-422</b>	35	10	5	6 x M6/3	10 Nm
Duo nut:	Stainless steel 316/1.4401	63	<b>213-423</b>	45	12	8	8 x M8/3	20 Nm
		100	<b>213-424</b>	50	12	8	16 x M8/8	20 Nm
		160	<b>213-425</b>	55	12	8	20 x M8/10	20 Nm

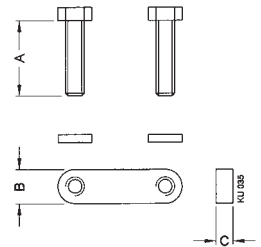

### Set of Stud Screws

		DN ... CF	Part No.	A	Set of	Required torque
Bolt:	Stainless steel 316/1.4401	16	<b>213-431</b>	20	6 x M4	4 Nm
Washer:	Stainless steel 304/1.4301	40	<b>213-432</b>	35	6 x M6	10 Nm
Nut:	Stainless steel 316/1.4401	63-100	<b>213-433</b>	45	16 x M8	20 Nm

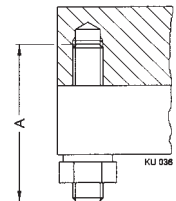

### Thread Lubricant

		Part No.	Temperature resistance
C100	28g	<b>214-231</b>	1000°C
Remains fully effective for at least 10 bakeout cycles			

# UHV CF Components

## SEALS

Quality copper gaskets and silver plated copper gaskets are strictly designed for use in high-end UHV applications. These gaskets, made of OFHC copper, are inspected, cleaned and individually packed to ensure maximum quality.

<b>Copper Gasket</b>	DN ... CF	Part No.	A	B	C	Set of
High quality	16	<b>213-451</b>	2.1	21.3	16.2	10 pcs.
Copper OFHC -/2.0040	40	<b>213-452</b>	2.1	48.1	39	10 pcs.
Individually packed	63	<b>213-453</b>	2.1	82.4	63.6	10 pcs.
	100	<b>213-454</b>	2.1	120.5	101.8	10 pcs.
	160	<b>213-455</b>	2.1	171.3	152.6	10 pcs.
	200	<b>213-456</b>	2.1	222.1	203.4	10 pcs.
	250	<b>213-457</b>	2.1	272.9	254.2	5 pcs.
	300	<b>213-458</b>	2.1	326.2	307	1 pcs.
	350	<b>213-459</b>	2.1	376.5	357	1 pcs.

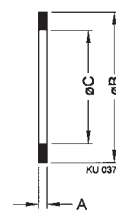

<b>Copper Gasket Silver Plated</b>	DN ... CF	Part No.	A	B	C	Set of
High quality	16	<b>213-461</b>	2.1	21.3	16.2	10 pcs.
Individually packed	40	<b>213-462</b>	2.1	48.1	39	10 pcs.
Copper OFHC -/2.0040	63	<b>213-463</b>	2.1	82.4	63.6	10 pcs.
Double silver plated	100	<b>213-464</b>	2.1	120.5	101.8	10 pcs.
	160	<b>213-465</b>	2.1	171.3	152.6	5 pcs.
	200	<b>213-466</b>	2.1	222.1	203.4	5 pcs.
	250	<b>213-467</b>	2.1	272.9	254.2	5 pcs.

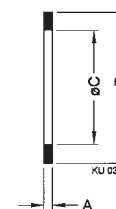

**SEALS** - continued

<b>FPM Seal</b>		DN ... CF	Part No.	A	B	C	D	Set of
Elastomer FPM	16	<b>213-391</b>	2	21	16			5 pcs.
	40	<b>213-392</b>	2.5	48.2	42			5 pcs.
	63	<b>213-393</b>	3.2	82.7	69.7	2.5		2 pcs.
	100	<b>213-394</b>	3.2	119.8	107.8	2.5		2 pcs.
	160	<b>213-395</b>	3.2	171.1	156	2.5		2 pcs.
	200	<b>213-396</b>	3.2	222.5	206	2.5		2 pcs.

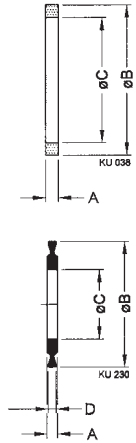

<b>FPM Seal with Support Ring</b>		DN ... CF	Part No.	A	B	C	D	Set of
Seal:	Elastomer FPM	250	<b>213-397</b>	5	266.5	248.3	256.2	1 pcs.
Support ring: Aluminum 6082/-								

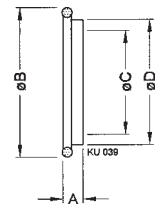

# UHV CF Components

## FLANGES

### Blank Flange

	DN ... CF-F	Part No.	A	B	C
Stainless steel 304/1.4301	16	<b>213-001</b>	7.5	14	1.4
	40	<b>213-002</b>	13	38	1.4
	63	<b>213-003</b>	17.5	66	1.4
	100	<b>213-004</b>	20	104	1.4
	160	<b>213-005</b>	22	155	1.4
	200	<b>213-006</b>	24.5	205	1.4
	250	<b>213-007</b>	2405	256	1.4
Stainless steel 316L/1.4435	300	<b>213-008</b>	28.5	306	1.4
	350	<b>213-009</b>	28.5	356	1.4
Stainless steel 316LN/1.4429	16	<b>213-101</b>	7.5	14	1.4
	40	<b>213-102</b>	13	38	1.4
	63	<b>213-103</b>	17.5	66	1.4
	100	<b>213-104</b>	20	104	1.4
	160	<b>213-105</b>	22	155	1.4
	200	<b>213-106</b>	24.5	205	1.4
	250	<b>213-107</b>	24.5	256	1.4

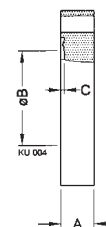

### Blank Flange, Rotatable

	DN ... CF-R	Part No.	A	B	C	D	E
Stainless steel 304/1.4301	16	<b>213-011</b>	7.5	5.8	18.6	14	1.4
	40	<b>213-012</b>	13	7.6	41	38	1.4
	63	<b>213-013</b>	17.5	12.6	71	66	1.4
	100	<b>213-014</b>	20	14.3	109	104	1.4
	160	<b>213-015</b>	22	15.8	160	155	1.4
	200	<b>213-016</b>	24.5	17.1	206	205	1.4
	250	<b>213-017</b>	24.5	18	257	256	1.4
Stainless steel 316LN/1.4429	16	<b>213-111</b>	7.5	5.8	18.6	14	1.4
	40	<b>213-112</b>	13	7.6	41	38	1.4
	63	<b>213-113</b>	17.5	12.6	71	66	1.4
	100	<b>213-114</b>	20	14.3	109	104	1.4
	160	<b>213-115</b>	22	15.8	160	155	1.4
	200	<b>213-116</b>	24.5	17.1	206	205	1.4
	250	<b>213-117</b>	24.5	18	257	256	1.4

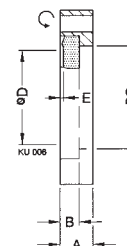

## FLANGES - continued

### Welding Flange

	DN ... CF-F	Part No.	A	B	C	D	E
Stainless steel 304/1.4301	16	<b>213-021</b>	7.5	3.3	17.2	18	1
	40	<b>213-022</b>	13	7.5	39.5	40	1.5
	63	<b>213-023</b>	17.5	8	66	70	2
	100	<b>213-024</b>	20	9	104	108	2
	160	<b>213-025</b>	22	10	155	159	2
	200	<b>213-026</b>	24.5	12	205	205	2.5
	250	<b>213-027</b>	24.5	12	256	256	3
Stainless steel 316L/1.4435	300	<b>213-028</b>	28.5	15.8	306	306	3
	350	<b>213-029</b>	28.5	15.8	356	356	3
Stainless steel 316LN/1.4429	16	<b>213-121</b>	7.5	3.3	17.2	18	1
	40	<b>213-122</b>	13	7.5	39.5	40	1.5
	63	<b>213-123</b>	17.5	8	66	70	2
	100	<b>213-124</b>	20	9	104	108	2
	160	<b>213-125</b>	22	10	155	159	2
	200	<b>213-126</b>	24.5	12	205	205	2.5
	250	<b>213-127</b>	24.5	12	256	256	3

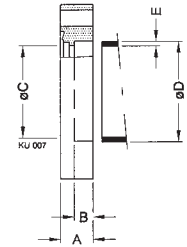

### Welding Flange, Rotatable

	DN ... CF-R	Part No.	A	B	C	D	E
Stainless steel 304/1.4301	16	<b>213-041</b>	7.5	3.3	17.2	18	1
	40	<b>213-042</b>	13	7.5	39.5	40	1.5
	63	<b>213-043</b>	17.5	8	66	70	2
	100	<b>213-044</b>	20	9	104	108	2
	160	<b>213-045</b>	22	10	155	159	2
	200	<b>213-046</b>	24.5	12	205	205	2.5
	250	<b>213-047</b>	24.5	12	256	256	3
Stainless steel 316LN/1.4429	16	<b>213-141</b>	7.5	3.3	17.2	18	1
	40	<b>213-142</b>	13	7.5	39.5	40	1.5
	63	<b>213-143</b>	17.5	8	66	70	2
	100	<b>213-144</b>	20	9	104	108	2
	160	<b>213-145</b>	22	10	155	159	2
	200	<b>213-146</b>	24.5	12	205	205	2.5
	250	<b>213-147</b>	24.5	12	256	256	3

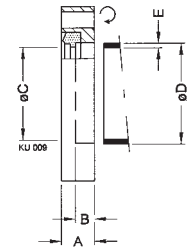



## FLANGES - continued

### Welding Flange with Tapped Holes

	DN ... CF-F	Part No.	A	B	C	D	E	
Stainless steel 304/1.4301	16	<b>213-031</b>	7.5	3.3	17.2	18	1	6xM4
	40	<b>213-032</b>	13	7.5	39.5	40	1.5	6xM6
	63	<b>213-033</b>	17.5	8	66	70	2	8xM8
	100	<b>213-034</b>	20	9	104	108	2	16x M8

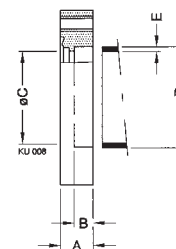

### Welding Flange for Gauges

	DN ... CF-F	Part No.	A	B	C	D	E	F	G	F
Stainless steel 304/1.4301	40	<b>213-092</b>	24	17	38	69.5	1.75	48	10	4

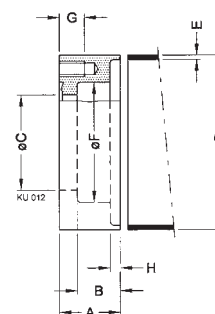

### Flange with Tube

	DN ... CF-F	Part No.	A	B	C	D
Stainless steel 304/1.4301	16	<b>213-051</b>	38	17.2	18	1
	40	<b>213-052</b>	63	39.5	40	1.6
	63	<b>213-053</b>	105	66	70	2
	100	<b>213-054</b>	135	104	108	2
	160	<b>213-055</b>	167	155	159	2

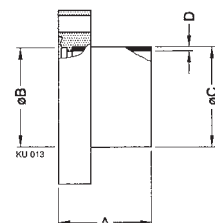

### Flange with Tube, Rotatable

	DN ... CF-R	Part No.	A	B	C	D
Stainless steel 304/1.4301	16	<b>213-061</b>	38	17.2	18	1
	40	<b>213-062</b>	63	39.5	40	1.6
	63	<b>213-063</b>	105	66	70	2
	100	<b>213-064</b>	135	104	108	2
	160	<b>213-065</b>	167	155	159	2

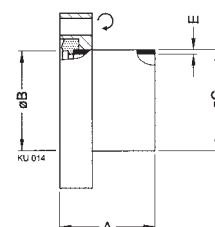

FLANGES - continued

**Reducing Flange  
CF-F/CF-F**

	DN ... CF-F	Part No.	A	B	C	D	
Stainless steel 304/1.4301	40/16	<b>213-071</b>	13	16	22	5.5	6xM4
	63/40	<b>213-073</b>	17.5	39	50	9	6xM6
	100/40	<b>213-075</b>	20	39	55	9	6xM6
	100/63	<b>213-076</b>	20	66	85	11	8xM8
	160/40	<b>213-078</b>	22	39	60	9	6xM6
	160/100	<b>213-080</b>	22	104	120	11	16xM8
Stainless steel 316LN/1.4429	40/16	<b>213-171</b>	13	16	22	5.5	6xM4
	63/40	<b>213-173</b>	17.5	39	50	9	6xM6
	100/40	<b>213-175</b>	20	39	55	9	6xM6
	100/63	<b>213-176</b>	20	66	85	11	8xM8
	160/40	<b>213-178</b>	22	39	60	9	6xM6
	160/100	<b>213-180</b>	22	104	120	11	16xM8

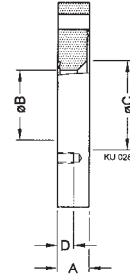

# UHV CF Components

## PIPE FITTINGS

### Intermediate Piece

	DN ... CF	Part No.	A	B	C	D
Stainless steel 304/1.4301	16	<b>213-201</b>	76	0.5	0.5	16
	40	<b>213-202</b>	126	1	1	37
	63	<b>213-203</b>	210	1	1	104
	100	<b>213-204</b>	270	1	1	104
	160	<b>213-205</b>	334	1.5	1.5	155

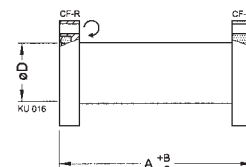

### Intermediate Piece, Insulated

	DN ... CF	Part No.	A	B	C	D	E	F	G
Flanges: Stainless steel 304/1.4301	40	<b>213-212</b>	70	1	1	25	30	34.5	44
Insulator: Ceramic Al <sub>2</sub> O <sub>3</sub>	63	<b>213-213</b>	90	1	1	53	45	66	65
Transition insulator/flange: FeNi									
Bakeout temperature: 350 °C									
G = Surface leakage 20 kV at 10 <sup>-4</sup> mbar									

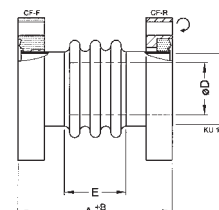

### Reducer CF/CF

	DN ... CF	Part No.	A	B	C	D
Stainless steel 304/1.4301	40/16	<b>213-221</b>	45	1	1	16
	63/40	<b>213-223</b>	75	1	1	37
	100/40	<b>213-225</b>	75	1	1	37
	100/63	<b>213-226</b>	95	1	1	66
	160/100	<b>213-230</b>	105	1.5	1.5	104

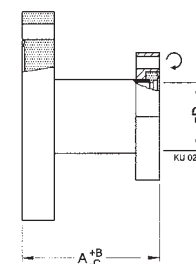

### Elbow 90°

	DN ... CF	Part No.	A	B	C	D
Stainless steel 304/1.4301	16	<b>213-301</b>	38	0.5	0.5	15
	40	<b>213-302</b>	63	0.5	0.5	38
	63	<b>213-303</b>	105	1	1	66
	100	<b>213-304</b>	135	1	1	100
	160	<b>213-305</b>	167	1.5	1.5	150

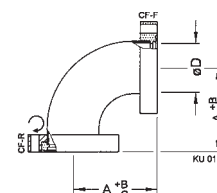

## PIPE FITTINGS - continued

### TEE

	DN ... CF	Part No.	A	B	C	D
Stainless steel 304/1.4301	16	<b>213-311</b>	38	0.5	0.5	15
	40	<b>213-312</b>	63	0.5	0.5	38
	63	<b>213-313</b>	105	1	1	66
	100	<b>213-314</b>	135	1	1	100
	160	<b>213-315</b>	167	1.5	1.5	150

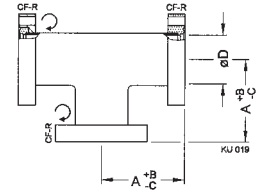

### Cross

	DN ... CF	Part No.	A	B	C	D
Stainless steel 304/1.4301	16	<b>213-321</b>	38	0.5	0.5	15
	40	<b>213-322</b>	63	0.5	0.5	38
	63	<b>213-323</b>	105	1	1	66
	100	<b>213-324</b>	135	1	1	100
	160	<b>213-325</b>	167	1.5	1.5	150

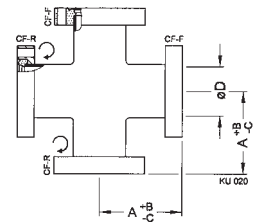

### Double Cross Piece

	DN ... CF	Part No.	A	B	C	D
Stainless steel 304/1.4301	40	<b>213-332</b>	63	0.5	0.5	38
3 rotatable flanges	63	<b>213-333</b>	105	1	1	66
3 fix flanges	100	<b>213-334</b>	135	1	1	100
	160	<b>213-335</b>	167	1.5	1.5	150

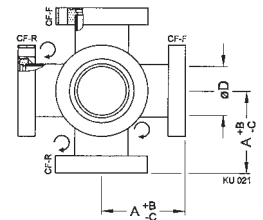

### Reducing Cross

	DN ... CF	Part No.	A	B	C	D	E	F
Stainless steel 304/1.4301	100	<b>213-342</b>	135	1	1	67.5	106	84
2 x DN 16 CF-F								
2 x DN 40 CF-F								

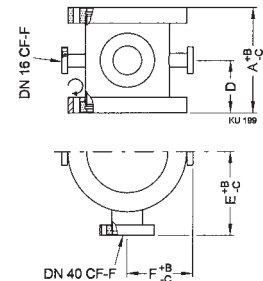

# UHV CF Components

## BELLOWS / HOSE WITH FLANGES, COMPENSATOR

### Compensator

	DN...CF	Part No.	A	B	C	D	E	F	G
Flanges: Stainless steel 304/1.4301	40	<b>213-346</b>	120	10	0	36.8	100	10	10°
Bellows: Stainless steel 316Ti/1.4571	63	<b>213-347</b>	130	20	0	62	154	13	12°
	100	<b>213-348</b>	127	30	0	93	192	13	12°
Max. internal pressure for DN 40:									4 bar
Max. internal pressure for DN 63/100:									1.5 bar

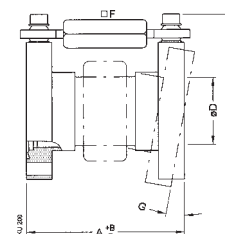

### Bellows

	DN...CF	Part No.	A	B	C	D	E	F	G
Flanges: Stainless steel 304/1.4301	16	<b>213-351</b>	76	1.5	1.5	15	22	16	21°
Bellows: Stainless steel 316Ti/1.4571	40	<b>213-352</b>	126	2	2	40	55	36.8	7.5°
A = unstressed length	63	<b>213-353</b>	139	2	2	62	80	66	37°
Max. internal pressure DN 40:	100	<b>213-354</b>	142	2	2	92	116	102	28°
Max. internal pressure DN 63 ... 160:	160	<b>213-355</b>	250	3	3	154	187	153	16°

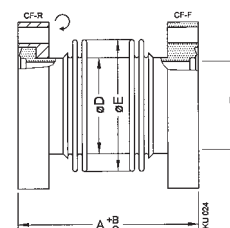

### Flexible Metal

	DN...CF	Part No.	A	B	C	D	E	F	G
Flanges: Stainless steel 304/1.4301	16	<b>213-361</b>	250	23	16	15	22.5	70	50
Bellows: Stainless steel 316Ti/1.4571	16	<b>213-362</b>	500	23	16	15	22.5	70	50
	16	<b>213-363</b>	750	23	16	15	22.5	70	50
	16	<b>213-364</b>	1000	23	16	15	22.5	70	50
F = radius for multiple bending	40	<b>213-365</b>	250	46	36.8	40.5	53	130	100
G = radius for single bending	40	<b>213-366</b>	500	46	36.8	40.5	53	130	100
Max. internal pressure: 5 bar	40	<b>213-368</b>	1000	46	36.8	40.5	53	130	100

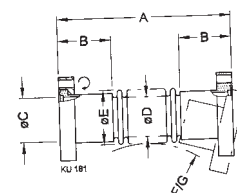

# UHV CF Components

## TRANSITION PIECES

### Adapter CF-F/ISO-KF

	DN...CF-F	Part No.	A	B
Stainless steel 304/1.4301	16/16	<b>213-251</b>	35	16
	16/25	<b>213-252</b>	35	16
	40/16	<b>213-254</b>	30	16
	40/25	<b>213-255</b>	30	26
	40/40	<b>213-256</b>	50	37
	63/40	<b>213-259</b>	35	41
	100/40	<b>213-262</b>	50	41

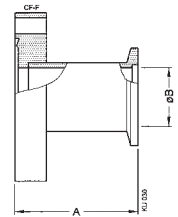

### Adapter CF-F/ISO-K

	DN ... CF-F	Part No.	A	B	C	D
Stainless steel 304/1.4301	63/63	<b>213-271</b>	90	1	1	66
	100/100	<b>213-272</b>	90	1	1	104
	160/160	<b>213-273</b>	90	1.5	1.5	153

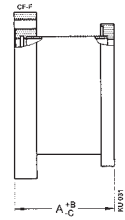

# UHV CF Components

## PROTECTIVE LIDS

### Protective Lids

	DN ... CF	Part No.	A	B	C
Polyethylene	16	<b>213-441</b>	36	34	9.5
	40	<b>213-442</b>	71.5	69.5	17.5
	63	<b>213-443</b>	115.5	113.5	22
	100	<b>213-444</b>	154	152	24.5
	160	<b>213-445</b>	205	202.5	27
	200	<b>213-446</b>	263	254	36
	250	<b>213-447</b>	315	306	36





[www.inficon.com](http://www.inficon.com)   [reachus@inficon.com](mailto:reachus@inficon.com)

Due to our continuing program of product improvements, specifications are subject to change without notice.

tiic85e1-d ©2010 INFICON