



Vacuum Control Catalog 2009

VACUUM GAUGES, VALVES, FITTINGS
AND FEEDTHROUGHS



Table of Contents

VACUUM GAUGES

SKY[®] Capacitance Diaphragm Gauge

CDG025D, CDG025D-S	A1
CDG045	A5
CDG100D	A10
CDG160D, CDG200D	A15
AllCeramic™ CDG025-C	A20
AllCeramic™ CDG160A-C / CDG160A-CS	A22

Bayard-Alpert Pirani Gauge

BPG400	A25
BPG402-S	A29

High Pressure Hot Ionization Pirani Gauge

HPG400	A33
--------------	-----

Bayard-Alpert Pirani Capacitance Diaphragm Gauge

TripleGauge [®] BCG450	A37
---------------------------------------	-----

Pirani Standard Gauge

PSG050 / PSG051	A42
PSG100-S, PSG101-S	A44
PSG500/-S, PSG502-S, PSG510-S, PSG512-S	A47

Pirani Capacitance Diaphragm Gauge

PCG400, PCG410	A51
----------------------	-----

Penning Gauge

PEG100	A54
--------------	-----

Inverted Magnetron Pirani Gauge

MPG400/401	A57
------------------	-----

Vacuum Gauge Controllers

VGC401, VGC402, VGC403	A60
------------------------------	-----

Vacuum Switch

VSA100A	A62
VSC150A	A64

Calibration Service

Vacuum Gauges	A68
---------------------	-----

VACUUM FEEDTHROUGHS

Rotary Feedthroughs ISO-KF / ISO-K

FRH DN 16 - DN 63	B1
-------------------------	----

Rotary Feedthroughs CF

FRU DN 16 - DN 40	B3
-------------------------	----

Rotary/Linear Motion Feedthroughs ISO-KF

FCH DN 16 - DN 40	B5
-------------------------	----

Linear Motion Feedthroughs CF

FPU DN 16 - DN 40	B7
-------------------------	----

Electrical Feedthroughs

DN 16 ISO-KF	B9
DN 40 ISO KF	B11
DN 16 CF	B13
DN 40 CF	B15
DN 40 ISO KF	B17

Coaxial Feedthroughs ISO-KF / CF-F

BNC / MHV DN 16 - 40	B19
----------------------------	-----

Vacuum Feedthroughs

METAL-CERAMIC CONNECTIONS	B21
---------------------------------	-----

Liquid Feedthroughs ISO-KF / CF-F

DN 40	B23
-------------	-----

Viewports

DN 25 - DN 50 ISO-KF	B25
DN 63 - DN 160 ISO-K	B27
DN 16 - DN 160 CF	B29
DN 63 - DN 160 ISO-F	B31

Vacuum Feedthroughs

VACUUM BALL BEARINGS	B33
LUBRICANTS AND SEALING MATERIALS	B35

VACUUM VALVES

Angle and Inline Valves (VAH, VAP, VAM, VIM)

ISO-KF DN 5 manually, pneumatically, solenoid	C1
---	----

Angle and Inline Valves (VAH, VIH, VAP, VIP)

ISO-KF DN16 - 40 manually.	C4
ISO-KF DN16 - 40 manually (Diaphragm Valves).	C8
ISO-KF DN16 - 40 pneumatically	C10
ISO-KF DN16 - 40 solenoid (VAP, VIP)	C14
ISO-KF DN16 - 40 solenoid (VAM).	C18
ISO-KF DN63 manually, pneumatically	C21
ISO-KF DN100 manually, pneumatically	C24
ISO-KF DN160 pneumatically	C27

Butterfly Valves (VBH, VBP)

ISO-KF DN63 - 160 manually	C29
ISO-KF DN63 - 250 pneumatically	C31

Dosing Valves (VDH)

ISO-KF DN10 manually (coarse gas dosing)	C37
ISO-KF DN16 manually (fine gas dosing / shut-off)	C38

Dosing Systems (VDM, VDE, VCE, VCC, VCA)

All-Metal Dosing Valves and System	C40
Gas Dosing Systems	C43
Solenoid Control Valves	C44

All-Metal Angle Valves (VAH)

CF-R DN16 - 63 manually	C50
-----------------------------------	-----

Venting Valves (VH, WM, VIN)

ISO-KF DN10 manually	C52
ISO-KF DN10 solenoid.	C53
ISO-KF DN10 solenoid (power failure)	C55

Safety Valves (VSM)

ISO-KF DN16 - 40	C56
ISO-KF DN63 - 100	C56

Pressure Relief Valve (VSA)

ISO-KF DN16	C58
-----------------------	-----

Ball Valves

ISO-KF DN10 - 40	C59
----------------------------	-----

VACUUM FITTINGS

ISO-KF Small Flange Components

CONNECTION ELEMENTS	D1
SEALS	D3
FLANGES	D6
PIPE FITTINGS	D7
BELLOWS/HOSE WITH FLANGES	D9
TRANSITION PIECES	D11
HOSE, HOSE CONNECTION	D14

ISO-K Clamp Flange Components

CONNECTION ELEMENTS	D16
SEALS	D17
FLANGES	D20
PIPE FITTINGS	D22
BELLOWS / HOSE WITH FLANGES	D24
TRANSITION PIECES	D25
PROTECTIVE LIDS	D26

ISO-F Fixed Flange Components

FLANGE COMPONENTS	D27
-------------------------	-----

UHV CF Components

CONNECTION ELEMENTS	D29
SEALS	D30
FLANGES	D32
PIPE FITTINGS	D36
BELLOWS / HOSE WITH FLANGES, COMPENSATOR	D38
TRANSITION PIECES	D39
PROTECTIVE LIDS	D40

Website



Vacuum Gauges

VACUUM GAUGES

SKY[®] Capacitance Diaphragm Gauge

CDG025D, CDG025D-S	A1
CDG045	A5
CDG100D	A10
CDG160D, CDG200D	A15
AllCeramic™ CDG025-C	A20
AllCeramic™ CDG160A-C / CDG160A-CS	A22

Bayard-Alpert Pirani Gauge

BPG400	A25
BPG402-S	A29

High Pressure Hot Ionization Pirani Gauge

HPG400	A33
--------------	-----

Bayard-Alpert Pirani Capacitance Diaphragm Gauge

TripleGauge® BCG450	A37
---------------------------	-----

Pirani Standard Gauge

PSG050 / PSG051	A42
PSG100-S, PSG101-S	A44
PSG500/-S, PSG502-S, PSG510-S, PSG512-S	A47

Pirani Capacitance Diaphragm Gauge

PCG400, PCG410	A51
----------------------	-----

Penning Gauge

PEG100	A54
--------------	-----

Inverted Magnetron Pirani Gauge

MPG400/401	A57
------------------	-----

Vacuum Gauge Controllers

VGC401, VGC402, VGC403	A60
------------------------------	-----

Vacuum Switch

VSA100A	A62
VSC150A	A64

Calibration Service

Vacuum Gauges	A68
---------------------	-----

SKY® Capacitance Diaphragm Gauge

CDG025D, CDG025D-S

The INFICON SKY CDG025D Capacitance Diaphragm Gauge line of highly accurate temperature compensated manometers is designed for stable performance in harsh manufacturing tool environments. Advanced digital electronics improve gauge performance and offer easy handling features such as one pushbutton zero function and setpoint adjustment. The corrosion resistant ultra pure ceramic sensor provides excellent zero stability with a long life expectancy of several million pressure cycles, including atmospheric bursts. A unique sensor shielding (patent pending) protects the gauge from process contamination. A robust mechanical design and digital electronics improve EMC compatibility, long term stability and temperature compensation. The CDG025D sets new standards for fast stability after power on and fast recovery from atmospheric pressure exposure.



Advantages

- Full scale ranges from 100 mTorr ... 1000 Torr
- Fast stability after power on
- Fast recovery from atmospheric pressure
- Corrosion resistant ceramic sensor
- Excellent long term signal stability
- Temperature compensated
- Sensor protected from contamination
- One pushbutton zero function
- Wide range power supply
- 2 setpoints (optional)
- RS232 interface (optional)

Applications

- Semiconductor manufacturing equipment for Etch, CVD, PVD, ALD
- Data storage and display manufacturing equipment
- Industrial vacuum equipment
- General high accuracy pressure measurement

CDG025D, CDG025D-S (continued)

Ordering Information
CDG025D, temperature compensated

Full Scale Range			Flange type			
Torr	Pascal	mbar	1/2" tube	DN 16 ISO-KF	DN 16 CF-R	8 VCR®
1000	133,322	1333	375-000	375-001	375-002	375-003
100	13,332	133	376-000	376-001	376-002	376-003
10	1,333	13.3	377-000	377-001	377-002	377-003
1	133	1.3	378-000	378-001	378-002	378-003
0.1	13.3	0.13	379-000	379-001	379-002	379-003

CDG025D, with 2 setpoints and RS232 interface, temperature compensated

Full Scale Range			Flange type			
Torr	Pascal	mbar	1/2" tube	DN 16 ISO-KF	DN 16 CF-R	8 VCR®
1000	133,322	1333	375-300	375-301	375-302	375-303
–	110,000	1,100	375-500	375-501	375-502	375-503
200	26,664	267	382-300	382-301	382-302	382-303
100	13,332	133	376-300	376-301	376-302	376-303
–	10,000	100	376-500	376-501	376-502	376-503
20	2,666	26.7	383-300	383-301	383-302	383-303
10	1,333	13.3	377-300	377-301	377-302	377-303
–	1,000	10	377-500	377-501	377-502	377-503
1	133	1.3	378-300	378-301	378-302	378-303
–	100	1	378-500	378-501	378-502	378-503
0.25	33.3	0.33	385-300	385-301	385-302	385-303
0.1	13.3	0.13	379-300	379-301	379-302	379-303
–	10	0.1	379-500	379-501	379-502	379-503

bold = standard products

Other flange types and full scale ranges on request.

CDG025D, CDG025D-S (continued)

Specifications (standard products)

Measurement Range F.S. (Full Scale)	Torr Pa mbar	1000 133,322 1333	100 13,332 133	10 1,333 13.3	1 133 1.3	0.1 13 0.13	
Accuracy ¹⁾	% of reading	0.2	0.2	0.2	0.2	0.5	
Temperature effect on zero	% F.S./°C	0.005	0.005	0.005	0.015	0.02	
on span	% of reading/°C	0.01	0.01	0.01	0.01	0.03	
Resolution	% F.S.	0.003	0.003	0.003	0.003	0.003	
Pressure, max.	kPa (absolute)	400	260	260	260	130	
Lowest reading	% F.S.	0.01					
Lowest suggested reading	% F.S.	0.05					
Lowest suggested control pressure	% F.S.	0.5					
Temperature Operation (ambient)	°C	+5 ... +50					
Bakeout (at flange) ²⁾	°C	≤110					
Storage	°C	-40 ... +65					
Supply voltage	VDC	14 ... 30					
Power consumption	W	≤1					
Output signal (analog)	VDC	0 ... +10					
Response time	ms	30					130
Degree of protection		IP 30					
Standards		EN 61000-6-2, EN 61000-6-3, EN 61010, UL 61010-1, CSA 22.2 No.61010-1, RoHS					
Electrical connection		D-sub, 15 pole, male					
Setpoint ³⁾		two setpoints (SP1, SP2)					
Relay contact	VDC / ADC	30 / ≤0.5					
Hysteresis	% F.S.	1					
Materials exposed to vacuum		Aluminum oxide ceramic (Al ₂ O ₃), Vacon 70 ⁴⁾ , stainless steel (AISI 316L ⁵⁾ , AgCuTi hard solder, sealing glass					

¹⁾ Non-linearity, hysteresis, repeatability at 25°C ambient operating temperature without temperature effects after 2 hours operation.

²⁾ Non-Operation.

³⁾ CDG025D-S only.

⁴⁾ 28% Ni, 23% Co, 49% Fe

⁵⁾ 18% Cr, 10% Ni, 3% Mo, 69% Fe

Specifications (other ranges)

Measurement Range F.S. (Full Scale)	Torr Pa mbar	– 110,000 1000	200 26,664 267	– 10,000 100	20 2,666 26.7	– 1,000 10	– 100 1	0.25 33.3 0.33	– 10 0.1
Accuracy ¹⁾	% of reading	0.2	0.2	0.2	0.2	0.2	0.2	0.25	0.5
Temperature effect on zero	% F.S./°C	0.005	0.005	0.005	0.005	0.005	0.015	0.02	0.02
on span	% of reading/°C	0.01	0.01	0.01	0.01	0.01	0.01	0.03	0.03
Resolution	% F.S.	0.003	0.003	0.003	0.003	0.003	0.003	0.003	0.003
Pressure, max.	kPa (absolute)	400	260	260	260	260	260	130	130

For further specifications, see table above.

CDG025D, CDG025D-S (continued)

Dimensions, Internal Volume, Weight

mm (inch)

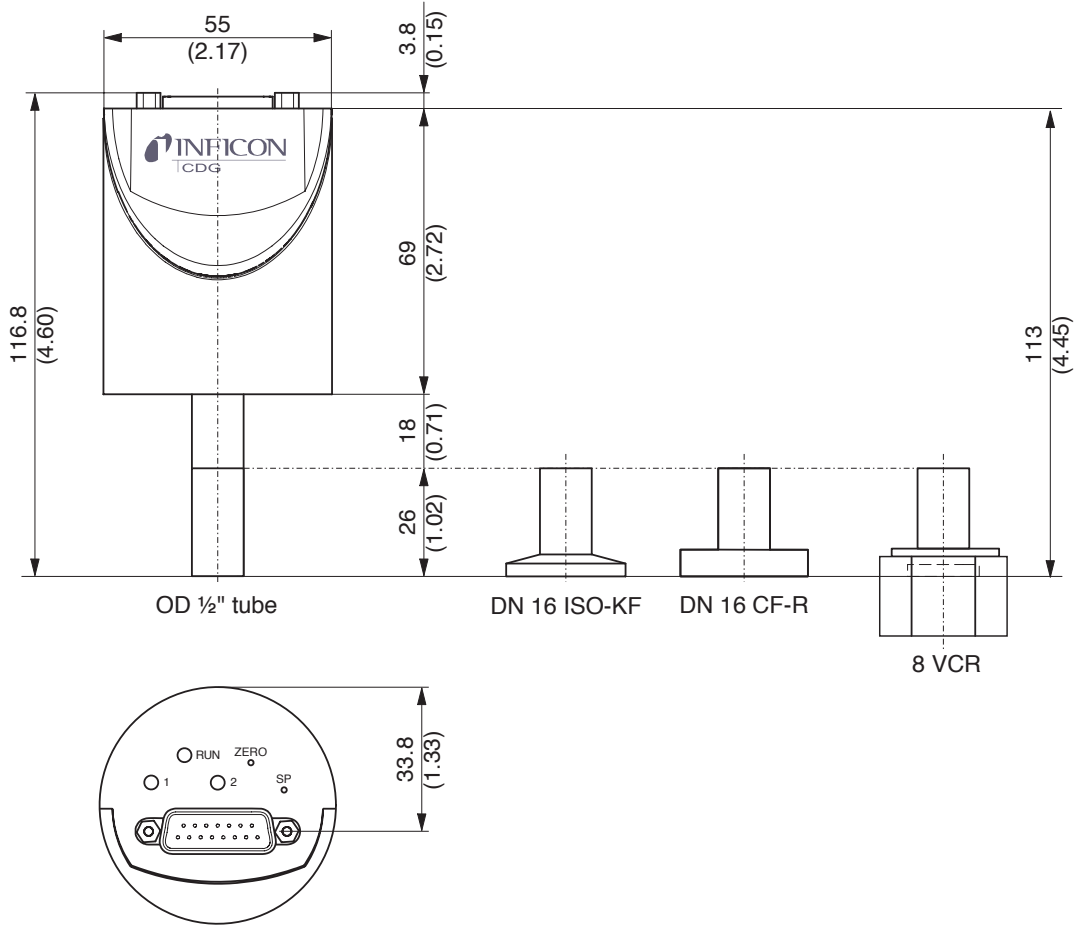

		1/2" tube	DN 16 ISO KF	DN 16 CF-R	8 VCR®
Internal volume	cm ³ (inch ³)	3.6 (0.22)	3.6 (0.22)	3.6 (0.22)	3.6 (0.22)
Weight	g	260	270	280	290

SKY® Capacitance Diaphragm Gauge

CDG045D

INFICON SKY CDG045D manometers are your best choice for highly accurate total pressure measurement and control. CDG045D gauges are temperature controlled at 45°C for superior signal stability and repeatability. They are available for full scale ranges from 100 mTorr to 1000 Torr, with all common flange types and fieldbus interfaces and provide a linear 0 to 10 V, gas type independent, pressure signal. INFICON capacitance manometers use a corrosion proof ultra pure alumina ceramic diaphragm. The advantages of the ceramic sensor are better signal stability, faster recovery from atmosphere, short warm up time and an extraordinary lifetime. INFICON CDG are high quality, cost effective pressure sensors for demanding vacuum applications.



Advantages

- Lower CoO (cost of ownership), 50% faster warm up, energy efficient low power consumption
- Easy integration, wide variety of full scales, flanges and interfaces, standard with two set points
- Easy one push button or remote signal zero command, zero offset adjustable
- Diagnostic port for quick service and maintenance
- Two year warranty, longer lifetime with advanced heating concept and gauge protection
- No long term recalibration due to excellent signal stability and repeatability, even in harsh plasma applications
- Compliance & standards: CE, EN, UL, SEMI, RoHS

Applications

- Etch, CVD, PVD and other semiconductor production processes
- Chemical and corrosive vacuum processes
- General thin film and vacuum processes
- Reference sensor for monitoring of test instruments according to international standards
- Transfer standard for traceability measurements

CDG045 (continued)

Ordering Information

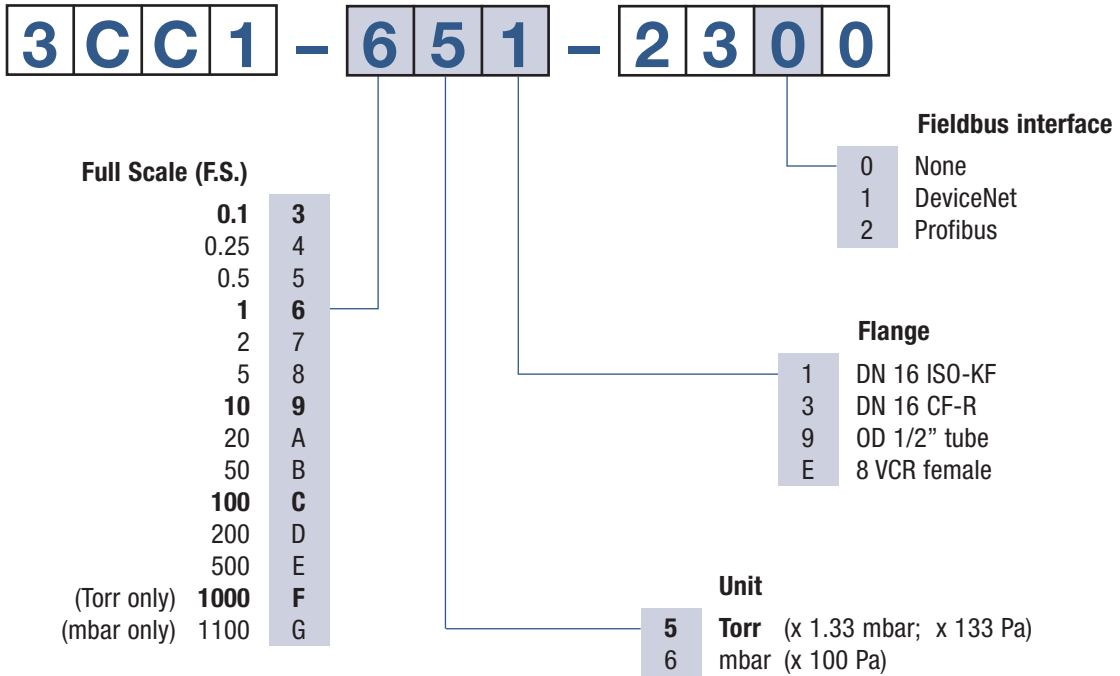

bold = standard products

Other flange types and full scale ranges (F.S.) on request.

Accessories

	Diagnostic
Communication adapter (2 m) for PC RS232 serial port	303-333

Software to run the diagnostic functions on Windows NT, XP can be downloaded from our website.

CDG045 (continued)

Specifications (Torr based standard products)

Measurement Range F.S. (Full Scale)	Torr Pa mbar	1000 133,322 1333	100 13,332 133	10 1,333 13.3	1 133 1.3	0.1 13 0.13
Accuracy ¹⁾	% of reading	0.15				
Temperature effect on zero	% F.S./°C	0.0025				0.005
on span	% of reading/°C	0.01				
Pressure, max.	kPa (absolute)	400	260			130
Resolution	% F.S.	0.003				
Lowest reading	% F.S.	0.01				
Lowest suggested reading	% F.S.	0.05				
Lowest suggested control pressure	% F.S.	0.5				
Temperature Operation (ambient)	°C	+10 ... +40				
Bakeout at flange	°C	≤110				
Storage	°C	-40 ... +65				
Supply voltage		+14 ... +30 VDC or ±15 V (±5%)				
Power consumption During Heat up	W	≤12				
At operating temperature	W	≤8				
Output signal (analog)	VDC	0 ... +10				
Response time	ms	30				130
Degree of protection		IP 40				
Standards		EN 61000-6-2, EN 61010, UL 61010-1, CSA 22.2 No.61010-1, SEMI S-2				
Electrical connection		D-sub, 15 pole, male				
Setpoint		two setpoints (SP1, SP2)				
Relay contact	VDC / ADC	≤30 / ≤0.5				
Hysteresis	% F.S.	1				
Diagnostic port Protocol		RS232-C				
Read		pressure, status, ID,				
Set		set points, filter, zero adjust, factory reset, DC offset				
Materials exposed to vacuum		Aluminum oxide ceramic (Al ₂ O ₃), stainless steel (AISI 316L ²⁾), Nickel, sealing glass				

¹⁾ Non-linearity, hysteresis, repeatability at 25°C ambient operating temperature without temperature effects after 2 hours operation.

²⁾ 18% Cr, 10% Ni, 3% Mo, 69% Fe

CDG045 (continued)

Specifications (Torr based other ranges)

Measurement Range F.S. (Full Scale)	Torr Pa mbar	500	200	50	20	5	2	0.5	0.25	
		66,661 666.61	26,664 267	6,666.1 66.67	2,666 26.7	666.61 6.6661	266.66 2.67	66.66 0.67	33.3 0.33	
Accuracy ¹⁾	% of reading	0.15								
Temperature effect on zero	% F.S./°C	0.0025						0.005		
on span	% of reading/°C	0.01								
Pressure, max.	kPa (absolute)	400	260					130		
Resolution	% F.S.	0.003								

Further specifications see table above.

Specifications (mbar based products)

Measurement Range F.S. (Full Scale)	mbar Pa	1100	100	10	1	0.1
		110,000	10,000	1,000	100	10
Accuracy ¹⁾	% of reading	0.15				
Temperature effect on zero	% F.S./°C	0.0025				0.005
on span	% of reading/°C	0.01				
Pressure, max.	kPa (absolute)	400	260			130
Resolution	% F.S.	0.003				

Further specifications see tables «SPECIFICATIONS (Torr based standard products)» and «SPECIFICATIONS (Torr based other products)».

Specifications (DeviceNet™)

CDG045D DeviceNet™		
Protocol		DeviceNet™, group 2 slave only
Data rate	kBaud	125, 250, 500 by switch or network programmable
Cable length		
125 kbps	m (ft)	500 (1650)
250 kbps	m (ft)	250 (825)
500 kbps	m (ft)	100 (330)
MAC ID		address 00 - 63 by switch or network programmable
Digital functions	read set	pressure, status, ID set points, filter, zero adjust, factory reset, DC offset
Specification		DeviceNet™ "Vacuum Gauge Device Profile" (ODVA)
Device type		"VG" vacuum gauge
I / O slave messaging		polling only
Supply voltage for gauge at D-sub connector		+14 ... +30 VDC or ±15 V / ≤12 W
Supply voltage for DeviceNet transceiver at microstyle connector		24 V nom / <2 W (11 ... 25 V)
Connector for DeviceNet™		microstyle, 5 pin
Connector for CDG (analog output, supply voltage CDG, setpoints)		D-sub, 15 pin, male

CDG045 (continued)

Specifications (Profibus DP)

CDG045D Profibus DP

Baud rates	kBaud	9.6 / 19.2 / 93.75 / 187.5 / 500
	MBaud	1.5 / 12
Address		address 00 - 125 by switch or network programmable
Digital functions	read	pressure, status, ID
	set	set points, filter, zero adjust, factory reset, DC offset
Connector for Profibus DP		D-sub, 9 pin, female
Connector for CDG (analog output, supply voltage, setpoints)		D-sub, 15 pin, male

Dimensions

mm (inch)

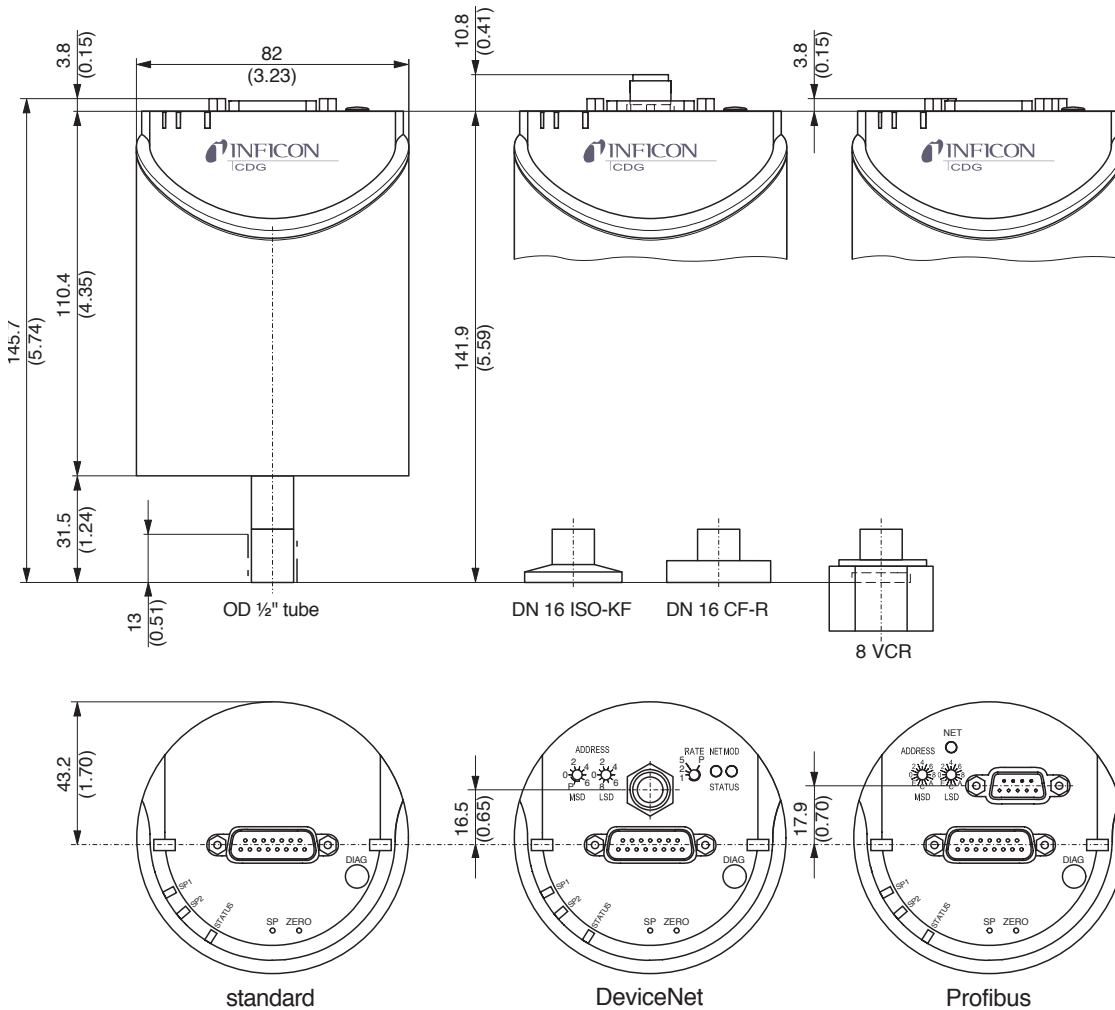

		1/2" tube	DN 16 ISO KF	DN 16 CF-R	8 VCR®
Internal volume	cm ³ (inch ³)	4.2 (0.26)	4.2 (0.26)	4.2 (0.26)	4.2 (0.26)
Weight	g	837	852	875	897

SKY® Capacitance Diaphragm Gauges

CDG100D

INFICON SKY CDG100D manometers are your best choice for accurate total pressure measurement and control. CDG100D gauges are temperature controlled at 100°C for superior performance in demanding semiconductor and plasma processes. They are available for full scale ranges from 100 mTorr to 1000 Torr, with all common flange types and fieldbus interfaces and provide a linear 0 to 10 V, gas type independent, pressure signal. INFICON capacitance manometers use an ultra pure alumina ceramic diaphragm which is corrosion proof. The advantages of the ceramic sensor are better signal stability, faster recovery from atmosphere, short warm up time and an extraordinary lifetime. INFICON CDG are high quality, cost effective pressure sensors for demanding semiconductor, plasma and vacuum applications.



Advantages

- Lower CoO (cost of ownership), 50% faster warm up, energy efficient low power consumption
- Easy integration, wide variety of full scales, flanges and interfaces, standard with two set points
- Easy one push button or remote signal zero command, zero offset adjustable
- Diagnostic port for quick service and maintenance
- Two year warranty, longer lifetime with advanced heating concept and gauge protection
- No long term recalibration due to excellent signal stability and repeatability, even in harsh plasma applications
- Compliance & standards: CE, EN, UL, SEMI, RoHS

Applications

- Etch, PVD, CVD and other semiconductor production processes
- Chemical and corrosive high temperature processes
- General thin film and vacuum processes requiring gauge protection

CDG100D (continued)

Ordering Information

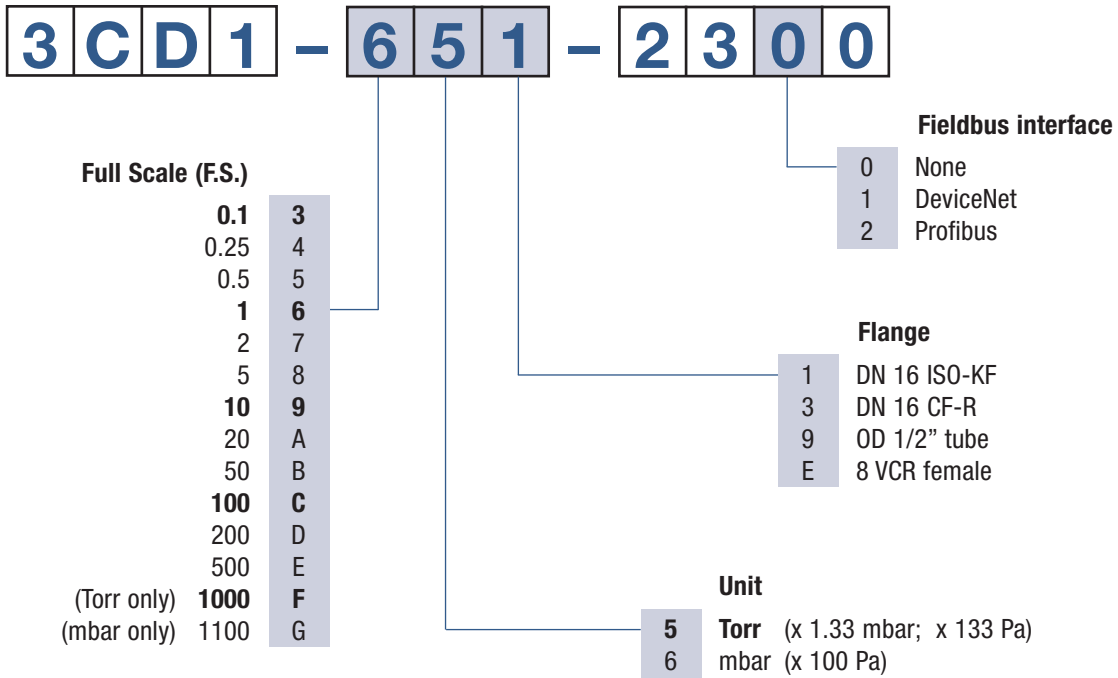

bold = standard products

Other flange types and full scale ranges (F.S.) on request.

Accessories

	Diagnostic
Communication adapter (2 m) for PC RS232 serial port	303-333

Software to run the diagnostic functions on Windows NT, XP can be downloaded from our website.

CDG100D (continued)

Specifications (Torr based standard products)

Measurement Range F.S. (Full Scale)	Torr Pa mbar	1000 133,322 1333	100 13,332 133	10 1,333 13.3	1 133 1.3	0.1 13 0.13
Accuracy ¹⁾	% of reading	0.2				0.4
Temperature effect on zero	% F.S./°C	0.0025				0.005
on span	% of reading/°C	0.02				
Pressure, max.	kPa (absolute)	400	260			130
Resolution	% F.S.	0.003				
Lowest reading	% F.S.	0.01				
Lowest suggested reading	% F.S.	0.05				
Lowest suggested control pressure	% F.S.	0.5				
Temperature Operation (ambient)	°C	+10 ... +50				
Bakeout at flange	°C	≤110				
Storage	°C	-40 ... +65				
Supply voltage		+14 ... +30 VDC or ±15 V (±5%)				
Power consumption During Heat up	W	≤15				
At operating temperature	W	≤10				
Output signal (analog)	VDC	0 ... +10				
Response time	ms	30				130
Degree of protection		IP 40				
Standards		EN 61000-6-2, EN 61010, UL 61010-1, CSA 22.2 No.61010-1, SEMI S-2				
Electrical connection		D-sub, 15 pole, male				
Setpoint		two setpoints (SP1, SP2)				
Relay contact	VDC / ADC	≤30 / ≤0.5				
Hysteresis	% F.S.	1				
Diagnostic port Protocol		RS232-C				
Read		pressure, status, ID,				
Set		set points, filter, zero adjust, factory reset, DC offset				
Materials exposed to vacuum		Aluminum oxide ceramic (Al ₂ O ₃), stainless steel (AISI 316L ²⁾ , Nickel, sealing glass				

¹⁾ Non-linearity, hysteresis, repeatability at 25°C ambient operating temperature without temperature effects after 2 hours operation.

²⁾ 18% Cr, 10% Ni, 3% Mo, 69% Fe

Specifications (Torr based other ranges)

Measurement Range F.S. (Full Scale)	Torr Pa mbar	500 66,661 666.61	200 26,664 267	50 6,666.1 66.67	20 2,666 26.7	5 666.61 6.6661	2 266.66 2.67	0.5 66.66 0.67	0.25 33.3 0.33
Accuracy ¹⁾	% of reading	0.2						0.4	
Temperature effect on zero	% F.S./°C	0.0025						0.005	
on span	% of reading/°C	0.02							
Pressure, max.	kPa (absolute)	400	260			130			
Resolution	% F.S.	0.003							

Further specifications see table above.

CDG100D (continued)

Specifications (mbar based products)

Measurement Range F.S. (Full Scale)	mbar Pa	1100 110,000	100 10,000	10 1,000	1 100	0.1 10
Accuracy ¹⁾	% of reading			0.2		0.4
Temperature effect on zero	% F.S./°C		0.0025			0.005
on span	% of reading/°C			0.02		
Pressure, max.	kPa (absolute)	400		260		130
Resolution	% F.S.			0.003		

Further specifications see table «SPECIFICATIONS (Torr based standard products)».

Specifications (DeviceNet™)

			CDG100D DeviceNet™
Protocol			DeviceNet™, group 2 slave only
Data rate	kBaud		125, 250, 500 by switch or network programmable
Cable length			
125 kbps	m (ft)		500 (1650)
250 kbps	m (ft)		250 (825)
500 kbps	m (ft)		100 (330)
MAC ID			address 00 - 63 by switch or network programmable
Digital functions	read		pressure, status, ID
	set		set points, filter, zero adjust, factory reset, DC offset
Specification			DeviceNet™ "Vacuum Gauge Device Profile" (ODVA)
Device type			"VG" vacuum gauge
I / O slave messaging			polling only
Supply voltage for gauge at D-sub connector			+14 ... +30 VDC or ±15 V / ≤12 W
Supply voltage for DeviceNet transceiver at microstyle connector			24 V nom / <2 W (11 ... 25 V)
Connector for DeviceNet™			microstyle, 5 pin
Connector for CDG (analog output, supply voltage CDG, setpoints)			D-sub, 15 pin, male

Specifications (Profibus DP)

			CDG100D Profibus DP
Baud rates	kBaud		9.6 / 19.2 / 93.75 / 187.5 / 500
	MBaud		1.5 / 12
Address			address 00 - 125 by switch or network programmable
Digital functions	read		pressure, status, ID
	set		set points, filter, zero adjust, factory reset, DC offset
Connector for Profibus DP			D-sub, 9 pin, female
Connector for CDG (analog output, supply voltage, setpoints)			D-sub, 15 pin, male

CDG100D (continued)

Dimensions

mm (inch)

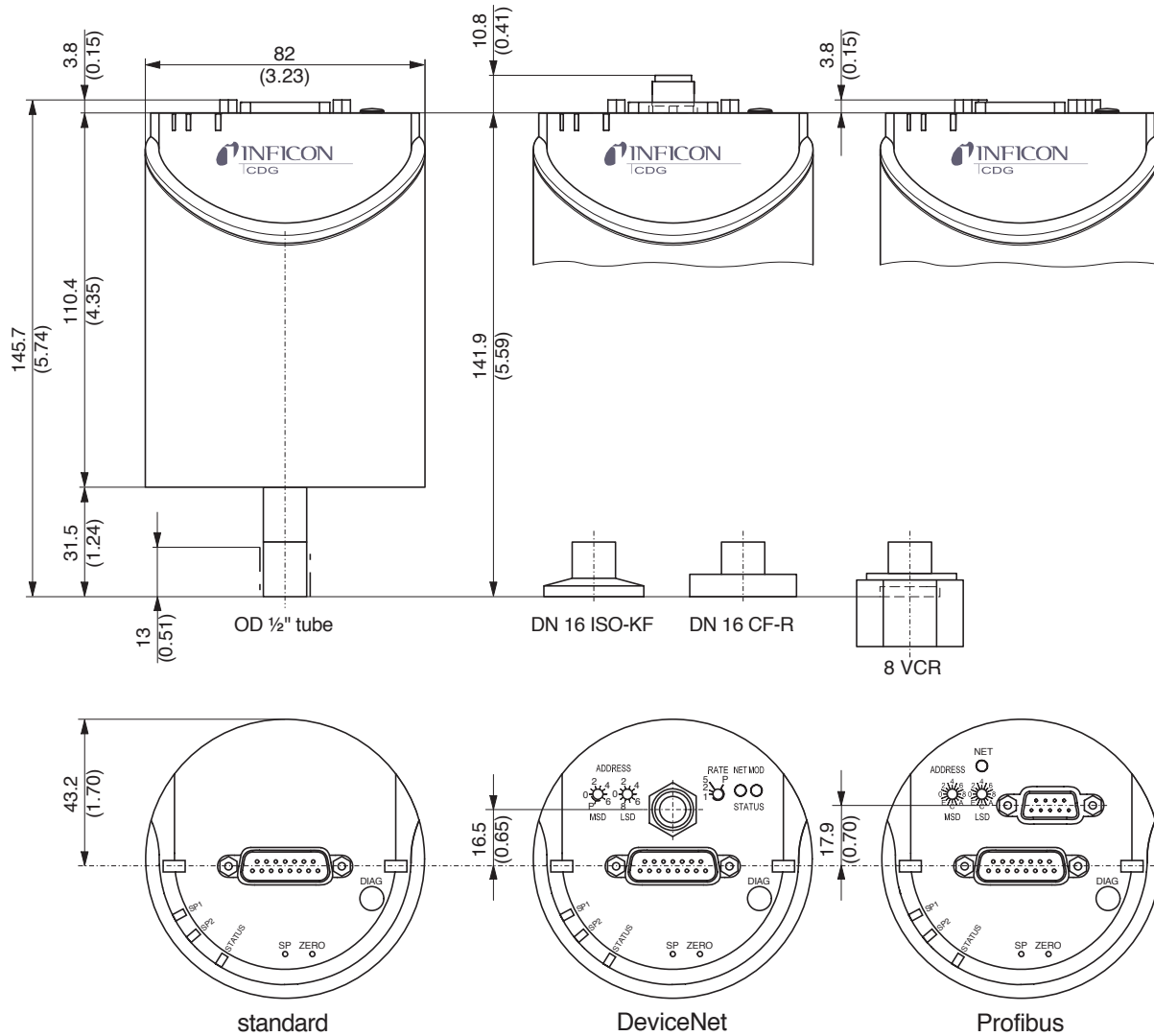

		1/2" tube	DN 16 ISO KF	DN 16 CF-R	8 VCR®
Internal volume	cm ³ (inch ³)	4.2 (0.26)	4.2 (0.26)	4.2 (0.26)	4.2 (0.26)
Weight	g	837	852	875	897

SKY® Capacitance Diaphragm Gauges

CDG160D, CDG200D

INFICON SKY CDG160D and CDG200D high temperature manometers are your best choice for accurate total pressure measurement and control. CDG160D and CDG200D gauges are temperature controlled at 160°C respectively 200°C for superior performance in demanding semiconductor and plasma processes. They are available for full scale ranges from 1 Torr to 1000 Torr, with all common flange types and fieldbus interfaces and provide a linear 0 to 10V, gas type independent, pressure signal. INFICON capacitance manometers use an ultra pure alumina ceramic diaphragm which is corrosion proof. The advantages of the ceramic sensor are better signal stability, faster recovery from atmosphere, short warm up time and an extraordinary lifetime. INFICON CDG are high quality, cost effective pressure sensors for demanding semiconductor, plasma and vacuum applications.

Advantages

- Lower CoO (cost of ownership), 50% faster warm up, energy efficient low power consumption
- Easy integration, wide variety of full scales, flanges and interfaces, standard with two set points
- Easy one push button or remote signal zero command, zero offset adjustable
- Diagnostic port for quick service and maintenance
- Two year warranty, longer lifetime with  heating concept and gauge protection
- No long term recalibration due to excellent signal stability and repeatability, even in harsh plasma applications
- Compliance & standards: CE, EN, UL, SEMI, RoHS

Applications

- Etch, PVD, CVD, LPCVD and other semiconductor production processes
- Chemical and corrosive high temperature processes
- General thin film and vacuum processes requiring gauge protection



New!
200°C sensor

CDG160D, CDG200D (continued)

Ordering Information

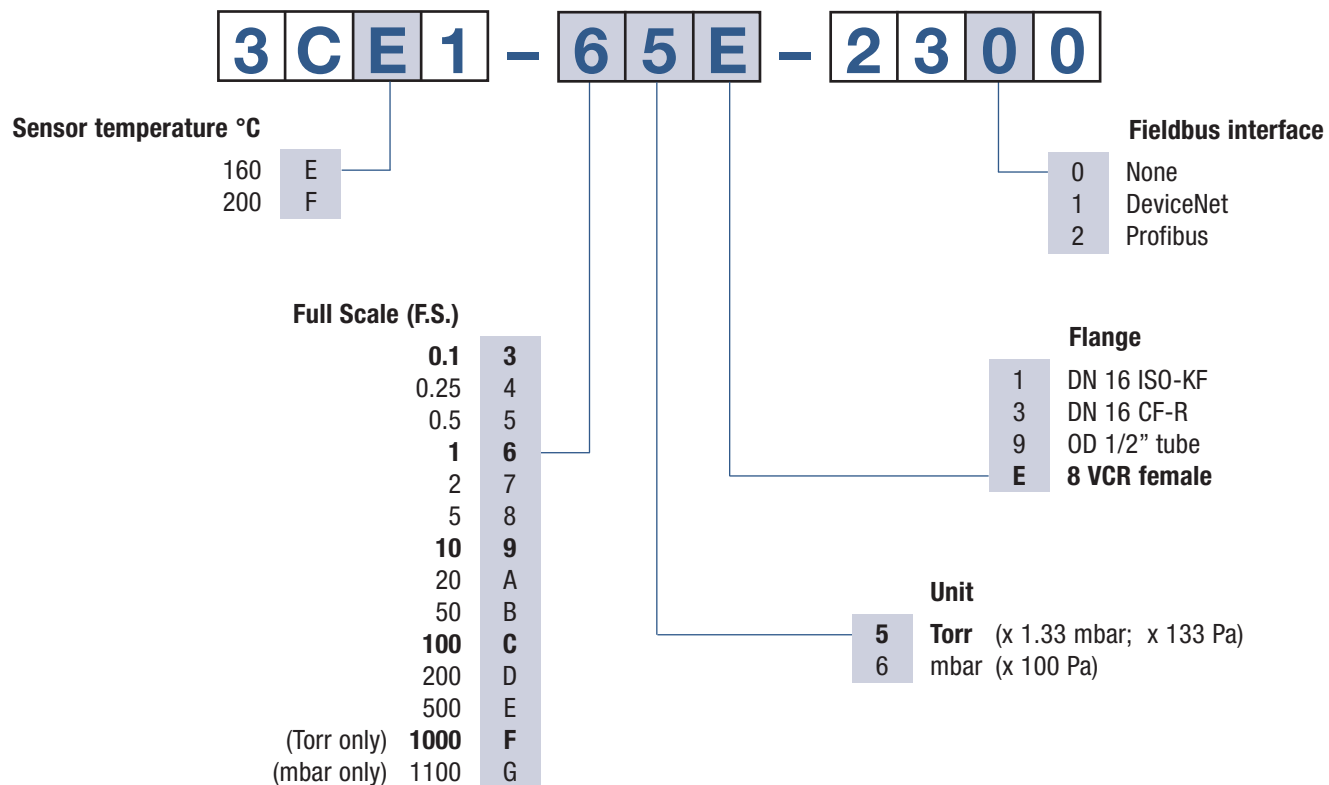

bold = standard products

Other flange types and full scale ranges (F.S.) on request.

Accessories

	Diagnostic
Communication adapter (2 m) for PC RS232 serial port	303-333

Software to run the diagnostic functions on Windows NT, XP can be downloaded from our website.

CDG160D, CDG200D (continued)

Specifications (Torr based standard products)

Measurement Range F.S. (Full Scale)	Torr Pa mbar	1000 133,322 1333	100 13,332 133	10 1,333 13.3	1 133 1.3
Accuracy ¹⁾	% of reading	0.4			
Temperature effect					
on zero	% F.S./°C	0.005			
on span	% of reading/°C	0.02			
Pressure, max.	kPa (absolute)	400	260		
Resolution	% F.S.	0.003			
Lowest reading	% F.S.	0.01			
Lowest suggested reading	% F.S.	0.05			
Lowest suggested control pressure	% F.S.	0.5			
Temperature					
Operation (ambient)	°C	+10 ... +50			
Bakeout at flange	°C	≤200			
Storage	°C	-40 ... +65			
Supply voltage		+21 ... +30 VDC or ±15 V (±5%)			
Power consumption during heat up					
CDG160D	W	≤18			
CDG200D	W	≤25			
Power consumption at operating temperature					
CDG160D	W	≤12			
CDG200D	W	≤18			
Output signal (analog)	VDC	0 ... +10			
Response time	ms	30			
Degree of protection		IP 40			
Standards		EN 61000-6-2, EN 61010, UL 61010-1, CSA 22.2 No.61010-1, SEMI S-2			
Electrical connection		D-sub, 15 pole, male			
Setpoint		two setpoints (SP1, SP2)			
Relay contact	VDC / ADC	≤30 / ≤0.5			
Hysteresis	% F.S.	1			
Diagnostic port					
Protocol		RS232-C			
Read		pressure, status, ID,			
Set		set points, filter, zero adjust, factory reset, DC offset			
Materials exposed to vacuum		Aluminum oxide ceramic (Al ₂ O ₃), stainless steel (AISI 316L ²⁾ , Nickel, sealing glass			

¹⁾ Non-linearity, hysteresis, repeatability at 25°C ambient operating temperature without temperature effects after 2 hours operation.

²⁾ 18% Cr, 10% Ni, 3% Mo, 69% Fe

CDG160D, CDG200D (continued)

Specifications (Torr based other ranges)

Measurement Range F.S. (Full Scale)	Torr Pa mbar	500	200	50	20	5	2
		66,661 666.61	26,664 267	6,666.1 66.67	2,666 26.7	666.61 6.6661	266.66 2.67
Accuracy ¹⁾	% of reading	0.4					
Temperature effect on zero	% F.S./°C	0.005					
on span	% of reading/°C	0.02					
Pressure, max.	kPa (absolute)	400	260				
Resolution	% F.S.	0.003					

Further specifications see table above.

Specifications (mbar based products)

Measurement Range F.S. (Full Scale)	mbar Pa	1100	100	10	1
		110,000	10,000	1,000	100
Accuracy ¹⁾	% of reading	0.4			
Temperature effect on zero	% F.S./°C	0.005			
on span	% of reading/°C	0.02			
Pressure, max.	kPa (absolute)	400	260		
Resolution	% F.S.	0.003			

Further specifications see table «SPECIFICATIONS (Torr based standard products)».

Specifications (DeviceNet™)

CDG160D, CDG200D DeviceNet™		
Protocol	DeviceNet™, group 2 slave only	
Data rate	kBaud	125, 250, 500 by switch or network programmable
Cable length		
125 kbps	m (ft)	500 (1650)
250 kbps	m (ft)	250 (825)
500 kbps	m (ft)	100 (330)
MAC ID	address 00 - 63 by switch or network programmable	
Digital functions	read	pressure, status, ID
	set	set points, filter, zero adjust, factory reset, DC offset
Specification	DeviceNet™ "Vacuum Gauge Device Profile" (ODVA)	
Device type	"VG" vacuum gauge	
I / O slave messaging	polling only	
Supply voltage for gauge at D-sub connector	+14 ... +30 VDC or ±15 V / ≤12 W	
Supply voltage for DeviceNet transceiver at microstyle connector	24 V nom / <2 W (11 ... 25 V)	
Connector for DeviceNet™	microstyle, 5 pin	
Connector for CDG (analog output, supply voltage CDG, setpoints)	D-sub, 15 pin, male	

CDG160D, CDG200D (continued)

Specifications (Profibus DP)

		CDG160D, CDG200D Profibus DP	
Baud rates	kBaud	9.6 / 19.2 / 93.75 / 187.5 / 500	
	MBaud	1.5 / 12	
Address		address 00 - 125 by switch or network programmable	
Digital functions	read	pressure, status, ID	
	set	set points, filter, zero adjust, factory reset, DC offset	
Connector for Profibus DP		D-sub, 9 pin, female	
Connector for CDG (analog output, supply voltage, setpoints)		D-sub, 15 pin, male	

Dimensions, Internal Volume, Weight

mm (inch)

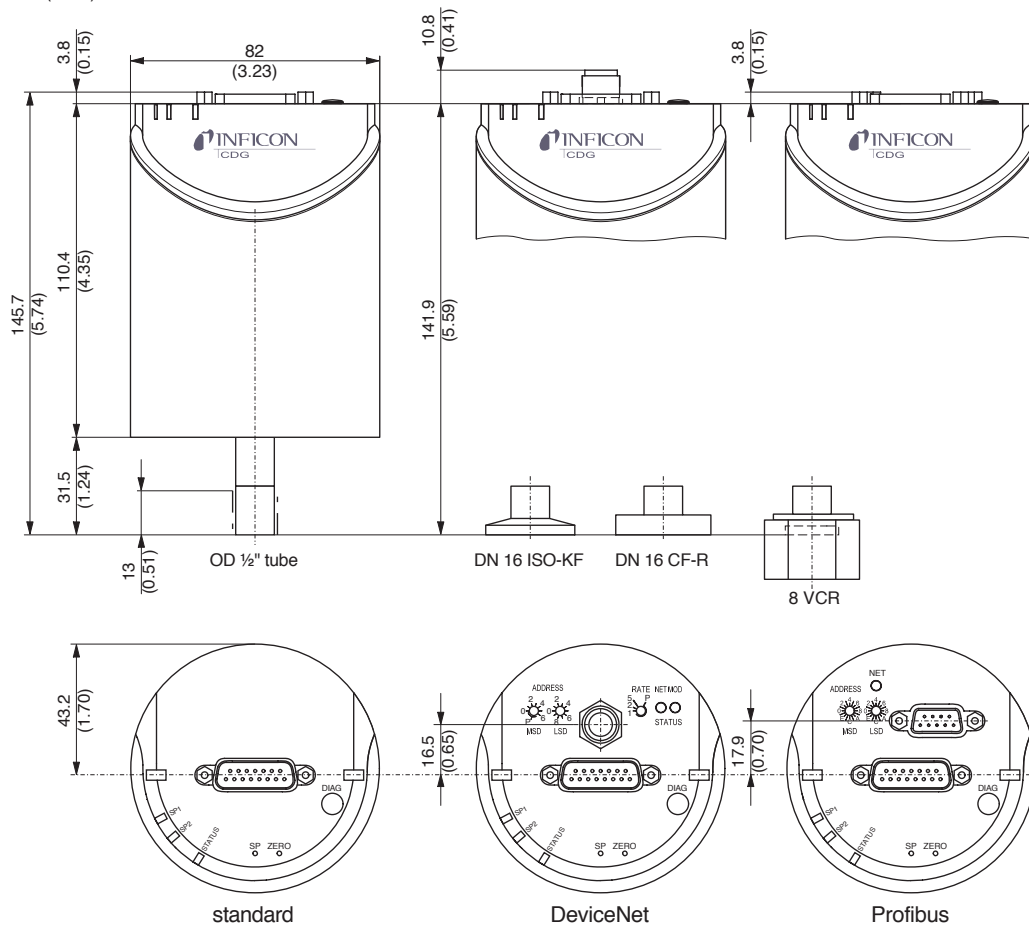

		1/2" tube	DN 16 ISO KF	DN 16 CF-R	8 VCR®
Internal volume	cm ³ (inch ³)	4.2 (0.26)	4.2 (0.26)	4.2 (0.26)	4.2 (0.26)
Weight	g	837	852	875	897

SKY® Capacitance Diaphragm Gauges

AllCeramic™ CDG025-C

All vacuum exposed surfaces of the Sky AllCeramic CDG are constructed of ultra-pure aluminum oxide ceramic, replacing the stainless steel tubing of our traditional CDG. This product is preferred in applications where metal contamination must be avoided.



Advantages

- No metal contamination
- Marginal zero drift
- Virtually corrosion proof – long sensor life results in reduced downtime thus reducing cost of ownership
- Superior accuracy and repeatability over long period of operation
- Better long term and temperature stability
- Less sensitive to frequent pressure cycles to atmosphere, may eliminate isolation valve (depending on operation mode)
- Less susceptible to particles and process by-products due to protection shield (Suprashield)

Applications

- Etch, CVD and PVD processes
- Doping silicon using implantation or diffusion processes
- Oxidation
- Creation of gate oxide layer in the range of 100 Å
- Creation of barrier layers (Ti, TiN, Ta and TaN as a protection layer between Silicon and Aluminum or Copper)

Ordering Information

Type	Flange	Full scale (Pa ¹⁾)				
		133322	13332.2	1333.22	133.322	ATM±13332.2 ²⁾
CDG025-C	1/2" tube	371-250	371-251	371-252	371-253	371-200

¹⁾ Other pressure units on request

²⁾ Pressure difference between atmospheric and gauge pressure

AllCeramic CDG025-C (continued)

Specifications

Measurement Range F.S. (full scale)	Pa	133322	13332.2	1333.22	133.322	ATM±13332.2
Lowest suggested control pressure	Pa	$6.66 \times 10^{+2}$	$6.66 \times 10^{+1}$	$6.66 \times 10^{+0}$	6.66×10^{-1}	–
Lowest suggested reading	Pa	$6.66 \times 10^{+1}$	$6.66 \times 10^{+0}$	6.66×10^{-1}	6.66×10^{-2}	–
Lowest reading	Pa	$1.33 \times 10^{+1}$	$1.33 \times 10^{+0}$	1.33×10^{-1}	1.33×10^{-2}	–
Accuracy ¹⁾	% of reading	0.2	0.2	0.2	0.2	0.2
Temperature effect on zero	% F.S./°C	0.005	0.005	0.005	0.015	0.05
	% of reading/°C	0.01	0.01	0.01	0.01	0.04
Resolution	% F.S.	0.0015	0.0015	0.0015	0.0025	0.01
Temperature Operation (ambient) At flange Storage	°C	+5 ... +50	+5 ... +50	+5 ... +50	+5 ... +50	+5 ... +50
	°C	≤110	≤110	≤110	≤110	≤110
	°C	–40 ... +65	–40 ... +65	–40 ... +65	–40 ... +65	–40 ... +65
Pressure max. (absolute)	kPa	400	267	267	267	267
Power supply Voltage 1 Voltage 2 Power consumption ²⁾	VDC	±15 ±5%	±15 ±5%	±15 ±5%	±15 ±5%	±15 ±5%
	VDC	+18 ... +26.4	+18 ... +26.4	+18 ... +26.4	+18 ... +26.4	+18 ... +26.4
	W	≤1.6	≤1.6	≤1.6	≤1.6	≤1.6
Output signal (analog) Measuring range Voltage range Relation voltage vs. pressure	V	0 ... +10	0 ... +10	0 ... +10	0 ... +10	+5±5
	V	–11 ... +11	–11 ... +11	–11 ... +11	–11 ... +11	–11 ... +11
		linear	linear	linear	linear	linear
Response time	ms	30	30	30	100	30
Internal volume	cm ³ (inch ³)	4.5 (0.275)	4.5 (0.275)	4.5 (0.275)	4.5 (0.275)	4.5 (0.275)
Weight	g	250	250	250	250	250
Protective type		IP 30	IP 30	IP 30	IP 30	IP 30
Electrical connection		D-sub, 15 pole, male	D-sub, 15 pole, male	D-sub, 15 pole, male	D-sub, 15 pole, male	D-sub, 15 pole, male
Materials exposed to vacuum	Aluminum oxide ceramic (Al ₂ O ₃), sealing glass					

¹⁾ Non-linearity, hysteresis, repeatability at 25°C ambient operating temperature without temperature effects after 2 hours operation.

²⁾ Typical value at 25°C ambient temperature after reaching operating temperature.

Dimensions

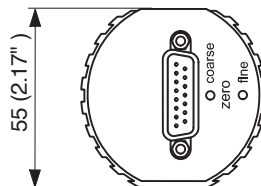
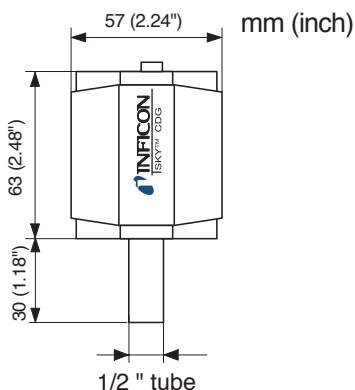

SKY® Capacitance Diaphragm Gauges

AllCeramic™ CDG160A-C / CDG160A-CS

The INFICON SKY AllCeramic CDG160A-C is the only completely metal-free 160°C temperature controlled capacitance diaphragm gauge designed for demanding applications, such as oxidation, diffusion and LPCVD. All surfaces exposed to the vacuum such as tubing, plasma shield and contamination protection shield are composed of corrosion-resistant ultra pure aluminum oxide ceramic, eliminating potential metal contamination from the gauge.

The INFICON SKY AllCeramic CDG160A-C integrates the proven sensor technology of the INFICON CDG160A series of gauges for reliable and repeatable performance in LPCVD and other harsh semiconductor manufacturing applications.



Advantages

- Metal-free ultra pure ceramic design prevents metal contaminations
- Temperature controlled to 160°C prevents condensation of process products and by-products
- Compact design saves valuable space and simplifies tool integration
- High ambient temperature compatibility
- Enhanced particle protection chamber with an additional protection shield (Suprashield) reduces the probability of gauge contamination
- Unique ceramic sensor design provides repeatability and accurate measurements with excellent long-term stability
- Optional set point and status indication provides additional control and safety functions

Applications

- Oxidation, diffusion and LPCVD processes
- Other metal-free vacuum measurement requirements

Ordering Information

Type	Set point	Flange	Full scale (Pa ¹⁾)			
			133322	13332.2	1333.22	133.322
CDG160A-C	none	1/2" tube	371-260	371-261	371-262	371-263
CDG160A-CS	2	1/2" tube	371-270	371-271	371-272	371-273

¹⁾ Other pressure units on request

CDG160A-C / CDG160A-CS (continued)

Specifications

Measurement Range F.S. (full scale)	Pa	133322	13332.2	1333.22	133.322
Lowest suggested control pressure	Pa	$6.66 \times 10^{+2}$	$6.66 \times 10^{+1}$	$6.66 \times 10^{+0}$	6.66×10^{-1}
Lowest suggested reading	Pa	$6.66 \times 10^{+1}$	$6.66 \times 10^{+0}$	6.66×10^{-1}	6.66×10^{-2}
Lowest reading	Pa	$1.33 \times 10^{+1}$	$1.33 \times 10^{+0}$	1.33×10^{-1}	1.33×10^{-2}
Accuracy ¹⁾	% of reading	0.5	0.5	0.5	0.5
Temperature effect on zero	% F.S./°C	0.005	0.005	0.005	0.005
on span	% of reading/°C	0.02	0.02	0.02	0.02
Resolution	% F.S.	0.005	0.005	0.005	0.005
Temperature Operation (ambient)	°C	+15 ... +55	+15 ... +55	+15 ... +55	+15 ... +55
Bakeout (at flange)	°C	≤160	≤160	≤160	≤160
Storage	°C	-40 ... +65	-40 ... +65	-40 ... +65	-40 ... +65
Pressure max. (absolute)	kPa	400	267	267	267
Power supply	VDC	±15 ±5%	±15 ±5%	±15 ±5%	±15 ±5%
Power consumption at operating temperature	W	≤15	≤15	≤15	≤15
during warm up					
CDG160A-C	W	≤24	≤24	≤24	≤24
CDG160A-CS	W	≤27	≤27	≤27	≤27
Output signal (analog) Measuring range	V	0 ... +10	0 ... +10	0 ... +10	0 ... +10
Voltage range	V	-11 ... +11	-11 ... +11	-11 ... +11	-11 ... +11
Relation voltage vs. pressure		linear	linear	linear	linear
Response time	ms	50	50	50	50
Protective type		IP 30	IP 30	IP 30	IP 30
Electrical connection CDG160A-C		D-sub, 15 pole, male	D-sub, 15 pole, male	D-sub, 15 pole, male	D-sub, 15 pole, male
CDG160A-CS		D-sub, 25 pole, male	D-sub, 25 pole, male	D-sub, 25 pole, male	D-sub, 25 pole, male
Internal volume	cm ³ (inch ³)	4.7 (0.286)	4.7 (0.286)	4.7 (0.286)	4.7 (0.286)
Weight CDG160A-C	g	460	460	460	460
CDG160A-CS	g	490	490	490	490
Materials exposed to vacuum	Aluminum oxide ceramic (Al ₂ O ₃), sealing glass				

CDG160A-CS

Relay functions	two set points, five status indicators (two setpoints active, temperature sensor ok, temperature ready, overheat) and optical status indicator (power on)				
Relays type of contact		NO / NC change over	NO / NC change over	NO / NC change over	NO / NC change over
Switching voltage max.	VDC / VAC	110 / 125	110 / 125	110 / 125	110 / 125
Switching current	A	1	1	1	1

¹⁾ Non-linearity, hysteresis, repeatability at 25°C ambient operating temperature without temperature effects after 2 hours operation.

CDG160A-C / CDG160A-CS (continued)

Dimensions

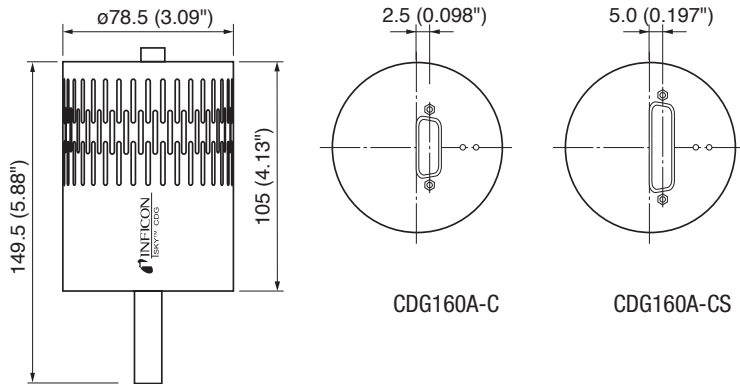

Ceramic tube 1/2"
CDG160A-C and CDG160A-CS

Bayard-Alpert Pirani Gauge

BPG400

The INFICON Bayard-Alpert Pirani Combination Gauge, BPG400, functions as two gauges in a single compact unit measuring from 5×10^{-10} mbar to atmosphere (3.8×10^{-10} Torr to atmosphere). Combining technologies reduces the complexity of installation, setup, and integration. Choose the BPG400 for affordable and repeatable process to base pressure measurements in one economic package.

ADVANTAGES

- Extremely wide measurement range from 5×10^{-10} mbar to atmosphere (3.8×10^{-10} Torr to atmosphere)
- Excellent repeatability in the process pressure range from 10^{-8} ... 10^{-2} mbar of 5%
- The Pirani interlock protects the Bayard-Alpert system from premature filament burnout and excess contamination from high pressure operation
- Long-life yttrium oxide coated iridium filament
- Optional graphic display and Fieldbus interfaces available
- Automatic high vacuum Pirani adjustment reduces operator interventions

APPLICATIONS

- Pressure measurement in semiconductor process and transfer chambers
- Industrial coating
- General vacuum measurement and control in the low to ultra high vacuum range



Ordering Information

Type	BPG400 without LCD display	BPG400 with LCD display	BPG400-SP with Profibus DP	BPG400-SD with DeviceNet™	BPG400-SR with RS485
DN 25 ISO-KF	353-500	353-501	353-505	353-507	353-509
DN 40 CF-R	353-502	353-503	353-506	353-508	353-513
Replacement sensor 25 ISO-KF	354-490	354-490	354-490	354-490	354-490
Replacement sensor 40 CF-R	354-491	354-491	354-491	354-491	354-491

ACCESSORIES

Power supply 24 V DC / RS232C line	353-511
Bakeout extension, 100 mm (3.94 inch)	353-510
Baffle	353-512

BPG400 (continued)

Specifications

		BPG400 Standard	BPG400 Display
Measurement range	(air, O ₂ , CO, N ₂)	mbar (Torr)	5 x 10 ⁻¹⁰ ... 1000 (3.8 x 10 ⁻¹⁰ ... 750)
Accuracy	10 ⁻⁸ ... 10 ⁻² mbar	% of reading	±15
Repeatability	10 ⁻⁸ ... 10 ⁻² mbar	% of reading	5
Degas ¹⁾	p < 7.2 x 10 ⁻⁶	mbar	electron bombardment, max. 3 min
Pressure, max.		bar (absolute)	2
Temperature			
Operation (ambient)		°C	0 ... +50
Storage		°C	-20 ... +70
Bakeout			
At flange with extension		°C	150
At flange without extension		°C	80
Electronics removed		°C	150
Supply voltage		V / A DC	20 ... 28 / 0.8
Output signal analog		V	0 ... +10
Measurement range		V	0.774 ... 10
Voltage vs. pressure		V / Decade	0.75
Error signal		V	0.3 / 0.5
Load impedance, min.		k	10
Interface (digital) ²⁾			RS232C
Electrical connection			D-sub, 15 pin, male
Cable length, max. ³⁾		m (ft)	100 (330)
Materials exposed to vacuum			Yt ₂ O ₃ , Ir, Pt, Mo, Cu, W, NiFe, NiCr, stainless steel, glass
Internal volume KF / CF		cm ³ (inch) ³	24 (1.46) / 34 (2.1)
Weight KF / CF		g	285 / 550
Protection type			IP30

¹⁾ Reduced accuracy during degas

²⁾ Simultaneous use of RS232C or VGC400 series controllers and Fieldbus is not allowed

³⁾ For RS232C operation <30 m

Specifications

		BPG400-SP Profibus DP
Baud rates	kBaud	9.6 / 19.2 / 93.75 / 187.5 / 500
	MBaud	1.5 / 12
Address		2 switches (address 00 - 127) or network programmable
Digital functions		read pressure, select units: Torr, mbar, Pa degas function, Pirani full scale adjust monitor gauge status safe state allows definition of behavior in case of error detailed alarm and warning information
Analog functions		0 ... 10 V analog output pressure indication two setpoint relays A + B
Setpoint relays		2
Range	mbar	1 x 10 ⁻⁹ ... 100
Relay contact		n.o., potential free
Hysteresis	% of reading	10
Contact rating	V / A DC	60 / 0.5
Connector for Profibus DP		D-sub, 9 pin, female
Connector for BPG (analog output, supply voltage, setpoints)		D-sub, 15 pin, male

BPG400 (continued)

Specifications

		BPG400-SD DeviceNet™
Protocol		DeviceNet™, group 2 slave only
Data rate switch	kBaud	125, 250, 500 or network programmable
Cable length		
125 kbps	m (ft)	500 (1650)
250 kbps	m (ft)	250 (825)
500 kbps	m (ft)	100 (330)
MAC ID		2 switches (address 00 - 63) or network programmable
Digital functions		read pressure, select units: Torr, mbar, Pa degas function, Pirani full scale adjust monitor gauge status safe state allows definition of behavior in case of error detailed alarm and warning information
Analog functions		0 ... 10 V analog output pressure indication two setpoint relays A + B
Specification		DeviceNet™ "Vacuum Gauge Device Profile"
Device type		"CG" for combination gauge
I / O slave messaging		polling only
Setpoint relays		2
Range	mbar	1 x 10 ⁻⁹ ... 100
Relay contact		n.o., potential free
Hysteresis	% of reading	10
Contact rating	V / A DC	60 / 0.5
Supply voltage for DeviceNet™	V / A DC	11 ... 25 / 0.5
Supply voltage for gauge	V / A DC	20 ... 28 / 0.8
Connector for DeviceNet™		microstyle, 5 pin
Connector for BPG (analog output, supply voltage, setpoints)		D-sub, 15 pin, male

Specifications

		BPG400-SR RS485
Baud rates	kBaud	0.3 / 1.2 / 2.4 / 4.8 / 9.6 / 19.2 / 28.8
Address		2 switches (address 00 - 127) or network programmable
Digital functions		read pressure, select units: Torr, mbar, Pa degas function, Pirani full scale adjust monitor gauge status detailed alarm and warning information
Analog functions		0 ... 10 V analog output pressure indication two setpoint relays A + B
Setpoint relays		2
Range	mbar	1 x 10 ⁻⁹ ... 100
Relay contact		n.o., potential free
Hysteresis	% of reading	10
Contact rating	V / A DC	60 / 0.5
Connector for RS485		D-sub, 9 pin, male
Connector for BPG (analog output, supply voltage, setpoints)		D-sub, 15 pin, male

BPG400 (continued)

Dimensions

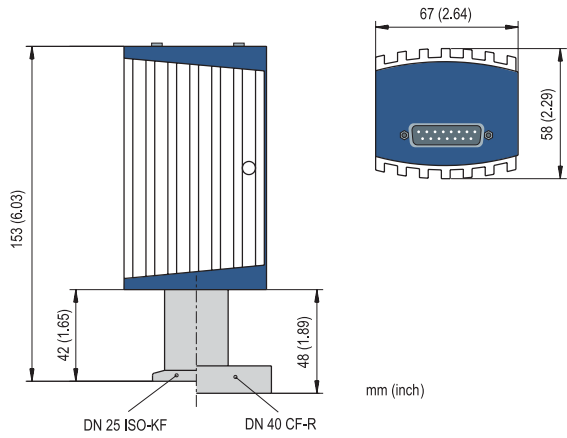

Accessories

Power supply 24 V DC / RS232C line

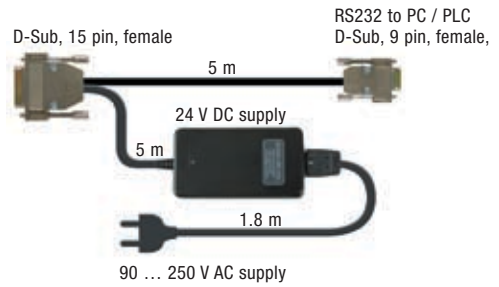

Bakeout extension:

Allows measurement at flange temperatures up to 150°C.
Fast and easy installation.



Baffle:

Prevents contamination of the sensor.
Easy installation into the vacuum connection - no tools required.

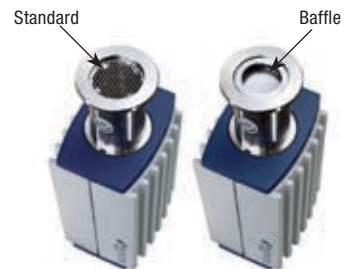

Bayard–Alpert Pirani Gauge

BPG402–S

The INFICON Bayard-Alpert Pirani Combination Gauge, BPG402-S, functions as two gauges in a single compact unit measuring from 5×10^{-10} mbar to atmosphere (3.8×10^{-10} Torr to atmosphere). Combining technologies reduces the complexity of installation, setup, and integration. Choose the BPG402-S with dual yttrium oxide coated iridium filaments for affordable and repeatable process to base pressure measurements in one economical package. Sensing elements with on-board calibration data guarantees high reproducibility when exchanging sensors.

Advantages

- Extremely wide measurement range from 5×10^{-10} mbar to atmosphere (3.8×10^{-10} Torr to atmosphere)
- Excellent repeatability in the process pressure range from 10^{-8} ... 10^{-2} mbar of 5%
- Pirani interlock protects the filament from premature burnout
- Dual long-life yttrium oxide coated iridium filament
- Optional graphic display and Fieldbus interfaces available
- Automatic high vacuum Pirani adjustment reduces operator interventions
- Easy to exchange sensing element with on-board calibration data guarantees high reproducibility

Applications

- Pressure measurement in semiconductor process and transfer chambers
- Industrial coating
- General vacuum measurement and control in the low to ultra high vacuum range

Ordering Information

Type	BPG402-S without display	BPG402-S with display	BPG402-SP with Profibus DP	BPG402-SD with DeviceNet™
DN 25 ISO-KF	353-570	353-572	353-574	353-576
DN 40 CF-R	353-571	353-573	353-575	353-577
Replacement sensor 25 ISO-KF	354-494			
Replacement sensor 40 CF-R	354-495			

Accessories

Power supply 24 V DC / RS232C line	353-511
Baffle	353-512



BPG402-S (continued)

Specifications

		BPG402-S Standard	BPG402-S Display
Measurement range	(air, O ₂ , CO, N ₂)	mbar (Torr)	5 x 10 ⁻¹⁰ ... 1000 (3.8 x 10 ⁻¹⁰ ... 750)
Accuracy	10 ⁻⁸ ... 10 ⁻² mbar	% of reading	±15
Repeatability	10 ⁻⁸ ... 10 ⁻² mbar	% of reading	5
Degas ¹⁾	p < 7.2 x 10 ⁻⁶	mbar	electron bombardment, max. 3 min
Pressure, max.		bar (absolute)	2
Temperature			
Operation (ambient)		°C	0 ... +50
Storage		°C	-20 ... +70
Bakeout at flange without electronics		°C	80
Supply voltage		V / A DC	20 ... 28 / 0.8
Output signal analog		V	0 ... +10
Measurement range		V	0.774 ... 10
Voltage vs. pressure		V / Decade	0.75
Error signal		V	0.3 / 0.5
Load impedance, min.		k	10
Set point relay			1
Range		mbar	1 x 10 ⁻⁹ ... 100
Relay contact			n.o., potential free
Hysteresis		% of reading	10
Contact rating		V / A DC	≤30 / ≤0.5
Digital functions			degas
Interface (digital) ²⁾			RS232C
Emission control			automatic / manual via interface
Filament			dual Yt ₂ O ₃ coated Ir
Filament status			LED / digital output
Electrical connection			D-sub, 15 pin, male
Cable length, max. ³⁾		m (ft)	100 (330)
Materials exposed to vacuum			Yt ₂ O ₃ , Ir, Pt, Mo, Cu, W, NiFe, NiCr, stainless steel, glass
Internal volume	KF / CF	cm ³ (inch) ³	24 (1.46) / 34 (2.1)
Weight	KF / CF	g	285 / 550
Protection type			IP30

¹⁾ Reduced accuracy during degas

²⁾ Simultaneous use of RS232C or VGC400 series controllers and Fieldbus is not allowed

³⁾ For RS232C operation <30 m

BPG402-S (continued)

Specifications

		BPG402-SP Profibus DP
Baud rates	kBaud MBaud	9.6 / 19.2 / 93.75 / 187.5 / 500 1.5 / 12
Address		2 switches (address 00 - 127) or network programmable
Digital functions		read pressure, select units: Torr, mbar, Pa emission control, degas function monitor gauge status, filament status safe state allows definition of behavior in case of error detailed alarm and warning information
Analog functions		0 ... 10 V analog output pressure indication two setpoint relays A + B
Setpoint relays		2
Range	mbar	1×10^{-9} ... 100
Relay contact		n.o., potential free
Hysteresis	% of reading	10
Contact rating	V / A DC	≤ 30 / ≤ 0.5
Connector for Profibus DP		D-sub, 9 pin, female
Connector for BPG (analog output, supply voltage, setpoints)		D-sub, 15 pin, male

Specifications

		BPG402-SD DeviceNet™
Protocol		DeviceNet, group 2 slave only
Data rate switch	kBaud	125, 250, 500 or network programmable
Cable length		
125 kbps	m (ft)	500 (1650)
250 kbps	m (ft)	250 (825)
500 kbps	m (ft)	100 (330)
MAC ID		2 switches (address 00 - 63) or network programmable
Digital functions		read pressure, select units: Torr, mbar, Pa emission control, degas function monitor gauge status, filament status safe state allows definition of behavior in case of error detailed alarm and warning information
Analog functions		0 ... 10 V analog output pressure indication two setpoint relays A + B
Specification		DeviceNet "Vacuum Gauge Device Profile"
Device type		"CG" for combination gauge
I / O slave messaging		polling only
Setpoint relays		2
Range	mbar	1×10^{-9} ... 100
Relay contact		n.o., potential free
Hysteresis	% of reading	10
Contact rating	V / A DC	≤ 30 / ≤ 0.5
Supply voltage for DeviceNet	V / A DC	11 ... 25 / < 0.2
Supply voltage for gauge	V / A DC	20 ... 28 / 0.8
Connector for DeviceNet		microstyle, 5 pin
Connector for BPG (analog output, supply voltage, setpoints)		D-sub, 15 pin, male

BPG402-S (continued)

Dimensions

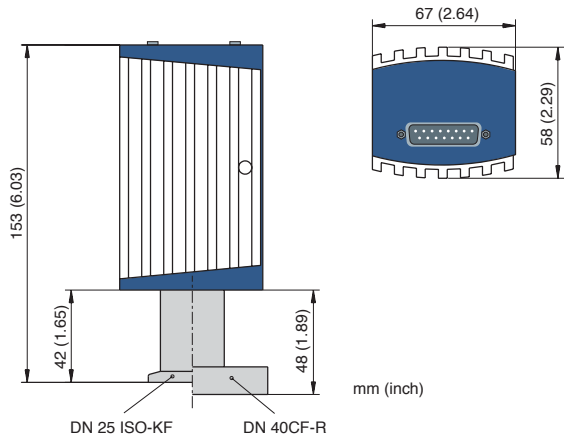

Accessories

Power supply 24 V DC / RS232C line

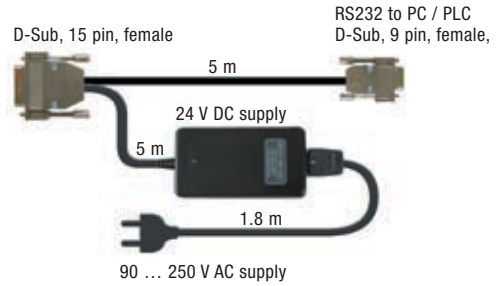

Baffle:

Prevents contamination of the sensor.
Easy installation into the vacuum connection - no tools required.



High Pressure Hot Ionization Pirani Gauge

HPG400

The INFICON High Pressure Hot Ionization Pirani Gauge, HPG400, combines High Pressure Hot Ionization and Pirani sensors in a single, compact, economical package to measure pressure from 2×10^{-6} mbar to atmosphere (1.5×10^{-6} Torr to atmosphere). The HPG400 provides highly repeatable and reproducible pressure measurement for accurate sputter process pressure control.



Advantages

- HPG400 saves cost and tool space and reduces the complexity of vacuum system installation and setup
- The high pressure hot ion gauge delivers accurate, reliable pressure measurements from 1×10^{-5} ... 1 mbar for improved process control
- User selectable hot ion emission activation between 5×10^{-2} and 1 mbar
- Pirani interlock protects the hot filament from premature burnout
- Optional graphic display and Fieldbus interfaces available
- Automatic high vacuum Pirani adjustment reduces operator interventions

Applications

- Sputter applications in semiconductor manufacturing, electronics and media industry
- Industrial coating
- General vacuum measurement and control in the low to high vacuum range

Ordering Information

Type	HPG400 without LCD display	HPG400 with LCD display	HPG400-SP with Profibus DP ¹⁾	HPG400-SD with DeviceNet ¹⁾
DN 25 ISO-KF	353-520	353-521	353-525	353-527
DN 40 CF-F	353-522	353-523	353-526	353-528
Replacement sensor 25 ISO-KF	354-487	354-487	354-487	354-487
Replacement sensor 40 CF-F	354-488	354-488	354-488	354-488

¹⁾ not available with LCD display

Accessories

Power supply 24 V DC / RS232C line

353-511

HPG400 (continued)

Specifications

		HPG400 Standard	HPG400 Display
Measurement range (air, N ₂)	mbar (Torr)	2 x 10 ⁻⁶ ... 1000	(1.5 x 10 ⁻⁶ ... 750)
Accuracy	10 ⁻⁵ ... 1 mbar	% of reading	±15 ¹⁾
Repeatability	10 ⁻⁵ ... 10 ⁻¹ mbar	% of reading	2
	10 ⁻¹ ... 100 mbar	% of reading	30
Hot ion emission on, selectable	mbar		1
	mbar		5 x 10 ⁻¹
	mbar		2 x 10 ⁻¹
	mbar		1 x 10 ⁻¹
	mbar		5 x 10 ⁻²
Pressure, max.	bar (absolute)		5
Temperature			
Operation (ambient)	°C		0 ... +50
Storage	°C		-20 ... +70
Bakeout			
At flange	°C		80
Electronics removed	°C		150
Supply voltage	V / A DC		20 ... 28 / 0.8
Output signal analog	V		0 ... +10.2
Measurement range			
Hot cathode	V		1.5 ... 7.5
Pirani	V		8.5 ... 9.75
Voltage vs. pressure			
Hot cathode	V / Decade		1
Pirani	V / Decade		0.25
Error signal			
Hot cathode	V		0.3
Pirani	V		0.5
Load impedance, min.	k		10
Interface (digital) ²⁾			RS232C
Electrical connection			D-sub, 15 pin, male
Cable length, max. ³⁾	m (ft)		100 (330)
Materials exposed to vacuum			Yt ₂ O ₃ , Ir, Pt, Mo, Cu, W, NiFe, NiCr, stainless steel, glass
Internal volume KF / CF	cm ³ (inch) ³		20 (1.2) / 30 (1.8)
Weight KF / CF	g		430 / 695
Protection type			IP30

¹⁾ Accuracy from 10⁻⁵ mbar to the selected hot ion emission on value

²⁾ Simultaneous use of RS232C or VGC400 series controllers and Fieldbus is not allowed

³⁾ For RS232C operation <30 m

HPG400 (continued)

Specifications

		HPG400-SD DeviceNet™
Protocol		DeviceNet, group 2 slave only
Data rate switch	kBaud	125, 250, 500 or network programmable
Cable length		
125 kbps	m (ft)	500 (1650)
250 kbps	m (ft)	250 (825)
500 kbps	m (ft)	100 (330)
MAC ID		2 switches (address 00 - 63) or network programmable
Network size		up to 64 nodes per segment
Digital functions		read pressure, select units: Torr, mbar, Pa Pirani full scale adjust monitor gauge status safe state allows definition of behavior in case of error detailed alarm and warning information
Analog functions		0 ... 10 V analog output pressure indication two setpoint relays A + B
Visual communication indicators		LED network status (green / red) LED module status (green / red)
Specification		DeviceNet "Vacuum Gauge Device Profile"
Device type		"CG" for combination gauge
I / O slave messaging		polling only
Setpoint relays		2
Range	mbar	2×10^{-6} ... 100
Relay contact		n.o., potential free
Hysteresis	% of reading	10
Contact rating	V DC / A	60 / 0.5
Supply voltage for DeviceNet	V DC / A	11 ... 25 / 0.5
Supply voltage for gauge	V DC	20 ... 28
Connector for DeviceNet		microstyle, 5 pin
Connector for HPG (analog output, supply voltage, setpoints)		D-sub, 15 pin, male

Specifications

		HPG400-SP Profibus DP
Baud rates	kBaud MBaud	9.6 / 19.2 / 93.75 / 187.5 / 500 1.5 / 12
Address		2 switches (address 00 - 127) or network programmable
Digital functions		read pressure, select units: Torr, mbar, Pa Pirani full scale adjust monitor gauge status safe state allows definition of behavior in case of error detailed alarm and warning information
Analog functions		0 ... 10 V analog output pressure indication two setpoint relays A + B
Setpoint relays		2
Range	mbar	1×10^{-6} ... 100
Relay contact		n.o., potential free
Hysteresis	% of reading	10
Contact rating	V DC / A	60 / 0.5
Connector for Profibus DP		D-sub, 9 pin, female
Connector for HPG (analog output, supply voltage, setpoints)		D-sub, 15 pin, male

HPG400 (continued)

Dimensions

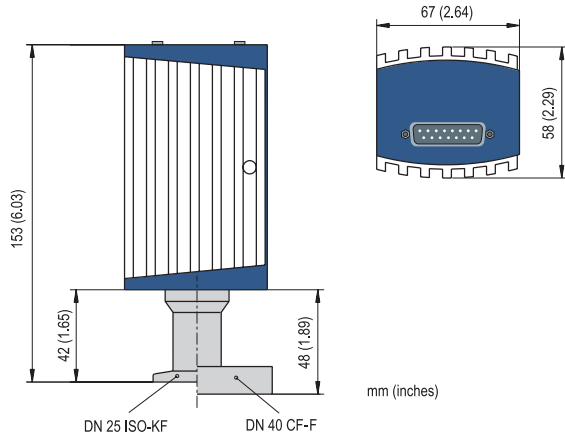

Accessories

Power supply 24 V DC / RS232C line

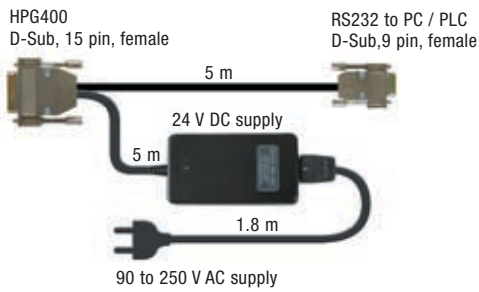

Bayard-Alpert Pirani Capacitance Diaphragm Gauge

TripleGauge® BCG450

The INFICON Bayard-Alpert Pirani Capacitance Diaphragm Gauge, BCG450, combines the advantages of three different technologies in a single, compact, economical package to measure process and base pressure from 5×10^{-10} to 1500 mbar (3.75×10^{-10} to 1125 Torr). The BCG450 is designed to take the place of three sensors (hot ion, convection enhanced Pirani and vacuum switch), thus reducing cost and valuable tool space.

Advantages

- BCG450 saves cost and tool space and reduces the complexity of vacuum measurement installation and setup
- Gas-type-independent pressure measurement above 10 Torr provides more reliable loadlock control for any gas-mixture
- Pirani interlock protects the hot filament from premature burnout
- Automatic high vacuum and atmospheric Pirani adjustment reduces operator interventions
- Differential pressure measurement at atmosphere eliminates uncertainty related to atmospheric pressure changes
- Easy-to-exchange sensing element with on-board calibration data guarantees reproducibility
- Optional graphic display and Fieldbus interfaces available

Applications

- Pressure measurement in semiconductor process, transfer and loadlock chambers
- Industrial coating
- General vacuum measurement and control on systems in the low to ultra-high vacuum range



2004 Award Winner



TripleGauge
Bayard-Alpert
Pirani Capacitance
Diaphragm Gauge

Ordering Information

Type	BCG450 without LCD display	BCG450 with LCD display	BCG450-SP with Profibus DP ²⁾	BCG450-SD with DeviceNet ²⁾	BCG450-SR with RS485 ¹⁾²⁾
DN 25 ISO-KF	353-550	353-552	353-554	353-557	353-559
DN 40 CF-R	353-551	353-553	353-556	353-558	353-560
Replacement sensor 25 ISO-KF	354-492	354-492	354-492	354-492	354-492
Replacement sensor 40 CF-R	354-493	354-493	354-493	354-493	354-493

¹⁾ available on request

²⁾ not available with LCD display

Accessories

Power supply 24V DC / RS 232 C line	353-511
Baffle	353-512
Centering ring with baffle	211-113

TripleGauge® BCG450 (continued)

Specifications

		BCG450 Standard	BCG450 Display
Measurement range	mbar (Torr)	5 x 10 ⁻¹⁰ to 1500 (3.75 x 10 ⁻¹⁰ to 1125)	
Accuracy	10 ⁻⁸ to 10 ⁻² mbar	% of reading ±15	
	10 ⁻² to 50 mbar	% of reading ±15	
	50 to 950 mbar	% of reading ±5	
	950 to 1050 mbar	% of reading ±2.5	
Repeatability	10 ⁻⁸ ... 10 ⁻² mbar	% of reading 5	
Hot ion emission on	mbar	2 x 10 ⁻² (high)	
(selectable high / low, via RS232 / Fieldbus)	mbar	8 x 10 ⁻³ (low)	
Degas ¹⁾ p < 7.2 x 10 ⁻⁶	mbar	Electron bombardment, max. 3 min	
Pressure, max.	bar (absolute)	5	
Temperature			
Operation (ambient)	°C	0 to +50	
Storage	°C	-20 to +70	
Bakeout			
At flange	°C	80	
Electronics removed	°C	150	
Supply	V / A DC	20 to 28 / 0.8	
Output signal analog	V	0 to 10.3	
Measurement range	V	0.774 to 10.3	
Relation voltage / pressure	V / Decade	0.75	
Error signal	V	0.3 / 0.5	
Minimum load	k	10	
Interface (digital) ²⁾		RS232C	
Connector		D-sub, 15 pin, male	
Cable length, max. ³⁾	m (ft)	100 (330)	
Materials exposed to vacuum		Yt ₂ O ₃ , Ir, Mo, Cu, W, NiFe, NiCr, Al ₂ O ₃ , SnAg, stainless steel, glass	
Internal volume KF / CF	cm ³ (inch) ³	24 (1.46) / 34 (2.1)	
Weight KF / CF	g	285 / 550	
Protection type		IP30	

¹⁾ Reduced accuracy during degas

²⁾ Simultaneous use of RS232C or VGC400 series controllers and Fieldbus is not allowed

³⁾ For RS232C operation <30m

TripleGauge® BCG450 (continued)

Specifications

		BCG450-SD DeviceNet™
Protocol		DeviceNet, group 2 slave only
Data rate switch	kBaud	125, 250, 500 or network programmable
Cable length		
125 kbps	m (ft)	500 (1650)
250 kbps	m (ft)	250 (825)
500 kbps	m (ft)	100 (330)
MAC ID		2 switches (address 00 - 63) or network programmable
Network size		Up to 64 nodes per segment
Digital functions		Read pressure, select units: Torr, mbar, Pa Degas function Monitor gauge status Safe state allows definition of behavior in case of error Detailed alarm and warning information
Analog functions		0 to 10 V analog output pressure indication Two setpoint relays A + B
Visual communication indicators		LED network status (green / red) LED module status (green / red)
Specification		DeviceNet "Vacuum Gauge Device Profile"
Device type		"CG" for combination gauge
I / O peer to peer messaging		polling only
Configuration consistency value		no
Faulted node recovery		no
Baud rates	kBaud	125 / 250 / 500
Master / Scanner		no
I / O slave messaging		polling only
Setpoint relays		2
Range	mbar	1×10^{-9} to 1400
Relay contact		n.o., potential free
Hysteresis	% of reading	10
Contact rating	V / A DC	60 / 0.5
Connector		D-sub, 15 pin, male
Supply for DeviceNet	V / A DC	11 to 25 / 0.5
Supply for gauge	V DC	20 to 28
Connector for DeviceNet		Microstyle, 5 pin
Connector for BCG (analog output, supply voltage, setpoints)		D-sub, 15 pin, male

TripleGauge® BCG450 (continued)

Specifications

			BCG450-SP Profibus DP
Baud rates	kBaud		9.6 / 19.2 / 93.75 / 187.5 / 500
	MBaud		1.5 / 12
Address			2 switches (address 00 - 127) or network programmable
Digital functions			Read pressure, select units: Torr, mbar, Pa Degas function Monitor gauge status Safe state allows definition of behavior in case of error Detailed alarm and warning information
Analog functions			0 to 10 V analog output pressure indication Two setpoint relays A + B
Setpoint relays			2
Range	mbar		1×10^{-9} to 1400
Relay contact			n.o., potential free
Hysteresis	% of reading		10
Contact rating	V / A DC		60 / 0.5
Connector			
	for Profibus DP		D-sub, 9 pin, female
	for BCG (analog output, supply voltage, setpoints)		D-sub, 15 pin, male

Specifications

			BCG450-SR RS485
Baud rates	kBaud		0.3 / 1.2 / 2.4 / 4.8 / 9.6 / 19.2 / 28.8
Address			2 switches (address 00 - 127) or network programmable
Digital functions			Read pressure, select units: Torr, mbar, Pa Degas function, Pirani full scale adjust Monitor gauge status Detailed alarm and warning information
Analog functions			0 to 10 V analog output pressure indication Two adjustable setpoint relays A + B
Setpoint relays			2
Range	mbar		1×10^{-9} to 100
Relay contact			n.o., potential free
Hysteresis	% of reading		10
Contact rating	V / A DC		60 / 0.5
Connector			
	for RS485		D-sub, 9 pin, male
	for gauge (analog output, supply voltage, setpoints)		D-sub, 15 pin, male

TripleGauge® BCG450 (continued)

Dimensions

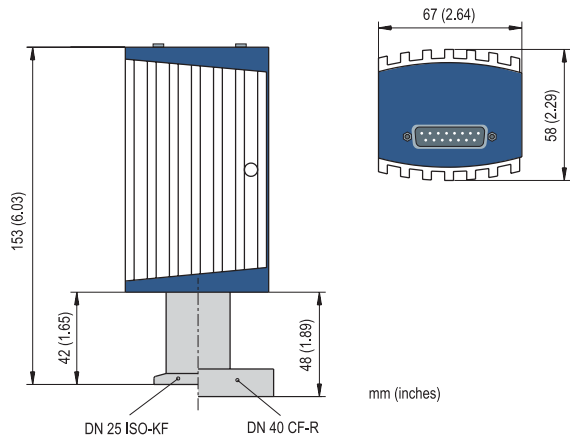

Accessories

Power supply 24 V DC / RS 232 C line

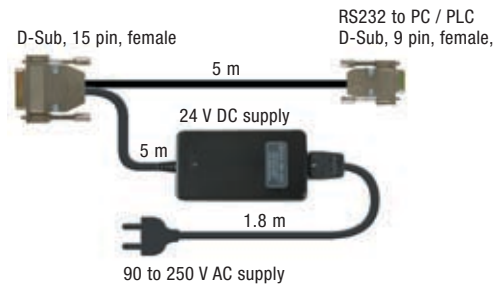

Baffle

Prevents contamination of the sensor.
Easy installation into the vacuum connection - no tools required.



Pirani Standard Gauge

PSG050 / PSG051

Advantages

- Measurement range 5×10^{-4} to 1000 mbar (3.75×10^{-4} to 750 Torr)
- Tungsten or platinum filament
- Temperature compensated 0°C to 40°C
- Constant filament temperature

PSG050:

- Aluminum sensing cell with tungsten filament
- Excellent temperature compensation

PSG050 1/8" NPT:

- Stainless steel sensing cell with tungsten filament

PSG051:

- Stainless steel sensing cell with platinum filament and ceramics feedthrough
- Well suited for corrosive processes and water vapor atmospheres



Operating Units

- Vacuum Gauge Controller VGC012 / VGC023

Ordering Information

Type	PSG050	PSG050 1/8" NPT	PSG051
DN 16 ISO-KF	399-500	–	399-502
1/8" NPT	–	399-501	–
Replacement sensing cell DN 16 ISO-KF	350-980	–	350-981

Ordering information for cables - see Data Sheets of VGC012 / VGC023

Specifications

		PSG050	PSG050 1/8" NPT	PSG051
Measurement range	mbar (Torr)	5 x 10 ⁻⁴ to 1000 (3.75 x 10 ⁻⁴ to 750)		
Temperature				
Operation (ambient)	°C	0 to +40	0 to +40	0 to +40
Storage	°C	80	80	80
Filament		Tungsten	Tungsten	Platinum
Filament temperature	°C	110	110	110
Pressure, max. absolute	bar	3	3	10
Volume of the sensing cell, approx.	cm ³	11	11	10
Vacuum connection		DN 16 ISO-KF	1/8" NPT	DN 16 ISO-KF
Materials exposed to vacuum		Tungsten, aluminum, nickel-plated steel, stainless steel, NiFe, glass CrNi, epoxy cement	Tungsten, stainless steel, NiFe, glass, CrNi, epoxy cement	Platinum, stainless steel, CrNi, AL ₂ O ₃ , NiFe

Additional specifications - see Data Sheets and Operating Manuals VGC012 / VGC023

Dimensions

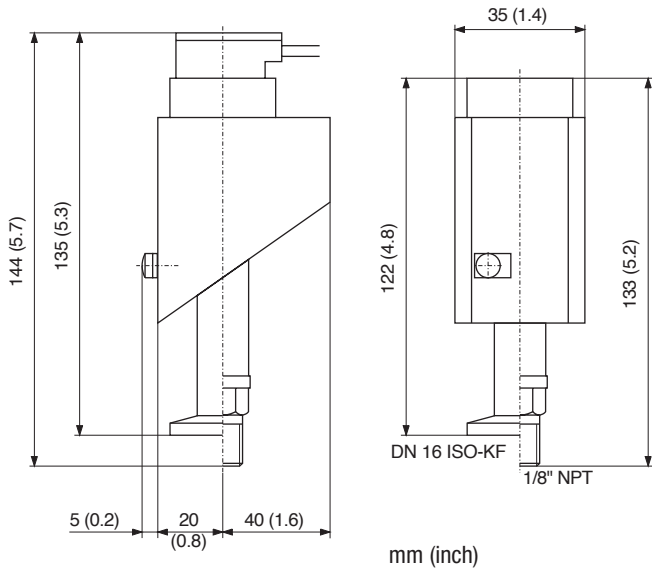

Pirani Standard Gauge

PSG100-S, PSG101-S

The INFICON Pirani Standard Gauges PSG100-S and PSG101-S are especially designed for easy integration into vacuum systems using Profibus DP or DeviceNet™ fieldbus protocols. The gauges are equipped with a setpoint and for corrosive applications, a platinum filament version is available.



Advantages

- Fieldbus interface (Profibus DP, DeviceNet™) for easy integration into vacuum systems using network communications
- For corrosive applications or high levels of water vapors the PSG101-S uses a platinum filament and a Al₂O₃ ceramic feedthrough
- Setpoint with adjustable threshold over a wide range
- Mounts in any orientation
- Logarithmic analog output signal
- Sensor cell is easily replaced

Applications

- Processes with corrosive gases (PSG101-S)
- Fore vacuum pressure monitoring
- Control of high vacuum ionization gauges
- Safety circuits in vacuum systems
- General vacuum measurement and control in the fine and rough vacuum range

Ordering Information

Type	PSG100-S DN 16 ISO-KF, Tungsten	PSG101-S DN 16 ISO-KF, Platinum
With setpoint	350-020	350-030
With DeviceNet™ (PSG100-SD, PSG101-SD)	350-021	350-031
With Profibus DP (PSG100-SP, PSG101-SP)	350-022	350-032
Replacement sensor (DN16 ISO KF)	350-980	350-981

PSG100-S, PSG101-S (continued)

Specifications

		PSG100-S Tungsten	PSG101-S Platinum
Measurement range (air, O ₂ , CO, N ₂)	mbar Torr	5 x 10 ⁻⁴ ... 1000 3.8 x 10 ⁻⁴ ... 750	
Filament material		tungsten	platinum
Mounting orientation		any	
Feldbus protocol		DeviceNet™ or Profibus DP	
Setpoint		1	
Range	mbar	1 x 10 ⁻³ ... 500	
Relay contact		n.o. / potential free	
Hysteresis		≈30% of adjusted pressure	
Contact rating	VDC / A	60 / 0.5	
Relay status		LED, green	
Pressure, max. (absolute)	bar	3	10 ¹⁾
Temperature			
Operation (ambient)	°C	+10 ... +50	
Storage	°C	-20 ... +70	
Bakeout at flange	°C	80	
Power supply			
Voltage	V DC	14.5 ... 36	
Consumption, max.	W	<2	
Output signal analog	V	0 ... 10.6	
Measurement range	V	0.66 ... 10	
Relation voltage / pressure	V / Decade	1.333	
Connector		FCC 68, female, 8 pin (shielded)	
Cable length, max. (analog)	m (ft)	100 (330)	
Materials exposed to vacuum		tungsten, Al, nickel-plated steel, stainless steel, NiFe, glass, CrNi8020, epoxy cement	platinum, stainless steel, CrNi, Al ₂ O ₃ ceramics, NiFe, Mo, Ni
Flange		DN 16 ISO-KF	
Internal volume	DN 16 ISO-KF	cm ³ (inch) ³	11 (0.67)
Weight, approx.	DN 16 ISO-KF	g	290
Protection type			IP40

¹⁾ Threaded connections only

Specifications

		PSG100-SP Profibus DP, PSG101-SP Profibus DP
Supported baud rates (for auto detection)	kBaud	9.6 / 19.2 / 93.75 / 187.5 / 500 / 1500
Expanded user parameter data	Bytes	5
Configuring		
Number of input and output data		2
Sync-Mode and Freeze-Mode		Yes
Connector		D sub, 9 pin

Specifications

		PSG100-SD DeviceNet™, PSG101-SD DeviceNet
Device type		generic
Explicit peer to peer messaging		no
I / O peer to peer messaging		no
Configuration consistency value		no
Faulted node recovery		no
Baud rates	kBaud	125 / 250 / 500
Master / Scanner		no
I / O slave messaging		
Bit Strobe		yes
Polling		yes
Cyclic		yes
Change of State (COS)		yes
Supply for DeviceNet	V DC	11 to 25
Connector for DeviceNet		Phoenix Combicon, 5 pin

Dimensions

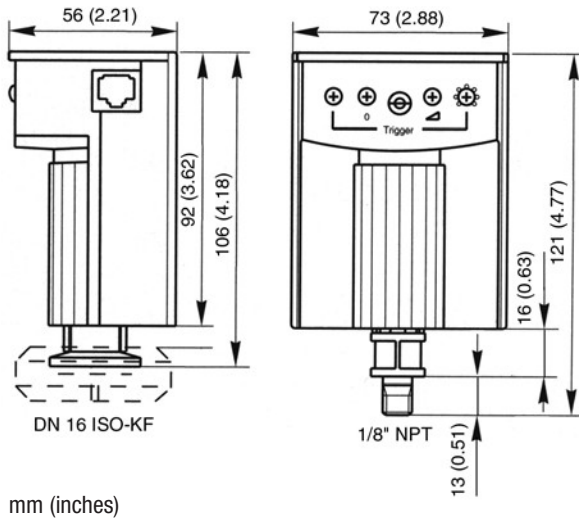

Pirani Standard Gauge

PSG500/-S, PSG502-S, PSG510-S, PSG512-S

The INFICON Pirani Standard Gauges, PSG500, PSG502-S, PSG510-S and PSG512-S, employ the most advanced digital Pirani technology available in the marketplace. The rugged stainless steel sensor cell and compact design qualify them for use on semiconductor systems and for standard applications, such as fore vacuum lines.

Advantages

- Easy push button ATM and HV adjustment
- Space saving rugged design
- Aluminum housing
- Mounts in any orientation
- Stainless steel measuring cell with metal-sealed feedthrough
- Logarithmic signal output for easy integration
- 10 bar absolute overpressure with threaded connections
- 250°C bakeable version
- Nickel filament option for corrosive applications
- Ceramic feedthrough for extremely corrosive applications (PSG510 & PSG512)
- Optional setpoints
- RoHS compliance

Applications

- Controlling high vacuum ionization gauges
- Fore vacuum pressure monitoring
- Safety circuits in vacuum systems
- General vacuum measurement and control in the fine and rough vacuum range



PSG500/-S, PSG502-S, PSG510-S, PSG512-S (continued)

Ordering Information

Type Setpoints Filament	PSG500 none tungsten	PSG500-S two setpoints tungsten	PSG502-S two setpoints nickel	PSG510-S two setpoints tungsten	PSG512-S two setpoints nickel
DN 16 ISO-KF	350-060	350-080	350-140	350-200	350-300
DN 16 CF-R	350-062	350-082	350-142		
1/8" NPT	350-061	350-081	350-141		
8 VCR®	350-064	350-084	350-144		
4 VCR®	350-065	350-085	350-145		
1/2" tube	350-063	350-083	350-143		
7/16-20 UNF	350-066	350-086	350-146		
DN 16 ISO-KF long tube	350-067	350-087	350-147		
DN 16 CF-R long tube	350-068	350-088	350-148		
Replacement sensor Filament		tungsten	nickel	tungsten	nickel
DN 16 ISO-KF		350-920	350-900	350-930	350-940
DN 16 CF-R		350-922	350-902		
1/8" NPT		350-921	350-901		
8 VCR®		350-924	350-904		
4 VCR®		350-926	350-906		
1/2" tube		350-923	350-903		
7/16-20 UNF		350-925	350-905		
DN 16 ISO-KF long tube		350-927	350-907		
DN 16 CF-R long tube		350-928	350-908		

PSG500/-S, PSG502-S, PSG510-S, PSG512-S (continued)

Specifications

Type Filament		PSG500 tungsten	PSG500-S tungsten	PSG502-S nickel	PSG510-S tungsten	PSG512-S nickel
Measuring principle		thermal conductance according to Pirani				
Measurement range (air, O ₂ , CO, N ₂)	mbar	5 x 10 ⁻⁴ to 1000				
Accuracy (N ₂)	1 x 10 ⁻³ ... 100 mbar	% of reading				
	5 x 10 ⁻⁴ ... 1 x 10 ⁻³ mbar	% of reading				
	100 ... 1000 mbar	% of reading				
Resolution		% of reading				
Repeatability (air)	1 x 10 ⁻³ ... 100 mbar	% of reading				
Output signal (measurement signal)						
Voltage range	V	0 ... +10.3				
Measurement range	V	+1.9 ... +10.0				
Voltage vs. pressure		logarithmic 1.286 V/decade				
Error signal	V	0 ... +0.5 (filament rupture)				
Output impedance		2 x 4.7				
Minimum loaded impedance	k	10, short-circuit proof				
Response time	ms	80				
Gauge identification	k	27.0, referenced to supply common				
Adjustment		one tactile switch for ATM and HV adjustment				
Setpoint		none		2		
Setting range	mbar	2 x 10 ⁻³ ... 500				
Hysteresis	% of reading	10% above lower threshold				
Relay contact	V DC / A DC	30 / 0.5 floating				
Switching time	ms	<20				
Supply voltage						
At gauge	V DC	+14 ... +30				
Ripple	V _{pp}	≤1				
Current consumption	mA	<500 (max. starting current)				
Power consumption	W	≤1				
Electrical connection		FCC 68 / RJ45 appliance connector, 8 poles, male				
Sensor cable		8 poles plus shielding				
Cable length	m	≤100 (8 x 0.14 mm ²)				
Materials exposed to vacuum		glass, Ni, NiFe			Al ₂ O ₃ , Ni,	
Filament		DIN 1.4301/1.4305/1.4435			DIN 1.3981/1.4305/1.4435	
		W	W	Ni	W	Ni
Internal volume						
DN 16 ISO-KF, DN 16 CF-R, 7/16-20 UNF	cm ³	1.5				
DN 16 ISO-KF & DN 16 CF-R long tube	cm ³	10				
1/8" NPT, 4 VCR, 8 VCR, 1/2" tube	cm ³	2				
Admissible pressure	bar (absolute)	10, limited to inert gases				
Admissible temperature						
Operation	°C	+5 ... +60				
Vacuum connection ¹⁾	°C	80 / 250 ²⁾				
Storage	°C	-20 ... +65				
Mounting orientation		any				
Degree of protection		IP40				
Weight						
DN 16 ISO-KF, 7/16-20 UNF	g	80				
DN 16 CF-R, 4 VCR	g	100				
1/8" NPT, 1/2" tube	g	70				
8 VCR, DN 16 ISO-KF long tube	g	130				
DN 16 CF-R long tube	g	140				

¹⁾ In horizontal mounting orientation

²⁾ Long tube

PSG500/-S, PSG502-S, PSG510-S, PSG512-S (continued)

Dimensions

mm (inch)

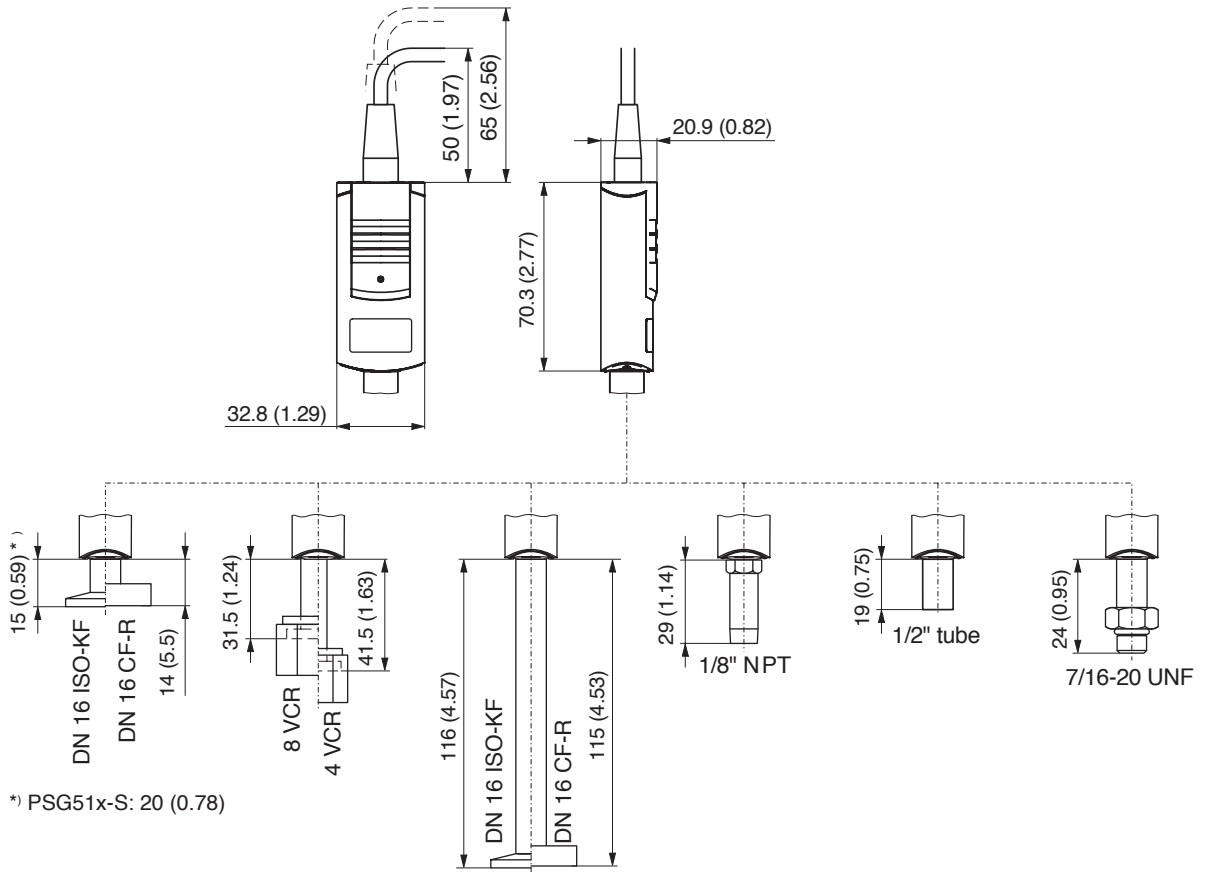

Pirani Capacitance Diaphragm Gauge

PCG400, PCG410

The INFICON PCG Pirani Capacitance Diaphragm Gauge is the first vacuum gauge to combine the advantages of a ceramic capacitance diaphragm gauge and the cost effectiveness of a Pirani in one compact package. In the measurement range between 100 mbar (75 Torr) and atmosphere, where Pirani sensors lose sensitivity, the capacitance diaphragm technology supplies accurate, gas-type and flow independent measurement values up to 1500 mbar (1125 Torr). Available with up to two integrated relays, the PCG can eliminate the need for 1/2 atm or other expensive switches. To simplify tool integration, the Pirani and CDG signals are combined into a single log/linear analog output spanning the full range of the gauge.



Advantages

- Gas-type-independent above 100 mbar (75 Torr) - enables safe venting with any gas mixture
- Higher accuracy and reproducibility at atmosphere - for reliable detection of atmospheric pressure, no frequent readjustment at atmospheric pressure anymore
- Independence of mounting position - provides engineering freedom in tool design
- Faster atmosphere detection - eliminates waiting time and thus shortens process cycle time
- Compact design - saves valuable space on the tool
- One log/linear output signal over the entire range - for easy tool integration

Applications



- Loadlock control
- Forevacuum pressure monitoring
- Safety circuits in vacuum systems
- General measurement and control in the medium and rough vacuum range
- Control of high vacuum ionization gauges

Ordering Information

Type Setpoint Connector	PCG400 none FCC 68	PCG400-S with 2 setpoints FCC 68	PCG410 none 9 D-Sub	PCG410-S with 1 setpoint 9 D-Sub
DN 16 ISO-KF	355-000	355-010	355-020	355-030
1/8" NPT	355-001	355-011	355-021	355-031
DN 16 CF-F	355-002	355-012	355-022	355-032
8 VCR®, female	355-004	355-014	355-024	355-034
4 VCR®, female	355-005	355-015	355-025	355-035
4 VCR® 90°, female			355-026	

PCG400, PCG410 (continued)

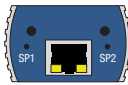
Specifications

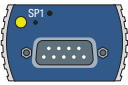
	PCG400 FCC 68	PCG400-S FCC 68	PCG410 9 D-Sub	PCG410-S 9 D-Sub
				
	for INFICON VGC40x vacuum gauge controllers		for direct connection to PC / PLC	
Electrical connection	FCC 68, 8 pin		D-Sup, 9 pin, male	
Measurement range	mbar	5×10^{-4} to 1500		
	Torr	3.8×10^{-4} to 1125		
Accuracy (N ₂)				
1 x 10 ⁻³ ... 50 mbar	% of reading	±15%		
50 ... 950 mbar	% of reading	±5%		
ATM (950 ... 1050 mbar)	% of reading	±2.5%		
Repeatability (N ₂)				
1 x 10 ⁻³ to 1100 mbar	% of reading	±2%		
Mounting orientation		any		
Setpoint	none	2	none	1
Range (N ₂)	mbar	1.5×10^{-3} ... 1400		1.5×10^{-3} ... 1400
Relay contact		n.o. / potential free		n.o. / potential free
Hysteresis		10% of threshold		10% of threshold
Contact rating	V DC / A	30 / 1		30 / 1
Relay status		LED, green		LED, green
Pressure, max. (absolute)	bar	5		
Temperature				
Operation (ambient)	°C	+10 ... +50		
Storage	°C	-20 ... +65		
Bakeout at flange	°C	+80		
Filament	°C	<160		
Power supply				
Voltage	V DC	15 ... 30 (Ripple ≤ 1 V _{pp})		
Consumption, max.	W	2.5		
Output signal analog	V	0 ... +10.3	0 ... +9.0	
Measurement range, logarithmic	V	+1.9 ... +10.23	+2.2 ... +8.68	
Relation voltage / pressure	V / Decade	1.286	1	
Response time	ms	10	10	
Connector		FCC 68, female, 8 pin (shielded)		
Cable length, max.	m (ft)	100 (330)		
Materials exposed to vacuum		Al ₂ O ₃ (>99.5%), tungsten, stainless steel, Cu, glass, NiFe, Ni SnAg, AgPd		
Internal volume KF / CF	cm ³	6 / 8		
Weight KF / CF	g	90 / 120		
Protection type		IP 40		

PCG400, PCG410 (continued)

Dimensions

mm (inch)

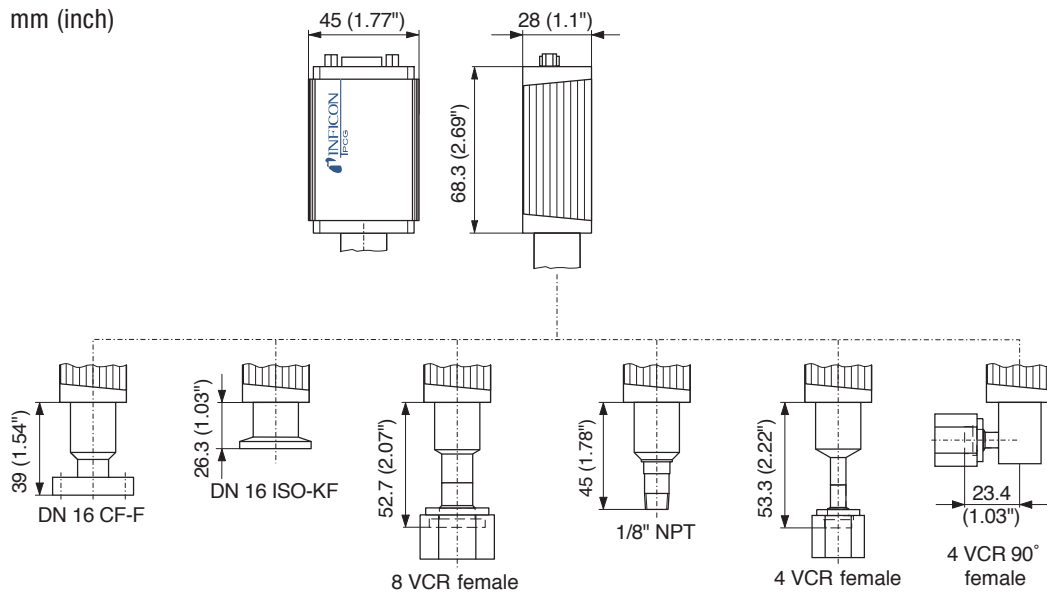

Penning Gauge

PEG100

The INFICON Penning Gauge PEG100 provides reliable high vacuum measurements. The rugged Penning cold cathode sensor has no filament to burn out. Due to titanium cathode plates and the reduced high voltage after plasma ignition, the gauge can be operated also in sputtering applications. The fieldbus options, in addition to the logarithmic analog output signal, allow easy integration into vacuum systems using Profibus DP or DeviceNet protocols.

ADVANTAGES

- Wide measurement range from 5×10^{-9} to 1×10^{-2} mbar (7.5×10^{-10} to 7.5×10^{-3} Torr)
- All-metal cold cathode sensor (Penning) with ceramic feedthrough
- Innovative electrode geometry provides excellent ignition properties
- Decreased high voltage after plasma ignition and titanium cathode plates reduce risk of contamination, even during sputtering operations with argon
- The anode ring and the titanium cathode can be cleaned or replaced easily
- Minimal magnetic field intensity adjacent to gauge
- LED indicator for power on and plasma ignited
- Logarithmic analog output signal
- Fieldbus interface (Profibus DB, DeviceNet) for easy integration into vacuum systems using network communications

APPLICATIONS

- High vacuum pressure monitoring
- Evaporation and sputtering systems
- General vacuum measurement and control in the fine and high vacuum range



Ordering Information

Type	PEG100	PEG100-D with DeviceNet™	PEG100-P with Profibus DP™
DN 25 ISO-KF	351-000	351-003	351-005
DN 40 CF-R	351-002	351-004	—
Replacement cathode plates, titanium Set of 5 pieces	351-490	351-490	351-490

PEG100 (continued)

Specifications

			PEG100
Measurement range	mbar		1×10^{-9} to 1×10^{-2}
	Torr		7.5×10^{-10} to 7.5×10^{-3}
Accuracy	10^{-8} to 10^{-4} mbar	% of reading	±30
Pressure, max. absolute		bar	10
Temperature			
Operation (ambient)		°C	+10 to +50
Storage		°C	-20 to +75
Bakeout			
	without electronics	°C	350
	with electronics, at flange	°C	70
Supply			
Voltage		V DC	14.5 to 36
Consumption, max.		W	<2
Output signal analog			
Measurement range		V	0 to 10.6
Relation voltage / pressure		V / Decade	1.333
Connector			FCC 68, female, 8 pin (shielded)
Cable length, max. (analog)		m (ft)	100 (330)
Materials exposed to vacuum			
Internal volume		cm ³ (inch) ³	21 (1.28)
Weight, approx.		g	500
Protection type			IP40

Specifications

			PEG100-D DeviceNet™
Device type			generic
Explicit peer to peer messaging			no
I / O peer to peer messaging			no
Configuration consistency value			no
Faulted node recovery			no
Baud rates		kBaud	125 / 250 / 500
Master / Scanner			no
I / O slave messaging			
	Bit Strobe		yes
	Polling		yes
	Cyclic		yes
	Change of State (COS)		yes
Supply for DeviceNet		V DC	11 to 25
Connector for DeviceNet			Phoenix Combicon, 5 pin

Specifications

			PEG100-P Profibus DP™
Supported baud rates (auto detection)		kBaud	9.6 / 19.2 / 93.75 / 187.5 / 500 / 1500
Expanded user parameter data		Bytes	5
Configuring			
	Number of input and output data		2
Sync-Mode and Freeze-Mode			Yes
Connector			D-sub, 9 pin

PEG100 (continued)

Dimensions

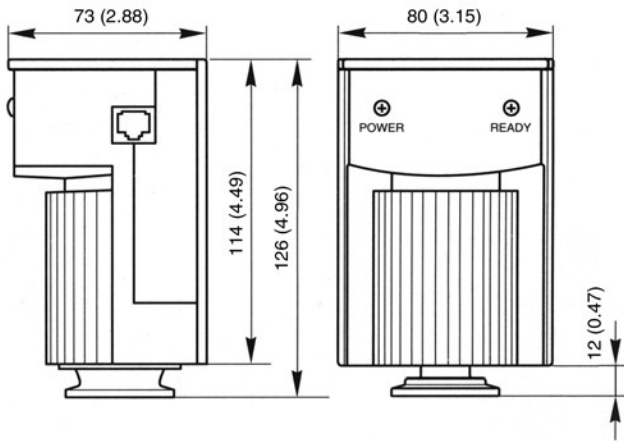

Inverted Magnetron Pirani Gauge

MPG400/401

The INFICON Inverted Magnetron Pirani Gauges, MPG400 and MPG401, measure from 5×10^{-9} mbar to atmosphere (3.8×10^{-9} Torr to atmosphere). Combining technologies into one single compact unit with one logarithmic analog output signal significantly reduces the complexity of installation, setup and integration.



ADVANTAGES

- Combination gauge – Inverted Magnetron & Pirani
- Wide measurement range from 5×10^{-9} mbar to atmosphere
- No filament to burn out
- Excellent ignition properties
- Easy to clean
- FPM or metal-sealed feedthrough
- LED indicator for high voltage on
- Logarithmic analog output signal

APPLICATIONS

- High vacuum pressure monitoring
- Base pressure for evaporation and sputtering systems
- General vacuum measurement and control in the medium and high vacuum range

Ordering Information

Type	MPG400 FPM sealed	MPG401 metal-sealed
DN 25 ISO-KF	351-010	351-020
DN 40 ISO-KF	351-011	351-021
DN 40 CF-F	351-012	351-022

Accessories

Type	MPG400 FPM sealed	MPG401 metal-sealed
Magnetic shield	351-023	351-023

MPG400/401 – continued

Specifications

		MPG400 FPM sealed	MPG401 metal-sealed
Measurement range (air, N ₂)	mbar (Torr)	5 x 10 ⁻⁹ ... 1000	(3.8 x 10 ⁻⁹ ... 760)
Accuracy (N ₂)	1 x 10 ⁻⁸ ... 100 mbar	% of reading	≈±30%
Repeatability	1 x 10 ⁻⁸ ... 100 mbar	% of reading	≈±5%
Mounting orientation			any
Admissible pressure	bar (absolute)		≤10 (limited to inert gases)
Admissible temperature			
Operation (ambient)	°C		+5 ... +55
Storage	°C		-40 ... +65
Bake-out ¹⁾	°C		150
Filament temperature (Pirani)	°C		120
Supply voltage			
At gauge	V DC		+15 ... +30
At supply unit with max. cable length ²⁾	V DC		+16 ... +30
Ripple	V _{pp}		≤1
Power consumption	W		≤2
Fuse to be connected	AT		≤1
Output signal (measurement signal)			
Voltage range	V		0 ... +10.5
Measurement range	V		+1.82 ... +8.6
Voltage vs. pressure			logarithmic, 0.6 V/decade
Error signal	V		<0.5 (no supply)
	V		>9.5 (Pirani sensor, filament rupture)
Output impedance			2 x 10
Minimum loaded impedance	k		10, short-circuit proof
Response time	p > 10 ⁻⁶ mbar	ms	<10
	p = 10 ⁻⁸ mbar	ms	≈1000
Identification gauge	k		85, referenced to supply common
Status			
Pirani-only mode		V	0 (low)
Combined Pirani / cold cathode mode	V		15 ... 30 (high)
LED	LED green		high voltage on
Electrical connection			FCC 68 appliance connector, 8 poles, female
Sensor cable			8 poles plus shielding
Cable length	m		≤50 (8 x 0.14 mm ²)
Operating voltage	kV		≤3.3
Operating current	μA		≤500
Materials exposed to vacuum		stainless steel, Al ₂ O ₃ , FPM75, Mo, Ni, Au, W	stainless steel, Al ₂ O ₃ , Ag, Cu, Sn Mo, Ni, Au, W
Internal volume	cm ³		≈20
Weight			
DN 25 ISO-KF	g	≈700	≈730
DN 40 ISO-KF	g	≈720	≈750
DN 40 CF-F	g	≈980	≈1010
Protection category			IP 40
Standards			EN 61000-6-2, EN 61000-6-3, EN 61010-1

¹⁾ Without electronics and magnetic shielding.

²⁾ The minimum voltage of the supply unit must be increased proportionally to the length of the sensor cable.

Dimensions

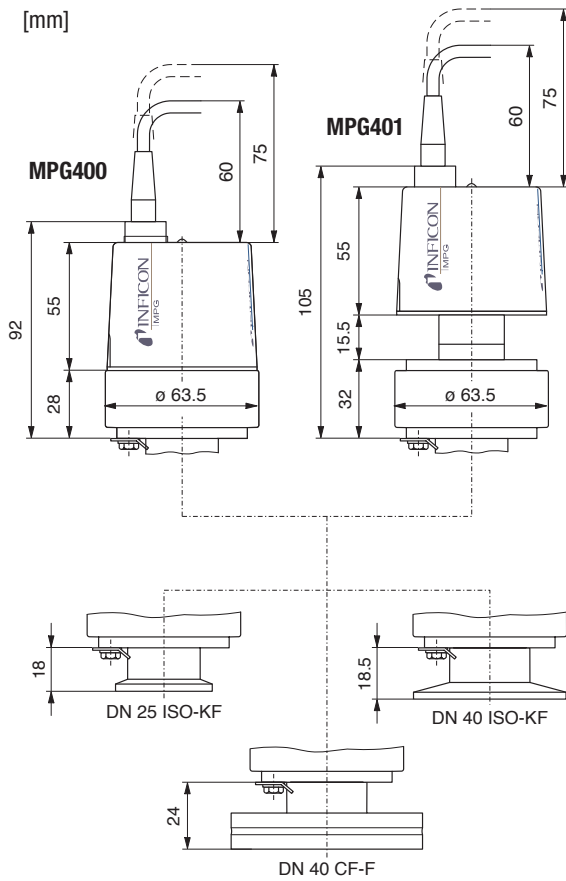

Spare Parts

Type	MPG400 FPM sealed	MPG401 metal-sealed
Maintenance kit includes: support/centering ring seals ignition aid	351-999	351-997
Repair kit includes: Pirani element anode anode extension ¹⁾ Cu seal ¹⁾ screw fitting ¹⁾ support/centering ring seals ignition aid	351-998	351-996
Ignition aid kit includes: ignition aid	351-995	351-995
Mounting tool for ignition aid	351-994	351-994

¹⁾ MPG401 only

Vacuum Gauge Controllers

VGC401, VGC402, VGC403

Your complete solution for process measurement and control.

Compatible with all INFICON active gauges, the VGC400 series of controllers can monitor the entire pressure range from 10^{-10} to 1500 mbar (10^{-10} to 1125 Torr) and the setpoint status.

Advantages

- Automatic identification of the connected INFICON gauges
- User selectable measurement unit (mbar, Torr, Pascal, micron)
- High resolution – 16 bit A/D converter
- Up to six adjustable setpoints with adjustable hysteresis may be assigned to any channel
- Programmable 0 to 10 V chart recorder output with logarithmic / linear characteristics for each gauge or gauge combination (VGC402/403 only)
- Firmware upgrades available on-line are easily downloaded via the RS232 interface
- Versatile, compact bench-top model design can easily be mounted in a panel or 19" rack
- Wide range power supply 90 to 250V, 50 to 60Hz

VGC401



VGC402



VGC403



Ordering Information

Type	VGC401	VGC402	VGC403
Vacuum Gauge Controller	398-010	398-020	398-021
Adapter for rack mount 2HE / 3HE	398-499	–	–

Accessories

Gauges	PCG, PEG, PSG, MPG	BAG, BCG, BPG, HPG CDG	CDG (unheated)
Signal read out / communication	analog	digital analog possible	analog
Connector	FCC / FCC	D-Sub / D-Sub	FCC / D-Sub
Cable to VGC401/402/403 in m (ft)			
3 (9.9)	398-500	398-520	398-540
5 (16.5)	398-501	398-521	398-541
10 (33.0)	398-502	398-522	398-542
15 (49.5)	398-503	398-523	398-543
20 (66.0)	398-504	398-524	398-544
30 (99.0)	398-505	398-525	398-545

other lengths on request

VGC401, VGC402, VGC403 (continued)

Specifications

Type		VGC401	VGC402	VGC403
Measurement channels		1	2	3
Display		LED	LCD	LCD
Range	mbar (Torr)	$2 \times 10^{-10} \dots 1500$ $(1.5 \times 10^{-10} \dots 1125)$	$5 \times 10^{-10} \dots 1500$ $(3.75 \times 10^{-10} \dots 1125)$	$5 \times 10^{-10} \dots 1500$ $(3.75 \times 10^{-10} \dots 1125)$
Rate	1/s	10	10	10
A/D converter	bit	16	16	16
Connectable gauges with display range				
CDG (A/D)	Torr		$1 \times 10^{-3} \times \text{FS} \dots 1 \times \text{FS}$	
PCG400	mbar (Torr)		$5 \times 10^{-4} \dots 1500$ ($3.75 \times 10^{-4} \dots 1125$)	
PSG	mbar (Torr)		$5 \times 10^{-4} \dots 1000$ ($3.75 \times 10^{-4} \dots 750$)	
MPG	mbar (Torr)		$5 \times 10^{-9} \dots 1000$ ($3.75 \times 10^{-9} \dots 750$)	
PEG	mbar (Torr)		$1 \times 10^{-9} \dots 1 \times 10^{-2}$ ($7.5 \times 10^{-10} \dots 7.5 \times 10^{-3}$)	
BCG	mbar (Torr)		$5 \times 10^{-10} \dots 1500$ ($3.75 \times 10^{-10} \dots 1125$)	
BPG	mbar (Torr)		$5 \times 10^{-10} \dots 1000$ ($3.75 \times 10^{-10} \dots 750$)	
HPG	mbar (Torr)		$2 \times 10^{-6} \dots 1000$ ($1.5 \times 10^{-6} \dots 750$)	
BAG	mbar (Torr)	$2 \times 10^{-10} \dots 1 \times 10^{-1}$ $(1.5 \times 10^{-10} \dots 7.5 \times 10^{-2})$	–	–
Measurement unit (selectable)		mbar, Torr, Pascal, micron		
Setpoints				
Setpoint relays		1	4	6
Channel assignment		1	1 or 2	1/2 or 3
Adjustment range		Sensor dependent		
Hysteresis		adjustable		
Relay contact		potential free change over contact		
Contact rating	V AC / A V DC / A	30 / 1 60 / 0.5	30 / 1 60 / 0.5	30 / 1 60 / 0.5
Connector		D-Sub, 9 pin, male	D-Sub, 25 pin, female	D-Sub, 25 pin, female
Analog output				
Range		0 ... 10.3 Volt, sensor analog output signal		
Programmable analog output		–	1	1
Connector		D-Sub, 9 pin, male	D-Sub, 9 pin, male	D-Sub, 9 pin, male
Interface (digital)				
Connector		RS 232 C D-Sub, 9 pin, female	RS 232 C D-Sub, 9 pin, female	RS 232 C D-Sub, 9 pin, female
Power				
Supply	V	90 ... 250	90 ... 250	90 ... 250
Frequency	Hz	50 ... 60	50 ... 60	50 ... 60
Consumption	W	≤ 30	≤ 45	≤ 65
Temperature				
Operation (ambient)	°C	5 ... 50	5 ... 50	5 ... 50

Dimensions

VGC401

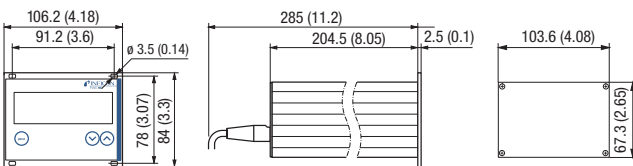

VGC402 / VGC403

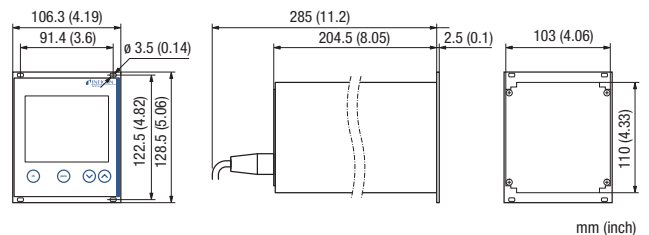

mm (inch)

Vacuum Switch

VSA100A

The pressure switch VSA100A is used as a safety switch in vacuum systems. For example, to automatically interrupt the gas supply when venting vacuum systems with a purge gas at a pressure of 6 mbar below atmospheric pressure.

At a differential pressure of 6 mbar resp. return switching pressure of 3 mbar below atmospheric pressure, an elastic diaphragm actuates a changeover contact which in turn may be used to switch directly any ancillary equipment.

The electrical connections are protected by a plastic cover.



Advantages

- Reliable and budget-priced vacuum switch
- Long service life
- Rugged design
- Easy to integrate
- IP 44 protection
- Can be connected to a programmable control

Applications

- Control of load lock chambers
- Safety shutdown of vacuum systems

Ordering Information

Type	VSA100-A
DN 16 ISO-KF, complete with 3 m (9.9 ft) cable	399-001

VSA100A - continued

Specifications

Switching pressure	mbar	6 ±2 (below atmosphere)
Back switching	mbar	3 ±2 (below atmosphere)
Operating pressure (absolute)	bar	<2
Helium permeation	mbar l/s	<10 ⁻⁶
Leak rate	mbar l/s	<5 x 10 ⁻⁸
Temperature		
Operation	°C	0 ... +85
Storage	°C	-20 ... +85
Switching contacts (gold plated)		Change over contact
Voltage max.	VDC/VAC	24/24
Current max.	mA	30 (24 VDC) / 100 (24 VAC)
Load min.	mA	1
Electrical connector		Cable, bare wire
Cable length, standard	m (ft)	3 (9.9)
Vacuum connection		DN 16 ISO-KF
Protective type		IP 44
Mounting orientation		vertical (standing)
Internal volume	cm ³ (inch ³)	2 (0.122)
Materials exposed to vacuum		Stainless steel 1.4305, EPDM, PTFE (Teflon)
Weight	g	315

Technical Note: Due to the diaphragm material used (EPDM), the Vacuum Switch VSA100A is not suited for applications in which the process gas contains large quantities of helium. The leak rate of the diaphragm for helium is >10⁻⁶ mbar l/s.

Dimensions

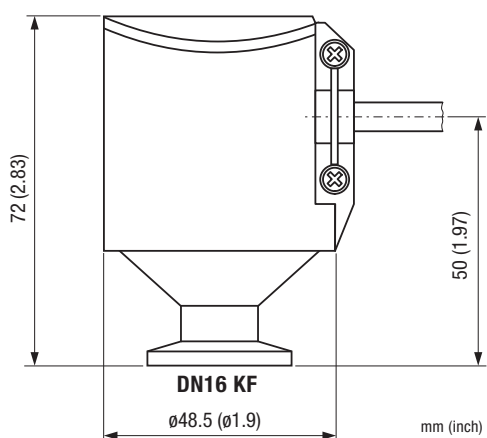

Vacuum Switch

VSC150A

The pressure switch VSA100A is used as a safety switch in vacuum systems. For example, to automatically interrupt the gas supply when venting vacuum systems with a purge gas at a pressure of 6 mbar below atmospheric pressure.

At a differential pressure of 6 mbar, and a return switching pressure of 3 mbar below atmospheric pressure, an elastic diaphragm actuates a changeover contact which in turn may be used to switch directly any ancillary equipment.

The electrical connections are protected by a plastic cover.



Advantages

- High switching accuracy (± 0.1 mbar)
- Stable long term operating characteristics
- Rugged, corrosion protected design
- Increased switching capability when using switching amplifier
- Switching contacts (normally closed) in the reference chamber and thus protected against process media
- Adapter available for differential pressure measurement

Applications

- Pressure switch or differential pressure switch to control valves, pumps, power supplies
- Load lock chambers
- Process chambers

Ordering Information

Type	VSC150
DN 16 ISO-KF	399-005

Accessories

SV Switching Amplifier	399-008
Pressure Switch Adjustment	399-006
Differential Pressure Adapter	399-007

VSC150A - continued

Specifications

			VSC150 Vacuum Switch
Switching range	mbar		0.5 ... 2000
Response sensitivity	mbar		0.1
Overload limit	mbar		3000
Switching hysteresis	mbar		0.5
Temperature			
Operation (ambient)	°C		5 ... 90
Storage	°C		-20 ... 70
Bakeout (max. 8 h)	°C		120
Coefficient of switch point	%/K of switching value		0.4
Vacuum connection			DN 16 ISO-KF
Electrical connection			Protected plug (DIN 43650)
Switch			n.c.
Switching voltage	V		24
Switching current	mA		10
Contact resistance			1
Protection category			IP 65
Materials in contact with the medium			
Sensing volume			Stainless steel 1.4301, 1.4401, 1.4310, 1.3541, FPM75
Reference volume			Stainless steel 1.4301, 1.4401, 1.3541, glass, gold
Sensing volume ¹⁾	cm ³		≈4
Reference volume	cm ³		≈20
Weight	kg		1.3

¹⁾ Including connection port.

Specifications

			SV Switching Amplifier
Mains supply (selectable)	V		110 ... 130, 220 ... 240
Mains frequency	Hz		50 / 60
Power consumption	VA		3
Output relay			
Switching voltage	V		250
Switching current	A		5
Switching capacity	VA		500
Response time	ms		30
Release time	ms		7
Control circuit	V / mA		24 / 10
Operation temperature	°C		5 ... 50
Weight	kg		0.36

VSC150A - continued

Dimensions

VSC150 Vacuum Switch

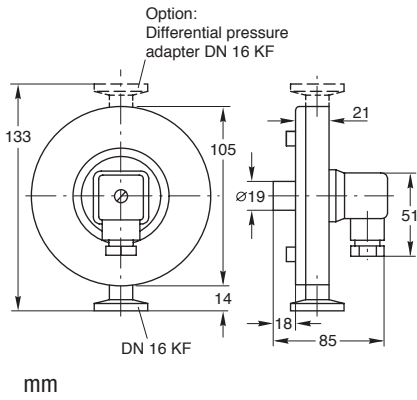

SV Switching Amplifier

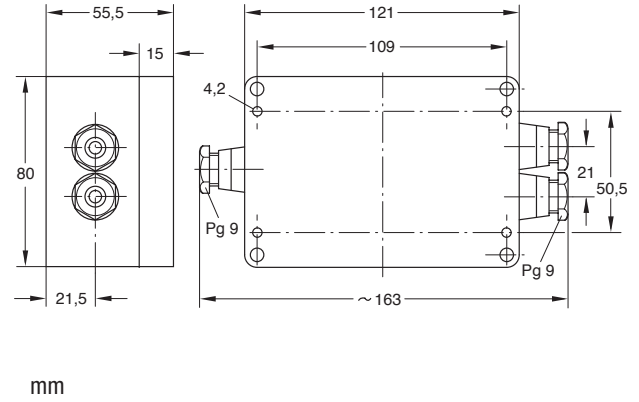

Calibration Service

Vacuum Gauges

INFICON offers calibration services for vacuum gauges. A DKD calibration certificate or a factory calibration certificate can be issued. Calibration to other standards (e.g. NIST) is available upon request.

Advantages

- Known deviation to calibration standards
- Controlled quality over time

Applications

- Reference to standard is required
- Reference for customer in-house calibration service of vacuum gauges

DKD CALIBRATION

The German Calibration Service (DKD) ensures traceability of industrial measurements and testing to national calibration standards. It is run jointly by the Federal Institution for Physics and Technology (PTB), the Industry, the Federal Minister for Economics and the Western European Metrology Club (WEMC).

The transfer standards employed in the DKD calibration facility are checked regularly (recalibrated) by the PTB.

FACTORY CALIBRATION

Factory calibrations are run with standards which have not been calibrated directly at the PTB; instead the transfer standards of the DKD calibration service are used. Thus traceability to national standards is ensured in both cases.

OTHER CALIBRATIONS

NIST Calibration available upon request. Call for pricing and availability.

Ordering Information

Calibration Service	DKD Calibration	Factory Calibration
Calibration range		
to 10 ⁻³ mbar / Torr	398-900	398-910
to 10 ⁻⁵ mbar / Torr	398-901	398-911
to 10 ⁻⁷ mbar / Torr	398-902	398-912



Vacuum Feedthroughs

VACUUM FEEDTHROUGHS

Rotary Feedthroughs ISO-KF / ISO-K

FRH DN 16 - DN 63	B1
-------------------------	----

Rotary Feedthroughs CF

FRU DN 16 - DN 40	B3
-------------------------	----

Rotary/Linear Motion Feedthroughs ISO-KF

FCH DN 16 - DN 40	B5
-------------------------	----

Linear Motion Feedthroughs CF

FPU DN 16 - DN 40	B7
-------------------------	----

Electrical Feedthroughs

DN 16 ISO-KF	B9
DN 40 ISO KF	B11
DN 16 CF	B13
DN 40 CF	B15
DN 40 ISO KF	B17

Coaxial Feedthroughs ISO-KF / CF-F

BNC / MHV DN 16 - 40	B19
----------------------------	-----

Vacuum Feedthroughs

METAL-CERAMIC CONNECTIONS	B21
---------------------------------	-----

Liquid Feedthroughs ISO-KF / CF-F

DN 40	B23
-------------	-----

Viewports

DN 25 - DN 50 ISO-KF	B25
DN 63 - DN 160 ISO-K	B27
DN 16 - DN 160 CF	B29
DN 63 - DN 160 ISO-F	B31

Vacuum Feedthroughs

VACUUM BALL BEARINGS	B33
LUBRICANTS AND SEALING MATERIALS	B35

Rotary Feedthroughs ISO-KF / ISO-K

FRH DN 16 – DN 63

Properties

- For transmitting high torque
- With FPM shaft seal and ball bearings



Selection Data

Vacuum connection	DN 16 ISO-KF	DN 25 ISO-KF	DN 40 ISO-KF	DN 63 ISO-K	
Feedthrough/seal	FPM	FPM	FPM	FPM	
Shaft measure	mm	Ø5	Ø8	Ø12	Ø20

Ordering Information

Type	FRH016-H	FRH025-H	FRH040-H	FRH063-H
Part No.	214-300	214-302	214-304	214-306 ²⁾

Specifications

Transferable torque	Nm	1.5	6	25	100
Rotational speed ¹⁾	rpm	1500	1000	750	500
Idling torque under vacuum	Ncm	≤ 3	≤ 4	≤ 5	≤ 10
Starting torque under vacuum	Ncm	≤ 6	≤ 8	≤ 10	≤ 20
Shaft load vacuum sided					
Radial force	N	60	150	250	500
Axial force	N	30	50	60	100
Service life	Revolutions	20 000 000	20 000 000	20 000 000	10 000 000
Tightness, static	mbar l/s	1 x 10 ⁻⁹	1 x 10 ⁻⁹	1 x 10 ⁻⁹	1 x 10 ⁻⁹
Pressure (absolute)	1 x 10 ⁻⁹ mbar ... 1 bar				
Operating temperature	°C	50			
Bakeout temperature	°C	110			
Materials exposed to process media	stainless steel 420/1.4021 aluminum 6063/3.2315 elastomer FPM				
Weight	kg	0.1	0.2	0.6	2

¹⁾ When a reduced service life is acceptable, the rotation can be increased by up to a factor of two

²⁾ Centering ring / CR/aluminum Part No. 212-251 / FPM / stainless steel Part No. 212-281 not included in delivery

FRH DN 16 – DN 63 - continued

Dimensions

FRH016-H

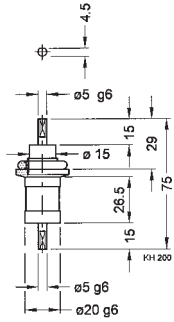

FRH025-H

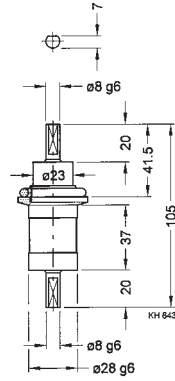

FRH040-H

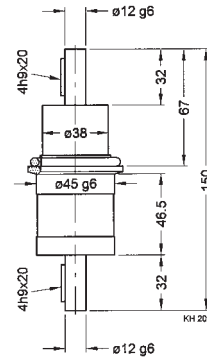

FRH063-H

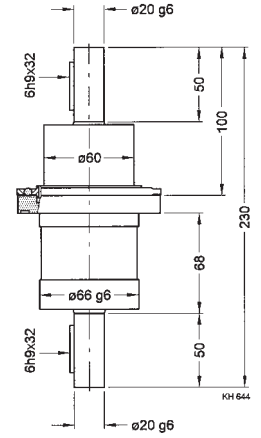

Rotary Feedthroughs CF

FRU DN 16 – DN 40

Properties

- Bellow sealed
- All-metal version
- For very demanding vacuum requirements



Selection Data

Vacuum connection		DN 16 CF-F	DN 40 CF-F	DN 40 CF-F
Feedthrough / seal		bellow	bellow	bellow
Shaft connection	mm	4	8	12

Ordering Information

Type	FRU016-H	FRU040-N	FRU040-L
Part No.	214-310	214-312	214-314

Specifications

Transferable torque				
Dynamic	Nm	0.4	4	10
Dynamic, at 300°C	Nm	0.2	2	2
Static	Nm	0.2	3	5
Rotational speed	rpm	200	1000	500
At max. torque	rpm		500	300
Shaft load vacuum sided				
Radial force	N	10	60	100
Axial force	N	5	20	30
Service life	Revolutions	1 000 000	2 000 000	1 000 000
Scale division	Degree	10	–	–
Tightness	mbar l/s		5 x 10 ⁻¹¹	
Pressure (absolute)			1 x 10 ⁻¹⁰ mbar ... 2 bar	
Operating temperature	°C		300	
Bakeout temperature	°C		300	
Materials exposed to process media		304L/1.4306 304/1.4301 –/2.4360	304L/1.4306 304/1.4301 –/2.4360	304L/1.4306 304/1.4301 303/1.4305
Weight	kg	0.3	1.5	3.0

FRU DN 16 – DN 40 - continued

Dimensions

FRU016-H

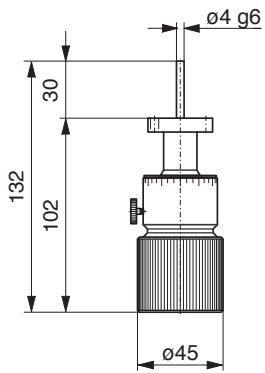

FRU040-N

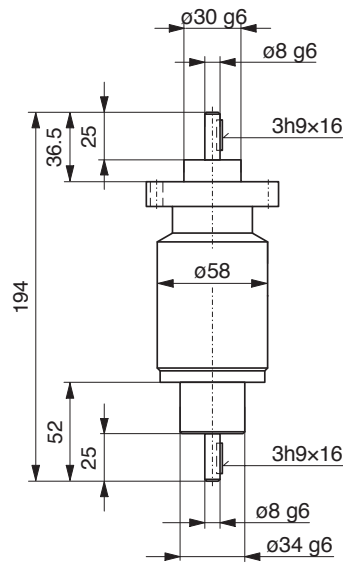

FRU040-L

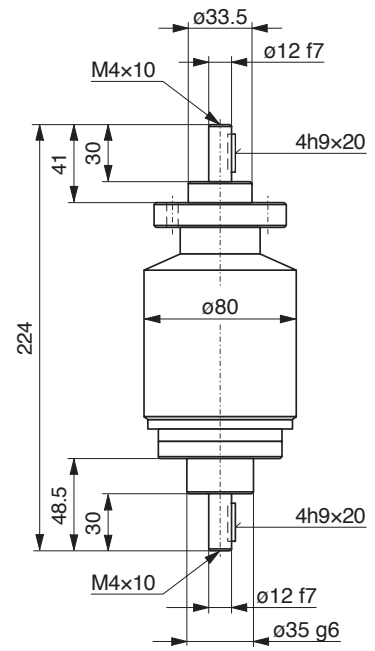

Rotary/Linear Motion Feedthroughs ISO-KF

FCH DN 16 – DN 40

Properties

- Two FPM shaft seals
- Direct push/pull and rotary actuation
- With locking ring and optional anti-rotation device



Selection Data

Vacuum connection	DN 16 ISO-KF	DN 25 ISO-KF	DN 40 ISO-KF
Feedthrough/seal	FPM	FPM	FPM
Shaft connection	M 3 / Ø 5mm	M 4 / Ø 8mm	M 6 / Ø 12mm
Travel	mm	50	100
			150

Ordering Information

Type		FCH016-H	FCH025-H	FCH040-H
Rotary/linear feedthrough	Part No.	214-320	214-322	214-324
Anti-rotation device	Part No.	214-072	214-073	214-074

Specifications

Shaft load				
Radial force at max.travel	N	10	15	30
Torsion torque	Nm	2	8	20
Tightness, static	mbar l/s	1 x 10 ⁻⁹		
Pressure (absolute)		1 x 10 ⁻⁹ mbar ... 1bar		
Operating temperature	°C	50		
Bakeout temperature	°C	110		
Materials exposed to process media		stainless steel 304/1.4301 aluminum 6063/3.2315		
Weight	kg	0.1	0.2	0.3

FCH DN 16 – DN 40 - continued

Dimensions

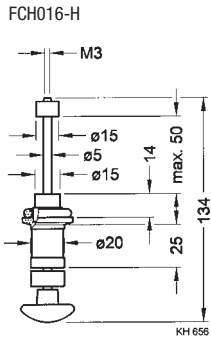

Feedthrough

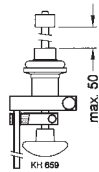

Anti-rotation device

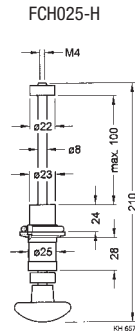

Feedthrough

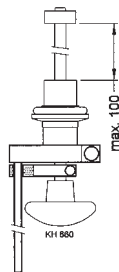

Anti-rotation device

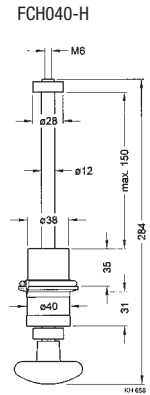

Feedthrough

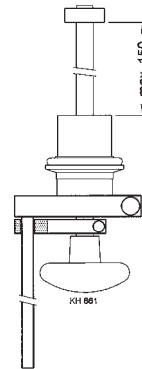

Anti-rotation device

Linear Motion Feedthroughs CF

FPU DN 16 – DN 40

Properties

- With bellows for more demanding vacuum requirements
- Direct push and pull actuation
- High accuracy adjustment using micrometer screw



Selection Data

	DN 16 CF-R	DN 40 CF-R	DN 16 CF-R	DN 40 CF-R
Vacuum connection	DN 16 CF-R	DN 40 CF-R	DN 16 CF-R	DN 40 CF-R
Feedthrough/seal	bellow	bellow	bellow	bellow
Shaft connection	M4x16 mm	M6x10 mm, Ø10 mm	M4x16 mm	M6x10mm, Ø10 mm
Actuator	manual	manual	micrometer screw	micrometer screw
Travel	mm	25	20	50

Ordering Information

Type	FPU016-H	FPU040-H	FPU016-Z	FPU040-Z
Part No.	214-330	214-332	214-334	214-336

Specifications

Travel per revolution	mm			0.5	1
Scale division	mm	5	10	0.01	0.005
Shaft load					
Radial force at max.	N	20	100	20	100
Axial force vacuum	N	85	140	185	440
Axial force against atm	N	100	200	200	500
Torsion torque	Nm	0.2	0.5	0.2	0.5
Tightness	mbar l/s	5 x 10 ⁻¹¹			
Pressure (absolute)		1 x 10 ⁻¹⁰ mbar ... 2 bar			
Bakeout temperature					
Feedthrough	°C	300	300	300	300
Micrometer screw	°C			100	100
Materials exposed to process media					
stainless steel 304L/1.4301 stainless steel 316Ti/1.4571					
Weight	kg	0.15	0.75	0.25	1

FPU DN 16 – DN 40 – continued

Dimensions

FPU016-H

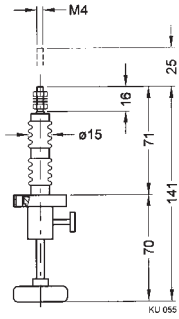

FPU040-H

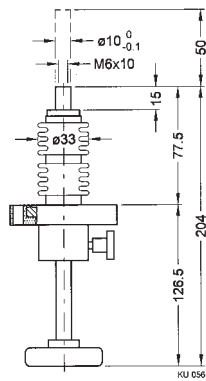

FPU016-Z

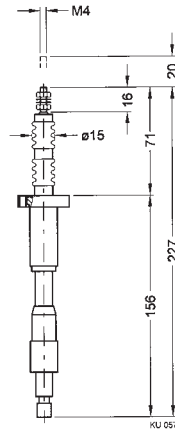

FPU040-Z

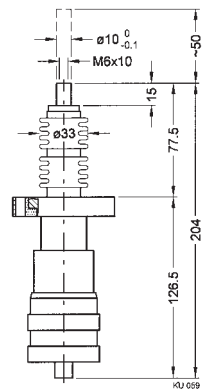

Electrical Feedthroughs

DN 16 ISO-KF



Selection Data

Vacuum connection		DN 16 ISO-KF	DN 16 ISO-KF	DN 16 ISO-KF
Number of feedthroughs		4	9	9
Voltage per pole	V	50	50	50
Current per pole	A	1	2	2

Ordering Information

Feedthrough	214-111	214-112	214-113
Connector: vacuum side	–	–	214-191
Connector: atmospheric side	214-171	214-172	214-172

Specifications

Connection		solder connection connector	solder connection connector	connector connector
Vacuum side				
Atmospheric side				
Diameter of connecting wire	mm	0.6	1.2	1.2
Tightness	mbar l/s	1 x 10 ⁻⁹		
Pressure (absolute)		1 x 10 ⁻⁹ mbar ... 2.5 bar		
Bakeout temperature (feedthrough and connector)	°C	130		
Housing		stainless steel 303/1.4305		
Insulator		PEEK / Araldite		
Seal		FPM		
Contacts (feedthrough and connector)		gold-plated bronze		

DN 16 ISO-KF - continued

Dimensions

214-111

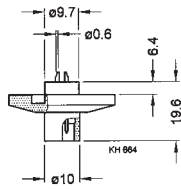

Feedthrough

214-112

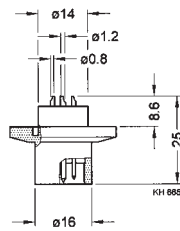

Feedthrough

214-113

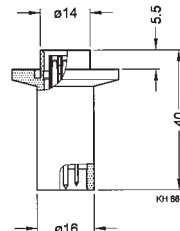

Feedthrough

214-191

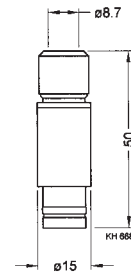

Connector:
vacuum side

214-171

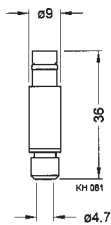

214-172

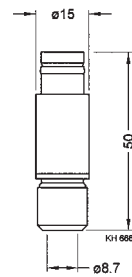

214-172

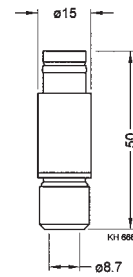

Connector:
air side

Electrical Feedthroughs

DN 40 ISO KF



Selection Data

Vacuum connection		DN 40 ISO - KF	DN 40 ISO - KF	DN 40 ISO - KF	DN 40 ISO - KF
Number of feedthroughs		7	7	4	1
Voltage per pole	V	380	380	800	6000
Current per pole	A	16	16	16	25

Ordering Information

Feedthrough	214-121	214-122	214-123	214-131
Connector: vacuum side	–	214-193	214-194	–
Connector: atmospheric	214-174	214-174	214-175	214-180

Specifications

Connection				
Vacuum side		solder connection	connector	connector
Atmospheric side		connector	connector	connector
Diameter of connecting wire	mm	1.8	1.8	2.5
Test voltage	kV/HZ	–	–	–
Pressure (absolute)		1 x 10 ⁻⁸ mbar ... 2.5bar		
Bakeout temperature (feedthrough and connector)	°C	130		
Housing		stainless steel 303/1.4305		
Insulator		PTFE/Araldite		
Seal		FPM		
Contact (feedthrough and connector)		gold-plated bronze	gold-plated bronze	gold-plated bronze
				nickel-plated brass

DN 40 ISO KF - continued

Dimensions

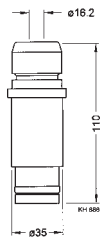
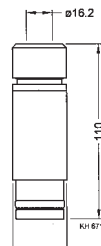
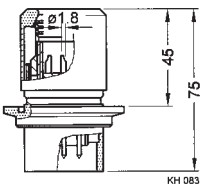
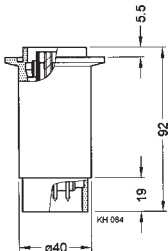
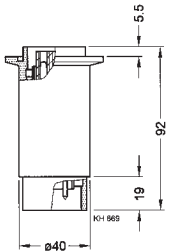
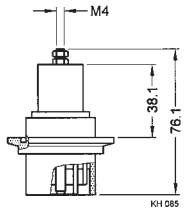
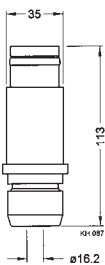
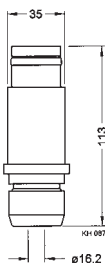
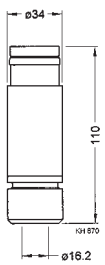
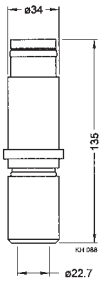
	<p>214-193</p>  <p>Connector: vacuum side</p>	<p>214-194</p>  <p>Connector: vacuum side</p>	
<p>214-121</p>  <p>Feedthrough</p>	<p>214-122</p>  <p>Feedthrough</p>	<p>214-123</p>  <p>Feedthrough</p>	<p>214-131</p>  <p>Feedthrough</p>
<p>214-174</p>  <p>Connector: air side</p>	<p>214-174</p>  <p>Connector: air side</p>	<p>214-175</p>  <p>Connector: air side</p>	<p>214-180</p>  <p>Connector: air side</p>

Electrical Feedthroughs

DN 16 CF

Selection Data

Vacuum connection		DN 16 CF-F
Number of feedthroughs		1
Voltage per pole	kV	0.3
Current per pole	A	120

Ordering Information

Feedthrough	214-126
Connection piece: vacuum side	214-195
Connector: atmospheric side	214-176

Specifications

Bakeout temperature	°C	400
Tightness	mbar l/s	5×10^{-11}
Pressure (absolute)		1×10^{-10} mbar ... 2 bar
Flange		stainless steel 304/1.4301
Conductor		OF-copper 2.0040
Insulator		aluminum oxide ceramic Al ₂ O ₃
Weight		0.15
Connection piece: vacuum side		2
Current max.		100
Bakeout temperature	°C	400
Material		stainless steel 304/1.4301
Connector: atmospheric side	Pieces	2
Current max.	A	100
Insulated, for use up to	VAC/VDC	not insulated
Bakeout temperature	°C	150
Contact		silver-plated brass

DN 16 CF - continued

Dimensions

214-126

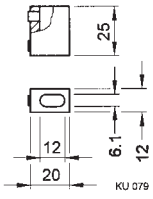

214-195

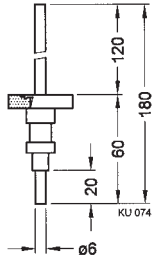

214-176

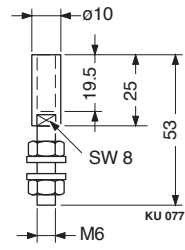

Electrical Feedthroughs

DN 40 CF



Selection Data

Vacuum connection		DN 40 CF-F	DN 40 CF-F	DN 40 CF-F	DN 40 CF-F	DN 40 CF-F
Number of feedthroughs		1	1	2	4	9
Voltage per pole	kV	0.3	1	0.3	1	1
Current per pole	A	70	200/1000 ¹⁾	70	8	8

¹⁾ With water-cooling

Ordering Information

Feedthrough	214-136	214-127	214-128	214-116	214-117
Connection piece: vacuum side	214-195	214-196	214-195	214-192	214-198
Connector: atmospheric side	214-176	214-177	214-176	214-173	214-181
Connector: atm. side, H₂O cooled	–	214-178	–	–	–

Specifications

Bakeout temperature	°C	400			
Tightness	mbar l/s	5 x 10 ⁻¹¹			
Pressure (absolute)		1 x 10 ⁻¹⁰ mbar ... 2 bar			
Flange		304/1.4301	304/1.4301	304/1.4301	304/1.4301
Conductor		OFC 2.0040	OFC 2.0040	OFC 2.0040	304/1.4301
Insulator		Al ₂ O ₃	Al ₂ O ₃	Al ₂ O ₃	Al ₂ O ₃
Weight		0.15	0.5	0.45	0.3
Connection piece: vacuum side		2	1	2	5
Current	A	20	1000 ¹⁾	100	12
Bakeout temperature	°C	400	400	400	400
Material		304/1.4301	2.0061	304/1.4301	304/1.4301
Connector: atmospheric side	Pieces	2	1	2	5
Current max.	A	100	250	100	25
Insulated, for use up to	VAC/VDC	not insulated	30/60	30/60	30/60
Bakeout temperature	°C	150	150	50	50
Contact		silver-plated brass	silver-plated brass	silver-plated brass	gold-plated brass

DN 40 CF - continued

Dimensions

214-195

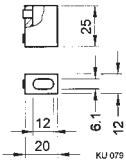

Connector vacuum side

214-196

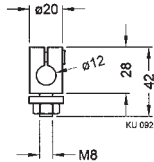

Connector vacuum side

214-195

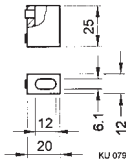

Connector vacuum side

214-192



Connector vacuum side

214-198



Connector vacuum side

214-136

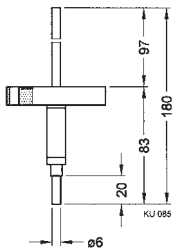

Feedthrough

214-127

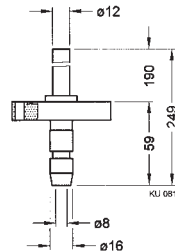

Feedthrough

214-128

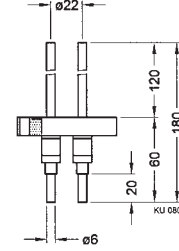

Feedthrough

214-116

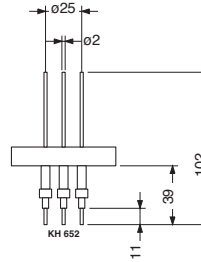

Feedthrough

214-117

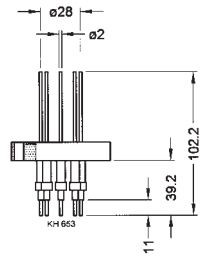

Feedthrough

214-176

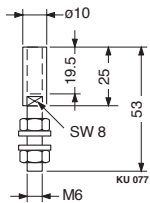

Connector air side

214-177

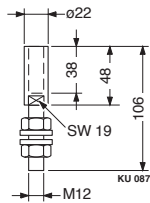

Connector air side

214-176

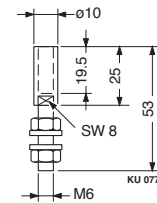

Connector air side

214-173

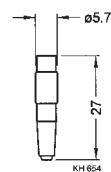

Connector air side
With soldered joint

214-181

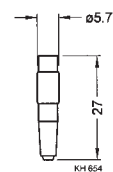

Connector air side
With soldered joint

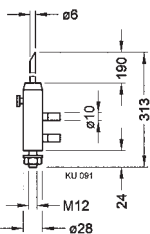

With water-proof ¹⁾		
Current max.	A	1000
Not insulated, for use up to		24
Bakeout temperature	°C	120
Contact	silver-plated brass	

High Current Feedthrough

DN 40 ISO KF

Properties

- ◆ Selection of three electrodes
- ◆ Slide into mounted feedthrough
- ◆ Current connection with water cooling



Selection Data

Vacuum connection		DN 40 ISO-KF
Number of feedthroughs		1
Voltage	V	100
Current	A	250/1500 ¹⁾

¹⁾ With water cooling

Ordering Information

Feedthrough with O-ring KF40	214-141
Current connection with water cooling ²⁾	214-145
Straight electrode	214-142
Angle electrode	214-143

²⁾ Not insulated

Specifications

Tightness	mbar l/s	1 x 10 ⁻⁹
Pressure (absolute)		1 x 10 ⁻⁸ mbar ... 2.5 bar (max. 10 bar with external centering ring)
Bakeout temperature	°C	110
Housing		aluminum 6063/3.2315
Insulator		thermoplast and thermoset
Seal		FPM

DN 40 ISO KF - continued

Dimensions

214-141

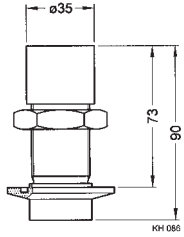

Feedthrough

214-145

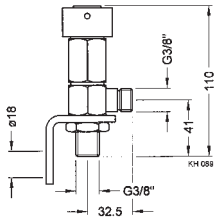

Current connection
with water cooling
copper/brass

214-142

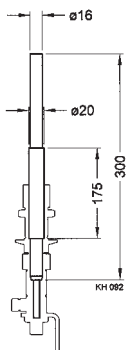

Electrodes copper/brass

214-143

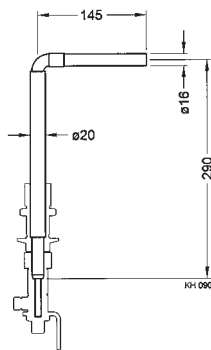

Electrodes copper/brass

Coaxial Feedthroughs ISO-KF / CF-F

BNC / MHV DN 16 – 40

Properties

- Based on MIL-C-39012A
- Voltage up to 5 kV DC
- With atmospheric connector



Selection Data

Vacuum connection	DN 16 ISO-KF	DN 16 ISO-KF	DN 16 CF-F	DN 16 CF-F	DN 40 CF-F
Number of feedthroughs	1	1	1	1	3

Ordering Information

Type	BNC	MHV	BNC	MHV	MHV
Part No.	214-151	214-152	214-155	214-156	214-157

Specifications

Voltage						
AC, 50 Hz	kV	0.35	3.5	0.35	3.5	3.5
DC	kV	0.5	5	0.5	5	5
Current	A	3	3	3	3	3
Frequency	MHz	150		150		
Impedance		50-60		50-60		
Insulation resistance at 20°C		10 ¹⁰	10 ¹⁰	10 ¹⁰	10 ¹⁰	10 ¹⁰
Tightness	mbar l/s	1 x 10 ⁻⁹	1 x 10 ⁻⁹	1 x 10 ⁻¹⁰	1 x 10 ⁻¹⁰	1 x 10 ⁻¹⁰
Pressure (absolute) ¹⁾		1 x 10 ⁻⁸ mbar to 2.5 bar	1 x 10 ⁻⁸ mbar to 2.5 bar	1 x 10 ⁻¹⁰ mbar to 10 bar	1 x 10 ⁻¹⁰ mbar to 10 bar	1 x 10 ⁻¹⁰ mbar to 10 bar
Housing, flange, conductor		stainless steel	stainless steel	stainless steel	stainless steel	stainless steel
Feedthrough, seal		Al ₂ O ₃	Al ₂ O ₃	Al ₂ O ₃	Al ₂ O ₃	Al ₂ O ₃
Bakeout temperature						
With connector	°C	50	50	50	50	50
Without connector	°C	200	200	400	400	400
Standart connection						
Atmospheric connector		UG 88/U	UG 932/U	UG 88/U	UG 932/U	UG 932/U
Cable		RG 58/U	RG 59/U	RB 58/U	RG 59/U	RG 59/U
Weight	kg	0.1	0.1	0.14	0.14	0.5

¹⁾ Pressure at 400°C : 2 bar

BNC / MHV DN 16 - 40 - continued

Dimensions

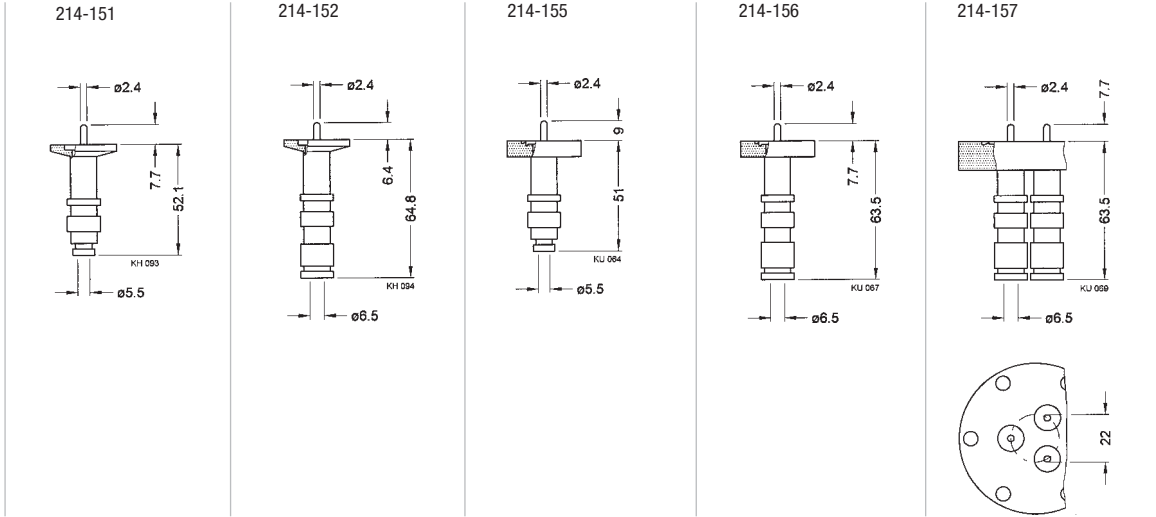

Vacuum Feedthroughs

METAL-CERAMIC CONNECTIONS

Properties

- High grade materials allow repeated bakings up to 400°C



Selection Data

Voltage ¹⁾	3 kV	2 kV	5 kV	10 kV
-----------------------	------	------	------	-------

Ordering Information

Part No.	214-161	214-162	214-163	214-164
----------	---------	---------	---------	---------

Specifications

Insulator		Al ₂ O ₃	Al ₂ O ₃	Al ₂ O ₃	Al ₂ O ₃
Connection					
a		Fe-Ni	Fe-Ni	Fe-Ni	Fe-Ni
b		Fe-Ni	stainless steel 304/1.4301	stainless steel 304/1.4301	stainless steel 304/1.4301
Bakeout temperature	°C	400	400	400	400
Tightness	mbar l/s	5 x 10 ⁻¹¹	5 x 10 ⁻¹¹	5 x 10 ⁻¹¹	5 x 10 ⁻¹¹
Weight	g	5	12	25	90

¹⁾ Based on VDE 0110 for air and surface-leakage in atmosphere on both sides.
Higher values up to factor two are admissible in pressures <10⁻⁴ mbar.

METAL-CERAMIC CONNECTIONS - continued

Dimensions

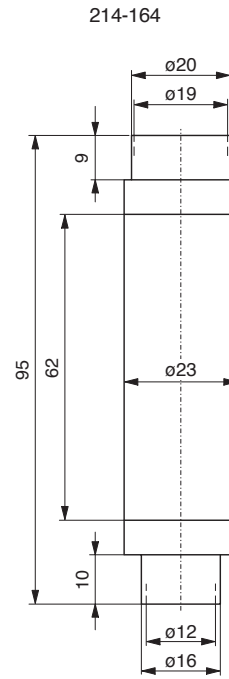
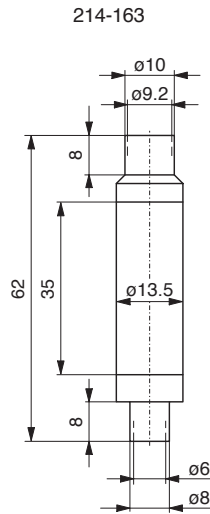
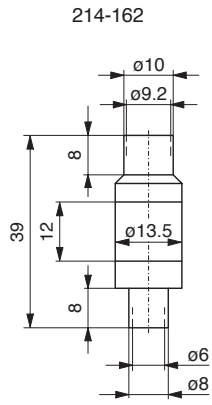
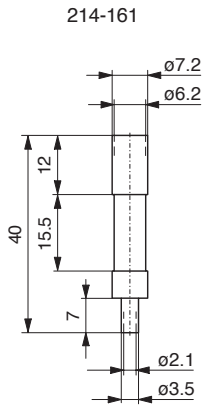

Liquid Feedthroughs ISO-KF / CF-F

DN 40

Properties

- For H₂O and LN₂
- Thermally insulated
- Specially suited for very hot and very cold applications



Selection Data

Vacuum connection		DN 40 ISO-KF	DN 40 CF-F
Feedthrough/seal		welded	welded
Tube dimensions	mm	Ø 8 x 1	Ø 8 x 1
Number of tubes		2	2

Ordering Information

Part No.	214-101	214-102
----------	---------	---------

Specifications

Tightness	mbar l/s	1 x 10 ⁻⁹	1 x 10 ⁻¹⁰
Pressure		10 ⁻⁸ mbar ... 10 bar	10 ⁻⁹ mbar ... 10 bar
Temperature range	°C	-200 ... +150	-200 ... +400
Material		stainless steel 304/1.4301	stainless steel 304/1.4301
Weight	kg	0.3	0.4

DN 40 - continued

Dimensions

214-101

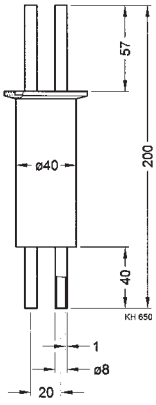

214-102

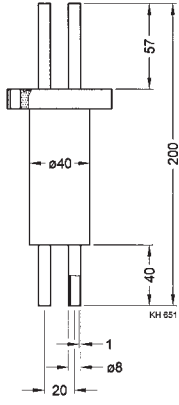

Viewports

DN 25 – DN 50 ISO-KF

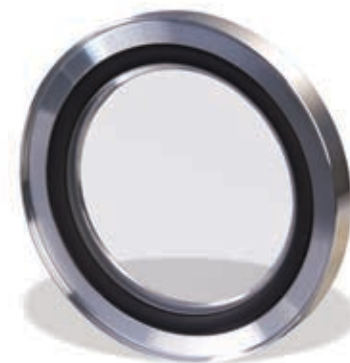
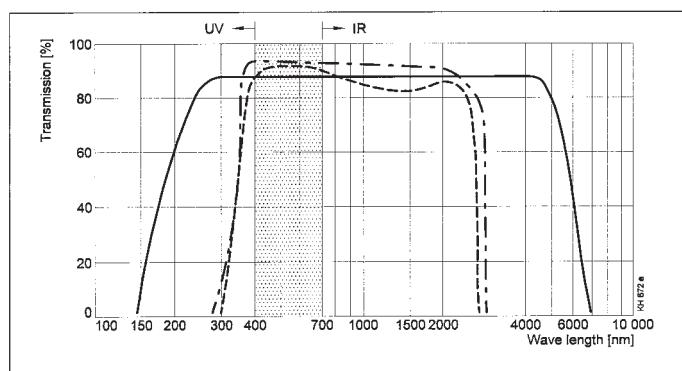

Average transmittance curve

- Sapphire
- . - Kodial
- - - Borosilicate

Properties

- Wide viewing angle

Selection Data

Vacuum connection	DN 25 ISO-KF	DN 40 ISO-KF	DN 50 ISO-KF
Window		borosilicate glass	
Seal		FPM	
Flange		aluminum 6082/3.2315	
Bakeout temperature	°C	150	

Ordering Information

Part No.	214-003	214-004	214-005
----------	---------	---------	---------

Specifications

Tightness	mbar l/s	1 x 10 ⁻⁹	
Pressure (absolute)		1 x 10 ⁻⁸ mbar ... 4 bar	
Max. at 150°C	bar	3	
Window thickness	mm	3.8	
Weight	g	20	30
			40

DN 25 - DN 50 ISO-KF - continued

Dimensions

214-003

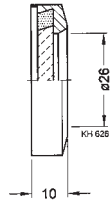

214-004

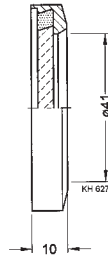

214-005

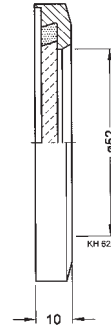

Mounting

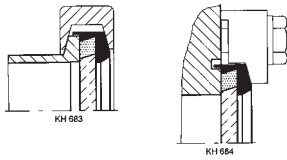

Claws, screws and clamping ring not included

Viewports

DN 63 – DN 160 ISO-K

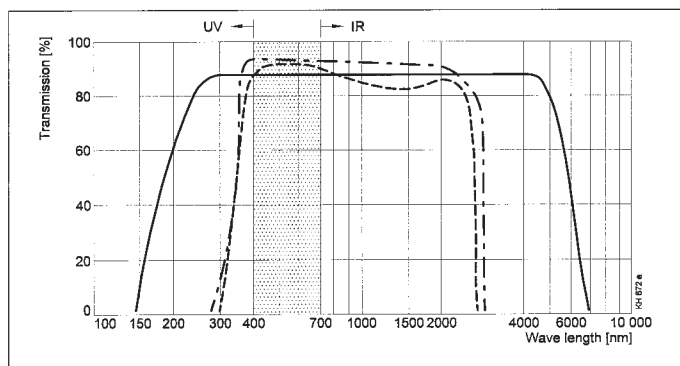

Average transmittance curve

- Sapphire
- . - Kodial
- - - Borosilicate



Properties

- Wide viewing angle

Selection Data

Vacuum connection	DN 63 ISO-K	DN 100 ISO-K	DN 160 ISO-K
Window		borosilicate glass	
Seal		FPM	
Flange		aluminum 6082/3.2315	
Bakeout temperature	°C	150	

Ordering Information

Part No.	214-006	214-007	214-008
----------	---------	---------	---------

Specifications

Tightness	mbar l/s	1 x 10 ⁻⁹		
Pressure (absolute)		1 x 10 ⁻⁸ mbar ... 2 bar		
Max. at 150°C	bar	1		
Window thickness	mm	6	8	10
Weight	kg	0.2	0.3	0.4

¹⁾ Claws not included

DN 63 – DN 160 ISO-K - continued

Dimensions

214-006

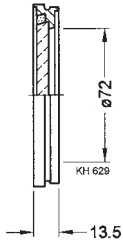

214-007

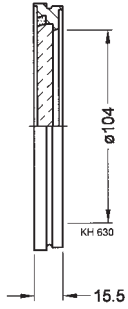

214-008

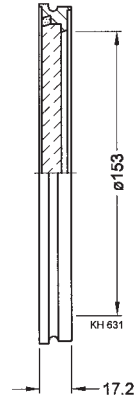

Mounting

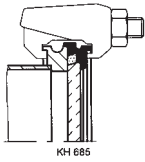

Viewports

DN 16 – DN 160 CF

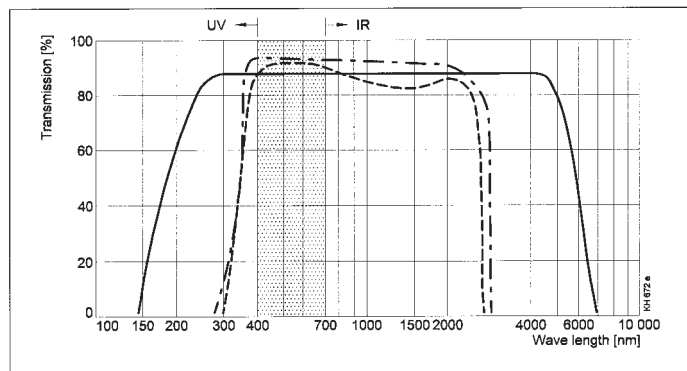

Average transmittance curve

- Sapphire
- - - Kodial
- . - Borosilicate



Properties

- Protection window
- With Fe-Ni alloy as transition material

Selection Data

Vacuum connection	DN 16 CF-F	DN 40 CF-F	DN 40 CF-F	DN 63 CF-F	DN 100 CF-F	DN 160 CF-F
Window	kodial glass	kodial glass	sapphire glass	kodial glass	kodial glass	kodial glass
Seal	iron/nickel					
Flange	stainless steel 304/1.4301					
Bakeout temperature	°C 400					

Ordering Information

Viewport	214-021	214-022	214-032	214-023	214-024	214-025
Bolt set	213-416	standard	standard	standard	standard	standard

Specifications

Tightness	mbar l/s	5 x 10 ⁻¹¹					
Pressure (absolute)		1 x 10 ⁻¹⁰					
Min.	mbar	1					
Max.	bar	2					
Max. at 400°C	bar	1					
Window thickness	mm	1.5	3	3	3.5	6	8
Weight	kg	0.04	0.24	0.35	0.85	1.4	2.8

DN 16 – DN 160 CF – continued

Dimensions

214-006

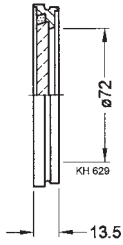

214-007

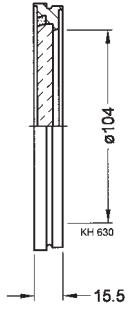

214-008

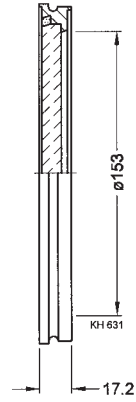

Mounting

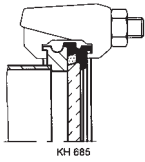

Viewports

DN 63 – DN 160 ISO-F

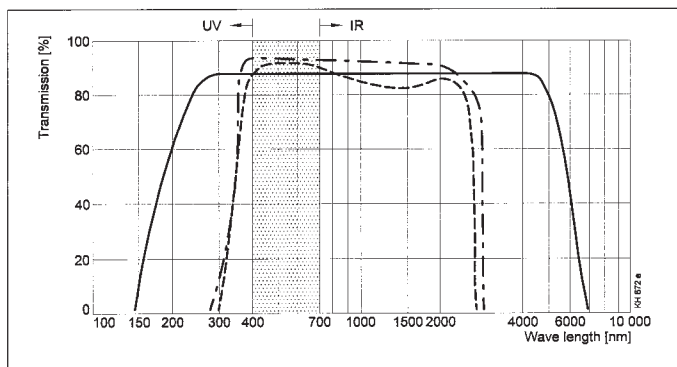

Average transmittance curve

- Sapphire
- - - Kodial
- . - Borosilicate



Properties

- Wide viewing angle

Selection Data

Vacuum connection	DN 63 ISO-F	DN 100 ISO-F	DN 160 ISO-F
Window		borosilicate glass	
Seal		FPM	
Flange		black anodized aluminum 6063/3.2315	
Centering ring		aluminum 6063/3.2315	
Snap ring		stainless steel 304/1.4301	
Bakeout temperature	°C	150	

Ordering Information

Viewport ¹⁾	214-016	214-017	214-018
Protective glass, 5 pcs.	214-046	214-047	214-048

¹⁾ Claws, bolts, nuts and washer included

Specifications

Tightness	mbar l/s	1 x 10 ⁻⁹		
Pressure (absolute)		1 x 10 ⁻⁸ mbar ... 2 bar		
Max. at 150°C	bar	1		
Window thickness	mm	7.5	11	15
Protective glass thickness	mm	2.5	2.5	2.5
Weight	kg	0.8	1.4	3

DN 63 – DN 160 ISO-F – continued

Dimensions

214-006

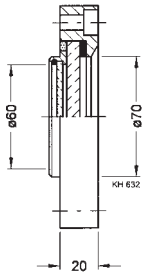

214-007

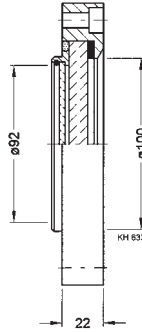

214-008

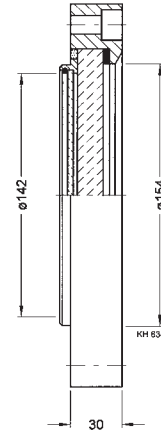

Mounting

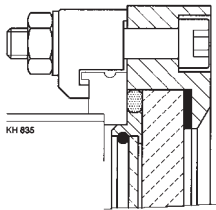

Vacuum Feedthroughs

VACUUM BALL BEARINGS

Properties

- Specially suited for clean vacuum applications and extreme residual gas requirements
- With shields (non-rubbing seals)
- With dry lubrication
- Bearing clearance



Selection Data

Service life ¹⁾ (revolutions)		> 20 Mio.
Pressure (absolute)	mbar	$1 \times 10^{-12} \dots 1 \times 10^{-2}$
Operating temperature ²⁾	°C	-200 ... +300
Material		stainless steel 440C/1.3543, 304/1.4301

Ordering Information

Type	624	605	626	608	6000	6001
Part No.	214-211	214-212	214-213	214-214	214-215	214-216

Specifications

Rotational speed at								
		624	605	626	608	6000	6001	
20°C	rpm	5000	4000	3000	2500	2000	1500	
300°C	rpm	1500	1500	1000	800	500	300	
Load capacity ³⁾	Static C ₀	N	400	400	800	1000	1500	2000
	Dynamic C	N	50	50	100	150	200	250
	Axial load		<<C	<<C	<<C	<<C	<<C	<<C
Fit according to ISO		G6 / f6	G6 / f6	G6 / f6	G6 / f6	G6 / f6	G6 / f6	
Weight	g	3	4	8	13	20	25	

¹⁾ At half load and > 1000/min

²⁾ At -200°C reduction of tenacity

³⁾ At 20°C; half value at 300°C

VACUUM BALL BEARINGS - continued

Dimensions

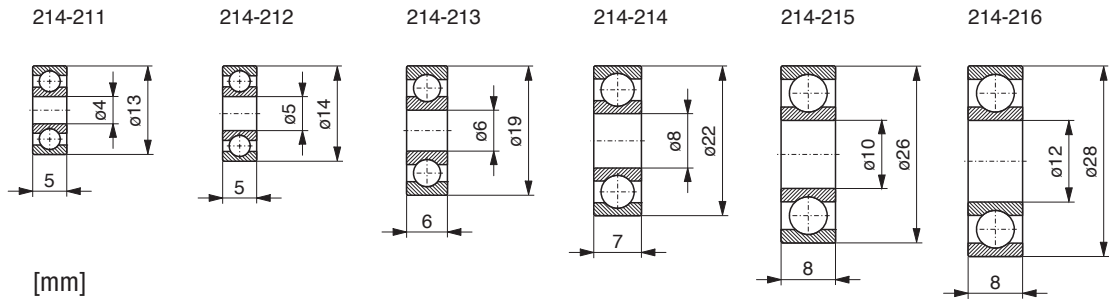

Vacuum Feedthroughs

LUBRICANTS AND SEALING MATERIALS



High Temperature Lubricant

- Prevents seizing of stainless steel screw connections at atmosphere even at high temperatures
- Remains fully effective for at least 10 bakeout cycles

Selection Data

Temperature resistance	1000°C
In packages of	28 g

Ordering Information

Type	C 100
Part No.	214-231

Sealing Material

- For sealing small leaks

Selection Data

Temperature resistance	°C	-40 - 200	350
Version		Paste	Spray
In packages of	g	200	170

Ordering Information

Type	Rhodosil 340	Sprayseal
Part No.	214-233	214-234

LUBRICANTS AND SEALING MATERIALS - continued

Vacuum Grease/Oil

- For sliding elastomer seals
- Low vapor pressure
- Good adhesiveness

Selection Data

Temperature resistance	°C	10 - 30	-40 - 200	-20 - 200	-60 - 300	-60 - 300
Vapor pressure at 20°C	mbar	<10 ⁻⁸	<5 x 10 ⁻⁷	< 10 ⁻¹²	< 10 ⁻¹²	< 10 ⁻¹²
100°C	mbar		<7 x10 ⁻⁶	< 10 ⁻⁷	< 10 ⁻⁷	< 10 ⁻⁷
In packages of		25 g	50 g	10 g	30 g	10 ml
Material		mineral grease	silicon grease	fluorinated grease	fluorinated grease with MoS ₂	fluorinated oil

Ordering Information

Type	Apezon M	Dow Corning	FU 090	FM 090	OL 090
Part No.	214-236	214-237	214-238	214-239	214-240

Characteristics

Lubricity	very good	good	good	good/very good	good
Resistance to Oxidation		very good	very good	very good	very good
Chemicals		good	very good	very good	very good
Thermal decomposition		very good	good	good	good



Vacuum Valves

VACUUM VALVES

Angle and Inline Valves (VAH, VAP, VAM, VIM)

ISO-KF DN 5 manually, pneumatically, solenoid	C1
---	----

Angle and Inline Valves (VAH, VIH, VAP, VIP)

ISO-KF DN16 - 40 manually.	C4
ISO-KF DN16 - 40 manually (Diaphragm Valves).	C8
ISO-KF DN16 - 40 pneumatically	C10
ISO-KF DN16 - 40 solenoid (VAP, VIP)	C14
ISO-KF DN16 - 40 solenoid (VAM).	C18
ISO-KF DN63 manually, pneumatically	C21
ISO-KF DN100 manually, pneumatically	C24
ISO-KF DN160 pneumatically	C27

Butterfly Valves (VBH, VBP)

ISO-KF DN63 - 160 manually	C29
ISO-KF DN63 - 250 pneumatically	C31

Dosing Valves (MDH)

ISO-KF DN10 manually (coarse gas dosing)	C37
ISO-KF DN16 manually (fine gas dosing / shut-off)	C38

Dosing Systems (VDM, VDE, VCE, VCC, VCA)

All-Metal Dosing Valves and System	C40
Gas Dosing Systems	C43
Solenoid Control Valves	C44

All-Metal Angle Valves (VAH)

CF-R DN16 - 63 manually	C50
-----------------------------------	-----

Venting Valves (VWH, WWM, VIN)

ISO-KF DN10 manually	C52
ISO-KF DN10 solenoid.	C53
ISO-KF DN10 solenoid (power failure)	C55

VACUUM VALVES (continued)

Safety Valves (VSM)

ISO-KF DN16 - 40	C56
ISO-KF DN63 - 100	C56

Pressure Relief Valve (VSA)

ISO-KF DN16	C58
-------------------	-----

Ball Valves

ISO-KF DN10 - 40	C59
------------------------	-----

Angle and Inline Valves (VAH, VAP, VAM, VIM)

DN 5

Manually Actuated

- Angle valve
- Spindle drive

Pneumatically Actuated

- Angle valves
- With and without pilot valve

Solenoid Actuated

- Angle and inline valves



Selection Data

Actuation		manual	pneumatic	el.-pneumatic	solenoid	solenoid	solenoid
Feedthrough		bellows	bellows	bellows	without	without	without
Vacuum connection	mm	Ø5 / M 14 x 1	Ø5 / M 14 x 1	Ø5 / M 14 x 1	Ø5 / M 14 x 1	Ø5 / M 14 x 1	Ø5 / M 14 x 1
Service life ¹⁾	cycles	–	5 Mio	5 Mio	2 Mio	2 Mio	2 Mio
Attributes		angle valve	angle valve w/o pilot valve	angle valve with pilot valve	angle valve	inline valve normally closed	inline valve normally open

¹⁾ Under clean operating conditions

Ordering Information

Type	VAH005-X	VAP005-X	VAP005-X	VAM005-X	VIM005-X	VIM005-Z
Valve / Part No.	250-070	250-040	–	–	–	–
Normally closed	–	–	250-050	250-000	250-010	–
Normally open	–	–	250-060	–	–	250-020

Spare Parts

Seal set	215-373	215-372	215-372	215-371	215-371	215-371
Spare parts set	215-369	215-368	215-368	215-365	215-366	215-367

Connection Elements

Type	Flange DN 10 ISO-KF	For pipe OD 1/4"	For pipe OD 6mm
Part No.	250-080	250-085	250-086

DN 5 – continued

Specifications

Type		VAH005-X manual	VAP005-X pneumatic	VAP005-X el.-pneumatic	VAM005-X solenoid	VIM005-X solenoid	VIM005-Z solenoid
Tightness	mbar l/s	1 x 10 ⁻⁹	1 x 10 ⁻⁹	1 x 10 ⁻⁹	1 x 10 ⁻⁹	1 x 10 ⁻⁹	1 x 10 ⁻⁹
Conductance for air							
Molecular flow	l/s	0.4	0.4	0.4	0.3	0.2	0.2
Laminar flow	l/s	4	4	4	3	2	2
Pressure range (absolute)	mbar ... bar	10 ⁻⁸ ... 4	10 ⁻⁸ ... 4	10 ⁻⁸ ... 4	10 ⁻⁸ ... 10	10 ⁻⁸ ... 10	10 ⁻⁸ ... 10
Pressure difference Δp							
In closing direction	bar	4	3	3	5	5	4
In opening direction	bar	4	3	3	1.5	1.5	2
Opens against Δp ¹⁾	bar	4	3	3	1	1	4
Temperature							
Ambient	°C	5 ²⁾ ... 70	5 ²⁾ ... 80	5 ²⁾ ... 40	5 ²⁾ ... 40	5 ²⁾ ... 40	5 ²⁾ ... 40
Closing time	ms	–	35 / 35	35 / 35	7 / 30	7 / 30	30 / 10
Opening time	ms	–	–	–	–	–	–
Switching frequency	1/min	–	150	150	300	300	300
Degree of protection		–	IP 65	IP 65	IP 65	IP 65	IP 65
Supply voltage/	V DC	–	–	24	24	24	24
Power consumption	W	–	–	1	10	10	10
Materials							
Housing		304/1.4301	304/1.4301	304/1.4301	304/1.4301	304/1.4301	304/1.4301
Actuator		Al & plastic	anodized Al	anodized Al	–	–	–
Bellows		304/1.4301	304/1.4301	304/1.4301	–	–	–
Valve plate		304/1.4301	304/1.4301	304/1.4301	–	–	–
Guiding tube		–	–	–	303/1.4105	303/1.4105	303/1.4105
Armature		–	–	–	303/1.4105	303/1.4105	303/1.4105
Seals		FPM	FPM	FPM	FPM	FPM	FPM
Weight	kg	0.15	0.20	0.20	0.26	0.28	0.30

¹⁾ Compressed air: overpressure 4 bar

²⁾ –15°C, if the ambience is free of condensable gases

Dimensions

VAH005-X



VAP005-X



VAP005-X



VAM005-X

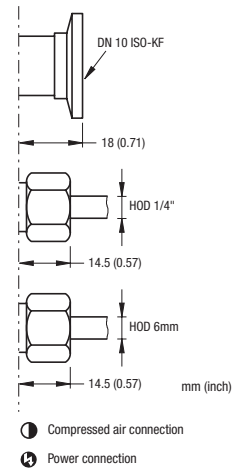
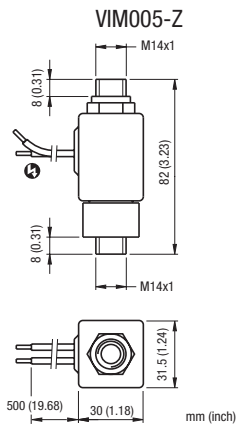
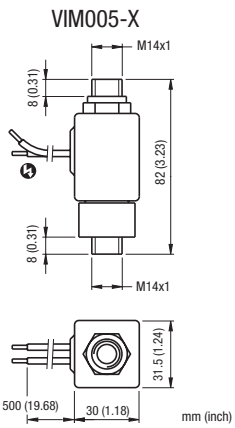

Angle and Inline Valves (VAH, VIH) Manually Actuated

VAH016 ... 040-A/X

VIH016 ... 040-X

The INFICON ISO-KF valve line, VAH / VIH016 ... 040-A/X performs as a gauge isolation, bypass, roughing or venting valve and is well suited for all general high vacuum and semiconductor processes. The improved industrial design results in a rugged, compact, easy to operate valve. The visual position indicator shows the open / close status of the valve for clear understanding of valve status. The extremely long service life and easy to maintain design results in a highly reliable valve with low cost of ownership. The new line is compatible with the current INFICON VAH / VIH016 ... 040-A/X valve line.



Advantages

- Ergonomically designed knob for secure grip
- Fast open / close actuation with one 130° turn; or a soft continuously variable actuation for controlled venting / pumping of vacuum systems
- Low operating force required, even if the valve is opened against vacuum
- Drive locks into final open / close position
- Visual position indicator, standard
- 316L stainless steel bellows
- Easy maintenance, fast bellows and seal replacement
- High conductance for fast pump down or venting
- High differential pressure resistance
- FPM sealing standard, other sealing materials available upon request
- High purity aluminum or stainless steel housing

VAH016 ... 040-A/X

VIH016 ... 040-X - continued

Selection Data

Vacuum connection	DN 16 ISO-KF			DN 25 ISO-KF		DN 40 ISO-KF	
Aluminum housing	AISI/DIN	-/EN AW-6082		-/EN AW-6082		-/EN AW-6082	
Stainless steel housing	AISI/DIN		304/1.4301		304/1.4301		304/1.4301

Ordering Information

Angle Valve

Type	VAH016-A	VAH016-X	VAH025-A	VAH025-X	VAH040-A	VAH040-X
	253-200	253-245	253-300	253-345	253-400	253-445

Inline Valve

Type	VIH016-A	VIH016-X	VIH025-A	VIH025-X	VIH040-A	VIH040-X
	—	253-265	—	253-365	—	253-465

Specifications

Cycle life	Cycles	10000		10000		10000	
Conductance for molecular flow							
Angle valve	l/s	5		14		45	
Inline Valve	l/s	2.5		7		20	
Tightness	mbar l/s	1×10^{-9}		1×10^{-9}		1×10^{-9}	
Operating pressure min. / max.	mbar / bar	$1 \times 10^{-8} / 2$		$1 \times 10^{-8} / 2$		$1 \times 10^{-8} / 1.5$	
Pressure, max. (absolute)	bar	4		4		4	
Pressure difference							
In closing direction	bar	4		4		2	
In opening direction	bar	2		2		1.5	
Ambiance temperature	°C	0 ... +50		0 ... +50		0 ... +50	
Mounting orientation		any		any		any	
Seals		FPM		FPM		FPM	
Weight							
Angle valve	kg	0.31	0.34	0.42	0.49	0.85	0.96
Inline valve	kg		0.71		1.09		1.83

Spare Parts

Vacuum connection	DN 16 ISO-KF	DN 25 ISO-KF	DN 40 ISO-KF
Seal kit	299-001	299-006	299-011
O-rings for one valve			
Bellows cpl.	299-002	299-007	299-012
Bellows & seal kit			

VAH016 ... 040-A/X

VIH016 ... 040-X - continued

Dimensions Angle Valve

Aluminum housing

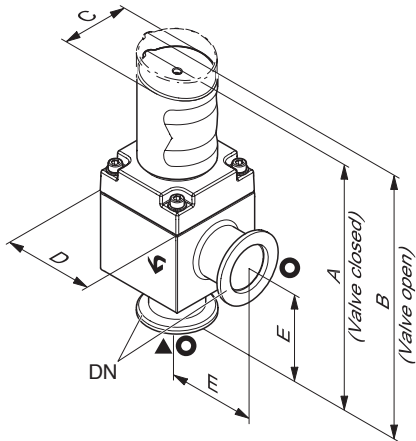

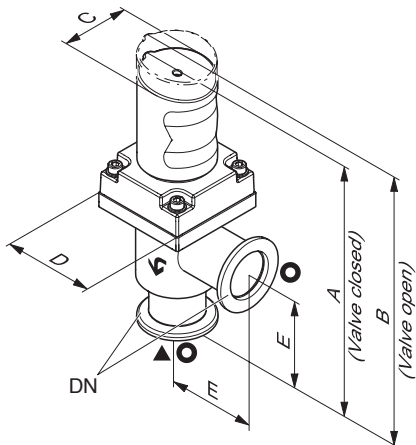

DN	A	B	C	D	E
DN 16 ISO-KF	141.3	149.5	39.6	45	40
DN 25 ISO-KF	145.3	155.7	39.6	54	50
DN 40 ISO-KF	186.2	201.4	50	69	65

Stainless steel housing



DN	A	B	C	D	E
DN 16 ISO-KF	143.9	152.1	39.6	45	40
DN 25 ISO-KF	148.7	159.1	39.6	54	50
DN 40 ISO-KF	189.2	204.4	50	69	65

-  Protective lid
-  Valve seat site
-  Flow direction

VAH016 ... 040-A/X

VIH016 ... 040-X - continued

Dimensions Inline Valve

Stainless steel housing

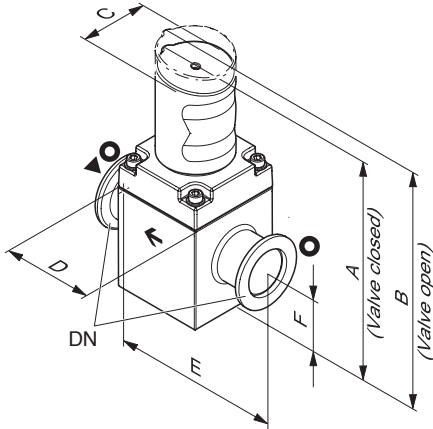

DN	A	B	C	D	E	F
DN 16 ISO-KF	125.4	133.6	39.6	45	80	20
DN 25 ISO-KF	132	142.4	39.6	54	100	31.8
DN 40 ISO-KF	166.5	181.7	50	69	130	40.8

- Protective lid
- ▼ Valve seat site
- Flow direction

Diaphragm Valves Manually Actuated

VIH016 ... 040-AD

The INFICON ISO-KF diaphragm valve line, VIH016 ... 040-AD performs as a gauge isolation, roughing or venting valve. The manual spindle drive allows easy gas dosing. The robust and rugged industrial design is well suited for gases and liquids and is resistant to contamination.



Advantages

- Spindle drive for controlled venting and easy dosing
- Low operating force required
- Visual position indicator
- FPM diaphragm sealing; other sealing materials on request
- Aluminum inline housing EN AW-6082
- Easy maintenance, fast diaphragm seal replacement
- Small footprint and easy system integration

Ordering Information Selection Data

Type	VIH016-AD	VIH025-AD	VIH040-AD
	253-481	253-482	253-483

Spare Parts

Diaphragm (1 piece)	299-031	299-032	299-033
---------------------	---------	---------	---------

VIH016 ... 040-AD - continued

Specifications

		VIH016-AD	VIH025-AD	VIH040-AD
Vacuum connection		DN 16 ISO-KF	DN 25 ISO-KF	DN 40 ISO-KF
Cycle life	Cycles	>10000	>10000	>10000
Conductance for molecular flow	l/s	2	5	17
Tightness	mbar l/s	1×10^{-9}	1×10^{-9}	1×10^{-9}
Operating pressure min. / max.	mbar / bar	1×10^{-7} / 5	1×10^{-7} / 5	1×10^{-7} / 5
Pressure, max. (absolute)	bar	5	5	5
Ambiance temperature	°C	0 ... +50	0 ... +50	0 ... +50
Mounting orientation		any	any	any
Diaphragm		FPM	FPM	FPM
Weight	kg	0.16	0.5	1.2

Dimensions

VIH016-AD, VIH025-AD

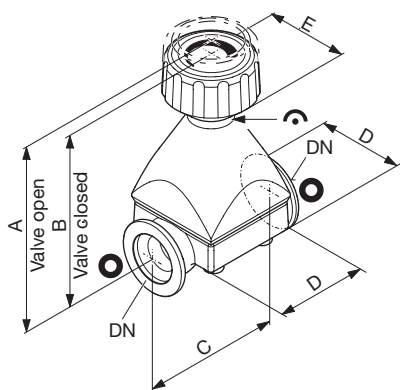

- Protective lid
- ◐ Visual position indicator

[mm]

DN	A	B	C	D	E	F
DN 16 ISO-KF	66	62	52	32.5	29.5	–
DN 25 ISO-KF	111	101	80	54	47	–
DN 40 ISO-KF	148.5	134.5	105	75	69.5	80

VIH040-AD

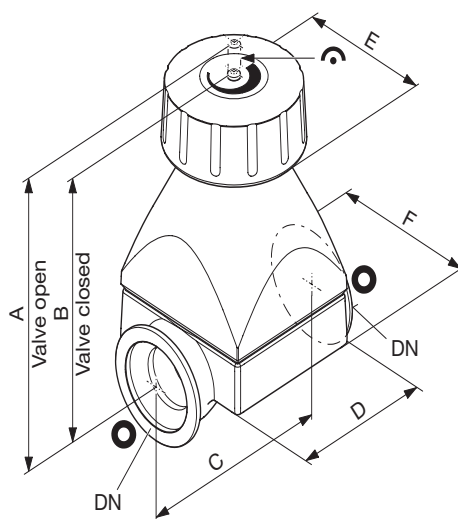

Angle and Inline Valves (VAP, VIP) Pneumatically Actuated

VAP016 ... 040-A/X

VIP016 ... 040-X

The INFICON ISO-KF valve line, VAP / VIP016 ... 040-A/X performs as a gauge isolation, bypass, roughing or venting valve and is well suited for all general high vacuum and semiconductor processes. The improved industrial design results in a rugged, compact, highly reliable valve with a low cost of ownership. The All-in-One concept means the valve is fast and easy to install and the pilot valve and electrical position indicator are integrated for convenient “plug and play” use. The proven All-in-One design and extremely long service lifetime makes this valve easy to maintain. The new line is fully compatible with the current INFICON VAP / VIP016 ... 040-A/X valve line.



Advantages

- All-in-One design for fast and easy installation; one connector for the pilot valve and electrical position indicator for easy “plug and play”
- Direct pneumatic actuation or via integrated pilot valve
- Normally open and normally closed versions available
- Electrical and visual position indicator standard
- 10 million cycle 316L stainless steel bellows
- Easy maintenance, fast bellows and seal replacement
- Fast opening and closing time
- High conductance for fast pump down or venting
- High differential pressure resistance
- FPM sealing standard, other sealing materials available upon request
- High purity aluminum or stainless steel housing

Ordering Information Selection Data

Vacuum connection	DN 16 ISO-KF		DN 25 ISO-KF		DN 40 ISO-KF	
Aluminum housing	AISI/DIN	-/EN AW-6082	-/EN AW-6082		-/EN AW-6082	
Stainless steel housing	AISI/DIN	304/1.4301	304/1.4301		304/1.4301	

VAP016 ... 040-A/X

VIP016 ... 040-X - continued

Ordering Information

Angle Valve

Type	VAP016-A	VAP016-X	VAP025-A	VAP025-X	VAP040-A	VAP040-X
Without pilot valve, with position indicator	253-210	253-250	253-310	253-350	253-410	253-450
With pilot valve, with position indicator						
24 V DC (n.c.)	253-211	253-251	253-311	253-351	253-411	253-451
24 V AC (n.c.)	253-212	253-252	253-312	253-352	253-412	253-452
100 ... 115 V AC (n.c.)	253-213	253-253	253-313	253-353	253-413	253-453
200 ... 230 V AC (n.c.)	253-214	253-254	253-314	253-354	253-414	253-454
24 V DC normally open	253-215	253-255	253-315	253-355	253-415	253-455

Inline Valve

Type	VIP016-A	VIP016-X	VIP025-A	VIP025-X	VIP040-A	VIP040-X
Without pilot valve, with position indicator	—	253-270	—	253-370	—	253-470
With pilot valve, with position indicator						
24 V DC (n.c.)	—	253-271	—	253-371	—	253-471
24 V AC (n.c.)	—	253-272	—	253-372	—	253-472
100 ... 115 V AC (n.c.)	—	253-273	—	253-373	—	253-473
200 ... 230 V AC (n.c.)	—	253-274	—	253-374	—	253-474
24 V DC normally open	—	253-275	—	253-375	—	253-475

Specifications

Cycle life	Mio cycles	10		10		10	
Conductance for molecular flow							
Angle valve	l/s	5		14		45	
Inline Valve	l/s	2.5		7		20	
Tightness	mbar l/s	1×10^{-9}		1×10^{-9}		1×10^{-9}	
Operating pressure min. / max.	mbar / bar	1×10^{-8} / 2		1×10^{-8} / 2		1×10^{-8} / 2	
Pressure, max. (absolute)	bar	5		5		5	
Pressure difference							
In closing direction	bar	5		5		5	
In opening direction	bar	2		2		2	
Ambiance temperature	°C	0 ... +50		0 ... +50		0 ... +50	
Switching frequency	1/min	100		100		75	
Opening time	ms	100		120		260	
Closing time	ms	100		160		540	
Electrical position indicator							
Rating	V AC / VA / A	250 / 25 / 0.1		250 / 25 / 0.1		250 / 25 / 0.1	
	V DC / W / A	50 / 12.5 / 0.25		50 / 12.5 / 0.25		50 / 12.5 / 0.25	
Compressed air, overpressure	bar	4 ... 8		4 ... 8		4 ... 8	
Piston displacement	cm ³	4		11		35	
Mounting orientation		any		any		any	
Seals		FPM		FPM		FPM	
Weight							
Angle valve	kg	0.49	0.52	0.68	0.75	1.21	1.33
Inline valve	kg		0.89		1.35		2.2

VAP016 ... 040-A/X

VIP016 ... 040-X - continued

Spare Parts

Vacuum connection	DN 16 ISO-KF	DN 25 ISO-KF	DN 40 ISO-KF
Seal kit O-rings for one valve	299-001	299-006	299-011
Bellows cpl. Bellows & seal kit	299-002	299-007	299-012
Cover cpl. Receptacle, visual & electrical position indicator already assembled	299-003	299-008	299-013

Accessories

Vacuum connection	DN 16 ISO-KF	DN 25 ISO-KF	DN 40 ISO-KF
Cable connector right angled	215-165	215-165	215-165

Dimensions Angle Valve

Aluminum housing

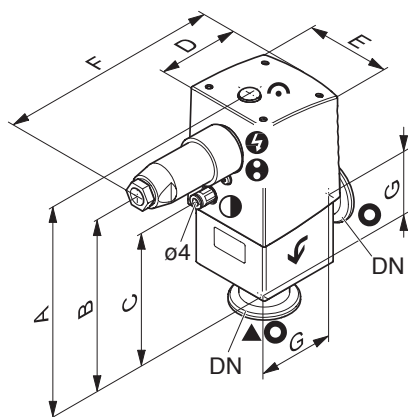

DN	A	B	C	D	E	F	G
DN 16 ISO-KF	142	112.9	75.1	55	51.4	93.2	40
DN 25 ISO-KF	146.9	117.8	79	64.3	60.1	97.8	50
DN 40 ISO-KF	188.8	159.7	114.9	81.3	75.7	105.3	65

-  Compressed air connection
-  Position indicator connection
-  Protective lid
-  Valve seat site
-  Electrical connection
-  Visual position indicator
-  Flow direction

VAP016 ... 040-A/X



VIP016 ... 040-X - continued

Dimensions Angle Valve

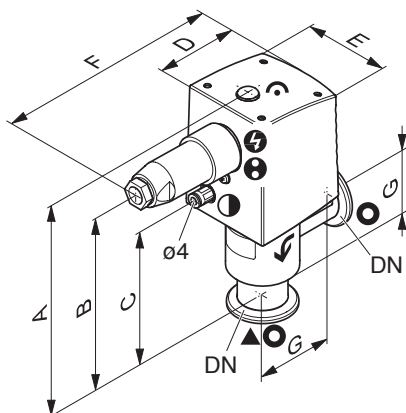
Stainless steel housing



DN	A	B	C	D	E	F	G
DN 16 ISO-KF	144.5	112.9	75.1	55	51.4	93.2	40
DN 25 ISO-KF	150.3	117.8	79	64.3	60.1	97.8	50
DN 40 ISO-KF	191.8	159.7	114.9	81.3	75.7	105.3	65



-  Compressed air connection
-  Position indicator connection
-  Protective lid
-  Valve seat site
-  Electrical connection
-  Visual position indicator
-  Flow direction

Dimensions Inline Valve

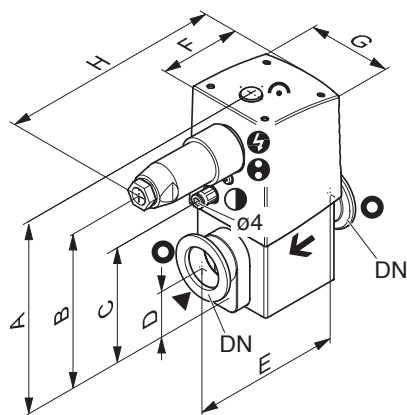
Stainless steel housing



DN	A	B	C	D	E	F	G	H
DN 16 ISO-KF	126.1	97	59.2	20	80	55	51.4	93.2
DN 25 ISO-KF	133.6	104.5	65.7	31.8	100	64.3	60.1	97.8
DN 40 ISO-KF	169.1	140	95.2	40.8	130	81.3	75.7	105.3

-  Compressed air connection
-  Position indicator connection
-  Protective lid
-  Valve seat site
-  Electrical connection
-  Visual position indicator
-  Flow direction

Angle and Inline Valves (VAP, VIP) Pneumatically Actuated

VAP016 ... 040-A/X

VIP016 ... 040-X

The new INFICON ISO-KF valve line, VAP / VIP016 ... 040-A/X performs as a gauge isolation, bypass, roughing or venting valve and is perfectly suited for all general high vacuum and semiconductor processes. The improved industrial design is very robust, compact and highly reliable with a low cost of ownership. This pneumatic actuated valve is designed for system manufacturers who need a compact and space saving valve unit. This valve comes with an outstanding long service lifetime and is very easy to maintain. It is equipped with the same approved high quality components like INFICON is using for its very successful All-in-One concept valve line.



Advantages

- Robust and very compact design
- Visual position indicator, standard
- 10 million cycle 316L stainless steel bellows
- Easy maintenance due to fast bellows and seal replacement
- Fast opening and closing time
- High conductance for fast pump down or venting
- High differential pressure resistance
- FPM sealing standard. Other sealing materials available upon request
- High purity aluminum or stainless steel housing

Order Information Selection Data

Vacuum connection	DN 16 ISO-KF		DN 25 ISO-KF		DN 40 ISO-KF	
Aluminum housing	AISI/DIN	-/EN AW-6060	-/EN AW-6060	304/1.4301	-/EN AW-6060	304/1.4301
Stainless steel housing	AISI/DIN	304/1.4301	304/1.4301	304/1.4301	304/1.4301	304/1.4301

VAP016 ... 040-A/X

VIP016 ... 040-X - continued

Ordering Information

Angle Valve

Type	VAP016-A	VAP016-X	VAP025-A	VAP025-X	VAP040-A	VAP040-X
	253-220	253-260	253-320	253-360	253-420	253-460

Inline Valve

Type	VIP016-A	VIP016-X	VIP025-A	VIP025-X	VIP040-A	VIP040-X
	—	253-280	—	253-380	—	253-480

Specifications

Cycle life	Mio cycles	10		10		10	
Conductance for molecular flow							
Angle valve	l/s	5		14		45	
Inline Valve	l/s	2.5		7		20	
Tightness	mbar l/s	1 x 10 ⁻⁹		1 x 10 ⁻⁹		1 x 10 ⁻⁹	
Operating pressure min. / max.	mbar / bar	1 x 10 ⁻⁸ / 2		1 x 10 ⁻⁸ / 2		1 x 10 ⁻⁸ / 2	
Pressure, max. (absolute)	bar	5		5		5	
Pressure difference							
In closing direction	bar	5		5		5	
In opening direction	bar	2		2		2	
Ambiance temperature	°C	0 ... +50		0 ... +50		0 ... +50	
Bakeout temperature							
Housing	°C	120	150	120	150	120	150
Actuator	°C	120	120	120	120	120	120
Switching frequency	1/min	100		100		75	
Opening time	ms	100		120		260	
Closing time	ms	100		160		540	
Compressed air, overpressure	bar	4 ... 8		4 ... 8		4 ... 8	
Piston displacement	cm ³	4		11		35	
Mounting orientation		any		any		any	
Seals		FPM		FPM		FPM	
Weight							
Angle valve	kg	0.38	0.42	0.57	0.66	1.17	1.28
Inline valve	kg		0.83		1.27		2.48

Spare Parts

Vacuum connection	DN 16 ISO-KF	DN 25 ISO-KF	DN 40 ISO-KF
Seal kit	299-001	299-006	299-011
O-rings for one valve			
Bellows cpl.	299-002	299-007	299-012
Bellows & seal kit			

VAP016 ... 040-A/X

VIP016 ... 040-X - continued

Dimensions Angle Valve

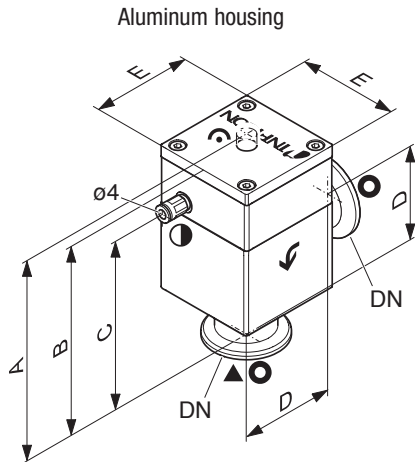

-  Compressed air connection
-  Protective lid
-  Flow direction
-  Valve seat site
-  Visual position indicator

[mm]

DN	A	B	C	D	E
DN 16 ISO-KF	100.5	95.7	75.6	40	45
DN 25 ISO-KF	108.5	102.6	80.6	50	54
DN 40 ISO-KF	150.5	144.7	116.6	65	69

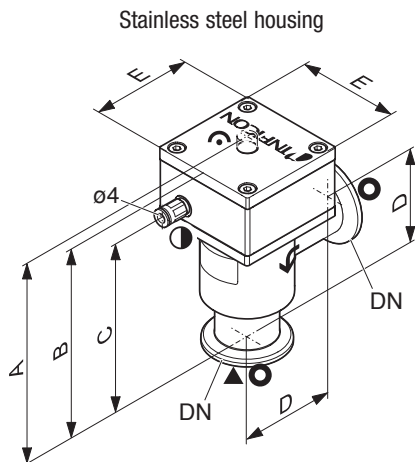

-  Compressed air connection
-  Protective lid
-  Flow direction
-  Valve seat site
-  Visual position indicator

[mm]

DN	A	B	C	D	E
DN 16 ISO-KF	103	98.2	78.1	40	45
DN 25 ISO-KF	112	106	84	50	54
DN 40 ISO-KF	153.5	147.7	119.6	65	69

VAP016 ... 040-A/X

VIP016 ... 040-X - continued

Dimensions Inline Valve

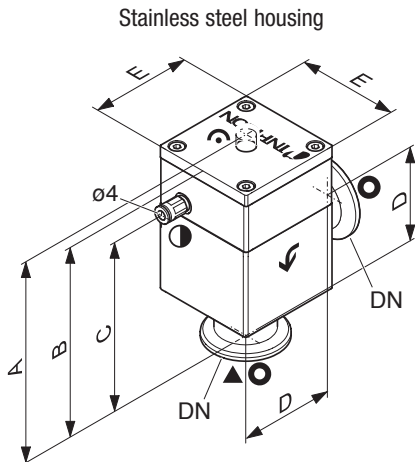

- Compressed air connection
- Protective lid
- ↻ Flow direction
- ▼ Valve seat site
- ◐ Visual position indicator

[mm]

DN	A	B	C	D	E	F
DN 16 ISO-KF	84.5	79.8	59.7	20	80	45
DN 25 ISO-KF	95.5	89.3	67.3	31.8	100	54
DN 40 ISO-KF	131	125	96.9	40.8	130	69

Solenoid Actuated Angle Valves

VAM016 ... 040-A/X

Advantages

- Bellows feedthrough, stainless steel 316L
- Compact design
- Electrical and visual (LED) position indication
- Selectable operating mode
 - Remote control via PLC or PC
 - Local operation
- Wide voltage range
- Easy maintenance, fast bellows and seal replacement
- Fast opening and closing time
- FPM sealing standard, other sealing materials available upon request
- Aluminum or stainless steel housing
- High conductance for fast pump down or venting



Selection Data

Vacuum connection	DN 16 ISO-KF		DN 25 ISO-KF		DN 40 ISO-KF	
Aluminum housing	AISI/DIN	-/EN AW-6060	-/EN AW-6060	304/1.4301	-/EN AW-6060	304/1.4301
Stainless steel housing	AISI/DIN	304/1.4301	304/1.4301			304/1.4301

Ordering Information

Type	VAM016-A	VAM016-X	VAM025-A	VAM025-X	VAM040-A	VAM040-X
Part No.	253-500	253-501	253-502	253-503	253-504	253-505

Spare Parts

Seal kit O-rings for one valve	299-001	299-006	299-011
Bellows cpl. Bellows & seal kit	299-002	299-007	299-012
Electronics cpl.	299-016	299-016	299-016
Linear solenoid cpl.	299-017	299-018	299-019

VAM016 ... 040-A/X - continued

Specifications

Type		VAM016-A	VAM016-X	VAM025-A	VAM025-X	VAM040-A	VAM040-X
Cycle life	Mio cycles	2		2		2	
Conductance for molecular flow	l/s	4		13		35	
Tightness	mbar l/s	1 x 10 ⁻⁹		1 x 10 ⁻⁹		1 x 10 ⁻⁹	
Operating pressure min. / max	mbar / bar	10 ⁻⁸ / 1.3		10 ⁻⁸ / 1.3		10 ⁻⁸ / 1.3	
Pressure max.	bar	3		3		1	
Pressure difference							
In closing direction	bar	1.3		1.3		1.3	
In opening direction	bar	1.3		1.3		1	
Opens to a pressure difference of	bar	1.3		1.3		1.3	
Ambient temperature	°C	0 ... 50		0 ... 50		0 ... 50	
Bakeout temperature							
Housing	°C	120		120		120	
Actuator, idle	°C	50		50		50	
Supply voltage	V	90 ... 264		90 ... 264		90 ... 264	
Frequency	Hz	47 ... 63		47 ... 63		47 ... 63	
Pickup power	W	405		416		367	
Holding power	W	8.1		8.3		7.5	
Power consumption	W	400		400		400	
Closing time	ms	100		120		230	
Opening time	ms	220		220		650	
Dead time	ms	40		140		450	
Switching frequency							
At 40°C	1/min	30		30		30	
At 50°C	1/min	20		20		20	
Control voltage	V DC	15 ... 30		15 ... 30		15 ... 30	
Power consumption	mA	1.5 ... 5		1.5 ... 5		1.5 ... 5	
Position indicator							
Switching voltage	V DC	15 ... 30		15 ... 30		15 ... 30	
Switching current	mA	100		100		100	
Materials							
Housing		EN-AW 6060	1.4301	EN-AW 6060	1.4301	EN-AW 6060	1.4301
Bellows		stainless steel		stainless steel		stainless steel	
Seals		FPM		FPM		FPM	
Degree of protection		IP 54		IP 54		IP 54	
Mounting orientation		any		any		any	
Weight	kg	1.1	1.2	1.9	2.0	4.3	4.4

VAM016 ... 040-A/X - continued

Dimensions

Aluminum housing [mm]

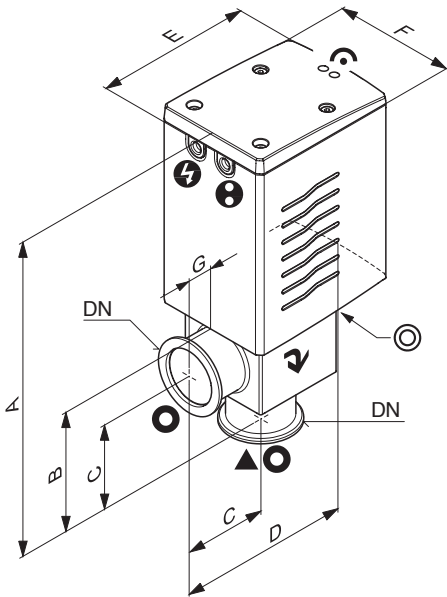

DN	A	B	C	D	E	F	G
DN 16 ISO-KF	170.9	51.4	40	96	86	59	10
DN 25 ISO-KF	193	64.9	50	112.7	97.3	70	15.4
DN 40 ISO-KF	246	92.9	65	139	119.5	90	19.5

- ⊙ Leak detection opening
- ⊕ Position indicator connection
- Protective lid
- ▼ Valve seat site
- ⚡ Electrical connection
- ↻ Visual position indicator
- ↻ Flow direction

Stainless steel housing [mm]

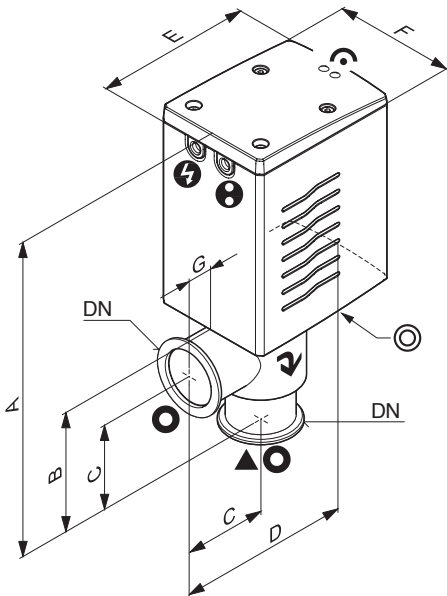

DN	A	B	C	D	E	F	G
DN 16 ISO-KF	172.9	53.4	40	96	86	59	10
DN 25 ISO-KF	196.4	68.3	50	112.7	97.3	70	15.4
DN 40 ISO-KF	249	95.9	65	139	119.5	90	19.5

- ⊙ Leak detection opening
- ⊕ Position indicator connection
- Protective lid
- ▼ Valve seat site
- ⚡ Electrical connection
- ↻ Visual position indicator
- ↻ Flow direction

Angle Valves (VAH, VAP)

DN 63

Manually Actuated

- Spindle drive with hand wheel
- Smooth opening
- Visual position indicator

Pneumatically Actuated

- Visual indication for open and closed position
- Electrical position indicator for open and closed position
- For system manufacturers without pilot valve



Selection Data

Angle valve		DN 63 ISO-K	DN 63 ISO-K
Housing material	AISI/DIN	aluminum -/3.2373	stainless steel 304/1.4301

Ordering Information - Manually Actuated

Type		VAH063-A	VAH063-X
Angle valve	Part No.	250-470	250-475

Spare Parts

Seal set		215-251	215-251
Bellows set for manually actuated valves		215-254	215-254

Specifications - Manually Actuated

Service life	Mio cycles	1.5	1.5
Conductance for molecular flow	l/s	140	140
Tightness	mbar l/s	1 x 10 ⁻⁹	1 x 10 ⁻⁹
Pressure absolute, min. / max.	mbar / bar	10 ⁻⁸ / 1,5	10 ⁻⁸ / 1,5
Pressure resistance	bar (abs.)	4	4
Differential pressure in closing / opening direction	bar	1.5 / 1.5	1.5 / 1.5
Opens to a pressure difference of	bar	1.5	1.5
Ambient temperature	°C	5 – 60	5 – 60
Mounting orientation		any	any
Seals		FPM	FPM
Weight	kg	3.6	6.5

DN 63 - continued

Selection Data

Angle valve		DN 63 ISO-K	DN 63 ISO-K
Housing material	AISI/DIN	aluminum —/3.2373	stainless steel 304/1.4301

Ordering Information - Pneumatically Actuated

Type		VAP063-A	VAP063-X
Angle valve w/o pilot valve, with position indicator		250-404	250-414
Valve with pilot valve, with position indicator			
24 V DC	Part No.	250-400	250-410
24 V AC	Part No.	250-401	250-411
100 – 115 V AC	Part No.	250-402	250-412
200 – 240 V AC	Part No.	250-403	250-413

Spare Parts

Seal set	215-521	215-251
Bellows set for pneumatically actuated valves	215-253	215-253

Specifications - Pneumatically Actuated

Service life	Mio cycles	1.5	1.5
Conductance for molecular flow	l/s	140	140
Tightness	mbar l/s	1 x 10 ⁻⁹	1 x 10 ⁻⁹
Pressure, absolute, min. / max.	mbar / bar	10 ⁻⁸ / 1,5	10 ⁻⁸ / 1,5
Pressure resistance	bar (abs.)	4	4
Differential pressure in closing / opening direction	bar	1.5 / 1.5	1.5 / 1.5
Opens to a pressure difference of	bar	1.5	1.5
Ambient temperature	°C	5 – 60	5 – 60
Switching frequency	1/min	60	60
Closing time	ms	300	300
Opening time	ms	300	300
Electrical position indicator load capacity	VAC / A	250 / 0.125	250 / 0.125
	VDC / A	50 / 0.25	50 / 0.25
Compressed air, overpressure	bar	4 – 8	4 – 8
Air cylinder volume	cm ³	75	75
Mounting orientation		any	any
Seals		FPM	FPM
Weight	kg	4.0	6.8

Dimensions - Manually Actuated

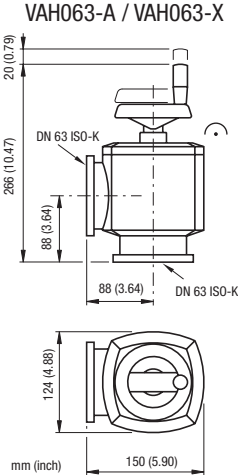

Dimensions - Pneumatically Actuated

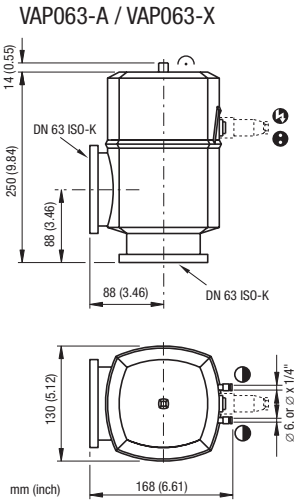

Angle valve with and without pilot valve,
with position indicator

Angle Valves (VAH, VAP)

DN 100

Manually Actuated

- Bellows feedthrough
- Spindle drive with hand wheel
- Smooth opening
- Visual position indication

Pneumatically Actuated

- Bellows feedthrough
- Visual indication of the open and closed position
- Electrical position indicator for open and closed position
- For system manufacturers without pilot valve



Selection Data

Angle valve		DN 100 ISO-K	DN 100 ISO-K
Housing material	AISI(AA)/DIN	aluminum - / 3.2373	stainless steel 303 / 1.4305

Ordering Information - Manually Actuated

Type	VAH100-A	VAH100-X
Part No.	250-480	250-485

Spare Parts

Seal set	215-271	215-271
Bellows set for manually actuated valves	215-274	215-274

Specifications - Manually Actuated

Service life	Mio cycles	1.5	1.5
Conductance for molecular flow	l/s	330	330
Tightness	mbar l/s	1 x 10 ⁻⁹	1 x 10 ⁻⁹
Pressure absolute, min. / max.	mbar / bar	10 ⁻⁸ / 1,5	10 ⁻⁸ / 1,5
Pressure resistance	bar (abs.)	4	4
Differential pressure in closing / opening direction	bar	1.5 / 1.5	1.5 / 1.5
Opens to a pressure difference of	bar	1.5	1.5
Ambient temperature	°C	5 – 60	5 – 60
Mounting orientation		any	any
Seals		FPM	FPM
Weight	kg	6.1	11.1

DN 100 – continued

Selection Data

Angle valve		DN 100 ISO-K	DN 100 ISO-K —
Housing material	AISI (AA) /DIN	aluminum - / 3.2373	stainless steel 303 / 1.4305

Ordering Information - Pneumatically Actuated

Type	VAP100-A	VAP100-X
Angle valve w/o pilot valve, with position indicator	250-424	250-434
Valve with pilot valve, with position indicator		
24 V DC	Part No. 250-420	250-430
24 V AC	Part No. 250-421	250-431
100 – 115 V AC	Part No. 250-422	250-432
200 – 240 V AC	Part No. 250-423	250-433

Spare Parts

Seal set	215-571	215-271
Bellows set for pneumatically actuated valves	215-273	215-273

Specifications - Pneumatically Actuated

Service life	Mio cycles	1.5	1.5
Conductance for molecular flow	l/s	330	330
Tightness	mbar l/s	1 x 10 ⁻⁹	1 x 10 ⁻⁹
Pressure, absolute, min. / max.	mbar / bar	10 ⁻³ / 1,5	10 ⁻³ / 1,5
Resistance to pressure	bar (abs.)	4	4
Differential pressure in closing / opening direction	bar	1.5 / 1.5	1.5 / 1.5
Opens to a pressure difference of	bar	1.5	1.5
Ambient Temperature	°C	5 ... 60	5 ... 60
Switching frequency	1/min	60	60
Closing time	ms	400	400
Opening time	ms	400	400
Electrical position indicator, load capacity	VAC / A	250 / 0.125	250 / 0.125
	VDC / A	50 / 0.25	50 / 0.25
Compressed air, overpressure	bar	4 – 8	4 – 8
Air cylinder volume	cm ³	195	195
Mounting orientation		any	any
Seals		FPM	FPM
Weight	kg	6.7	11.7

DN 100 - continued

Dimensions - Manually Actuated

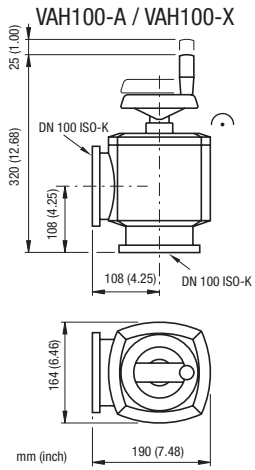

Dimensions - Pneumatically Actuated

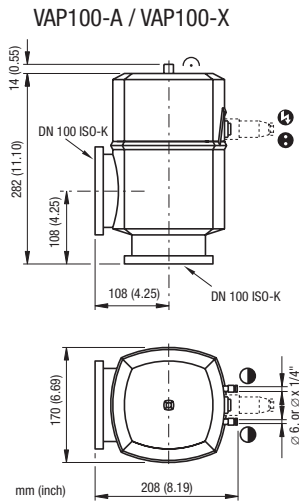

Angle valve with and without pilot valve,
with position indicator

Angle Valves (VAP)

DN 160

Advantages

- Visual indication for open and closed position
- Electrical position indicator for open and closed position
- For system manufacturers without pilot valve



Selection Data

Angle valve		DN 160 ISO-K
Housing material	AA/DIN	aluminum -/3.2373

Ordering Information

Type		VAP160-A
Angle valve w/o pilot valve, with position indicator		250-444
Valve with pilot valve, with position indicator		
24 V DC	Part No.	250-440
24 V AC	Part No.	250-441
100 – 115 V AC	Part No.	250-442
200 – 240 V AC	Part No.	250-443

Spare Parts

Seal set		215-591
Bellows set for pneumatically actuated valves		215-293

Specifications

Service life	Mio cycles	1.5
Conductance for molecular flow	l/s	800
Tightness	mbar l/s	1×10^{-9}
Pressure, absolute, min. / max.	mbar / bar	10^{-3} / 1,5
Pressure resistance	bar (abs.)	4
Differential pressure in closing / opening direction	bar	1.5 / 1.5
Opens to a pressure difference of	bar	1.5
Ambient Temperature	°C	5 – 60
Switching frequency	1/min	40
Closing time	ms	650
Opening time	ms	600
Electrical position indicator, load capacity	VAC / A VDC / A	250 / 0.125 50 / 0.25
Compressed air, overpressure	bar	4 – 8
Air cylinder volume	cm ³	570
Mounting orientation		any
Seals		FPM
Weight	kg	11.4

DN 160 - continued

Dimensions

VAP160-A

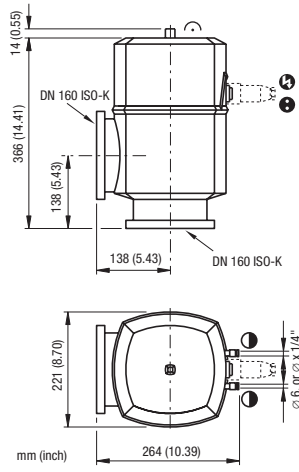

Butterfly Valves Manually actuated

VBH063 ... 160-X

Advantages

- Three sizes available: DN 63, 100, 160
- Robust and compact design with low installation height
- High conductance all stainless steel housings
- Lateral gauge/valve flange connections standard
- FPM sealings
- Extremely long service lifetime

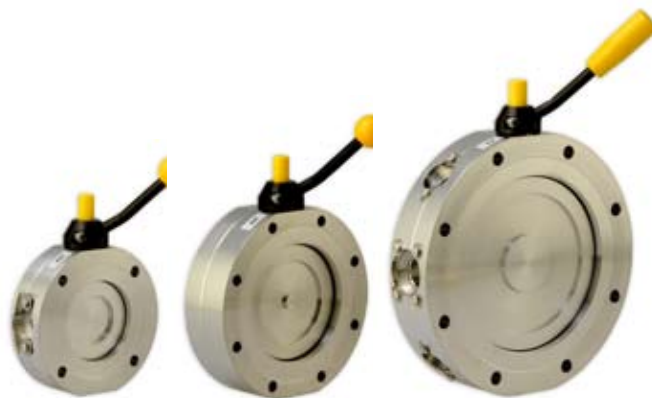

Selection Data

Vacuum connection	DN 63 ISO-F	DN 100 ISO-F	DN 160 ISO-F
-------------------	-------------	--------------	--------------

Ordering Information

Type	VBH063-X	VBH100-X	VBH160-X
	250-560	250-570	250-580

Specifications

Lateral vacuum connections		DN 10 ISO-KF DN 16 ISO-KF	2 x DN 10 ISO-KF DN 25 ISO-KF	2 x DN 10 ISO-KF DN 25 ISO-KF
Cycle life	Cycles	100,000	100,000	100,000
Conductance for molecular flow	l/s	350	1000	3400
Tightness	mbar l/s	1×10^{-9}	1×10^{-9}	1×10^{-9}
Pressure in either direction				
Static min. / max.	mbar / bar	1×10^{-8} / 10	1×10^{-8} / 10	1×10^{-8} / 10
Dynamic min. / max	mbar / bar	1×10^{-8} / 4	1×10^{-8} / 4	1×10^{-8} / 4
Pressure difference Δp				
In either direction	bar	4	4	4
Bakeout teperature housing	°C	150	150	150
Housing, shaft, valve plate	AISI / DIN	304 / 1.4301	304 / 1.4301	304 / 1.4301
Seals		FPM	FPM	FPM
Weight	kg	3.1	5.2	9.3

VBH063 ... 160-X - continued

Accessories

	VBH063	VBH100	VBH160
Connection elements X type	215-212	215-214	215-216

Spare Parts

	VBH063	VBH100	VBH160
Seal kit X type	215-143	215-145	215-147

Dimensions

VBH063-X

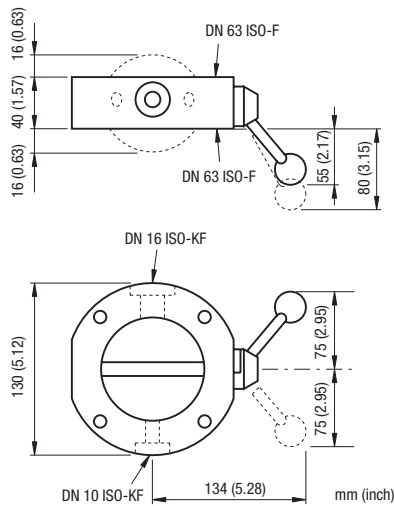

VBH100-X

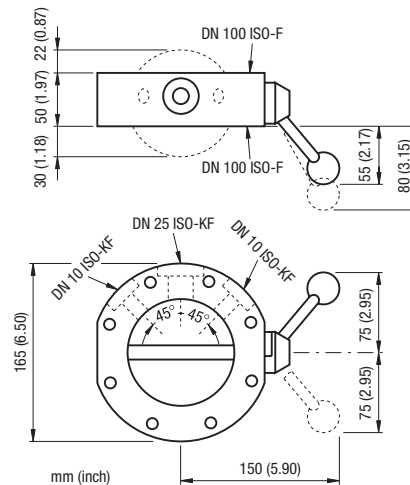

VBH160-X

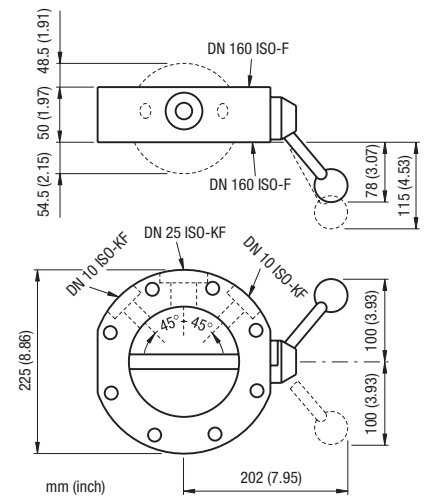

Pneumatically Actuated Butterfly Valves (VBP)

VBP063 ... 250-X/Z



Advantages

- Four sizes available: DN 63, 100, 160, 250
- Robust and compact design with low installation height
- High conductance all stainless steel housings
- With or without lateral gauge/valve flange connections
- FPM sealings
- Extremely long service lifetime
- Direct pneumatic actuation or via pilot valve
- Electrical and visual position indicator

VBP063 ... 250-X/Z - continued

Selection Data

Vacuum connection	DN 63 ISO-F	DN 100 ISO-F	DN 160 ISO-F	DN 250 ISO-K
Lateral vacuum connections	DN 10 ISO-KF DN 16 ISO-KF	2 x DN 10 ISO-KF DN 25 ISO-KF	2 x DN 10 ISO-KF DN 25 ISO-KF	2 x DN 10 ISO-KF DN 25 ISO-KF DN 40 ISO-KF

Ordering Information
With lateral vacuum connections

Type	VBP063-X	VBP100-X	VBP160-X	VBP250-X
	253-100	253-120	253-140	253-160

Without lateral vacuum connections

Type	VBP063-Z	VBP100-Z	VBP160-Z	VBP250-Z
	253-110	253-130	253-150	253-170

Specifications

Cycle life	Cycles	1,000,000	1,500,000	1,500,000	1,000,000
Conductance for molecular flow					
X types	l/s	350	1000	3400	8200
Z types	l/s	400	1400	4000	8200
Tightness	mbar l/s	1×10^{-9}	1×10^{-9}	1×10^{-9}	1×10^{-9}
Pressure in either direction					
Static min. / max.	mbar / bar	1×10^{-8} / 10	1×10^{-8} / 10	1×10^{-8} / 10	1×10^{-8} / 10
Dynamic min. / max	mbar / bar	1×10^{-8} / 4	1×10^{-8} / 4	1×10^{-8} / 4	1×10^{-8} / 4
Pressure difference Δp					
In either direction	bar	4	4	4	4
Bakeout temperature housing	°C	150	150	150	150
Housing, shaft, valve plate	AISI / DIN	304 / 1.4301	304 / 1.4301	304 / 1.4301	304 / 1.4301
Seals		FPM	FPM	FPM	FPM
Weight					
X types	kg	3.8	6.5	10	15.7
Z types	kg	3.5	5	8	16

VBP063 ... 250-X/Z - continued

Spare Parts

	VBP063	VBP100	VBP160	VBP250
Seal kit				
X type	215-143	215-145	215-147	215-149
Z type	215-144	215-146	215-148	215-149
Actuator	253-181	253-182	253-182	253-183

Accessories

	VBP063	VBP100	VBP160	VBP250
Position indicator	253-180	253-180	253-180	253-180
Pilot valve				
230 V AC / 50 Hz	215-131	215-131	215-131	215-131
115 V AC / 60 Hz	215-132	215-132	215-132	215-132
24 V AC / 50 Hz	215-133	215-133	215-133	215-133
24 V DC / 50 Hz	215-134	215-134	215-134	215-134
Connection elements				
X type	215-212	215-214	215-216	212-225
Z type	215-213	215-215	215-217	212-225

Dimensions

VBP063-X

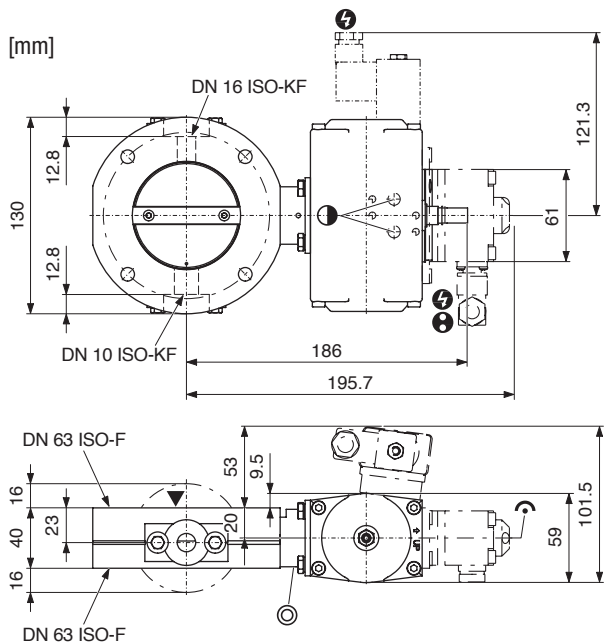

VBP063-Z

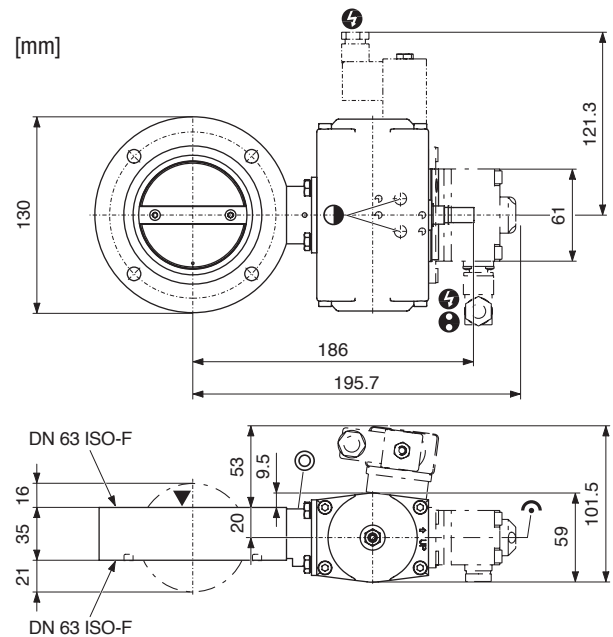

- ⊕ Compressed air connection
- ⚡ Electrical connection
- ⊕ Position indicator connection
- ▼ Valve seat site
- 👁 Visual position indicator
- ⊙ Leak detection opening

VBP063 ... 250-X/Z - continued





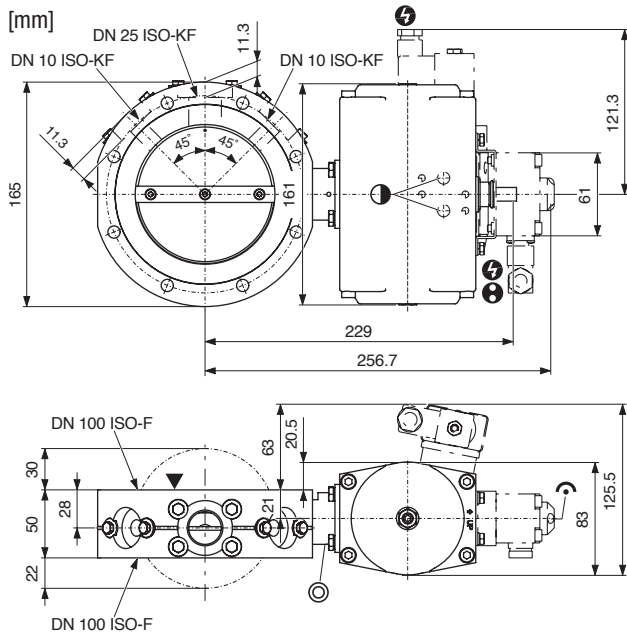

Dimensions

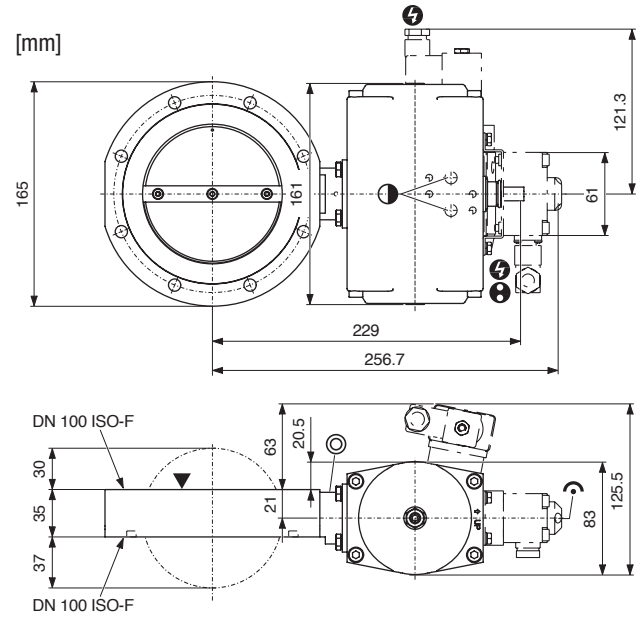
VBP100-X



VBP100-Z



-  Compressed air connection
-  Position indicator connection
-  Visual position indicator
-  Electrical connection
-  Valve seat site
-  Leak detection opening

VBP063 ... 250-X/Z - continued





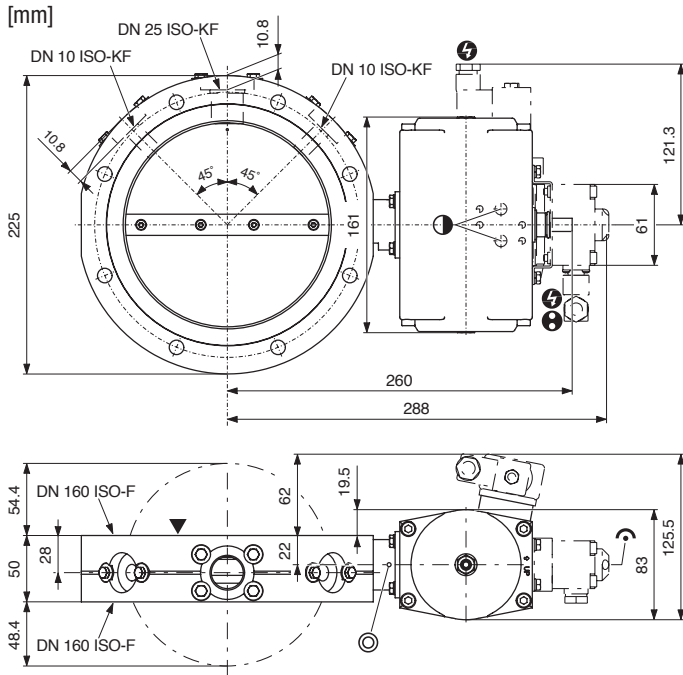

Dimensions

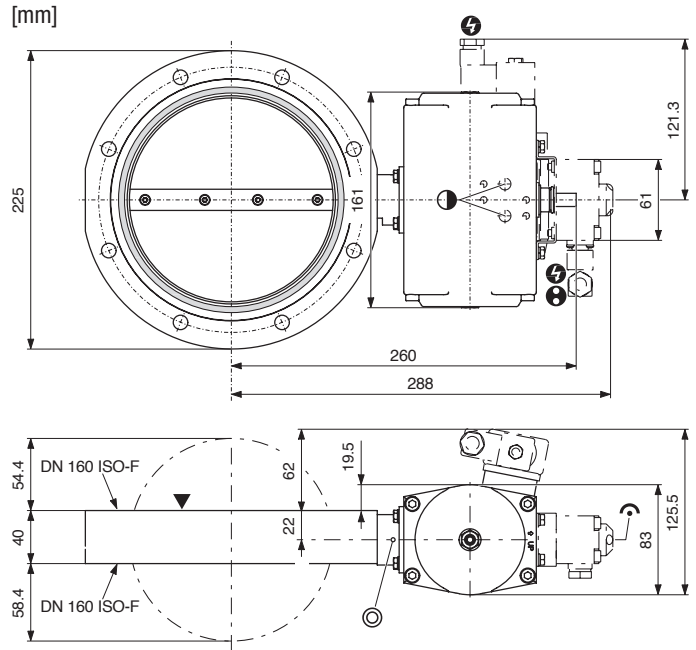
VBP160-X



VBP160-Z



-  Compressed air connection
-  Position indicator connection
-  Visual position indicator
-  Electrical connection
-  Valve seat site
-  Leak detection opening

VBP063 ... 250-X/Z - continued





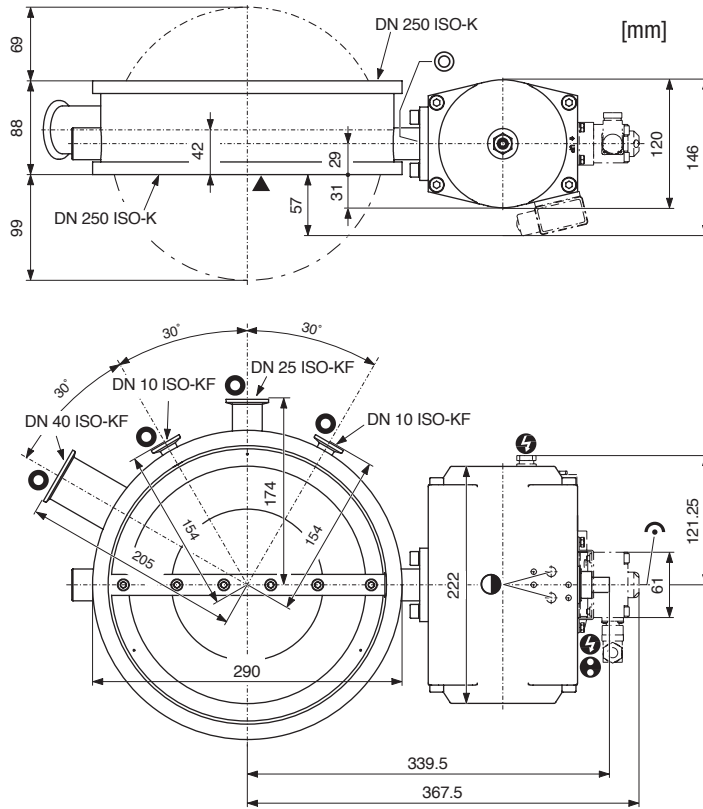

Dimensions

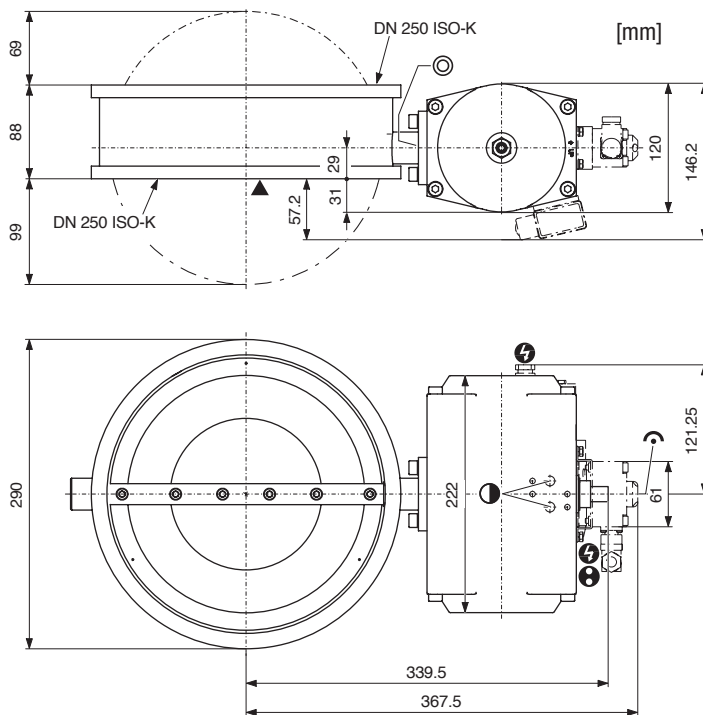
VBP250-X



VBP250-Z



-  Compressed air connection
-  Electrical connection
-  Position indicator connection
-  Valve seat site
-  Visual position indicator
-  Leak detection opening

Manually Actuated Coarse Gas Dosing Valve

VDH010-A

Advantages

- For admitting a reproducible flow of gas into a vacuum chamber



Selection Data

Vacuum connection	DN 10 ISO-KF	
Gas flow, controllable		
Min.	mbar l/s	40
Max.	mbar l/s	1700

Ordering Information

Type	VDH010-A
Part No.	250-520

Specifications

Tightness	mbar l/s	1×10^{-8}
Pressure range	mbar to bar	1×10^{-7} to 4
Bakeout temperature	°C	100
Housing	aluminum	
Seals	FPM	
Weight	kg	0.2

Spare Parts

Seal set	215-207
----------	----------------

Dimensions

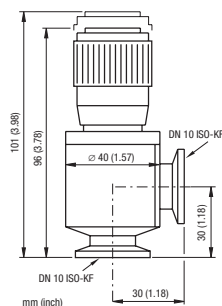

Manually Actuated Dosing and Shut-Off Valve

VDH016-X

Advantages

- Very wide control range
- Optimal control characteristics
- Digital display
- Excellent reproducibility
- Extremely small dead volume
- Integrated shut-off valve
- Closing without change of flow setting



Selection Data

Vacuum connection		DN 16 ISO-KF
Gas flow, controllable		
Min.	mbar/l/s	5×10^{-6}
Max.	mbar/l/s	1000

Ordering Information

Type	VDH016-X
Part No.	250-500

Specifications

Tightness	mbar/l/s	1×10^{-9}
Differential pressure	bar	2.5
Dead volume	cm ³	0.032
Operating temperature	°C	80
Bakeout temperature, flanges	°C	150
Housing, needle, filter		stainless steel
Dosing sleeve		Fluorplastomer
Seal		FPM
Weight	kg	0.4

Accessories

Filter, vacuum side		
590 mbar l/s	Part No.	215-462
1250 mbar l/s	Part No.	215-463

VDH016-X - continued

Dimensions

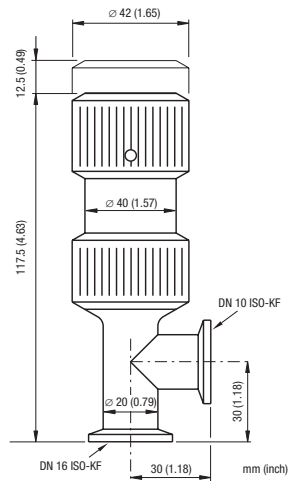

All-Metal Dosing Valves and System

VDH040-U / VDE040-U / VCE500

Advantages

- Minimal dead volume
- Controlled routing of the gas flow using capillaries
- Operating temperature 200°C
- Control of total pressure or gas flow
- Automatic control in conjunction with VDE40-U and VCE500



Selection Data

Actuator	manual	manual and thermo-mechanical in conjunction with VCE500
----------	--------	--

Ordering Information VDH040-U / VDE040-U

Type	VDH040-U	VDE040-U
Valve	250-700	250-720

Specifications

Connection flange			
Input		DN 16 CF-R	DN 16 CF-R
Output		DN 40 CF-F	DN 40 CF-F
Gas flow, controllable			
Min.	mbar/l/s	1×10^{-10}	1×10^{-10}
Max.	mbar/l/s	600	100 ¹⁾
Tightness	mbar/l/s	1×10^{-11}	1×10^{-11}
Pressure min./max. (absolute)	mbar	$1 \times 10^{-11}/30$	$1 \times 10^{-10}/30$
Conductance for molecular flow	l/s	0.7	0.7
Operating temperature	°C	200	200
Bakeout temperature	°C	350	350 ²⁾
Valve plate		sapphire	sapphire
Valve seat		copper	copper
Housing		stainless steel	stainless steel
Weight	kg	1.4	1.4

¹⁾ Can be regulated with the VCE500 Controller

²⁾ Without cable

VDH040-U / VDE040-U / VCE500 - continued

Accessories

Type	VDH040-U	VDE040-U
Capillary complete, vacuum side, 1m	215-708	215-708
Heater, 200°C	250-701	250-701
Adapter DN 40/16 CF	213-071	213-071

Options

Tool kit	215-707	215-707
----------	---------	---------

Spare Parts

Valve plate, sapphire	215-715	215-715
Valve seat		
Standard	215-716	215-716
Gold plated	215-717	215-717

Ordering Information VCE500

Controller for VDE040-U	VCE500
Part No.	250-920

Specifications

Power supply	V	115 / 230
Frequency	Hz	50 ... 60
Power consumption	VA	20
Regulating characteristic		proportional-integral (PI)
Reset time	s	2 ... 30
Proportional gain		2 ... 1000
Internal nominal value		
Scale divisions		0 ... 1000
External nominal value	VCD/100 k	0 ... +10
Protection class		IP 20

Cable

Standard, 80°C		
3 m	Part No.	202-914
12 m (max. cable length)	Part No.	202-916
Extension, 200°C		
2 m	Part No.	202-924

VDH040-U / VDE040-U / VCE500 - continued

Dimensions

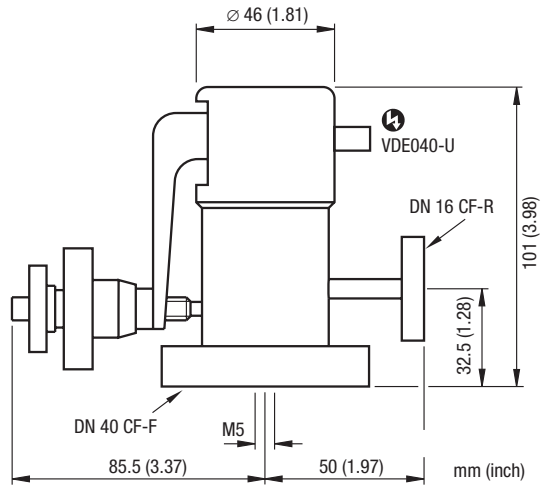

Gas Dosing Systems

User Advantages

- Higher yield
- Optimized cycle time
- Excellent reproducibility
- Easy system integration

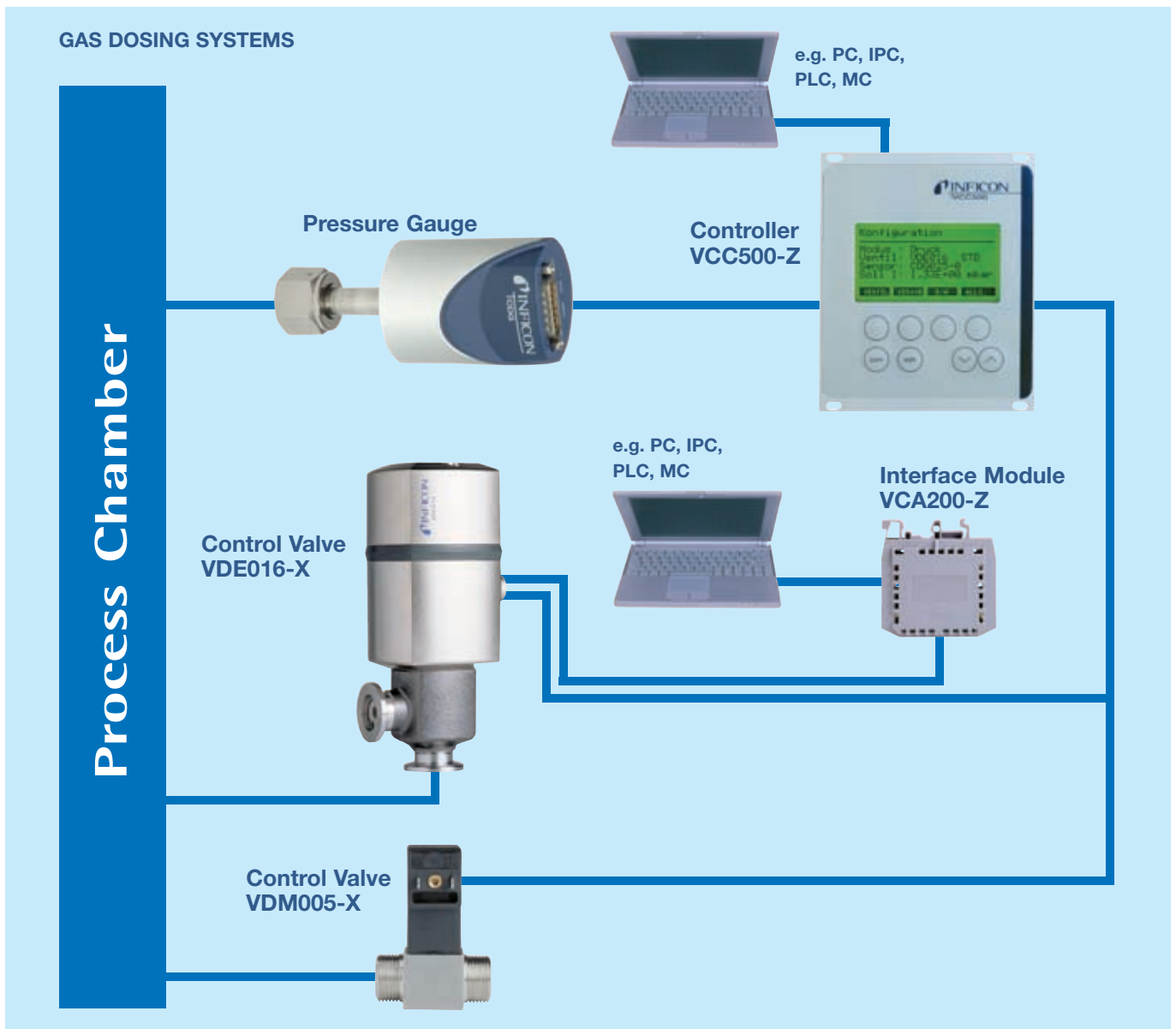

Solenoid Control Valves

Control Valve VDM005A-X

User Advantages

- Fast response time
- Excellent control characteristics
- High reproducibility and repeatability
- Stainless steel housing
- Closes automatically in case of power failure
- Smooth solenoid drive
- Optional flange connection
- Very compact design

Selection Data

Vacuum connection	DN 5 mm / M 14 x 1
Control range	1 ... 100 %FS 20 ... 70 mA
Pressure range (outlet)	1 x 10 ⁻⁹ mbar
Pressure max. in closing direction	2 bar
Response time	<30 ms

Ordering Information

Type	VDM005A-X
10 sccm	250-508
50 sccm	250-509
100 sccm	250-510
500 sccm	250-511
1000 sccm	250-512
5000 sccm	250-513

Cable VCC - VDM

3m	216-160
5m	216-161
10m	216-162
15m	216-163
20m	216-164
25m	216-165

Accessories

DN 10 ISO-KF flange connection	250-080
Pipe OD 1/4" connection	250-085
Pipe OD 6 mm connection	250-086
Other connections	on request
Filter set (10 pcs.)	215-519



Technical Data

Tightness	1 x 10 ⁻⁹ mbar l/s
Actuator	solenoid
Controller	VCC500-Z
Ambient temperature	+5 ... +50 °C
Duty cycle	100 %
Protection type	IP51
Supply voltage	0 ... 24 V DC
Power consumption	2.5 W max.
Housing	stainless steel
Seals	FPM
Weight (without connection)	96 g

Technical Drawing

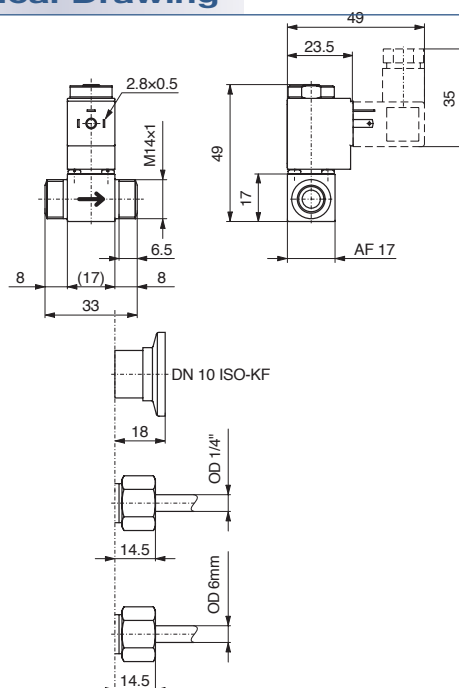

Control Valve VDE016-X

User Advantages

- Broad control range
- Excellent reproducibility
- Status information and commands via digital interface
- Withstands corrosive gases - stainless steel / FPM
- Combined with the VCC500-Z controller, the valve closes automatically in case of a power failure



Selection Data

Vacuum connection	DN 16 ISO-KF
Gas flow, controllable	
Min.	5×10^{-6} mbar l/s
Max.	1250 mbar l/s
Pressure absolute	
Min.	1×10^{-3} mbar
Max.	2.5 bar
Closing / opening time	3 / 4 s

Ordering Information¹⁾

Type	VDE016-X
Part No.	250-505

1) Connector included

Cable VCC - VDE

3 m	Part No.	216-150
5 m	Part No.	216-151
10 m	Part No.	216-152
15 m	Part No.	216-153
20 m	Part No.	216-154
25 m	Part No.	216-155

Technical Data

Tightness	1×10^{-9} mbar l/s
Actuator	Stepper motor
Control	
Digital	VCC500-Z, VCA200-Z
Analog	0 ... 10 V DC
Ambient temperature	5 ... 40 °C
Supply	24 V DC / 12 VA
Housing	stainless steel
Dosing sleeve	fluorplastomer
Seals	FPM
Weight ¹⁾	0.5 kg

1) Connector included

Technical Drawing

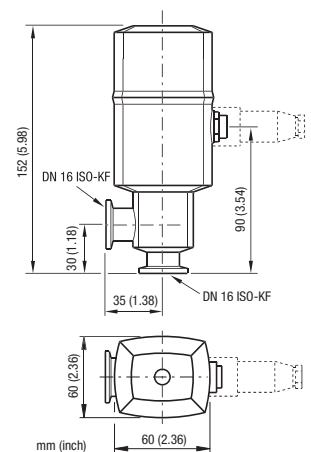

Controller VCC500-Z

User Advantages

- Simple operation - user friendly LCD display and function keys
- Analog/digital inputs, outputs and interfaces
- 99 PI pre-programmed control adjustments for quick and easy operation
- Adjustable PID control algorithm
- Wide variety of pre-programmed pressure gauges



Selection Data

Analog input	0 ... 10 V DC nominal pressure, gas flow
Analog output	0 ... 10 V DC pressure, valve position

Ordering Information¹⁾

Type	VCC500-Z
Part No.	250-900

Technical Data

Operating modes	Pressure control Gas flow adjustment
8 available digital inputs	Flow adjustment, opening/closing the valve, switching between pressure and gas flow control
8 available digital outputs	Valve position indication, setpoint status reached, status messages - sensor, valve, pressure control upstream and downstream
Features	Switching on after power failure Output "nominal value reached", adjustable tolerance
Units	mbar, Pa, Torr, mV
Languages	English, German
Interfaces	RS232C, RS485
Controller types	Auto = PI - selectable control speed steps 1-99 PID = PID - user definable parameters
Control accuracy	5 % FS sensors
Display accuracy	0.2 % FS sensor
Supply	
Voltage	90 ... 250 V AC
Consumption	50 VA
Weight	1.65 kg

Technical Drawing

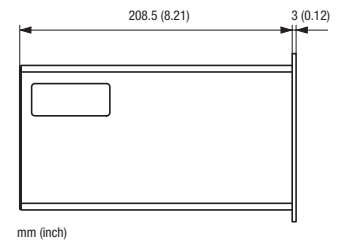
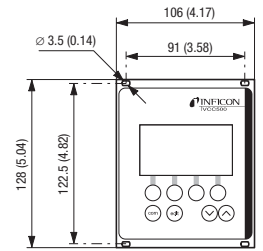

Interface Module VCA200-Z

User Advantages

- Easy and economic system integration
- Connects an RS232C interface to the digital interface of the Control Valve VDE016-X
- Inquiry of status and valve position



Selection Data

Interface	RS232C
Supply	24 VDC / 0.5 A

Ordering Information

Type	VCA200-Z
Part No.	250-915

Technical Data

Installation	DIN mounting rail (symmetric or asymmetric)
Connection	terminals
Ambient temperature	5 ... 50°C
Weight	40 g

Technical Drawing

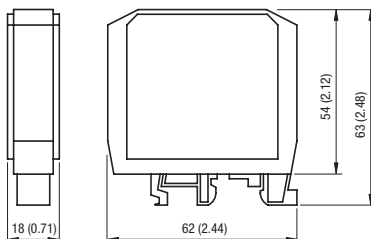

Solenoid Control Valve

Control Valve VDM005A-X

The INFICON Solenoid Control Valve VDM005A-X offers a fast and reproducible upstream pressure control. A newly designed solenoid control mechanism allows smooth control and provides excellent repeatability and reproducibility. The VDM005A-X is the successor to the VDM005-X and can be used as a drop in replacement, as the electrical and vacuum connections are exactly the same.



User Advantages

- Fast response time
- Excellent control characteristics
- High reproducibility and repeatability
- Stainless steel housing
- Closes automatically in case of power failure
- Smooth solenoid drive
- Optional flange connection
- Very compact design

Applications

- Upstream pressure control for coating processes
- General gas inlet for rough and high vacuum systems

Ordering Information

Type	VDM005A-X
10 sccm	250-508
50 sccm	250-509
100 sccm	250-510
500 sccm	250-511
1000 sccm	250-512
5000 sccm	250-513

Accessories

DN 10 ISO-KF flange connection	250-080
Pipe OD 1/4" connection	250-085
Pipe OD 6 mm connection	250-086
Other connections	on request
Filter set (10 pcs.)	215-519

CONTROL VALVE VDM005A-X - continued

Specifications

			VDM005A-X
Actuator			solenoid
Control range	% FS		1 ... 100
	mA		20 ... 70
Tightness	mbar l/s		1.0×10^{-9}
Pressure range (outlet)	mbar		1.0×10^{-8} ... 1000
Pressure, max.	in closing direction	bar	2
Temperature			
Operation (ambient)	°C		+5 ... +50
Bakeout (without supply voltage)	°C		+80
Supply voltage	V DC		0 ... 24
Power consumption	W		2.5
Response time	ms		< 30
Weight (without connection)	g		96
Materials exposed to vacuum			FPM, stainless steel
Protection type			IP51

Dimensions

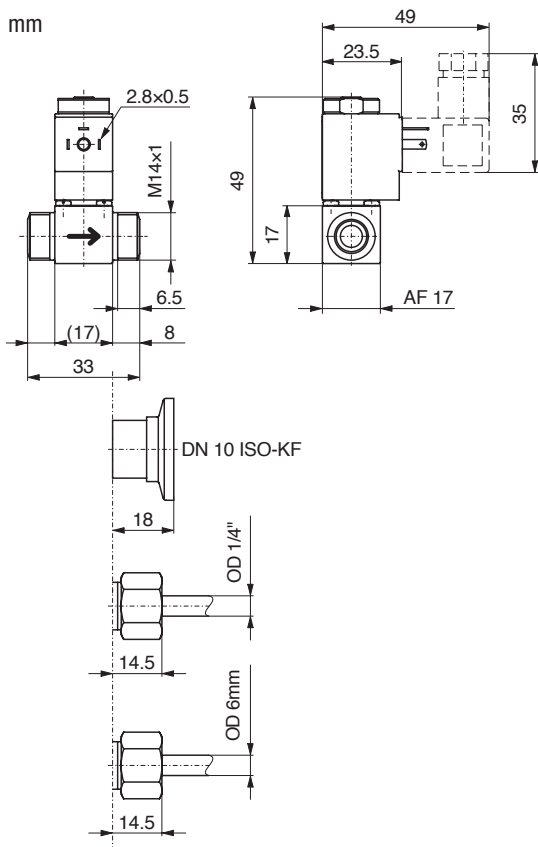

Manually Actuated Angle Valves with CF-Flanges (VAH)

DN 16–63

Standard

- For UHV and HV applications
- Bakeable at up to 180°C in open and closed position
- FPM sealed
- Maintenance-free

All-metal

- For UHV applications
- Bakeable at up to 300°C in open and closed position
- Copper sealed
- Maintenance-free



Selection Data

		STANDARD			ALL - METAL		
Vacuum connection		DN16 CF-R	DN40 CF-R	DN 63 CF-R	DN16 CF-R	DN40 CF-R	DN 63 CF-R
Tightness	mbar l/s	1 X 10 ⁻¹⁰	1 X 10 ⁻¹⁰	1 X 10 ⁻¹⁰	5 X 10 ⁻¹¹	5 X 10 ⁻¹¹	5 X 10 ⁻¹¹
Bakeout temperature w/o hand wheel	°C	180	180	180	300	300	300

Ordering Information

Type	VAH016-Z	VAH040-Z	VAH063-Z	VAH016-U	VAH040-U	VAH063-U
Part No.	250-731	250-736	250-741	250-730	250-735	250-740

Specifications

Service life	cycles	50 000	50 000	50 000	1000	1000	1000
Conductance for molecular flow	l/s	3	38	100	3	38	100
Pressure (absolute) min. / max.	mbar/bar	1 x 10 ⁻⁹ / 4	1 x 10 ⁻⁹ / 4	1 x 10 ⁻⁹ / 4	1 x 10 ⁻¹⁰ / 4	1 x 10 ⁻¹⁰ / 4	1 x 10 ⁻¹⁰ / 4
Tightening torque	Nm	≤ 1	≤ 1.8	≤ 2.5	8-10	20-40	30-60
Heating and cooling rate	°C/min	—	—	—	4	4	2
Bellows, stainless steel AISI/DIN		321/1.4541	321/1.4541	321/1.4541	321/1.4541	321/1.4541	321/1.4541
Housing, stainless steel AISI/DIN		304/1.4301 welded	304/1.4301 welded	304/1.4301 welded	304/1.4301 welded	304/1.4301 welded	304/1.4301 welded
Valve plate, seal		FPM	FPM	FPM	copper	copper	copper
Valve plate, stainless steel AISI/DIN		304/1.4301	304/1.4301	304/1.4301	304/1.4301	304/1.4301	304/1.4301
Weight	kg	0.35	1.8	4.8	0.4	2.0	5.0

Spare Parts

FPM seal, 10 pieces	Part No.	215-341	215-342	215-343	—	—	—
Copper seal, 2 pieces	Part No.	—	—	—	215-344	215-345	215-346

DN 16-63 - continued

Dimensions

VAH016-Z

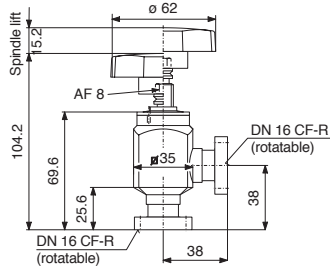

VAH040-Z

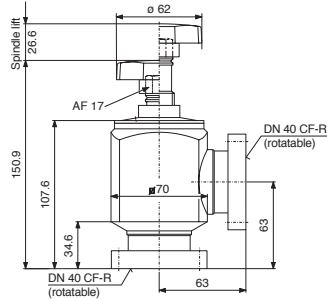

VAH063-Z

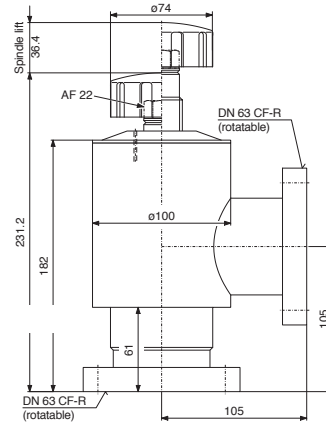

VAH016-U

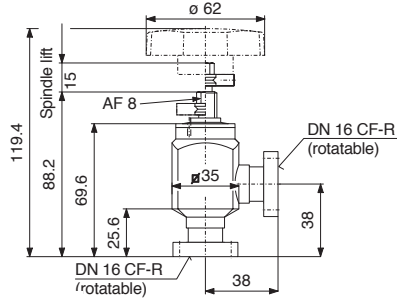

VAH040-U

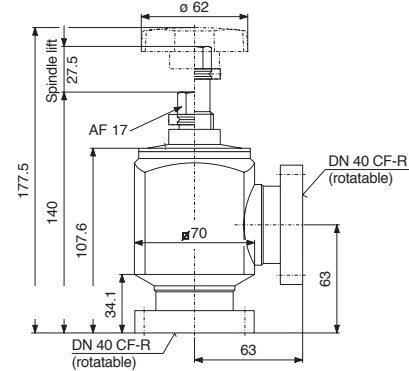

VAH063-U

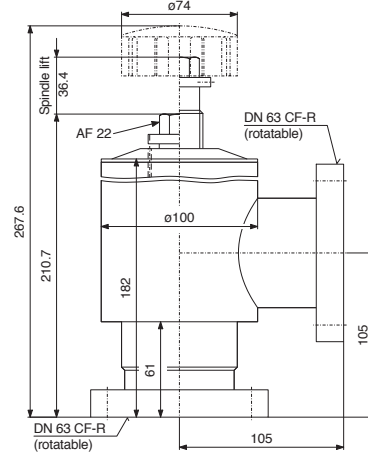

Manually Actuated Venting Valve

VVH010-A/X

Advantages

- Simple opening and closing of the valve by loosening or tightening the screw cap



Selection Data

Vacuum connection		DN 10 ISO-KF	DN 10 ISO-KF
Housing	AISI / DIN	aluminum / 3.0615	stainless steel 303 / 1.4305

Ordering Information

Type	VVH010-A	VVH010-X
Part No.	250-840	250-841

Specifications

Tightness	mbar l/s	1×10^{-9}	1×10^{-9}
Pressure (absolute)	mbar/bar	$1 \times 10^{-8} / 1$	$1 \times 10^{-8} / 1$
Valve plate		aluminum	stainless steel 304 / 1.4301
Screw cap		brass nickel-plated	brass nickel-plated
Seal		FPM	FPM
Weight	kg	0.1	0.15

Spare Parts

O-ring	B 4070 207 PV	B 4070 207 PV
--------	----------------------	----------------------

Dimensions

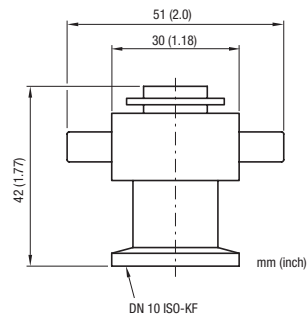

Solenoid Actuated Venting Valve

VVM010-A

Advantages

- No vacuum feedthrough
- Long service life
- Mountable in any position



Selection Data

Vacuum connection	DN 10 ISO-KF
-------------------	--------------

Ordering Information

Type	Part No.	VVM010-A
230 V AC, 50/60 Hz	Part No.	250-533
115 V AC, 50/60 Hz	Part No.	250-532
24 V AC, 50/60 Hz	Part No.	250-531
24 V DC	Part No.	250-530

Specifications

Service life	cycles	1 500 000
Tightness	mbar l/s	1×10^{-9}
Conductance for molecular flow	l/s	1
Conductance at 1mbar	l/s	3.5
Pressure absolute min./max.	mbar/bar	1×10^{-8}
Duty cycle	%	100
Differential pressure in closing / opening direction	bar	10 / 1
opens to a pressure difference of	bar	2
Ambient temperature	°C	5 – 40
Pickup / holding power	VA	35 / 15
Pressure resistance	bar	10
Closing / opening time	ms	60 / 45
Switching frequency	1/min	50
Housing		aluminum
Seals		FPM
Weight	kg	0.46

VVM010-A - continued

Options

Filter with port, centering ring and clamping ring

215-152

Spare Parts

Seal set
Filter

215-208
B 4161 210 4F

Dimensions

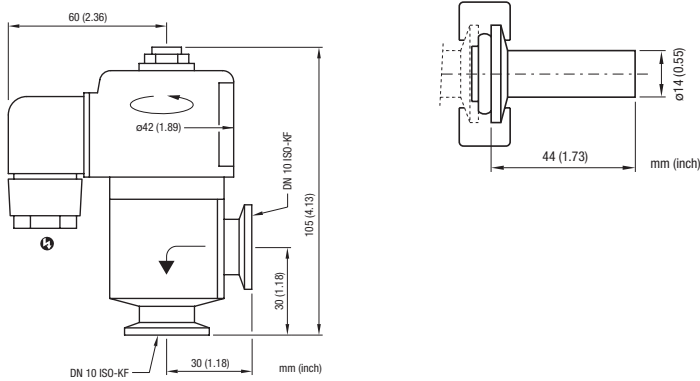

Power Failure Venting Valve

VIM010-A

Advantages

- For automatic venting of pumps, system or vacuum chambers in case of a power failure



Selection Data

Vacuum connection	DN 10 ISO-KF
Venting time for a 50 l vessel	270 s

Ordering Information

Type	VIM010-A
200 - 230 V, 50/60 Hz	250-851
24 V DC	250-850
115 V, 50/60 Hz	250-852

Specifications

Part number	250-850	250-851	250-852
Tightness	mbar l/s	1 x 10 ⁻⁷	
Ambient temperature	°C	0 – 50	
Switching frequency	1/min	60	
Service life	Mio cycles	3	
Opening time	ms	30	
Closing time	ms	30	
Housing		aluminum	
Seal		FPM	
Nominal power			
Pickup	W / VA	2.5 / –	– / 5
Holding	W / VA	2.5 / –	– / 3.7
Protection class		IP 65	
Weight	kg	0.1	

Dimensions

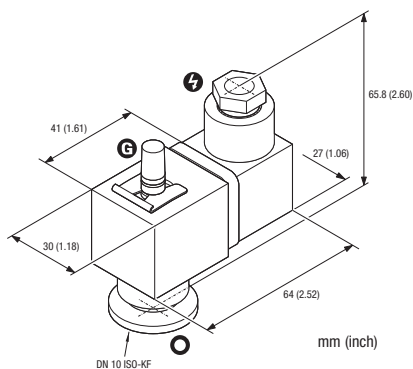

Vacuum Safety Valves

VSM DN 16 – DN 100

Advantages

- Fast-closing high vacuum isolation valve for separating the vacuum chamber from the backing pump
- Venting valve for roughing pumps
- Immediate closing action upon power failure
- Opening action only after the intake line has been evacuated



Selection Data

Vacuum connection	DN 16 ISO-KF	DN 25 ISO-KF	DN 40 ISO-KF	DN 63 ISO-K	DN 100 ISO-K
-------------------	--------------	--------------	--------------	-------------	--------------

Ordering Information

Type	VSM016-A	VSM025-A	VSM040-A	VSM063-A	VSM100-A
200 - 230 V AC	253-004	253-014	253-024	253-034	253-044
100 - 115 V AC	253-002	253-012	253-022	253-032	253-042
24 V DC	253-000	253-010	253-020	253-030	253-040

Specifications

Nominal power	DC AC	2.5 W 5 / 3.7 VA (starting / holding)			
Type of protection	IP 65 according to DIN 40 050				
Conductance	3.8 l/s	11 l/s	30.5 l/s	126 l/s	300 l/s
Installation position	any				
Tightness	body valve plate	< 1x10 ⁻⁹ mbar l/s < 1x10 ⁻⁵ mbar l/s			
Pressure range	1x10 ⁻⁸ mbar – 1 bar (abs.)				
Required pressure difference up for the safety valves to function properly	in closing direction		> 150 mbar		
	in opening direction		< 150 mbar		
Temperatures	ambiance 5°C – 50°C				
Solenoid coil	ambiance 20°C		< 55°C		
	ambiance 20°C		< 80°C		
Bakeout	housing		< 60°C		
	actuator		< 50°C		
Materials	housing, flange seals		aluminum FPM		
Weight	0.3 kg	0.5 kg	0.9 kg	2.4 kg	5.1 kg

VSM DN 16 – DN 100 – continued

Spare Parts

Seal set	215-055	215-056	215-057	215-058	215-059
----------	---------	---------	---------	---------	---------

Dimensions

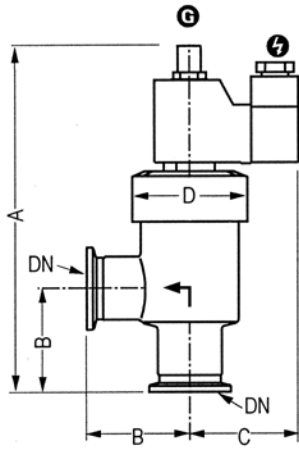

DN	A	B	C	D
DN 16 ISO-KF	139	40	49	44
DN 25 ISO-KF	162	50	49	56
DN 40 ISO-KF	178	65	49	82

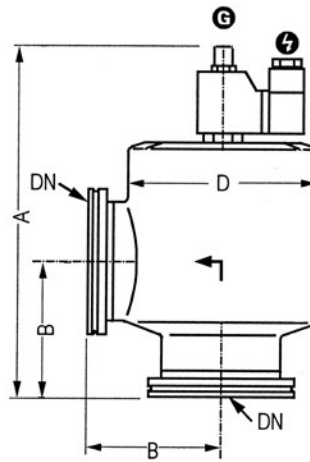

DN	A	B	D
DN 63 ISO-K	220	88	124
DN 100 ISO-K	264	108	164

Pressure Relief Valve

VSA016-X

Advantages

- Protects vacuum systems from pressure >1.5bar
- Relief trigger point 1.2 to 1.5 bar absolute



Selection Data

Vacuum connection	DN 16 ISO-KF
-------------------	--------------

Ordering Information

Type	VSA016-X
Part No.	250-555

Specifications

Tightness	mbar l/s	1×10^{-9}
Pressure absolute min./max.	mbar / bar	1×10^{-3} / 1.2 (absolute)
Gas flow	l/min	0 – 6
Ambient temperature	°C	0 – 50
Bakeout temperature	°C	150
Housing		stainless steel
Seal		FPM
Weight	kg	0.1

Dimensions

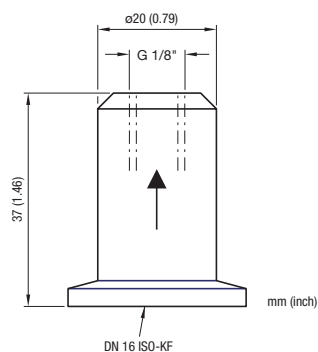

Ball Valves with ISO-KF Flanges

DN 10-40

Advantages

- Rugged and cost effective
- Simple opening and closing by lever
- Unobstructed passage



Selection Data

Vacuum connection	DN 10 ISO-KF	DN 16 ISO-KF	DN 25 ISO-KF	DN 40 ISO-KF
-------------------	--------------	--------------	--------------	--------------

Ordering Information

Part No.	215-860	215-861	215-862	215-863
----------	---------	---------	---------	---------

Specifications

Tightness	mbar/ls	1×10^{-5}	1×10^{-5}	1×10^{-5}	1×10^{-5}
Conductance for molecular flow	l/s	1.5	3	9	30
Pressure absolute min./max.	mbar/bar	$10^{-5} / 5^{1)}$	$10^{-5} / 5^{1)}$	$10^{-5} / 5^{1)}$	$10^{-5} / 5^{1)}$
Bakeout temperature	°C	80	80	80	80
Housing		brass nickel plated	brass nickel plated	brass nickel plated	brass nickel plated
Seals		PTFE	PTFE	PTFE	PTFE
Weight	kg	0.35	0.35	0.35	0.35

1) With outer centering ring

Dimensions

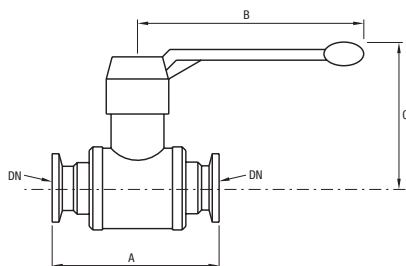

DN	A	B	C
DN 10 ISO-KF	75	83	47
DN 16 ISO-KF	100	95	51
DN 25 ISO-KF	130	110	64
DN 40 ISO-KF	160	160	85

Vacuum Fittings

Fittings and Ultra-High Components

VACUUM FITTINGS

ISO-KF Small Flange Components

CONNECTION ELEMENTS	D1
SEALS.....	D3
FLANGES	D6
PIPE FITTINGS.....	D7
BELLOWS/HOSE WITH FLANGES	D9
TRANSITION PIECES.....	D11
HOSE, HOSE CONNECTION.....	D14

ISO-K Clamp Flange Components

CONNECTION ELEMENTS	D16
SEALS.....	D17
FLANGES	D20
PIPE FITTINGS.....	D22
BELLOWS / HOSE WITH FLANGES	D24
TRANSITION PIECES.....	D25
PROTECTIVE LIDS	D26

ISO-F Fixed Flange Components

FLANGE COMPONENTS	D27
-------------------------	-----

UHV CF Components

CONNECTION ELEMENTS	D29
SEALS.....	D30
FLANGES	D32
PIPE FITTINGS.....	D36
BELLOWS / HOSE WITH FLANGES, COMPENSATOR.....	D38
TRANSITION PIECES.....	D39
PROTECTIVE LIDS	D40

Website

ISO-KF Small Flange Components

CONNECTION ELEMENTS

Clamping Ring		DN ... ISO-KF	Part No.	A	B	C
Clamping ring half:	Aluminum 380.0/3.2162	10 – 16	211-001	45	61	16
Bolt & nut:	Steel nickel plated	20 – 25	211-002	55	72	16
		32 – 40	211-003	70	90	18
		50	211-004	95	123	25

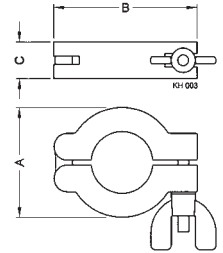

Rapid Fastening Clamp		DN ... ISO-KF	Part No.	A	B	C
Spring:	Steel	10 – 16	211-005	52	70	16
Clamping ring half:	Aluminum 380.0/3.2162	20 – 25	211-006	61	81	16
Lever:	Polyamide	32 – 40	211-007	75	98	18

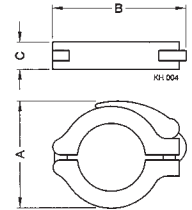

Hose Clip Clamping Ring		DN ... ISO-KF	Part No.	A	B	C
Clamping ring half:	Aluminum 380.0/3.2162	10 – 16	211-016	42	54	16
Band:	Stainless steel 430/1.4016	20 – 25	211-017	52	64	16
Bolt & nut thread:	Steel zinc plated	32 – 40	211-018	67	79	16

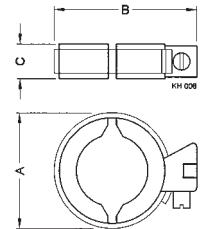

Clamping Element		DN ... ISO-KF	Part No.	A	B	C
Clamping Element:	Aluminum 380.0/3.2162	10 – 16	211-008	52		18
Bolt:	Stainless steel	20 – 25	211-009	55	72	16
Nut:	Steel zinc plated	32 – 40	211-010	70	90	18
		50	211-011	95	123	25

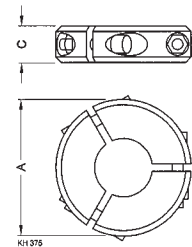

CONNECTION ELEMENTS - continued

Chain Clamp

		DN ... ISO-KF	Part No.	A	B	C
Chain link:	Aluminum 6081/3.2215	10 – 16	211-021	71	52.5	18
Screw & nut & bolts:	Stainless steel	20 – 25	211-022	82	65	18
		32 – 40	211-023	98	79	18
		50	211-024	117	97.5	20

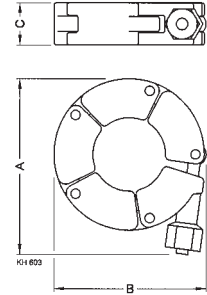

Claw Grip

		DN ... ISO-KF	Part No.	A	B	C	D	E	Set of
Claw:	Aluminum 6081/3.2215	10 – 50	211-015	19.5	11.5	12.5	20	14	4 pcs.
Screw & washer:	Stainless steel								

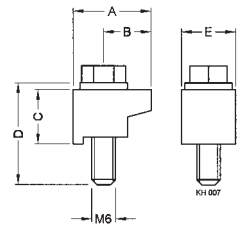

ISO-KF Small Flange Components

SEALS

Centering Ring		DN ... ISO-KF	Part No.	A	B	C	D
Ring: Aluminum 6082/- Seal: Elastomer CR	10	211-051	12	10	8	3.9	
	16	211-052	17	16	8	3.9	
	20	211-053	22	20	8	3.9	
	25	211-054	26	25	8	3.9	
	32	211-055	34	32	8	3.9	
	40	211-056	41	40	8	3.9	
	50	211-057	52	50	8	3.9	
Ring: Aluminum 6082/- Seal: Elastomer FPM	10	211-058	12	10	8	3.9	
	16	211-059	17	16	8	3.9	
	20	211-060	22	20	8	3.9	
	25	211-061	26	25	8	3.9	
	32	211-062	34	32	8	3.9	
	40	211-063	41	40	8	3.9	
	50	211-064	52	50	8	3.9	
Ring: Stainless steel 303/1.4305- Seal: Elastomer FPM	10	211-065	12	10	8	3.9	
	16	211-066	17	16	8	3.9	
	20	211-067	22	20	8	3.9	
	25	211-068	26	25	8	3.9	
	32	211-069	34	32	8	3.9	
	40	211-070	41	40	8	3.9	
	50	211-071	52	50	8	3.9	

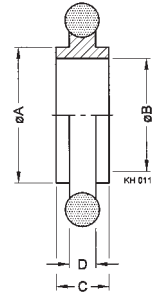

External Centering Ring		DN ... ISO-KF	Part No.	A	B	C	D
Ring: Aluminum 6082/- Seal: Elastomer CR	10-16	211-081	32	30.2	7	3.9	
	20-25	211-082	42	40.2	7	3.9	
	32-40	211-083	57	55.2	7	3.9	
	50	211-084	77	75.2	7	3.9	
Ring: Aluminum 6082/- Seal: Elastomer FPM	10-16	211-085	32	30.2	7	3.9	
	20-25	211-086	42	40.2	7	3.9	
	32-40	211-087	57	55.2	7	3.9	
	50	211-088	77	75.2	7	3.9	

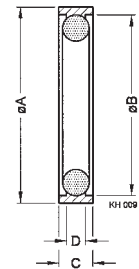

Reducing Centering Ring		DN ... ISO-KF	Part No.	A	B	C	D	E
Ring: Aluminum 6082/- Seal: Elastomer CR	10 / 16	211-072	17	10	12	8	3.9	
	20 / 25	211-073	26	20	22	8	3.9	
	32 / 40	211-074	41	32	34	8	3.9	
Ring: Aluminum 6082/- Seal: Elastomer FPM	10 / 16	211-075	17	10	12	8	3.9	
	20 / 25	211-076	26	20	22	8	3.9	
	32 / 40	211-077	41	32	34	8	3.9	
Ring: Stainless steel 303/1.4305 Seal: Elastomer FPM	10 / 16	211-078	17	10	12	8	3.9	
	20 / 25	211-079	26	20	22	8	3.9	
	32 / 40	211-080	41	32	34	8	3.9	

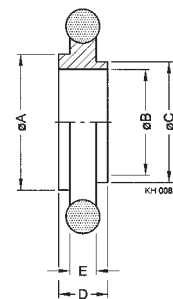

SEALS - continued

Centering Ring with Filter

	DN ... ISO-KF	Part No.	A	B	C	D	E*
Ring: Stainless steel 303/1.4305	10	211-089	12	8	8	3.9	0.5m ³ /h
Seal: Elastomer FPM	16	211-090	17	14	8	3.9	1.2m ³ /h
Filter: Stainless steel 316L/1.4435	25	211-092	26	23	8	3.9	4.2m ³ /h
Pore size 0.02 mm	40	211-094	41	38	8	3.9	11.3m ³ /h
* Air at 0°C, 20 mbar differential pressure	50	211-095	52	48	8	3.9	18.1m ³ /h

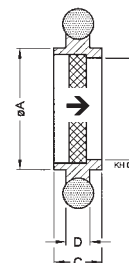

→ Recommended gas flow direction

Centering Ring with Fine Filter

	DN ... ISO-KF	Part No.	A	B	C	D
Inner ring: Stainless steel 303/1.4305	10	211-096	12	9	8	3.9
Snab ring: Stainless steel 304/1.4301	16	211-097	17	13	8	3.9
Seal: Elastomer FPM	25	211-098	26	22	8	3.9
Filter: Stainless steel 316L/1.4435	40	211-099	41	35.5	8	3.9
Pore size 0.004 mm	50	211-100	52	45.7	8	3.9
Degree of separation at 0.001 mm up to 98%						

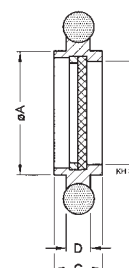

O-Ring

	DN ... ISO-KF	Part No.	A	B	Set of
Elastomer CR	10	211-146	15	5	10 pcs.
	16	211-147	18	5	10 pcs.
	20	211-148	25	5	10 pcs.
	25	211-149	28	5	10 pcs.
	32	211-150	40	5	10 pcs.
	40	211-151	42	5	10 pcs.
	50	211-152	55	5	10 pcs.
Elastomer FPM	10	211-153	15	5	10 pcs.
	16	211-154	18	5	10 pcs.
	20	211-155	25	5	10 pcs.
	25	211-156	28	5	10 pcs.
	32	211-157	40	5	10 pcs.
	40	211-158	42	5	10 pcs.
	50	211-159	55	5	10 pcs.



Indium Seal

	DN ... ISO-KF	Part No.	A	B	C	D	E
Inner ring: Stainless steel 304/1.4301	10-16	211-162	32	18	30	3.9	7
Outer ring: Aluminum 5012/-	20-25	211-163	42	28	40	3.9	7
Seal: Indium	32-40	211-164	57	43	55	3.9	7
Working temperature: -196° to +60°C	50	211-165	77	63	75	3.9	7

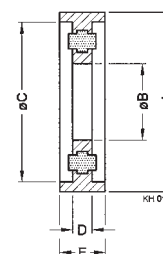

SEALS - continued

Aluminum Seal		DN ... ISO-KF	Part No.	A	B	C	D	With Support Ring
Aluminum anneated 6082/3.2315	10-16	211-167	25.6	19.6	4.5	22.6	211-171	
	20-25	211-168	35.6	29.6	4.5	32.6	211-168	
	32-40	211-169	50.6	44.6	4.5	47.6	211-173	
Set of 3 pieces	50	211-170	65.6	59.6	4.5	62.6	211-174	

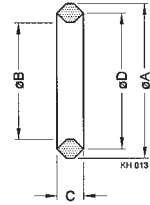

Support for Aluminum Seal		DN ... ISO-KF	Part No.	A	B	For Aluminum Seal
Stainless steel 301/1.4310	10-16	211-171	32	7	211-167	
	20-25	211-172	42	7	211-168	
	32-40	211-173	57	7	211-169	
Reusable	50	211-174	77	7	211-170	

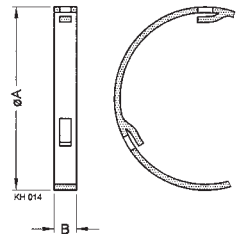

ISO-KF Small Flange Components

FLANGES

Blank Flange	DN ... ISO-KF	Part No.	A
Aluminum 6082/-	10	211-176	5
	16	211-177	5
	25	211-178	5
	40	211-179	5
	50	211-180	6
Stainless steel 304/1.4301	10	211-181	5
	16	211-182	5
	25	211-183	5
	40	211-184	5
	50	211-185	6

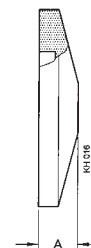

Flange with Tube, Short	DN ... ISO-KF	Part No.	A	B	C
Steel -/1.0037	10	211-201	20	12	16
	16	211-202	20	16	20
	25	211-203	20	26	30
	40	211-204	20	41	45
	50	211-205	20	51	55
Stainless steel 304/1.4301	10	211-211	20	12	16
	16	211-212	20	16	20
	25	211-213	20	26	30
	40	211-214	20	41	45
	50	211-215	20	50	54

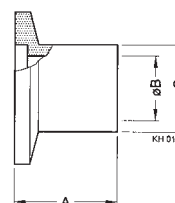

Flange with Tube, Long	DN ... ISO-KF	Part No.	A	B	C
Steel -/1.0037	10	211-206	70	12	16
	16	211-207	70	16	20
	25	211-208	70	26	30
	40	211-209	70	41	45
	50	211-210	70	51	55
Stainless steel 304/1.4301	10	211-216	70	12	16
	16	211-217	70	16	20
	25	211-218	70	26	30
	40	211-219	70	41	45
	50	211-220	70	50	54

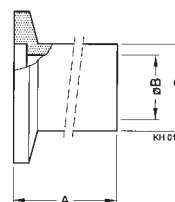

ISO-KF Small Flange Components

PIPE FITTINGS

Elbow 90°

	DN ... ISO-KF	Part No.	A	B
Aluminum 6082/-	10	211-251	30	12
	16	211-252	40	16
	25	211-253	50	25
	40	211-254	65	39
Stainless steel 304/1.4301	10	211-286	30	9
	16	211-287	40	15
	25	211-288	50	25
	40	211-289	65	40.5
	50	211-290	70	49

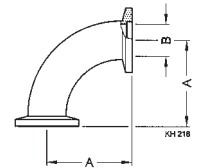
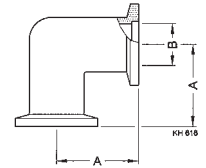

Elbow 45°

	DN ... ISO-KF	Part No.	A	B	C
Stainless steel 304/1.4301	16	211-307	26	55	15
	25	211-308	32	68.8	25
	40	211-309	40	87.7	37

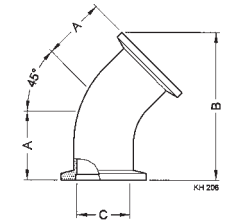

Tee

	DN ... ISO-KF	Part No.	A	B	C
Aluminum 6082/-	10	211-261	30	60	12
	16	211-262	40	80	16
	25	211-263	50	100	25
	40	211-264	65	130	39
Stainless steel 304/1.4301	10	211-291	30	60	12
	16	211-292	40	80	16
	25	211-293	50	100	25
	40	211-294	65	130	40.5
	50	211-295	70	140	53

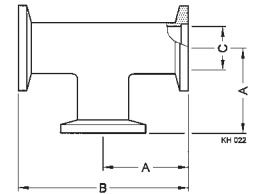

Reducing Tee

	DN ... ISO-KF	Part No.	A	B	C
Stainless steel 304/1.4301	25/16	211-316	50	100	40
	40/16	211-317	65	130	40
	40/25	211-318	65	130	50
	50/16	211-319	70	140	50
	50/25	211-320	70	140	65
	50/40	211-321	70	140	65

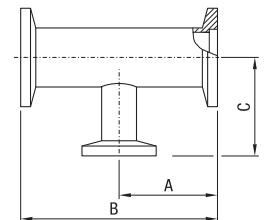

PIPE FITTINGS - continued

Cross

	DN ... ISO-KF	Part No.	A	B	C
Aluminum 6082/3.2315	10	211-266	30	60	12
	16	211-267	40	80	16
	25	211-268	50	100	25
	40	211-269	65	130	39
Stainless steel 304/1.4301	10	211-296	30	60	12
	16	211-297	40	80	16
	25	211-298	50	100	25
	40	211-299	65	130	40.5
	50	211-300	70	140	53

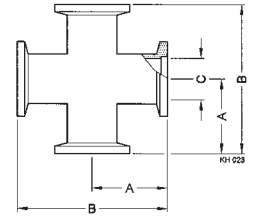
Reducing Cross

	DN ... ISO-KF	Part No.	A	B	C	D	E	F
Aluminum 6082/3.2315	25	211-271	35	70	35	70	25	16
	40	211-272	40	80	45	90	39	16
Stainless steel 304/1.4301	25	211-301	35	70	35	70	25	17
	40	211-302	40	80	45	90	40.5	16
	50	211-303	50	100	50	100	53	16

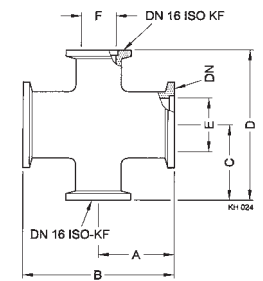
Intermediate Piece

	DN ... ISO-KF	Part No.	A	B
Aluminum 6082/-	16	211-227	80	16
	25	211-228	100	25
	40	211-229	130	40
Stainless steel 304/1.4301	16	211-277	80	16
	25	211-278	100	25
	40	211-279	130	40.5
	50	211-280	140	53

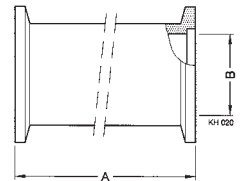
Reducer

	DN ... ISO-KF	Part No.	A	B
Aluminum 6082/-	25/16	211-231	40	16
	40/16	211-232	40	16
	40/25	211-233	40	25
	50/40	211-234	40	40
Stainless steel 303/1.4305	25/16	211-281	40	16
	40/16	211-282	40	16
	40/25	211-283	40	26
	50/40	211-284	40	40

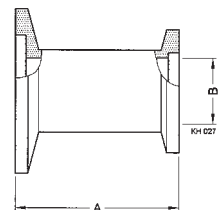

ISO-KF Small Flange Components

BELLOWS/HOSE WITH FLANGES

Bellows

	DN ... ISO-KF	Part No.	A	B	C	D
Flanges: Stainless steel 304/1.4301	10	211-326	70	3.5	3	23°
Bellow: Stainless steel 316Ti/-	16	211-327	70	6.4	4.1	21°
	25	211-328	80	8	5	17°
A = unstressed length	40	211-329	100	11	7	15°
D = max. deviation from axis	50	211-330	100	10	6	15°
Max. internal pressure: 4 bar						

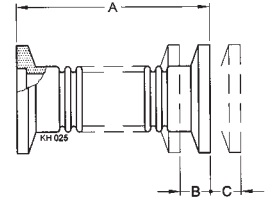

Metal Hose

	DN ... ISO-KF	Part No.	A	B	C
Flanges: Stainless Steel 304/1.4301	10	211-331	250	70	32
Bellow: Stainless steel 316Ti/-	10	211-332	500	70	32
	10	211-333	750	70	32
	10	211-334	1000	70	32
	16	211-335	250	70	50
	16	211-336	500	70	50
	16	211-337	750	70	50
	16	211-338	1000	70	50
	25	211-339	250	100	60
	25	211-340	500	100	60
	25	211-341	750	100	60
	25	211-342	1000	100	60
	40	211-343	250	130	100
	40	211-344	500	130	100
	40	211-345	750	130	100
	40	211-346	1000	130	100
Max. internal pressure: 4 bar	50	211-347	250	200	130
B = radius for multiple bending	50	211-348	500	200	130
C = radius for single bend	50	211-349	750	200	130
	50	211-350	1000	200	130

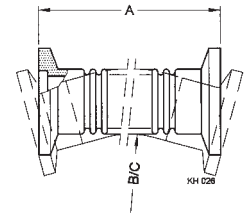

Metal Hose, Flexible

	DN ... ISO-KF	Part No.	A	B	C
Flanges: Stainless steel 304/1.4301	16	211-515	250	40	25
Bellow: Stainless steel 316Ti/-	16	211-516	500	40	25
	25	211-519	250	55	36
	25	211-520	500	55	36
	40	211-523	250	90	60
Max. internal pressure: 2 bar	40	211-524	500	90	60
B = radius for multiple bending	50	211-527	250	100	65
C = radius for single bend	50	211-528	500	100	65

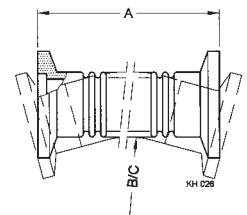

BELLOWS/HOSE WITH FLANGES - continued

PVC Hose		DN ... ISO-KF	Part No.	A	B	C
Hose:	PVC with cast in steel spiral	16	211-406	500	130	65
Nipple:	Aluminum 6082/-	16	211-407	1000	130	65
Hose clamp:	Stainless steel 430/-	25	211-408	500	200	100
		25	211-409	1000	200	100
B = radius for multiple bending		40	211-410	500	260	130
C = radius for single bend		40	211-411	1000	260	130

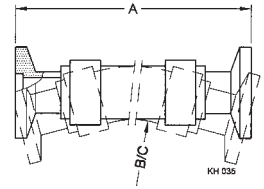

ISO-KF Small Flange Components

TRANSITION PIECES

Adapter ISO-KF/ISO-K

	ISO-KF/ISO-K	Part No.	A
Aluminum 6082/-	40/63	212-171	40
	50/63	212-172	45
Stainless steel 303/1.4305	40/63	212-173	40
	50/63	212-174	45
	40/100	212-175	40

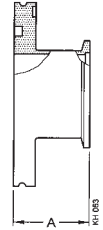

Adapter ISO-KF/CF-F

	ISO-KF/CF-F	Part No.	A	B
Stainless steel 304/1.4301	16/16	213-251	35	16
	25/16	213-252	35	16
	16/40	213-254	30	16
	25/40	213-255	30	26
	40/40	213-256	50	37
	40/63	213-259	35	41
	40/100	213-262	50	41

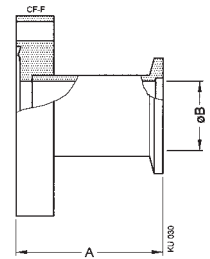

Adapter ISO-KF/VCR Female

	ISO-KF/VCR	Part No.	A
Flange: Stainless steel 304/1.4301	16/ 1/4"	211-359	35.8
Nut: Stainless steel 316L/1.4435	25/ 1/4"	211-480	35.8
	25/ 1/2"	211-360	40.6
Width across flats in inch	40/ 3/4"	211-361	53.3

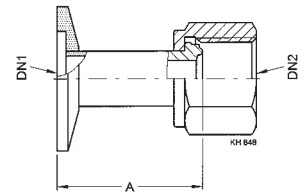

Adapter ISO-KF/VCR Male

	ISO-KF/VCR	Part No.	A
Flange: Stainless steel 304/1.4301	16/ 1/4"	211-362	35.8
Nut: Stainless steel 316L/1.4435	25/ 1/4"	211-481	35.8
	25/ 1/2"	211-363	40.6
Width across flats in inch	40/ 3/4"	211-364	53.3

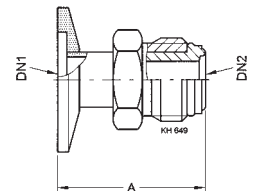

TRANSITION PIECES - continued

Adapter ISO-KF/Swagelok

	ISO-KF/Swagelok	Part No.	A	B
Flange: Stainless steel 304/1.4301	16/6 mm	211-356 ¹⁾	37	15.3
Nut: Stainless steel 316L/1.4435	25/10 mm	211-357 ¹⁾	45	17.2
	40/16 mm	211-358 ¹⁾	53	24.4
	16/ 1/8"	211-476 ²⁾	34.5	12.7
	25/ 1/4"	211-477 ²⁾	37	15.3
	40/ 1/4"	211-478 ²⁾	37	15.3
	40/ 1/2"	211-479 ²⁾	47.5	22.8

¹⁾ Width across flats metric (SI)

²⁾ Width across flats in inch

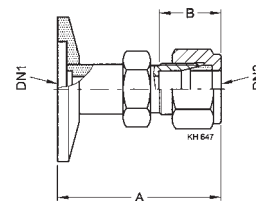

Glass Tube Connection

	DN ... ISO-KF	Part No.	A	B	C	D
Flange: Aluminum 6082/-	10	211-351	50	8	10	30
Sealing: Elastomer FPM	40	211-353	65	22	26	45
Tube: Glas Pyrex						

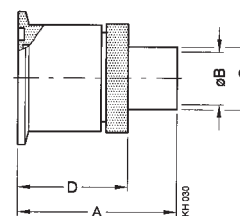

Screw-in Flange

	ISO-KF/DN	Part No.	A	B	C	D
Flange: Stainless steel 303/1.4305	10/ G 3/8"	211-366	35	15	G 3/8"	12
Sealing: Elastomer FPM	16/ G 1/2"	211-367	35	15	G 1/2"	16
	25/ G 1"	211-368	45	25	G 1"	25
Width across flats metric (SI)	40/ G 1 1/2"	211-369	50	30	G 1 1/2"	41

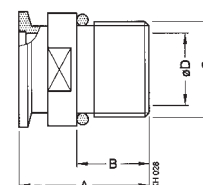

Screw-on Flange

	ISO-KF/DN	Part No.	A	B	C	D
Flange: Stainless steel 303/1.4305	10/ G 3/8"	211-376	35	15	G 3/8"	10
Sealing: Elastomer FPM	16/ G 1/2"	211-377	35	15	G 1/2"	15
	25/ G 1"	211-378	45	25	G 1"	24
Width across flats metric (SI)	40/ G 1 1/2"	211-379	50	30	G 1 1/2"	38

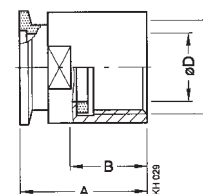

TRANSITION PIECES - continued

Adapter ISO-KF/NPT Female

	ISO-KF/NPT	Part No.	A	B	C	D
Stainless steel 303	16/ 1/8"	211-566	19	10	12	1/8-27 NPT
	16/ 1/4"	211-567	19	13	15	1/4-18 NPT
	25/ 1/8"	211-569	19	10	12	1/8-27 NPT
	25/ 1/4"	211-570	19	13	15	1/4-18 NPT
	25 / 1/2"	211-571	26	18	25	1/2-14 NPT
	25 / 1"	211-572	42	24	25	1-11 1/2 NPT
	40 / 1/4"	211-574	19	13	15	1/4-18 NPT
	40 / 1/2"	211-575	26	18	25	1/2-14 NPT
Width across flats in inch	40 / 1"	211-576	26	23	41	1-11 1/2 NPT

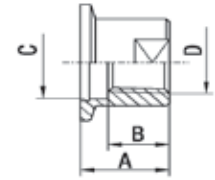

Adapter ISO-KF/NPT Male

	ISO-KF/NPT	Part No.	A	B	C	D	
Stainless steel 303 / 1.4305	16/ 1/8"	211-551	40	17	5	1/8-27 NPT	
	16/ 1/4"	211-552	40	22	7	1/4-18 NPT	
	25/ 1/8"	211-554	40	17	5	1/8-27 NPT	
	25/ 1/4"	211-555	40	22	7	1/4-18 NPT	
	25 / 1/2"	211-556	50	30	14	1/2-14 NPT	
	25 / 1"	211-557	60	32	25	1-11 1/2 NPT	
	40 / 1/4"	211-559	40	21	7	1/4-18 NPT	
	40 / 1/2"	211-560	50	30	14	1/2-14 NPT	
	40 / 1"	211-561	60	33	25	1-11 1/2 NPT	
		40 / 1 1/4"	211-562	50	31.5	32	1 1/4-11 1/2 NPT
		40 / 1 1/2"	211-563	50	28	32	1 1/2-11 1/2 NPT
	Width across flats in inch	40 / 2"	211-564	50	27	40	2-11 1/2 NPT

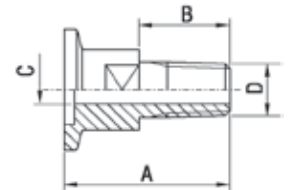

ISO-KF Small Flange Components

HOSE, HOSE CONNECTION

Hose Adapter 90°

	DN ... ISO-KF	Part No.	A	B	C	D
Aluminum 6082/-	16	211-257	40	40	16	13
	25	211-258	50	50	25	22
	40	211-259	65	65	40	37

C = nominal connection for sleeve / hose

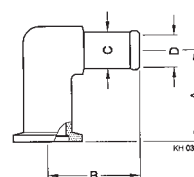

Hose Adapter for Rubber Hose

	DN ... ISO-KF	Part No.	A	B	C
Aluminum 6082/-	16	211-387	40	7	12
	25	211-388	40	7	12
	40	211-389	40	7	12
Stainless steel 303/1.4305	16	211-392	40	7	12
	25	211-393	40	7	12
	40	211-394	40	7	12

C = nominal connection for hose

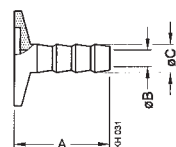

Hose Connection

	DN ... ISO-KF	Part No.	A	B	C
Aluminum 6082/-	25	211-401	40	13	16
	16	211-402	40	13	16
	25	211-403	40	22	25
	40	211-404	40	37	40

C = nominal connection for sleeve / hose

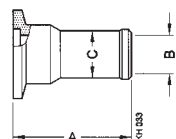

Sleeve with Hose Clamp

	DN ... ISO-KF	Part No.	A	B	C	D	E
Hose clamp: Stainless steel 430/-	16	211-417	58	7	14	16	44
Sleeve: Elastomer CR	25	211-418	60	9	16	25	50
Max. internal pressure: 1 bar	40	211-419	64	13	20	40	68

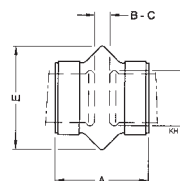

Hose Clamp

	DN ... ISO-KF	Part No.	A	B
Stainless steel 430/-	16	211-461	13	32
	25	211-462	19	44
	40	211-463	29	76

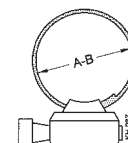

HOSE, HOSE CONNECTION - continued

PVC Hose

	DN ... ISO-KF	Part No.	A	B	C
With cast in spiral	16	211-442	23	16	130
	25	211-443	33	25	200
For vacuum applications Indicate length in meters	40	211-444	53	40	260

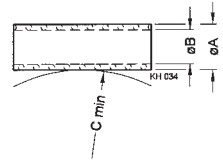

Rubber Hose

	DN ... ISO-KF	Part No.	A	B
For vacuum applications	10	211-451	17	7
Indicate length in meters	16	211-452	25	10
Hardness: 55 ± 5 Shore A Temperature: -30 to +85 °C	20	211-453	32	16

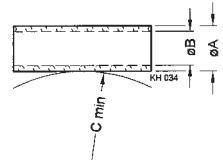

Protective Lid

	DN ... ISO-KF	Part No.	A	B	C
Polyethylene	10-16	211-427	32	29	7.5
	20-25	211-428	42	39	7.5
	32-40	211-429	57	54	7.5
	50	211-430	77	74	7.5

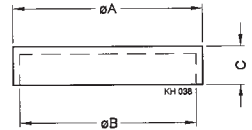

ISO-K Clamp Flange Components

CONNECTION ELEMENTS

Clamp	DN ... ISO-K	Part No.	A	B	C	Set of
Steel zinc plated 103/-	63-250	212-225	60	17	27	4 pcs.
	320-500	212-226	78	27	39	4 pcs.
	630	212-227	88	31	49	4 pcs.
Stainless steel 316/-	63-250	212-228	61	18	28	4 pcs.
	320-630	212-240	82	29	47	4 pcs.

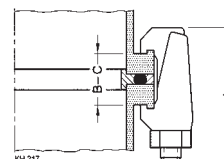

Claw	DN ... ISO-K	Part No.	A	B	C	Set of
Clamping flange / base plate	63-100	212-231	22.5	35	13.9	4 pcs.
	160-250	212-232	23	35	13.9	4 pcs.
	320-500	212-233	36.5	50	20.6	4 pcs.
	630	212-234	41.5	55	25.6	4 pcs.
Clamping flange/ base plate with groove	63-100	212-235	18.6	30	10	4 pcs.
	160-250	212-236	19	35	10	4 pcs.
	320-500	212-237	31	45	15	4 pcs.
	630	212-233	36.5	50	20.6	4 pcs.
Clamping flange with groove / base plate	63-100	212-247	20.6	30	12	4 pcs.
	160-250	212-248	21.1	35	12	4 pcs.
	320-500	212-249	33.9	45	18	4 pcs.
	630	212-233	36.5	50	20.6	4 pcs.
Steel zinc plated 103/-						

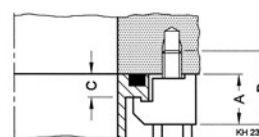
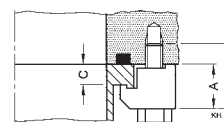
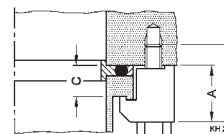

ISO-K Clamp Flange Components

SEALS

Centering Ring		DN ... ISO-K	Part No.	A	B	C	D
Inner & outer ring:	Aluminum 6082/-	63	212-251	96	70	3.9	8
Seal:	Elastomer CR	80	212-091	109	83	3.9	8
		100	212-252	128	102	3.9	8
		160	212-253	179	153	3.9	8
		200	212-254	239	213	3.9	8
		250	212-255	287	261	3.9	8
		320	212-256	358	318	5.6	14
		400	212-257	440	400	5.6	14
		500	212-258	541	501	5.6	14
		630	212-259	691	651	5.6	14
Inner & outer ring:	Aluminum 6082/-	63	212-261	96	70	3.9	8
Seal:	Elastomer FPM	80	212-092	109	83	3.9	8
		100	212-262	128	102	3.9	8
		160	212-263	179	153	3.9	8
		200	212-264	239	213	3.9	8
		250	212-265	287	261	3.9	8
		320	212-266	358	318	5.6	14
		400	212-267	440	400	5.6	14
		500	212-268	541	501	5.6	14
		630	212-269	691	651	5.6	14
		800	212-270	840	800	5.6	14
		1000	212-271	1040	1000	5.6	14
Inner ring:	Stainless steel 304/-	63	212-281	96	70	3.9	8
Outer ring:	Aluminum 6082/-	80	212-093	109	83	3.9	8
Seal:	Elastomer FPM	100	212-282	128	102	3.9	8
		160	212-283	179	153	3.9	8
		200	212-284	239	213	3.9	8
		250	212-285	287	261	3.9	8

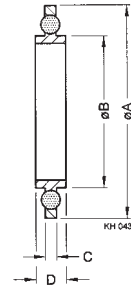

SEALS - continued

Centering Ring with Fine Filter

	DN ... ISO-K	Part No.	A	B	C	D
Inner ring: Stainless steel 304/-	63	212-291	62	69.8	3.9	8
Outer ring: Aluminum 6082/-	100	212-292	94	101.8	3.9	8
Seal: Elastomer FPM						
Snap ring: Stainless steel 304/-						
Filter grit: Stainless steel 304/-						
Filter: Stainless steel 316L/-						
Pore size 0.004 mm						
Degree of separation at 0.001 mm up to 98%						

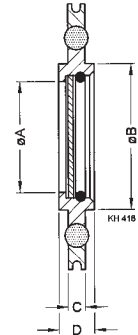

O-Ring

	DN ... ISO-K	Part No.	A	B	Set of
Elastomer CR	63	212-386	75.6	5.3	5 pcs.
	80	212-387	88.3	5.3	5 pcs.
	100	212-388	107.3	5.3	5 pcs.
	160	212-389	158.1	5.3	5 pcs.
	200	212-390	208.9	5.3	5 pcs.
	250	212-391	253.4	5.3	5 pcs.
	320	212-356	329.6	7	
	400	212-357	405.3	7	
	500	212-358	506.9	7	
Elastomer FPM	63	212-392	75.6	5.3	5 pcs.
	80	212-393	88.3	5.3	5 pcs.
	100	212-394	107.3	5.3	5 pcs.
	160	212-395	158.1	5.3	5 pcs.
	200	212-396	208.9	5.3	5 pcs.
	250	212-397	253.4	5.3	5 pcs.
Elastomer FPM	320	212-366	329.6	7	
	400	212-367	405.3	7	
	500	212-368	506.9	7	
	630	212-369	658.9	7	
	800	212-370	808	7	
	1000	212-371	1006	7	

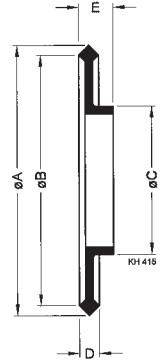

SEALS - continued

Aluminum Seal		DN ... ISO-K	Part No.	A	B	C	D	E	
Aluminum annealed 6082/-	63	212-301	85.6	83	69.8	2.6	4.5		
	100	212-302	116.6	114	101.8	2.6	4.5		
	160	212-303	166.6	164	152.8	2.6	4.5		
	250	212-305	276.6	274	260.8	2.6	4.5		
Number of		Clamps	Claw Grips						
	DN 63 ISO -K	4							
	DN 100 ISO-K	6							8
	DN 160 ISO-K	8							8
	DN 250 ISO-K	12							12



ISO-K Clamp Flange Components

FLANGES

Blank Flange	DN ... ISO-K	Part No.	A	B
Steel nickel plated A570/-	63	212-001	95	12
	100	212-002	130	12
	160	212-003	180	12
	250	212-005	290	12
Stainless steel 304/-	63	212-011	95	12
	80	212-076	110	12
	100	212-012	130	12
	160	212-013	180	12
	200	212-014	240	12
	250	212-015	290	12
	320	212-016	370	17
	400	212-017	450	17
	500	212-018	550	17
630	212-019	690	22	

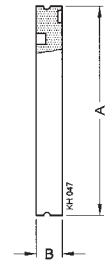

Welding Flange	DN ... ISO-K	Part No.	A	B	C	D	E
Steel -/1.0570	63	212-021	95	76.1	70.3	12	6
	100	212-022	130	108	102.2	12	6
Steel A570/-	160	212-023	180	159	153.2	12	6
	250	212-025	290	267	261	12	6
Stainless steel 304/-	63	212-031	95	76.1	71.5	12	6
	80	212-078	110	88.9	84.9	12	6
	100	212-032	130	108	102	12	6
	160	212-033	180	159	155	12	6
	200	212-034	240	219.1	213.9	12	6
	250	212-035	290	267	261	12	6

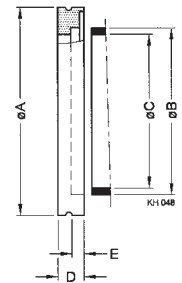

FLANGES - continued

Flange with Tube

	DN ... ISO-K	Part No.	A	B	C
Flange: Steel -/1.0570	63	212-041	100	76.1	70.3
Tube: Steel -/1.0831	100	212-042	100	108	102.2
	160	212-043	100	159	153.2
	250	212-045	100	267	261
	320	212-046	100	324	318
	400	212-047	100	406	400
	500	212-048	100	508	500
	630	212-049	100	660	650
Stainless steel 304/-	63	212-051	100	76.1	71.5
	100	212-052	100	108	104
	160	212-053	100	159	155
	200	212-054	100	219.1	213.1
	250	212-055	100	267	261
	320	212-056	100	324	318
	400	212-057	100	406	400
	500	212-058	100	508	500
	630	212-059	100	660	650

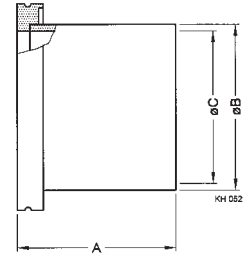

ISO-K Clamp Flange Components

PIPE FITTINGS

Elbow 90°

	DN ... ISO-K	Part No.	A	B
Stainless steel 304/-	63	212-101	88	66
	100	212-102	108	100
	160*	212-103	138	150
	200*	212-104	178	213
	250*	212-105	208	250
	320*	212-106	250	318

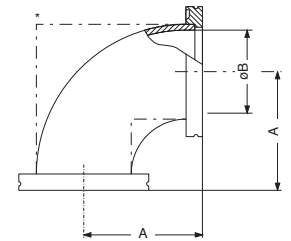

Tee

	DN ... ISO-K	Part No.	A	B
Stainless steel 304/-	63	212-111	88	66
	100	212-112	108	100
	160	212-113	138	150
	200	212-114	178	213
	250	212-115	208	250
	320	212-116	250	318

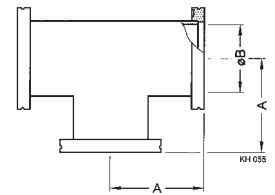

Reducing Tee

	DN ... ISO-K	Part No.	A	B	C
Stainless steel 304/-	160/63	212-196	138	276	130
	160/100	212-197	138	276	131
	250/200	212-198	190	380	208

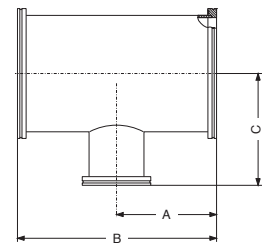

Reducer

	DN ... ISO-K	Part No.	A
Stainless steel 303/-	80/63	212-084	50
	100/63	212-161	50
	160/100	212-163	50
	250/200	212-170	50

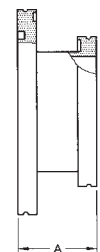

PIPE FITTINGS - continued

Intermediate Piece	DN ... ISO-K	Part No.	A	B
Stainless steel 304/-	63	212-191	100	70
	63	212-192	176	70

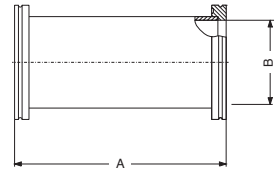

Cross	DN ... ISO-K	Part No.	A	B
Stainless steel 304/-	63	212-121	88	66
	100	212-122	108	100
	160	212-123	138	150
	200	212-124	178	213
	250	212-125	208	250

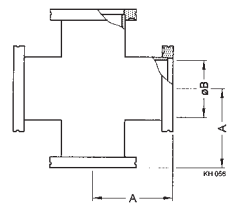

Reducing Cross	DN ... ISO-K	Part No.	A	B	C	D	E
Stainless steel 304/-	63	212-131	88	44	66	64	59
	100	212-132	100	50	82	80	77
	160	212-133	100	50	107	107	105

1 x DN 16 ISO-KF, 1 x DN 25 ISO-KF, 1 x DN 40 ISO-KF

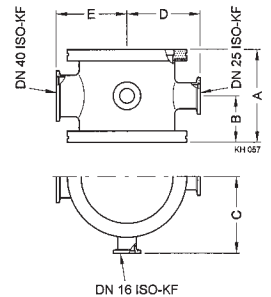

ISO-K Clamp Flange Components

BELLOWS / HOSE WITH FLANGES

Bellows	DN ... ISO-K	Part No.	A	B	C	D	E
Flanges: Stainless steel 304/-	63	212-201	132	20	20	66	30°
Bellow: Stainless steel 316Ti/-	100	212-202	132	28	28	95	30°
	160	212-203	150	22	22	153	14°
	200	212-204	150	20	20	213	12°
E = max. deviation from axis	250	212-205	200	30	30	261	13°
Max. internal pressure 1.5 bar	320	212-206	250	50	50	313	12°

A = unstressed length

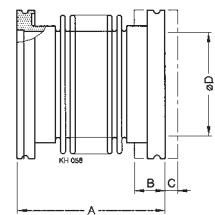

Metal Hose	DN ... ISO-K	Part No.	A	B	C
Flanges: Stainless steel 304/-	63	212-211	250	250	160
Bellow: Stainless steel 316Ti/-	63	212-212	500	250	160
	63	212-213	750	250	160
	63	212-214	1000	250	160
	100	212-215	250	370	240
	100	212-216	500	370	240
	100	212-217	750	370	240
Max. internal pressure 1.5 bar	100	212-218	1000	370	240

B = radius for multiple bending

C = radius for single bending

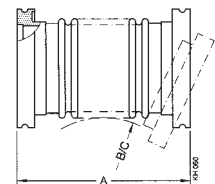

ISO-K Clamp Flange Components

TRANSITION PIECES

Adapter Flange

	ISO-K / ISO-F	Part No.	A
Stainless steel 304/-	160/63	212-152	22
	160/100	212-153	25
	200/100	212-155	20
	200/160	212-156	25
	250/160	212-159	22

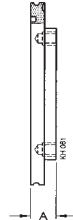

Adapter

	ISO-K / ISO-KF	Part No.	A
Aluminum 6082/-	63/40	212-171	40
	63/50	212-172	45
Stainless steel 303/-	63/25	212-176	50
	63/40	212-173	40
	63/50	212-174	45
	100/40	212-175	40

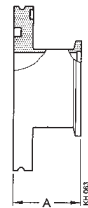

Adapter

	ISO-CF / ISO-K	Part No.	A	B	C
Stainless steel 304/-	63/63	213-271	90	1	1
	100/100	213-272	90	1	1
	160/160	213-273	90	1.5	1.5

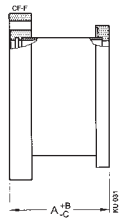

Adapter

	DN ... ISO-K	Part No.	A	B
Aluminum 6082/-	63	212-181	51	76
	100	212-182	56	107
	160	212-183	56	156

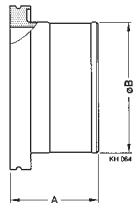

Sleeve with Hose Clamp

	DN ... ISO-KF	Part No.	A	B	C	D	E
Sleeve: Elastomer CR	63	212-186	70	14	24	75	120
Hose clamp: Stainless steel 430/-	100	212-187	72	8	26	106	150
Max. internal pressure: 1 bar	160	212-188	72	8	26	155	200

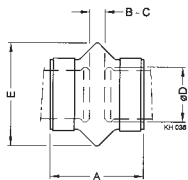

ISO-K Clamp Flange Components

PROTECTIVE LIDS

Protective Lids	DN ... ISO-K	Part No.	A	B	C
Polyethylene	63	212-311	102	95	18
	100	212-312	137	130	18
	160	212-313	187	180	18
	200	212-314	248	240	18.5
	250	212-315	297.5	290	18.5
	320	212-316	380	370	23.5
	400	212-317	461	450	23.5
	500	212-318	557	550	24
	630	212-319	697	690	29

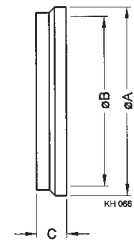

ISO-F Fixed Flange Components

FLANGE COMPONENTS

Collar Flange with Retaining Ring

	DN ... ISO-F	Part No.	A	B	C	
Flange: Steel nickel plated	-1.0570	63	212-061	12	95.5	130
Retaining Ring: Steel nickel plated		100	212-062	12	130.5	165
		160	212-063	16	180.7	225
		200	212-064	16	240.7	285
		250	212-065	16	290.7	335
		320	212-066	20	370.8	425
		400	212-067	20	450.8	510
		500	212-068	20	550.8	610
		630	212-069	24	691	750

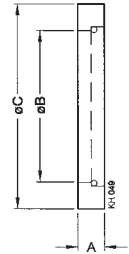

Adapter Flange with ISO-K / ISO-F

	DN ... ISO-F	Part No.	A
Stainless steel 304/1.4301	160/63	212-152	22
	160/100	212-153	25
	200/100	212-155	20
	200/160	212-156	25
	250/160	212-159	22

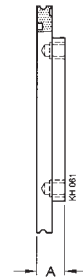

Measurement Flange

	DN ... ISO-F	Part No.	A	B	C
Aluminum 6082/3.2315	100	212-142	30	165	M 8
	160	212-143	30	225	M 10
Stainless steel 304/1.4301	63	212-146	30	130	M 8
	100	212-147	30	165	M 8
	160	212-148	30	225	M 10

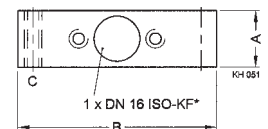

*Claw grip DN 16 ISO-KF included

FLANGE COMPONENTS - continued

Set of Hexagon Bolts

	DN ... ISO-F	Part No.	A	B	Set of
Steel zinc plated	63-100	212-241	40	8	8 pcs.
	160-250	212-242	50	10	12 pcs.
	320-500	212-243	70	12	16 pcs.
	630	212-244	80	12	20 pcs.

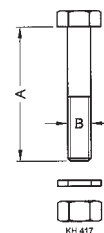

Sealing Disk

	DN ... ISO-F	Part No.	A	B	C
Disk: Aluminum 6082/3.2315	63	212-321	73	3.9	98
O-ring: Elastomer CR	100	212-322	107	3.9	132
	160	212-323	160	3.9	185
	250	212-325	270	3.9	295
	320	212-326	330	5.6	375
	400	212-327	415	5.6	460
	500	212-328	515	5.6	560
	630	212-329	656	5.6	701
	800	212-330	825	5.6	870
	1000	212-331	1025	5.6	1070

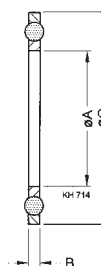

O-Ring

	DN ... ISO-F	Part No.	A	B	Set of
Elastomer CR	63	212-345	80	5	5 pcs.
	100	212-346	110	5	5 pcs.
	160	212-347	165	5	5 pcs.
	250	212-349	265	5	5 pcs.
	320	212-338	325	8	5 pcs.
	400	212-339	412	8	
	500	212-340	510	8	
	630	212-341	640	8	
	800	212-342	820	8	
	1000	212-343	1023	8	



UHV CF Components

CONNECTION ELEMENTS

Hexagon Bolts with Nuts

		DN ... CF	Part No.	A	B	Set of	Required torque
Bolt:	Stainless steel 316/1.4401	16	213-401	20	3.2	25 x M4	3.5 Nm
Washer:	Stainless steel 304/1.4301	40	213-402	35	5	25 x M6	10 Nm
Nut:	Stainless steel 316/1.4401	63	213-403	45	6.5	25 x M8	20 Nm
		100	213-404	50	6.5	25 x M8	20 Nm
		160	213-405	55	6.5	25 x M8	20 Nm
		200-250	213-406	60	6.5	25 x M8	20 Nm
		300	213-408	70	8	34 x M10	30 Nm
		350	213-409	70	8	38 x M10	30 Nm

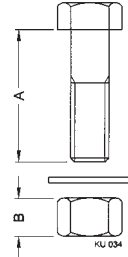

Hexagon Bolts without Nuts

		DN ... CF	Part No.	A	Set of	Required torque
Bolt:	Stainless steel 316/1.4401	16	213-411	16	25 x M4	4 Nm
Washer:	Stainless steel 304/1.4301	40	213-412	25	25 x M6	10 Nm
		63-160	213-413	35	25 x M8	20 Nm

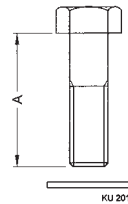

Hexagon Bolts with Duo Nuts

		DN...CF	Part No.	A	B	C	Duo nut	Required torque
Bolt:	Stainless steel 316/1.4401	16	213-421	20	7	4	6 x M4/3	4 Nm
Washer:	Stainless steel 304/1.4301	40	213-422	35	10	5	6 x M6/3	10 Nm
Duo nut:	Stainless steel 316/1.4401	63	213-423	45	12	8	8 x M8/3	20 Nm
		100	213-424	50	12	8	16 x M8/8	20 Nm
		160	213-425	55	12	8	20 x M8/10	20 Nm

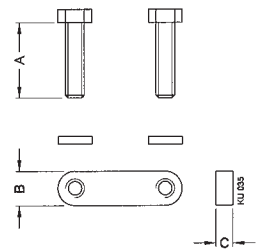

Set of Stud Screws

		DN ... CF	Part No.	A	Set of	Required torque
Bolt:	Stainless steel 316/1.4401	16	213-431	20	6 x M4	4 Nm
Washer:	Stainless steel 304/1.4301	40	213-432	35	6 x M6	10 Nm
Nut:	Stainless steel 316/1.4401	63-100	213-433	45	16 x M8	20 Nm

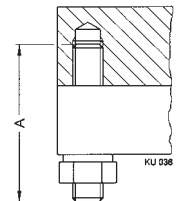

Thread Lubricant

		Part No.	Temperature resistance
C100	28g	214-231	1000°C

Remains fully effective for at least 10 bakeout cycles

UHV CF Components

SEALS

Quality copper gaskets and silver plated copper gaskets are strictly designed for use in high-end UHV applications. These gaskets, made of OFHC copper, are inspected, cleaned and individually packed to ensure maximum quality.

Copper Gasket	DN ... CF	Part No.	A	B	C	Set of
High quality	16	213-451	2.1	21.3	16.2	10 pcs.
Copper OFHC -/2.0040	40	213-452	2.1	48.1	39	10 pcs.
Individually packed	63	213-453	2.1	82.4	63.6	10 pcs.
	100	213-454	2.1	120.5	101.8	10 pcs.
	160	213-455	2.1	171.3	152.6	10 pcs.
	200	213-456	2.1	222.1	203.4	10 pcs.
	250	213-457	2.1	272.9	254.2	5 pcs.
	300	213-458	2.1	326.2	307	1 pcs.
	350	213-459	2.1	376.5	357	1 pcs.

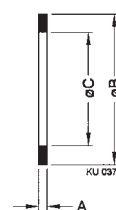

Copper Gasket Silver Plated	DN ... CF	Part No.	A	B	C	Set of
High quality	16	213-461	2.1	21.3	16.2	10 pcs.
Individually packed	40	213-462	2.1	48.1	39	10 pcs.
Copper OFHC -/2.0040	63	213-463	2.1	82.4	63.6	10 pcs.
Double silver plated	100	213-464	2.1	120.5	101.8	10 pcs.
	160	213-465	2.1	171.3	152.6	5 pcs.
	200	213-466	2.1	222.1	203.4	5 pcs.
	250	213-467	2.1	272.9	254.2	5 pcs.

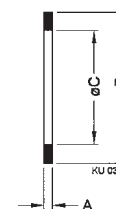

SEALS - continued

FPM Seal		DN ... CF	Part No.	A	B	C	D	Set of
Elastomer FPM	16	213-391	2	21	16			5 pcs.
	40	213-392	2.5	48.2	42			5 pcs.
	63	213-393	3.2	82.7	69.7	2.5		2 pcs.
	100	213-394	3.2	119.8	107.8	2.5		2 pcs.
	160	213-395	3.2	171.1	156	2.5		2 pcs.
	200	213-396	3.2	222.5	206	2.5		2 pcs.

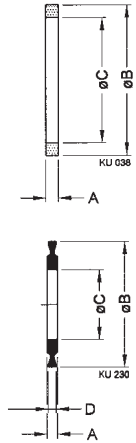

FPM Seal with Support Ring		DN ... CF	Part No.	A	B	C	D	Set of
Seal:	Elastomer FPM	250	213-397	5	266.5	248.3	256.2	1 pcs.
Support ring: Aluminum 6082/-								

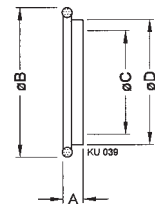

UHV CF Components

FLANGES

Blank Flange

	DN ... CF-F	Part No.	A	B	C
Stainless steel 304/1.4301	16	213-001	7.5	14	1.4
	40	213-002	13	38	1.4
	63	213-003	17.5	66	1.4
	100	213-004	20	104	1.4
	160	213-005	22	155	1.4
	200	213-006	24.5	205	1.4
	250	213-007	240.5	256	1.4
Stainless steel 316L/1.4435	300	213-008	28.5	306	1.4
	350	213-009	28.5	356	1.4
Stainless steel 316LN/1.4429	16	213-101	7.5	14	1.4
	40	213-102	13	38	1.4
	63	213-103	17.5	66	1.4
	100	213-104	20	104	1.4
	160	213-105	22	155	1.4
	200	213-106	24.5	205	1.4
	250	213-107	24.5	256	1.4

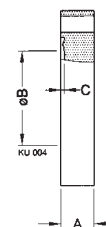

Blank Flange, Rotatable

	DN ... CF-R	Part No.	A	B	C	D	E
Stainless steel 304/1.4301	16	213-011	7.5	5.8	18.6	14	1.4
	40	213-012	13	7.6	41	38	1.4
	63	213-013	17.5	12.6	71	66	1.4
	100	213-014	20	14.3	109	104	1.4
	160	213-015	22	15.8	160	155	1.4
	200	213-016	24.5	17.1	206	205	1.4
	250	213-017	24.5	18	257	256	1.4
Stainless steel 316LN/1.4429	16	213-111	7.5	5.8	18.6	14	1.4
	40	213-112	13	7.6	41	38	1.4
	63	213-113	17.5	12.6	71	66	1.4
	100	213-114	20	14.3	109	104	1.4
	160	213-115	22	15.8	160	155	1.4
	200	213-116	24.5	17.1	206	205	1.4
	250	213-117	24.5	18	257	256	1.4

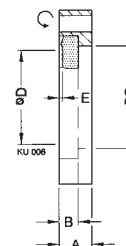

FLANGES – continued

Welding Flange

	DN ... CF-F	Part No.	A	B	C	D	E
Stainless steel 304/1.4301	16	213-021	7.5	3.3	17.2	18	1
	40	213-022	13	7.5	39.5	40	1.5
	63	213-023	17.5	8	66	70	2
	100	213-024	20	9	104	108	2
	160	213-025	22	10	155	159	2
	200	213-026	24.5	12	205	205	2.5
	250	213-027	24.5	12	256	256	3
Stainless steel 316L/1.4435	300	213-028	28.5	15.8	306	306	3
	350	213-029	28.5	15.8	356	356	3
Stainless steel 316LN/1.4429	16	213-121	7.5	3.3	17.2	18	1
	40	213-122	13	7.5	39.5	40	1.5
	63	213-123	17.5	8	66	70	2
	100	213-124	20	9	104	108	2
	160	213-125	22	10	155	159	2
	200	213-126	24.5	12	205	205	2.5
	250	213-127	24.5	12	256	256	3

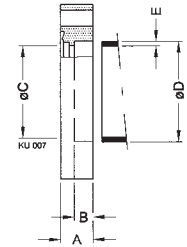

Welding Flange, Rotatable

	DN ... CF-R	Part No.	A	B	C	D	E
Stainless steel 304/1.4301	16	213-041	7.5	3.3	17.2	18	1
	40	213-042	13	7.5	39.5	40	1.5
	63	213-043	17.5	8	66	70	2
	100	213-044	20	9	104	108	2
	160	213-045	22	10	155	159	2
	200	213-046	24.5	12	205	205	2.5
	250	213-047	24.5	12	256	256	3
Stainless steel 316LN/1.4429	16	213-141	7.5	3.3	17.2	18	1
	40	213-142	13	7.5	39.5	40	1.5
	63	213-143	17.5	8	66	70	2
	100	213-144	20	9	104	108	2
	160	213-145	22	10	155	159	2
	200	213-146	24.5	12	205	205	2.5
	250	213-147	24.5	12	256	256	3

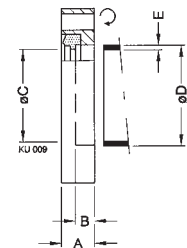

FLANGES - continued

Welding Flange with Tapped Holes

	DN ... CF-F	Part No.	A	B	C	D	E	
Stainless steel 304/1.4301	16	213-031	7.5	3.3	17.2	18	1	6xM4
	40	213-032	13	7.5	39.5	40	1.5	6xM6
	63	213-033	17.5	8	66	70	2	8xM8
	100	213-034	20	9	104	108	2	16x M8

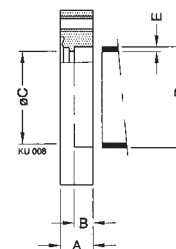

Welding Flange for Gauges

	DN ... CF-F	Part No.	A	B	C	D	E	F	G	F
Stainless steel 304/1.4301	40	213-092	24	17	38	69.5	1.75	48	10	4

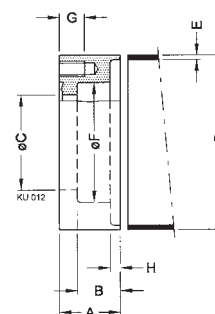

Flange with Tube

	DN ... CF-F	Part No.	A	B	C	D
Stainless steel 304/1.4301	16	213-051	38	17.2	18	1
	40	213-052	63	39.5	40	1.6
	63	213-053	105	66	70	2
	100	213-054	135	104	108	2
	160	213-055	167	155	159	2

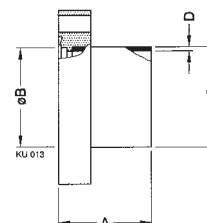

Flange with Tube, Rotatable

	DN ... CF-R	Part No.	A	B	C	D
Stainless steel 304/1.4301	16	213-061	38	17.2	18	1
	40	213-062	63	39.5	40	1.6
	63	213-063	105	66	70	2
	100	213-064	135	104	108	2
	160	213-065	167	155	159	2

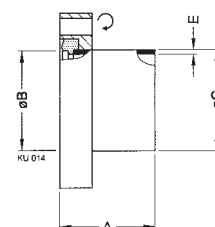

FLANGES - continued

**Reducing Flange
CF-F/CF-F**

	DN ... CF-F	Part No.	A	B	C	D	
Stainless steel 304/1.4301	40/16	213-071	13	16	22	5.5	6xM4
	63/40	213-073	17.5	39	50	9	6xM6
	100/40	213-075	20	39	55	9	6xM6
	100/63	213-076	20	66	85	11	8xM8
	160/40	213-078	22	39	60	9	6xM6
	160/100	213-080	22	104	120	11	16xM8
Stainless steel 316LN/1.4429	40/16	213-171	13	16	22	5.5	6xM4
	63/40	213-173	17.5	39	50	9	6xM6
	100/40	213-175	20	39	55	9	6xM6
	100/63	213-176	20	66	85	11	8xM8
	160/40	213-178	22	39	60	9	6xM6
	160/100	213-180	22	104	120	11	16xM8

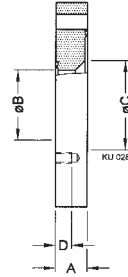

UHV CF Components

PIPE FITTINGS

Intermediate Piece

	DN ... CF	Part No.	A	B	C	D
Stainless steel 304/1.4301	16	213-201	76	0.5	0.5	16
	40	213-202	126	1	1	37
	63	213-203	210	1	1	104
	100	213-204	270	1	1	104
	160	213-205	334	1.5	1.5	155

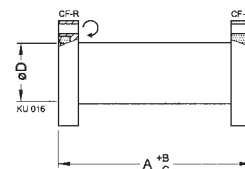

Intermediate Piece, Insulated

	DN ... CF	Part No.	A	B	C	D	E	F	G
Flanges: Stainless steel 304/1.4301	40	213-212	70	1	1	25	30	34.5	44
Insulator: Ceramic Al ₂ O ₃	63	213-213	90	1	1	53	45	66	65
Transition insulator/flange: FeNi									
Bakeout temperature: 350 °C									
G = Surface leakage 20 kV at 10 ⁻⁴ mbar									

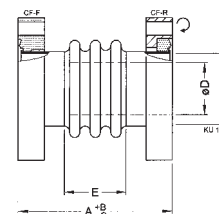

Reducer CF/CF

	DN ... CF	Part No.	A	B	C	D
Stainless steel 304/1.4301	40/16	213-221	45	1	1	16
	63/40	213-223	75	1	1	37
	100/40	213-225	75	1	1	37
	100/63	213-226	95	1	1	66
	160/100	213-230	105	1.5	1.5	104

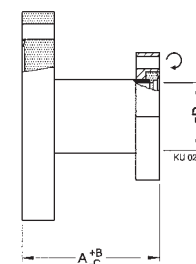

Elbow 90°

	DN ... CF	Part No.	A	B	C	D
Stainless steel 304/1.4301	16	213-301	38	0.5	0.5	15
	40	213-302	63	0.5	0.5	38
	63	213-303	105	1	1	66
	100	213-304	135	1	1	100
	160	213-305	167	1.5	1.5	150

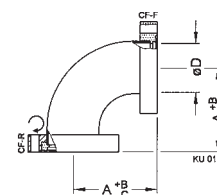

PIPE FITTINGS - continued

TEE

	DN ... CF	Part No.	A	B	C	D
Stainless steel 304/1.4301	16	213-311	38	0.5	0.5	15
	40	213-312	63	0.5	0.5	38
	63	213-313	105	1	1	66
	100	213-314	135	1	1	100
	160	213-315	167	1.5	1.5	150

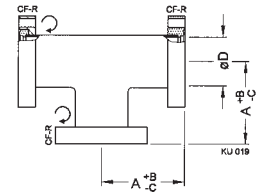

Cross

	DN ... CF	Part No.	A	B	C	D
Stainless steel 304/1.4301	16	213-321	38	0.5	0.5	15
	40	213-322	63	0.5	0.5	38
	63	213-323	105	1	1	66
	100	213-324	135	1	1	100
	160	213-325	167	1.5	1.5	150

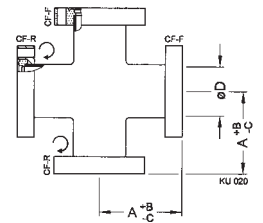

Double Cross Piece

	DN ... CF	Part No.	A	B	C	D
Stainless steel 304/1.4301	40	213-332	63	0.5	0.5	38
3 rotatable flanges	63	213-333	105	1	1	66
3 fix flanges	100	213-334	135	1	1	100
	160	213-335	167	1.5	1.5	150

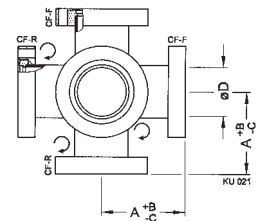

Reducing Cross

	DN ... CF	Part No.	A	B	C	D	E	F
Stainless steel 304/1.4301	100	213-342	135	1	1	67.5	106	84
2 x DN 16 CF-F								
2 x DN 40 CF-F								

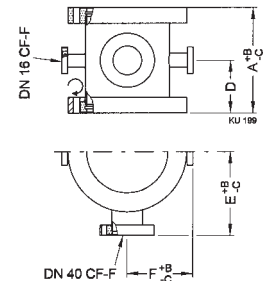

UHV CF Components

BELLOWS / HOSE WITH FLANGES, COMPENSATOR

Compensator

	DN...CF	Part No.	A	B	C	D	E	F	G
Flanges: Stainless steel 304/1.4301	40	213-346	120	10	0	36.8	100	10	10°
Bellows: Stainless steel 316Ti/1.4571	63	213-347	130	20	0	62	154	13	12°
	100	213-348	127	30	0	93	192	13	12°
Max. internal pressure for DN 40:									4 bar
Max. internal pressure for DN 63/100:									1.5 bar

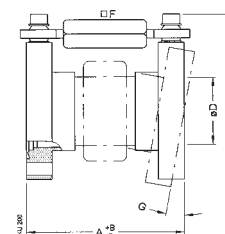

Bellows

	DN...CF	Part No.	A	B	C	D	E	F	G
Flanges: Stainless steel 304/1.4301	16	213-351	76	1.5	1.5	15	22	16	21°
Bellows: Stainless steel 316Ti/1.4571	40	213-352	126	2	2	40	55	36.8	7.5°
A = unstressed length	63	213-353	139	2	2	62	80	66	37°
Max. internal pressure DN 40:	100	213-354	142	2	2	92	116	102	28°
Max. internal pressure DN 63 ... 160:	160	213-355	250	3	3	154	187	153	16°

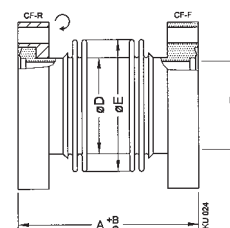

Flexible Metal

	DN...CF	Part No.	A	B	C	D	E	F	G
Flanges: Stainless steel 304/1.4301	16	213-361	250	23	16	15	22.5	70	50
Bellows: Stainless steel 316Ti/1.4571	16	213-362	500	23	16	15	22.5	70	50
	16	213-363	750	23	16	15	22.5	70	50
	16	213-364	1000	23	16	15	22.5	70	50
F = radius for multiple bending	40	213-365	250	46	36.8	40.5	53	130	100
G = radius for single bending	40	213-366	500	46	36.8	40.5	53	130	100
Max. internal pressure: 5 bar	40	213-368	1000	46	36.8	40.5	53	130	100

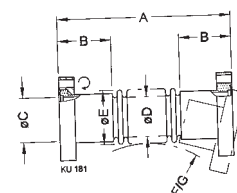

UHV CF Components

TRANSITION PIECES

Adapter CF-F/ISO-KF

	DN...CF-F	Part No.	A	B
Stainless steel 304/1.4301	16/16	213-251	35	16
	16/25	213-252	35	16
	40/16	213-254	30	16
	40/25	213-255	30	26
	40/40	213-256	50	37
	63/40	213-259	35	41
	100/40	213-262	50	41

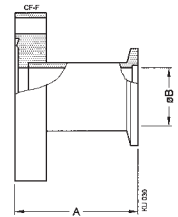

Adapter CF-F/ISO-K

	DN ... CF-F	Part No.	A	B	C	D
Stainless steel 304/1.4301	63/63	213-271	90	1	1	66
	100/100	213-272	90	1	1	104
	160/160	213-273	90	1.5	1.5	153

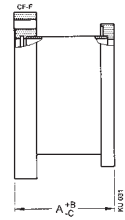

UHV CF Components

PROTECTIVE LIDS

Protective Lids	DN ... CF	Part No.	A	B	C
Polyethylene	16	213-441	36	34	9.5
	40	213-442	71.5	69.5	17.5
	63	213-443	115.5	113.5	22
	100	213-444	154	152	24.5
	160	213-445	205	202.5	27
	200	213-446	263	254	36
	250	213-447	315	306	36

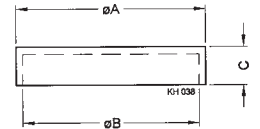



www.inficon.com reachus@inficon.com

Due to our continuing program of product improvements, specifications are subject to change without notice.

tiic85e1-c ©2009 INFICON