

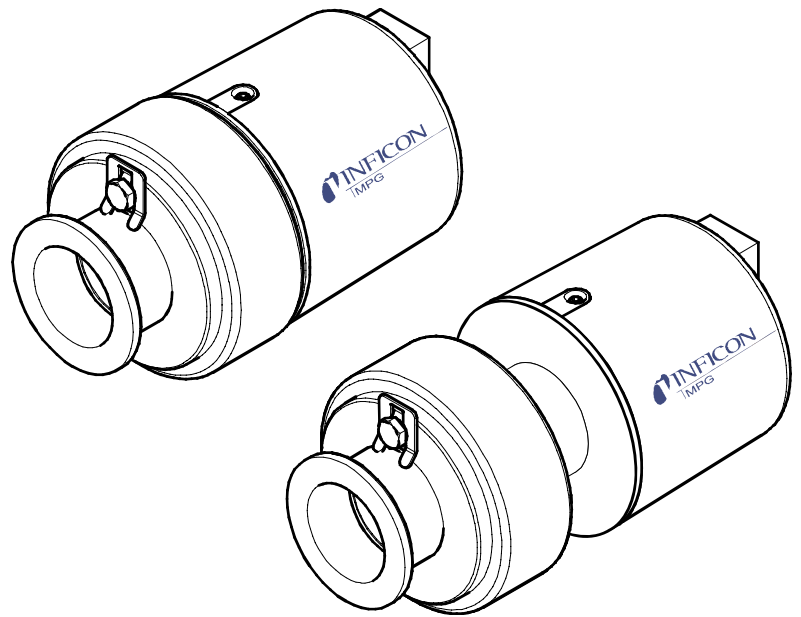

Inverted Magnetron Pirani Gauge

MPG400

MPG401



CE

Product Identification

In all communications with INFICON, please specify the information given on the product nameplate. For convenient reference copy that information into the space provided below:

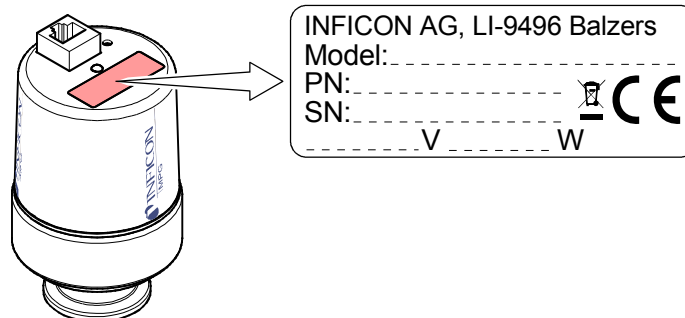

Validity

This document applies to products with part number:

MPG400 (FPM sealed)	MPG401 (all-metal)
351-010 (DN 25 ISO-KF)	351-020 (DN 25 ISO-KF)
351-011 (DN 40 ISO-KF)	351-021 (DN 40 ISO-KF)
351-012 (DN 40 CF-C)	351-022 (DN 40 CF-C)

The part number (PN) can be taken from the product nameplate.

If not indicated otherwise in the legends, the illustrations in this document correspond to the product with part number 351-010. They apply to the other products by analogy.

We reserve the right to make technical changes without prior notice.

All dimensions in mm.

Intended Use

The Inverted Magnetron Pirani Gauges MPG400 und MPG401 has been designed for vacuum measurement in the pressure range of 5×10^{-9} ... 1000 mbar.

The Inverted Magnetron Pirani Gauges must not be used for measuring flammable or combustible gases which react in air.

The gauges can be used with the Single-Channel Controller VGC401, the Two-Channel Controller VGC402 and the Three-Channel Controller VGC403 or with another evaluation unit.

Functional Principle

Over the whole measuring range, the measuring signal is output as a logarithm of the pressure.

The gauge consists of two separate measuring systems (the Pirani and the cold cathode system according to the inverted magnetron principle). They are combined in such a way that for the user, they behave like one measuring system

Contents

Product Identification	2
Validity	2
Intended Use	2
Functional Principle	2
1 Safety	4
1.1 Symbols Used	4
1.2 Personnel Qualifications	4
1.3 General Safety Instructions	4
1.4 Liability and Warranty	4
2 Technical Data	5
3 Installation	8
3.1 Vacuum Connection	8
3.1.1 Removing the Magnet Unit (Only for Gauges With CF Flanges)	10
3.2 Electrical Connection	11
3.2.1 Use With an INFICON Controller	11
3.2.2 Use With Another Control Device	11
4 Operation	12
4.1 Measurement Principle, Measuring Behavior	12
5 Deinstallation	14
6 Maintenance	15
6.1 Adjusting the Gauge	15
6.2 Cleaning MPG400, Replacing Parts	17
6.2.1 Disassembling MPG400	17
6.2.2 Cleaning MPG400	18
6.2.3 Reassembling MPG400	19
6.3 Cleaning MPG401, Replacing Parts	20
6.3.1 Disassembling MPG401	21
6.3.2 Cleaning MPG401	22
6.3.3 Reassembling MPG401	23
6.4 Troubleshooting	24
7 Accessories	25
8 Spare Parts	25
9 Returning the Product	27
10 Disposal	27
Appendix	28
A: Measuring Signal vs. Pressure	28
B: Gas Type Dependence	29
Declaration of Contamination	31

For cross-references within this document, the symbol (→  XY) is used.

1 Safety

1.1 Symbols Used



DANGER

Information on preventing any kind of physical injury.



WARNING

Information on preventing extensive equipment and environmental damage.



Caution

Information on correct handling or use. Disregard can lead to malfunctions or minor equipment damage.

1.2 Personnel Qualifications



Skilled personnel

All work described in this document may only be carried out by persons who have suitable technical training and the necessary experience or who have been instructed by the end-user of the product.

1.3 General Safety Instructions

- Adhere to the applicable regulations and take the necessary precautions for the process media used.
Consider possible reactions between the materials (→ 7) and the process media.
Consider possible reactions (e.g. explosion) of the process media due to the heat generated by the product.
- Adhere to the applicable regulations and take the necessary precautions for all work you are going to do and consider the safety instructions in this document.
- Before beginning to work, find out whether any vacuum components are contaminated. Adhere to the relevant regulations and take the necessary precautions when handling contaminated parts.

Communicate the safety instructions to all other users.

1.4 Liability and Warranty





INFICON assumes no liability and the warranty becomes null and void if the end-user or third parties

- disregard the information in this document
- use the product in a non-conforming manner
- make any kind of interventions (modifications, alterations etc.) on the product
- use the product with accessories not listed in the corresponding product documentation.

The end-user assumes the responsibility in conjunction with the process media used.

Gauge failures due to contamination, as well as expendable parts (filament), are not covered by the warranty.

2 Technical Data

Measuring range (air, N ₂)	5×10 ⁻⁹ ... 1000 mbar
Accuracy (N ₂)	≈±30% in the range 1×10 ⁻⁸ ... 100 mbar
Reproducibility	≈±5% in the range 1×10 ⁻⁸ ... 100 mbar
Gas type dependence	→ Appendix B
<hr/>	
Output signal (measuring signal)	
Voltage range	0 ... +10.5 V
Measuring range	1.82 ... 8.6 V
Voltage vs. pressure	logarithmic, 0.6 V / decade (→ Appendix)
Error signal	<0.5 V no supply >9.5 V Pirani measurement element defective (filament rupture)
<hr/>	
Output impedance	2×10 Ω
Minimum loaded impedance	10 kΩ, short-circuit proof
Response time (pressure dependent)	
p > 10 ⁻⁶ mbar	<10 ms
p = 10 ⁻⁸ mbar	≈1000 ms
<hr/>	
Gauge identification	85 kΩ referenced to supply common
<hr/>	
Status	Pin 6
p > 10 ⁻² mbar Pirani-only mode	 Low = 0 V
p < 10 ⁻² mbar Cold cathode not ignited Pirani-only mode	 Low = 0 V
p < 10 ⁻² mbar Cold cathode ignited Combined Pirani / cold cathode mode	 High = 15 ... 30 VDC
Lamp	High voltage on (LED on)
<hr/>	
Supply	
<div style="display: flex; align-items: center;">  <div style="background-color: red; color: white; padding: 5px; display: flex; align-items: center;">  DANGER </div> </div> <p>The gauge may only be connected to power supplies, instruments or control devices that conform to the requirements of a grounded extra-low voltage (SELV-E according to EN 61010). The connection to the gauge has to be fused¹⁾.</p>	
Supply voltage at the gauge	15.0 ... 30.0 VDC (ripple ≤ 1 V _{pp})
Power consumption	≤2 W
Fuse ¹⁾	≤1 AT
The minimum voltage of the power supply must be increased proportionally to the length of the sensor cable.	
Voltage at the supply unit with maximum line length	16.0 ... 30.0 VDC (ripple ≤ 1 V _{pp})
<hr/>	

¹⁾ INFICON controllers fulfill these requirements.

Adjustment	
<HV> potentiometer	at $<10^{-4}$ mbar
<ATM> potentiometer	at atmospheric pressure
Electrical connection	
Sensor cable	FCC68 female, 8 poles
Line length	8 conductors plus shielding
Operating voltage	
Operating current	≤ 3.3 kV
Grounding concept	
Vacuum connection-signal common	\rightarrow ("Electrical Connection") connected via 10 k Ω (max. voltage differential with respect to safety ± 50 V with respect to accuracy ± 10 V)
Supply common-signal common	conducted separately
Materials exposed to vacuum	
Vacuum connection	stainless steel
Measuring chamber	stainless steel
Feedthrough	ceramic
Internal seals	
MPG400	FPM 75
MPG401	Ag, Cu, soft solder (Sn, Ag)
Anode	Mo
Ignition aid	stainless steel
Pirani measuring tube	Ni, Au
Pirani filament	W
Mounting orientation	
Internal volume	≈ 20 cm ³
Pressure	≤ 10 bar (absolute) limited to inert gases
Temperatures	
Operation	
MPG400	+5 ... +55 °C
MPG401	+5 ... +150 °C (at flange in horizontal mounting orientation, without magnetic shielding)
Bakeout	+150 °C (without magnetic shielding and electronics unit)
Pirani filament	+120 °C
Storage	-40 °C ... +65 °C
Relative humidity	$\leq 80\%$ at temperatures up to +31 °C decreasing to 50% at +40 °C
Use	indoors only altitude up to 2000 m
Protection category	IP 40

Dimensions [mm]

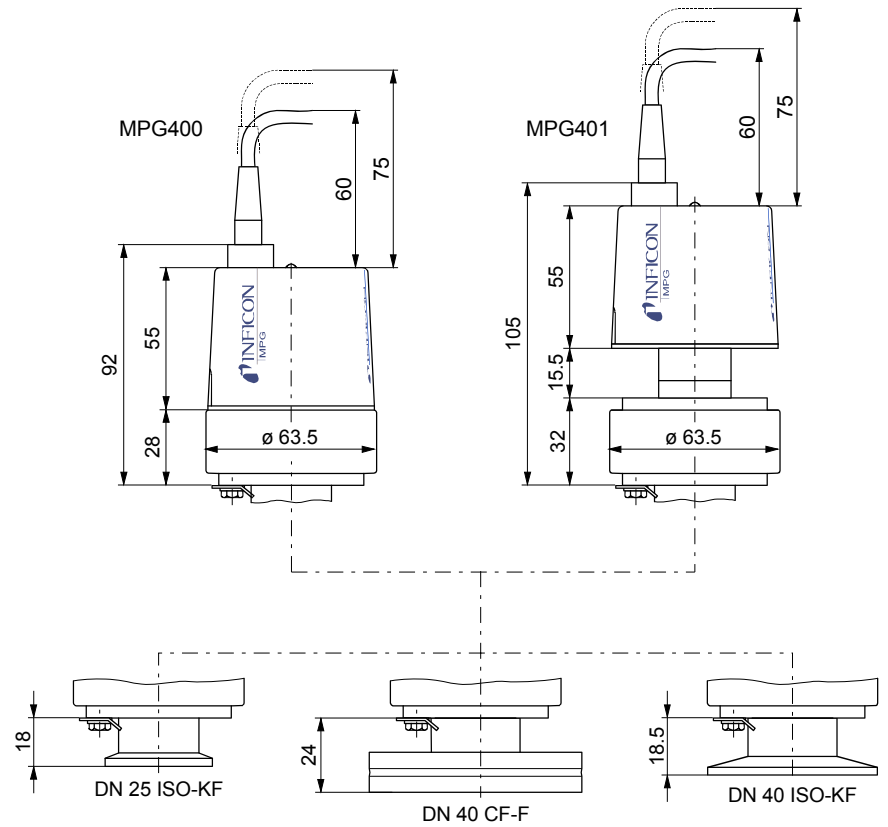

Weight

351-010	≈700 g	351-020	≈730 g
351-011	≈720 g	351-021	≈750 g
351-012	≈980 g	351-022	≈1010 g

3 Installation

3.1 Vacuum Connection



DANGER

DANGER: overpressure in the vacuum system >1 bar

Injury caused by released parts and harm caused by escaping process gases can result if clamps are opened while the vacuum system is pressurized.

Do not open any clamps while the vacuum system is pressurized. Use the type of clamps which are suited to overpressure.



DANGER

DANGER: overpressure in the vacuum system >2.5 bar

KF flange connections with elastomer seals (e.g. O-rings) cannot withstand such pressures. Process media can thus leak and possibly damage your health.

Use O-rings provided with an outer centering ring.



DANGER

DANGER: protective ground

Products that are not professionally connected to ground can be extremely hazardous in the event of a fault.

The gauge must be electrically connected to the grounded vacuum chamber. The connection must conform to the requirements of protective connection according to EN 61010:

- CF connections fulfill this requirement.
- For gauges with KF connections, use a conductive metallic clamping ring.



Caution

Caution: vacuum component

Dirt and damages impair the function of the vacuum component.

When handling vacuum components, take appropriate measures to ensure cleanliness and prevent damages.



Caution

Caution: dirt sensitive area

Touching the product or parts thereof with bare hands increases the desorption rate.

Always wear clean, lint-free gloves and use clean tools when working in this area.



The gauge may be mounted in any orientation. To keep condensates and particles from getting into the measuring chamber preferably choose a horizontal to upright position and possibly use a seal with a centering ring and filter.

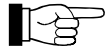

If adjustment should be possible after the gauge has been installed, be sure to install it so that the <HV> and <ATM> trimmer potentiometers can be accessed with a screw driver (→ 15).

Procedure

Remove the protective lid and install the product to the vacuum system.

When making a CF flange connection, it may be advantageous to temporarily remove the magnet unit (→ 10).

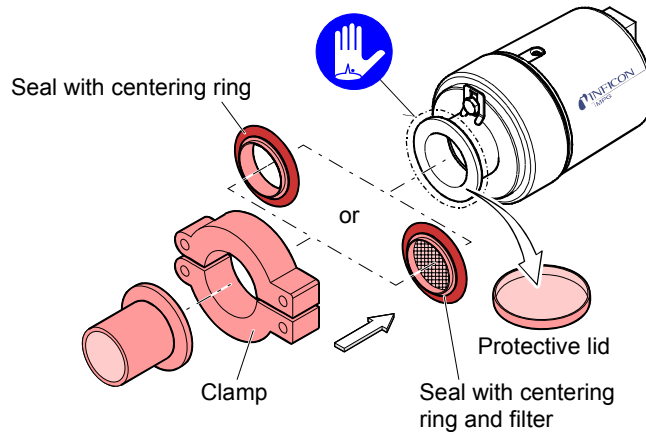

Keep the protective lid.

3.1.1 Removing the Magnet Unit (Only for Gauges With CF Flanges)

Tools required

- Allen wrench 1.5 mm
- Open-end wrench 7.0 mm

Procedure

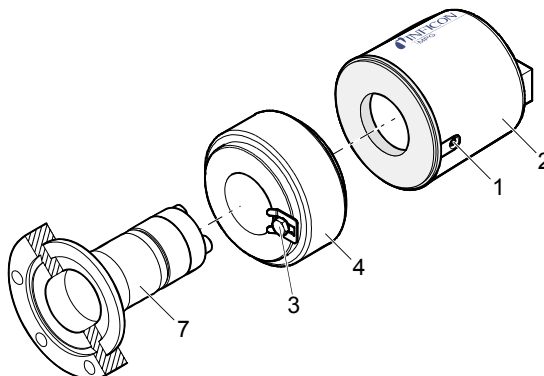

- Unfasten the hexagon socket set screw (1) on the electronics unit (2).
- Remove the electronics unit **without twisting it**.
- Unfasten the hexagon head screw (3) on the magnet unit (4) and remove the magnet unit.



The magnetic force and the tendency to tilt make it difficult to separate the magnet unit and the measuring chamber (7).

- Make the flange connection between the gauge and the vacuum system.
- Remount the magnet unit and lock it with the hexagon head screw (3).
- Carefully mount the electronics unit (2). (Make sure the pin of the Pirani element is properly plugged into the corresponding hole of the electronics unit.)
- Push the electronics unit up to the mechanical stop and lock it with the hexagon socket set screw (1).

3.2 Electrical Connection

Precondition

Make sure the vacuum connection is properly made (→ 8).

3.2.1 Use With an INFICON Controller

Connect the sensor cable to the gauge and the controller.

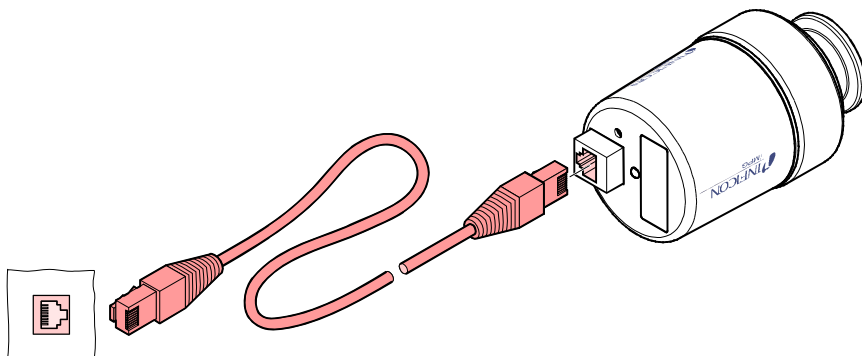

3.2.2 Use With Another Control Device

- 1 Make a sensor cable according to the diagram.

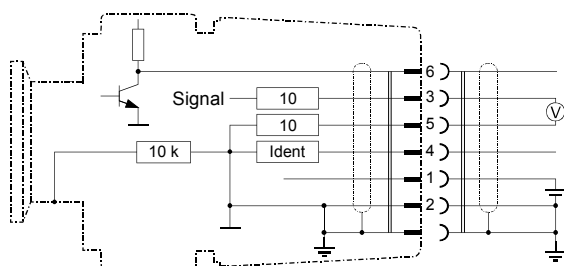

Electrical connection

Pin 1	Supply (15 ... 30 VDC)
Pin 2	Supply common
Pin 3	Signal output (Measuring signal)
Pin 4	Identification
Pin 5	Signal common
Pin 6	Status
Pin 7, 8	n.c.

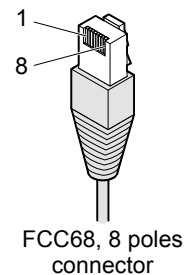

- 2 Connect the sensor cable to the gauge and the controller.

4 Operation

As soon as the required supply voltage is applied, the measuring signal is available between pins 3 and 5. (→ Appendix for the relationship between the measuring signal and the pressure).

Allow for a stabilizing time of approx. 10 min. Once the gauge has been switched on, permanently leave it on irrespective of the pressure.

4.1 Measurement Principle, Measuring Behavior

The gauge consists of two separate measuring systems (Pirani and cold cathode system according to the inverted magnetron principle). They are combined in such a way that for the user, they behave like one measuring system.

The optimum measuring configuration for the particular pressure range, in which measurement is performed, is used:

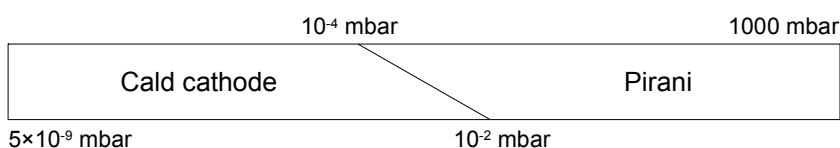

- The Pirani measuring circuit is always on
- The cold cathode measuring circuit is controlled by the Pirani circuit and is activated only at pressures $< 1 \times 10^{-2}$ mbar

The identification output (pin 6) indicates the current status of the gauge:

Pressure	Lamp on the gauge	Operating mode	Pin 6
$p > 1 \times 10^{-2}$ mbar		Pirani-only mode	Low = 0 V
$p < 1 \times 10^{-2}$ mbar		Cold cathode not ignited Pirani-only mode	Low = 0 V
$p < 1 \times 10^{-2}$ mbar		Cold cathode ignited Combined Pirani / cold cathode mode	High = 15 ... 30 VDC

As long as the cold cathode measuring circuit has not ignited, the measuring value of the Pirani is output as measuring signal (if $p < 5 \times 10^{-4}$ mbar, "Pirani underrange" is displayed).

Gas type dependence

The measuring signal depends on the type of gas being measured. The curves are accurate for dry air, O₂, CO and N₂. They can be mathematically converted for other gases (→ Appendix B).

If you are using an INFICON controller, you can enter a calibration factor to correct the pressure reading (→ of that controller).

Ignition delay

When cold cathode measuring systems are activated, an ignition delay occurs. The delay time increases at low pressures and is typically:

- 10⁻⁵ mbar ≈ 1 second
- 10⁻⁷ mbar ≈ 20 seconds
- 5 × 10⁻⁹ mbar ≈ 2 minutes

As long as the cold cathode measuring circuit has not yet ignited, the measured value of the Pirani is output as measuring signal ("Pirani underrange" is displayed for pressures $<5 \times 10^{-4}$ mbar). The identification output (pin 6, low) indicates the Pirani-only mode.



If the gauge is activated at a pressure $p < 3 \times 10^{-9}$, the gauge cannot recognize whether the cold cathode system has ignited. It indicates "Pirani underrange".



Once flanged on, permanently leave the gauge in the operating mode irrespective of the pressure range. Like this, the ignition delay of the cold cathode measuring circuit is always negligible (<1 s), and thermal stabilizing effects are minimized.

Contamination



Gauge failures due to contamination, as well as expendable parts (filament), are not covered by the warranty.

Gauge contamination is influenced by the process media used as well as by any present or new contaminants and their respective partial pressures. Continuous operation in the range of 10^{-4} mbar ... 10^{-2} mbar can cause severe contamination as well as reduced up-time and maintenance cycles. With constantly low pressures ($p < 1 \times 10^{-6}$ mbar), the gauge can be operated for more than one year without cleaning (cleaning the gauge → 17, 20).

Contamination of the gauge generally causes a deviation of the measured values:

- In the high pressure range (1×10^{-3} mbar ... 0.1 mbar), the pressure reading is too high (contamination of the Pirani element). Readjustment of the Pirani measuring system → 15.
- In the low pressure range ($p < 1 \times 10^{-3}$ mbar), the pressure reading is usually too low (contamination of the cold cathode system). In case of severe contamination, instabilities can occur (layers of the measuring chamber peel off). Contamination due to insulation layers can even lead to a complete failure of the discharge ("Underrange" is displayed).

Contamination can to a certain extent be reduced by:

- geometric protection measures (e.g. screenings, elbows) for particles that spread rectilinearly
- mounting the flange of the gauge at a place where the partial pressure of the pollutants is particularly low.

Special precautions are required for vapors deposited under plasma (of the cold cathode measuring system). It may even be necessary to temporarily switch of the gauge while such vapors occur.

5 Deinstallation

DANGER



DANGER: contaminated parts

Contaminated parts can be detrimental to health and environment. Before beginning to work, find out whether any parts are contaminated. Adhere to the relevant regulations and take the necessary precautions when handling contaminated parts.



Caution



Caution: vacuum component

Dirt and damages impair the function of the vacuum component. When handling vacuum components, take appropriate measures to ensure cleanliness and prevent damages.



Caution



Caution: dirt sensitive area

Touching the product or parts thereof with bare hands increases the desorption rate.

Always wear clean, lint-free gloves and use clean tools when working in this area.

Procedure

- 1** Vent the vacuum system.
- 2** Put the gauge out of operation and unplug the sensor cable.
- 3** Remove the gauge from the vacuum system and install the protective lid.



When deinstalling the CF flange connection, it may be advantageous to temporarily remove the magnet unit (→ 10).

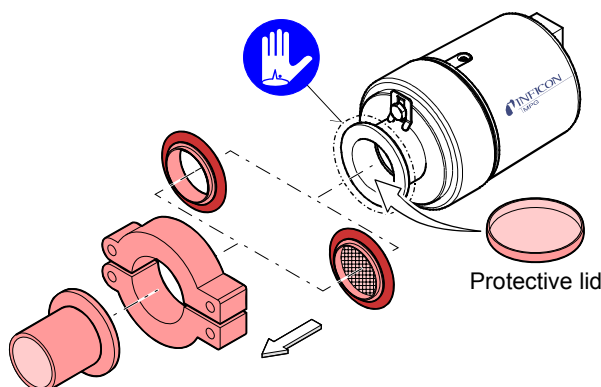

6 Maintenance



Gauge failures due to contamination, as well as expendable parts (filament), are not covered by the warranty.



DANGER



DANGER: contaminated parts

Contaminated parts can be detrimental to health and environment. Before beginning to work, find out whether any parts are contaminated. Adhere to the relevant regulations and take the necessary precautions when handling contaminated parts.



Caution



Caution: vacuum component

Dirt and damages impair the function of the vacuum component. When handling vacuum components, take appropriate measures to ensure cleanliness and prevent damages.



Caution



Caution: dirt sensitive area

Touching the product or parts thereof with bare hands increases the desorption rate. Always wear clean, lint-free gloves and use clean tools when working in this area.

6.1 Adjusting the Gauge

The gauge is factory-calibrated. If used under different climatic conditions, through extreme temperatures, aging or contamination, and after exchanging the sensor, the characteristic curve can be offset and readjustment may become necessary

The cold cathode measuring circuit, which is dominant for low pressures ($<1 \times 10^{-3}$ mbar), is factory-calibrated and cannot be adjusted. By way of contrast, the Pirani measuring circuit can be adjusted. Any adjustment has a negligible effect on the pressure range between approx. 10^{-2} mbar and 10^2 mbar.

Tools required

- Screw driver 1.5 mm
- Cylindrical pin $\varnothing \approx 3$ mm

Procedure

1

If you are using a seal with centering ring and filter, check that they are clean or replace them if necessary (→ 14).

2

Put the gauge into operation (if possible, in the position, in which it will be used later on).

3

Evacuate the vacuum system to $p \ll 10^{-4}$ mbar, and then wait 10 minutes.

4

Turn the nameplate counter-clockwise until the mechanical stop is reached.

5

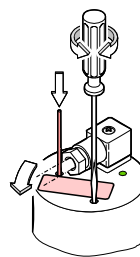

While depressing the pin with the cylindrical pin, adjust the <HV> potentiometer ...

... to 4.20 V

or

... to 5×10^{-4} mbar.

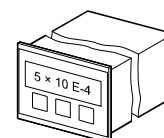
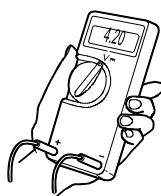

After that, turn the potentiometer counter-clockwise by 1/3 of a turn.

6

Vent the gauge with air or nitrogen to atmospheric pressure, and wait at least 10 minutes.

7

Turn the nameplate clockwise until the mechanical stop is reached.

8

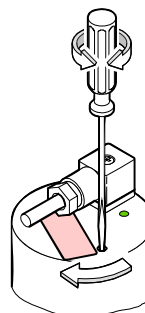

Using the 1.5 mm screwdriver, adjust the <ATM> potentiometer ...

... to 8.60 V

or

... to 1×10^3 mbar.

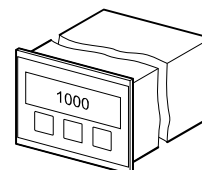
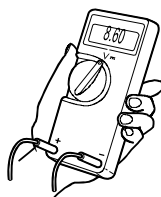

9

Turn the nameplate back to its original position (it catches).

6.2 Cleaning MPG400, Replacing Parts



STOP DANGER

DANGER: cleaning agents

Cleaning agents can be detrimental to health and environment. Adhere to the relevant regulations and take the necessary precautions when handling cleaning agents and disposing of them. Consider possible reactions with the product materials (→ 6).



We recommend replacing the Pirani element when cleaning the gauge.

Tools / material required

- Allen wrench AF 1.5
- Allen wrench AF 3
- Open-end wrench 7.0 mm
- Pliers for circlip
- Polishing cloth (400 grain) or Scotch-Brite
- Tweezers
- Cleaning alcohol
- Mounting tool for ignition aid
- Ignition aid
- Pirani element (13) incl. FPM seal (13a)
- FPM seal (11) for anode feedthrough

6.2.1 Disassembling MPG400

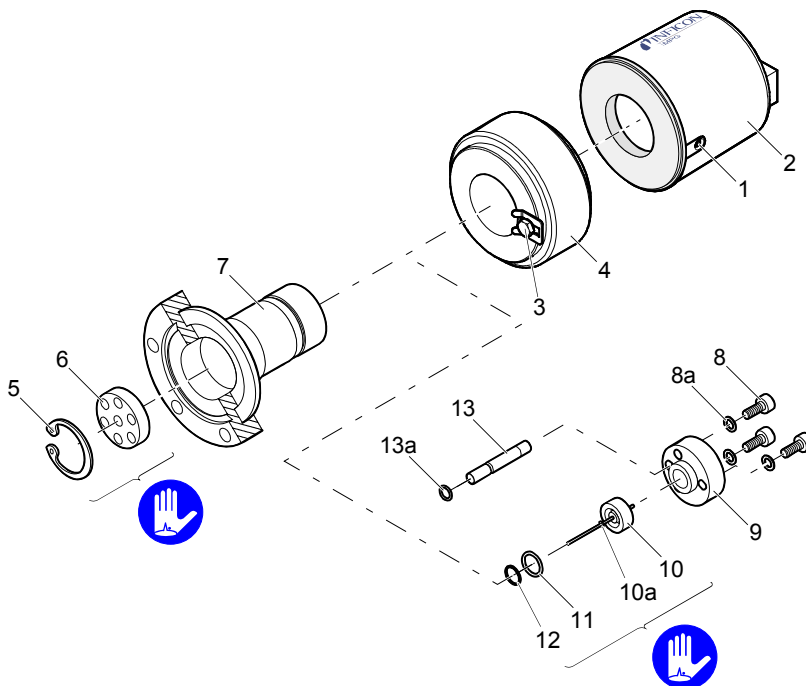

- ➊ Remove the gauge from the vacuum system (→ 14).
- ➋ Unfasten the hexagon socket set screw (1) on the electronics unit (2).
- ➌ Remove the electronics unit **without twisting it**.



The cover of the electronics unit cannot be removed.

- 4 Unfasten the hexagon head screw (3) on the magnet unit (4) and remove the magnet unit.



The magnetic force and the tendency to tilt make it difficult to separate the magnet unit and the measuring chamber (7).

- 5 Remove the circlip (5) and the polarity insert (6) from the measuring chamber

- 6 Remove the three hexagon socket screws (8) incl. lock washers (8a) on the back of the measuring chamber.

- 7 Carefully remove the following parts in this order (without exerting stress on the Pirani element (13)): pressure piece (9), complete anode (10), FPM seal (11) incl. support ring (12), Pirani element (13) incl. FPM seal (13a).

The parts can now be cleaned or replaced individually.

6.2.2 Cleaning MPG400

Cleaning the measuring chamber and the polarity insert

- 1 Using a polishing cloth rub the inside walls of the measuring chamber and the polarity insert to a bright finish.



The sealing surfaces must only be worked concentrically.

- 2 Rinse the measuring chamber and the polarity insert with cleaning alcohol.

- 3 Allow both to dry.

Cleaning or replacing the anode

- 1 Remove the used ignition aid (10a) with tweezers.

- 2 Using a polishing cloth rub the anode pin to a bright finish.



Do not bend the anode. Do not carry out mechanical work on the ceramic part.

- 3 Rinse the anode with cleaning alcohol.

- 4 Allow the anode to dry.

- 5 Insert a new ignition aid (10a) into the mounting tool.

- 6 Carefully press the anode (clean or new) centered and parallel to the tool axis into the ignition aid and insert it to a depth of approx. 15 mm. The final positioning is established after the anode is installed.

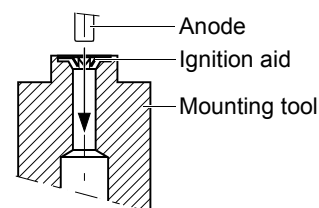

Cleaning the Pirani element

- 1 Remove the FPM seal (13a) from the Pirani element (13).
- 2 Fill the Pirani measuring tube with cleaning alcohol and let it work.
- 3 Pour the alcohol out of the tube.
- 4 Dry the tube (e.g. with a blow dryer <math><150\text{ }^\circ\text{C}</math>).
- 5 Slide a new FPM seal over the Pirani element and insert it into the corresponding groove.
- 6 Reinstall the Pirani element (→  19).

Replacing the Pirani element



If it is severely contaminated or defective.

- 1 Slide a new FPM seal (13a) over the Pirani element (13) and insert it into the corresponding groove.
- 2 Mount the Pirani element (→  19).

6.2.3 Reassembling MPG400

(→ figure  17)

- 1 Insert the FPM seal (11) with the support ring (12) centered into the measuring chamber (7). The sealing surface, seal, and ceramic part must be clean.
 - 2 Carefully insert the anode (10) incl. ignition aid (10a) into the measuring chamber.
 - 3 Insert the Pirani element (13) with the FPM seal (13a) slid over it into the corresponding bore hole.
 - 4 Carefully place the pressure piece (9) on the measuring chamber and tighten them with the three hexagon socket screws (8) incl. lock washers (8a) uniformly until the stop position is reached.
 - 5 Position the ignition aid (10a) by pushing the mounting tool over the anode pin until the mechanical stop is reached.
 - 6 Blow the particles in the measuring chamber with dry nitrogen (be careful to hold the measuring chamber with the flange pointing downwards).
 - 7 Slide the polarity insert (6) into the measuring chamber until the mechanical stop is reached.
 - 8 Place the circlip (5) snugly fitting on the polarity insert.
-  Visually check that the anode pin is centered over the middle hole of the polarity insert (max. eccentricity = 0.5 mm).
- 9 If possible perform a leak test (leak rate <math><10^{-9}</math> mbar l/s).

- 10 Mount the magnet unit (4) and lock it with the screw (3).
- 11 Carefully mount the electronics unit (2). (Make sure the pin of the Pirani element is properly plugged into the corresponding hole of the electronics unit.)
- 12 Push the electronics unit up to the mechanical stop and lock it with the hexagon socket set screw (1).
- 13 Adjust the gauge (→ 15).

6.3 Cleaning MPG401, Replacing Parts



DANGER

DANGER: cleaning agents

Cleaning agents can be detrimental to health and environment.

Adhere to the relevant regulations and take the necessary precautions when handling cleaning agents and disposing of them. Consider possible reactions with the product materials (→ 6).



For cleaning the measuring chamber, the Pirani element must be removed and replaced.

Tools / material required

- Allen wrench AF 1.5
- Allen wrench AF 3
- Open-end wrench AF 6
- Open-end wrench AF 7
- Pliers for circlip
- Polishing cloth (400 grain) or Scotch-Brite
- Tweezers
- Cleaning alcohol
- Mounting tool for ignition aid
- Ignition aid
- Metal seal (11) for anode feedthrough
- Pirani element (13) incl. set of seals (13a, 13b)

6.3.1 Disassembling MPG401

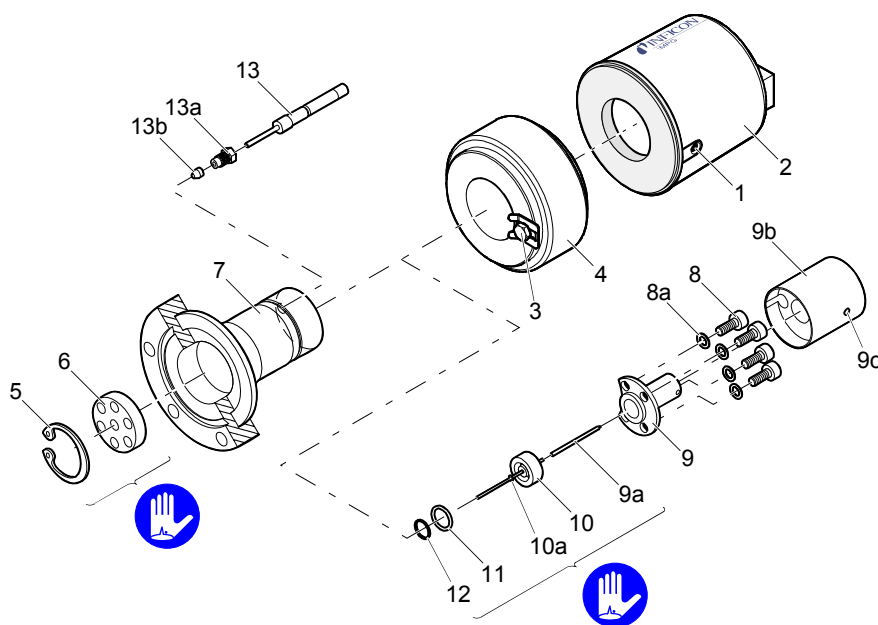

- ➊ Remove the gauge from the vacuum system (→ 14).
- ➋ Unfasten the hexagon socket set screw (1) on the electronics unit (2).
- ➌ Remove the electronics unit **without twisting it**.



The cover of the electronics unit cannot be removed.

- ➍ Unfasten the hexagon head screw (3) on the magnet unit (4) and remove the magnet unit.



The magnetic force and the tendency to tilt make it more difficult to separate the magnet unit and the measuring chamber (7).

- ➎ Remove the circlip (5) and the polarity insert (6) from the measuring chamber.
- ➏ Unfasten the hexagon socket set screw (9c) and remove the insulator (9b) **without twisting it**.
- ➐ Remove the four hexagon socket screws (8) incl. lock washers (8a) on the back of the measuring chamber.
- ➑ Carefully remove the following parts in this order (without exerting stress on the Pirani element (13)): pressure piece (9), anode extension piece (9a), complete anode (10), metal seal (11) incl. centering ring (12).
- ➒ Unfasten the screw fitting (13a) of the Pirani element and remove Pirani element together with the copper seal (13b).

The parts can now be cleaned or replaced individually.

6.3.2 Cleaning MPG401

Cleaning the measuring chamber and the polarity insert

- 1 Using a polishing cloth rub the inside walls of the measuring chamber and the polarity insert to a bright finish.



The sealing surfaces must only be worked concentrically.

- 2 Rinse the measuring chamber and the polarity insert with cleaning alcohol.
- 3 Allow both to dry.

Cleaning or replacing the anode

- 1 Remove the used ignition aid (10a) with pliers.

- 2 Using a polishing cloth rub the anode pin to a bright finish.



Do not bend the anode. Do not carry out mechanical work on the ceramic part.

- 3 Rinse the anode with cleaning alcohol.

- 4 Allow the anode to dry.

- 5 Insert a new ignition aid (10a) into the mounting tool.

- 6 Carefully press the anode (clean or new) centered and parallel to the tool axis into the ignition aid and insert it to a depth of approx. 15 mm. The final positioning is established after the anode is installed.

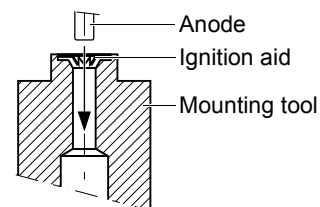

Replacing the Pirani element

- 1 Slide the screw fitting (13a) and the copper seal (13b) over the Pirani element (13).

- 2 Mount the Pirani element (→ 23).

6.3.3 Reassembling MPG401

(→ figure 21)

- 1 Insert the Pirani element (13) with the screw fitting (13a) and copper seal (13b) slid over it into the corresponding conic bore hole (7) of the measuring chamber.
 - 2 Tighten the screw fitting (13a) with your fingers while slightly pushing the Pirani element against the mechanical stop. Then tighten the screw fitting by one turn with the open-end wrench.
 - 3 Insert a new metal seal (11) incl. the centering ring (12) centered into the measuring chamber (7).
 - 4 Carefully insert the anode (10) with the ignition aid (10a) and extension piece (9a) slid onto it into the measuring chamber.
 - 5 Carefully place the pressure piece (9) on the measuring chamber.
 - 6 Insert the four hexagon socket screws (8) incl. lock washers (8a) and tighten them uniformly until the mechanical stop is reached.
 - 7 Carefully slide the insulator (9b) onto the pressure piece (9) and lock it with the hexagon socket set screw (9c).
 - 8 Position the ignition aid (10a) by pushing the mounting tool over the anode pin until the mechanical stop is reached.
 - 9 Blow the particles in the measuring chamber with dry nitrogen (be careful to hold the measuring chamber with the flange pointing downwards).
 - 10 Slide the polarity insert (6) into the measuring chamber until the mechanical stop is reached.
 - 11 Place the circlip (5) snugly fitting on the polarity insert.
-  Visually check that the anode pin is centered over the middle hole of the polarity insert (max. eccentricity = 0.5 mm).
- 12 If possible perform a leak test (leak rate $<10^{-9}$ mbar l/s). If necessary slightly retighten the screw fitting (13a).
 - 13 Mount the magnet unit (4) and lock it with the hexagon head screw (3).
 - 14 Carefully mount the electronics unit (2). (Make sure the pin of the Pirani element is properly plugged into the corresponding hole of the electronics unit.)
 - 15 Push the electronics unit up to the mechanical stop and lock it with the hexagon socket set screw (1).
 - 16 Adjust the gauge (→ 15).

6.4 Troubleshooting

Problem	Possible cause	Remedy
Measuring signal continually < 0.5 V "Error low".	No supply voltage.	Turn on the power supply.
Measuring signal continually > 9.5 V "Error high".	Pirani measurement element defective (filament rupture).	Replace the Pirani element (MPG400 → 19) (MPG401 → 22).
	Electronics unit not correctly mounted.	Mount the electronics unit correctly (MPG400 → 19) (MPG401 → 23).
The green lamp is ON and the identification indicates Pirani-only mode (measuring signal continually > 4.0 V) "Pirani underrange".	The cold cathode discharge has not ignited.	Wait until the gas discharge ignites (in case of contamination with insulation layers, the cold cathode may completely fail to ignite). (Cleaning MPG400 → 17 MPG401 → 20).
	The MPG has only been activated with $p < 3 \times 10^{-9}$ mbar.	Slightly increase the pressure.
Measuring signal continually > 5 V or display > 10^{-3} mbar although vacuum pressure is OK.	Pirani measurement circuit not adjusted, e.g. due to severe contamination.	Readjust the Pirani measurement circuit (→ 15). If adjustment is impossible, replace the Pirani element.
	Measurement of heavy gases.	Convert with the corresponding formula (→ 29).
	Severe outgassing in the cold cathode measuring chamber.	Clean the measuring chamber.
Measuring signal unstable.	Gauge contaminated.	Clean the gauge (MPG400 → 17) (MPG401 → 20).

7 Accessories

When ordering accessories, always mention:

- all information on the product nameplate
- description and ordering number according to the accessories list

Description	Ordering number
Magnetic shielding	BG443155-X

8 Spare Parts

When ordering spare parts, always mention:

- all information on the product nameplate
- description and ordering number according to the spare parts list

MPG400

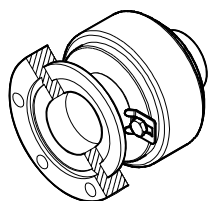
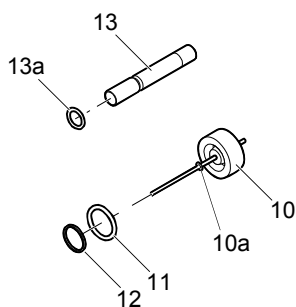

Pos.	Description	Ordering number
	Maintenance kit, consisting of:	351-999
12	1× support ring	
13a	1× O-ring FPM $\varnothing 3.69 \times 1.78$	
11	1× O-ring FPM $\varnothing 10.82 \times 1.78$	
10a	3× ignition aid	
	Repair kit, consisting of:	351-998
13	1× Pirani element	
12	1× support ring	
13a	1× O-ring FPM $\varnothing 3.69 \times 1.78$	
11	1× O-ring FPM $\varnothing 10.82 \times 1.78$	
10a	3× ignition aid	
10	1× anode, complete	
	Set of ignition aids, comprising:	351-995
10a	10× ignition aid	
	Mounting tool for ignition aid	351-994
	Measuring system	
	DN 25 ISO-KF flange	BN846469-T
	DN 40 ISO-KF flange	BN846470-T
	DN 40 CF-F flange	BN846471-T

MPG401

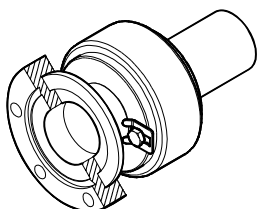
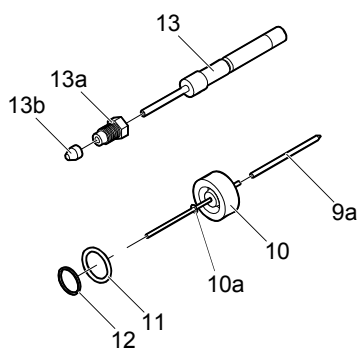

Pos.	Description	Ordering number
	Maintenance set, consisting of:	351-997
11	1× seal HNV 100 (9×1.6)	
12	1× centering ring	
10a	3× ignition aid 1× washer (not used with MPG401)	
	Repair set, consisting of:	351-996
13	1× Pirani element with glass feedthrough	
13a	1× screw fitting	
13b	1× copper seal	
9a	1× anode extension piece	
10	1× anode, complete	
10a	3× ignition aid	
11	1× seal HNV 100 (9×1.6)	
12	1× centering ring	
10a	Set of ignition aids, consisting of: 10× ignition aid	351-995
	Mounting tool for ignition aid	351-994
	Measurement system, complete	
	DN 25 ISO-KF flange	BN846472-T
	DN 40 ISO-KF flange	BN846473-T
	DN 40 CF-F flange	BN846474-T

9 Returning the Product

WARNING

WARNING: forwarding contaminated products
 Contaminated products (e.g. radioactive, toxic, caustic or biological hazard) can be detrimental to health and environment.
 Products returned to INFICON should preferably be free of harmful substances. Adhere to the forwarding regulations of all involved countries and forwarding companies and enclose a duly completed declaration of contamination (→ 31).

Products that are not clearly declared as "free of harmful substances" are decontaminated at the expense of the customer.

Products not accompanied by a duly completed declaration of contamination are returned to the sender at his own expense.

10 Disposal

DANGER

DANGER: contaminated parts
 Contaminated parts can be detrimental to health and environment.
 Before beginning to work, find out whether any parts are contaminated. Adhere to the relevant regulations and take the necessary precautions when handling contaminated parts.

WARNING

WARNING: substances detrimental to the environment
 Products or parts thereof (mechanical and electric components, operating fluids etc.) can be detrimental to the environment.
 Dispose of such substances in accordance with the relevant local regulations.

Separating the components

After disassembling the product, separate its components according to the following criteria:

Contaminated components

Contaminated components (radioactive, toxic, caustic or biological hazard etc.) must be decontaminated in accordance with the relevant national regulations, separated according to their materials, and disposed of.

Other components

Such components must be separated according to their materials and recycled.

Appendix

A: Measuring Signal vs. Pressure

Conversion formulae

$$p = 10^{1.667U-d} \Leftrightarrow U = c + 0.6 \log_{10} p$$

p	U	c	d
[mbar]	[V]	6.8	11.33
[Torr]	[V]	6.875	11.46
[Pa]	[V]	5.6	9.333

where p pressure valid in the range 5×10^{-9} mbar < p < 1000 mbar
 U measuring signal 3.8×10^{-9} Torr < p < 750 Torr
 c, d constant (pressure unit dependent) 5×10^{-7} Pa < p < 1×10^5 pa

Conversion curves

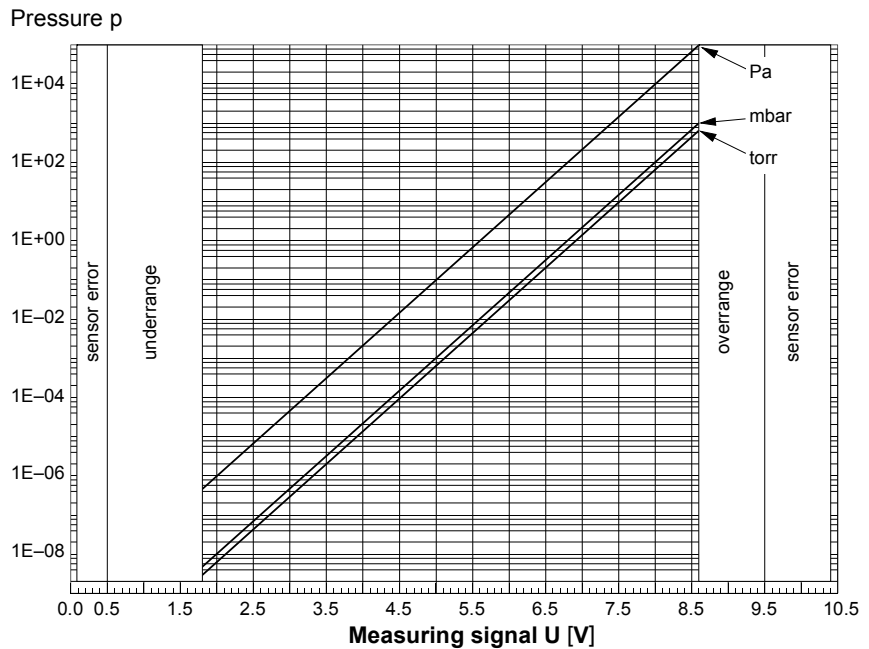

Conversion table

Meas. signal U [V]	Pressure p [mbar]	Pressure p [Torr]	Pressure p [Pa]
<0.5	Sensor error		
0.5 ... 1.82	Underrange		
1.82	5.0×10^{-9}	3.8×10^{-9}	5.0×10^{-7}
2.0	1.0×10^{-8}	7.5×10^{-9}	1.0×10^{-6}
2.6	1.0×10^{-7}	7.5×10^{-8}	1.0×10^{-5}
3.2	1.0×10^{-6}	7.5×10^{-7}	1.0×10^{-4}
3.8	1.0×10^{-5}	7.5×10^{-6}	1.0×10^{-3}
4.4	1.0×10^{-4}	7.5×10^{-5}	1.0×10^{-2}
5.0	1.0×10^{-3}	7.5×10^{-4}	0.1
5.6	1.0×10^{-2}	7.5×10^{-3}	1.0
6.2	0.1	7.5×10^{-4}	10
6.8	1.0	0.75	100
7.4	10	7.5	1000
8.0	100	75	1.0×10^4
8.6	1000	750	1.0×10^5
8.6 ... 9.5	Overrange		
9.5 ... 10.5	Sensor error (Pirani defective)		

B: Gas Type Dependence

Indication range above
 10^{-2} mbar

Pressure indicated (gauge calibrated for air).

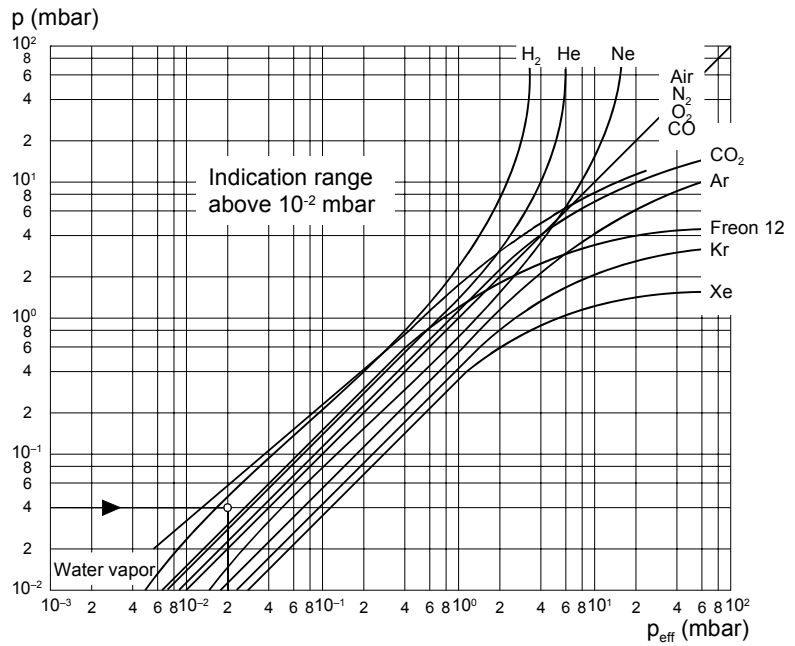

Indication range
 10^{-6} ... 0.1 mbar

Pressure indicated (gauge calibrated for air).

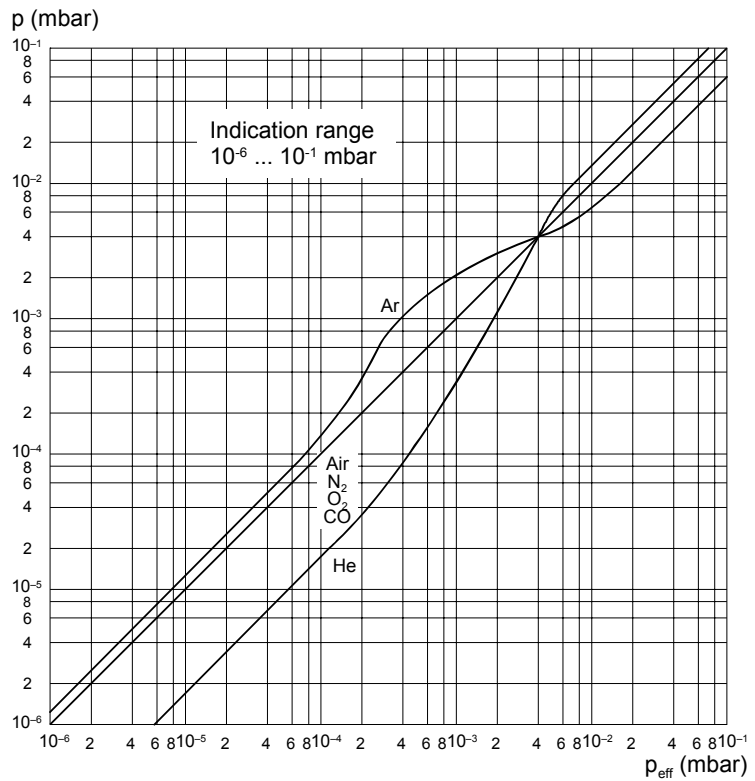

Indication range below
 10^{-5} mbar

In the range below 10^{-5} mbar, the pressure indication is linear. For gases other than air, the pressure can be determined by means of a simple conversion formula:

$$p_{\text{eff}} = K \times \text{pressure indicated}$$

where	gas type	K
	air (O ₂ , CO, N ₂)	1.0
	Xe	0.4
	Kr	0.5
	Ar	0.8
	H ₂	2.4
	Ne	4.1
	He	5.9

These conversion factors are average values.



A mixture of gases and vapors is often involved. In this case, accurate determination is only possible with a partial pressure measurement instrument, e.g. a quadrupole mass spectrometer.

Declaration of Contamination

The service, repair, and/or disposal of vacuum equipment and components will only be carried out if a correctly completed declaration has been submitted. Non-completion will result in delay.

This declaration may only be completed (in block letters) and signed by authorized and qualified staff.

1 Description of product
 Type _____
 Part number _____
 Serial number _____

2 Reason for return

3 Operating fluid(s) used (Must be drained before shipping.)

4 Used in copper process
 no yes **Seal product in plastic bag and mark it with a corresponding label.**

5 Process related contamination of product:

toxic	no <input type="checkbox"/>	1)	yes <input type="checkbox"/>
caustic	no <input type="checkbox"/>	1)	yes <input type="checkbox"/>
biological hazard	no <input type="checkbox"/>		yes <input type="checkbox"/> 2)
explosive	no <input type="checkbox"/>		yes <input type="checkbox"/> 2)
radioactive	no <input type="checkbox"/>		yes <input type="checkbox"/> 2)
other harmful substances	no <input type="checkbox"/>	1)	yes <input type="checkbox"/>

2) Products thus contaminated will not be accepted without written evidence of decontamination.

The product is free of any substances which are damaging to health. yes

1) or not containing any amount of hazardous residues that exceed the permissible exposure limits

6 Harmful substances, gases and/or by-products
 Please list all substances, gases, and by-products which the product may have come into contact with:

Trade/product name	Chemical name (or symbol)	Precautions associated with substance	Action if human contact

7 Legally binding declaration:
 We hereby declare that the information on this form is complete and accurate and that we will assume any further costs that may arise. The contaminated product will be dispatched in accordance with the applicable regulations.

Organization/company _____

Address _____ Post code, place _____

Phone _____ Fax _____

Email _____

Name _____

Date and legally binding signature _____ Company stamp _____

This form can be downloaded from our website.

Copies: Original for addressee - 1 copy for accompanying documents - 1 copy for file of sender

Original: German tina48d1-a (2006-12)



tina48e1-a



LI-9496 Balzers
Liechtenstein
Tel +423 / 388 3111
Fax +423 / 388 3700
reachus@inficon.com

www.inficon.com