



INSTRUCTION MANUAL
SAFE 2010 & Maxi SAFE 2010
ID 807233

Important user information

Please read this entire manual to fully understand the safe and effective use of this product.



In case you have any comments about this manual we will appreciate receiving them at the address below.

Warranty and Liability

Jouan Nordic A/S guarantees that the product delivered has been thoroughly tested to ensure that it meets its published specifications. The warranty included in the conditions of delivery is valid only if the product has been installed and used in accordance with the instructions supplied by Jouan Nordic A/S.

Jouan Nordic A/S shall in no event be liable for incidental or consequential damages, including without limitation, lost profits, loss of income, loss of business opportunities, loss of use, and other related exposures, caused by e.g. incorrect use of the product.

Symbols used in this manual

	WARNING Used in case of danger of a serious accident or when documentation needs to be consulted.
	NOTE Used to direct attention to a special item.

© Copyright 2003

Jouan Nordic A/S
Gydevang 17-19
DK-3450 Allerød
Denmark

Telephone +45 48 16 62 00
Fax +45 48 16 62 97
e-mail info.dk@thermo.com

Home page: <http://www.jouannordic.com>

Table of contents

1.	Introduction	4
2.	Safety precautions	4
3.	Description.....	5
3.1.	Working principle	5
3.2.	Air filtration	5
3.3.	Air velocity monitoring	5
3.4.	Airflow diagram.....	6
3.5.	Design	6
4.	EN 12469 approvals.....	8
5.	Technical specifications	9
5.1.	Property of materials	11
6.	Installation	12
6.1.	Transport through passage narrower than 900 mm	12
6.2.	Preparation.....	13
6.3.	Connections	14
7.	Testing	14
7.1.	Air velocity in laminar flow	15
7.2.	Air velocity in inlet and exhaust opening	15
7.3.	Airflow patterns, visualisation	16
7.4.	Test of filters.....	16
7.5.	Test of the retention at front opening	17
8.	Work rules.....	17
8.1.	Before start-up.....	17
8.2.	While working	18
8.3.	After work	18
9.	Control Panel	19
9.1.	Control Panel.....	19
9.2.	LCD Display	20
9.3.	Bar graph	21
9.4.	Operation	21
9.5.	Supervision - Alarm	22
10.	Cleaning and decontamination.....	23
10.1.	Daily	23
10.2.	Weekly	24
10.3.	Regularly	24
10.4.	Decontamination by use of formaldehyde	24
11.	Maintenance.....	26
11.1.	Filters	26
11.1.1.	Main and exhaust filter exchange	26
11.1.2.	Procedure for replacement of main filter	27
11.1.3.	Procedure for replacement of exhaust filter	28
11.1.4.	Pre-filter (MaxiSAFE Only)	29
11.2.	Part list for filter	29
11.3.	Activated charcoal filters (Optional equipment).....	30
11.4.	Fuses	31
11.5.	Fluorescent light tube	32
11.6.	Starter	33
11.7.	Electrical spare parts	33
12.	Logbook	34
13.	Statement.....	35

Enclosure: Declaration of conformity

1. Introduction

You are now in possession of a high quality microprocessor-controlled Class II cabinet, Holten SAFE 2010/MaxiSAFE 2010, designed to provide protection of the operator, the environment, and the processed product against particle-/microbiological contamination.

The cabinet complies with the requirements stipulated in EN 12469 for SAFE 2010 and DIN 12980 for MaxiSAFE 2010. In chapter 4 you can see the options and sizes of approved cabinets.

- The Holten SAFE 2010/MaxiSAFE 2010 Class II cabinet is/has:
- Microprocessor controller with.
 - LCD display indicating fan and alarm status.
 - Air velocity (filter service) indicator.
 - Clock (7 days) and hour-counter.
 - Pre-setting of automatic start-up and UV-timer.
 - Alarm for any deviation from safety conditions.
- Ergonomically correct sloping front for maximum operator comfort.
- Motor-driven, double-function front window, with both sliding and hinged modes.
- Side windows, for perfect light conditions and view to the surroundings.
- Negative pressure plenum for highest operator and product safety.
- Key switch to prevent unauthorised starting and stopping of the fan.
- Adjustable FAN speeds. Gives you the opportunity to select FAN off, reduced, or normal air velocity.

2. Safety precautions

- To avoid unintended or improper operation of the cabinet, please carefully read this manual.
- Also, please pay attention to the short form operating instructions on the label stuck on the cabinet.
- If you have questions related to the function or control of the cabinet or wish to order spare parts, please always indicate type and production number from the nameplate on the right side of the cabinet.

**WARNING**

The proper function and safety of the cabinet are only secured if personnel authorised by us to do so perform the required tests, maintenance and repair work.

Please also refer to sections "Testing" and "Maintenance".

The following precautions must be taken for operation of the Holten SAFE 2010/MaxiSAFE 2010.

**WARNING**

The safety cabinet must not be used for Group 4 pathogens.

Attention is drawn to the risk assessment requirements of the Control of Substances Hazardous to Health (COSHH) Regulations 1999. (UK).

**WARNING**

The cabinet is not suitable for HIGH-RISK biological agents.

HIGH RISK biological agents include all etiologic agents designated Class 4 by CDC, and oncogenic viruses classed high risk by NCI. (USA).

**WARNING**

Never operate the Holten SAFE 2010/MaxiSAFE 2010 cabinet if the fan compartment cover is removed.

If this cover is removed, the cabinet will give no protection of the operator or the environment and the fan will run with openly rotating blades.

**WARNING**

The Holten SAFE 2010/MaxiSAFE 2010 Class II cabinet will not provide any protection for operator or environment against harmful gases or vapours.

**WARNING**

Always keep your hands out of the work chamber before starting the sliding window.

The airspeed monitoring system needs approximately 5 minutes to warm up and stabilise after the fan has been switched on.

3. Description

3.1. Working principle

The microbiologic safety cabinet is a modified exhaust cabinet with a turbulence-free (laminar) vertical displacement flow of clean air in the work chamber protecting the product against particle contamination. During operation the front window is partly open and the in-going airflow prevents the escape of particles from the inside of the work chamber thus protecting the operator and the environment.

3.2. Air filtration

The MaxiSAFE 2010 pre-filter and the main filter and exhaust filter of SAFE 2010/MaxiSAFE 2010 are all high-efficiency HEPA filters.

3.3. Air velocity monitoring

The low turbulence vertical flow and the exhaust flow are monitored by means of air velocity sensors. Any deviation from safe conditions will be indicated optically and acoustically.

3.4. Airflow diagram

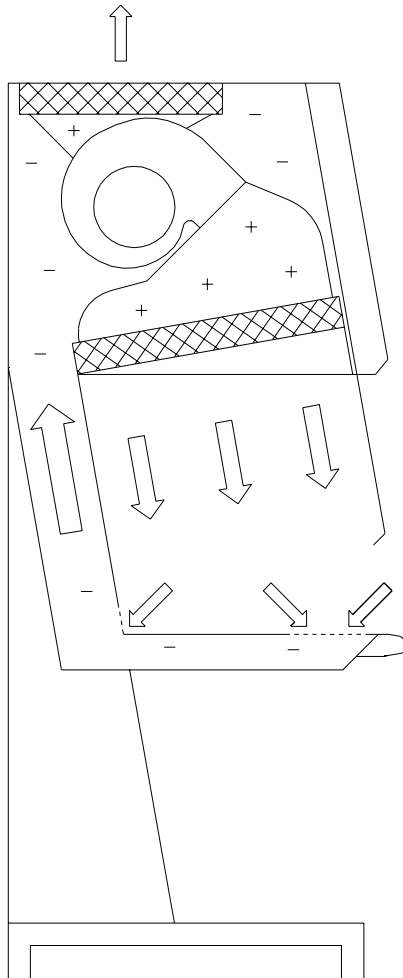

Figure Fejl! Ukendt argument for parameter..
SAFE 2010

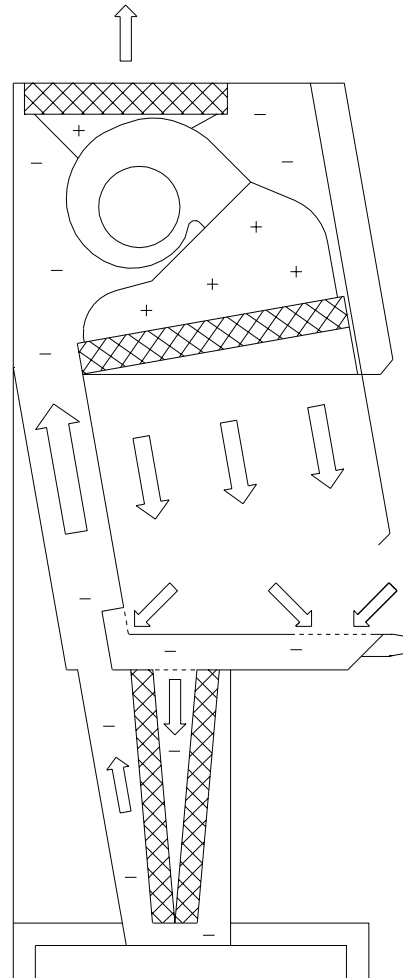

Figure Fejl! Ukendt argument for parameter..
MaxiSAFE 2010

3.5. Design

The safety cabinet consists of:

- Fan and filter compartment and return air duct (double back wall) made of polyester coated sheet steel.
- Support stand made of polyester coated sheet steel and equipped with levelling feet.
- Work chamber with tabletop and trough in stainless steel (AISI 304).
- Side windows and sliding front window all in safety glass.
- Internal ventilation system with negative pressure plenum.
- Microprocessor control and supervision system.

The work chamber is formed by the ceiling (main HEPA filter), side windows, back wall with installation zones, tabletop and trough; the front is partly closed by the double-action, sliding front window; the work opening is situated below the front window.

- The outlet opening of the main HEPA filter cover the entire ceiling surface thus giving an extremely uniform airflow.

- The trough will collect and hold any spillage of fluids. A drain valve can be installed (Standard on MaxiSAFE 2010).
- The installation zones in the back wall can be equipped with electric outlets and a UV-light fixture.
- The side windows come with holes for installation of valves.
- The stainless steel modular tabletop is easily removed for cleaning.
- The internal light is installed on the front of the work chamber outside the front window. This secures that the light is glare-free and will cause neither turbulence nor unwanted heating inside the work chamber.
- Arm rest for air intake efficiency.

Options:

- UV light integrated in the back wall behind a small door.
- Protective ground sockets 230V ~ / 4A installed in the back wall.
- Valves for various gasses i.e. gas, nitrogen (N₂) vacuum, or Carbon dioxide (CO₂), a maximum of 3 installed in each side window.
- Exhaust valve for connection to the exhaust system – consult your dealer for detailed information.
- Double HEPA-filter exhaust system as specified by BS 5726-(92).

Please contact our sales department for information regarding other available options.

4. EN 12469 approvals

The SAFE and MaxiSAFE 2010 1.2, 1.5 and 1.5 are approved in different configurations.

The table shows the type and the options:

Approved options for Microbiological Safety cabinets
Maximum 2 electrical outlets in each side
Maximum 3 gas valves in each side window
Alternative filter Camfil H14
UV light
Battery back-up
Multiple processing relay
Cabinet without support stands (Table model) Only SAFE
Support stand table model
Elevation stand table height 70 – 100 cm
Support stand low 76 - 80 cm ± 2 cm
Support stand high 88 - 92 cm ± 2 cm
Single module table top
2 module table top in the centre Only SAFE / MaxiSAFE 1.2 and 1.8
3 module tabletop in the centre Only SAFE / MaxiSAFE 1.5
4 module tabletop in the centre Only SAFE / MaxiSAFE 1.2 and 1.8
5 module tabletop Only SAFE / MaxiSAFE 1.5
Stainless steel back wall / sides
Weighting top of marble
Drain valve Standard on MaxiSAFE
Magnetic valve
Foot contact

5. Technical specifications

All parts of the cabinet which has a negative pressure is tested in accordance with EN 12469:2000 Annex B, and meet the LI-C level.

Model 0.9	SAFE	MaxiSAFE
External dimensions, DxWxH mm	895x1040x2000	
Chamber dimensions, DxWxH mm	580x900x725/650	
Weight, kg	200	225
Spillage, litres	13.5	4.5
Exhaust volume, m ³ /h ± 10 %	300	
Air velocity in-flow, m/s	≥ 0.4	
Air velocity down-flow, m/s ± 20 %	0.4	
Noise level, DIN dB(A); EN ISO 3744	55	57
Light intensity, Lux	>1200	
Supply Voltage/frequency, Volts/Hz	230/50	
Power consumption, Watts	500	
Required fusing	Fuse T16A or circuit breaker 16A	
Input current, A	1.6	
 Socket outlet(s), Volts/Hz/Amps	230/50/4	
Maximum leakage current, mA	0.7	

Model 1.2	SAFE	MaxiSAFE
External dimensions, DxWxH mm	895x1340x2000	
Chamber dimensions, DxWxH mm	580x1200x725/650	
Weight, kg	225	250
Spillage, litres	18	6
Exhaust volume, m ³ /h ± 10 %	400	
Air velocity in-flow, m/s	≥ 0.4	
Air velocity down-flow, m/s ± 20 %	0.4	
Noise level, DIN dB(A); EN ISO 3744	57	59
Light intensity, Lux	>1200	
Supply Voltage/frequency, Volts/Hz	230/50	
Power consumption, Watts	600	
Required fusing	Fuse T16A or circuit breaker 16A	
Input current, A	1.8	
 Socket outlet(s), Volts/Hz/Amps	230/50/4	
Maximum leakage current, mA	0.7	

Model 1.5	SAFE	MaxiSAFE
External dimensions, DxWxH mm	895x1640x2000	
Chamber dimensions, DxWxH mm	580x1500x725/650	
Weight, kg	270	315
Spillage, litres	22.5	7.5
Exhaust volume, m ³ /h ± 10 %	500	
Air velocity in-flow, m/s	≥ 0.4	
Air velocity down-flow, m/s ± 20 %	0.4	
Noise level, DIN dB(A); EN ISO 3744	58	59
Light intensity, Lux	>1200	
Supply Voltage/frequency, Volts/Hz	230/50	
Power consumption, Watts	700	
Required fusing	Fuse T16A or circuit breaker 16A	
Input current, A	2.6	
 Socket outlet(s), Volts/Hz/Amps	230/50/4	
Maximum leakage current, mA	0.7	

Model 1.8	SAFE	MaxiSAFE
External dimensions, DxWxH mm	895x1940x2000	
Chamber dimensions, DxWxH mm	580x1800x725/650	
Weight, kg	300	355
Spillage, litres	27	9
Exhaust volume, m ³ /h ± 10 %	600	
Air velocity in-flow, m/s	≥ 0.4	
Air velocity down-flow, m/s ± 20 %	0.4	
Noise level, DIN dB(A); EN ISO 3744	58	59
Light intensity, Lux	>1200	
Supply Voltage/frequency, Volts/Hz	230/50	
Power consumption, Watts	800	
Required fusing	Fuse T16A or circuit breaker 16A	
Input current, A	3.0	
 Socket outlet(s), Volts/Hz/Amps	230/50/4	
Maximum leakage current, mA	0.7	

5.1. Property of materials

Units	Material	Treatment
Front and side windows	Safety glass	Laminated/tempered
Front window frame	Stainless steel AISI 304	Polished
Side window frame	PVC	
Support stand	Steel 1203 2 mm	Polyester-coated RAL 7038
Front shield	Al Mg 3, 2 mm	Polyester-coated RAL 7038
All other painted parts	Steel 1203, 1.5 mm	Polyester-coated RAL 9002
Trough and tabletop	Stainless steel AISI 304	Polished
Internal main and exhaust plenum	Polystyrene	

6. Installation

Transport of the SAFE 2010/MaxiSAFE 2010 can be carried out by lifting the cabinet using a forklift either sideways under the support stand or directly under the trough. Furthermore the cabinet can be moved manually by using hooks in the dedicated holes in the support stand.



WARNING

Whenever transportation of the cabinet is needed, precautions should be taken to prevent it from overturning due to the high-located mass centre.



WARNING

In order to prevent damage to the cabinet it must be handled as fragile goods.

Storage of the cabinet must be in an environment of maximum 80 % relative humidity and at temperatures between 5 °C to 50 °C.

6.1. Transport through passage narrower than 900 mm.

The cabinet may be tilted 10 °, see figure 3 so that the sloping front is in vertical position. If the passage is narrower than 850 mm you may dismount the front shield with the control panel and the bracket holding the mains plug on the back of the cabinet, see figure 4.

The cabinet can then be moved through a standard 800 mm wide door.

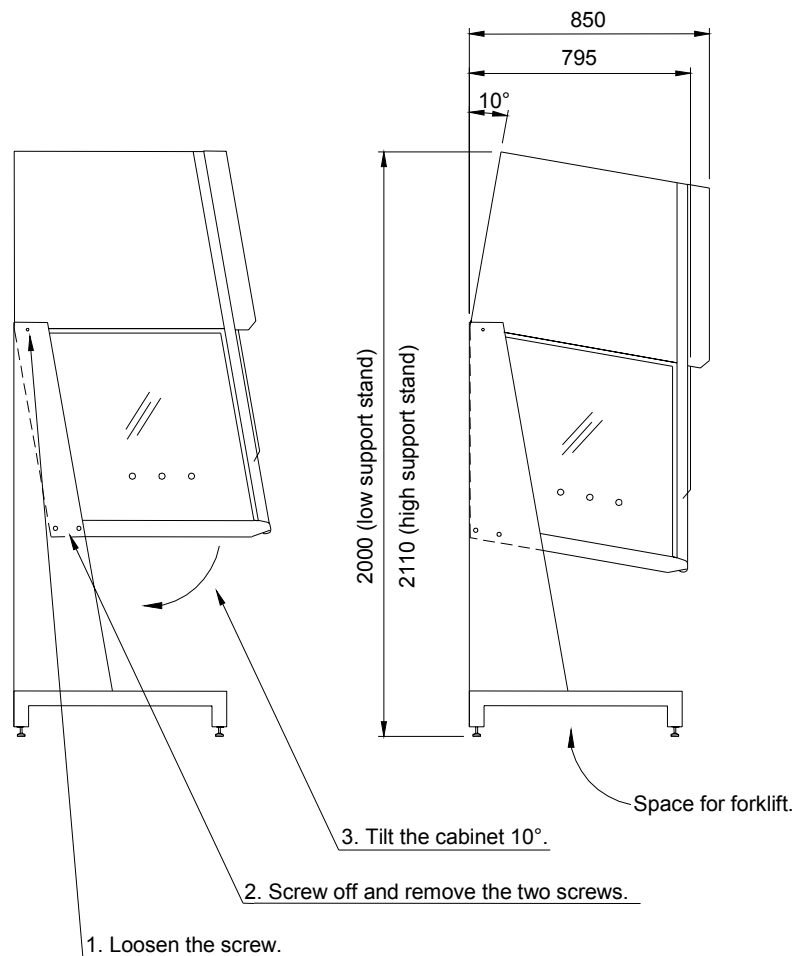

Figure Fejl! Ukendt argument for parameter.. How to tilt the cabinet.

1. Bring the front window to the lowest position.
2. Disconnect the power.
3. Remove the protective cover from the fuses (4 screws) - position 1 figure 4.
4. Pull out the plug - position 2 figure 4 - for the flat cable for the display PCB on the control PCB.
5. Disconnect the protective earth wire - position 3 figure 4.
6. Unscrew the screws for the gas spring - position 4 figure 4.
7. Unscrew the screws for the front shield - position 5 figure 4.
8. Remount the front shield in the reverse order, and continue with section 6.2 step 1 below:

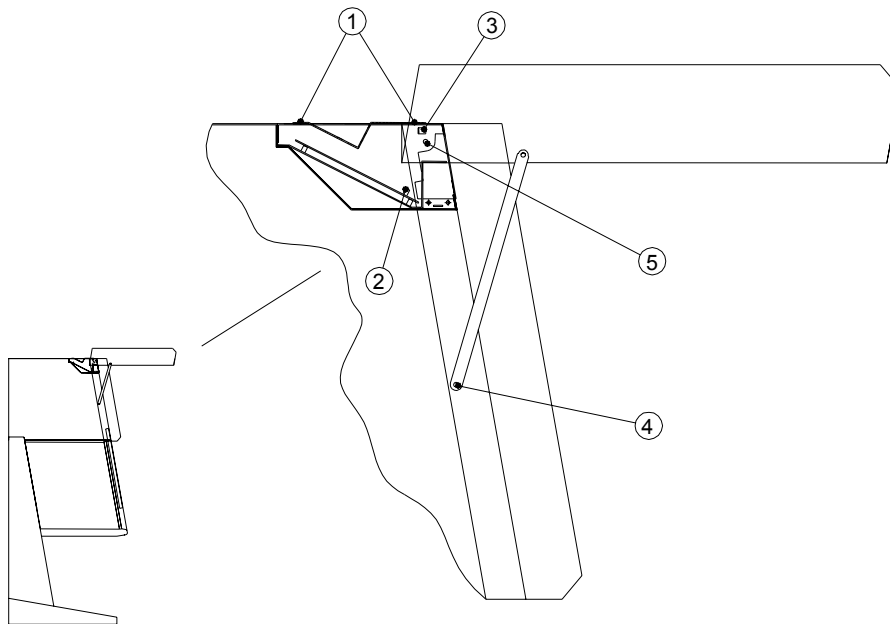

Figure Fejl! Ukendt argument for parameter.. How to dismantle the front shield.

6.2. Preparation



WARNING

The installation site for the unit must be draught-free and should be selected so that frequent passing of people in front of the work opening is avoided.

1. The tabletops of stainless steel are mounted over the trough.
2. Adjust the levelling screws to assure that the tabletop is in horizontal position and levelled.
3. Valves for gases or vacuum are installed in the side windows. A qualified technician must make the connections for the supply.
4. For connection of the exhaust air to the exhaust air systems, special precautions which must be discussed with the cabinet supplier, must be taken.
5. The armrest has to be mounted over the perforated holes.

When the cabinet has been installed:

1. Check that the front window is in the correct position, i.e. parallel to the front shield.
2. Never lift the front window manually, as this will cause the safety latch to engage.
3. Check that the window slides from top to bottom without any irregular sound.
4. If the window does not move when the UP or DOWN button is pressed, authorised service personnel must be called to correct the fault.
5. Always keep hands and arms away from the working chamber when activating the front window.

6.3. Connections

Required fusing: Circuit breaker 16 A or fuse T 16 A.

In addition, the applicable safety requirements of the local power Supply Company shall apply.

**WARNING**

If an automatic relay for disconnection of power in case of electric fault is needed, it must be installed in the supply, as it is not built-in.

**WARNING**

Before connecting the power supply it must be checked that the mains specifications correspond to those stated on the type plate.

**WARNING**

The safety cabinet is provided with a flexible power cord. The connection may be installed hard-wired or by means of a wall outlet with protective ground.

If a hard-wired connection is used, a main switch, which will cut off all poles to the unit, must be used. This switch must be lockable both in the ON and OFF positions.

If the unit is connected through a protective-ground wall outlet, the connector has the all-pole insulator function. The wall outlet is to be installed out of reach of operators and may only be accessible to authorised personnel.

7. Testing

Perform tests after installation or change of location and before the initial start-up.

**WARNING**

According to the standard EN 12469 and DIN 12980, the following must be tested:

- Check that manufacturer's specifications are met.
- Air velocity in laminar flow.
- Leakage test of the main and exhaust air filter.
- Air inlet speed in the work opening.
- Check airflow patterns.
- Optionally a KI-Discus test for testing operator protection on site.

All tests have to be done by an authorised test technician.

The test results must be entered in a test book.

For more information about testing please consult the service manual.

7.1. Air velocity in laminar flow

Equipment:

The down flow is measured with a calibrated thermo anemometer.

Procedure:

Turn on the cabinet and wait until the airflow has been stabilised.

The thermo anemometer is placed in the measuring spot in a height 50 mm over the upper edge of the front opening.

The measuring spots are the same at both SAFE and MaxiSAFE.

Measure in 2 rows 150 mm and 350 mm from the sucking holes in the front of the working plate, starting 150 mm from the left side window and with 300 mm between the measuring spots.

On the left side of the working plate the measuring probe shall point left parallel to the back wall, and on the right side of the working plate the measuring probe point right parallel to the back wall.

Each point is to be measured in at least 5 sec. and the value is to be recorded.

Calculate the mean value; record it as well as the maximum and minimum airflow.

Acceptance:

Mean downflow 0.40 m/s \pm 10 %.

Distribution: All velocities between mean \pm 20 % m/s.

Alarms:

The alarms for high and low downflow are set to mean \pm 20 % m/s, and the matching voltage is to be recorded.

7.2. Air velocity in inlet and exhaust opening

Equipment:

The inflow is measured with a suitable volumetric measuring device.

Procedure:

The measuring can take place directly in the opening or directly at the exhaust filter.

Cover the front opening with a plate and seal it so only an opening for the measuring device is free.

Measure the volumetric flow and calculate it into velocity in m/s, and record the result.

Formula for the calculation: $X \text{ m}^3/\text{h} / (3600\text{s}/\text{h} \times \text{aperture in m}^2) = Y \text{ m}/\text{s}$.

Acceptance:

Air velocity in inlet $\geq 0,4$ m/s.

	S/MS 0,9	S/MS 1,2	S/MS 1,5	S/MS 1,8
0,4 m/s =	258 m ³ /h	344 m ³ /h	430 m ³ /h	516 m ³ /h

Alarms:

The alarm for inflow velocity is set to 0,4 m/sec, and the matching voltage is to be recorded.

The acoustic alarm is tested in accordance with DIN EN 457, measured 0.5 m from the middle of the cabinet 1.5 m over the floor. The alarm signal must be at least 13 db(A) higher at 4000 Hz than the sound of the cabinet.

7.3. Airflow patterns, visualisation

The purpose of the test is to verify that no smoke escapes from the working space to the room, and that smoke will be drawn into the working space from the room.

Equipment: Smoke stick.

Procedure:

Pass the smoke stick in an easy movement along the front opening outside the cabinet. The smoke must be drawn into the cabinet without visible turbulence.

Test the laminarity of the downflow and along the side- and back wall. No smoke must come out in the room and only small turbulence must be observed.

7.4. Test of filters**Equipment:**

Aerosol generator capable of producing test aerosol for HEPA filter leak testing. Aerosol photometer with an upper measuring threshold of 10 $\mu\text{g/l}$ to 100 $\mu\text{g/l}$ and a range covering not less than 5 log rates.

Test aerosol: POA (Poly-Alpha Olefin).

Emery 3004 from Henkel Company or an equivalent material.

Procedure:

Main- and exhaust filter:

Turn on the cabinet and induce the aerosol through the "challenge" valve to the upstream side of the filter.

Scan the downstream side of the filter over the entire surface. Scan all filter joints and sealant for leaks.

Pre-filters (Maxi):

Turn on the cabinet in reduced speed mode, and let the airflow stabilise. Remove the tabletop. Cover half of the pre filters. Adjust the concentration over the "challenge" piece to 0. Every single pre-filter is "challenged" with test aerosol, and all joints and surfaces are tested.

Acceptance:

Maximum local penetration: 0.01 % of upstream concentration.

7.5. Test of the retention at front opening

General:

This test is optional, but useful for determination of the operator protection after installation where the cabinet is under influence of the laboratory environment.

Equipment:

KI – Discus tester, equipment that with an aerosol challenges the air curtain, established by the down- and inflow.

Procedure:

With a spinning disc the test aerosol (Potassiumiodide 1.5 % in Ethanol) is spread inside the cabinet, in a homogeneous aerosol cloud. The particles leave the disc in a horizontal course, and try to pass the air curtain.

A sucking head with a filter inside, catches particles which pass the air curtain,. With a developing agent (Palladiumchloride 0.1 %) passing particles will shows up as brown spots. The amount of spots is to be counted.

Acceptance: $A_{pf} \geq 1 \times 10^5$.

8. Work rules

8.1. Before start-up

- The cabinets may only be operated at temperatures between 15 °C and 35 °C, at maximum 80 % relative humidity, and at normal air pressure.
- All cabinets are developed and produced for use in clean environments.
- They must not be operated outdoors or in environments with extreme air pollution. The safety cabinets are not intended to filter vapours containing acids or organic solvents. The safety cabinets must not be used as a fume hood.
- Approximately 15 minutes before any work in the cabinet, the fan of the unit must be switched on at normal velocity. The work chamber and the front- and side windows are to be carefully cleaned and disinfected. Use an ethanol solution or similar. It is recommended to use special lint-free material. Do not use explosive disinfectants. See also section **Fejl! Ukendt argument for parameter..**
- Objects and appliances must be carefully cleaned or disinfected before being introduced into the work chamber. Do not bring in writing utensils, packing material, etc.
- The front window and the armrest is positioned in working position and kept in that position during the entire work process.
- Necessary appliances for use during work must be placed within easy reach.
- Secures the appropriate protection of the operator as well as the product (e.g. clothes, gloves, etc.).

8.2. While working



WARNING

Important for work with environmentally harmful substances!

- Do not perform work while the fan is running at reduced speed.
- The front window must be in work position during working hours.
- Place the product behind the perforated area of the work surface.
- Work with calm, smooth movements.
- Never overload the work chamber, reduce the number of transfers into and out of the work chamber.
- Avoid products or agents with high heat emission.
- Avoid a cabinet location where personnel frequently pass and avoid draughts.



WARNING

The efficiency of the laminar airflow in the work chamber is essential for personnel and product protection. Negative influences of the flow conditions must therefore be avoided. They primarily arise due to:

- Rapid movements of the operator's hand, arm, or body both in and in front of the work chamber.
- Covered vents in the tabletop of the worktable or covered vents at the bottom of the work chamber back wall.
- Large objects and apparatus.
- Devices making rapid movements e.g. agitators, centrifuges.



WARNING

Do not damage the main filter in the ceiling of the work chamber by mechanical objects or heat sources, otherwise the microbiological safety is no longer ensured.

The acoustic and optical monitoring devices of the fan and front window must not be deactivated. The enclosed armrest has to be used in order not to cover the perforated holes.

Devices developing strong heat, e.g. burners. If burners cannot be avoided, use safety burners. Operate heat sources only with the cabinet fan activated.

8.3. After work

- Remove objects and appliances from the work chamber.
- Clean the work chamber, remove fluids, if any, from the trough and dry it. Disinfect if required.
- Leave the cabinet fan in operation for about another 10 minutes.
- Close the front window to its lowest position.

9. Control Panel

9.1. Control Panel

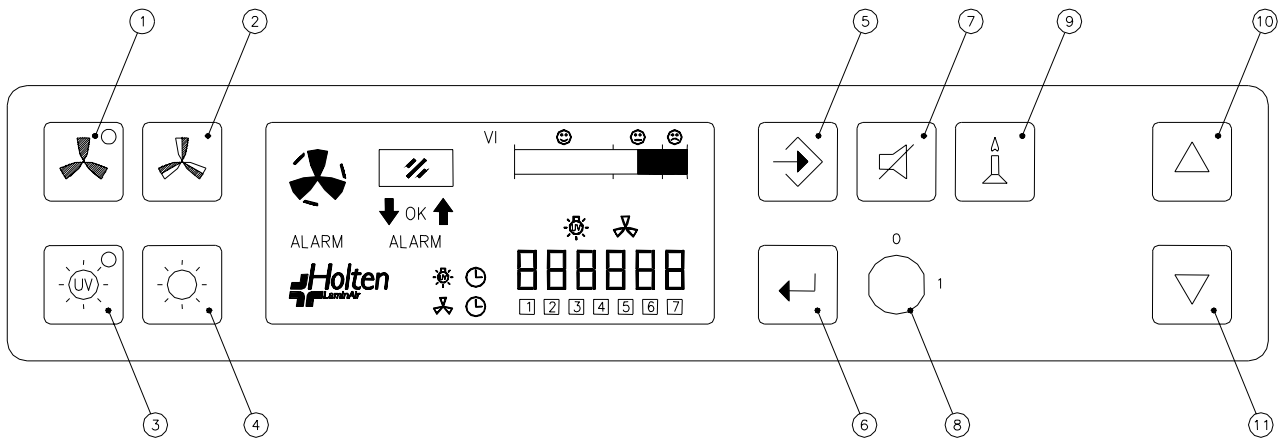

1. Button with green LED light to select the fan ON/OFF at normal velocity. The green light indicates that the fan is running at normal velocity, and that conditions are safe.
2. Button to select the fan ON/OFF at reduced velocity.
3. Button with yellow LED light to select UV light ON/OFF. The yellow light indicates that the UV light is ON. (UV light and matching UV timer for radiation time is optional).

	<p>NOTE</p> <p>For increased safety against unintended UV radiation which will harm eyes and skin: the front window must be closed in the lowest position and normal light must be switched off before UV light can be switched on.</p>
---	--

4. Button for normal light ON/OFF.

	<p>NOTE</p> <p>For increased safety reduced velocity will turn the light OFF. When the light is switched ON at reduced velocity the fan will be forced to normal velocity.</p>
---	---

5. Button for programming the clock, automatic start up or the UV timer.
6. Button for entering data.
7. Button to silence the acoustic alarm. The alarm cannot be muted while cabinet is in operation mode.

NB! Muting of the alarm is possible on the DIN 12950 approved cabinets.
8. Key switch for prevention of any unauthorised switching ON or OFF of the fan.
9. Button to OPEN/CLOSE the solenoid gas valve (optional).
10. Button for opening of the front window. In programming mode used for increasing data value.
11. Button for closing of the front window. In programming mode used for decreasing data value.

9.2. LCD Display

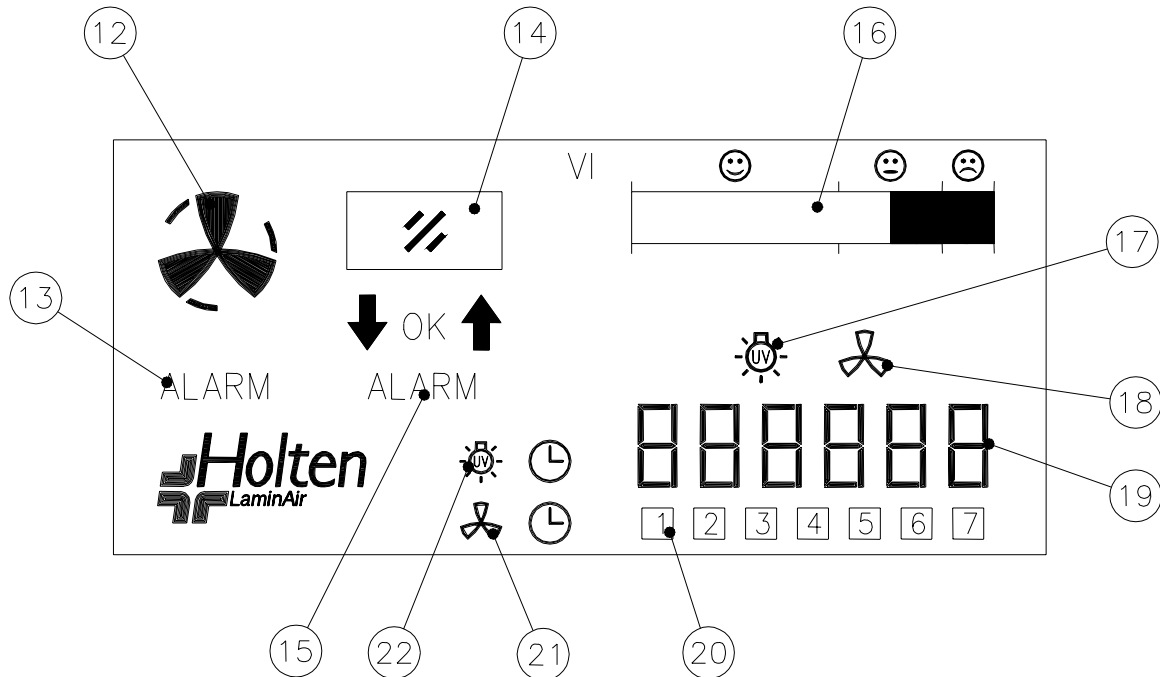

12. Fan velocity: Normal, Reduced, or Stop.
13. Air velocity not within safe limits. The icon flashes, the acoustic signal sounds and flashing red light comes on.
14. Front window (sliding sash).
15. Front window not in safe position. The icon flashes, the acoustic signal sounds and flashing red light comes on.
16. Indication of vertical air velocity in the work chamber (service meter).
17. This icon will illuminate when the UV timer is being programmed.
18. This icon will illuminate when the automatic start-up timer is programmed.
19. Hour counter or clock with fan switch ON or OFF.
20. Indication of weekday.
21. This icon will illuminate when the automatic start-up is programmed and active.
22. This icon will illuminate when the UV timer is activated.

9.3. Bar graph

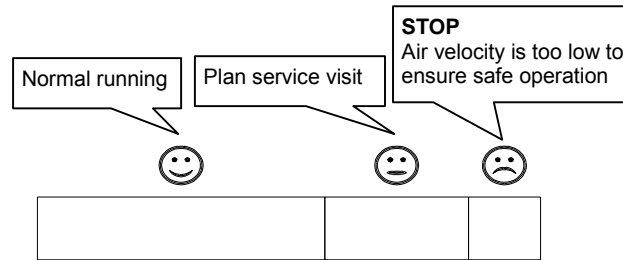











The flow graph will illuminate with segments in the * area when the filter is new and clean. Gradually as the filter becomes clogged and the air velocity decreases the segments will be turned off.

Please contact your supplier for further information on test procedures.









9.4. Operation



	<p>NOTE During programming the display will return to normal mode if the interval between activation exceeds 30 seconds. Also note that the clock operates with 24-hour indication only.</p>
---	---

Setting the time and weekday

Disconnect the power; keep  activated whilst reconnecting the power. Now the 2 digits for minutes start flashing, use  or  to adjust the minutes and  to accept the setting. Now the 2 digits for hours start flashing, use  or  to adjust the hour setting and  to accept the setting. Finally set the weekday using  or  to adjust the weekday and  to accept the setting. Now the time of day will be displayed in 24-hour mode and the weekday as 1 to 7 with 1 being Monday.









Setting the automatic fan start up

Keep  activated and press  once, the icon  above the digits will now be ON. Set the desired start time by adjusting the setting using  and   to advance from minutes to hours and to weekday by using  or  the possible settings are: day 1 or day 2 or day 3.....to day 7, days 1 to 5, days 1 to 7, no day displayed indicates that automatic start up is switched off, press  to accept the setting.

The icon   indicates that the function is active.

Remember to set the front window at normal work height (200 mm). The fan will now be switched on at normal velocity to the pre-set time and will continue to be switched on at normal velocity until it is manually switched off.



Setting the UV timer (UV timer optional), UV switched on.

Keep  activated and press  once, icon  above the digits will now be switched on. Set the desired OFF time for the UV light by adjusting the setting using , , and  to advance from minutes to hours (OFF time can be set from 1 minute to 23 hours and 59 minutes). The icons   next to the 24-hours digits, indicate that the timer is set.

Use  to leave the menu.

In order to switch on the UV timer, first position the front window at its lowest (closed) position and switch off the light. After activating the UV light button the UV light and the yellow LED-light in the button will be switched off to the pre-set time.

Front window

The unique double function front window is operated via  and . When a button is activated the display indicates if the window is opening or closing. By a short activation of  the window will open automatically in 2 steps:

1. From closed to normal work height (200 mm).
2. From normal work height to fully open. From this position it is possible to close the window to normal work height (200 mm) by a short activation of .

For safety reasons it is only possible to close the window completely by keeping  activated. Note that the window will be pulled against the window gasket in positions closed and normal work height. This gives a few seconds delay prior to window movement, when activated from these positions, check the display to see if the automatic OPEN/CLOSE programme is initiated (Display will show OPEN or CLOSE).

3. The fan will automatically switch to reduced speed if the window is closed with the fan running at normal speed.

	<p>NOTE</p> <p>When the cabinet is connected to an active exhaust system or the internal fan is switched on at normal velocity with the front window in closed position, the under-pressure inside the cabinet may obstruct the proper function of the front window when opening from this position.</p>
---	---

In case of improper function, switch off the fan, or switch to reduced velocity, open the front window, switch back to normal velocity.

Key switch

Normal and reduced velocity ON/OFF buttons for the fan may be deactivated in order to prevent any unauthorised change in fan status. However it is possible with the key switch in lock position to change the fan velocity from reduced to normal velocity but not vice versa.

9.5. Supervision - Alarm

The cabinet safety is constantly supervised so that any deviation from safe conditions or any fault in the supervision system will be indicated immediately.

Safe conditions are indicated by a green LED light in the button for fan at normal velocity.

Unsafe conditions will be indicated both acoustically and visually by red flashing display light. The alarm will be initiated if:

- The vertical air velocity inside the work chamber is outside the limits stipulated in the relevant standards.
- The horizontal in-going air velocity in the work opening is below the limits stipulated in the standards.

- The front window is not in correct work position, i.e. opening exceeding 200 mm.
- The fan is running at reduced velocity.

The acoustic signal can only be silenced by activating  when the cabinet runs at reduced speed.

The alarm will be muted during start up of the fan.

The flashing display light will be turned off when all conditions are safe again or the cabinet is switched off.

10. Cleaning and decontamination

10.1. Daily

Cleaning must be done daily after work in order to obtain a safe working environment.

The cabinet should be kept clean and free from unnecessary equipment.

All accessible parts of the cabinet is made without sharp edges, corners and without sharp angles, but attention should be taken also at the outside surfaces where joints and welding is to be carefully cleaned.

The interior should be swabbed with a suitable disinfectant with the right biological spectrum after use. Phenol's, quaternary ammonium compounds and aldehyde can be used for disinfecting these surfaces. Recommended disinfectants are 2 % (vol.) gluteraldehyde or 15 % (vol.) formaldehyde. Use alcohol's on caution because of the risk of fire.

Heavy duty polyvinyl chloride (PVC) or rubber gloves which provide suitable protection for the hands and wrists and which can be disinfected for re-use should be worn when cleaning the cabinet.

Procedure:

1. Leave the cabinet running at normal speed. Turn on the light.
2. Remove objects and appliances from the work chamber.
3. Lift up the table tops one by one and clean them carefully on both sides. Remove them from the working chamber.
4. Remove all loose objects from the trough and flock filter (not applicable on MaxiSAFE).
5. Swab the trough carefully on surfaces, along edges and in corners.
6. Clean the back wall, the stainless steel panel and the side windows. Use an atomiser between the back wall and the outlet panel, and leave the disinfectant for 5 minutes.
7. Rise the sliding front window to the highest position using the panel and open the front shield.
8. Clean the window on the inner side.
9. Close the front window.
10. Put the clean tabletops back in their place.

11. Let the fan run for 10 minutes.

10.2. Weekly

Wipe the outside of the unit with a mild household cleaner. Anti-static spray may be used to clean the front window.

10.3. Regularly

Reliable function of the cabinet and compliance with standards are based on the following conditions:

1. Correct air velocities.
2. Efficiency of the HEPA filters installed.
3. Correctly adjusted alarm limits.
4. Tightness of the construction.

10.4. Decontamination by use of formaldehyde

The purpose of this section is to state guidelines regarding decontamination by using formaldehyde.

This method is not applicable for cabinets in which activated charcoal filters are installed.

**NOTE**

Certification is required in certain countries for decontamination by using formaldehyde.

Procedure for decontamination by use of formaldehyde

1. Dismantle the exhaust system.
2. Place the decontamination apparatus on the work surface inside the cabinet.
3. Make sure that the key for the cabinet is in its place.
4. Mount the tent over the cabinet. Be careful so no holes appear in the folio.
 - The bottom of the tent is in one piece and two slits must be cut outside of the cabinet legs, so it is possible to carry the folio to the backside of the cabinet.
 - Tape the slits in the bottom folio together with the special tape. Be very careful with the sealing of the levelling base.
 - Pull the wire for the power connection to the front of the cabinet.
 - Mount the tent over the cabinet – be careful not to make holes in the folio – and pull it carefully to the bottom folio.
 - Put up the telescopic bars in each corner and tape the tent on to them. Fix the top of the tent with tape so the tent just reaches the bottom folio.
 - Tape the sides of the tent to the bottom folio, starting with the backside of the cabinet, and take care of a good tightening in the corners.

- Cut a triangle hole for each of the wires for the cabinet and the decontamination apparatus and tape carefully around the wires.
 - Cut a triangle slit for the dosage of water, formaldehyde and ammonia. The opening must be carefully taped after use.
5. Start the decontamination apparatus.
 6. After ½ an hour, start the ventilator on reduced speed for one hour so the formaldehyde can be distributed in the cabinet.
 7. The decontamination process will run for 8 hours including the neutralisation of the formaldehyde with ammonia.
 8. Dismantle the tent and pack it together in the transportation back and handle it as hazard waste.
 9. End of process.

Table of dosage:

Model	Formaldehyde 37 %	Water	Ammonia 25 %
0.9	30 ml	30 ml	20 ml
1.2	40 ml	40 ml	27 ml
1.5	50 ml	50 ml	33 ml
1.8	60 ml	60 ml	40 ml

Decontamination procedure:

Formaldehyde evaporation	30 minutes
Distribution time	1 hour
Decontamination incl. neutralisation	8 hours

Equipment:		Catalogue number
Tent 0.9 - 1.2		88 832515
Tent 1.8		88 832517
Telescopic bars (4) height to the ceiling:	2020-3450 mm	88 881345
Bar extensions (4) (In the height)	1000 mm	88 881346
Decontamination apparatus		51 890078
Tape	TESA 4613	88 804012

11. Maintenance



WARNING

Every 5000 operating hours or at least once every year the cabinet has to be inspected and tested.



WARNING

Before repair work is carried out inside the contaminated and/or infected cabinet and prior to filter replacement and upon change of location, proper cleaning and disinfecting by the operator is required. The Lab-Manager/Safety Manager must confirm this in writing to service personnel. For the appropriate form, refer to section 13.

After completion of work, tests are required according to standard.

- Leakage test of main and exhaust air filter.
- Test and adjust air velocities and alarm settings in the vertical flow inside the work chamber and the horizontal in-flow in the work opening.
- Test of air patterns.
- General function and safety tests in accordance with local requirements. For this purpose we recommend a maintenance agreement.

Before work on the electrical system, disconnect the power.

Fuses are easily accessible and situated on top of the cabinet.

All maintenance and repair work performed, as well as filter replacements and required tests, must be documented in a test book. See section 12.

11.1. Filters



NOTE

The HEPA filter is very fragile. Even a light touch may damage the filter.



WARNING

In order to avoid any possible harm, it is recommended that while changing filters the service technician wear a mask with filter of HEPA quality. (H 13 or better).

The used filters must be placed in special bags for biohazard waste immediately after removal. The special bags should be handled as toxic material and sent for destruction as the normal toxic waste from the lab.

11.1.1. Main and exhaust filter exchange

Equipment required

Screwdriver for Phillips screws number 2.
 Wrench size 13 mm.
 Soap and water.
 2 cable and wire ties.
 Nipper.
 Filters. See schedule below.

11.1.2. Procedure for replacement of main filter

1. Position the front window in the upper position.
2. Open the front cover.
3. Disconnect from mains.
4. Using the screwdriver dismantle the front cover, avoid the cover falls.

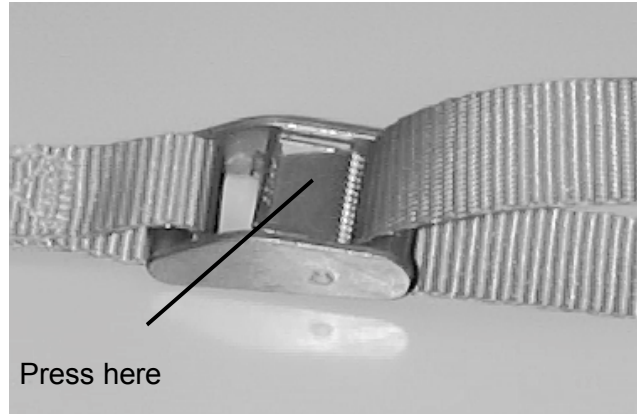

Figure 5.

5. Loosen the belts at both sides by pressing the buckle as illustrated (figure 5).
6. Fasten the triangular eyes at each of the corners in the iron frame.
7. Guide the belts over the 2 pulleys internally in the fan house.
8. Lift the plenum by pulling the belts.
9. Remove the filter. The filter may stick to the cabinet frame. To facilitate its removal, press by flat hand under the filter cloth. In case this is not successful the filter can be removed by using a large flat screwdriver or similar. Be careful not to damage the frame. A plastic plate may be used for protection.
10. Install the new filter. The installation is facilitated by application of soap water to the gasket.
11. Lower the plenum (figure 6).



Figure 6.

12. Free the triangle eyes from hooks and belts.
13. Reconnect the belts to the lower hook in front.
14. Tighten the belts and lock the cam buckle by lifting up the pawl.
15. Coil the belts and fasten them with the cable and wire ties.
16. Reinstall the front cover.

11.1.3. Procedure for replacement of exhaust filter

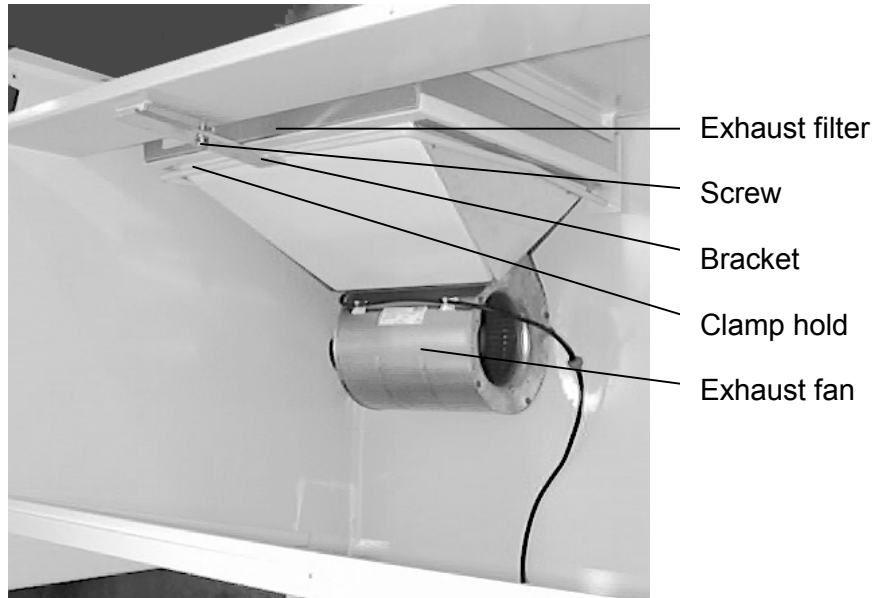

Figure 7.

1. Position the front window in the upper position.
2. Open the front-cover.
3. Disconnect from mains.
4. Using the screwdriver dismantle the front cover, avoid the cover falls.
5. Loosen the screw in front of the filter in order to remove the rails from the frame.
6. Remove the rails and the screw completely using the size 13-mm wrench.
7. Remove the filter without damaging the gasket.
8. Install the new filter.
9. Tighten the frame by suspending it while the rails are moved into place.
10. Check from above that the filter is positioned correctly with the gasket positioned equally on all surfaces.
11. Tighten the screw until the gasket has a good contact to all sides.
12. Reinstall the front cover.

11.1.4. Pre-filter (MaxiSAFE Only)

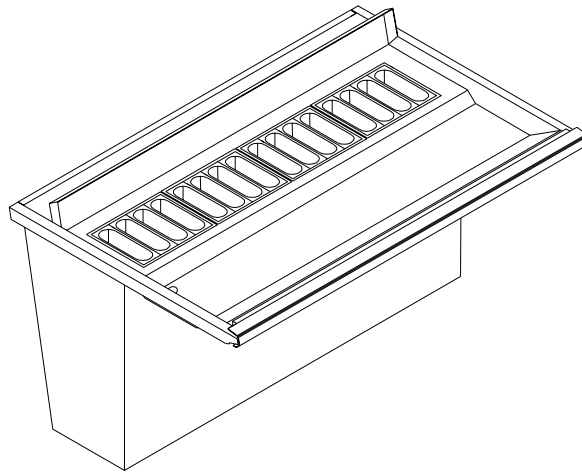

Figure 8.

Equipment required

50-mm wide tape.
Stanley knife or similar.
Filters (See the Instruction Manual).
Silicone.

Procedure for replacement of pre-filter

1. Position the front window in top position.
2. Turn the fan on at reduced speed.
3. Remove the tabletops.
4. Seal the intake openings of the filters with tape.
5. Cut the tape and silicone sealant found between filters and frame.
6. Carefully remove the filter/filters as applicable.
7. Install the new filters.
8. Seal the crevice between filter and trough with a silicone sealant, then tape the top of the sealant between the filters.
9. Test the cabinet according to recommended test procedures.

11.2. Part list for filter

The cabinets have all been tested and approved with main and exhaust filters from both Cofim and Camfil.

Note that main and exhaust filters must be of the same make at exchange.

Main filter: Efficiency 99.999 % at 0.3 μm . H14 according to EN 1822-1.

Exhaust filter: Efficiency 99.999 % at 0.3 μm . H14 according to EN 1822-1.

Pre-filter: Efficiency 99.99 % at 0.3 μm . H13 according to EN 1822-1.

Please note that the pre-filters have the same internal part number for both Luwa and Camfil.

Cabinet size		0.9	1.2	1.5	1.8
Main filter	Cofim All	82700003 NWHFAB8HLPDLV 610x915x68	82700004 NWHFAB9HLPDLV 610x1220x68	82700005 NWHFAB10HLPDLV 610x1525x68	82700006 NWHFAB11HLPDLV 610x1830x68
	Camfil EN 12469	82200453 MD 50 LA 33 GV 915x610x66-1 PU	82200454 MD 50 LA 33 GV 1220x610x69-01PU	82200455 MD 50 LA 33 GV 1525x610x66-1 PU	82200456 MD 50 LA 33 GV 1830x610x66-1 PU
	Camfil DIN 12950	82200003 MDLA-GW 915x610x66-1 PU	82200004 MDLA-GW 1220x610x69-01PU	82200005 MDLA-GW 1525x610x66-1 PU	82200006 MDLA-GW 1830x610x66-1 PU
Exhaust filter	Cofim All	82700519 NWHFAB43HLPD 457x457x68	82700519 NWHFAB43HLPD 457x457x68	82700520 NWHFAB41HLPD 457x610x68	82700521 NWHFAB47HLPD 457x762x68
	Camfil EN 12469	82200419 MD50A33-2GW 457x457x69-01PU	82200419 MD50A33-2GW 457x457x69-01PU	82200420 MD50A33-2GW 457x610x69-01PU	82200421 MD50A33-2GW 457x762x69-01PU
	Camfil DIN 12950	82200519 MDA-2GW 457x457x69-01PU	82200519 MDA-2GW 457x457x69-01PU	82200520 MDA-2GW 457x610x69-01PU	82200521 MDA-2GW 457x762x69-01PU
Pre- filter	Luwa	9x82200029 PB 'Glas' 411.50.0070	12x82200029 PB 'Glas' 411.50.0070	15x82200029 PB 'Glas' 411.50.0070	18x82200029 PB 'Glas' 411.50.0070
	Camfil	9x82200029 3326.01.02 013223	12x82200029 3326.01.02 013223	15x82200029 3326.01.02 013223	18x82200029 3326.01.02 013223

On the cover plate under the front cover, the actual filter type and serial no. Is registered.

11.3. Activated charcoal filters (Optional equipment)

Equipment required

12 Filter cartridges.

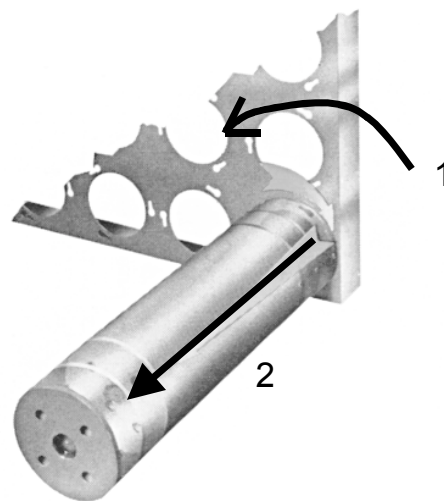

Figure 9.

Procedure for replacement of activated charcoal filters

1. Dismantle the cover from the filter box.
2. The charcoal cylinders are fastened with bayonet sockets. Place the special bag over one of the cartridges. Turn the cartridges clockwise and remove it from the frame. Proceed as above until all activated charcoal filters have been removed.
3. Install the new charcoal filter cartridges in the filter box.
4. Reinstall the cover.
5. Rinse all tools used. Protective cloth and filter for filter masks are to be placed in a bag for toxic waste.

11.4. Fuses

The fuses of SAFE 2010/MaxiSAFE 2010 are located in the right side of the top of the cabinet. In cabinets produced subsequent to August 1999 an additional 2 fuses are located under the protective cover above the electromechanical panel. These 2 fuses secure zero to light and UV light. The remaining fuses on the Controller board PCB secure:

Component	Fuse	Phase/zero
Main	T10A	Phase
Main	T10A	Zero
Electrical outlet	T6.3A	Phase
Electrical outlet	T6.3A	Zero
Option 1	T1A	Phase
Option 2	T1A	Phase
Option 3	T1A	Phase
Light	T1A	Phase
UV-light	T1A	Phase
Fan	T6.3A	Phase

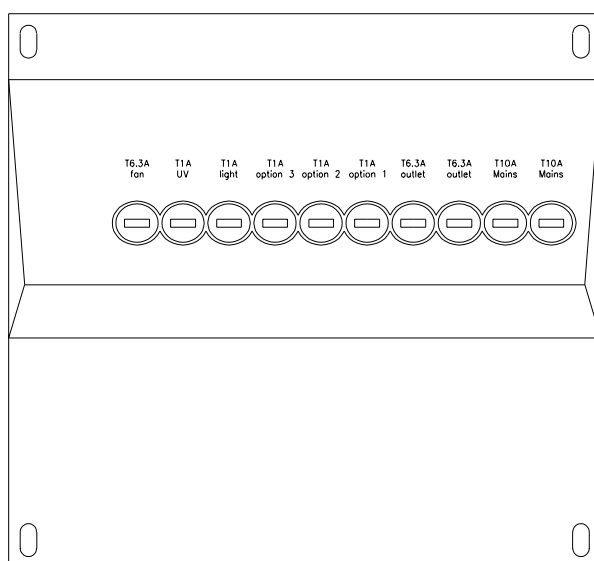

364231.wmf

Figure 10a.



Figure 10b.

Equipment required

Small screwdriver for slotted screws.

Fuses (see the Instruction Manual).

Procedure for replacement of fuses

Turn the fuse retainer counter-clockwise, remove the fuse and replace it.

11.5. Fluorescent light tube



Figure 11.

Equipment required

Phillips screwdriver.

Fluorescent light tube.

Procedure for fluorescent light tube replacement

1. Remove the reflector by lifting it and then pulling it out.
2. Unscrew the 2 screws to the left and take the fitting out.
3. Exchange the Light tube.
4. Reassemble in reverse order.

11.6. Starter



Figure 12.

Equipment required

Starter.

Procedure for starter replacement

1. Remove the reflector.
2. Replace the starter in the right fitting.

11.7. Electrical spare parts

Cabinet size	0.9	1.2	1.5	1.8
Fluorescent lamp 30-36-58W/83	844035	844027	844028	
UV light tube type TUV 15-30W	844030		844031	
Starter for both FSU 4-80W	844086			
G-fuse 5x20 mm T 10A, 250 Volts	841274			
G-fuse 5x20 mm T 6.3A, 250 Volts	88851096			
G-fuse 5x20 mm T 1A, 250 Volts	88851097			

We:

Jouan Nordic A/S
Gydevang 17-19, DK-3450 Allerød
Denmark

declare under our sole responsibility that the product

Model: **SAFE 2010/MAXI SAFE 2010**

to which this declaration relates is in conformity with the following standard(s) or other normative document(s):

EN 292-1:1991 - Safety of machinery.
Basic concepts - General principles for design.
(Basic terminology, methodology)

EN 292-2:1991 - Safety of machinery.
Basic concepts - General principles for design.
(Technical principles and specifications)

EN 60204-1:1999 - Safety of machinery - Electrical equipment of machines.
(General requirements)

EN 61010-1: 2001 Safety requirement for electrical equipment for measurement, control and laboratory use.
(General requirements)

EN 61000-6-4:2001 and EN 61000-6-2:2001 - Electromagnetic compatibility.
(Generic standards - Emission / Immunity for industrial environment).

EN 1050:1996 - Safety of machinery.
(Principles for risk assessment).

following the provisions of:

Directive **98/37/EEC** Machinery

Directive **73/23/EEC** Low voltage

Directive **89/336/EEC** Electromagnetic compatibility

Allerød, 2002.12.06

Jan Bøger, Managing Director