





SERVICE MANUAL
Heto-Holten A/S
BIOSAFE 1.2/1.2NF/1.2BS
ID: 807242

Symbols used in this manual

	WARNING Used in case of danger of a serious accident or when documentation needs to be consulted.
	NOTE Used to direct attention to a special item.

© Copyright 2001

HETO-HOLTEN A/S
Gydevang 17-19
DK-3450 Allerød
Denmark

Telephone +45 48 16 62 00
Fax +45 48 16 62 97
e-mail info@heto-holten.com

Home page: <http://www.heto-holten.com>

Table of contents

1.	Introduction	4
2.	Test and adjustment procedures	4
2.1.	Leak tests.....	4
2.1.1.	Equipment required.....	4
2.2.	Procedure when using a particle counter	4
2.3.	Procedure when using a photometer	5
2.4.	Air velocity test.....	6
2.4.1.	Equipment required.....	6
2.4.2.	Procedure for air velocity test in unidirectional flow	7
2.4.3.	Procedure for air velocity test in the work opening	7
3.	Down flow alarm adjustment.....	8
3.1.	Procedure for low alarm adjustment.....	9
3.2.	Procedure for high alarm adjustment.....	10
3.3.	Makeup alarm adjustment	10
3.3.1.	Procedure for makeup alarm adjustment.....	10
4.	Decontamination by formaldehyde.....	10
4.1.	Procedure	11
5.	Dismantling and replacement instructions	11
5.1.	Fuses	12
5.1.1.	Procedure for replacement.....	12
5.2.	Fluorescent light tube	12
5.2.1.	Procedure for replacement (Biosafe 1.2/1.2 NF)	13
5.2.2.	Procedure for replacement (Biosafe 1.2 BS)	13
5.3.	Starter	13
5.3.1.	Procedure for replacement (Biosafe 1.2/1.2 NF)	14
5.3.2.	Procedure for replacement (Biosafe 1.2 BS)	14
5.4.	Access to internal plenum	14
5.4.1.	Procedure	14
5.5.	Filters	15
5.5.1.	Procedure for replacement of main filter on BIOSAFE 1.2/1.2 NF	15
5.5.2.	Procedure for replacement of exhaust filter on BIOSAFE 1.2/1.2 NF	15
5.5.3.	Procedure for replacement of main filter on BIOSAFE 1.2 BS.....	16
5.5.4.	Procedure for replacement of exhaust filter on BIOSAFE 1.2 BS	16
5.6.	Access to the electric compartment.....	17
5.6.1.	Procedure	17
5.7.	Fans.....	17
5.7.1.	Procedure for replacement of the fan	18
5.8.	Controller board PCB	18
5.8.1.	Procedure for exchange of the PCB.....	18
5.9.	Key switch.....	18
5.9.1.	Procedure for replacement of key switch.....	18
6.	Electric diagram	19
7.	Setting the auto transformer for the fan	20
7.1.	Procedure for setting air velocity	20
8.	Spare parts	21

1. Introduction

This Service Manual for BIOSAFE 1.2, BIOSAFE 1.2 NF and BIOSAFE 1.2 BS is meant to assist in performing service. It is to be used in conjunction with the Instruction Manual.

2. Test and adjustment procedures

The test procedures are only given as guide lines. Special rules in different countries may require specific procedures.

To ensure safe operation the setting of the alarm of BIOSAFE 1.2/1.2 NF/1.2 BS should be checked/adjusted whenever maintenance/repair has been performed.

2.1. Leak tests

2.1.1. Equipment required

- Aerosol
- Aerosol generator
- Diluent and dilution equipment (if available) and Form 00184151 "Leak test of HEPA filter" may be requested from the HETO-HOLTEN A/S Service Department.

Further equipment required when using a particle counter

- Optical particle counter.
- Isokinetic sensor.
- Particle analyser.
- Optical particle counter with lower sensitivity 0.3 or 0.5 μm . Maximum 10 % double sequence of errors. Test aerosol DEHS or similar, for example generated with atomiser.
- Diluent dilution system for the particle analyser is advisable.

Further equipment required when using a photometer

- Optical photometer with lower sensitivity 10^{-3} $\mu\text{g/l}$ with 0.3 μm particle and possibility of measuring concentrations up to 10^5 times lower sensitivity.
- Test aerosol EMERY 3004.
- Aerosol generator: One or more nozzle(s) of type Laskin.
- Ratio of size of aerosol from generator: 99 % smaller than 3.0 μm , 50 % smaller than 0.7 μm and 10 % smaller than 0.4 μm .

2.2. Procedure when using a particle counter

1. Start the cabinet and let it run for at least 15 minutes at normal speed with the front window in work position.
2. Measure the concentration on the suction side of each module. This indicates workload at normal run.

3. Start the aerosol generator. Ensure that the aerosol is sucked into the opening of the filter to be tested.
4. Connect the generator to the service valve.
5. Measure the concentration of aerosol on the backside of the main filter.
6. Connect dilution equipment if available.
7. Adjust the aerosol generator until a constant value higher than 1×10^6 per ft^3 is exceeded. Record the measured concentration on the form "leak test of HEPA filter".
8. Connect the particle counter to the Isokinetic sensor and set it to measure the total number of particles. An acoustic signal is produced each time a particle is measured.
9. Move the probe with a speed of maximum 30 mm/sec keeping it about 25 mm from the area to be tested.
10. Test the area around the filter packing.
11. Test the entire filter surface.
12. Test the entire cabinet inside the clean area.
13. If particles are measured at a particular point, return to this point to measure the particle concentration and record the value.
14. Determine the highest concentration on the clean side of the filter. This result is defined as maximum permeability. Relative permeability is calculated as maximum permeability concentration measured on the unclean side of the filter.
15. Check that the value for maximum relative permeability is below maximum permissible value. Typical value 1/10000.
16. Adjustments
 - Too high permeability at a particular point or at filters packing Contact customer to arrange replacement of filter and silicone sealant.
 - Too high permeability in the construction. Make a silicone sealant, using the same colour of silicone as used during construction.

2.3. Procedure when using a photometer

1. Start the cabinet and let it run for at least 15 minutes at normal speed with the front window in work position.
2. Connect the photometer to the module to be tested.
 - Warm up the photometer.
 - Connect the photometer to the service valve or close the suction side of the fan, in such a way that the measuring represents the mean concentration on the backside of the filter.
3. Start the aerosol generator. Ensure that the aerosol is sucked into the opening of the filter to be tested.
4. Measure and record the concentration of aerosol on the backside of the main filter.

5. Adjust the aerosol generator until a value of 5µg/l is exceeded. Record the measured particle concentration on the form "Leak test of HEPA filter".
6. Adjust the photometer to indicate 100 %.
7. Adjust the aerosol generator until a value of 1x10⁶ per ft³ is exceeded. Record the measured concentration on the form "leak test of HEPA filter".
8. Set the photometer to scan with the connected Isokinetic sensor. An acoustic signal sounds if particle concentration exceeds 0.01 % or reads below 0.1 %.
9. Move the probe with a speed of a maximum of 30 mm/sec keeping it about 25 mm from the area being tested.
10. Test the area around the filter packing.
11. Test the entire filter surface.
12. Test the entire filter area by moving the probe with overlapping movements.
13. Test the entire cabinet inside the clean area.
14. If a relative permeability higher than 0.001 % is measured at a particular point, return to this point to measure the particle concentration and record it.
15. Check that the value for maximum relative permeability is below the maximum permissible value.
16. Adjustment.
 - a. Too high permeability at a particular point or at filter packing. Contact customer to arrange replacement of filter and silicone sealant.
 - b. Too high permeability in the construction. Make a silicone sealant, using the same colour of silicone as used during construction.

2.4. Air velocity test

Different ways of calibrating the measuring tools may cause discrepancies in the measuring results. Ask for the previous calibration test results.

Inaccuracies of positioning the measuring positions may cause minor changes of the values obtained.

The power supply will also influence the measuring results since the fan will give less air at lower voltage.

The measuring tool should compensate for the ambient temperature otherwise the results must be corrected.

2.4.1. Equipment required

- Anemometer (Flow Master).
- Measuring PVC pipe with inside diameter Ø160 mm.

2.4.2. Procedure for air velocity test in unidirectional flow

1. Position the anemometer on top of a stand 250-mm above the tabletop.
2. Measure the air velocity at the indicated test points shown in figure 1.

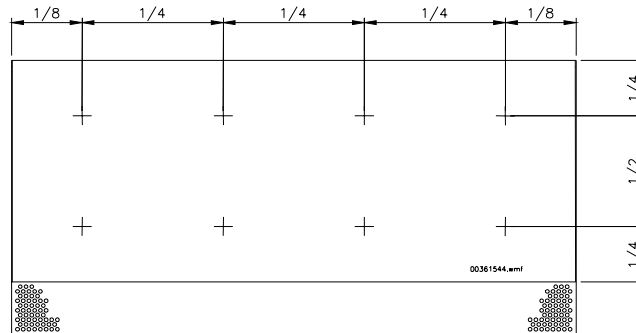

Figure 1.

3. Calculate the mean value

$$x_{av} = \frac{x_1 + x_2 + \dots + x_n}{n}$$

4. This value has to be 0.4 m/s +/-10%. As there is hysteresis in the alarm system, the values $x_1 \dots x_n$ should be between 0.34 m/s and 0.46 m/s in order to allow to adjust the alarm values which are 0.32 m/s for low alarm and 0.48 m/s for high alarm.
5. The air velocity below the main filter can be adjusted using the different settings on the autotransformer. See section 7.

2.4.3. Procedure for air velocity test in the work opening

To gain access to the alarm module PCB, see section 5.6.

1. Position the measuring pipe in the work opening. See figure 2.



Figure 2.

2. To avoid false air in the work chamber, seal off all openings around the measuring pipe with tape.

3. Place the anemometer at the end of the Ø160 measuring pipe and measure at the 5 test points. Figure 3. The average velocity in the work opening must exceed 0.4 m/second.

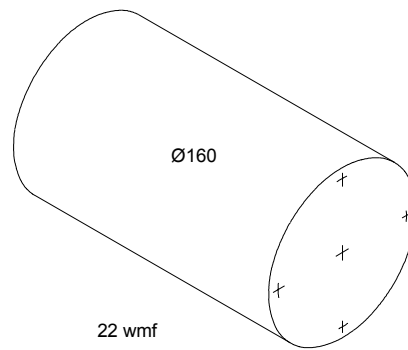

Figure 3.

4. Calculate the mean value = $(x_1 + x_2 + \dots + x_n)/n$
- Calculate the average velocity $V_{\text{work opening}} = 17 / V_{\text{pipe}}$
 - where 17 = Conversion factor.
 - V_{pipe} = Average velocity of the measurements in the measuring pipe.
 - $V_{\text{work opening}}$ = Calculated mean value of velocity.

Minimum acceptable velocity in the work opening $\sim V_{\text{min.}} = 0.4 \times 17 \cdot V_{\text{min}}$ is the velocity in the measuring pipe corresponding to 0.4 m/second in the work opening.

3. Down flow alarm adjustment

Equipment required

- Anemometer (Flow Master).
- Stand.
- Screwdriver made from plastics.
- Variable transformer or paper for covering holes.

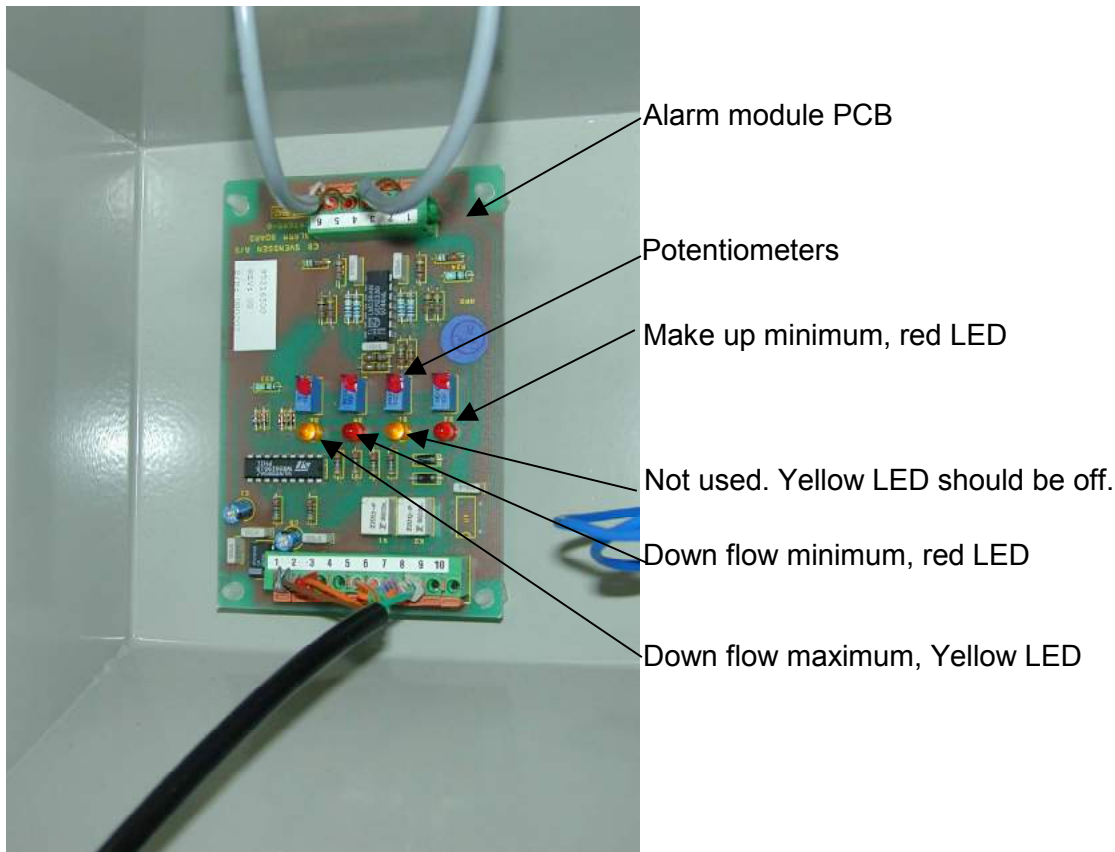

Figure 4.

3.1. Procedure for low alarm adjustment

1. Disconnect from mains.
2. Remove the cover of the front panel (See section 5.6) and you have access to the Alarm module PCB.
3. Connect to mains but be aware of high voltage in the electrical mounting box.
4. Place the anemometer upon a stand 250-mm above the tabletop.
5. Place the front window in work position.
6. Measure the air velocity in the unidirectional flow as described in section 2.4.
7. Place the anemometer where the minimum air velocity is measured.
8. Adjust the variable transformer. Decrease the air velocity until the air velocity indicator indicates 0.32 m/sec. Alternative procedure Cover the perforations in the tabletop with paper until the anemometer reaches 0.32 m/second. The perforated area must be evenly covered in order not to interrupt the airflow profile.
9. Adjust the potentiometer above the LED, which is lit, while the exhaust kit is mounted.
10. Adjust the vario transformer to 230V. In case the alternative procedure was used, remove the paper.
11. Observe the low alarm to go out.
12. Repeat step and check the alarm.

13. Let the fan run at normal speed.
14. Seal the screw of the potentiometer.

3.2. Procedure for high alarm adjustment

1. Follow step 1 to 6 in procedure for low alarm adjustment.
2. Locate the position with the highest down-flow.
3. By increasing the voltage either on the internal autotransformer or on an external variable transformer, increase the down-flow to 0.48 m/s.
4. Adjust the potentiometer on the Alarm module PCB until the yellow light just lights up. See the previous section and the illustration above.
5. Decrease the voltage until the high alarm goes off.
6. Readjust the voltage to achieve 0.48 m/s and record the voltage.
7. Let the fan run at normal speed.
8. Seal the screw of the potentiometer.

3.3. Makeup alarm adjustment

Equipment required

- Measuring tube
- Anemometer
- Screwdriver made from plastics.
- Possibly variable transformer.

3.3.1. Procedure for makeup alarm adjustment

1. Using the measuring tube determine the lowest permissible limit for air velocity 0.4 m/s in the work opening by reducing the voltage on the variable transformer or by adjustment throttle in the measuring tube.
2. Adjust the potentiometer for make up alarm so that the red light just lights up.
3. Adjust the variable transformer to 230V and check the alarm to go out.
4. Readjust the voltage to achieve 0.4 m/s and record the voltage.
5. Seal the screw of the potentiometer.

4. Decontamination by formaldehyde

The purpose of this section is to state guidelines regarding decontamination when using formaldehyde.

HETO-HOLTEN A/S is unable to guarantee a successful decontamination using this method and it should be regarded as a general and recommended method.

This method is not applicable for cabinets with activated charcoal filters installed.

	<p>NOTE Certification is required in certain countries for decontamination using formaldehyde.</p>
---	--

4.1. Procedure

1. Prepare the formaldehyde solution and install an evaporator in the safety cabinet.
2. Close the window and install the night cover. Seal all crevices on the front.
3. Connect the exhaust of the cabinet via a flexible duct to the fume hood or any suitable exhaust system.
4. Sufficient formaldehyde (see below) is evaporated inside the closed cabinet to neutralise contamination by condensing on all internal surfaces. Start the fan and the evaporation of the safety cabinet. Ammonia has to be added if the evaporator is prepared to be used for neutralisation.
5. After all formaldehyde has evaporated let the fan run for about 20 minutes, then turn it off.
6. The formaldehyde is left for at least 5 hours' influence time.
7. Remove the seal from the front window and let the fan run for about 30 minutes thereby exhausting any remaining from the decontamination process via the fume hood.
8. Remove all remaining seal used during the process.
9. The cabinet is ready for use.

Decontamination agent:

40-ml formaldehyde 37 % diluted with 40-ml water.

Possible neutralisation agents:

27 ml ammonia 25 % (See procedure for used equipment).

5. Dismantling and replacement instructions

	<p>NOTE Prior to performing any work in the chamber ensure that the cabinet is disinfected and/or neutralised (Described in section 4)</p>
---	--

5.1. Fuses

All fuses on BIOSAFE 1.2/1.2 NF/1.2 BS are located behind the plate holding the control panel.

Fuse no.	Description	Phase L/Zero N	Rate	Order no.
F1	Mains	L	10AT/250V 5x20mm	00841274
F2		N		
F3	Outlet	L	6.3AT/250V 5x20mm	888851096
F4		N		
F5	Light	N	6.3AT/250V 5x20mm	888851096
F6		L		
F7	UV light	N	6.3AT/250V 5x20mm	888851096
F8		L		

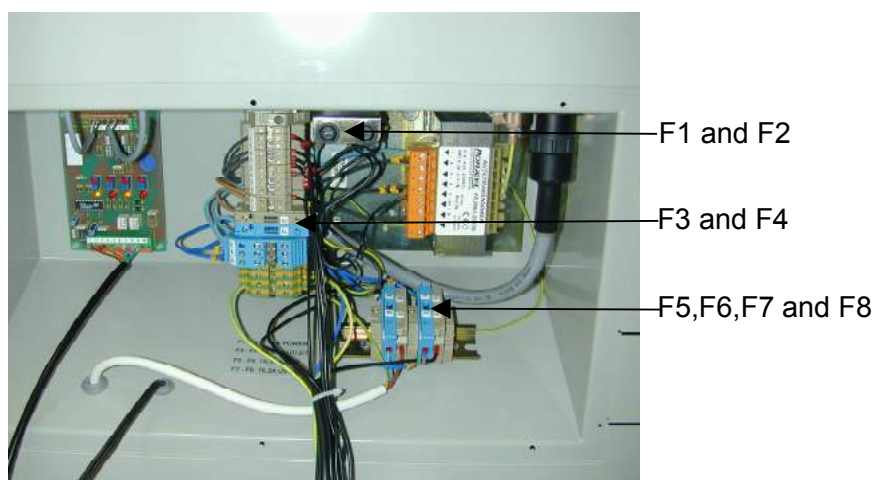

Figure 5.

Equipment required

- Phillips screwdriver.
- Screwdriver for slotted screws.
- Fuses: 10AT or 6,3 AT.

5.1.1. Procedure for replacement

1. Disconnect from mains.
2. Get access to the electric compartment. See section 5.6.
3. Remove the fuse and replace it.
4. Connect to mains and control the relevant function.
5. Assemble in reverse order.

5.2. Fluorescent light tube

The procedures for changing light tube and starter are different on the different types of Biosafes.

Equipment required

- Phillips screwdriver.
- Fluorescent light tube: 36W/83 250 V

5.2.1. Procedure for replacement (Biosafe 1.2/1.2 NF)

1. Disconnect from mains.
2. Open the front window.
3. Take of the protective end caps. See figure 6.



Protective end caps

Figure 6.

4. Replace the tube.
5. Connect to mains and control light function.
6. Assemble in reverse order.

5.2.2. Procedure for replacement (Biosafe 1.2 BS)

1. Disconnect from mains.
2. Dismount the front window by unscrewing the 2 screws in each side of the upper part of the frame.
3. Replace the tube.
4. Connect to mains and control light function.
5. Assemble in reverse order.

5.3. Starter

Equipment required

- Phillips screwdriver
- Starter: FS-U 4-80W

5.3.1.Procedure for replacement (Biosafe 1.2/1.2 NF)

1. Remove the fluorescent light tube. See section.5.2 and 5.2.1.
2. Replace the starter.
3. Connect to mains and control light function.
4. Assemble in reverse order.

5.3.2.Procedure for replacement (Biosafe 1.2 BS)

1. Remove the fluorescent light tube. See section. 5.2 and 5.2.2.
2. Dismount the internal cover using the 2 screws and be aware of the earth connection.
3. Replace the starter in the left fitting by turning it anti clockwise and pull it out.
4. Assemble in reverse order.
5. Connect to mains and control light function.

5.4. Access to internal plenum

Equipment required

- Screwdriver for slotted screws, large and small.
- Hex key 2,5 mm.

5.4.1.Procedure

1. Get access to the electric compartment. See section 5.6.
2. Disconnect the wires for flow sensors, reed relays and light fixture. See figure 7.

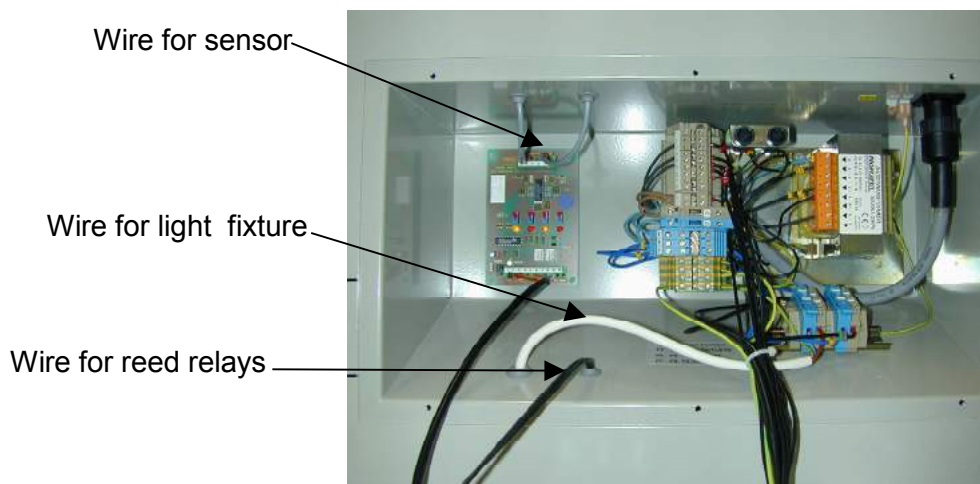



Figure 7.

4. Dismount the front cover. 6 screws. (On Biosafe 1.2 BS the front window has to be lifted in order to get access to 3 lower screws). The front cover is hanging on 2 hooks.
5. Pull the cover out at the lower end and get access to plugs and wires on the rear side of the electrical mounting box. Pull out all wires and disconnect the plug.
6. Take off the front cover.

5.5. Filters

	<p>NOTE The HEPA filter is very delicate. A light touch may damage the filter.</p>
---	---

In order to avoid any possible harm, it is recommended that while changing filters the service technician wears a mask with filter of HEPA quality. (H 13 or better).

The used filters must be placed in special bags for biohazard waste immediately after removal. The special bags should be handled as toxic material and sent for destruction as the normal toxic waste from the laboratory. Contact the responsible for the laboratory.

See instruction manual section 16 concerning safety

Equipment required

- Screwdriver for Phillips screws number 2.
- Wrench size 13-mm.
- Soap and water.
- 2 cable and wire ties.
- Nippers
- Filters see section 8.

The procedure for changing filters is different because the internal plenum is different on BIOSAFE 1.2/1.2 NF versus BIOSAFE 1.2 BS.

Prior to changing filters, disconnect from mains and open the front cover following the description in section 5.4

Check proper function of the front window after reassembling of the front cover.

5.5.1.Procedure for replacement of main filter on BIOSAFE 1.2/1.2 NF

1. Dismount the four bolts in each corner of the filter.
2. Lift the plenum by using the two screws placed inside the cabinet.
3. Replace the filter.
4. Test flow velocity and leakage of filters according to standard.

5.5.2.Procedure for replacement of exhaust filter on BIOSAFE 1.2/1.2 NF

1. Dismount the bolts in each corner of the filter.
2. Remove the pressure chamber.
3. Replace the filter.
4. Test flow velocity and leakage of filters according to standard.

5.5.3. Procedure for replacement of main filter on BIOSAFE 1.2 BS

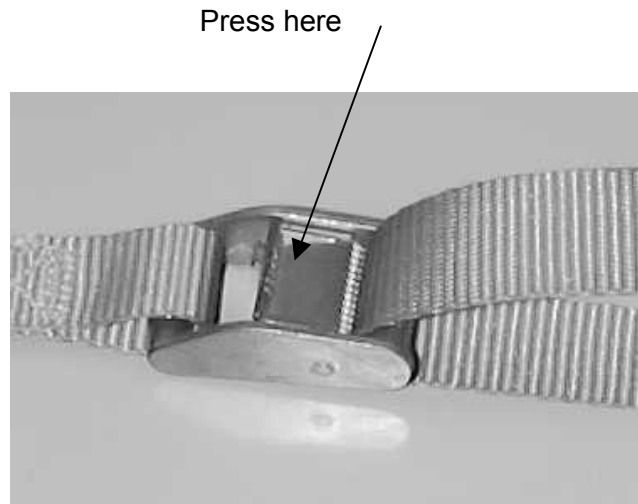

Figure 8.

1. Loosen the belts on both sides by pressing the buckle as illustrated.
2. Fasten the triangular eyes at each of the corners in the iron frame.
3. Guide the belts over the 2 pulleys internally in the gables.
4. Lift the plenum by pulling the belts.
5. Dismount the brackets in front of the filter in order to avoid damaging the gasket.
6. Remove the filter. The filter might stick to the cabinet frame. Pressing with a flat hand under the filter cloth might facilitate removal. In case this is not successful the filter might be removed using a large flat screwdriver or similar. Be careful not to damage the frame. A plastic plate may be used for protection.
7. Install the new filter. The installation is facilitated by application of soap water to the gasket.
8. Lower the plenum.
9. Free the triangle eyes from hooks and belts.
10. Reconnect the belts to the lower hook in front.
11. Tighten the belts and lock the cam buckle by lifting up the pawl.
12. Coil the belts and fasten them with the cable and wire ties.
13. Reinstall the front cover.
14. Test flow velocity and leakage of filters according to standard.

5.5.4. Procedure for replacement of exhaust filter on BIOSAFE 1.2 BS

1. Loosen the screws in front of the filter in order to remove the rails from the frame.
2. Remove the rails and the screws completely using the size 13-mm wrench.
3. Replace the filter without damaging the gasket.

4. Tighten the frame by suspending it while the rails are moved in place.
5. Check from above that the filter is positioned correctly with the gasket positioned equally on all surfaces.
6. Tighten the screw until the gasket has good contact to all sides.
7. Reinstall the front cover.
8. Test flow velocity and leakage of filters according to standard.

5.6. Access to the electric compartment

Remove the plate holding the control panel to gain access for alarm setting, fuses and transformers.

Equipment required

Screwdriver for slotted screws.

5.6.1. Procedure

1. Disconnect from mains.
2. Unscrew the plate holding the control panel.
3. Remove the plate and leave it without stretching the wires. See figure 10.



Figure 10.

5.7. Fans

The cabinet is equipped with a directly driven AC fan designed for long life performance and it is lifetime lubricated. It has built-on capacitors and may be adjusted by changing voltage on the transformers in the electric compartment. See section 7.

Equipment required

- Fan
- Phillips screwdriver
- 13-mm fork wrench.

5.7.1. Procedure for replacement of the fan

1. Open the front cover. See section 5.4
 2. Dismantle the wire from the terminal block on the fan.
 3. Unscrew the fan from plenum.
 4. Exchange the fan.
 5. Reassemble in reverse order.
-

5.8. Controller board PCB

Equipment required

Controller board PCB

5-mm wrench and

Anti-static wristband.

5.8.1. Procedure for exchange of the PCB

- Get access to electric compartment by following the instruction in section 5.6
 - Using anti static wristband connected to the frame when the prints are touched, dismantle all wires and sockets on the print.
 - Unscrew the print.
 - Reassemble in reverse order.
-

5.9. Key switch

Equipment required

- Key switch including keys.
 - 20-mm wrench or fork wrench.
 - Graphite dust (Optionally).
-

5.9.1. Procedure for replacement of key switch

1. Follows to the procedure for replacement of display PCB.
2. Unscrew the key switch and replace it.

6. Electric diagram

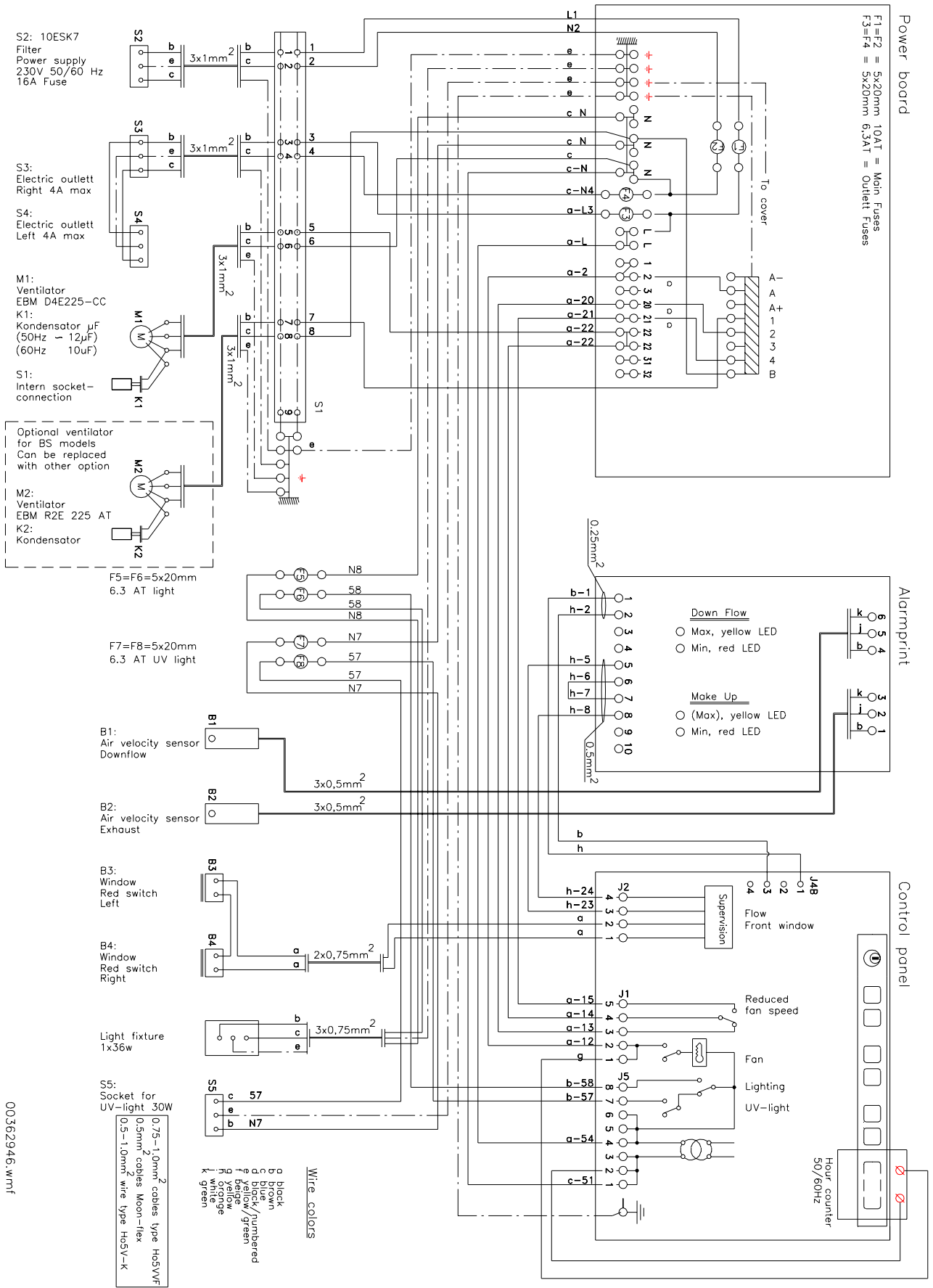

00362946.wmf

7. Setting the auto transformer for the fan

Description

The construction of the autotransformer offers a number of possibilities for voltage supply. The fan may be readjusted to deliver the desired air volume.

Equipment required

- Phillips screwdriver and
- Small screwdriver for slotted screws.

7.1. Procedure for setting air velocity

1. Always disconnect from mains when the transformers are being adjusted.
2. Dismount the plate with the control panel.
3. Adjust the down flow using the black wire (No. 20) on the autotransformer (ASU 96....) until the average air velocity is measured according to section 2.4.
4. Find the black wire (No. 21) for reduced velocity and place it in an appropriate terminal in order to obtain a desired air velocity under the main filter. (50-75 % of normal velocity).

		Output.						
		Normal fan speed Black wire from terminal 20 on terminal block.						
		Reduced fan speed Black wire from terminal 21 on terminal block.						
		Zero: B						
		A-	A	A+	1	2	3	4
Input 230V. Black wire from terminal 2 on terminal block. Zero: B	A-		216	203	168	141	115	88
	A	243		215	178	150	122	94
	A+	260	245		190	160	130	100

8. Spare parts

See Instruction Manual regarding filters.

Spare parts	
Item	Catalogue number
Manual 1.2/1.2 BS	807229 / 807235
Fan	822458
Transformer	847225
Controller board	849112
Alarm module PCB	849117
Flow sensor	849118
Key switch	841004
IEC connector filter	88856013
Fluorescent light tube	844027
Starter	844086
Fuse 10AT	841274
Fuse 6,3AT	88851096
Front cover GS/NF/BS	58250000 / 58250500 / 58250152
Front window 1.2/1.2 BS	58250002 / 58250154
Gasket (BS model only)	2,5 m x 832441
Set of belts (BS model only)	2 x 973128 + 2 x 973129
Tabletop	970225
Silicone (tube)	88831212

Accessories/Options	
Item	Catalogue number
Anti blow-back valve Ø200	80050035
Gas valve left side	58251016
Carbon-dioxide valve left side	58251017
Vacuum valve left side	58251018
UV-light placed on night cover	58251011
Night cover	58251010
BS exhaust filter	80050038
Flock filter for fan protection	58251020
Minihelic – Differential pressure drop for main filter	80130001
Support stand (height 76-80 cm)	58251000
Support stand (height 88-92 cm)	58252000
Support base for table installation	58250003
Mains voltage 115V	57240257
Mains frequency 60 Hz	57240258