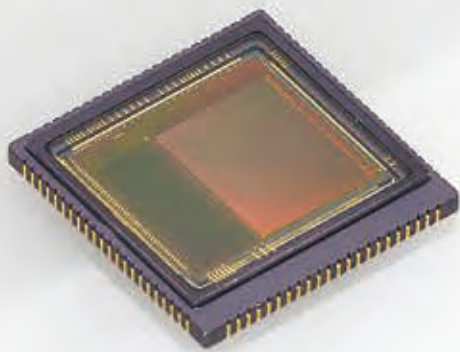
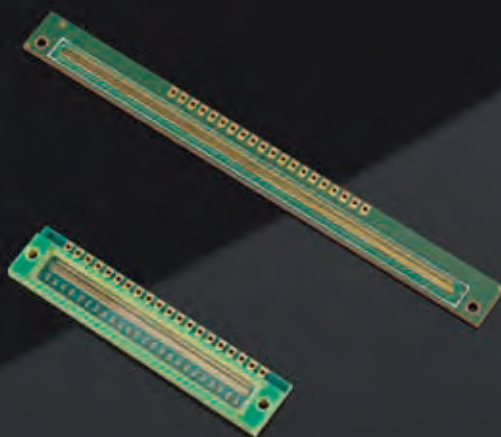

Image Sensors

Various types of image sensors covering a wide spectral response range for photometry



■ CMOS area image sensor
S13101



■ CMOS linear image sensors for industry
S14416-06, S14416-12



■ InGaAs area image sensor
G13393-0909W

Image sensors

Various types of image sensors covering a wide spectral response range for photometry

Hamamatsu develops and produces advanced image sensors for measurement applications in wide spectral and energy ranges including infrared, visible, ultraviolet, vacuum ultraviolet, soft X-rays and hard X-rays. We provide a full lineup of image sensors to precisely match the wavelength of interest and application. Hamamatsu complies with customer needs such as for different window materials, filters or fiber couplings. We also offer easy-to-use driver circuits for device evaluation and sensor/driver modules for OEM applications as well as multichannel detector heads.

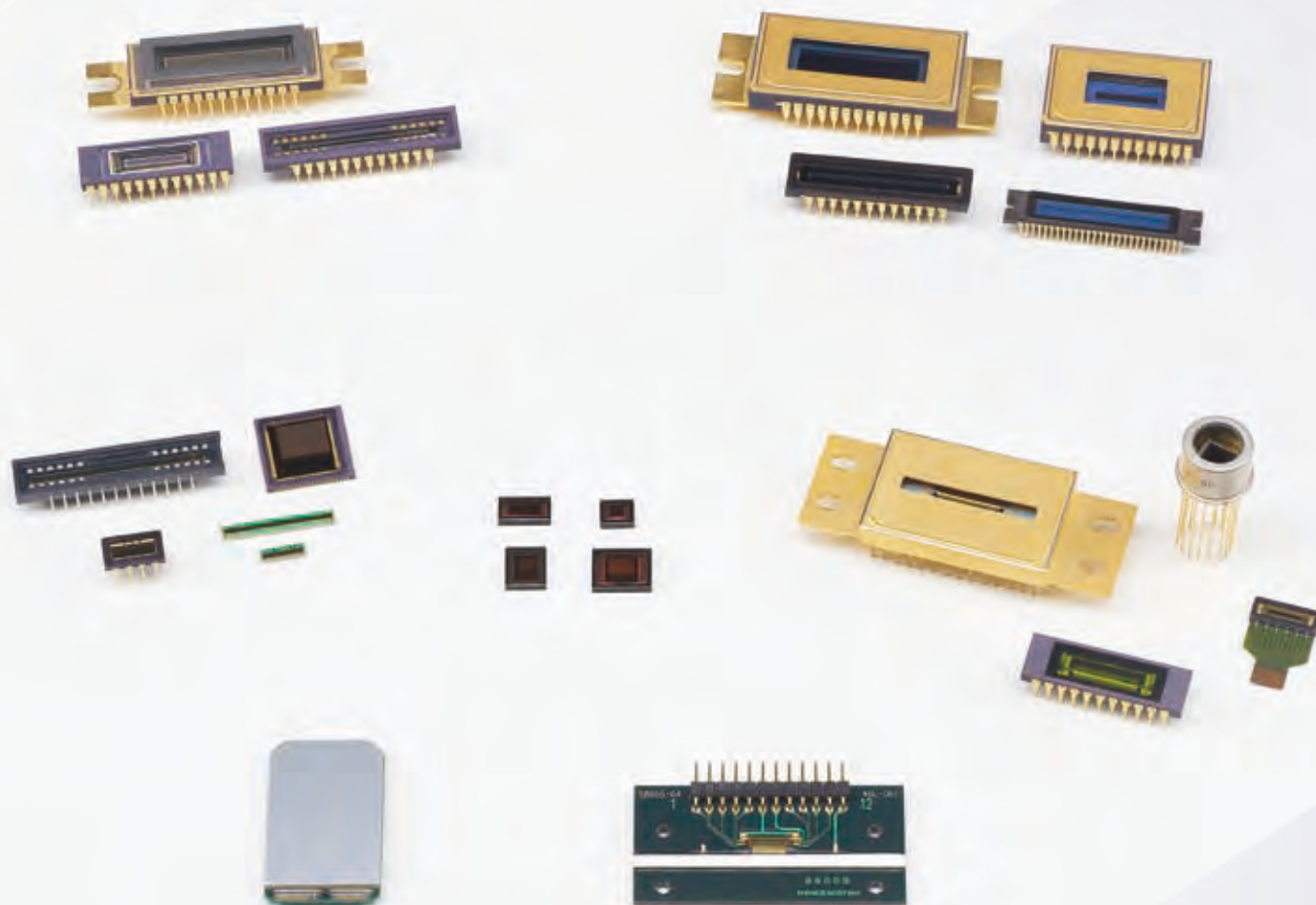

Contents

- Lineup of image sensors 3
- Image sensor technology of Hamamatsu 7
- Area image sensors 9
 - Back-thinned type CCD area image sensors 9
 - Front-illuminated type CCD area image sensors 14
 - CMOS area image sensors 15
- Linear image sensors 16
 - CMOS linear image sensors for spectrophotometry ... 17
 - CCD linear image sensors for spectrophotometry 20
 - NMOS linear image sensors for spectrophotometry ... 21
 - CCD linear image sensors for industry 23
 - CMOS linear image sensors for industry 24
- Photodiode arrays with amplifier 27
- Distance image sensors 28
- Image sensors for near infrared region 29
- X-ray image sensors 33
- X-ray flat panel sensors 36
- Related products for image sensors 38
 - Multichannel detector heads 38
 - Driver circuits for image sensors 41

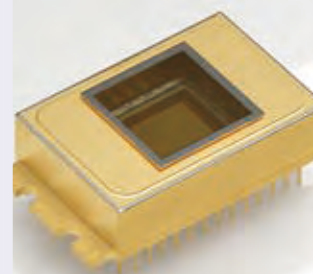
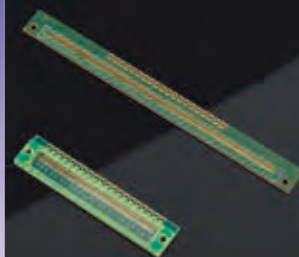
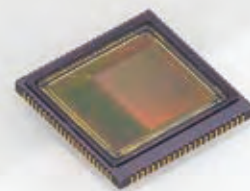

Lineup of image sensors

Product name	Feature	Lineup	Page
◆ Area image sensors			
Back-thinned type CCD area image sensors	CCD area image sensors delivering high quantum efficiency from visible to VUV region	<ul style="list-style-type: none"> For spectrophotometry For spectrophotometry (High resolution type) For spectrophotometry (Low etaloning type) For spectrophotometry (Large full well type) For ICP spectrophotometry For scientific measurement Fully-depleted type 	9 to 13
Front-illuminated type CCD area image sensors	Low dark current and low noise CCD area image sensors suitable for scientific measurement instruments	<ul style="list-style-type: none"> For spectrophotometry For scientific measurement 	14, 15
CMOS area image sensors	APS type CMOS area image sensors with high sensitivity in the near infrared region	<ul style="list-style-type: none"> SXGA format VGA format 	15

◆ **Linear image sensors** e.g. hyperspectral remote sensing images

CMOS linear image sensors for spectrophotometry	CMOS linear image sensors suitable for spectrophotometry	<ul style="list-style-type: none"> High sensitivity type Variable integration time type Standard type 	17 to 19
CCD linear image sensors for spectrophotometry	The back-thinned type CCD linear image sensors feature high UV sensitivity and an internal electronic shutter. The front-illuminated type offers high sensitivity in the ultraviolet region (200 nm) nearly equal to back-thinned CCD.	<ul style="list-style-type: none"> Back-thinned type Front-illuminated type 	20, 21
NMOS linear image sensors for spectrophotometry	Image sensors with high UV sensitivity and excellent output linearity, making them ideal for precision photometry	<ul style="list-style-type: none"> Current output type Current output type (Infrared enhanced type) Voltage output type 	21, 22
CCD linear image sensors for industry	CCD linear image sensors suitable for industry	<ul style="list-style-type: none"> TDI-CCD image sensor (Back-illuminated type) Front-illuminated type 	23, 24
CMOS linear image sensors for industry	CMOS linear image sensors incorporate a timing circuit and signal processing amplifiers integrated on the same chip, and operate from simple input pulses and a single power supply. Thus the external circuit can be simplified.	<ul style="list-style-type: none"> Resin-sealed type package High-speed readout type High sensitivity type Digital output type With RGB color filters 	24 to 26

◆ **Photodiode arrays with amplifier**

Photodiode arrays with amplifier	Sensors combining a Si photodiode array and a signal processing IC. A long and narrow image sensor can also be configured by arranging multiple arrays in a row.	<ul style="list-style-type: none"> Long and narrow area type 	27
----------------------------------	--	---	----

◆ **Distance image sensors**

Distance image sensors	These distance image sensors are designed to measure the distance to an object by TOF method. When used in combination with a pulse modulated light source, these sensors output phase difference information on the timing that the light is emitted and received.	<ul style="list-style-type: none"> Distance linear image sensor Distance area image sensor 	28
------------------------	---	--	----

◆ **Image sensors for near infrared region**

InGaAs linear image sensors	Image sensors for near infrared region. Built-in CMOS IC allows easy operation.	<ul style="list-style-type: none"> For NIR spectrometry High-speed type 	30, 31
InGaAs area image sensors		<ul style="list-style-type: none"> For thermal imaging monitor For near infrared image detection 	32

Product name	Feature	Lineup	Page
--------------	---------	--------	------

◆ X-ray image sensors

<p>CCD area image sensors CMOS area image sensors Photodiode arrays with amplifier</p>	<p>Image sensors and photodiode arrays deliver high quality X-ray images by coupling FOS (fiber optic plate coated with X-ray scintillator) and phosphor sheet.</p>	<ul style="list-style-type: none"> • CCD/CMOS area image sensors for X-ray radiography • TDI-CCD area image sensors • Photodiode arrays with amplifier for non-destructive inspection 	34, 35
--	---	--	--------

◆ X-ray flat panel sensors

X-ray flat panel sensors	Digital X-ray image sensors developed for real-time X-ray imaging applications requiring high sensitivity and high image quality	<ul style="list-style-type: none"> • For radiography (rotational type) • For radiography (biochemical imaging) • General type (off-line) • Low noise type 	36, 37
--------------------------	--	---	--------

◆ Related products for image sensors

Multichannel detector heads	These products house in a heat dissipating case a driver circuit supporting Hamamatsu's main image sensors.	<ul style="list-style-type: none"> • For front-illuminated type CCD area image sensors • For back-thinned type CCD area image sensors • For NMOS linear image sensors • For InGaAs linear image sensors • For InGaAs area image sensors 	38 to 40
Driver circuits for image sensors	Driver circuits designed for various image sensors	<ul style="list-style-type: none"> • For CCD image sensors • For NMOS linear image sensors (Current output type) • For CMOS linear image sensors • For InGaAs linear image sensors 	41, 42

◆ Example of detectable light level

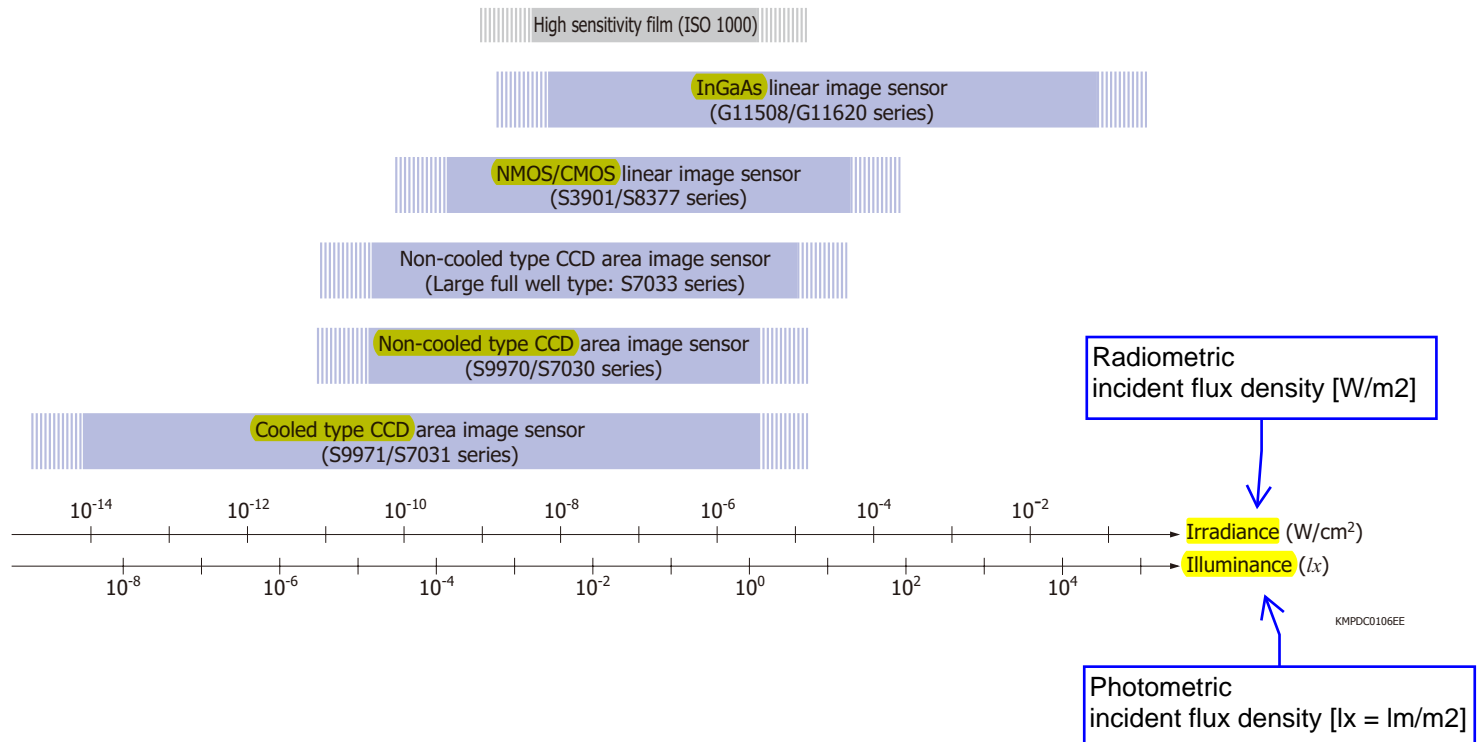



Hamamatsu Photonics uses its original silicon/compound semiconductor process technology to manufacture image sensors that cover a wide energy and spectral range from 2.6 μm near infrared region to visible, UV, vacuum UV (VUV), soft X-ray, and even hard X-ray region. In addition, we also provide module products designed to work as driver circuits for various image sensors.

Si process technology

- CCD
- CMOS



Compound semiconductor process technology

- InGaAs



MEMS technology

- Back-illuminated type
- Three-dimensional mounting [fine pitch bump bonding, TSV (through silicon via)]

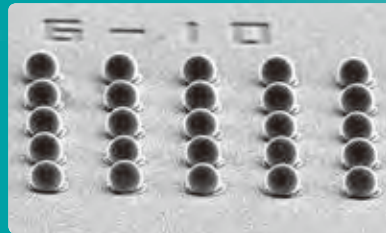

Spectral response

[**CCD area** image sensor (without window)]

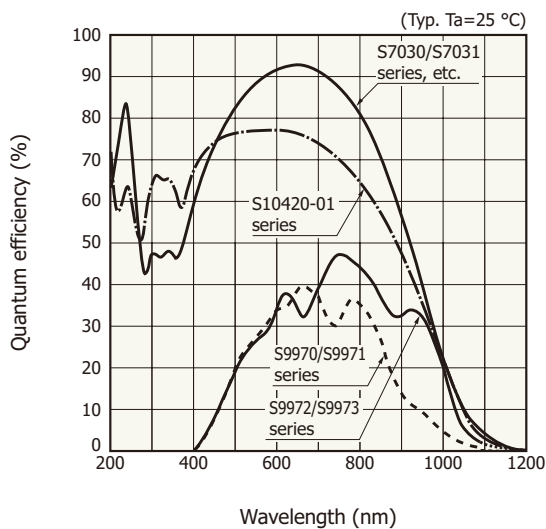

[**CMOS linear** image sensor]

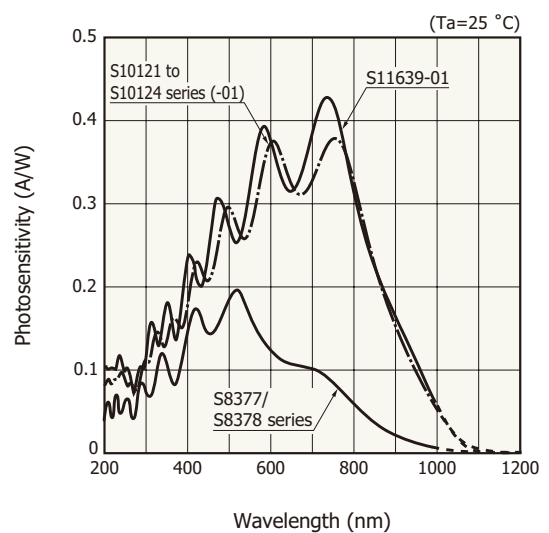

Example of detectable energy level and spectral response range

Hamamatsu develops and produces image sensors that cover a spectral range from 2.6 μm near infrared region to visible, UV, vacuum UV (VUV), soft X-ray, and even hard X-ray region of hundred and several tens of keV.

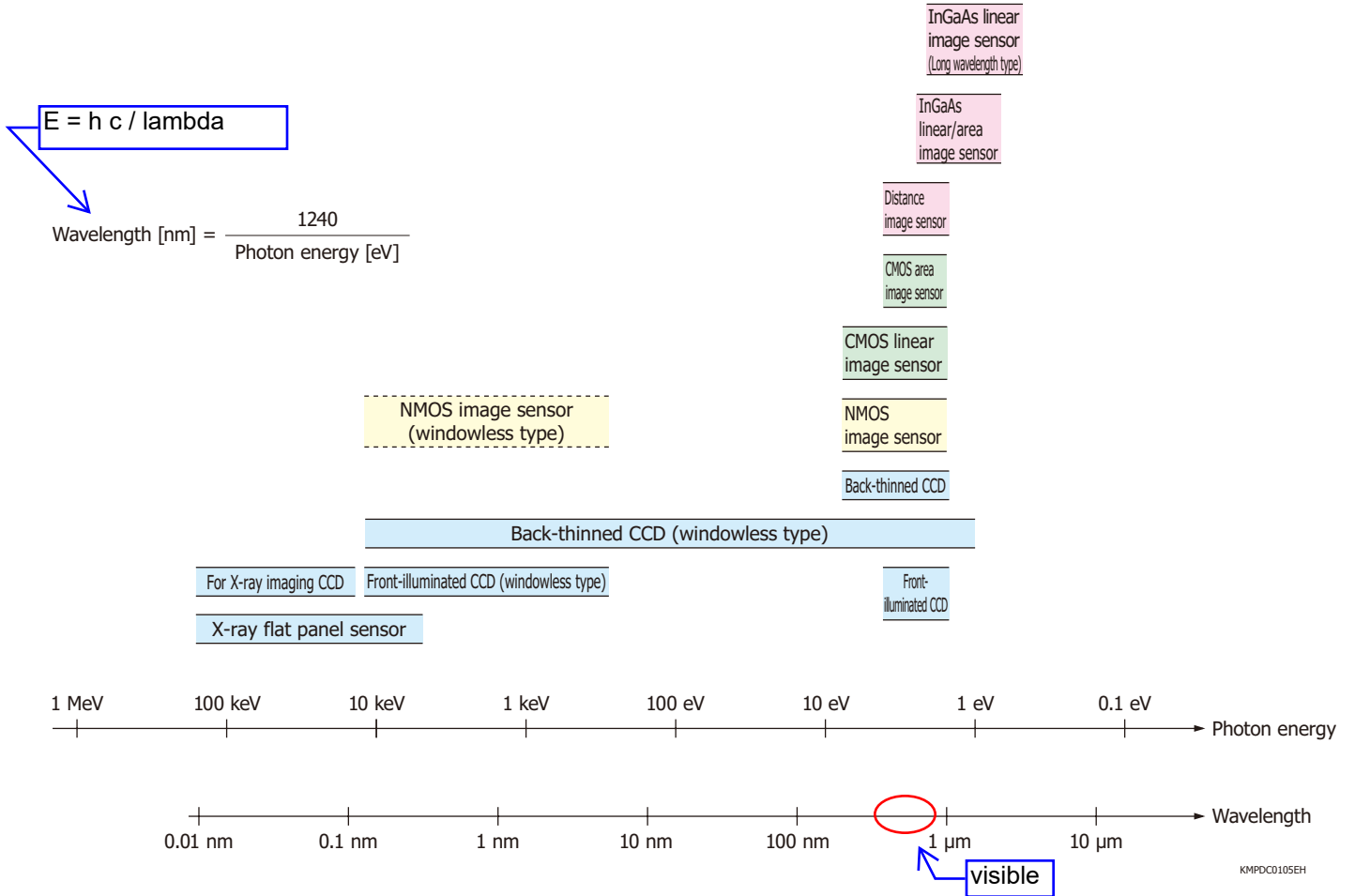

Note: If using an NMOS linear image sensor (windowless type) for X-ray direct detection, please consult our sales office regarding usage conditions.

[NMOS linear image sensor]

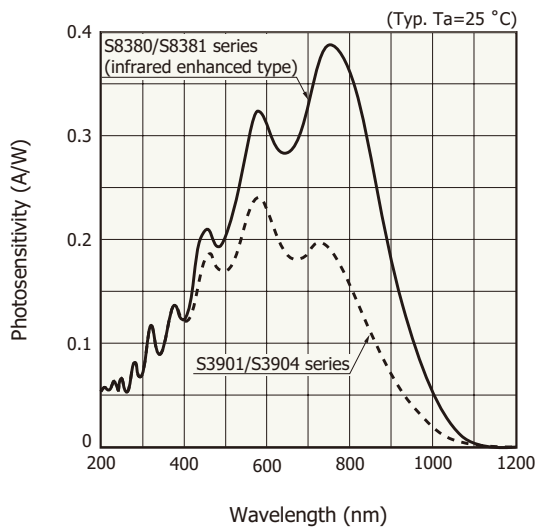

[InGaAs linear image sensor]

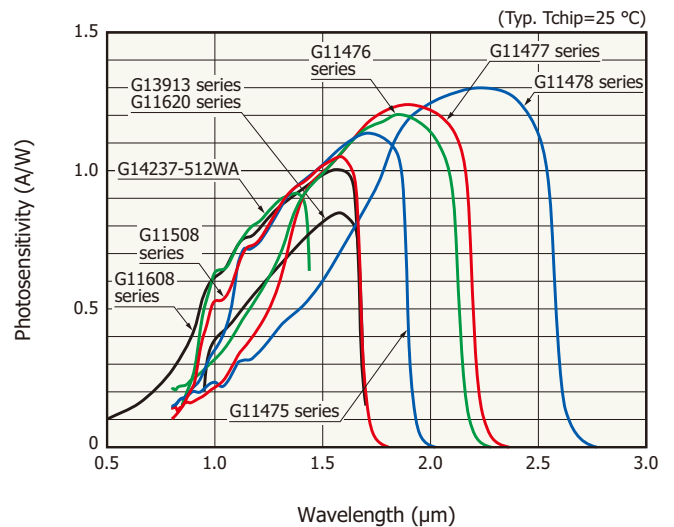

Image sensor technology of Hamamatsu

CMOS technology

Hamamatsu produces CMOS image sensors that use its uniquely developed analog CMOS technology at their cores for applications mainly aimed at **measuring equipment** such as analytical instruments and medical equipment. With analog and digital features that meet market needs built into the same chip as the sensor, systems can be designed with high performance, multi-functionality, and low cost.

- Supports photosensitive areas of various shapes (silicon/compound semiconductor, one- and two-dimensional array, large area)
- Highly functional (high-speed or partial readout, built-in A/D converter, global shutter, etc.)
- Customization for specific applications

Example of high functionality based on CMOS technology

Distance image sensor

This image sensor can detect distance information for the target object using the TOF (time-of-flight) method. A distance measurement system can be configured by combining a pulse-modulated light source and a signal processing section.

Example of distance measurement diagram

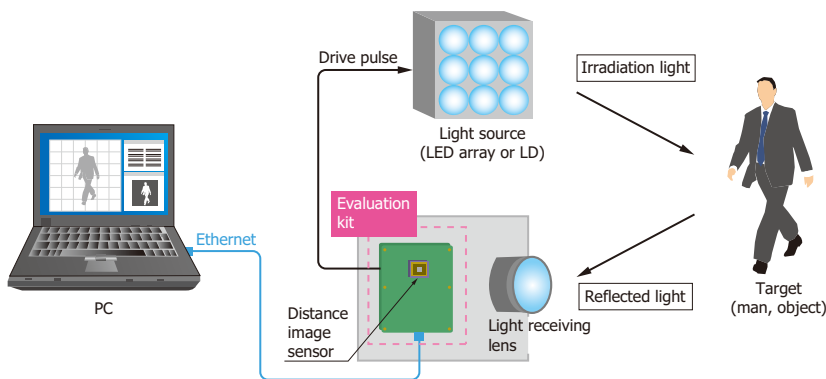

KMPDC0417EB

Near infrared-enhanced CMOS area image sensor

Our unique photosensitive area technology provides high sensitivity in the near infrared region.

Spectral response (typical example)

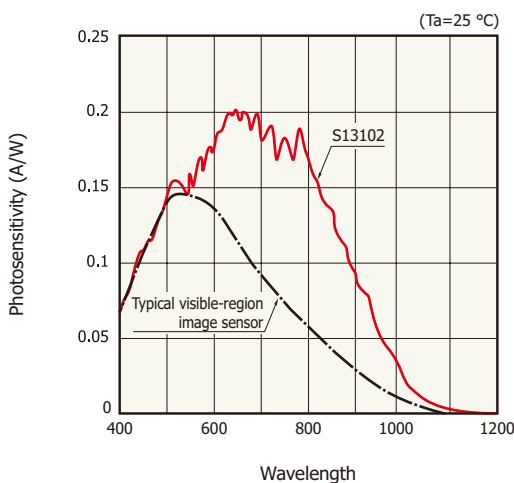

KMPDB0489EA

Imaging example of finger veins using near infrared-enhanced CMOS area image sensor

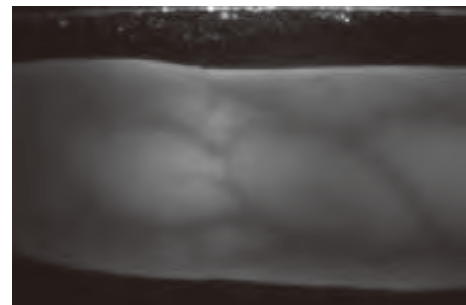

Compact thin COB (chip on board) package technology

Small mount area can be achieved by mounting the CMOS image sensor chip on a compact thin COB package that is about the same size. In a COB package, the chip is sealed in a resin mold, which provides high reliability and ease of use. CMOS image sensors that employ this technology can be used in a wide range of applications. They contribute to cost reduction, size reduction, and high-volume production of equipment. This technology makes our single 3.3 V power supply operated, low power consumption, high sensitivity CMOS image sensors even more easier to use.

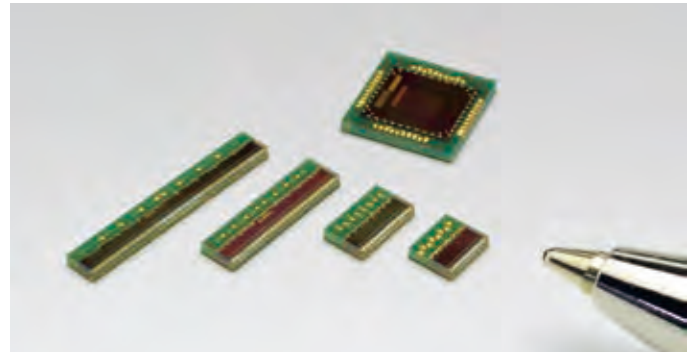

Hybrid technology (Three-dimensional mounting)

InGaAs image sensors for near infrared region employ a hybrid structure in which the photodiode array used as the photosensitive area and the CMOS signal processing circuit are implemented in separate chips and mounted in three dimensions using bumps. This is used when it is difficult to make the photosensitive area and the signal processing circuit monolithic. Moreover, this construction is advantageous in that the shape of the photosensitive area, spectral response, and the like can easily be modified.

Schematic diagram of InGaAs area image sensor using fine-pitch bumps

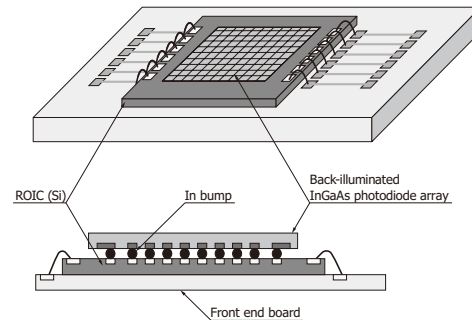

KMIRC0036EB

Boro-Phospho-Silicate Glass (dielectric cover)

Back-thinned technology

In general, CCDs are designed to receive light from the front side where circuit patterns are formed. This type of CCD is called the **front-illuminated CCD**. The light input surface of front-illuminated CCDs is formed on the front surface of the silicon substrate where a BPSG film, poly-silicon electrodes, and gate oxide film are deposited. Light entering the front surface is largely reflected away and absorbed by those components. The quantum **efficiency is therefore limited to approx. 40% at the highest** in the visible region, and there is no sensitivity in the ultraviolet region.

Back-thinned CCDs were developed to solve such problems. Back-thinned CCDs also have a BPSG film, poly-silicon electrodes, and gate oxide film on the surface of the silicon substrate, but they receive light from the backside of the silicon substrate. Because of this structure, back-thinned CCDs deliver **high quantum efficiency over a wide spectral range**. Besides having high sensitivity and low noise which are the intrinsic features of CCDs, back-thinned CCDs are also sensitive to electron beams, soft X-rays, ultraviolet, visible, and near infrared region.

Schematic of CCDs

[Back-thinned type]

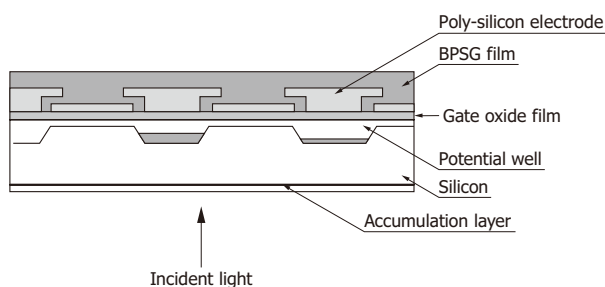

KMPDC0180EB

[Front-illuminated type]

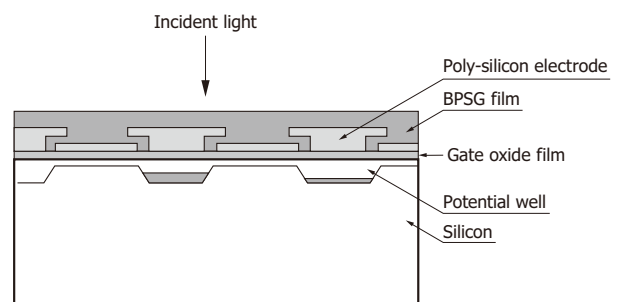

KMPDC0179EB

Area image sensors

Hamamatsu CCD area image sensors have extremely low noise and can acquire image signals with high S/N. Hamamatsu CCD area image sensors use an FFT-CCD that achieves a 100% fill factor and collects light with zero loss, making them ideal for high precision measurement such as spectrophotometry. These CCD area image sensors are available in a front-illuminated type or a back-thinned type. The front-illuminated type detects light from the front side where circuit patterns are formed, while the back-thinned type detects light from the rear of the Si substrate. Both types are available in various pixel sizes and pixel formats allowing you to select the device that best meets your applications. The rear of the back-thinned type is thinned to form an ideal photosensitive surface delivering higher quantum efficiency over a wide spectral range.

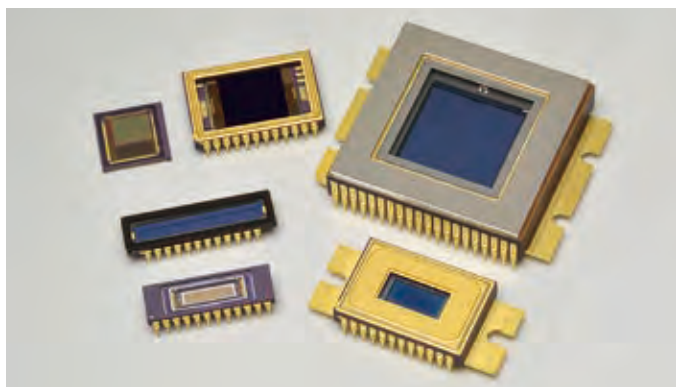



CMOS area image sensors are APS (active pixel sensor) type with high sensitivity in the near infrared region.

Back-thinned type CCD area image sensors

Back-thinned type CCD area image sensors deliver high quantum efficiency (90% or more at the peak wavelength) in spectral range up to VUV region, and have great stability in sensitivity for UV irradiation. Moreover these also feature low noise and are therefore ideal for low-light-level detection.

For spectrophotometry

Achieving high quantum efficiency (at peak 90% min.) and suitable for high accuracy spectrophotometry

Type no.	Pixel size [μm (H) \times μm (V)]	Number of effective pixels	Line rate* ¹ (lines/s)	Cooling* ²	Photo	Dedicated driver circuit* ³ (P.38)
S7030-0906	24 \times 24	512 \times 58	418	Non-cooled		C7040
S7030-0907		512 \times 122	316			
S7030-1006		1024 \times 58	213			
S7030-1007		1024 \times 122	160			
S7031-0906S		512 \times 58	418	One-stage TE-cooled		C7041
S7031-0907S		512 \times 122	316			
S7031-1006S		1024 \times 58	213			
S7031-1007S		1024 \times 122	160			

*1: Full line binning (typ.)



*2: Two-stage TE-cooled type (S7032-1006/-1007) is available upon request (made-to-order product).

*3: Sold separately

Note: Windowless type is available upon request.

For spectrophotometry (High resolution type)

CCD area image sensors having superior low noise performance. Low noise type [S10140/S10141 series (-01)] and high-speed type (S13240/S13241 series) are available.

Type no.	Pixel size [μm (H) \times μm (V)]	Number of effective pixels	Line rate* ⁴ (lines/s)	Cooling* ⁵	Photo	Dedicated driver circuit* ⁶ (P.39)	
S10140-1107-01	12 \times 12	2048 \times 122	107	Non-cooled		C10150-01	
S10140-1108-01		2048 \times 250	80				
S10140-1109-01		2048 \times 506	40				
S13240-1107		2048 \times 122	921			-	
S13240-1108		2048 \times 250	539				
S13240-1109		2048 \times 506	203				
S10141-1107S-01		12 \times 12	2048 \times 122	107	One-stage TE-cooled		C10151-01
S10141-1108S-01			2048 \times 250	80			
S10141-1109S-01			2048 \times 506	40			
S13241-1107S	2048 \times 122		921	-			
S13241-1108S	2048 \times 250		539				
S13241-1109S	2048 \times 506		203				

*4: Full line binning (typ.)















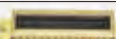

*5: Two-stage TE-cooled type [S10142 series (-01)] is available upon request (made-to-order product).

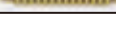
*6: Sold separately

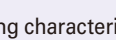
Note: Windowless type is available upon request.

For spectrophotometry (Low etaloning type)

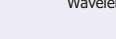
Two types consisting of a low noise type (S10420/S14650/S14651 series, S11850-1106) and high-speed type (S11071/S14660/S14661 series, S11851-1106) are available with improved etaloning characteristics. The S11850/S11851-1106 and S14651/S14661 series have a thermoelectric cooler within the package to minimize variations in the chip temperature during operation.

Type no.	Pixel size [μm (H) \times μm (V)]	Number of effective pixels	Line rate*1 (lines/s)	Cooling	Photo	Dedicated driver circuit*2 (P.41)
S10420-1004-01	14 \times 14	1024 \times 16	221	Non-cooled		C11287
S10420-1006-01		1024 \times 64	189			
S10420-1104-01		2048 \times 16	116			
S10420-1106-01*3		2048 \times 64	106			
S14650-1024		1024 \times 192	95			-
S14650-2048		2048 \times 192	68			
S11071-1004		1024 \times 16	1777			C11288
S11071-1006		1024 \times 64	751			
S11071-1104		2048 \times 16	1303			
S11071-1106		2048 \times 64	651			
S14660-1024		1024 \times 192	296			-
S14660-2048		2048 \times 192	148			
S11850-1106		2048 \times 64	106			C11860
S14651-1024		1024 \times 192	95			C11860
S14651-2048		2048 \times 192	68			
S11851-1106		2048 \times 64	651			-
S14661-1024	1024 \times 192	296		-		
S14661-2048	2048 \times 192	148				

*1: Full line binning (typ.)

*2: Sold separately

*3: Ultra-violet enhanced type (S10420-1106NU-01, S10420-1106NW-01) are available.

Note: Windowless type is available upon request.

Improved etaloning characteristic

Etaloning is an interference phenomenon that occurs when the light incident on a CCD repeatedly reflects between the front and back surfaces of the CCD while being attenuated, and causes alternately high and low sensitivity. When long-wavelength light enters a back-thinned CCD, etaloning occurs due to the relationship between the silicon substrate thickness and the absorption length. These back-thinned CCDs have achieved a significant improvement on etaloning by using a unique structure that is unlikely to cause interference.



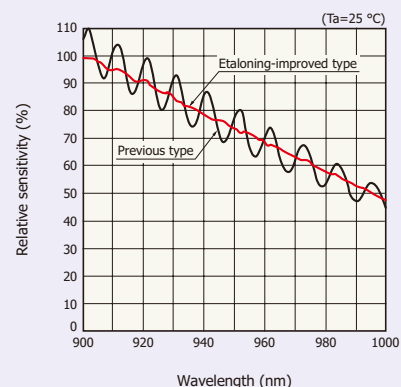

● Etaloning characteristic (typical example)



KMPDB0284EB

For spectrophotometry (Large full well type)

Wide dynamic range is achieved.



Type no.	Pixel size [μm (H) \times μm (V)]	Number of effective pixels	Line rate* ⁴ (lines/s)	Cooling	Photo	Dedicated driver circuit* ⁵ (P.39)
S7033-0907	24 \times 24	512 \times 122	316	Non-cooled		C7043
S7033-1007		1024 \times 122	160			
S7034-0907S		512 \times 122	316	One-stage TE-cooled		C7044
S7034-1007S		1024 \times 122	160			

*4: Full line binning (typ.) *5: Sold separately

Note: Windowless type is available upon request.

For ICP spectrophotometry

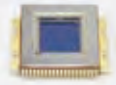
These CCD area image sensors have a back-thinned structure that enables high sensitivity in the UV to visible region as well as wide dynamic range, low dark current, and an anti-blooming function.







Type no.	Pixel size [μm (H) \times μm (V)]	Number of effective pixels	Frame rate* ⁶ (frames/s)	Cooling	Photo	Dedicated driver circuit
S12071	24 \times 24	1024 \times 1024	Tap A: 0.1 Tap B: 1.5	One-stage TE-cooled		-
S12101	12 \times 12	2048 \times 2048	Tap A: 0.02 Tap B: 2.4			

*6: Area scanning (typ.)

Note: Windowless type is available upon request.

For scientific measurement

Selectable from a lineup covering various types of high performance back-thinned CCD area image sensors such as high-speed readout type and low noise type

Type no.	Pixel size [μm (H) \times μm (V)]	Number of effective pixels	Frame rate* ⁷ (frames/s)	Cooling	Photo	Dedicated driver circuit* ⁸ (P.39)
S7170-0909	24 \times 24	512 \times 512	0.9	Non-cooled* ⁹		C7180
S7171-0909-01				One-stage* ⁹ TE-cooled		C7181
S9037-0902		512 \times 4	16300	Non-cooled		-
S9037-1002		1024 \times 4	8100			
S9038-0902S		512 \times 4	16300	One-stage TE-cooled		-
S9038-1002S		1024 \times 4	8100			

*7: Area scanning (typ.) excluding full line binning (max.) for S9037/S9038 series

*8: Sold separately *9: Two-stage TE-cooled type (S7172-0909) is available upon request (made-to-order product).

Note: Windowless type is available upon request.

Fully-depleted type

The S10747-0909 is a back-illuminated CCD area image sensor that delivers drastically improved near-infrared sensitivity by the widened depletion layer.

Type no.	Pixel size [μm (H) \times μm (V)]	Number of effective pixels	Thickness of depletion layer (μm)	Cooling	Photo	Dedicated driver circuit
S10747-0909	24 \times 24	512 \times 512	200	Non-cooled		–

Structure of fully-depleted back-illuminated CCD

In ordinary back-thinned CCDs, the silicon substrate is only a few dozen microns thick. This means that near-infrared light is more likely to pass through the substrate (see Figure 1), thus resulting in a loss of quantum efficiency in infrared region. Thickening the silicon substrate increases the quantum efficiency in the near-infrared region but also makes the resolution worse since the generated charges diffuse into the neutral region unless a bias voltage is applied (see Figure 2). Fully-depleted back-illuminated CCDs use a thick silicon substrate that has no neutral region when a bias voltage is applied and therefore deliver high quantum efficiency in the near-infrared region while maintaining a good resolution (see Figure 3). One drawback, however, is that the dark current becomes large so that these devices must usually be cooled to about $-70\text{ }^{\circ}\text{C}$ during use.

Figure 1 Back-thinned CCD

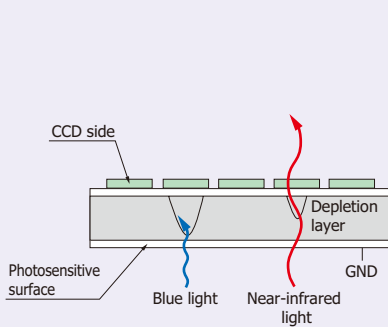

Figure 2 When no bias voltage is applied to thick silicon

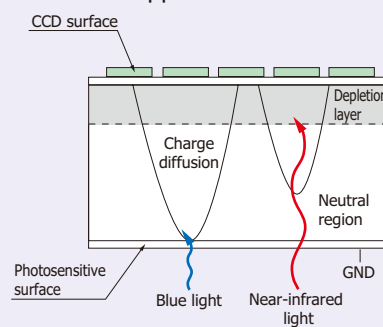
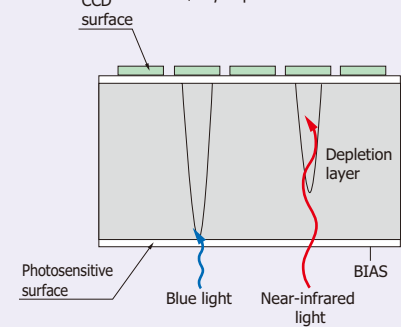
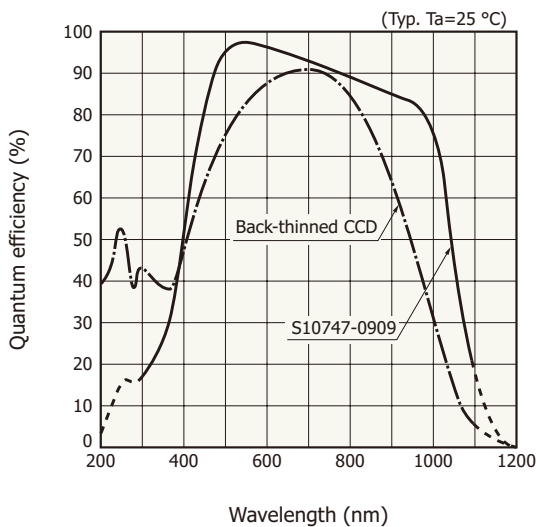

Figure 3 When a bias voltage is applied to thick silicon (fully-depleted back-illuminated CCD)



KMPDC0332EA

Spectral response (without window)



KMPDB0313EA

Front-illuminated type CCD area image sensors

Front-illuminated type CCD area image sensors are low dark current and low noise CCDs ideal for scientific measurement instruments.

For spectrophotometry

CCD area image sensors specifically designed for spectrophotometry. By using the binning operation, they can be used as a linear image sensor having a long aperture in the direction of the device length.

Type no.	Pixel size [μm (H) \times μm (V)]	Number of effective pixels	Line rate* ¹ (lines/s)	Cooling	Photo	Dedicated driver circuit* ² (P.38)
S9970-0906	24 \times 24	512 \times 60	169	Non-cooled		C7020
S9970-1006		1024 \times 60	86			
S9970-1007		1024 \times 124	66			
S9970-1008		1024 \times 252	34			
S9971-0906		512 \times 60	169	One-stage TE-cooled		C7021
S9971-1006		1024 \times 60	86			
S9971-1007		1024 \times 124	66			
S9971-1008		1024 \times 252	34			
S9972-1007* ³	1024 \times 124	66	Non-cooled		C7020-02	
S9972-1008* ³	1024 \times 252	34				
S9973-1007* ³	1024 \times 124	66	One-stage TE-cooled		C7021-02	
S9973-1008* ³	1024 \times 252	34			C7025-02	

*1: Full line binning (typ.)





*2: Sold separately

*3: Infrared enhanced type

Note: In case of ceramic package CCD (S9970/S9972 series), windowless, UV coat, and FOP coupling are available upon request (made-to-order product).

For scientific measurement

These are CCD area image sensors that deliver high accuracy measurement. The image sensors with 512×512 and 1024×1024 effective pixels are ideal for acquiring two-dimensional images.

Type no.	Pixel size [μm (H) \times μm (V)]	Number of effective pixels	Frame rate* ¹ (frames/s)	Cooling	Package	Photo	Dedicated driver circuit
S9736-01	24 \times 24	512 \times 512	0.3	Non-cooled	Ceramic DIP		-
S9736-03					Plate type		
S9737-01	12 \times 12	1024 \times 1024	0.09		Ceramic DIP		
S9737-03					Plate type		
S9979	48 \times 48	1536 \times 128	9		Ceramic DIP		





*1: Area scanning (typ.)

Note: In case of ceramic package CCD (S9736-01, S9737-01, S9979), windowless, UV coat, and FOP coupling are available upon request (made-to-order product).

CMOS area image sensors

note: APS also means Adv.Photo.System for camera manufacturers

These are APS (active pixel sensor) type CMOS area image sensors with high sensitivity in the near infrared region. They include a timing generator, a bias generator, an amplifier and an A/D converter, and offer all-digital I/O for easy handling.

Type no.	Pixel size [μm (H) \times μm (V)]	Number of effective pixels	Frame rate max. (frames/s)	Package	Photo	Dedicated driver circuit
S13101	7.4 \times 7.4	1280 \times 1024	146	Ceramic		-
S13102		640 \times 480	78			
S13499	9.9 \times 9.9	659 \times 494	75	Ceramic		-
NEW S14250	50 \times 50	30 \times 30	344			

Spectral response (S13101, S13102, typical example)

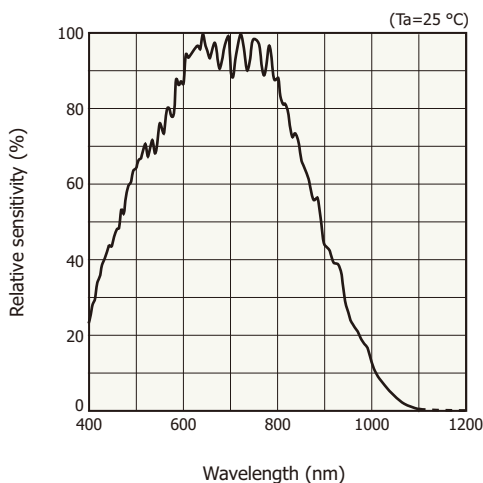

Block diagram (S13101)

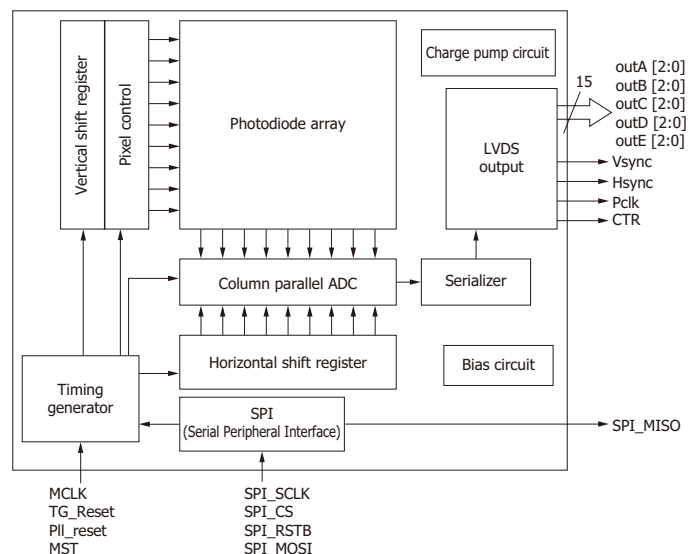

Linear image sensors

CMOS linear image sensors are widely used in spectrophotometry and industrial equipment. Innovations in CMOS technology have increased the integrated circuit density making CMOS linear image sensors easier to use and available in a compact package and at a reasonable cost. All essential signal processing circuits are formed on the sensor chip.

Back-thinned type CCD linear image sensors have high UV sensitivity ideal for spectrophotometry. They also have low noise, low dark current and wide dynamic range, allowing low-light-level detection by making the integration time longer.

Front-illuminated type CCD linear image sensors offer high sensitivity in the ultraviolet region nearly equal to back-thinned type.

NMOS linear image sensors feature large charge accumulation and high output linearity making them ideal for scientific measurement instruments that require high accuracy. Output charge can be converted into voltage by an external readout circuit. Both CMOS and NMOS linear image sensors are capable of handling a larger charge than CCD image sensors and so can be used at higher light levels.

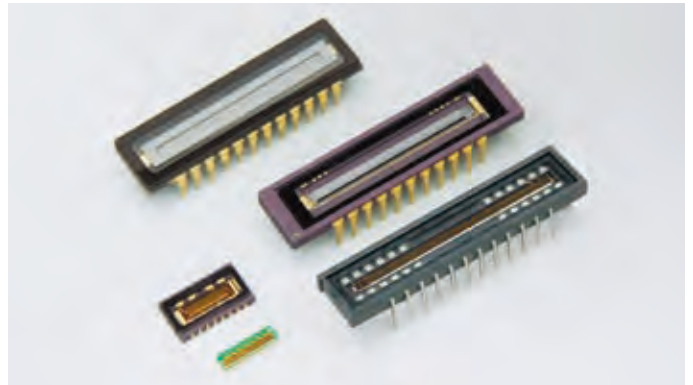

Equivalent circuits

[CMOS linear image sensor (S9227-03)]

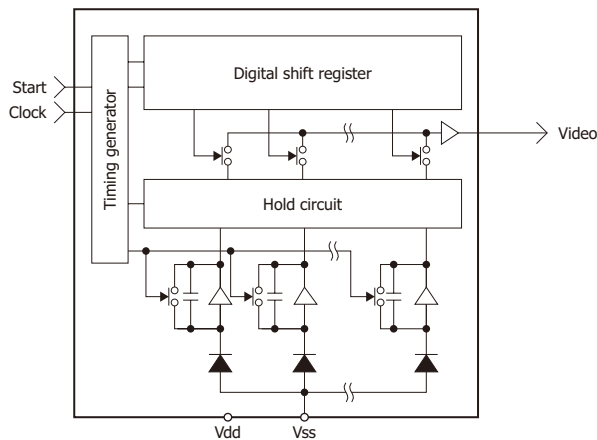

KMPDC0121EC

[CCD linear image sensor (S11155/S11156-2048-02)]

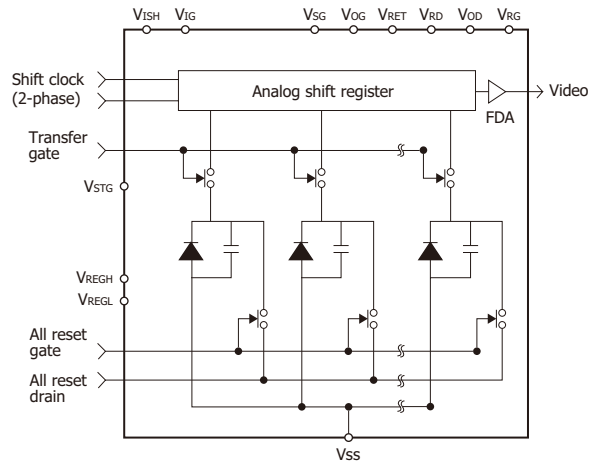

KMPDC0352EA

[NMOS linear image sensor (S3901 series)]

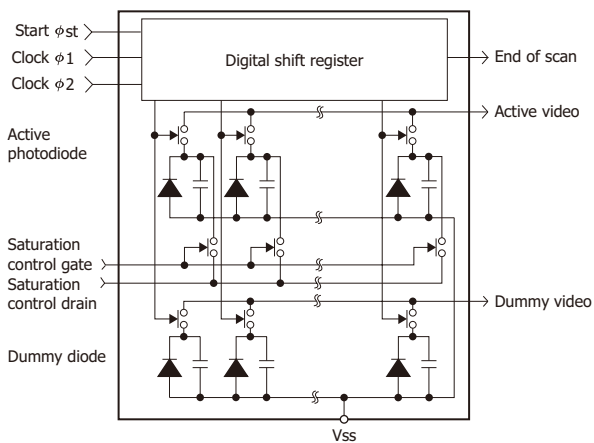



KMPDC0020EC

CMOS linear image sensors for spectrophotometry

These are CMOS linear image sensors suitable for spectrophotometry.

High sensitivity type

These are high sensitivity CMOS linear image sensors using a photosensitive area with vertically long pixels. Other features include high sensitivity and high resistance in the UV region.

Type no.	Pixel height (μm)	Pixel pitch (μm)	Number of pixels	Line rate max. (lines/s)	Photo	Dedicated driver circuit*1 (P.41)
S11639-01*2	200	14	2048	4672		C13015-01
S13496*2		7	4096	2387		
S13014*3		14	512	16556		—
S14739-20		14	256	28735		—

*1: Sold separately

*2: Types with light-shielding pixels (S11639-11, S13496-11) are available.

*3: Surface mount type (S13014-10) is available.

Features of the S11639-01

High sensitivity in the UV to near infrared region

For the photosensitive area, a buried photodiode structure is employed to reduce the dark current and shot noise in the dark state. Moreover, the photosensitive area features highly sensitive vertically long pixels but with low image lag, based on our original photosensitive area formation technology. In addition, high sensitivity is also provided for UV light.

Easy-to-operate

It operates on a single 5 V power supply and two types of external clock pulses. Since the input terminal capacitance of the clock pin is 5 pF, the image sensor can easily be operated with a simple external circuit. The video output is positive polarity. This product generates a readout timing trigger signal, which can be used to perform signal processing.

Spectral response (typical example)

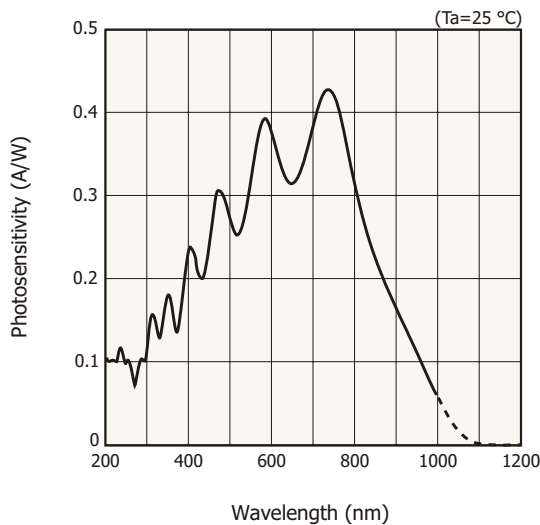

Output waveform of one pixel [f(CLK)=DR=10 MHz]

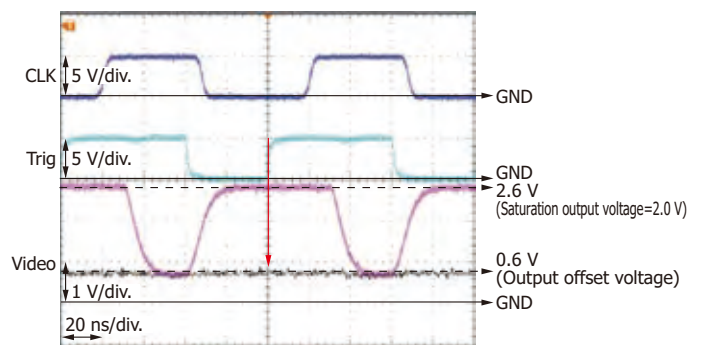

APS (active pixel sensor) type













This APS type image sensor consists of high-sensitivity amplifiers arranged for each pixel. It provides a high charge-to-voltage conversion efficiency of $25 \mu\text{V}/e^-$, which is higher than that of CCDs.

Electronic shutter, simultaneous charge integration for all pixels

The image sensor incorporates an electronic shutter function that can be used to control the start timing and length of the integration time in sync with an external clock pulse. The signals of all pixels are transferred to a hold capacity circuit where each pixel is read out one by one.

Variable integration time type

These current output type linear image sensors have a variable integration time function. The S10121 to S10124 series (-01) also have high sensitivity and smoothly varying spectral response characteristics in UV region.

Type no.	Pixel height (mm)	Pixel pitch (μm)	Number of pixels	Line rate max. (lines/s)	Photo	Dedicated driver circuit*4 (P.41)
S10121-128Q-01	2.5	50	128	1923		C10808 series
S10121-256Q-01			256	969		
S10121-512Q-01			512	486		
S10122-128Q-01	0.5		128	3846		
S10122-256Q-01			256	1938		
S10122-512Q-01			512	972		
S10123-256Q-01	0.5	25	256	1938		
S10123-512Q-01			512	972		
S10123-1024Q-01			1024	487		
S10124-256Q-01	2.5		256	969		
S10124-512Q-01			512	486		
S10124-1024Q-01			1024	243		

*4: Sold separately

Spectral response (typical example)

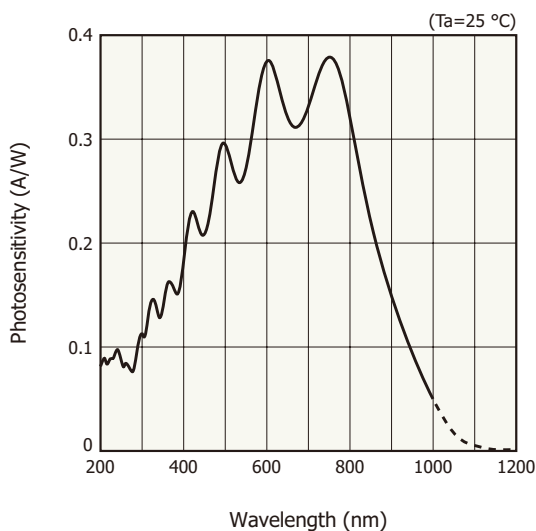

KMPDB0442EA



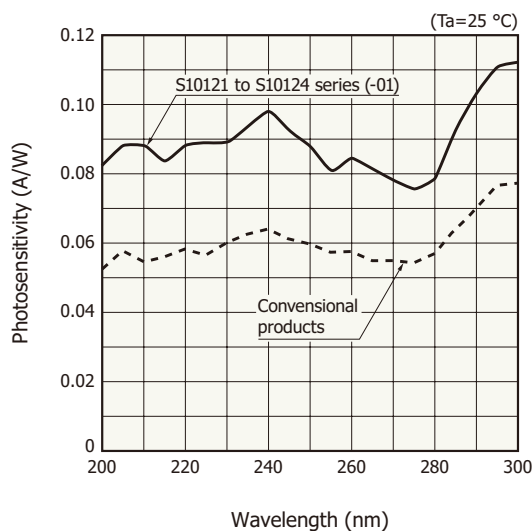







Spectral response in UV region (typical example)



KMPDB0443EA

Standard type

CMOS linear image sensors with internal readout circuit

Type no.	Pixel height (μm)	Pixel pitch (μm)	Number of pixels	Line rate max. (lines/s)	Photo	Dedicated driver circuit*1 (P41)
S8377-128Q	500	50	128	3846		C9001
S8377-256Q			256	1938		
S8377-512Q			512	972		
S8378-256Q		25	256	1938		
S8378-512Q			512	972		
S8378-1024Q			1024	487		
S9226-03	125	7.8	1024	194		-
S9226-04						
S9227-03	250	12.5	512	9434		-
S9227-04						



*1: Sold separately

CCD linear image sensors for spectrophotometry

The back-thinned type CCD linear image sensors are developed for spectrophotometers and feature high UV sensitivity and an internal electronic shutter. The front-illuminated type offers high sensitivity in the ultraviolet region (200 nm band) nearly equal to back-thinned CCD, despite a front-illuminated CCD.

Back-thinned type

These are back-thinned CCD linear image sensors with an internal electronic shutter for spectrometers. These image sensors use a resistive gate structure that allows a high-speed transfer.

Type no.	Pixel size [μm (H) \times μm (V)]	Number of effective pixels	Line rate (lines/s)	Cooling	Photo	Dedicated driver circuit*2 (P.41)
S11155-2048-02	14 \times 500	2048 \times 1	2327	Non-cooled		C11165-02
S11156-2048-02	14 \times 1000					
S13255-2048-02	14 \times 500					
S13256-2048-02	14 \times 1000				—	

*2: Sold separately

Note: Windowless type is available upon request.

Resistive gate structure

In ordinary CCDs, one pixel contains multiple electrodes and a signal charge is transferred by applying different clock pulses to those electrodes [Figure 1]. In resistive gate structures, a single high-resistance electrode is formed in the active area, and a signal charge is transferred by means of a potential slope that is created by applying different voltages across the electrode [Figure 2]. Compared to a CCD area image sensor which is used as a linear sensor by line binning, a one-dimensional CCD having a resistive gate structure in the active area offers higher speed transfer, allowing readout with low image lag even if the pixel height is large.

Figure 1 Schematic diagram and potential of ordinary 2-phase CCD

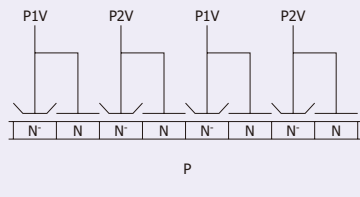
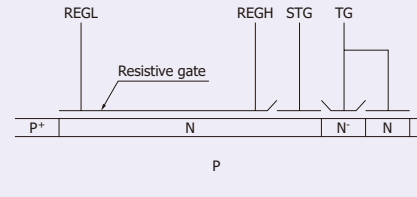



Figure 2 Schematic diagram and potential of resistive gate structure



Front-illuminated type

The S11151-2048 is a front-illuminated CCD linear image sensor with high sensitivity and high resistance to UV light.

Type no.	Pixel size [μm (H) \times μm (V)]	Pixel pitch (μm)	Number of effective pixels	Line rate (lines/s)	Photo	Dedicated driver circuit*1 (P.41)
S11151-2048	14 \times 200	14	2048 \times 1	484		C11160

*1: Sold separately

Note: Windowless type is available upon request.

Spectral response (without window, typical example)*2

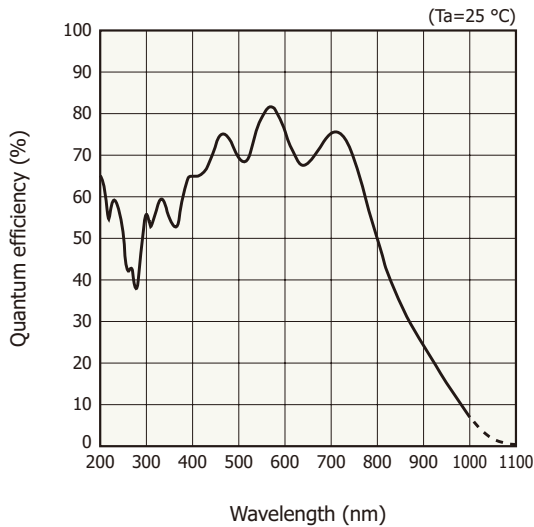



*2: Spectral response with quartz glass is decreased according to the spectral transmittance characteristic of window material.

NMOS linear image sensors for spectrophotometry



NMOS linear image sensors are self-scanning photodiode arrays designed specifically for detectors used in multichannel spectroscopy. These image sensors feature a large photosensitive area, high UV sensitivity and little sensitivity degradation with UV exposure, wide dynamic range due to low dark current and high saturation charge, superior output linearity and uniformity, and also low power consumption.

Current output type

NMOS linear image sensors offering excellent output linearity and ideal for spectrophotometry

Type no.	Pixel height (mm)	Pixel pitch (μm)	Number of pixels	Cooling	Photo	Dedicated driver circuit*3 (P.40, 41)
S3901 series	2.5	50	128, 256, 512	Non-cooled		C7884 series C8892
			1024			-
S3902 series	0.5	50	128, 256, 512		Non-cooled	
S3903 series		25	256, 512, 1024			



*3: Sold separately

Type no.	Pixel height (mm)	Pixel pitch (μm)	Number of pixels	Cooling	Photo	Dedicated driver circuit*4 (P.40, 41)
S3904 series	2.5	25	256, 512, 1024	Non-cooled		C7884 series C8892
			2048			–
S5930 series		50	256, 512	One-stage TE-cooled		C5964 series (built-in sensor)
S5931 series		25	512, 1024			

*4: Sold separately (excluding S5930/S5931 series)

Current output type (Infrared enhanced type)



NMOS linear image sensors having high sensitivity in near infrared region

Type no.	Pixel height (mm)	Pixel pitch (μm)	Number of pixels	Cooling	Photo	Dedicated driver circuit*5 (P.40, 41)
S8380 series	2.5	50	128, 256, 512	Non-cooled		C7884 series C8892
S8381 series		25	256, 512, 1024			
S8382 series		50	256, 512	One-stage TE-cooled		C5964 series (built-in sensor)
S8383 series		25	512, 1024			

*5: Sold separately (excluding S8382/S8383 series)

Voltage output type

These voltage output sensors need only a simple design circuit for readout compared to the current output type.

Type no.	Pixel height (mm)	Pixel pitch (μm)	Number of pixels	Cooling	Photo	Dedicated driver circuit
S3921 series	2.5	50	128, 256, 512	Non-cooled		–
S3922 series	0.5					
S3923 series	0.5	25	256, 512, 1024			
S3924 series	2.5					

CCD linear image sensors for industry

These are CCD linear image sensors suitable for industry.

TDI-CCD image sensors (Back-illuminated type)

TDI (time delay integration) -CCD captures clear, bright images even under low-light-level conditions during high-speed imaging. TDI operation mode drastically boosts sensitivity to high levels by integrating signal charges synchronously with the object movement. TDI-CCD uses a back-thinned structure to achieve even higher quantum efficiency over a wide spectral range from the UV to the near IR region (200 to 1100 nm).

Type no.	Pixel size [μm (H) \times μm (V)]	Number of effective pixels	Number of ports	Pixel rate (MHz/port)	Line rate (lines/s)	Vertical transfer	Photo	Compatible camera*1
S10200-02-01	12 \times 12	1024 \times 128	2	30	50000	Bi-directional		-
S10201-04-01		2048 \times 128	4					C10000-801 C10000-A01
S10202-08-01		4096 \times 128	8					-
S10202-16-01		4096 \times 128	16					-

*1: Sold separately

The C10000 series cameras are products manufactured by Hamamatsu Photonics, System Division.

Spectral response (without window)

The back-thinned (back-illuminated) structure ensures higher sensitivity than front-illuminated types in the UV through the near IR region (200 to 1100 nm).

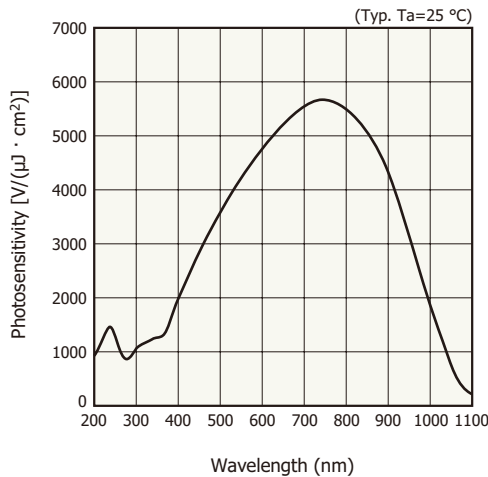

KMPDB0268EB

Sensor configuration (S10201-04-01)

Using multiple amplifiers (multiple output ports) permits parallel image readout at a fast line rate.

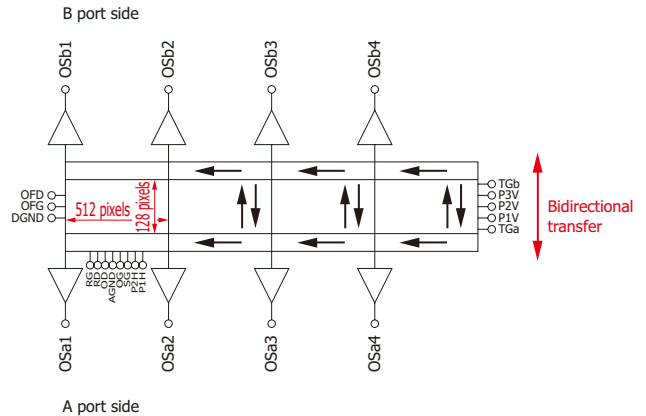

KMPDC0260EA

TDI mode

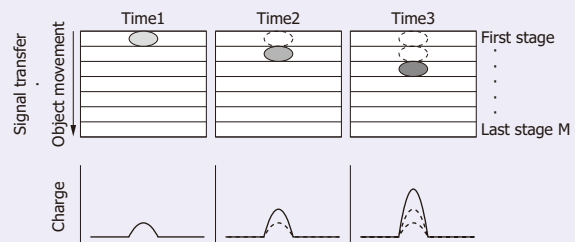

In FFT-CCD, signal charges in each line are vertically transferred during charge readout. TDI mode synchronizes this vertical transfer timing with the movement timing of the object incident on the CCD, so that signal charges are integrated a number of times equal to the number of vertical stages of the CCD pixels.



KMPDC0139EA

Front-illuminated type

These are front-illuminated type CCD linear image sensors with high-speed line rate designed for applications such as sorting machine and machine vision cameras.

Type no.	Pixel size [μm (H) \times μm (V)]	Number of effective pixels	Number of ports	Pixel rate max. (MHz/port)	Line rate max. (lines/s)	Photo	Dedicated driver circuit
S12551-2048	14 \times 14	2048 \times 1	1	40	19200*2		-
S12379	8 \times 8		4		72000		-









*2: With electronic shutter

CMOS linear image sensors for industry

CMOS linear image sensors incorporate a timing circuit and signal processing amplifiers integrated on the same chip, and operate from simple input pulses and a single power supply. Thus the external circuit can be simplified.

















Resin-sealed type package

These are CMOS linear image sensors of small and surface mounted type suited for mass production.

Type no.	Pixel height (μm)	Pixel pitch (μm)	Number of pixels	Line rate max. (lines/s)	Photo	Dedicated driver circuit
S10226-10	125	7.8	1024	194		-
S10227-10	250	12.5	512	9434		
S11106-10	63.5	63.5	128	64935		
S11107-10	127	127	64	111111		
S12443	125	7	2496	3924		
S13131-512	63.5	5.5	512	3774		
S13131-736			736	2653		
S13131-1536			1536	1287		
S13434-2496	63.5	5.25	2496	796		

High-speed readout type

These are CMOS linear image sensors with simultaneous charge integration and variable integration time function that allow high-speed readout.

Type no.	Pixel height (μm)	Pixel pitch (μm)	Number of pixels	Line rate max. (lines/s)	Photo	Dedicated driver circuit
S11637-1024Q	500	12.5	1024	9487		-
S11637-2048Q			2048	4812		
S12198-512Q-01		25	512	18450		
S12198-1024Q-01			1024	9487		
S11105	250	12.5	512	88495		
S11105-01						
 S13774	7	7	4096	100000		
S14416-02	63.5	63.5	256	35461		
S14416-06			768	12594		
 S14416-12			1536	6402		
 S14417-02	127	127	128	64935		
 S14417-06			384	24390		

High sensitivity type

CMOS linear image sensors that achieve high sensitivity by adding an amplifier to each pixel

Type no.	Pixel height (μm)	Pixel pitch (μm)	Number of pixels	Line rate max. (lines/s)	Photo	Dedicated driver circuit*1 (P.41)
S11108	14	14	2048	4672		-
S12706	7	7	4096	2387		C13015-01
S13488-01	42	14	2048	4672		-
S13828	84	28	1024	8960		-

*1: Sold separately

Digital output type

CMOS linear image sensor with internal 8-bit/10-bit A/D converter

Type no.	Pixel height (μm)	Pixel pitch (μm)	Number of pixels	Line rate max. (lines/s)	Photo	Dedicated driver circuit
S10077	50	14	1024	972		-

With RGB color filters

The S13488 is a CMOS linear image sensor that is sensitive to red (630 nm), green (540 nm), and blue (460 nm). Filters are attached to the pixels in the following order: R, G, and B.

Type no.	Pixel height (μm)	Pixel pitch (μm)	Number of pixels	Line rate max. (lines/s)	Photo	Dedicated driver circuit
S13488	42	14	2048	4672		-

Spectral response (typical example)

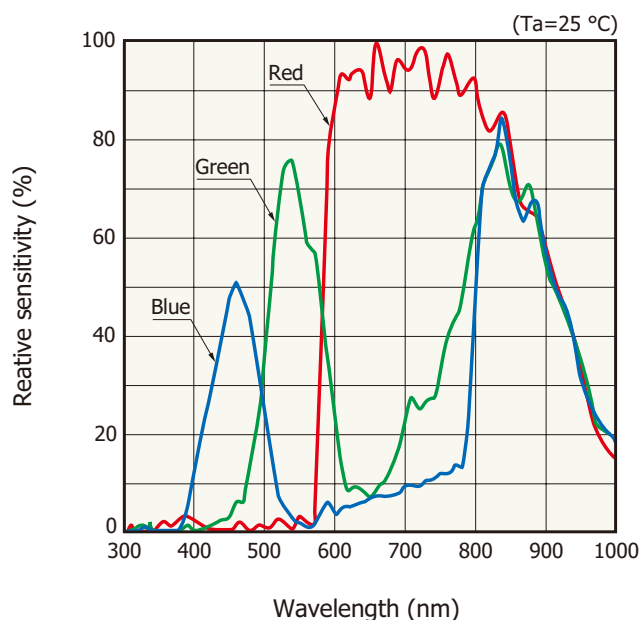

KMPDB0483EB

Note: This sensor also has sensitivity in the infrared region, so cut off infrared light as needed.

Photodiode arrays with amplifier

Photodiode arrays with amplifier are a type of CMOS linear image sensor designed mainly for long area detection systems using an equal-magnification optical system. This sensor has two chips consisting of a photodiode array chip for light detection and a CMOS chip for signal processing and readout. A long, narrow image sensor can be configured by arranging multiple arrays in a row.



Structure figure (S11865-64/-128)

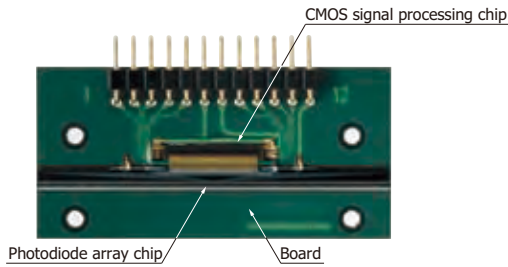

KMPDC0186EB

Block diagram (S11865-64/-128)

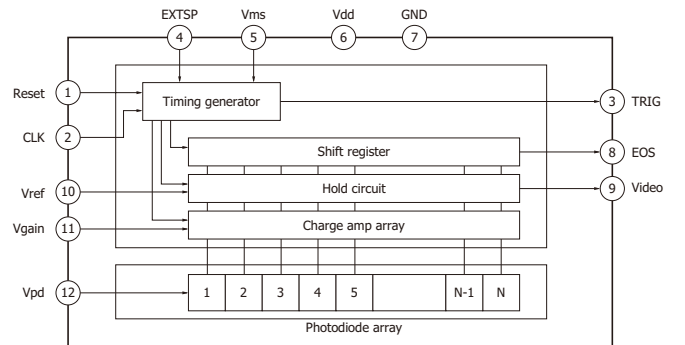

KMPDC0153EA

Long and narrow area type

Linear image sensors designed for industrial inspection

Type no.	Pixel height (mm)	Pixel pitch (mm)	Number of pixels	Supply voltage (V)	Line rate max. (lines/s)	Charge amp feedback capacitance (pF)	Photo	Dedicated driver circuit*1
S11865-64	0.8	0.8	64	5	14678	0.5		C9118 C9118-01
S11865-128	0.6	0.4	128	5	7568	0.5		
NEW S13885-128				3.3		0.125	-	
S11865-256	0.3	0.2	256	5	3844	0.5		-
NEW S13885-256				3.3		0.125		
S11866-64-02	1.6	1.6	64	5	14678	0.5		C9118 C9118-01
S11866-128-02	0.8	0.8	128	5	7568	0.5		
NEW S13886-128				3.3		0.125	-	

*1: Sold separately

Note: Types with a phosphor sheet are also available.

Driver circuits for photodiode arrays with amplifier

Type no.	Features	Connection	Photo	Suitable sensor
C9118	Single power supply (+5 V) Operation with two input signals (M-CLK and M-RESET)	For single/parallel connection		S11865-64 S11865-128 S11866-64-02 S11866-128-02
C9118-01		For serial connection		

Distance image sensors

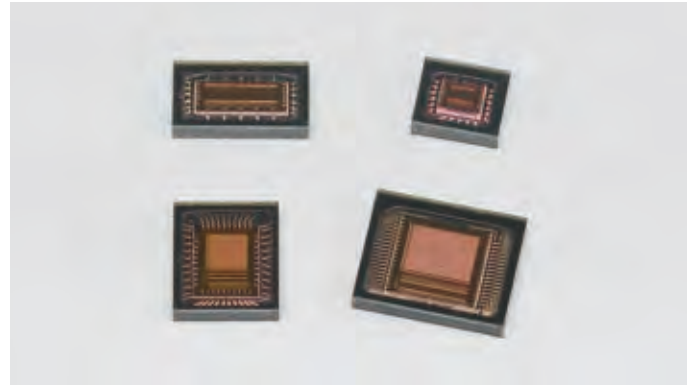

These distance image sensors are designed to measure the distance to an object by TOF method. When used in combination with a pulse modulated light source, these sensors output phase difference information on the timing that the light is emitted and received. The sensor output signals are arithmetically processed by an external signal processing circuit or a PC to obtain distance data.



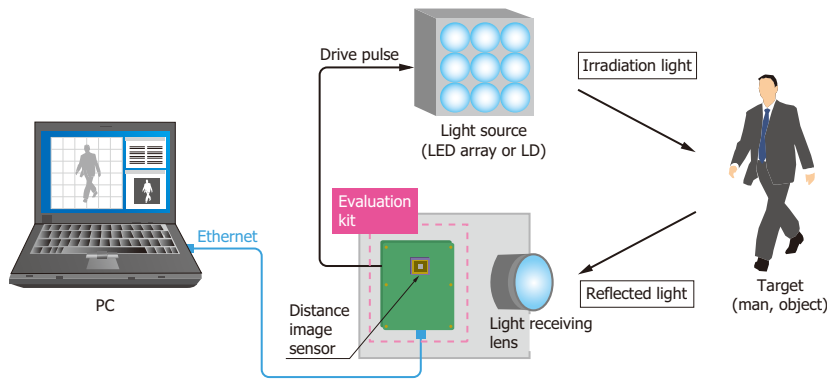

Example of distance measurement diagram



Distance linear image sensors

Type no.	Pixel height (μm)	Pixel pitch (μm)	Number of effective pixels	Video data rate max. (MHz)	Photo	Dedicated driver circuit
S11961-01CR	50	20	256	5		*
S12973-01CT		22	64			*

Distance area image sensors

Type no.	Pixel height (μm)	Pixel pitch (μm)	Number of effective pixels	Video data rate max. (MHz)	Photo	Dedicated driver circuit
S11962-01CR	40	40	64 × 64	10		-
S11963-01CR	30	30	160 × 120			*

* Please contact us for an evaluation kit.

Image sensors for near infrared region

InGaAs image sensors are designed for a wide range of applications in the near infrared region. Built-in CMOS ROIC readout circuit allows easy signal processing. These image sensors use a charge amplifier mode that provides a large output signal by integrating the charge, making them ideal for low-light-level detection.



Equivalent circuit (InGaAs linear image sensor)

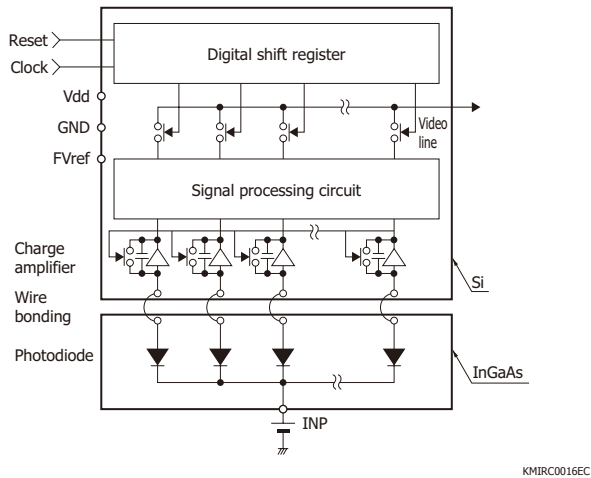

Spectral response



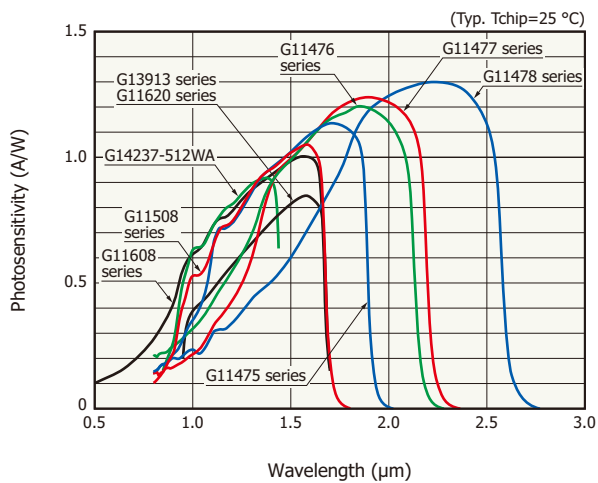

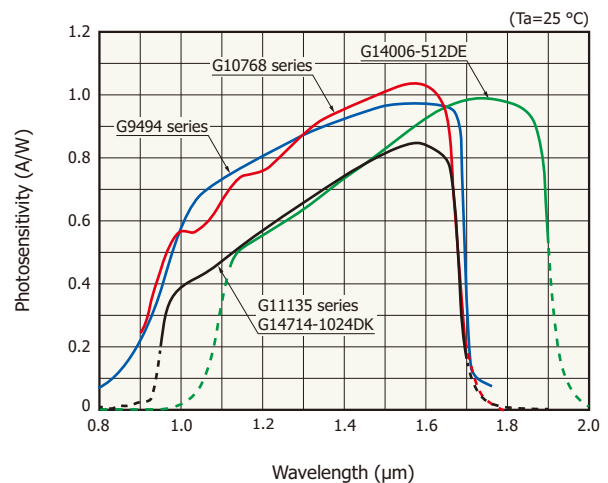

[InGaAs linear image sensors for spectrometry]



[High-speed type InGaAs linear image sensors]









Front-illuminated type

Type no.	Cooling	Pixel height (μm)	Pixel pitch (μm)	Number of pixels	Line rate max. (lines/s)	Spectral response range λ (μm)	Defective pixels	Photo	Dedicated driver circuit
G9203-256DA	Non-cooled	500	50	256	1910	0.9 to 1.7	0		—
G9204-512DA			25	512	960*1				
G11608-256DA			50	256	17200	0.5 to 1.7	1% max.		—
G11608-512DA			25	512	9150*1				
G11508-256SA	One-stage TE-cooled (Tchip=-10 °C)	500	50	256	17200	0.9 to 1.67	0		—
G11508-512SA			25	512	9150*1				
G11475-256WB	Two-stage TE-cooled (Tchip=-20 °C)	250	50	256	17200	0.9 to 1.85	5% max.		—
G11476-256WB						0.9 to 2.05			
G11477-256WB						0.9 to 2.15			
G11478-256WB						0.9 to 2.55			
G11475-512WB		25	512	9150*1	0.9 to 1.85	4% max.			
G11477-512WB					0.9 to 2.15				
G11478-512WB					0.9 to 2.55				
G14237-512WA					500		0.85 to 1.4		

*1: When two video lines are used for readout, the line rate is equal to that for 256 channels.



Back-illuminated type

Type no.	Cooling	Pixel height (μm)	Pixel pitch (μm)	Number of pixels	Line rate max. (lines/s)	Spectral response range λ (μm)	Defective pixels	Photo	Dedicated driver circuit*2 (P.42)
G11620-128DA	Non-cooled	500	50	128	30800	0.95 to 1.7	1% max.		C11513
G11620-256DA				256	17200				
G11620-256DF			25	256	17200				
G11620-512DA				512	9150				
G13913-128FB		250	50	128	13600				—
G13913-256FG			25	256	7290				
G11620-256SA	One-stage TE-cooled (Tchip=-10 °C)	500	50	256	17200	0.95 to 1.67	1% max.		—
G11620-512SA			25	512	9150				
G12230-512WB	Two-stage TE-cooled (Tchip=-20 °C)	250	25	512	9150	0.95 to 2.15	2% max.		—

*2: Sold separately

Front-illuminated type

These are linear image sensors with high-speed data rate designed for industrial measuring instruments.

Type no.	Cooling	Pixel height (μm)	Pixel pitch (μm)	Number of pixels	Line rate max. (lines/s)	Spectral response range λ (μm)	Defective pixels	Photo	Dedicated driver circuit*1 (P.42)
G9494-256D	Non-cooled	50	50	256	7100	0.9 to 1.7	1% max.		C10820
G9494-512D		25	25	512	3720*2				

*1: Sold separately

*2: When two video lines are used for readout, the line rate is equal to that for 256 channels.





The G10768 series is a high-speed infrared image sensor with 1024 pixels designed for applications such as foreign object screening and medical diagnostic equipment where a multichannel high-speed line rate is required.

Type no.	Cooling	Pixel height (μm)	Pixel pitch (μm)	Number of pixels	Line rate max. (lines/s)	Spectral response range λ (μm)	Defective pixels	Photo	Dedicated driver circuit*3 (P.40)
G10768-1024D	Non-cooled	100	25	1024	39000	0.9 to 1.7	1% max.		C10854
G10768-1024DB		25							

*3: Sold separately

Back-illuminated type







The back-illuminated InGaAs photodiode and CMOS-ROIC are bump bonded to provide a single output terminal.

Type no.	Cooling	Pixel height (μm)	Pixel pitch (μm)	Number of pixels	Line rate max. (lines/s)	Spectral response range λ (μm)	Defective pixels	Photo	Dedicated driver circuit*4 (P.42)
G11135-256DD	Non-cooled	50	50	256	14000	0.95 to 1.7	1% max.		C11514
G11135-512DE		25	25	512	8150				
 G14714-1024DK		12.5	12.5	1024	40000				—
G14006-512DE		25	25	512	8150	1.12 to 1.9		C11514	

*4: Sold separately

InGaAs area image sensors

The InGaAs area image sensors have a hybrid structure consisting of a CMOS readout circuit (ROIC: readout integrated circuit) and back-illuminated InGaAs photodiodes.

Type no.	Cooling	Pixel height (μm)	Pixel pitch (μm)	Number of pixels	Frame rate max. (frames/s) ^{*5}	Spectral response range λ (μm)	Defective pixels	Photo	Dedicated driver circuit ^{*6} (P.40)	
G11097-0606S	One-stage TE-cooled (Tchip=25 °C)	50	50	64 × 64	1025	0.95 to 1.7	1% max.		C11512	
G12460-0606S	One-stage TE-cooled (Tchip=0 °C)					1.12 to 1.9				
G12242-0707W	Two-stage TE-cooled (Tchip=15 °C)	20	20	128 × 128	258	0.95 to 1.7	1% max.		C11512-02	
G13393-0808W				320 × 256	228		0.37% max.			
G13393-0909W				640 × 512	62					
NEW G14671-0808W	Two-stage TE-cooled (Tchip=15 °C)	20	20	320 × 256	500	0.95 to 1.7	0.37% max.		-	
NEW G14672-0808W	Two-stage TE-cooled (Tchip=-20 °C)						1.12 to 1.85			1% max.
NEW G14673-0808W							1.3 to 2.15			
NEW G14674-0808W	1.7 to 2.55									

*5: Integration time 1 μs (min.)

*6: Sold separately

Partial readout function (G14671/G14672/G14673/G14674-0808W)

The partial readout function reads one area per frame. The G14671/G14672/G14673/G14674-0808W have a function for switching the number of readout ports (4 ports or 1 port). The partial readout function can only be used for 1-port readout. The readout area is specified with a start coordinate (m, n) and end coordinate (p, q) [see the lower right figure (Partial readout)].

All-pixel readout

Readout area: All pixels [320 (H) × 256 (V)]

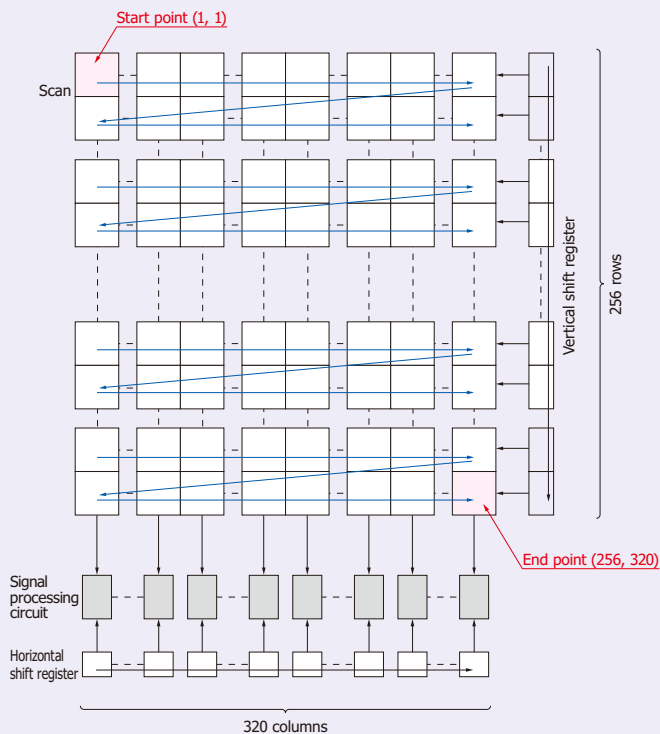

KMIRC0123EA

Partial readout

Readout area: Columns n to q (H), rows m to p (V)

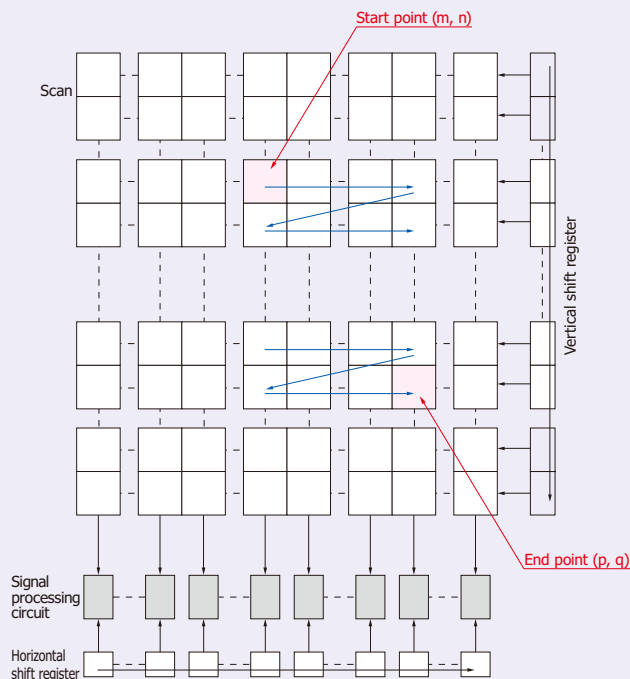

KMIRC0124EA

X-ray image sensors

Cesium Iodide Scintillator on Fiber Optic Plate

With the CCD with a CsI type FOS (FOP with X-ray scintillator), the FOP functions as a shield, so X-ray damage on the CCD can be suppressed. In addition to FOS, FOP coupling is also possible. Note that products that employ GOS for the scintillator are also available as low cost types.

The TDI-CCD S7199-01 and S8658-01 can provide cross-sectional X-ray imaging of large objects through TDI operation. It can be used not only in X-ray radiography equipment but also for industrial inline non-destructive inspections.

The photodiode arrays with amplifiers that have a phosphor sheet affixed on the photosensitive area can be used in various types of inspection equipment such as inline industrial product inspection equipment and foreign matter inspection of canned and retort food.



X-ray image examples

[taken with S10810-11]



[taken with S8658-01]





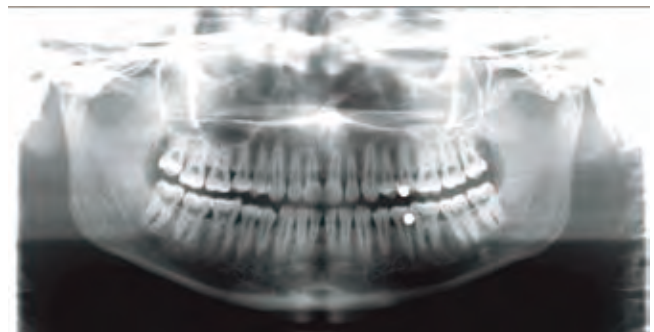

[taken with S7199-01]



CCD area image sensors for X-ray radiography

CCD image sensors with large photosensitive area and high resolution are used in X-ray radiography.





Type no.	Scintillator	Pixel size [μm (H) \times μm (V)]	Number of effective pixels	Frame rate* ¹ (frames/s)	Photo	Dedicated driver circuit
S8980	CsI (+ FOP)	20 \times 20	1500 \times 1000	2		-
S10810-11				1		
S10814			1			
S10811-11			1 (max.)			
S8984-02	Without scintillator* ²			1		

*1: Area scanning

*2: Coupled with FOP

CMOS area image sensors for X-ray radiography

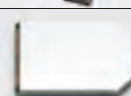
CMOS image sensors with large photosensitive area and high resolution are used in X-ray radiography.

Type no.	Scintillator	Pixel size [μm (H) \times μm (V)]	Number of effective pixels	Frame rate (frames/s)	Photo	Dedicated driver circuit
S10830-12	CsI (+ FOP)	20 \times 20	1000 \times 1500	0.9		-
S10834-12						
S10831			1300 \times 1700	0.6		
S10835-12						

Photosensitive area

[S10830-12, S10834-12]

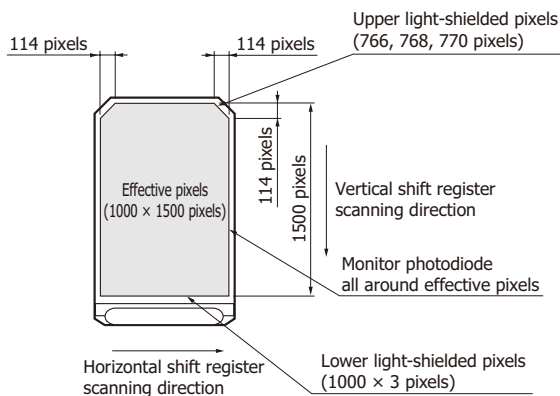

KMPDC0448EA

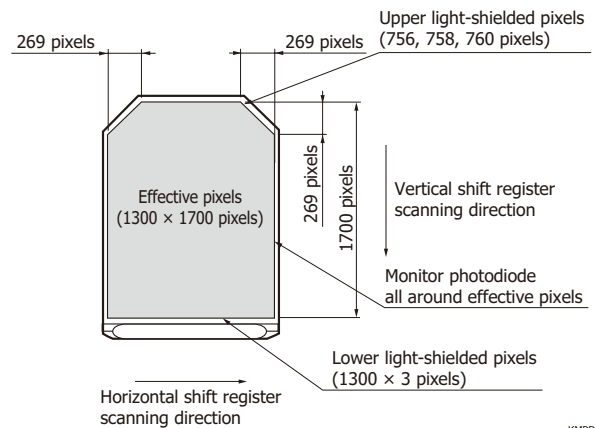

[S10831, S10835-12]



KMPDC0449EA

TDI-CCD area image sensors

These CCDs are long and narrow type FFT-CCD area image sensors coupling FOS. CCD chips are linearly arranged in close proximity to form a long and narrow sensor format. They are used for X-ray radiography or non-destructive inspection.





Type no.	Scintillator	Pixel size [μm (H) \times μm (V)]	Number of effective pixels	Frame rate*1 (frames/s)	Photo	Dedicated driver circuit
S7199-01*2	CsI (+ FOP)	48 \times 48	1536 \times 128 (2-chip buttable)	15		–
S8658-01*2			1536 \times 128 (3-chip buttable)			–

*1: Area scanning

*2: The types coupling FOP (S7199-01F, S8658-01F) are provided.

Photodiode arrays with amplifier for non-destructive inspection

Photodiode arrays with amplifier having phosphor sheet affixed on the photosensitive area are allowed for non-destructive inspection

Type no.	Pixel height (mm)	Pixel pitch (mm)	Number of pixels	Supply voltage (V)	Line rate (lines/s)	Charge amp feedback capacitance (pF)	Photo	Dedicated driver circuit*3
S11865-64G	0.8	0.8	64	5	14678	0.5		C9118 C9118-01
S11865-128G	0.6	0.4	128	5	7568	0.5		
S13885-128G	0.6	0.4	128	3.3	7568	0.125		
S11865-256G	0.3	0.2	256	5	3844	0.5		–
S13885-256G	0.3	0.2	256	3.3	3844	0.125		
S11866-64G-02	1.6	1.6	64	5	14678	0.5		C9118 C9118-01
S11866-128G-02	0.8	0.8	128	5	7568	0.5		
S13886-128G	0.8	0.8	128	3.3	7568	0.125		–

*3: Sold separately

Driver circuits for photodiode arrays with amplifier

Type no.	Features	Connection	Photo	Compatible sensor
C9118	Single power supply (+5 V) Operation with two input signals (M-CLK and M-RESET)	For single/parallel connection		S11865-64G S11865-128G S11866-64G-02 S11866-128G-02
C9118-01		For serial connection		

X-ray flat panel sensors

X-ray flat panel sensors are digital X-ray image sensors developed as key devices for rotational radiography (CT) and other real-time X-ray imaging applications requiring high sensitivity and high image quality. Flat panel sensors consist of a sensor board and a control board, both assembled in a thin, flat and compact configuration.

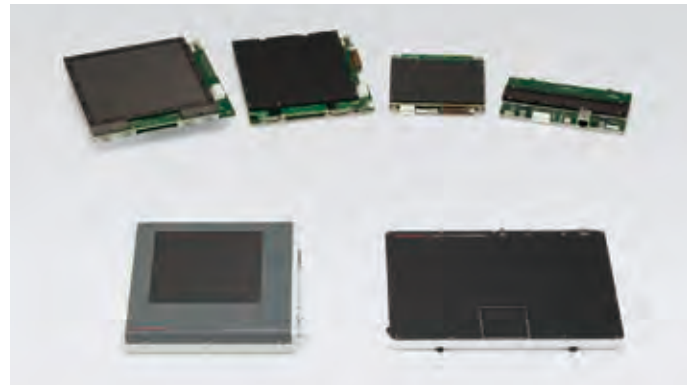

Rotational type for radiography



These are flat panel sensors for high-speed operation.

Type no.	Photodiode area (mm)	Scan mode	Output	Number of active pixels [(H) × (V)]	Pixel size (μm)	Maximum frame rate (frames/s)	Resolution (line pairs/mm)	Photo
C10901D-40	100.8 × 68.2	Fast mode	Digital (13-bit)	496 × 336	200 × 200	60	2.5	
		Fine mode	Digital (12-bit)	992 × 672	100 × 100	30	4.5	
		Panoramic mode		992 × 72		265		
C12902D-40	144.0 × 119.5	Fast mode	Digital (16-bit)	600 × 494	240 × 240	80	2.1	
		Fine mode		1200 × 988		120 × 120	30	
		Panoramic mode		1200 × 50	400			
		Rtbin panoramic mode		1200 × 25	120 × 240	600	—	
C12903D-40	140.0 × 122.8	Fast mode	Digital (16-bit)	696 × 606	200 × 200	60	2.5	
		Fine mode		1400 × 1212		100 × 100	19	
		Panoramic mode		1400 × 60	350			
		Rtbin panoramic mode		1400 × 30	100 × 200	600	—	
C12504D-56	149.8 × 60	Normal mode	Digital (14-bit)	1234 × 50	120 × 120	400	4.2	
		Rtbin mode		1234 × 25		120 × 240	780	
C10500D-70	151.2 × 60	Normal mode	Digital (14-bit)	1480 × 60	100 × 100	310	4.5	
		Rtbin mode		1480 × 30		100 × 200	500	
C12505D-56	224.6 × 60	Normal mode	Digital (14-bit)	1860 × 50	120 × 120	400	4.2	
		Rtbin mode		1860 × 25		120 × 240	780	
C10502D-70	226.8 × 60	Normal mode	Digital (14-bit)	2232 × 60	100 × 100	310	4.5	
		Rtbin mode		2232 × 30		100 × 200	500	

Note: The interface for all of above products is Gigabit Ethernet.

For radiography (biochemical imaging)

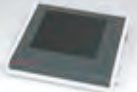
These are flat panel sensors for low energy X-ray.

Type no.	Photodiode area (mm)	Number of active pixels [(H) × (V)]	Pixel size (μm)	Output	Maximum frame rate*1 (frames/s)	Resolution (line pairs/mm)	Interface	Photo
C7942CK-22	120 × 120	2240 × 2344	50 × 50	Digital (12-bit)	2	8	RS-422 (differential)	
C9730DK-10	52.8 × 52.8	1032 × 1032		Digital (14-bit)	4	10	USB 2.0	
C9732DK-11	120 × 120	2368 × 2340			1			

*1: Single operation

General type (off-line)

These are flat panel sensors employing a high-quality CsI scintillator. They feature high resolution suitable for non-destructive inspection. They are suitable for use in combination with sealed type micro focus X-ray sources (50 kVp to 100 kVp).

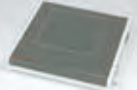
Type no.	Photodiode area (mm)	Number of active pixels [(H) × (V)]	Pixel size (μm)	Output	Maximum frame rate*2 (frames/s)	Resolution (line pairs/mm)	Interface	Photo
C7921CA-29	52.8 × 52.8	1032 × 1032	50 × 50	Digital (12-bit)	4	8	RS-422 (differential)	
C7942CA-22	120 × 120	2240 × 2344			2			

*2: Single operation

Low noise type

The C9728DK-10 is suitable for applications including diffraction.

Type no.	Photodiode area (mm)	Number of active pixels [(H) × (V)]	Pixel size (μm)	Output	Maximum frame rate (frames/s)	Noise (electrons)	Interface	Photo
C9728DK-10	52.8 × 52.8	1032 × 1032	50 × 50	Digital (14-bit)	3	80	USB 2.0	

Connection example of flat panel sensors (Interface: LVDS, RS-422)

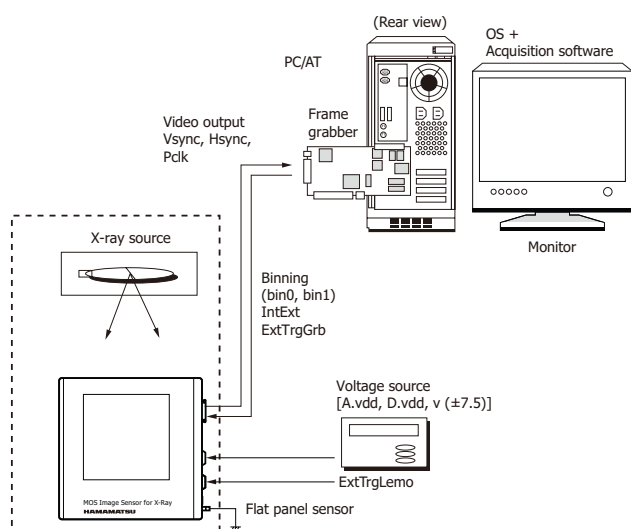

X-ray image examples

[Hornet (taken with general type flat panel sensor)]



[Fish (taken with flat panel sensor for radiography)]



Related products for image sensors



Driver circuits and multichannel detector heads compatible with our main image sensors are available to easily evaluate and test Hamamatsu image sensors. The driver circuit is a circuit board type and can be used to evaluate the image sensor at low cost. It can also be integrated into a device. The multichannel detector head is a product that houses a driver circuit in a heat dissipating case.



Multichannel detector heads









Image sensors have excellent performance characteristics, but more sophisticated electronics and signal processing are required for driving image sensors than when using single-element devices. To make it easier to use image sensors, Hamamatsu provides multichannel detector heads designed for CCD/NMOS/InGaAs image sensors. These multichannel detector heads operate with the dedicated controller or software for easy data acquisition and sensor evaluation and, can extract full performance from image sensors when installed in a measurement system.

For front-illuminated type CCD area image sensors

Type no.	Output	Photo	Compatible sensor	
C7020	Analog		S9970 series	Sold separately
C7020-02			S9972 series	
C7021			S9971-0906/-1006/-1007	
C7021-02			S9973-1007	
C7025			S9971-1008	
C7025-02			S9973-1008	

For back-thinned type CCD area image sensors

Type no.	Output	Photo	Compatible sensor	
C7040	Analog		S7030 series	Sold separately
C7041			S7031 series	

Type no.	Output	Photo	Compatible sensor
C7043	Analog		S7033 series
C7044			S7034 series
C7180			S7170-0909
C7181			S7171-0909-01
 C10150-01			S10140 series (-01)
 C10151-01			S10141 series (-01)

Sold separately

Note: Multichannel detector heads for two-stage TE-cooled type CCD area image sensors (back-thinned type) S7032 series are also available.

Multichannel detector head controller

Supports main multichannel detector heads designed to use a CCD image sensor or an NMOS linear image sensor

Type no.	Interface	Photo	Compatible multichannel detector head
C7557-01	USB 2.0/3.0		C7020/-02, C7021/-02, C7025/-02, C7040, C7041, C7043, C7044, C7180, C7181, C5964 series, C8892, C10150-01, C10151-01

Accessories

- Spare fuse (2.5 A)
- AC cable
- 2 to 3 conversion adapter
- USB cable
- Detector head connection cables (for "SIGNAL I/O" and "TE CONTROL I/O" terminal of multichannel detector head)
- CD-R (MCD USB driver, software, operation manual)
- MOS adapter

Connection examples (C7557-01)

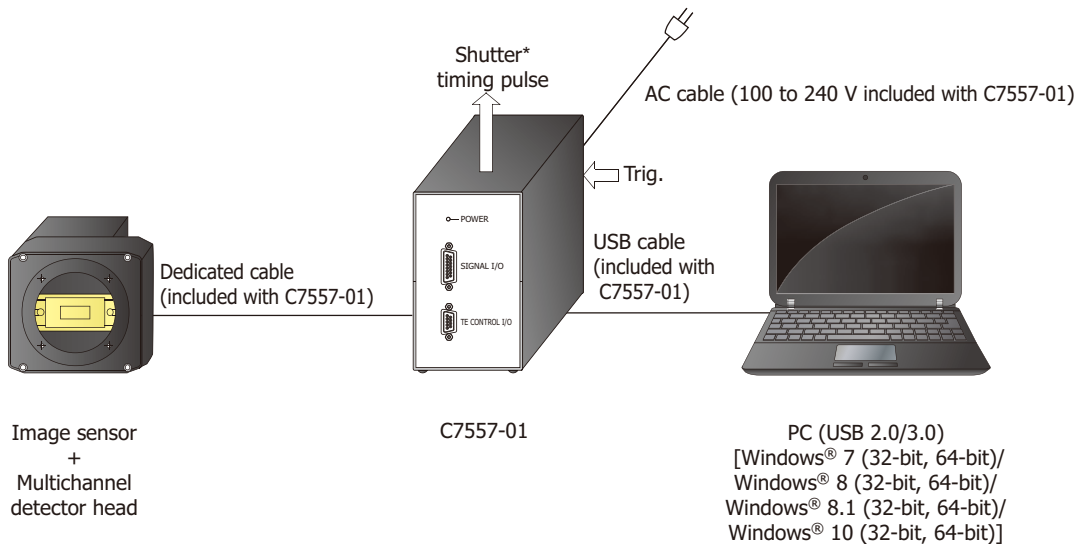

* Shutter, etc. are not available.

KACCCD402EE

Note: Windows is a registered trademark of Microsoft Corporation in the United States and other countries.

For NMOS linear image sensors

Type no.	Output	Photo	Compatible sensor	
C5964 series	Analog		S5930/S5931/S8382/S8383 series	Built-in sensor
C8892			S3901 to S3904/S8380/S8381 series (excluding S3901-1024Q and S3904-2048Q)	Sold separately

Note: Controller for multichannel detector head is available. Refer to P39 for details.

For InGaAs linear image sensors

Type no.	Output	Photo	Compatible sensor	
C10854	CameraLink		G10768-1024D G10768-1024DB	Sold separately





For InGaAs area image sensors

Type no.	Output	Photo	Compatible sensor	
C11512	CameraLink		G11097-0606S G12460-0606S	Sold separately
C11512-02			G12242-0707W	

Driver circuits for image sensors



Driver circuits designed for image sensors are available.

For CCD image sensors



Type no.	Signal frequency	Interface	Photo	Compatible sensor
C11287	250 kHz	USB 2.0		S10420-01 series
C11288	4 MHz			S11071 series
C11160	1 MHz			S11151-2048
C11165-02	6 MHz			S11155-2048-02 S11156-2048-02
C11860	250 kHz			S11850-1106 S14651 series

Sold separately



For NMOS linear image sensors (Current output type)

Type no.	Feature	Photo	Compatible sensor
C7884	High-precision driver circuit		S3901 to S3904 series S8380/S8381 series (excluding S3901-1024Q and S3904-2048Q)
C7884-01	Low noise driver circuit		

For CMOS linear image sensors

Type no.	Feature	Photo	Compatible sensor
C9001	Single power supply (+5 V) Operation with two input signals (clock and start)		S8377/S8378 series
C10808 series	With variable integration time function High-speed readout type (C10808) and low noise type (C10808-01) are available.		S10121 to S10124-01 series
C13015-01	Built-in 16-bit A/D converter Interface: USB 2.0 Single power supply: USB bus power (+5 V)		S11639-01, S12706, S13496

For InGaAs linear image sensors

Type no.	Feature	Photo	Compatible sensor
C10820	High gain setting suitable for low-level-light		G9494-256D G9494-512D
C11513	USB 2.0 interface (USB bus power)		G11620 series (G11620-256SA/-512SA: incompatible)
C11514	CameraLink		G11135 series G14006-512DE

Connection example (C11514)

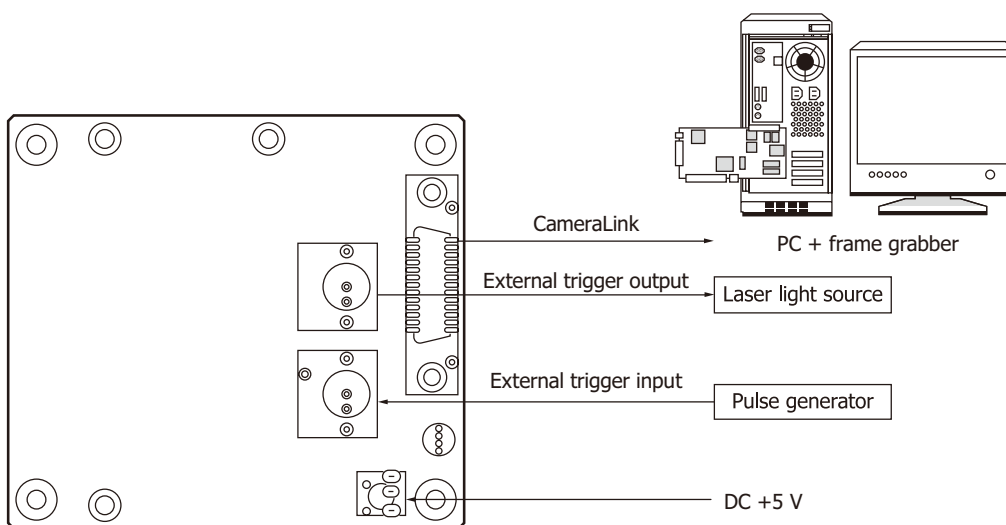

[C11514]

KACCC0869EA

Accessories (C11514)

- Application software (DCam-CL)
- Function library (SSDic.dll)
- AC adapter

Note: A National Instruments frame grabber board and NI-IMAQ are required to use the supplied application software (DCam-CL) and function library (SSDic.dll). Operation of the following frame grabber boards has been verified.

Manufacturer	Model no.	Supported OS	Driver
National Instruments	PCIe-1427	Windows® 7 (32-bit, 64-bit), Windows® 10 (32-bit, 64-bit)	National Instruments tool (supplied with NI-IMAQ)
	PCIe-1429		
	PCIe-1430		
	PCIe-1433		

Note: Windows is a registered trademark of Microsoft Corporation in the United States and other countries.

Disclaimer

- Products manufactured by Hamamatsu Photonics K.K. (hereafter “Hamamatsu”) are intended for use in general-use electronic devices (such as measurement equipment, office equipment, information communications equipment, household appliances, etc.). Unless an exception to the following is stated in the documentation of a specific product, Hamamatsu products are not to be used for special applications which demand extremely high reliability or safety (such as equipment for nuclear power control, aerospace equipment, medical equipment and transportation equipment that directly affect human life, or disaster prevention or safety equipment).
- Hamamatsu products should not be used in excess of their absolute maximum ratings. Attention must be paid to all documented precautions.
- Hamamatsu continually makes efforts to improve the quality and reliability of its products; however these efforts cannot ensure 100% compliance with the manufacturing specifications. Sufficient safety design (such as redundant safety, fire preventative, and malfunction preventative features) are to be implemented in the development of equipment manufactured with the Hamamatsu product so that personal injury, fire, or damage to public property or welfare does not occur in the unlikely event of a malfunction of the Hamamatsu product. A dangerous condition could be created if sufficient consideration is not given to safety design that addresses potential problems, especially in the design of equipment where the failure or malfunction of the Hamamatsu product within the equipment could result in bodily harm, life-threatening injury, or serious property damage during the use of the equipment. With such types of equipment, Hamamatsu shall not be responsible for the use of its products within the equipment in any way for not obtaining our written consent such as specification sheets beforehand.
- Appropriate descriptions of the functions, performance, and methods of operation of the Hamamatsu product and the equipment within which the Hamamatsu product is incorporated are to be provided to end-users of the equipment. All accompanying warnings and cautionary labeling are also to be provided to the end-user.
- Warranty of the Hamamatsu product is limited to the repair or replacement of a product in which a defect is discovered within 1 year of delivery of the product and notification is made to Hamamatsu within that period, otherwise certain warranty is specified. However, even within the warranty period Hamamatsu shall not be responsible for damages caused by either natural disaster or improper use of the product (such as modification of the product or any use that contravenes the operating conditions, intended applications, operating instructions, storage method, disposal method, or any other term or condition described in our products’ documents). For a complete description of the warranty associated with a particular product, please contact your regional Hamamatsu sales office.
- Exportation of some Hamamatsu products must comply with individual governmental regulations pertaining to export control. Export in contravention of governmental regulations is a crime and can result in severe monetary penalties or imprisonment. While we cannot give any legal advice as to how to comply with these regulations, we can help classify the goods in order to assist the buyer in determining what regulations apply. Please contact your regional Hamamatsu sales office for further assistance.
- In our products’ documents, applications are mentioned as notable examples of how the Hamamatsu product can be used. Such mentions guarantee neither the suitability of the product for specific purposes nor the success or failure of the commercial use of the product in specific applications. Some applications may be protected by patents or other proprietary rights. Hamamatsu assumes no liability for any infringing use of our products. All warranties express or implied, including any warranty of merchantability or fitness for any particular purpose are hereby excluded.
- Product specifications are subject to change without notification due to product improvements, etc. Our products’ documents have been carefully prepared to ensure the accuracy of the technical information contained herein, but in rare cases there may be errors. When using the Hamamatsu product, please be sure to request the delivery specification sheets, and confirm upon delivery that it is the most recent specifications. In addition to this document, please be sure to read any accompanying technical documentation and make note of any precautions listed in the delivery specification sheets.
- All Rights Reserved, transfer or duplication of the contents of our products’ documents without the permission of Hamamatsu is prohibited.

HAMAMATSU

HAMAMATSU PHOTONICS K.K., Solid State Division

1126-1, Ichino-cho, Higashi-ku, Hamamatsu City, 435-8558, Japan

Telephone: (81)53-434-3311, Fax: (81)53-434-5184

www.hamamatsu.com

Main Products

Opto-semiconductors

Si photodiodes
APD
MPPC
Photo IC
Image sensors
PSD
Infrared detectors
LED
Optical communication devices
Automotive devices
X-ray flat panel sensors
Mini-spectrometers
Opto-semiconductor modules

Electron tubes

Photomultiplier tubes
Photomultiplier tube modules
Microchannel plates
Image intensifiers
Xenon lamps / Mercury xenon lamps
Deuterium lamps
Light source applied products
Laser applied products
Microfocus X-ray sources
X-ray imaging devices

Imaging and processing systems

Cameras / Image processing measuring systems
X-ray products
Life science systems
Medical systems
Semiconductor failure analysis systems
FPD / LED characteristic evaluation systems
Spectroscopic and optical measurement systems

Laser products

Semiconductor lasers
Applied products of semiconductor lasers
Solid state lasers

Information in this catalogue is believed to be reliable. However, no responsibility is assumed for possible inaccuracies or omissions. Specifications are subject to change without notice. No patent rights are granted to any of the circuits described herein.

© 2019 Hamamatsu Photonics K.K.

Quality, technology, and service are part of every product.

Sales Offices

Japan:

HAMAMATSU PHOTONICS K.K.

325-6, Sunayama-cho, Naka-ku,
Hamamatsu City, Shizuoka Pref. 430-8587, Japan
Telephone: (81)53-452-2141, Fax: (81)53-456-7889
E-mail: intl-div@hq.hpk.co.jp

China:

HAMAMATSU PHOTONICS (CHINA) Co., Ltd.

Main Office
1201 Tower B, Jiaming Center, 27 Dongsanhuan Beilu,
Chaoyang District, 100020 Beijing, P.R.China
Telephone: (86)10-6586-6006, Fax: (86)10-6586-2866
E-mail: hpc@hamamatsu.com.cn

Shanghai Branch

4905 Wheelock Square, 1717 Nanjing Road West,
Jingan District, 200040 Shanghai, P.R.China
Telephone: (86)21-6089-7018, Fax: (86)21-6089-7017

Taiwan:

HAMAMATSU PHOTONICS TAIWAN Co., Ltd.

Main Office
8F-3, No.158, Section2, Gongdao 5th Road,
East District, Hsinchu, 300, Taiwan R.O.C.
Telephone: (886)3-659-0080, Fax: (886)3-659-0081
E-mail: info@hamamatsu.com.tw

U.S.A.:

HAMAMATSU CORPORATION

Main Office
360 Foothill Road, Bridgewater, NJ 08807, U.S.A.
Telephone: (1)908-231-0960, Fax: (1)908-231-1218
E-mail: usa@hamamatsu.com

California Office

2875 Moorpark Ave. San Jose, CA 95128, U.S.A.
Telephone: (1)408-261-2022, Fax: (1)408-261-2522
E-mail: usa@hamamatsu.com

Chicago Office

4711 W.Golf Road, Suite 805, Skokie, IL 60076, U.S.A.
Telephone: (1)847-825-6046, Fax: (1)847-825-2189
E-mail: usa@hamamatsu.com

Boston Office

20 Park Plaza, Suite 312, Boston, MA 02116, U.S.A.
Telephone: (1)617-536-9900, Fax: (1)617-536-9901
E-mail: usa@hamamatsu.com

United Kingdom:

HAMAMATSU PHOTONICS UK Limited

Main Office
2 Howard Court, 10 Tewin Road, Welwyn Garden City,
Hertfordshire AL7 1BW, UK
Telephone: (44)1707-294888, Fax: (44)1707-325777
E-mail: info@hamamatsu.co.uk

South Africa Contact:

9 Beukes Avenue, Highway Gardens, Edenvale
1609 South Africa
Telephone/Fax: (27)11-609-0367

France, Portugal, Belgium, Switzerland, Spain:

HAMAMATSU PHOTONICS FRANCE S.A.R.L.

Main Office
19, Rue du Saule Trapu, Parc du Moulin de Massy,
91882 Massy Cedex, France
Telephone: (33)1 69 53 71 00, Fax: (33)1 69 53 71 10
E-mail: infos@hamamatsu.fr

Swiss Office

Dornacherplatz 7, 4500 Solothurn, Switzerland
Telephone: (41)32-625-60-60, Fax: (41)32-625-60-61
E-mail: swiss@hamamatsu.ch

Belgian Office

Axisparc Technology, rue Andre Dumont 7
1435 Mont-Saint-Guibert, Belgium
Telephone: (32)10 45 63 34, Fax: (32)10 45 63 67
E-mail: info@hamamatsu.be

Spanish Office

C. Argenters, 4 edif 2 Parque Tecnológico del Vallés
08290 Cerdanyola (Barcelona), Spain
Telephone: (34)93 582 44 30, Fax: (34)93 582 44 31
E-mail: infospain@hamamatsu.es

Germany, Denmark, The Netherlands, Poland:

HAMAMATSU PHOTONICS DEUTSCHLAND GmbH

Main Office
Arzbergerstr. 10, D-82211 Herrsching am Ammersee,
Germany
Telephone: (49)8152-375-0, Fax: (49)8152-265-8
E-mail: info@hamamatsu.de

Danish Office

Lautruphøj 1-3, DK-2750 Ballerup, Denmark
Telephone: (45)70 20 93 69, Fax: (45)44 20 99 10
Email: info@hamamatsu.dk

Netherlands Office

Transistorstraat 7, NL-1322 CJ Almere, The Netherlands
Telephone: (31)36-5405384, Fax: (31)36-5244948
E-mail: info@hamamatsu.nl

Poland Office

8 St. A. Boboli Str. PL-02-525 Warsaw, Poland
Telephone: (48)22-646-0016, Fax: (48)22-646-0018
E-mail: poland@hamamatsu.de

North Europe and CIS:

HAMAMATSU PHOTONICS NORDEN AB

Main Office
Torshamnsgatan 35 16440 Kista, Sweden
Telephone: (46)8-509 031 00, Fax: (46)8-509 031 01
E-mail: info@hamamatsu.se

Russian Office

11, Christoprudny Boulevard, Building 1, Office 114,
101000, Moscow, Russia
Telephone: (7)495 258 85 18, Fax: (7)495 258 85 19
E-mail: info@hamamatsu.ru

Italy:

HAMAMATSU PHOTONICS ITALIA S.r.l.

Main Office
Strada della Moia, 1 int. 6, 20020 Arese (Milano), Italy
Telephone: (39)02-93 58 17 33, Fax: (39)02-93 58 17 41
E-mail: info@hamamatsu.it

Rome Office

Viale Cesare Pavese, 435, 00144 Roma, Italy
Telephone: (39)06-50 51 34 54, Fax: (39)02-93 58 17 41
E-mail: inforoma@hamamatsu.it



Cat. No. KMPD0002E21
Nov. 2019 DN (2,000)
Printed in Japan