

TM

Photolonizer

ADVANCED ELECTROSTATIC REMOVER

"Particle Free" "Ozone Free" "No Air Flow"

Compact & Power supply compatible in world-wide & CE marking compliance

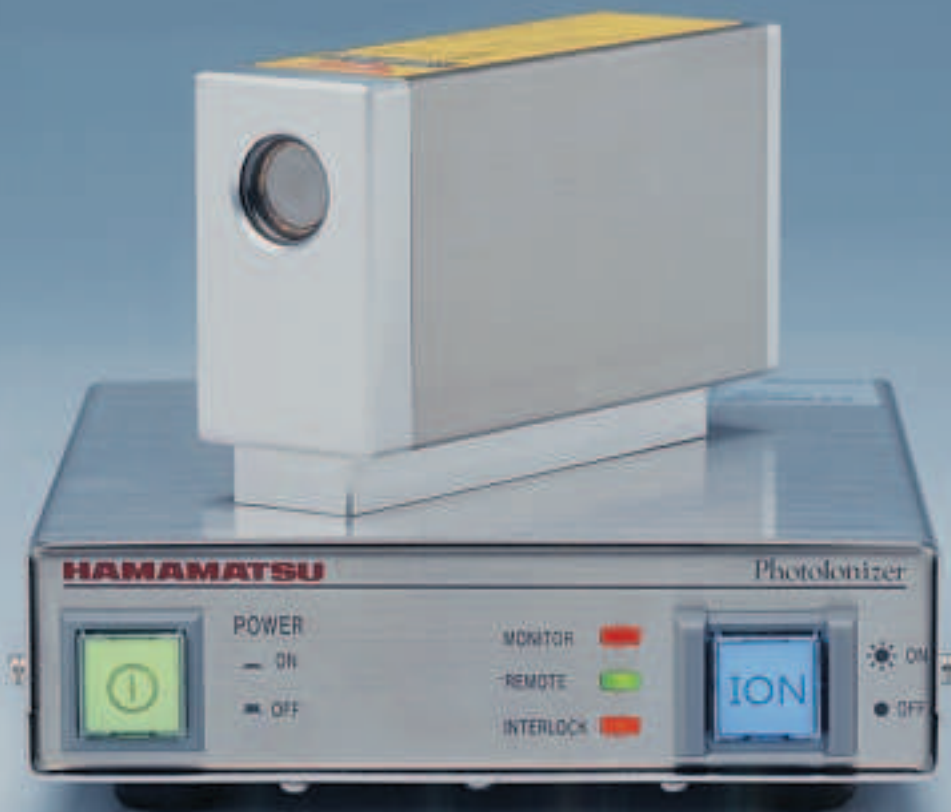

ACTUAL SIZE

HAMAMATSU

PHOTON IS OUR BUSINESS

Introducing a electrostatic charge removal using "PHOTOIONIZATION"!!



No air flow

Why! The soft X-ray exposure volume is equal to the ion generation volume.

Ion generation constantly occurs over the entire volume exposed to soft X-rays. Ions generated near the charged object serve to effectively remove the electrostatic charge, so there is no need for sending generated ions toward the object by an air flow. The Photoionizer also removes electrostatic charges from lightweight parts and powder.

High ion density

Why! Ions are generated over the entire exposed area.

In the corona discharge method, ions are mainly generated only near the electrodes. In the soft X-ray method, however, ions are generated over the entire volume exposed to these soft X-rays, yielding a drastic improvement in the removal of electrostatic charges.

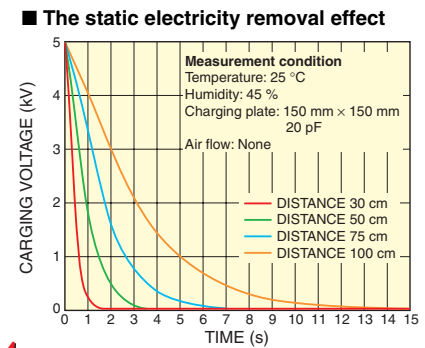

No overshoot

Why! Good ion balance eliminates overshoot.

If ion generation balance is poor, the positive or the negative ions will continuously increase in large quantities, resulting in "overshoot" (generation of static charges of opposite polarity). The Photoionizer, however, simultaneously generates the same amount of "positive" and "negative" ions in an ideal balance that prevents overshoot.

No cleaning of electrodes required

Why! The soft X-ray method is greatly superior to the conventional discharge method.

Corona discharge ionizers require frequent cleaning of the discharge electrodes since they become contaminated due to dust adhering to them and so reduce the effect of neutralizing static electricity. Photoionizers, in contrast, require no maintenance at all and ensure the excellent effect of removing static electricity over a long period of time.

The Photoionizer is a completely new type of electrostatic remover using "photoionization" for clean, easy, yet effective generation of ions. The Photoionizer provides big advantages over the corona discharge method which is generally used. The Photoionizer thoroughly ionizes molecules near the charged object so these ions in turn work effectively to remove electrostatic charges accumulated on the object. The Photoionizer is certain to be the next generation of electrostatic charge removers, since it now eliminates all the problems conventional electrostatic removers have in terms of object, speed, environment and reliability.

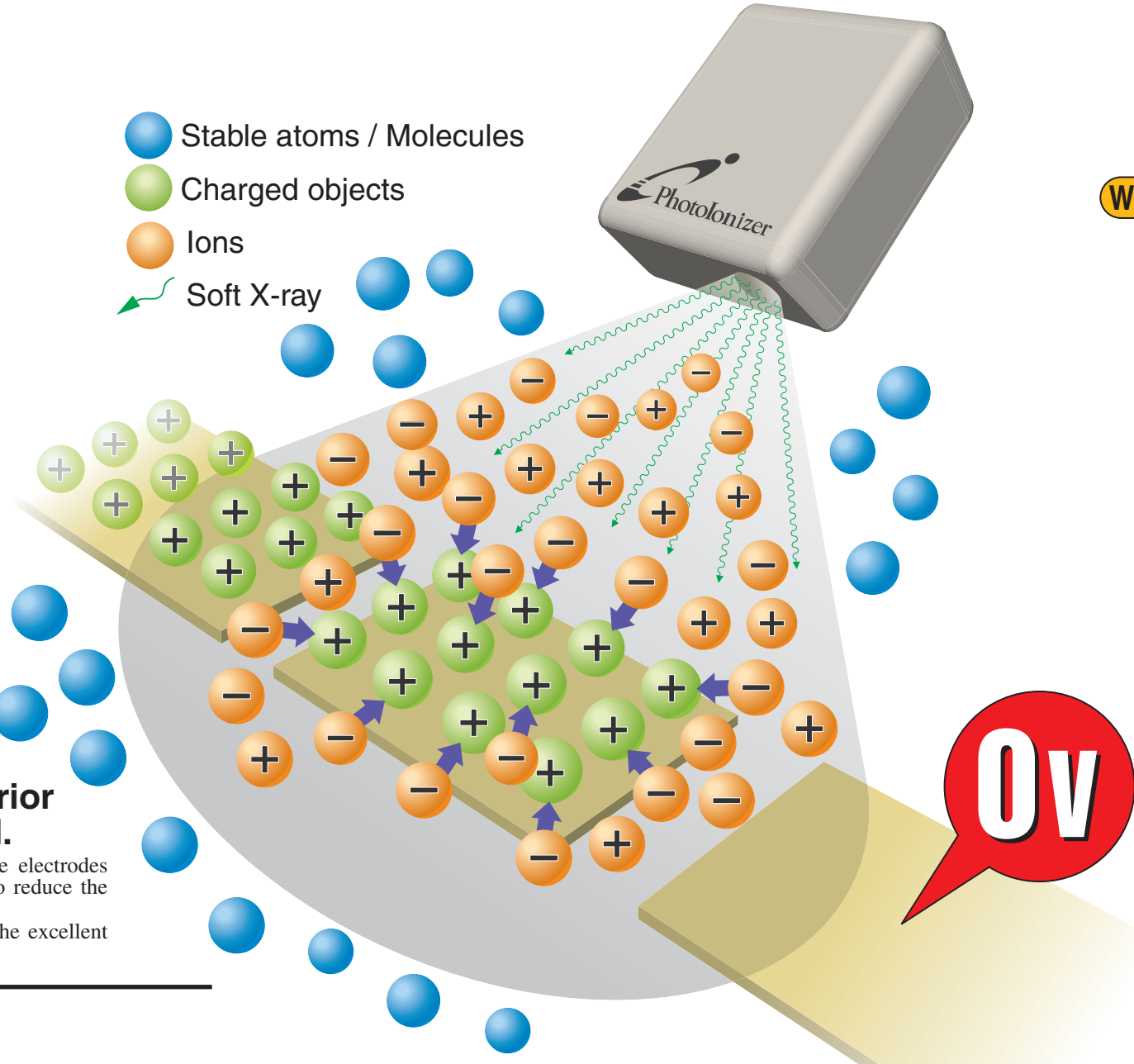

No ozone generation

Why! The soft X-ray method does not emit UV radiation.

Ozone is generated when the air is exposed to specific types of UV rays (approx. 10 eV). The blue light of a corona discharge contains this type of UV ray. The Photoionizer, in contrast, emits soft X-rays (3 keV to 9.5 keV) into the air to make an ionization. This ion generation method does not generate any ozone.

No dust particles and electromagnetic noise generation

Why! The soft X-ray method is greatly superior to the conventional discharge method.

<Dust Particles> In the corona discharge method, microparticles in the air are attracted to the electrodes and then diffuse back as dust particles.
<Electromagnetic Noise> Corona discharge accompanies the generation of electromagnetic noise.

As long as the discharge method is used, the above problems are inevitable. In contrast, the soft X-ray method used by the Photoionizer eliminates these problems.

OTHER FEATURES (L9490)

- **Compact: 30 mm × 50 mm × 96 mm (W × H × D) [head]**
About one-half the size of previous model. Installs even in narrow spaces.
- **Worldwide compatible power supply**
Accepts 100 V to 240 V AC.
- **External control**
15-pin D-sub connector. Operates in two remote modes and provides 4 types of external outputs.
- **CE marking compliance**
The Photoionizer complies with CE marking requirements therefore can be used in Europe.

A new era of safe and clean electrostatic removal has now begun. The Photoionizer has solved problems such as "generation of ozone and dust particles" and "overshoot due to poor ion balance" that often occur in the conventional method. The Photoionizer can also remove accumulated static charges even on high-speed moving objects and powders, which have been impossible up until now, by using the corona discharge method. Here are some problem solutions delivered by the Photoionizer - the advanced electrostatic remover.

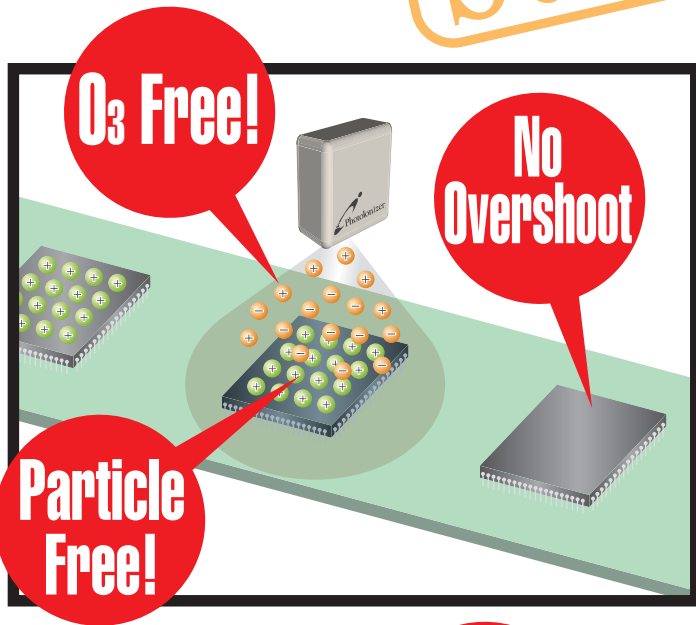

IC/LCD/PDP process lines

Problem On the IC, LCD and PDP process lines in a clean room, electrostatic charge may cause serious problem such as dust adhesion, dielectric breakdown and corrosion from ozone on peripheral equipment.

Solution The soft X-ray method does not cause diffusion of dust particles and provides a good ion balance that allows efficient removal of electrostatic charges without overshoot. Since this method generates no ozone, the electrostatic removal process is kept clean and safe.

TAPPC0122EA

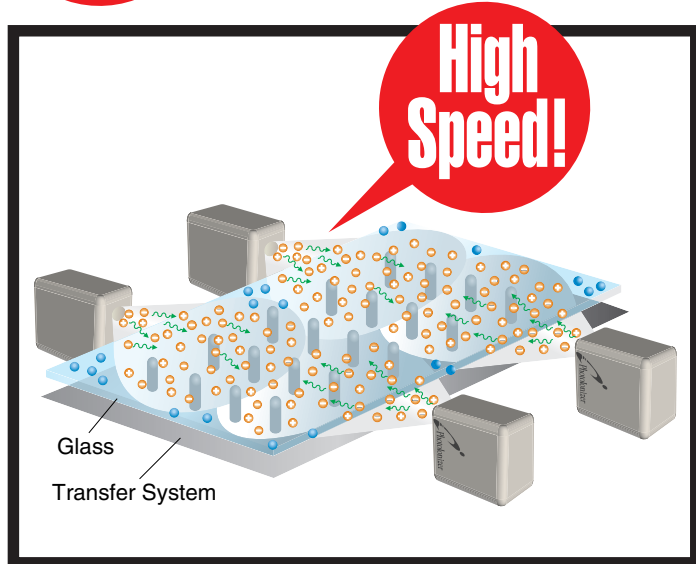

Large size glasses

Problem Electrostatic charges cause problems such as dust adhesion during the manufacturing process in clean room environments. If large size glasses are electrostatically charged, removing the electrostatic charges from them takes a great deal of time.

Solution In the soft X-ray method, ions are generated over the entire area exposed to X-rays so electrostatic charges can be quickly removed even from large glass surfaces.

TAPPC0123EA

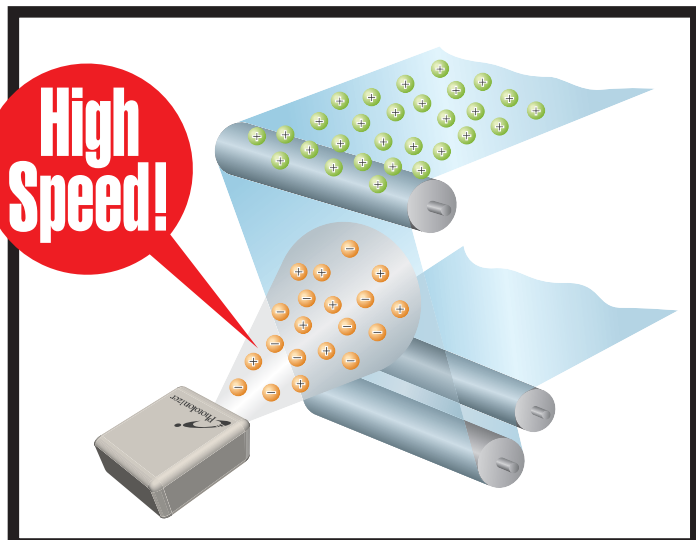

High-speed moving objects (films, printed matters, etc.)

Problem In film manufacturing and offset printing processes which usually move at high speed, electrostatic charges accumulated on the transfer cylinders may result in non-uniform printing or cause electric shocks to the human body.

Solution In the soft X-ray method, ions generated near the film surface serve to efficiently remove the electrostatic charges. Even though the film moves at high speed, the electrostatic charges can be reliably neutralized. In addition, ions generated by soft X-rays penetrating through the film, also neutralize the electrostatic charges on the reverse side of the film, so that the electrostatic removal effect is greatly improved.

TAPPC0124EA

CAUTION

The typical applications listed in this catalog are merely examples and do not constitute a guarantee that the device is suitable for commercial use or for a particular objective. Moreover, this catalog is not guarantee or a concession of intellectual assets.

PCB mounting, chip mounter

Problem Electronic components are continually being made smaller, thinner and lighter weight. Static electricity may cause these components to attract and stick to each other, or may lead to component delivery errors in the feeder.

Solution The soft X-ray method generates a high ion density which effectively neutralizes the electrostatic charges. Since air flow is not needed to transfer the generated ions, there is no problem with having to subject extremely thin and lightweight components, such as film spacers to the air flow.

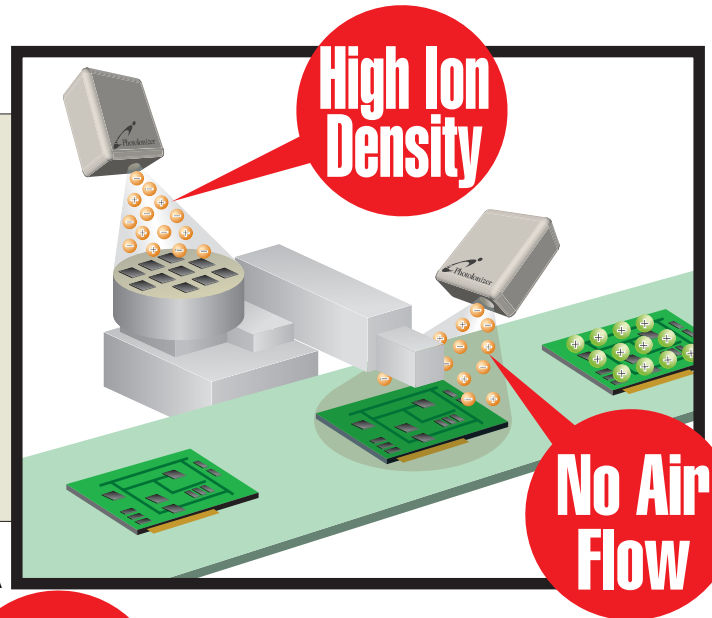

TAPPC0125EA

Packing of powdered products

Problem During the packing process for powdered medicine or food using film sheets, static electricity may cause powder to adhere to the dispenser nozzle or to the sealing surface of the sheet. This prevents the powder from being supplied correctly, resulting in packing errors in subsequent processes.

Solution The soft X-ray method does not require an air flow to transfer the generated ions, so the electrostatic charges can be removed without blowing away the powder. Further, because a wide area is exposed to the soft X-rays at the same time, the electrostatic charges on the film case can also be removed.

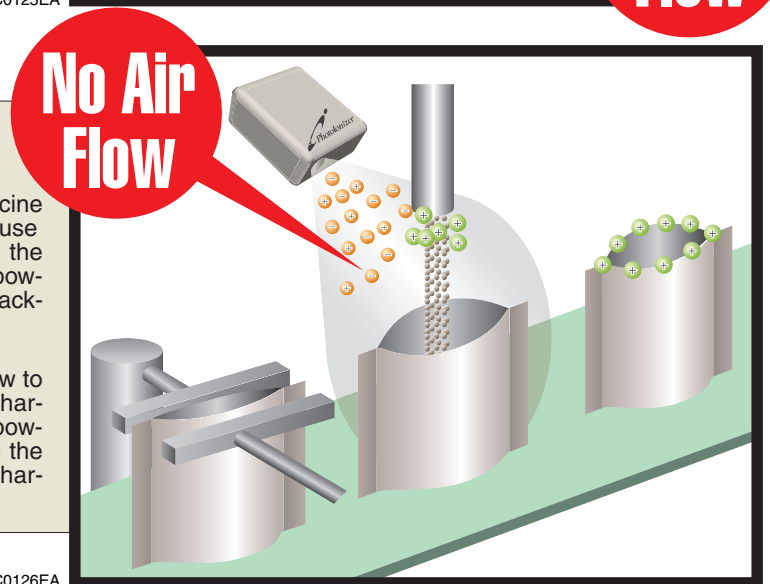

TAPPC0126EA

Plastic component molding process

Problem In the molding of plastic components, strong electrostatic charges occur when the component is separated from the die assembly. These charges cause dust and debris to adhere to the components.

Solution A high density of ions generated by the soft X-ray method can instantaneously eliminate such strong electrostatic charges. This method is also effective in removing electrostatic charges completely even from products with complex shapes.

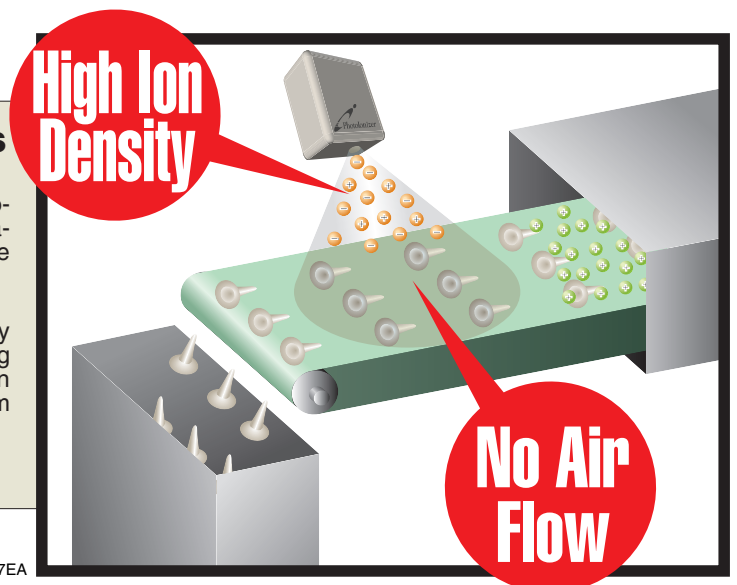

TAPPC0127EA

Principle of Photoionization

Ionization occurs near the charged object.

Object
plate or film

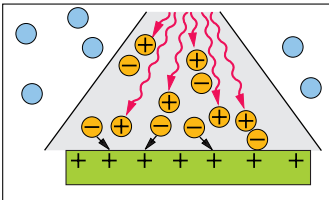

Ions generated near the charged object are easily attracted to it. Other generated ions return to their original stable state.

Object
Powder or dense solid

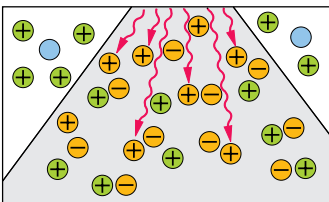

Ions are generated near each powder particle because ion generation occurs over the entire area exposed to the soft X-rays. So there is no need for a forced air flow.

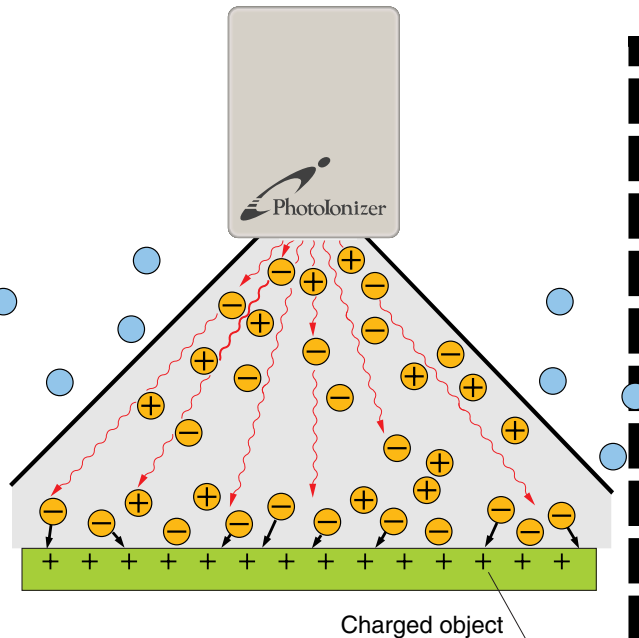

- ... Stable atoms or molecules
- ... Ions
- + ... Charge
- ~ ... Soft X-rays

"Photoionization" mechanism

Stable atom or molecule



Soft X-ray



Ejected electron e^-

Atom or molecule of positive polarity as one electron is ejected.



$e^- \rightarrow$ Stable atom or molecule

Ion



Both positive and negative ions are generated.

Ion

Photoionization ensures a good ion balance.

If ion balance is poor, too many positive or too many negative ions are continually present. This is what causes "overshoot".

ONLY A SIMPLE SHIELD IS NEEDED

Soft X-rays^{*1} can be shielded with a 1.3 mm thick aluminum plate to sufficiently safe levels.^{*2}

*1: Emitted soft X-ray energy is 3 keV to 9.5 keV.

*2: Below natural radiation levels

The Photoionizer requires soft X-ray shielding during operation. However, since the soft X-rays emitted from the PHOTOIONIZER, are weak (3 keV to 9.5 keV) following materials will completely prevent any exposure.

Shielding Material	Thickness(mm)
SUS 304	0.22
Aluminum Plate	1.3
Glass Plate	1.74

* Soft X-ray leakage can be checked with a survey meter. Please see page 13.

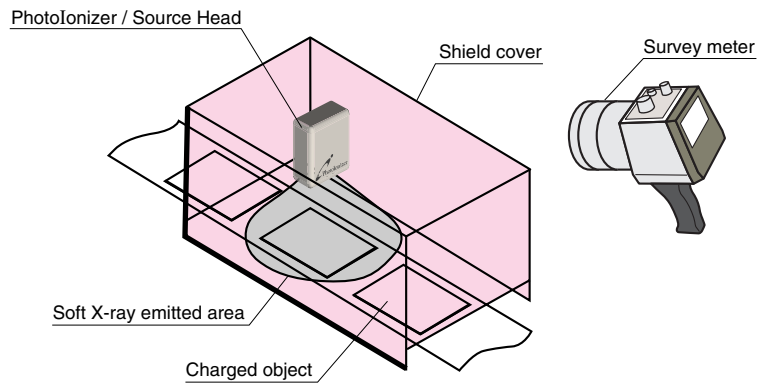

TAPPC0148EA

Soft X-ray shielding effects

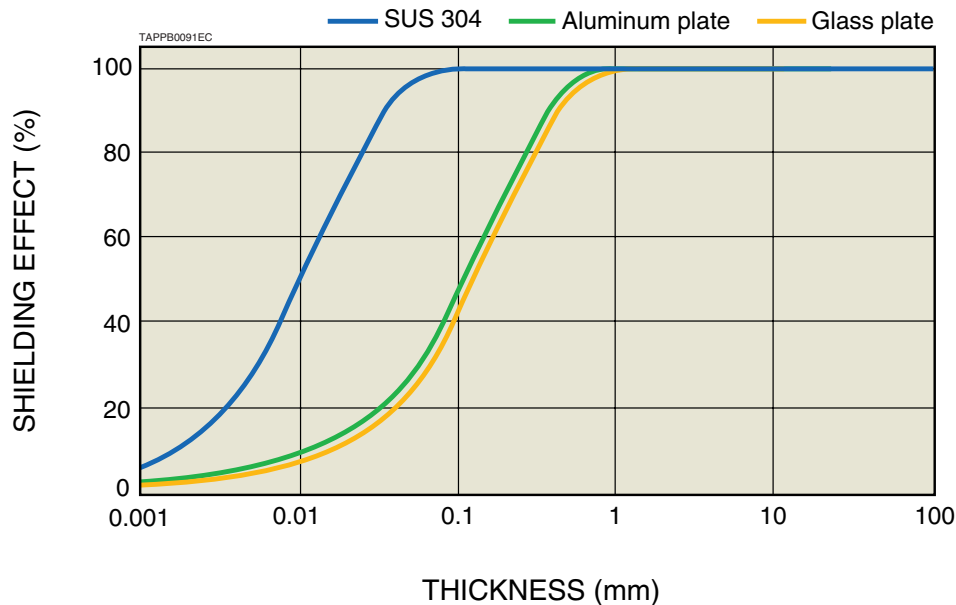

Cautions: 1) The distance between Photoionizer and survey meter is 10 cm. The plates is put between the 10 cm to measure shielding effect.

LINE UP

Photolonizer L9490



The Photoionizer is a completely new type of electrostatic remover using "photoionization" for clean, easy, yet effective generation of ions. The Photoionizer provides big advantages over the corona discharge method which is generally used.

The Photoionizer thoroughly ionizes molecules near the charged object so these ions in turn work effectively to remove electrostatic charges accumulated on the object.

The Photoionizer is certain to be the next generation of electrostatic charge removers, since it now eliminates all the problems conventional electrostatic removers have in terms of object, speed, environment and reliability.

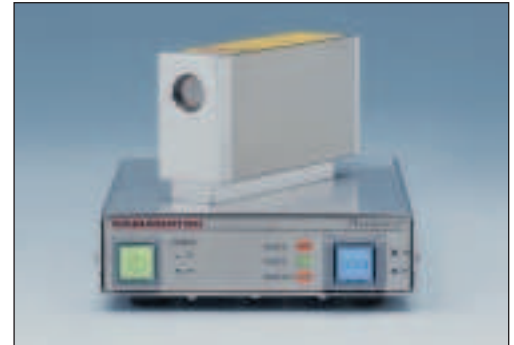

Dimensional Outline (Unit: mm)

● HEAD: L9491

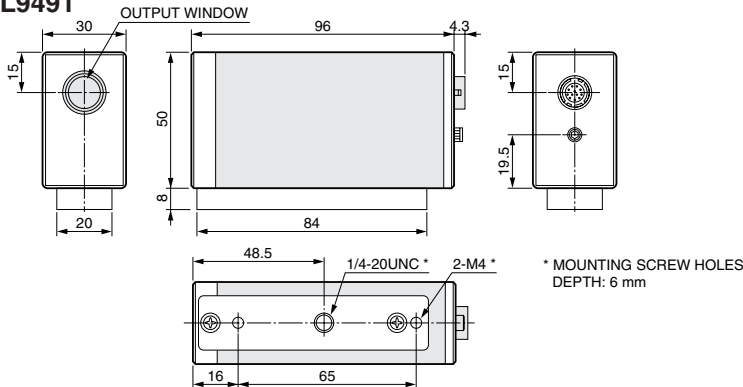

Shield material thickness

Shield material	Thickness (mm)
SUS 304	0.22
Aluminum plate	1.3
Glass plate	1.74

● CONTROLLER: C9492

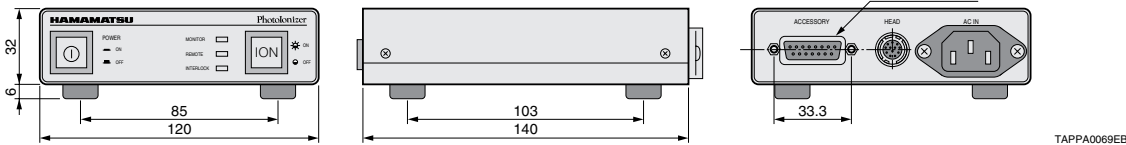

Photolonizer Operate by DC 24 V L9873



The L9873 Photoionizer operates on 24 V dc which is supplied from a power source in manufacturing equipment. Because the control system for manufacturing equipment can be used to directly control the L9873, there is no need for an additional controller that is usually required for other types of ionizers.

Dimensional Outline (Unit: mm)

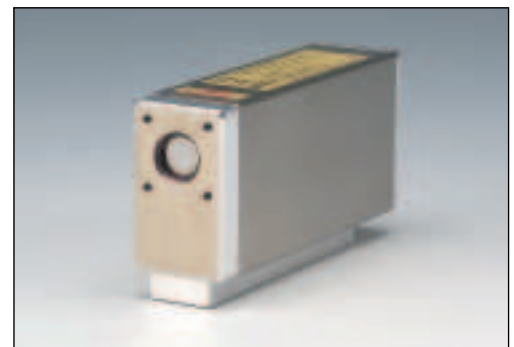
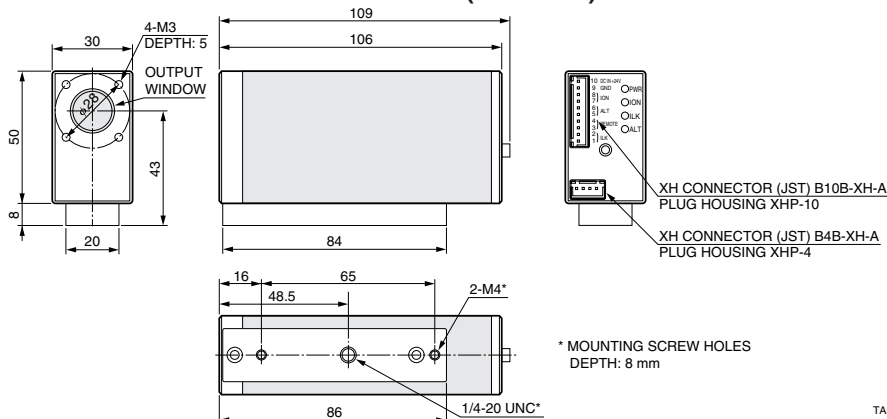

Photolonizer Compact Cube L11757

The L11757 low-energy photoionizer is a compact, electrostatic charge remover made even smaller than our previous photoionizers. Its compact head unit is designed to give extremely good positioning freedom during installation yet it still provides maintenance-free operation, zero dust generation, no electromagnetic noise emissions, no overshoot (generates no static charges of opposite polarity) and requires no air flow. The L11757 photoionizer can be installed near electrostatic generation points and also easily retrofitted to finished equipment.

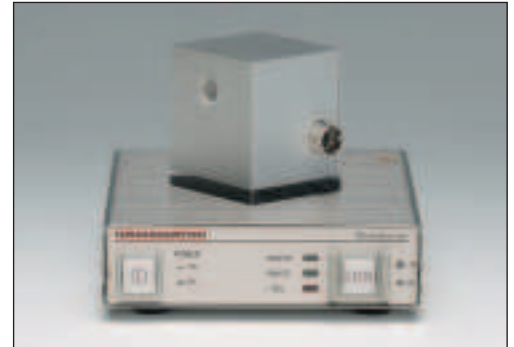

■ Features

● Easy to shield

X-ray shielding on the L11757 is easy and simple since the X-ray energy emitted from the L11757 is lowered to 4.9 keV from 9.5 keV of our previous models. By using a newly developed soft X-ray tube, we succeeded in increasing the ion generation efficiency to compensate for the decrease in ion concentration resulting from the lowered energy.

Shield material thickness

Shield material	Thickness (mm)
SUS 304	0.11
Aluminum plate	0.23
Acrylic plate	3.3

■ Electrostatic Charge Removal Effect

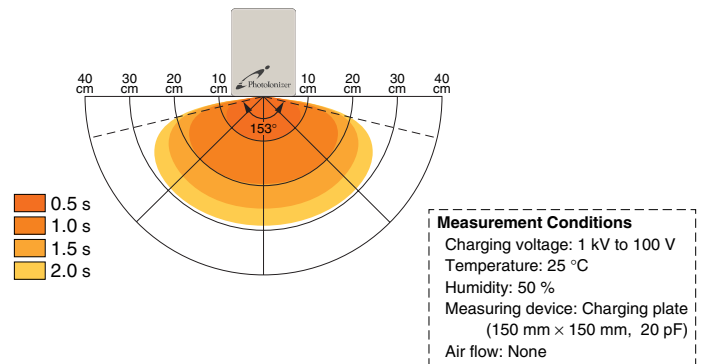

■ Dimensional Outline (Unit: mm)

● HEAD: L11758

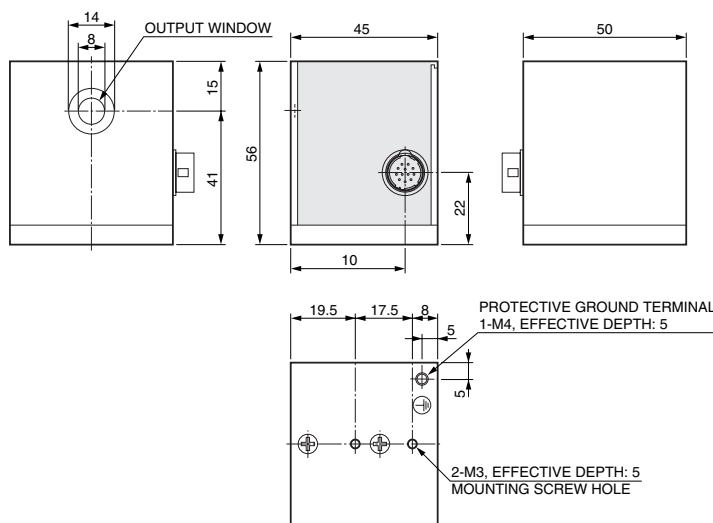

● CONTROLLER: C11760

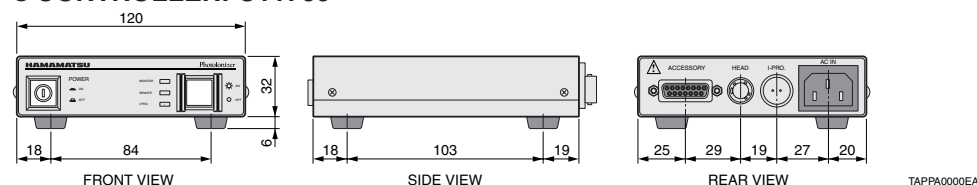

LINE UP

Explosion-proof* Photolonizer L9499 * Japan standard only

Semiconductor and LC (liquid crystal) manufacturing processes face serious problems from electrostatic charges that cause contaminants to adhere or penetrate into the product or that cause dielectric breakdown of semiconductor devices. These manufacturing processes also often use organic solvents that have drastically increased the need for safe and explosion-proof designs. The Photoionizer electrostatic removers utilize "photoionization" that generates ions by using weak X-rays. This ion generation method does not have the hazard of sparks or ignition that may occur in conventional ionizer devices. The L9499 explosion-proof Photoionizer was designed so that the enclosure structure and cable couplings meet domestic explosion-proof standards*. Like other previously marketed Photoionizers, there are no problems with ozone generation or dust particles from the electrode, ensuring safe, clean removal of electrostatic charges.



▲ Left: Head unit, Right: Controller unit
Model certification No. Head unit: No. TC17213
Controller unit: No. TC17206

* Test / Certification: Technology Institution of Industrial Society (Japan)

■ Coverage by This Device: Exd II BT5 *1 (covered range)

Explosive Gas Categories *3	Temperature Class *2	T1	T2	T3	T4	T5	T6
	Ignition Temperature	Over than 450 °C	Over than 300 °C	Over than 200 °C	Over than 135 °C	Over than 100 °C	Over than 85 °C
A		Ammonia Carbon monoxide Ethane Toluene Propane Methane Acetone	Ethanol 2-Butanol Butane Acetylacetone Polyvinyl chloride Methanol Isopropyl alcohol	Hexane Gasoline Kerosine Pentane	Acetaldehyde Trimethylamine		Ethyl nitrite
B		Hydrogen cyanide Acrylonitrile Coal gas	Furan Methyl ethyl ketone Ethyl acrylate Ethylene	Dimethyl ether Cyclonhexane Isoprene			
C		Hydrogen	Acetylene			Carbon disulphide	Ethyl nitrate

*1) Explosion-proof enclosure: d (flameproof enclosure or explosion-proof enclosure)
Explosion-proof electrical equipment: II (items used in factories other than within mining operation sites or in hazardous locations at commercial operations)

Gas or steam categories: A to B Temperature class: T1 to T5 range (ignition temperature of 100 °C or higher) Hazardous location*4: Type 1 location

*2) Applies to gases or steam for which the larger the number, the greater the hazard of igniting a fire at a low temperature.

*3) Indicates highly hazardous gases or steam in the order of A < B < C.

*4) Type 1 location: Location where a hazardous atmosphere is present consecutively or for long periods of time during a normal state.

Type 2 location: Location where a hazardous atmosphere might occur during an abnormal state.

■ Dimensional Outline (Unit: mm)

● HEAD: L9497

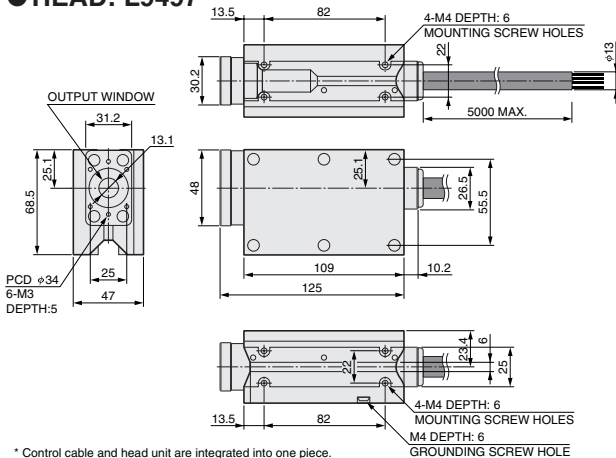

* Control cable and head unit are integrated into one piece.

TAPPA0087EA

● CONTROLLER: C9498

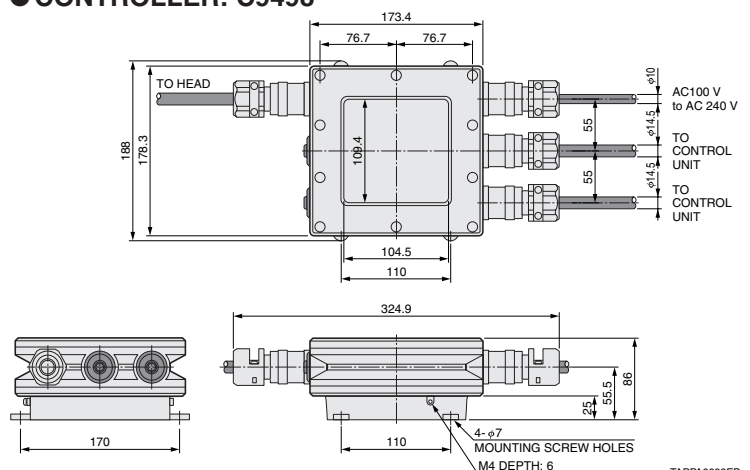

TAPPA0088EB

Multiple Four Head Type Photolonizer Controller C9991

The controller C9991 can operate 4-Photoionizer head in parallel. It should be convenient for the customer who likes to make synchronization.



▲ Right: C9991

Dimensional Outline (Unit: mm)

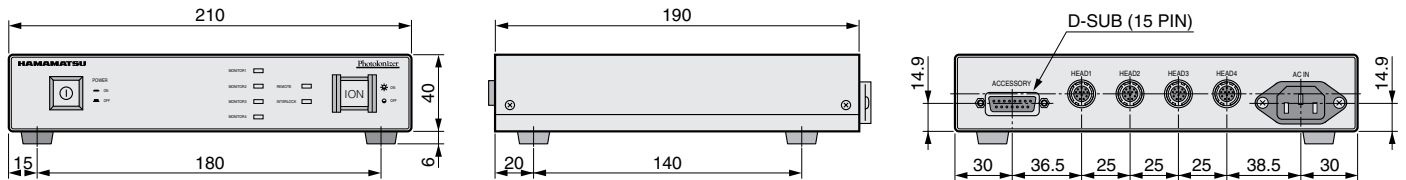

TAPPA0081EC

CONNECTING EXAMPLE

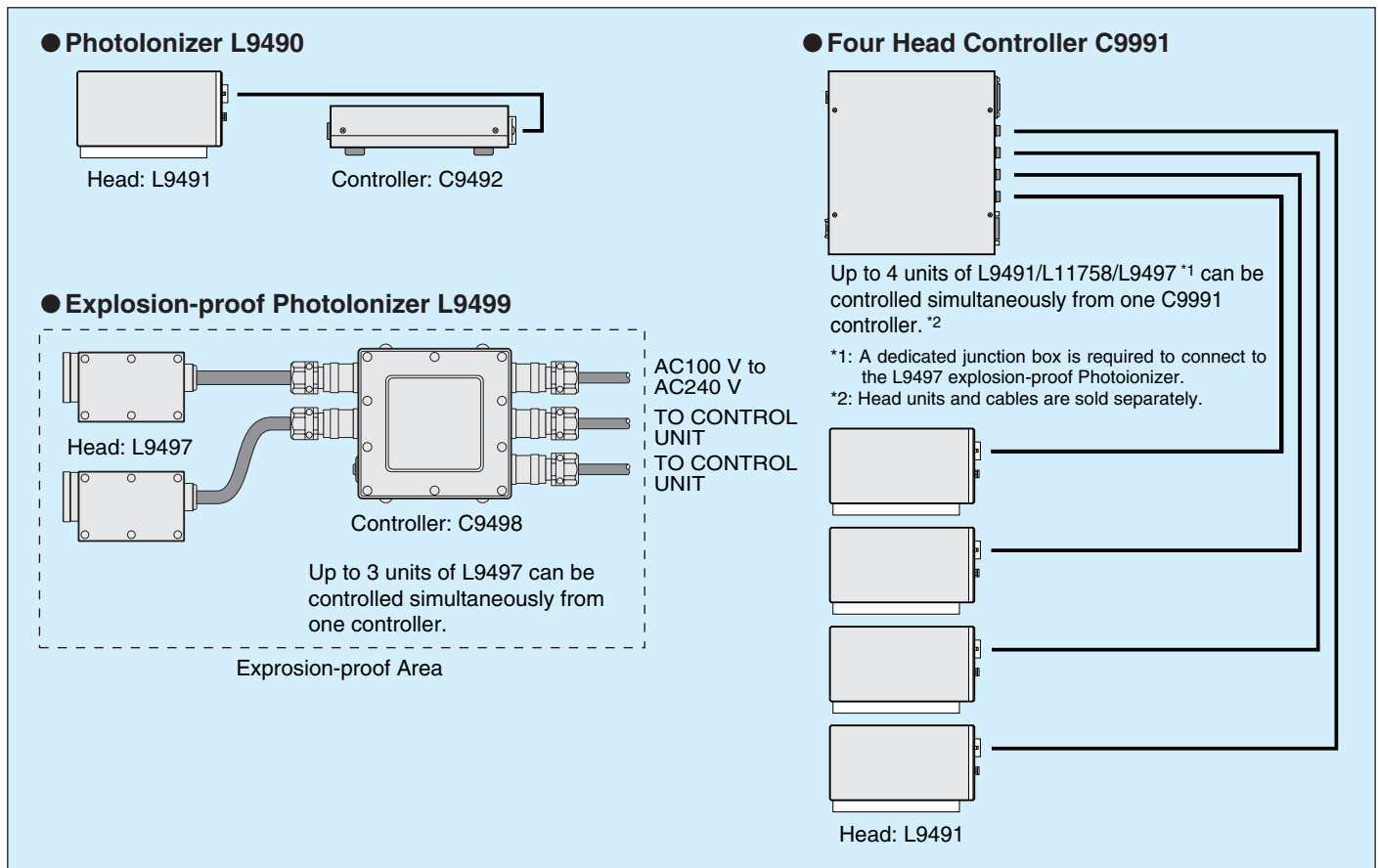

HOW TO USE!

FUNCTION AND PERFORMANCE



In what area can the electrostatic charge be removed?



The electrostatic charges can be removed everywhere the soft X-ray is exposed.

The soft X-rays are emitted from the output window of the PHOTOIONIZER in a conical shape with an angle of 130 degrees (L9490). The ion generation volume is nearly equivalent to the X-ray exposure volume, so electrostatic charges within this volume can be removed. Actually, the ions produced near the object neutralize the electrostatics charge.



Up to what distance does the electrostatic charge removal effect extend?



The distance from head, to the charged object, should be within one meter. (Except L11757)

The electrostatic charge removal becomes stronger as the output window of the PHOTOIONIZER is brought closer to the object. In other words, the effect decreases as the distance from the output window to the object increases. This is, because the soft X-rays become weaker and the ion generation drops, as the distance increases. The figure below shows contours of the electrostatic charge removal time for different distances from the head. While the distance from the head to the object should be within one meter, the optimum installation location takes into account the size of the charged object or the area from which the electrostatic charges must be removed.

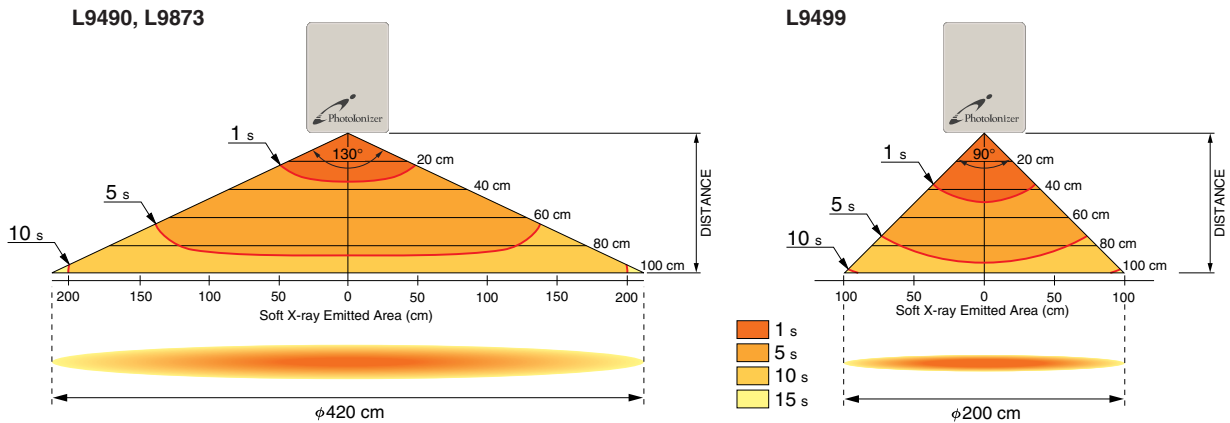

Measurement Conditions

Charging voltage: 1 kV to 100 V
 Temperature: 25 °C
 Humidity: 50 %

Measuring device: Charging plate
 (150 mm × 150 mm, 20 pF)
 Air flow: None

* Performance for removing or neutralizing static electricity depends on how objects are placed and what material they are made of, as well as the ambient environment (temperature, humidity, etc.).



Is it necessary to use air flow to efficiently remove the electrostatic charge with soft X-rays?



No, it is not.

The PHOTOIONIZER does not need air flow as is required in the conventional corona discharge ionizer. This eliminates problems such as adhesion of dust particles and also allows effective use in confined areas where the air flow can not penetrate.



How long does the electrostatic removal effect last?



Once removing electrostatic charges, its effect last as long as the object is stationary.

Since the PHOTOIONIZER ensures a good ion balance, the neutralized state at zero volts can be maintained as long as the object is stationary. However, if additional electrostatic charging phenomena such as friction, contact or movement are applied to the object, the neutral condition may not be maintained.



Does the PHOTOIONIZER have remote ON/OFF control capability?



Yes, it has.

It is possible to control the soft X-ray irradiation (ON/OFF) using a remote control terminal.



How fast are soft X-rays emitted in response to ON/OFF switching?



Approximately 0.1 seconds.

The PHOTOIONIZER emits soft X-rays generating ions 0.1 seconds after turning on the controller "ION" switch. This X-ray irradiation also stops 0.1 seconds after turning off the "ION" switch. There are no residual X-rays.



How frequently should maintenance be performed on the PHOTOIONIZER?



There is no need for daily maintenance.

The PHOTOIONIZER has a high-performance stabilized circuit that ensures the device performance for a long time.



What is the approximate life time of the PHOTOIONIZER?



Mean time to failure 14800 hours.

Mean time to failure 14800 hours. The accumulated operating hours are displayed on the indicator of the control unit.

* PHOTOIONIZER is warranted for one year from date of delivery.



Can the PHOTOIONIZER be used for charged objects under reduced pressure such as, inside a vacuum chamber?



We recommend to use an ultra-violet light-type electrostatic remover.

Efficiency of the electrostatic charge removal effect of soft X-ray, drops sharply when the surrounding air pressure is reduced. In such environments, we recommended the ultra-violet light-type electrostatic remover.

HOW TO USE!

SAFETY



Does any reflection or scattering occur in the soft X-ray beam?



Only slight reflection or scattering occurs in the surrounding air.

Place the shield, not only at the output side but, all around the part.



What is the wavelength of the soft X-ray emitted by the PHOTOIONIZER?



Peak wavelength is 0.2 nm and the energy is 3 keV to 9.5 keV.

The PHOTOIONIZER emits soft X-rays at peak wavelength of 0.2 nm¹⁾. These soft X-rays have little ability to penetrate objects and are mostly absorbed by air or moisture.

(Note 1: See "Terminology")



How strong are the soft X-ray emissions?



The X-ray dose at a distance of one meter from the output window of the PHOTOIONIZER is 15 mSv/h²⁾.

This is about 1/5000 of X-ray levels used for medical radiography.

(Note 2: See "Terminology")



What happens if one is directly exposed to soft X-rays?



Direct exposure to soft X-rays can cause skin or eye burns similar to burns received from intense ultraviolet rays.

Always install the PHOTOIONIZER head in an X-ray shielded cabinet or other shielded location where the body is not directly exposed to X-rays.



How should soft X-ray leakage from the shield be checked?



We recommend survey meters. Please contact us for more information.

Soft X-ray leakage can be checked with a survey meter. In Japan, the PHOTOIONIZER is in compliance with health and safety regulations legally enforced to prevent physical problems due to ionizing radiation. X-ray leakage from the shield must be measured to ensure health and safety. To measure soft X-ray leakage, we recommend using the model ICS-323CV1 survey meter (manufactured by Hitachi Aloka Medical, Ltd.) that is supplied with a test sheet issued by the JQA (Japan Quality Assurance Organization). Since the ICS-323CV1 is calibrated it also offers a good traceability as measurement equipment.

Survey meter ICS-323CV1
(Hitachi Aloka Medical, Ltd.)





Are there any equipment registration required before using the PHOTOIONIZER?



Yes, there are possibilities. Please comply with local safety and health regulations.

The PHOTOIONIZER might have to be registered before use and safety testing is usually required by local regulations in your area that deal with radiation or X-ray hazards. Consult our local sales office to find out more about these registration requirements.



Do the soft X-rays cause changes to or have adverse effect on the charged objects?



No, there are no changes nor adverse effects.

Under normal operation, no problems will occur. If an object is continuously exposed to soft x-rays emitted from the PHOTOIONIZER for several days, some deterioration may occur. The PHOTOIONIZER does not utilize or produce radioactive materials. The PHOTOIONIZER has been used in semiconductor and liquid crystal process lines. No problems with reliability or deterioration have occurred.



Is ozone generated by the soft X-ray exposure?



There is no generation of ozone with the PHOTOIONIZER.

The principle of the PHOTOIONIZER is quite different from the corona discharge ionizer which generates ozone and causes adverse effects on the surroundings (such as producing corrosion on objects and peripheral equipment). The PHOTOIONIZER, however, has no such problems.



When necessary, how should disposal of the PHOTOIONIZER be performed?



Please follow the applicable regulations regarding disposal of hazardous materials and industrial wastes in your country, state, region or province.

The material in the PHOTOIONIZER output window contains beryllium.

Terminology

Note 1: nm (nanometer) are a unit of length.
1 nm=10⁻⁹ m (one billionth of a meter).

Note 2: Sv or Sieverts are units of absorbed dose of radiation in a body.
Sv/h indicates the absorbed dose per hour.

■ Specifications

Parameter		L9490	L9873	L9499	L11757
Ionization Method		Soft X-ray exposure			
Ionization Source		Soft X-ray tube			
Soft X-ray Tube	Tube Voltage (DC)	9.5 kV			4.9 kV
	Tube Current	150 μ A			200 μ A
	Beam Angle	130 °	130 °	90 °	153 °
Input Voltage		AC100 V to AC240 V (50 Hz / 60 Hz)	DC24 V	AC100 V to AC240 V (50 Hz / 60 Hz)	AC100 V to AC240 V (50 Hz / 60 Hz)
Power Consumption		11 W Max.	7 W Max.	33 W Max.	7 W Max.
Weight	Head	0.35 kg	0.4 kg	3.2 kg	0.25 kg
	Controller	0.5 kg	—	6.3 kg	0.5 kg
Operating Ambient Temperature		0 °C to +40 °C			
Storage Temperature		-10 °C to +60 °C			
Operating Ambient Humidity		Below 60 %			
Storage Humidity		Below 80 %			
CE		yes	yes	no	yes
Use of four head controller C9991		yes	no	yes *	yes

* A dedicated junction box is required for use.

⚠ SAFETY PRECAUTIONS

- Soft X-rays emitted from this product are harmful to human health. Take adequate precautions to avoid X-ray exposure.
- When using this product, always install the head inside an X-ray shielded cabinet or other shielded location with utilizing interlock mechanism.

⚠ EXPLOSION-PROOF STRUCTURE

- Explosion-proof Photoionizer conforms to the Explosion-proof enclosure Exd II BT5 (Explosion-proof enclosure standards for electrical equipment). Be sure to use it in a relevant explosion-proof area (gas atmosphere, hazardous location, etc.).

⚠ PRECAUTIONS TO USE

- These products are high precision device. Handle it carefully so as not to apply shocks and vibrations.
- The internal ion generator (soft X-ray tube) is a vacuum tube consisting of a glass envelope that may crack or rupture if subjected to shock. Do not apply strong shocks or vibrations to these products.
- These products were designed for natural air cooling. Do not install it inside a small, air-tight container or locations where the generated heat cannot dissipate.
- To install the head, always use the mounting screw holes in the metal base on the bottom of the head.
- Except for the explosion-proof Photoionizer, do not use Photoionizers in an atmosphere containing organic solvents and/or flammable gases.
- If these products does not operate correctly, turn the power off and check the cable connections. Then turn the power on again and recheck operation. If still inoperative then this product might be defective. Contact us for proper handling or repair.

LEGAL REGULATIONS INVOLVING THIS PRODUCT

These products must be used in compliance with health and safety regulations enforced to prevent the bodily harm caused by ionizing radiation. Users of these products must be familiar with the applicable laws that regulate use of X-ray emission devices. For more details, refer to international or domestic laws and regulations on ionizing radiation and comply with the required procedures listed there.

WARRANTY PERIOD

These device are guaranteed for one year from date of delivery, whichever comes first.
The warranty extends only to replacement of the products. The warranty does not cover damage due to misuse or natural calamity.

* 23 patents (Japan, Taiwan, China, Korea, U.S.A. etc.)

Subject to local technical requirements and regulations, availability of products included in this promotional material may vary. Please consult with our sales office.
Information furnished by HAMAMATSU is believed to be reliable. However, no responsibility is assumed for possible inaccuracies or omissions. Specifications are subject to change without notice. No patent rights are granted to any of the circuits described herein. ©2012 Hamamatsu Photonics K.K.

HAMAMATSU PHOTONICS K.K. www.hamamatsu.com

HAMAMATSU PHOTONICS K.K., Electron Tube Division

314-5, Shimokanzo, Iwata City, Shizuoka Pref., 438-0193, Japan, Telephone: (81)539/62-5248, Fax: (81)539/62-2205

U.S.A.: Hamamatsu Corporation: 360 Foothill Road, P. O. Box 6910, Bridgewater, N.J. 08807-0910, U.S.A., Telephone: (1)908-231-0960, Fax: (1)908-231-1218 E-mail: usa@hamamatsu.com

Germany: Hamamatsu Photonics Deutschland GmbH: Arzbergerstr. 10, D-82211 Herrsching am Ammersee, Germany, Telephone: (49)8152-375-0, Fax: (49)8152-2658 E-mail: info@hamamatsu.de

France: Hamamatsu Photonics France S.A.R.L.: 19, Rue du Saule Trapu, Parc du Moulin de Massy, 91882 Massy Cedex, France, Telephone: (33)1 69 53 71 00, Fax: (33)1 69 53 71 10 E-mail: infos@hamamatsu.fr

United Kingdom: Hamamatsu Photonics UK Limited: 2 Howard Court, 10 Tewin Road Welwyn Garden City Hertfordshire AL7 1BW, United Kingdom, Telephone: 44(0)1707-294888, Fax: 44(0)1707-325777 E-mail: info@hamamatsu.co.uk

North Europe: Hamamatsu Photonics Norden AB: Smidesvägen 12, SE-171-41 SOLNA, Sweden, Telephone: (46)8-509-031-00, Fax: (46)8-509-031-01 E-mail: info@hamamatsu.se

Italy: Hamamatsu Photonics Italia: S.R.L.: Strada della Moia, 1/E, 20020 Arese, (Milano), Italy, Telephone: (39)02-935 81 733, Fax: (39)02-935 81 741 E-mail: info@hamamatsu.it

China: HAMAMATSU PHOTONICS (CHINA) Co., Ltd.: 1201 Tower B, Jianning Center, No.27 Dongshanhuan Beilu, Chaoyang District, Beijing 100020, China, Telephone: (86)10-6586-6006, Fax: (86)10-6586-2866 E-mail: hpc@hamamatsu.com.cn

TAPP1073E02
MAY 2012 IP