

Digital CCD Camera C9300-201 Instruction Manual

Thank you for your purchase.







 CAUTION	<ul style="list-style-type: none">• Follow the safety precautions in Chapter 1 in order to avoid personal injury and damage to property when using this camera. The manual describes the correct method of handling C9300-201 camera and provides cautions in order to avoid accidents. Read this manual carefully beforehand use the camera correctly.• After reading the manual, store it in a location where you can refer to it at any time.
--	--

Ver.1.2
April 2007

HAMAMATSU PHOTONICS K.K.

1. SAFETY PRECAUTIONS

We have classified the warnings symbols that appear in this instruction manual and on the camera as follows for your convenience. Make sure that you fully understand them and obey the instructions they contain.

 WARNING	Improper handling of the camera without observing these warnings could lead to serious injury to the user and even death.
 CAUTION	Improper handling of the camera without observing these cautions could lead to personal injury to the user or damage to property.
 Note	This symbol indicates a note to help you get the best performance from the camera. Read the contents of the note carefully to ensure correct and safe use. Failure to observe one of these notes might impair the performance of the camera.
	This symbol indicates a cautionary item that should be obeyed when handling the camera. Read the contents carefully to ensure correct and safe use.
	This symbol indicates an action that is forbidden. Read the contents carefully and be sure to obey them.
	This symbol indicates a compulsory action or instruction. Read the contents carefully and be sure to obey them.

 **WARNING**



Power Supply

Use the camera with the voltage indicated on the rating. Using a different voltage can damage the camera and lead to fire or electric shock.



Cables

Be careful not to place heavy objects on cables or bend it excessively. Doing so can damage the cable and lead to fire or electric shock.



Do not attempt to dismantle or modify the camera

Doing so can also lead to damage and even injury, as some internal components become very hot. Only touch parts as indicated in this manual.



Do not allow foreign objects such as combustible substances, metal objects or water to get inside the camera. They can damage the camera and lead to fire or electric shock.



If an abnormality occurs,

such as the image suddenly disappearing or a strange noise, smell or see smoke coming from the camera, turn the power off immediately and contact Hamamatsu subsidiary or local distributor. In case the repair is needed, it should be always treated at Hamamatsu side.

 **CAUTION****Connecting and disconnecting cables**

Always turn off the power before connecting and disconnecting cables.

**Fixing the camera**

When fitting the camera to a tripod, for example, use the screw (1/4-20UNC) in the center of a camera mount. Be careful that the fitting screw does not enter more than 5 mm from the surface of the mount. Screwing it in excessively can impair normal operation.

**Shipping precautions**

When transporting the camera by truck, ship, airplane, etc., wrap it securely in packaging material or something similar.

**Strong Impact**

Do not subject the camera to strong shocks by dropping it, for example. Doing so can damage the camera.

**Disposal**

When disposing of the system, take appropriate measures in compliance with applicable regulations regarding waste disposal and correctly dispose of it yourself, or entrust disposal to a licensed industrial waste disposal company. In any case, be sure to comply with the regulations in your country, state, region or province to ensure the system is disposed of legally and correctly.

2. CHECK THE CONTENTS OF PACKAGE

When you open the package, check that the following items are included before use. If the contents are incorrect, insufficient or damaged in any way, contact Hamamatsu subsidiary or local distributor without attempting to operate the camera.

Digital CCD camera	1
Lens mount cap (attached to the camera)	1
C9300-201 instruction manual (this booklet)	1

[Option]

AC adapter (Accessories: Power supply cord)	A3472-06
Camera cable	A3194-00 (2 m)
	A3194-01 (5 m)
	A3194-02 (10 m)
	A3194-03 (25 m)
CameraLink interface cable	A9262-05 (5 m)
	A9262-10 (10 m)

Note

- The cable listed in option is highly recommended for use with the camera. The camera system may not confirm to CE marking regulation if other type of cable is used with.

3. INSTALLATION



Do not use or store the camera these locations.

- Where the ambient temperature may fall below 0 °C or rise above 40 °C
- Where the temperature fluctuates sharply
- In direct sunlight, or near a source of heat
- Where the humidity exceeds 70 %, or where it is exposed to water
- Near sources generating strong magnetic or electrical fields
- Where there is vibration
- Where it comes in contact with corrosive gases (chlorine, fluorine, etc.)
- Dusty locations

Contents

1. SAFETY PRECAUTIONS	1
2. CHECK THE CONTENTS OF PACKAGE	4
3. INSTALLATION	4
4. OVERVIEW	7
5. FEATURES	7
6. NAME AND FUNCTION OF THE PARTS	8
6-1 CAMERA.....	8
7. CONNECTING CABLES	10
8. OPERATION	11
8-1 PREPARATION FOR IMAGING.....	11
8-2 IMAGING.....	11
8-3 END OF IMAGING.....	11
9. IMAGE ACQUISITION	12
9-1 THEORY OF CCD.....	12
9-2 OVERVIEW OF CAMERA MODES.....	13
9-3 DETAIL OF CAMERA MODES.....	13
9-3-1 DIGITAL OUTPUT BIT COUNT.....	13
9-3-2 CCD OUTPUT MODE.....	14
9-3-3 DETAIL ON CCD SCANNING (SCAN MODE).....	14
9-3-4 EXPOSURE TIME SETTING.....	15
9-3-5 FAST REPETITION MODE.....	23
10. COMMAND SPECIFICATIONS	26
10-1 TRANSMISSION INTERFACE.....	26
10-2 COMMAND FORMAT.....	26
10-3 CAMERA RESPONSE TO COMMANDS.....	26
10-4 OVERVIEW OF COMMANDS.....	28
10-5 COMMAND INITIAL SETTING.....	30
10-6 DETAIL OF COMMANDS.....	31
11. PRECAUTIONS WHEN USING THE CCD	36
12. MAINTENANCE	37
12-1 CARE.....	37
13. TROUBLESHOOTING CHECKLIST	38
13-1 IMAGE NOT TRANSFERRED.....	38
13-2 ALTHOUGH IMAGES ARE TRANSFERRED.....	38
14. SPECIFICATIONS	39
14-1 CAMERA SPECIFICATIONS.....	39
14-2 SPECTRAL RESPONSE CHARACTERISTICS.....	40
14-3 CAMERALINK INTERFACE SPECIFICATIONS.....	41
14-3-1 CAMERALINK INTERFACE.....	41

14-3-2	TIMING I/O CONNECTOR PIN ASSIGNMENTS [TIMING I/O]	43
14-3-3	CAMERA CONNECTOR PIN ASSIGNMENT [POWER]	43
14-4	IMAGE DATA OUTPUT TIMING SPECIFICATIONS	44
15.	DIMENSIONAL OUTLINES	45
15-1	CAMERA	45
16.	WARRANTY	46
17.	CONTACT INFORMATION	47

4. OVERVIEW

The C9300-201 is a small size and high performance digital CCD camera with 12 bit output. The camera meets the demand in the industrial/scientific field for high accuracy and high quality imaging. And it is based on CameraLink and can output the image data into the CameraLink board on market.

5. FEATURES

(1) High speed

Equipped with a high-speed solid-state imaging device having 640 (horizontal) × 480 (vertical) pixels. Pixels are square, facilitating image processing for measurement purposes.

(2) Dual readout

The CCD has dual readout amplifiers for the half left side area of the CCD and right side. (When using single readout mode, only left side amplifier is used.) So you can obtain the image data with quite high frame rate.

Note

- Dual readout mode uses two-separated readout Amp whose performance is not perfectly same. Due to the readout Amp characteristics variation, you may see little intensity gap between right side and left side in one image even though the fine adjustment is done at factory before shipping. Single readout mode is recommended to achieve the best possible image quality.

(3) Digital output

Image signals are converted from analog to digital in the camera and output externally as 12 bit digital data. (Transmission line length: max. 10 m, based on CameraLink.)

(4) Small Head

Small, lightweight camera allows for a construction that is extremely easy to use in such applications as microscopic measurement and spectrometry.

(5) Lens mount

C-mount used for the lens mount.

6. NAME AND FUNCTION OF THE PARTS

6-1 CAMERA

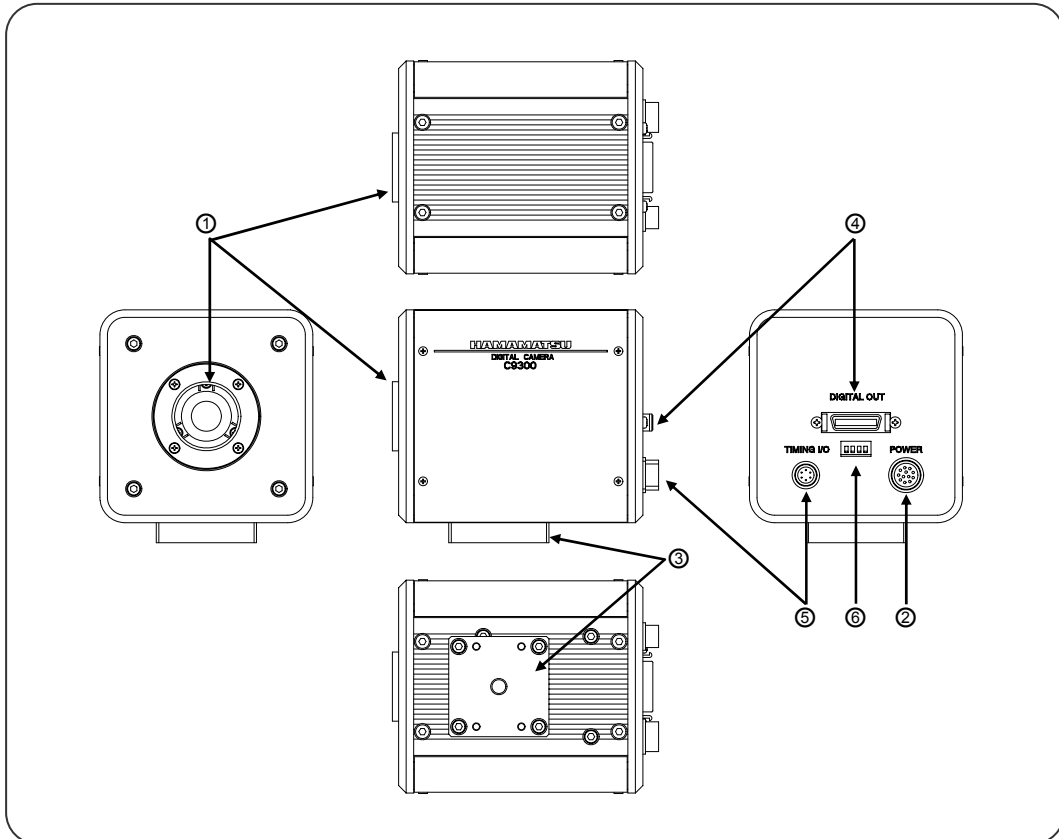

Fig. 6-1

① Lens mount

C-mount lens or optical system with C-mount can be attached.

Note

- C-mount has a depth of 7 mm. Screwing the lens too far into the camera may scratch the glass surface.

② Camera connector [POWER]

The camera is supplied a power supply from this connector. Following is the specifications of the power supply.

	Camera
Power supply voltage	DC 12 V ± DC 0.6 V
Electric current capacity	+ 1 A
Ripple noise	Peak to peak 150 mV

CAUTION

- Power supply must satisfy the above specifications to prevent trouble with the camera.



- Use low ripple noise power supplies since ripple noise may affect camera performance.

The camera employs Hirose model HR10A-10R-12PB connector.

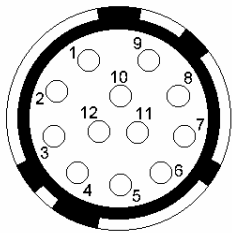
Number	Signal	Pin connection
1	GND (Camera)	 <p>HR10A-10R-12PB</p>
2	12 V (Camera)	
3	NC	
4	NC	
5	NC	
6	NC	
7	NC	
8	NC	
9	NC	
10	NC	
11	NC	
12	NC	

③ Camera mount

Jig for fixing the camera. Used when mounting the camera on a tripod or other fixture.

Note

- Be careful not to allow the fitting screw to enter more than 5 mm from the surface of the mount. Screwing this in excessively may impair normal operation.

④ CameraLink interface connector [DIGITAL OUT]

Connector used for connecting the camera to the CameraLink interface board.

⑤ Timing I/O connector [TIMING I/O]

The connector is used as the external trigger input (1st pin, 2nd pin) and the SG output (3rd pin, 4th pin).



- Do not connect anything to 5th pin and 6th pin because they are reserved for options.

⑥ Mode switching switch

This switch is for the camera maintenance.



- All positions are set to "OFF". Do not change this.

7. CONNECTING CABLES

Refer to the figure below when connecting the various cables.

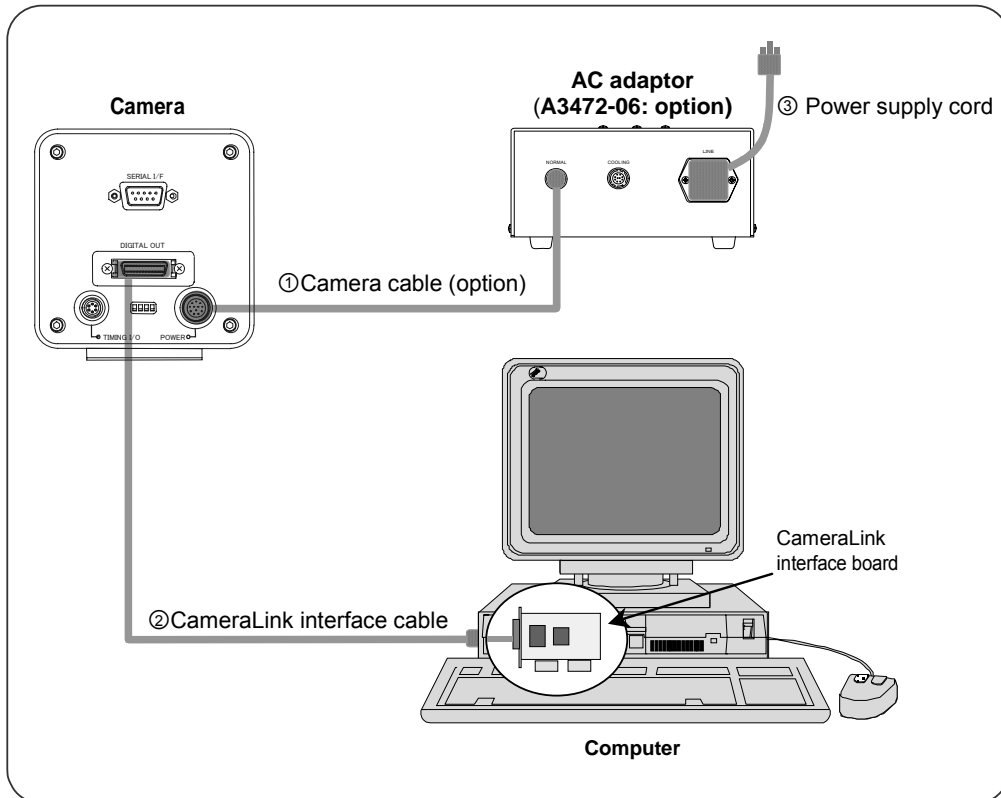

Fig. 7-1



- When cables are connected, confirming the power switch is in the OFF position.

① Camera cable (Option)

This connects the camera to the AC adaptor.

② CameraLink interface cable (Option)

This connects the CameraLink interface connector to the CameraLink interface board mounted on the host computer.

③ Power supply cord (Option: The accessories of A3472-06)

Note

- Hamamatsu recommends optional interface for the camera.
 - AC adaptor: A3472-06
 - Camera cable: A3194-01
 - CameraLink interface cable: A9262-05
 Depending on type of interface cables, the camera may not keep CE marking compliance in terms of EMC directive.

8. OPERATION

8-1 PREPARATION FOR IMAGING

- (1) Connect the equipment as shown in Fig.7-1 before starting operating of the camera.
- (2) Switch the camera's power switch to ON.
After turning the power switch on, wait approximately 10 minutes for the temperature to stabilize; this completes preparation for imaging.

8-2 IMAGING

The camera works with following setting after power is switched ON.

CCD output mode	Single output
Scan mode	Normal readout
Exposure time setting	Normal setting
Contrast enhancement gain	0
Digital data output bit count	12

The camera mode and parameters can be changed by command from the host computer, which transmitted via the CameraLink interface.

8-3 END OF IMAGING

- (1) End imaging or transmission of image data with the control software when imaging is finished.
- (2) Turn off the power to the camera and peripheral equipment.

9. IMAGE ACQUISITION

9-1 THEORY OF CCD

The all-pixel-readout interline transfer CCD used in this camera is arranged as shown in Figure 9-1. Incident light at the CCD is converted by photosensors to electrical charges which are transmitted through a shielded vertical transfer CCD (VCCD) and a horizontal transfer CCD (HCCD) to a final output charge-voltage conversion amp. The sensor gate is opened by the readout signal, and the charges generated by all of the photosensors are transmitted unmixed to the VCCD, completing the exposure.

In addition, an electronic shutter signal is applied to the CCD, allowing any accumulated charge in the photosensors to be discharged.

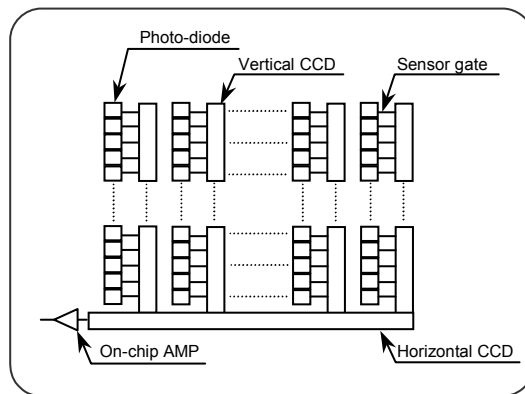

Fig. 9-1

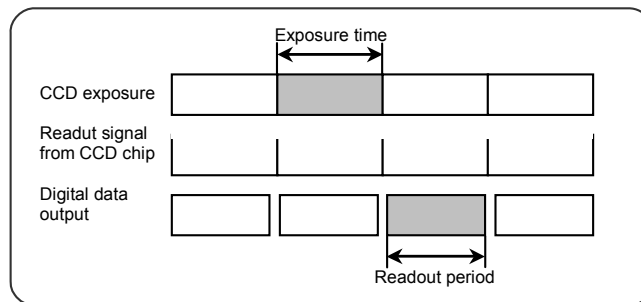

Fig. 9-2

- **Binning**

Accumulated charges for a specified number of pixels in the vertical and horizontal directions on the CCD are calculated and combined (binned), then readout from the CCD. With this camera, binning can be set to 2×2, where two pixels in the vertical and horizontal directions are combined, 4×4, where four vertical and horizontal pixels are combined, or 8×8, where eight vertical and horizontal pixels are combined.

- **Exposure Time**

When set to the normal CCD scanning mode, this is as shown in Figure 9-2. Exposure time is the elapsed time between one readout signal and the next; this interval is at least as long as the time necessary for all of the charges from the CCD to be readout.

- **Dual readout**

The CCD has dual readout amplifiers for the half left side area of the CCD and right side as shown in Figure 9-1. When using single readout mode, only left side amplifier is used. And when using dual readout mode, these two amplifiers are used at the same time for readout, so you can obtain the image data with quite high frame rate.

9-2 OVERVIEW OF CAMERA MODES

This camera features many different operational modes. Furthermore, all modes involve the CameraLink interface's built-in microprocessor, providing control and setting for all modes. Of the numerous different modes, the modes used for obtaining images are broadly classified into the two categories below.

(1) Free running mode

Exposure and readout is performed repeatedly, controlled by the internal microprocessor. Some operations for which the commands can be used are shown below.

CCD output mode	Single/Dual
Scan mode	Normal/Binning/Sub-array/Line scan
Exposure time settings	Normal /Electronic Shutter/Absolute Time
Digital data output bit count	12 bit/10 bit/8 bit

(2) External control mode

An external control (trigger) pulse input the internal microprocessor and the repeating exposure and readout. Exposure start timing and length of exposure can be controlled with the external trigger pulse. In addition, commands can be used the following.

CCD output mode	Single/Dual
Scan mode	Normal/Binning/Sub-array/Line scan
Exposure time settings	Internal (Electronic Shutter or Absolute Time)/External
Digital data output bit count	12 bit/10 bit/8 bit
External control pulse polarity	Negative/Positive

9-3 DETAIL OF CAMERA MODES

9-3-1 DIGITAL OUTPUT BIT COUNT

Select the output bit count for the digital data output by the camera.

Output	Command
12 bit digital data, output at DB0 to DB11.	ADS 12
The 10 most significant bits of the 12 bit digital data are output to DB0 to DB9.	ADS 10
The 8 most significant bits of the 12 bit digital data are output to DB0 to DB7.	ADS 8

9-3-2 CCD OUTPUT MODE

Select the output mode of CCD.

Output	Command
Single output	TNS 1
Dual output	TNS 2

Note

- Dual readout mode uses two-separated readout Amp whose performance is not perfectly same. Due to the readout Amp characteristics variation, you may see little intensity gap between right side and left side in one image even though the fine adjustment is done at factory before shipping. Single readout mode is recommended to achieve the best possible image quality.

9-3-3 DETAIL ON CCD SCANNING (SCAN MODE)

Select either normal readout or binning readout.

(1) Normal readout [SMD N]

Electrical charges from the CCD are readout in the normal, standard scanning. The time required for CCD readout of all of the CCD's pixels is approximately 12.2 ms at single output mode and 6.7 ms at dual output mode.

(2) 2x2 binning readout [SMD S, SPX 2]

Electrical charges from the CCD are readout in 2x2 binning. The time required for CCD readout of all of the CCD's pixels is approximately 6.5 ms at single output mode and 3.7 ms at dual output mode.

(3) 4x4 binning readout [SMD S, SPX 4]

Electrical charges from the CCD are readout in 4x4 binning. The time required for CCD readout of all of the CCD's pixels is approximately 3.6 ms at single output mode and 2.2 ms at dual output mode.

(4) 8x8 binning readout [SMD S, SPX 8]

Electrical charges from the CCD are readout in 4x4 binning. The time required for CCD readout of all of the CCD's pixels is approximately 2.2 ms at single output mode and 1.5 ms at dual output mode.

(5) Sub-array readout [SMD A]

In this mode, only a required area is readout at the normal speed while the remaining areas are rapidly cleared. This operation allows the frame rate to be increased.

(6) Line scan readout [SMD L]

In this mode, only a required area is readout at the normal speed while the remaining lines are rapidly cleared. This operation allows the frame rate to be increased.

9-3-4 EXPOSURE TIME SETTING

The exposure time and the methods used for making the exposure time settings are different for the free running mode and the external control mode.

The following explains more about each mode.

9-3-4-1 Free running mode [AMD N]

(1) Exposure time setting: Normal [NMD N]

Exposure and readout are performed repeatedly according to the sequence set internally. Exposure timing and exposure time is as following.

[Exposure timing]

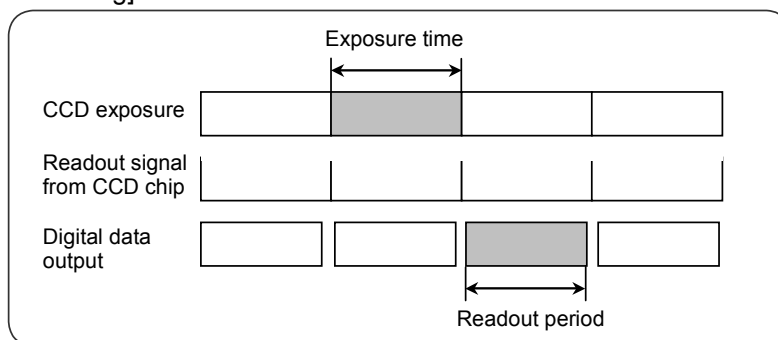

[Exposure time at each readout mode]

Single output	Normal readout	Approx. 12.2 ms (82.0 Hz)
	2×2 binning readout	Approx. 6.5 ms (155.5 Hz)
	4×4 binning readout	Approx. 3.6 ms (280.7 Hz)
	8×8 binning readout	Approx. 2.2 ms (465.0 Hz)
	Sub-array readout (SVW: readout line width)	$(SVW+2) \times 24.7 \mu s + (491-SVW) \times 1 \mu s$
	2×2 sub-array readout	$(SVW/2+2) \times 26.0 \mu s + (491-SVW/2) \times 2 \mu s$
	4×4 sub-array readout	$(SVW/4+2) \times 28.7 \mu s + (491-SVW/4) \times 4 \mu s$
	8×8 sub-array readout	$(SVW/8+2) \times 34.1 \mu s + (491-SVW/4) \times 8 \mu s$
	Line scan readout (n : readout line number)	$(n+1) \times 30.7 \mu s + (492-n) \times 1 \mu s$
Dual output	Normal readout	Approx. 6.7 ms (150.6 Hz)
	2×2 binning readout	Approx. 3.7 ms (274.2 Hz)
	4×4 binning readout	Approx. 2.2 ms (461.7 Hz)
	8×8 binning readout	Approx. 1.5 ms (694.2 Hz)
	Sub-array readout (SVW: readout line width)	$(SVW+2) \times 13.5 \mu s + (491-SVW) \times 1 \mu s$
	2×2 sub-array readout	$(SVW/2+2) \times 14.8 \mu s + (491-SVW/2) \times 2 \mu s$
	4×4 sub-array readout	$(SVW/4+2) \times 17.5 \mu s + (491-SVW/4) \times 4 \mu s$
	8×8 sub-array readout	$(SVW/8+2) \times 22.9 \mu s + (491-SVW/4) \times 8 \mu s$
	Line scan readout (n : readout line number)	$(n+1) \times 19.5 \mu s + (492-n) \times 1 \mu s$

(2) Exposure time setting: Electronic Shutter [NMD S·SHT n]

Exposure and readout repeat along with the operation of the electronic shutter according to the sequence set internally. The exposure time is set with the SHT n command. This setting is made in units of one horizontal scan cycle for each scan mode. Exposure timing and exposure time is as following.

[Exposure timing]

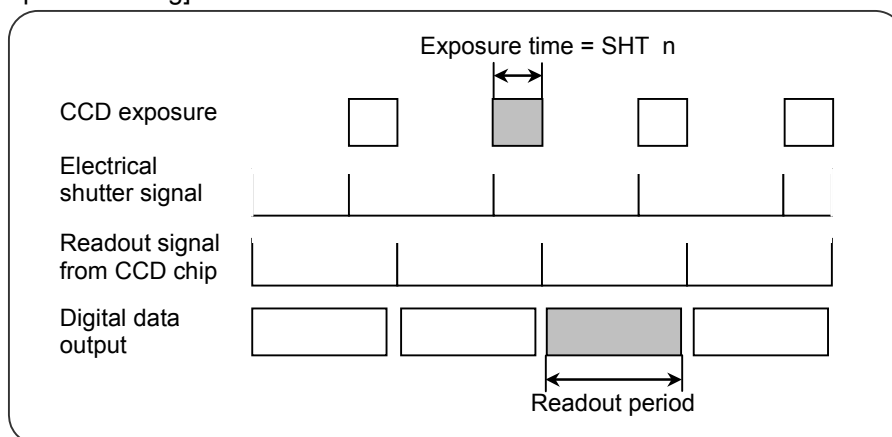

[Exposure time at each readout mode]

Single output	Normal readout	$33.1 \mu\text{s} + (n-1) \times 24.7 \mu\text{s}$ (n = 1 to 40432)
	2×2 binning readout	$34.4 \mu\text{s} + (n-1) \times 26.0 \mu\text{s}$ (n = 1 to 38413)
	4×4 binning readout	$37.1 \mu\text{s} + (n-1) \times 28.7 \mu\text{s}$ (n = 1 to 34803)
	8×8 binning readout	$42.5 \mu\text{s} + (n-1) \times 34.1 \mu\text{s}$ (n = 1 to 29297)
	1 line scan readout	$552 \mu\text{s} + (n-493) \times 30.7 \mu\text{s}$ (n = 493 to 33013)
	2 line scan readout	$582 \mu\text{s} + (n-493) \times 30.7 \mu\text{s}$ (n = 493 to 33013)
	3 line scan readout	$612 \mu\text{s} + (n-493) \times 30.7 \mu\text{s}$ (n = 493 to 33012)
	4 line scan readout	$642 \mu\text{s} + (n-493) \times 30.7 \mu\text{s}$ (n = 493 to 33011)
	5 line scan readout	$671 \mu\text{s} + (n-493) \times 30.7 \mu\text{s}$ (n = 493 to 33010)
	6 line scan readout	$701 \mu\text{s} + (n-493) \times 30.7 \mu\text{s}$ (n = 493 to 33009)
	7 line scan readout	$731 \mu\text{s} + (n-493) \times 30.7 \mu\text{s}$ (n = 493 to 33008)
	8 line scan readout	$761 \mu\text{s} + (n-493) \times 30.7 \mu\text{s}$ (n = 493 to 33007)
	9 line scan readout	$790 \mu\text{s} + (n-493) \times 30.7 \mu\text{s}$ (n = 493 to 33006)
	10 line scan readout	$820 \mu\text{s} + (n-493) \times 30.7 \mu\text{s}$ (n = 493 to 33005)
	11 line scan readout	$850 \mu\text{s} + (n-493) \times 30.7 \mu\text{s}$ (n = 493 to 33004)
	12 line scan readout	$880 \mu\text{s} + (n-493) \times 30.7 \mu\text{s}$ (n = 493 to 33003)
13 line scan readout	$909 \mu\text{s} + (n-493) \times 30.7 \mu\text{s}$ (n = 493 to 33002)	
14 line scan readout	$939 \mu\text{s} + (n-493) \times 30.7 \mu\text{s}$ (n = 493 to 33001)	
15 line scan readout	$969 \mu\text{s} + (n-493) \times 30.7 \mu\text{s}$ (n = 493 to 33000)	
16 line scan readout	$998 \mu\text{s} + (n-493) \times 30.7 \mu\text{s}$ (n = 493 to 32999)	

Dual output	Normal readout	$21.9 \mu\text{s} + (n-1) \times 13.5 \mu\text{s}$ (n = 1 to 74258)
	2×2 binning readout	$23.2 \mu\text{s} + (n-1) \times 14.8 \mu\text{s}$ (n = 1 to 67721)
	4×4 binning readout	$25.9 \mu\text{s} + (n-1) \times 17.5 \mu\text{s}$ (n = 1 to 27252)
	8×8 binning readout	$31.3 \mu\text{s} + (n-1) \times 22.9 \mu\text{s}$ (n = 1 to 43732)
	1 line scan readout	$530 \mu\text{s} + (n-493) \times 19.5 \mu\text{s}$ (n = 493 to 51836)
	2 line scan readout	$548 \mu\text{s} + (n-493) \times 19.5 \mu\text{s}$ (n = 493 to 51835)
	3 line scan readout	$567 \mu\text{s} + (n-493) \times 19.5 \mu\text{s}$ (n = 493 to 51834)
	4 line scan readout	$585 \mu\text{s} + (n-493) \times 19.5 \mu\text{s}$ (n = 493 to 51833)
	5 line scan readout	$604 \mu\text{s} + (n-493) \times 19.5 \mu\text{s}$ (n = 493 to 51832)
	6 line scan readout	$622 \mu\text{s} + (n-493) \times 19.5 \mu\text{s}$ (n = 493 to 51831)
	7 line scan readout	$641 \mu\text{s} + (n-493) \times 19.5 \mu\text{s}$ (n = 493 to 51830)
	8 line scan readout	$659 \mu\text{s} + (n-493) \times 19.5 \mu\text{s}$ (n = 493 to 51829)
	9 line scan readout	$678 \mu\text{s} + (n-493) \times 19.5 \mu\text{s}$ (n = 493 to 51829)
	10 line scan readout	$696 \mu\text{s} + (n-493) \times 19.5 \mu\text{s}$ (n = 493 to 51828)
	11 line scan readout	$715 \mu\text{s} + (n-493) \times 19.5 \mu\text{s}$ (n = 493 to 51827)
	12 line scan readout	$733 \mu\text{s} + (n-493) \times 19.5 \mu\text{s}$ (n = 493 to 51826)
13 line scan readout	$752 \mu\text{s} + (n-493) \times 19.5 \mu\text{s}$ (n = 493 to 51825)	
14 line scan readout	$770 \mu\text{s} + (n-493) \times 19.5 \mu\text{s}$ (n = 493 to 51824)	
15 line scan readout	$788 \mu\text{s} + (n-493) \times 19.5 \mu\text{s}$ (n = 493 to 51823)	
16 line scan readout	$807 \mu\text{s} + (n-493) \times 19.5 \mu\text{s}$ (n = 493 to 51822)	

(3) Exposure time setting: Absolute Time [NMD T, AET ss.xxx]

Exposure and readout repeat along with the operation of the electronic shutter according to the sequence set internally. The exposure time is set with the AET ss.xxx command (where s = seconds, x = milliseconds). The actual length of exposure time is the specified time taken as a value expressed in horizontal scan units. Exposure time longer than 1 s is not possible.

9-3-4-2 External control mode [AMD E]

The external trigger pulse is input via the timing I/O connector on the rear panel and the polarity is selected from “N” (negative: Low-level active) or “P” (positive: High-level active). The external trigger pulse should be TTL level and the minimum active period is 1 μ s and the repeat cycle must match the selected mode.

Note

- Images are not output correctly if the pulse input is shorter than 1 μ s.

The following text describes the external control mode with the external trigger pulse polarity set to “N” (negative). If “P” (positive) is selected, the rise and fall of each pulse is reversed (inverted), with the LO interval becoming the HI interval. Descriptions enclosed in brackets ({ }) indicate cases where “P” (positive) is selected.

(1) Exposure time setting: Internal / Electronic Shutter [EMD E, EST n]

Exposure begins within 2 μ s from the fall {rise} of the external trigger pulse, the exposure is made using the time set with the EST n command, and readout follows. After readout, the system waits for the external trigger pulse to fall {rise} again. The exposure time is set with the EST n command. This setting is made in units of one horizontal scan cycle. The repeat cycle is controlled by the external control pulse's repeat cycle, but the minimum cycle is calculated as shown below. Set the external control pulse's repeat cycle so that it is longer than the minimum cycle.

$$\text{Minimum repetition time} = \text{readout time} + \text{set exposure time}$$

[Exposure timing]

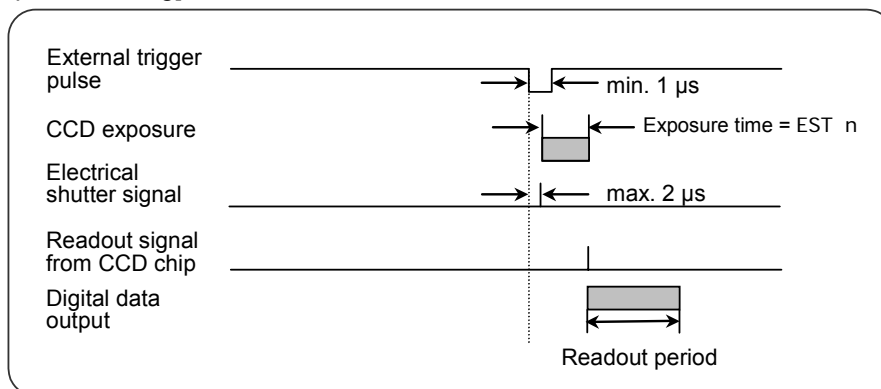

[Exposure time at each readout mode]

Single output	Normal readout (1×1 sub-array readout)	$33.1 \mu\text{s} + (n-1) \times 24.7 \mu\text{s}$ (n = 1 to 40432)
	2×2 binning readout (2×2 sub-array readout)	$34.4 \mu\text{s} + (n-1) \times 26.0 \mu\text{s}$ (n = 1 to 38413)
	4×4 binning readout (4×4 sub-array readout)	$37.1 \mu\text{s} + (n-1) \times 28.7 \mu\text{s}$ (n = 1 to 34803)
	8×8 binning readout (8×8 sub-array readout)	$42.5 \mu\text{s} + (n-1) \times 34.1 \mu\text{s}$ (n = 1 to 29326)
	Line scan readout	$39.1 \mu\text{s} + (n-1) \times 30.7 \mu\text{s}$ (n = 1 to 32538)
Dual output	Normal readout (1×1 sub-array readout)	$21.9 \mu\text{s} + (n-1) \times 13.5 \mu\text{s}$ (n = 1 to 74258)
	2×2 binning readout (2×2 sub-array readout)	$23.2 \mu\text{s} + (n-1) \times 14.8 \mu\text{s}$ (n = 1 to 67721)
	4×4 binning readout (4×4 sub-array readout)	$25.9 \mu\text{s} + (n-1) \times 17.5 \mu\text{s}$ (n = 1 to 27252)
	8×8 binning readout (8×8 sub-array readout)	$31.3 \mu\text{s} + (n-1) \times 22.9 \mu\text{s}$ (n = 1 to 43668)
	Line scan readout	$27.9 \mu\text{s} + (n-1) \times 19.5 \mu\text{s}$ (n = 1 to 51370)

[Readout time at each readout mode]

Single output	Normal readout	Approx. 12.2 ms
	2×2 binning readout	Approx. 6.5 ms
	4×4 binning readout	Approx. 3.6 ms
	8×8 binning readout	Approx. 2.2 ms
	1×1 sub-array readout (SVW: readout line width)	$(\text{SVW}+2) \times 24.7 \mu\text{s} + (491-\text{SVW}) \times 1 \mu\text{s}$
	2×2 sub-array readout	$(\text{SVW}/2+2) \times 26.0 \mu\text{s} + (491-\text{SVW}/2) \times 2 \mu\text{s}$
	4×4 sub-array readout	$(\text{SVW}/4+2) \times 28.7 \mu\text{s} + (491-\text{SVW}/4) \times 4 \mu\text{s}$
	8×8 sub-array readout	$(\text{SVW}/8+2) \times 34.1 \mu\text{s} + (491-\text{SVW}/4) \times 8 \mu\text{s}$
	Line scan readout (n : readout line number)	$(n+1) \times 30.7 \mu\text{s} + (492-n) \times 1 \mu\text{s}$
Dual output	Normal readout	Approx. 6.7 ms
	2×2 binning readout	Approx. 3.7 ms
	4×4 binning readout	Approx. 2.2 ms
	8×8 binning readout	Approx. 1.5 ms
	1×1 sub-array readout (SVW: readout line width)	$(\text{SVW}+2) \times 13.5 \mu\text{s} + (491-\text{SVW}) \times 1 \mu\text{s}$
	2×2 sub-array readout	$(\text{SVW}/2+2) \times 14.8 \mu\text{s} + (491-\text{SVW}/2) \times 2 \mu\text{s}$
	4×4 sub-array readout	$(\text{SVW}/4+2) \times 17.5 \mu\text{s} + (491-\text{SVW}/4) \times 4 \mu\text{s}$
	8×8 sub-array readout	$(\text{SVW}/8+2) \times 22.9 \mu\text{s} + (491-\text{SVW}/4) \times 8 \mu\text{s}$
	Line scan readout (n : readout line number)	$(n+1) \times 19.5 \mu\text{s} + (492-n) \times 1 \mu\text{s}$

(2) Exposure time setting: Internal / Absolute Time [EMD T, AET ss.xxx]

Exposure begins within 2 μs from the fall {rise} of the external trigger pulse, the exposure is made using the time set with the AET ss. xxx command, and readout follows. After readout, the system waits for the external trigger pulse to fall {rise} again. The exposure time is set with the AET ss. xxx command (where s = seconds, x = milliseconds). The actual length of exposure time is the specified time taken as a value expressed in horizontal scan units. Exposure time longer than 1 s is not possible. The repeat cycle is controlled by the external control pulse's repeat cycle, but the minimum cycle is calculated as shown below. Set the external control pulse's repeat cycle so that it is longer than the minimum cycle.

$$\text{Minimum repetition time} = \text{readout time} + \text{set exposure time}$$

[Readout time at each readout mode]

Single output	Normal readout	Approx. 12.2 ms
	2×2 binning readout	Approx. 6.5 ms
	4×4 binning readout	Approx. 3.6 ms
	8×8 binning readout	Approx. 2.2 ms
	1×1 sub-array readout (SVW: readout line width)	$(\text{SVW}+2) \times 24.7 \mu\text{s} + (491-\text{SVW}) \times 1 \mu\text{s}$
	2×2 sub-array readout	$(\text{SVW}/2+2) \times 26.0 \mu\text{s} + (491-\text{SVW}/2) \times 2 \mu\text{s}$
	4×4 sub-array readout	$(\text{SVW}/4+2) \times 28.7 \mu\text{s} + (491-\text{SVW}/4) \times 4 \mu\text{s}$
	8×8 sub-array readout	$(\text{SVW}/8+2) \times 34.1 \mu\text{s} + (491-\text{SVW}/4) \times 8 \mu\text{s}$
	Line scan readout (n : readout line number)	$(n+1) \times 30.7 \mu\text{s} + (492-n) \times 1 \mu\text{s}$
Dual output	Normal readout	Approx. 6.7 ms
	2×2 binning readout	Approx. 3.7 ms
	4×4 binning readout	Approx. 約 2.2 ms
	8×8 binning readout	Approx. 1.5 ms
	1×1 sub-array readout (SVW: readout line width)	$(\text{SVW}+2) \times 13.5 \mu\text{s} + (491-\text{SVW}) \times 1 \mu\text{s}$
	2×2 sub-array readout	$(\text{SVW}/2+2) \times 14.8 \mu\text{s} + (491-\text{SVW}/2) \times 2 \mu\text{s}$
	4×4 sub-array readout	$(\text{SVW}/4+2) \times 17.5 \mu\text{s} + (491-\text{SVW}/4) \times 4 \mu\text{s}$
	8×8 sub-array readout	$(\text{SVW}/8+2) \times 22.9 \mu\text{s} + (491-\text{SVW}/4) \times 8 \mu\text{s}$
	Line scan readout (n : readout line number)	$(n+1) \times 19.5 \mu\text{s} + (492-n) \times 1 \mu\text{s}$

(3) Exposure time setting: External [EMD L]

Exposure begins within 2 μs from the fall {rise} of the external trigger pulse. After this, when external trigger pulse rises {falls} again, the exposure is stopped within 27 μs , and the data is read out. After readout, the system waits for the external trigger pulse to fall {rise} again. The exposure time is controlled according to the external control pulse's LO interval {HI interval}. The repeat cycle is controlled by the external control pulse's repeat cycle, but the minimum cycle is calculated as shown below.

Minimum repetition time = readout time + external control pulse's LO interval {HI interval} (exposure time)

Note

- The external control pulse's LO interval {HI interval} must be at least 100 μs .

Set the external control pulse's repeat cycle so that it is longer than the minimum cycle. Maximum exposure time is 1 s. When the external control pulse's LO interval {HI interval} exceeds 1 s, the exposure is stopped and the data is read out (exposure cannot exceed 1 s).

[Exposure timing]

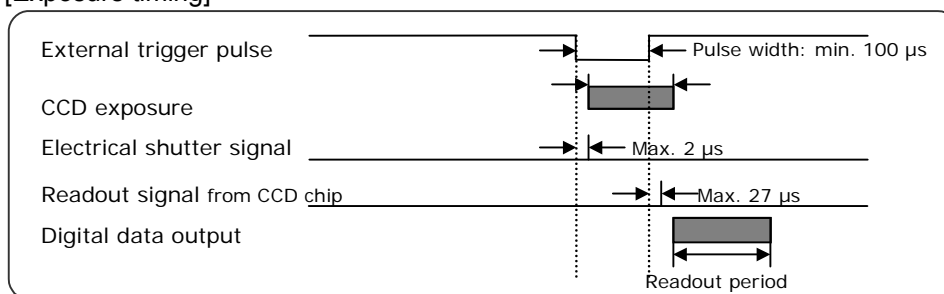

[Readout time at each readout mode]

Single output	Normal readout	Approx. 12.2 ms
	2×2 binning readout	Approx. 6.5 ms
	4×4 binning readout	Approx. 3.6 ms
	8×8 binning readout	Approx. 2.2 ms
	1×1 sub-array readout (SVW: readout line width)	$(\text{SVW}+2) \times 24.7 \mu\text{s} + (491-\text{SVW}) \times 1 \mu\text{s}$
	2×2 sub-array readout	$(\text{SVW}/2+2) \times 26.0 \mu\text{s} + (491-\text{SVW}/2) \times 2 \mu\text{s}$
	4×4 sub-array readout	$(\text{SVW}/4+2) \times 28.7 \mu\text{s} + (491-\text{SVW}/4) \times 4 \mu\text{s}$
	8×8 sub-array readout	$(\text{SVW}/8+2) \times 34.1 \mu\text{s} + (491-\text{SVW}/4) \times 8 \mu\text{s}$
Line scan readout (n : readout line number)	$(n+1) \times 30.7 \mu\text{s} + (492-n) \times 1 \mu\text{s}$	
Dual output	Normal readout	Approx. 6.7 ms
	2×2 binning readout	Approx. 3.7 ms
	4×4 binning readout	Approx. 2.2 ms
	8×8 binning readout	Approx. 1.5 ms
	1×1 sub-array readout (SVW: readout line width)	$(\text{SVW}+2) \times 13.5 \mu\text{s} + (491-\text{SVW}) \times 1 \mu\text{s}$
	2×2 sub-array readout	$(\text{SVW}/2+2) \times 14.8 \mu\text{s} + (491-\text{SVW}/2) \times 2 \mu\text{s}$
	4×4 sub-array readout	$(\text{SVW}/4+2) \times 17.5 \mu\text{s} + (491-\text{SVW}/4) \times 4 \mu\text{s}$
	8×8 sub-array readout	$(\text{SVW}/8+2) \times 22.9 \mu\text{s} + (491-\text{SVW}/4) \times 8 \mu\text{s}$
Line scan readout (n : readout line number)	$(n+1) \times 19.5 \mu\text{s} + (492-n) \times 1 \mu\text{s}$	

(4) Exposure time setting: External (Synchronous readout trigger mode) [EMD S]

Exposure begins within 10 μs from the fall {rise} of the external trigger pulse. After readout, the system waits for the external trigger pulse to fall {rise} again. The exposure time is controlled according to the external control pulse's LO interval {HI interval}. The repeat cycle is controlled by the external control pulse's repeat cycle, but the minimum cycle is calculated as shown below.

Minimum repetition time = Readout time

Set the external control pulse's repeat cycle so that it is longer than the minimum cycle.

Note

- The external control pulse's LO interval {HI interval} must be at least 1 μs .

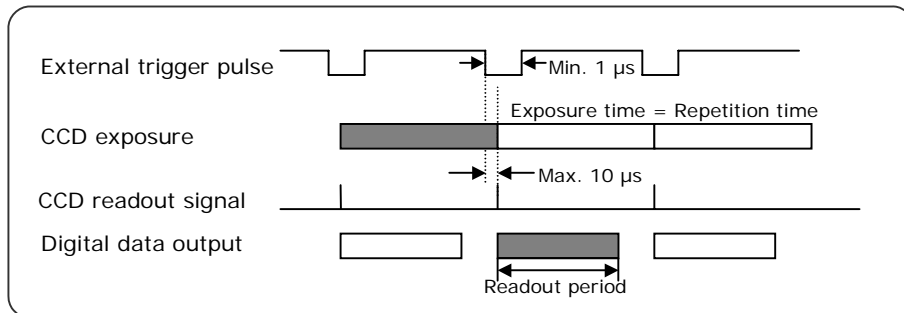

[Readout time at each readout mode]

Single output	Normal readout	Approx. 12.2 ms
	2×2 binning readout	Approx. 6.5 ms
	4×4 binning readout	Approx. 3.6 ms
	8×8 binning readout	Approx. 2.2 ms
	1×1 sub-array readout (SVW: readout line width)	$(\text{SVW}+2) \times 24.7 \mu\text{s} + (491-\text{SVW}) \times 1 \mu\text{s}$
	2×2 sub-array readout	$(\text{SVW}/2+2) \times 26.0 \mu\text{s} + (491-\text{SVW}/2) \times 2 \mu\text{s}$
	4×4 sub-array readout	$(\text{SVW}/4+2) \times 28.7 \mu\text{s} + (491-\text{SVW}/4) \times 4 \mu\text{s}$
	8×8 sub-array readout	$(\text{SVW}/8+2) \times 34.1 \mu\text{s} + (491-\text{SVW}/4) \times 8 \mu\text{s}$
	Line scan readout (n : readout line number)	$(n+1) \times 30.7 \mu\text{s} + (492-n) \times 1 \mu\text{s}$
Dual output	Normal readout	Approx. 6.7 ms
	2×2 binning readout	Approx. 3.7 ms
	4×4 binning readout	Approx. 2.2 ms
	8×8 binning readout	Approx. 1.5 ms
	1×1 sub-array readout (SVW: readout line width)	$(\text{SVW}+2) \times 13.5 \mu\text{s} + (491-\text{SVW}) \times 1 \mu\text{s}$
	2×2 sub-array readout	$(\text{SVW}/2+2) \times 14.8 \mu\text{s} + (491-\text{SVW}/2) \times 2 \mu\text{s}$
	4×4 sub-array readout	$(\text{SVW}/4+2) \times 17.5 \mu\text{s} + (491-\text{SVW}/4) \times 4 \mu\text{s}$
	8×8 sub-array readout	$(\text{SVW}/8+2) \times 22.9 \mu\text{s} + (491-\text{SVW}/4) \times 8 \mu\text{s}$
	Line scan readout (n : readout line number)	$(n+1) \times 19.5 \mu\text{s} + (492-n) \times 1 \mu\text{s}$

9-3-5 FAST REPETITION MODE

The camera has a Fast repetition mode (Dual Image Acquisition/PIV mode) as one of it is external trigger mode as an option. In this mode, the camera can be set to acquire a pair of images with interval as short as 100 ns at full resolution (640x480). This mode is especially useful for PIV (Particle Image Velocimetry) and other flow imaging application. Moreover, the CCD has dual output feature which enables higher frame rate.

9-3-5-1 Additional commands for Fast repetition feature

To set the fast repetition mode, "EMD" command is used. (Default:EMD E)

The command for fast repetition mode is; EMD F (External trigger MoDe Fast repetition mode)

Example: Set as follows.

TNS 2 : Dual output mode.
ESC M : External trigger, TIMING I/O connector
AMD E : Acquire mode is external
ATP N : Active trigger polarity, negative
EST 1 : External shutter is 1
EMD F : External mode is Fast repetition mode

9-3-5-2 Timing chart

The timing signal for shifting CCD electric charge to vertical shift register is output from the camera through pin No. 3 of TIMING I/O (6 pin) connector on the rear panel of the camera. The output signal is a TTL level. Refer to the timing chart.

[Timing chart]

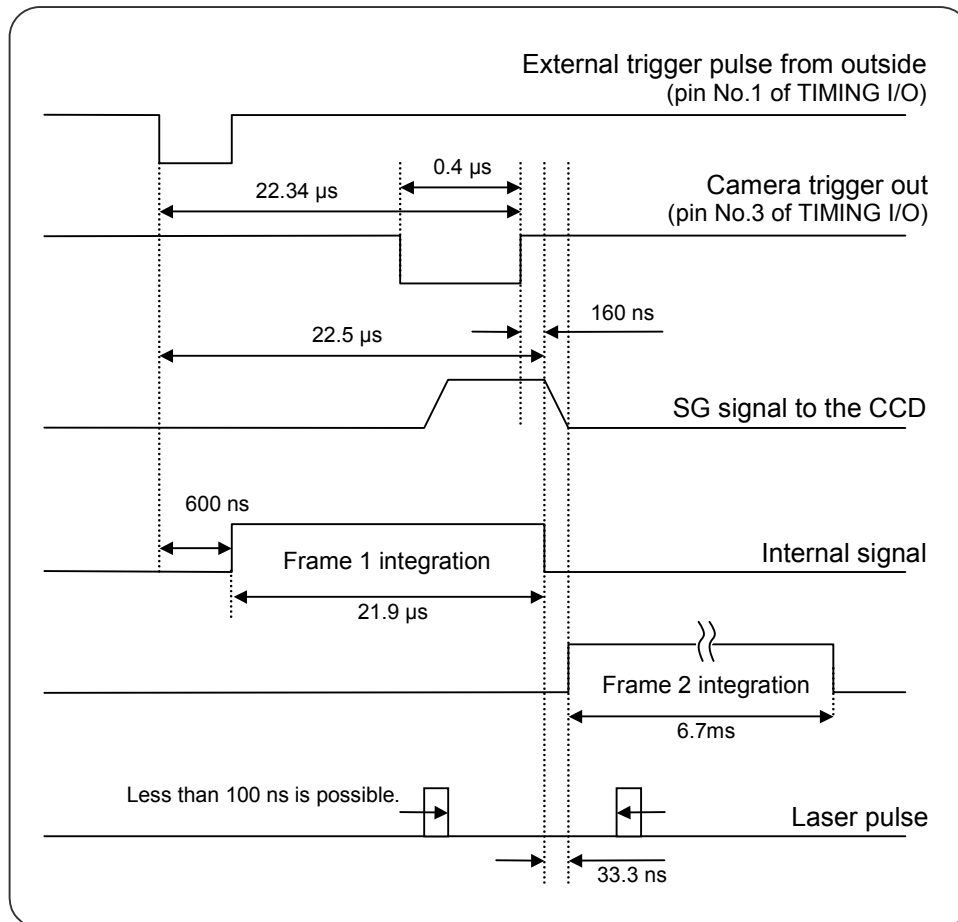

Exposure time is first set by EST command while in external edged trigger mode. Minimum exposure time (21.9 μs) is obtained by the setting, EST 1 and TNS 2. This timing chart shows the fastest speed mode.

On the falling edge of an external trigger plus the camera starts the first frame exposure with a 600 ns delay time. The first frame exposure time is set by the command of EST n. If n=1 and TNS 2, the exposure time is 21.9 μs. The total time until finishing one frame exposure is therefore 22.5 μs. The camera outputs the end of exposure signal as a camera trigger output. From this signal it is known when first frame exposure is finished. After the falling edge of camera trigger out signal the next frame integration starts immediately.

From this timing, you can make the timing between two laser pulse as short as possible. To increase the 1 frame exposure time, EST n may be increased in increments of 13.5 μs at 1×1 mode.

The exposure time for first frame is calculated by following expression.

[TNS 2 (Dual output mode)]

Exposure time for 1×1 binning readout = $21.9 \mu\text{s} + (n-1) \times 13.5 \mu\text{s}$	(n=1 to 74258)
Exposure time for 2×2 binning readout = $23.2 \mu\text{s} + (n-1) \times 14.8 \mu\text{s}$	(n=1 to 67721)
Exposure time for 4×4 binning readout = $25.9 \mu\text{s} + (n-1) \times 17.5 \mu\text{s}$	(n=1 to 57252)
Exposure time for 8×8 binning readout = $31.3 \mu\text{s} + (n-1) \times 22.9 \mu\text{s}$	(n=1 to 43732)

[TNS 1 (Single output mode)]

Exposure time for 1×1 binning readout = $33.1 \mu\text{s} + (n-1) \times 24.7 \mu\text{s}$	(n=1 to 40432)
Exposure time for 2×2 binning readout = $34.4 \mu\text{s} + (n-1) \times 26.0 \mu\text{s}$	(n=1 to 38413)
Exposure time for 4×4 binning readout = $37.1 \mu\text{s} + (n-1) \times 28.7 \mu\text{s}$	(n=1 to 34803)
Exposure time for 8×8 binning readout = $42.5 \mu\text{s} + (n-1) \times 34.1 \mu\text{s}$	(n=1 to 29297)

Second frame is always as follows.

[TNS 2 (Dual output mode)]

Exposure time for 1×1 binning readout = 6.7 ms
Exposure time for 2×2 binning readout = 3.7 ms
Exposure time for 4×4 binning readout = 2.2 ms
Exposure time for 8×8 binning readout = 1.5 ms

[TNS 1 (Single output mode)]

Exposure time for 1×1 binning readout = 12.2 ms
Exposure time for 2×2 binning readout = 6.5 ms
Exposure time for 4×4 binning readout = 3.6 ms
Exposure time for 8×8 binning readout = 2.2 ms

10. COMMAND SPECIFICATIONS

10-1 TRANSMISSION INTERFACE

The camera is controlled from the host computer through the serial interface. Specifications for the serial interface are shown below.

Baud rate	9600
Data length	8
Parity bit	None
Stop bit	1

10-2 COMMAND FORMAT

(1) Basic system

External control commands for the camera are output by the computer in the following format.

Command_Parameter	CR	CR: Carriage return
--------------------------	-----------	---------------------

"CR" appended to a command being output indicates the end of the data. Spaces (_) are used to separate commands from parameters in commands requiring the inclusion of parameters.

10-3 CAMERA RESPONSE TO COMMANDS

The camera responds to commands transmitted from the host computer. The camera can be set so that a response is either sent or withheld when the RESponse command is received. However, responses to status commands from the camera cannot be refused.

RES	(RESponse)		
	Function	Setting allows or prevents responses when commands are sent from the host computer.	
	Parameter	Y	Response is transmitted for each separate command. (Default)
N		Response is not transmitted for each separate command.	

The following describes cases in which the camera responds to the RES command. Responses indicate the completion of actions the camera performs when the corresponding commands are received; responses differ according to the type of command received by the camera.

(1) Response to operating commands and setting commands

When execution of a command proceeds normally, a reply with the executed command (with parameter) is sent back to the host computer.

XXX_PP	CR
--------	----

XXX : Executed command
PP : Parameter

If the command sent by the computer contains an error (undefined command, parameter error), the character string below is sent as an error message.

E3	CR
----	----

If the command sent by the host computer is not suitable for the currently operating mode, the character string below is sent as an error message.

E4	CR
----	----

If there is an error in the command parameters sent by the host computer (undefined parameters), the character string below is sent as an error message.

E5	CR
----	----

If the command parameters sent by the host computer are not suitable for the currently operating mode, the character string below is sent as an error message.

E6	CR
----	----

(2) Response to status commands

This is always output; regardless of the RES command setting.

When the camera interprets a command as being proper, the response to the command's execution is to send back to the host computer the required status. Accordingly, the status command is executed normally, and the response is the transmission of the status to the host computer.

XXX_PP	CR
--------	----

XXX: Command name (3 characters, omitting "?")
PP: Status response to the command

Just as described above, when the command sent by the computer contains an error (undefined command, parameter error), the character string below is sent as an error message.

E3	CR
----	----

(3) Reply when error occurs on reception

There are two things to be considered when an error occurs during reception. One is framing, parity, or overrun errors; the other is the possible overloading of the input buffer. The fact that one of these errors has occurred is transmitted in the character string below.

En	CR
----	----

Here, n indicates an error, with the type of error indicated by the following.

N = 1: Framing, parity, or overrun error

n = 2: Input buffer overload

Moreover, when either of the two errors above occurs, the command generating the error is cancelled from the camera's input buffer.

10-4 OVERVIEW OF COMMANDS

The external control commands are categorized into the five following groups.

- Mode setting commands
- Parameter setting commands
- Correctional commands
- Other setting commands
- Status commands

(1) Mode setting commands

This group contains commands that switch the modes used in obtaining images.

AMD	Selects the camera mode in the CCD exposure start timing.
NMD	Selects the method used to set the exposure time when the exposure timing is controlled internally.
EMD	Selects the method used to set the exposure time when the exposure start timing is External control mode.
SMD	Selects the scan mode.
ADS	Selects the digital data output bit count.
TNS	Selects the CCD output mode.

(2) Parameter setting commands

This group contains commands for setting parameters such as exposure time and digital output pixel count.

SHT	Sets the exposure time when the exposure trigger timing is controlled internally.
EST	Sets the exposure time when the exposure trigger timing is controlled externally.
AET	Sets the exposure time.
ATP	Selects the external trigger pulse polarity.
SPX	Selects the binning count when the binning command is selected with SMD command.
SVO	Sets the sub-array's vertical start address.
SVW	Sets the sub-array's vertical line width.
SLP	Sets the line scan's readout line.
ESC	Selects the input connector for external control pulse.

(3) Correctional commands

This group contains commands for setting the contrast enhancement function and other picture-correction settings.

CEG	Sets the contrast enhancement gain.
-----	-------------------------------------

(4) Other setting commands

This group contains commands for initializing the camera and for other setting.

INI	Sets the various settings that determine the camera's overall operation to the initial values.
RES	Selects whether responses are made to commands.

(5) Status commands

When the host computer outputs a status command, the camera then returns a response. All status commands are preceded by a question mark ("?"); if the status command is contained within a setting command, the question mark is added at the beginning of the command.

?AMD	Returns the setting the camera mode in the CCD exposure start timing.
?NMD	Returns the setting for the method used to set the exposure time when the exposure timing is controlled internally.
?EMD	Returns the setting the method used to set the exposure time when the exposure start timing is External control mode.
?SMD	Returns the setting the scan mode.
?ADS	Returns the setting the digital data output bit count.
?TNS	Returns the setting the CCD output mode.
?SHT	Returns the exposure time when the exposure trigger timing is controlled internally.
?EST	Returns the exposure time when the exposure trigger timing is controlled externally.
?AET	Returns the setting of exposure time.
?ATP	Returns the external trigger pulse polarity.
?SPX	Returns the setting of the binning count.
?SVO	Returns the setting value for the vertical start address.
?SVW	Returns the setting value for the vertical line width.
?SLP	Returns the setting value for the readout line.
?ESC	Returns the setting the input connector for external control pulse.
?CEG	Returns the setting value the contrast enhancement gain.
?RES	Returns the setting for the command response.
?VER	Returns the version of the camera's internal components.
?INF	Returns the information of the camera's internal components.
?CAI	Returns the information about the camera hardware.

10-5 COMMAND INITIAL SETTING

Setting commands are set as shown below with the power is turned on. These settings are initialized, regardless of the "I NI" command.

Category	Initial command
Mode setting commands	AMD N (Free running mode)
	NMD N (Normal)
	EMD E (Edge)
	SMD N (Normal readout)
	ADS 12 (12 bit)
	TNS 1 (Single output)
Parameter setting commands	SHT 493 (493)
	EST 1 (1)
	AET 0.012194 (12.194 ms)
	ATP N (Negative)
	SPX 2 (2×2)
	SVO 0 (0)
	SVW 480 (480)
	SLP 0,1,2,3,4,5,6,7,8,9,10,11,12,13,14,15,16 (0,1,2,3,4,5,6,7,8,9,10,11,12,13,14,15,16)
	ESC M (Multi Timing I/O)
Correctional commands	CEG 0 (0)
Other setting commands	RES Y (Yes)

10-6 DETAIL OF COMMANDS

(1) Mode setting commands

AMD	(Acquire MoDe)		
	Parameter	N (Normal)/E (External)	
	Function	Selects Free running mode or External control mode for the CCD exposure start timing.	
	Example	AMD N	Image acquisition is started in Free running mode.
AMD E		Image acquisition is started in External control mode.	
NMD	(Normal MoDe)		
	Parameter	N (Normal)/S (Shutter)/T (Time)	
	Function	Selects mode used to set the exposure time when the exposure timing is controlled internally.	
	Example	NMD N	Exposure time is normal readout time at each mode.
NMD S		Exposure time is set with the SHT command.	
NMD T		Exposure time is set with the AET command.	
EMD	(External MoDe)		
	Parameter	E (Edge)/L (Level)/T (Time)/S (Synchronous readout)/F (Fast repetition)	
	Function	Selects mode used to set the exposure time when the exposure timing is controlled External control mode.	
	Example	EMD E	Exposure time is set internally with the EST command.
		EMD L	Exposure time is set externally according to external trigger level.
		EMD T	Exposure time is set internally with the AET command.
EMD S		Readout time is set externally according to external trigger cycle.	
EMD F		This mode is special fast repetition mode. Please see section 9-3-5 in detail.	
SMD	(Scan MoDe)		
	Parameter	N (Normal)/S (Super pixel)/A (Sub-array)/L (Line scan)	
	Function	Selects Normal readout, Binning (super pixel) readout, Sub-array readout or Line scan readout.	
	Example	SMD N	The data is readout using Normal readout.
		SMD S	The data is readout using Binning (super pixel) readout.
SMD A		The data is readout using Sub-array readout.	
SMD L		The data is readout using Line scan readout.	

ADS	(A/D Select)																																																	
	Parameter	12 (12 bit output)/10 (10 bit output)/8 (8 bit output)																																																
	Function	Selects 12 bit output, 10 bit output or 8 bit output.																																																
	Example	ADS 12	12 bit digital data is output to DB0 to DB11.																																															
		ADS 10	The 10 most significant bits of the 12 bit digital data are output to DB0 to DB9.																																															
		ADS 8	The 8 most significant bits of the 12 bit digital data are output to DB0 to DB7.																																															
Comment	<p>The camera can select the number of digital output bit and the position of MSB.</p> <p>- 8,n (8 bit digital output) : ADS 8,n (n=8,9,10,11,12)</p> <div style="text-align: center;"> <p>Input Digital data Output Digital data</p> <table style="margin: auto;"> <tr><td>n=12</td><td>2¹¹</td><td></td><td>DBG7</td></tr> <tr><td>n=11</td><td>2¹⁰</td><td></td><td>DBG6</td></tr> <tr><td>n=10</td><td>2⁹</td><td></td><td>DBG5</td></tr> <tr><td>n=9</td><td>2⁸</td><td></td><td>DBG4</td></tr> <tr><td>n=8</td><td>2⁷</td><td></td><td>DBG3</td></tr> <tr><td>n=7</td><td>2⁶</td><td></td><td>DBG2</td></tr> <tr><td>n=6</td><td>2⁵</td><td></td><td>DBG1</td></tr> <tr><td>n=5</td><td>2⁴</td><td></td><td>DBG0</td></tr> <tr><td>n=4</td><td>2³</td><td></td><td></td></tr> <tr><td>n=3</td><td>2²</td><td></td><td></td></tr> <tr><td>n=2</td><td>2¹</td><td></td><td></td></tr> <tr><td>n=1</td><td>2⁰</td><td></td><td></td></tr> </table> <p>ADS 8,8 Blue data</p> </div>		n=12	2 ¹¹		DBG7	n=11	2 ¹⁰		DBG6	n=10	2 ⁹		DBG5	n=9	2 ⁸		DBG4	n=8	2 ⁷		DBG3	n=7	2 ⁶		DBG2	n=6	2 ⁵		DBG1	n=5	2 ⁴		DBG0	n=4	2 ³			n=3	2 ²			n=2	2 ¹			n=1	2 ⁰		
n=12	2 ¹¹		DBG7																																															
n=11	2 ¹⁰		DBG6																																															
n=10	2 ⁹		DBG5																																															
n=9	2 ⁸		DBG4																																															
n=8	2 ⁷		DBG3																																															
n=7	2 ⁶		DBG2																																															
n=6	2 ⁵		DBG1																																															
n=5	2 ⁴		DBG0																																															
n=4	2 ³																																																	
n=3	2 ²																																																	
n=2	2 ¹																																																	
n=1	2 ⁰																																																	

TNS	(CCD Tap Number Select)		
	Parameter	1 (Single)/2 (Dual)	
	Function	Selects single or Dual.	
	Example	TNS 1	CCD output is single mode.
		TNS 2	CCD output is Dual mode.

(2) Parameter setting commands

SHT	(SHutter Time)																
	Parameter	n (n: Horizontal line count) <table style="margin-left: 20px; border: none;"> <thead> <tr> <th></th> <th>Single output</th> <th>Dual output</th> </tr> </thead> <tbody> <tr> <td>·Normal readout</td> <td>: 1 to 40432</td> <td>1 to 74258</td> </tr> <tr> <td>·2×2 binning readout</td> <td>: 1 to 38413</td> <td>1 to 67721</td> </tr> <tr> <td>·4×4 binning readout</td> <td>: 1 to 34803</td> <td>1 to 57252</td> </tr> <tr> <td>·8×8 binning readout</td> <td>: 1 to 29297</td> <td>1 to 43732</td> </tr> </tbody> </table>		Single output	Dual output	·Normal readout	: 1 to 40432	1 to 74258	·2×2 binning readout	: 1 to 38413	1 to 67721	·4×4 binning readout	: 1 to 34803	1 to 57252	·8×8 binning readout	: 1 to 29297	1 to 43732
		Single output	Dual output														
·Normal readout	: 1 to 40432	1 to 74258															
·2×2 binning readout	: 1 to 38413	1 to 67721															
·4×4 binning readout	: 1 to 34803	1 to 57252															
·8×8 binning readout	: 1 to 29297	1 to 43732															
Function	Sets the exposure time in units of 1 H when the exposure trigger timing is controlled internally and the electronic shutter is selected as the method for setting the exposure time.																
EST	(External Shutter Time)																
	Parameter	n (n: Horizontal line count) <table style="margin-left: 20px; border: none;"> <thead> <tr> <th></th> <th>Single output</th> <th>Dual output</th> </tr> </thead> <tbody> <tr> <td>·Normal readout</td> <td>: 1 to 40432</td> <td>1 to 74258</td> </tr> <tr> <td>·2×2 binning readout</td> <td>: 1 to 38413</td> <td>1 to 67721</td> </tr> <tr> <td>·4×4 binning readout</td> <td>: 1 to 34803</td> <td>1 to 57252</td> </tr> <tr> <td>·8×8 binning readout</td> <td>: 1 to 29297</td> <td>1 to 43732</td> </tr> </tbody> </table>		Single output	Dual output	·Normal readout	: 1 to 40432	1 to 74258	·2×2 binning readout	: 1 to 38413	1 to 67721	·4×4 binning readout	: 1 to 34803	1 to 57252	·8×8 binning readout	: 1 to 29297	1 to 43732
		Single output	Dual output														
·Normal readout	: 1 to 40432	1 to 74258															
·2×2 binning readout	: 1 to 38413	1 to 67721															
·4×4 binning readout	: 1 to 34803	1 to 57252															
·8×8 binning readout	: 1 to 29297	1 to 43732															
Function	Sets the exposure time in units of 1 H when the exposure trigger timing is controlled externally and the internal settings for exposure time are used.																
AET	(Acquire Exposure Time)																
	Parameter	SS. xxxxxx (ss : value of seconds, xxxxxx: value of microseconds) xx s (s : seconds) xx ms (ms : milliseconds) xx us (us : microseconds)															
	Function	Sets the exposure time by using the time when Free running mode or the internal setting of External control mode. The exposure time of 33 μs or less and 1 s or more cannot be set.															
	Example	<table style="border: none;"> <tr> <td style="border: none;">AET 0. 123</td> <td style="border: none;">Sets the exposure time at 123 ms.</td> </tr> <tr> <td style="border: none;">AET 123ms</td> <td style="border: none;">Sets the exposure time at 123 ms.</td> </tr> </table>	AET 0. 123	Sets the exposure time at 123 ms.	AET 123ms	Sets the exposure time at 123 ms.											
AET 0. 123	Sets the exposure time at 123 ms.																
AET 123ms	Sets the exposure time at 123 ms.																
ATP	(Active Trigger Polarity)																
	Parameter	N (Negative)/P (Positive)															
	Function	Selects either Negative or Positive for the external trigger pulse polarity.															
	Example	<table style="border: none;"> <tr> <td style="border: none;">ATP N</td> <td style="border: none;">Sets the external trigger pulse polarity to Negative.</td> </tr> <tr> <td style="border: none;">ATP P</td> <td style="border: none;">Sets the external trigger pulse polarity to Positive.</td> </tr> </table>	ATP N	Sets the external trigger pulse polarity to Negative.	ATP P	Sets the external trigger pulse polarity to Positive.											
ATP N	Sets the external trigger pulse polarity to Negative.																
ATP P	Sets the external trigger pulse polarity to Positive.																
SPX	(Super Pixel X)																
	Parameter	1(1×1)/2(2×2)/4(4×4)/8(8×8)															
	Function	Selects 2×2, 4×4 or 8×8 super pixel readout when binning readout is selected as the scan mode.															
	Example	<table style="border: none;"> <tr> <td style="border: none;">SPX 2</td> <td style="border: none;">The mode setting command is executed, and the readout is set to 2×2 binning readout.</td> </tr> <tr> <td style="border: none;">SPX 4</td> <td style="border: none;">The mode setting command is executed, and the readout is set to 4×4 binning readout.</td> </tr> <tr> <td style="border: none;">SPX 8</td> <td style="border: none;">The mode setting command is executed, and the readout is set to 8×8 binning readout.</td> </tr> </table>	SPX 2	The mode setting command is executed, and the readout is set to 2×2 binning readout.	SPX 4	The mode setting command is executed, and the readout is set to 4×4 binning readout.	SPX 8	The mode setting command is executed, and the readout is set to 8×8 binning readout.									
SPX 2	The mode setting command is executed, and the readout is set to 2×2 binning readout.																
SPX 4	The mode setting command is executed, and the readout is set to 4×4 binning readout.																
SPX 8	The mode setting command is executed, and the readout is set to 8×8 binning readout.																

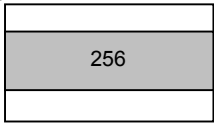
SV0	(Scan V-Offset)	
	Parameter	n ($0 \leq n \leq 472$, $n = \text{multiples of } 8$)
	Function	Set the vertical start address for the sub-array readout. When the n value is set to a number that is not a multiple of 8, the command elicits an error (E3) in response.
SVW	(Scan V-Width)	
	Parameter	m ($8 \leq m \leq 480$, $m = \text{multiples of } 8$)
	Function	Set the vertical line width for the sub-array readout. When the m value is set to a number that is not a multiple of 8, the command elicits an error (E3) in response.
	Example	Offset 64 (start address 64) 64 Width 256 SV0 64 SVW 256 SMD A 
SLP	(Scan Line Position)	
	Function	$y_1, y_2, y_3, y_4, y_5, y_6, y_7, y_8, y_9, y_{10}, y_{11}, y_{12}, y_{13}, y_{14}, y_{15}, y_{16}$ ($0 \leq y_1 \dots y_{16} \leq 479$, Parameters after y_2 can be omitted.)
	Example	Sets the readout line for the line scan readout. The readout line can be specified freely from 1 line to 16 lines.
ESC	(External trigger Source)	
	Parameter	M (Multi Timing I/O)/I (I/F)
	Function	Selects the input connector for external control pulse.

(3) Correctional commands

CEG	(Contrast Enhance Gain)				
	Parameter	n ($0 \leq n \leq 15$)			
	Function	Sets the gain for the contrast enhancement function.			
	Example	<table border="1"> <tr> <td>CEG 0</td> <td>Sets the gain to Low. (0 dB)</td> </tr> <tr> <td>CEG 15</td> <td>Sets the gain to High. (14 dB)</td> </tr> </table>	CEG 0	Sets the gain to Low. (0 dB)	CEG 15
CEG 0	Sets the gain to Low. (0 dB)				
CEG 15	Sets the gain to High. (14 dB)				

(4) Other setting commands

INI	(INItialize)		
	Parameter	None	
	Function	Initializes the contents of camera's internal parameter RAM.	
RES	(RESponse)		
	Parameter	Y (Yes)/N (No)	
	Function	Determines whether or not responses are returned when commands are executed.	
	Example	RES Y	Responses are returned when command are executed.
		RES N	Responses are not returned when command are executed.

(5) Status commands

Status commands return the current settings values.

Commands	Return value
?AMD (read Acquire MoDe)	N/E
?NMD (read Normal MoDe)	N/S/T
?EMD (read External MoDe)	E/L/T/f
?SMD (read Scan MoDe)	N/S/A
?ADS (read A/D Select)	12/10/8
?TNS (read CCD Tap Number Select)	1/2
?SHT (read Shutter Time)	n
?EST (read External ShutterTime)	n
?AET (read Acquire Exposure Time)	ss. xxxxxx
?ATP (read Acquire Trigger Polarity)	N/P
?SPX (read Super Pixel X)	1/2/4/8
?SV0 (read Scan V-Offset)	n (0 to 472)
?SVW (read Scan V-Width)	m (8 to 480)
?SLP (read Set Line Position)	y1, ..., y16
?ESC (read External trigger SourCe)	M/I
?CEG (read Contrast Enhancement Gain)	n (0 to 15)
?RES (read RESponse)	Y/N

The following command is a special status command not in the group of setting commands.

?VER	(read ROM VERsion)	
	Function	Returns the version of the camera's internal ROM.
	Return value	x.xx
?I NF	(read INFormation)	
	Function	Returns the information of the camera's Firmware and Timing generator.
	Return value	x.xx - y.yy (x.xx: Firmware y.yy: Timing generator)

(6) Obtaining camera hardware information commands

This command returns information about the camera hardware. This command differs from other status commands, in that it includes parameters.

?CAI	(CAmera Information)	
	Parameter	T : Camera type name H : CCD effective horizontal pixel count V : CCD effective vertical pixel count A : Output bit count I : A/D converter bit count O : Camera options B : Binning count
	Example	?CAI H → CAI H 640

11. PRECAUTIONS WHEN USING THE CCD

The camera uses a CCD. Careful attention must be paid to the following points when using a CCD:

(1) White spots

Subjecting the CCD to extended exposures may cause failure in part of the silicon wafer, resulting in white spots. This phenomenon is not currently preventable. If the CCD is at a fixed temperature, recurrence of the white spot increases proportionally with the exposure time, so this can be rectified with dark subtraction*. Atomic ray may generate white spot.

Note

- Regarding the specifications at the shipment, please refer to section 14-3.

(2) Smear

This is a phenomenon whereby bright vertical striations (vertical smear) appear on the images of bright objects. This is caused by vertical charge leakage in the CCD. The amount of smear is dependent on scan time and exposure time.

Impact from smear is not an issue for the camera in normal frame blanking mode, but sometimes becomes an issue when exposure time is shortened in electronic shutter and external exposure time modes.

(3) Folding distortion

A rough-edged flicker may be visible when imaging striped patterns, lines, and similar subject matter.

(4) Interference fringes pattern

Coherent light such as LASER light may generate interference fringes pattern on image.

(5) Over light



CAUTION

- Be careful not to input too strong light such as high-energy laser into CCD chip because CCD chip may be damaged by over light.

(6) Dual readout mode

Note

- Dual readout mode uses two-separated readout Amp whose performance is not perfectly same. Due to the readout Amp characteristics variation, you may see little intensity gap between right side and left side in one image even though the fine adjustment is done at factory before shipping. Single readout mode is recommended to achieve the best possible image quality.

* After acquiring an image using an arbitrary exposure time, the CCD is placed in a dark state for an equal amount of time, and reacquires the image without any light exposure. Subsequently, the second image is subtracted from the first, canceling dark-area information from the original image.

12. MAINTENANCE

12-1 CARE

Clean the exterior with a soft, dry cloth.



- Do not use a wet cloth, dirty cloth.

13. TROUBLESHOOTING CHECKLIST

If an abnormality occurs, look up the possible causes in the following tables and, if necessary, report the details to Hamamatsu subsidiary or local distributor.

13-1 IMAGE NOT TRANSFERRED

Cause	Measures	Chapter
Cables not fully connected.	Reconnect.	7
Camera control register not correctly configured.	Recheck register settings.	
Short in cables.	Replace cables.	

13-2 ALTHOUGH IMAGES ARE TRANSFERRED

(1) Scratches or discoloration visible on the screen

Cause	Measures	Chapter
Dirty the lens	Wipe the lens.	
Front glass of camera dirty.	Wipe with gauze dampened with alcohol.	

(2) Image is blurred.

Cause	Measures	Chapter
Incorrect back focus.	Contact Hamamatsu subsidiary or distributor.	17
Dirty the CCD chip.		

(3) Only dark, shaded images output.

Cause	Measures	Chapter
Lens mount cap left on.	Remove the cap.	

(4) All image overflowing.

Cause	Measures	Chapter
Too much light.	Reduce amount of light.	
Contrast enhancement set too high.	Lower gain.	

(5) Noise in image

Cause	Measures	Chapter
Noise introduced from exterior.	Find and remedy problem.	
Poor connection of internal components.	Contact Hamamatsu subsidiary or distributor.	17
Bad circuitry.		

14. SPECIFICATIONS

14-1 CAMERA SPECIFICATIONS

(1) Electrical specifications

Imaging device		Progressive scan interline CCD	
Effective number of pixels		640 (H) × 480 (V)	
Cell size		7.4 μm × 7.4 μm (Square size)	
Effective area		4.73 mm × 3.55 mm	
Frame rate	Normal readout	Single	82.0 Hz
		Dual	150.6 Hz
	2×2 binning readout	Single	155.5 Hz
		Dual	274.2 Hz
	4×4 binning readout	Single	280.7 Hz
		Dual	461.7 Hz
	8×8 binning readout	Single	465.0 Hz
		Dual	694.2 Hz
Readout noise		20 electrons (typ.) ^{*1}	
A/D converter		12 bit	
Lens mount		C-mount	
Amp gain conversion factor ^{*2}		5.0 electrons /ADcounts	
Full well capacity		20 000 electrons	
Contrast enhancement		0 dB to 14 dB (16 step)	
Exposure time setting		33.1 μs to 1 s	

(2) Operating environment

Ambient storage temperature	-10 °C to + 50 °C
Ambient operation temperature	0 °C to + 40 °C
Ambient operating humidity	70 % or less (no condensation)
Operating space	Indoor, altitude up to 2 000 m

(3) Dimensional outlines and weight

Camera	Approx. 0.73 kg (not including cables and accessories)
--------	---

Note

- Please see Chapter 15 Dimensional outlines.

(4) Applicable standards

EMC	EN61326: 1997 + A1: 1998 + A2: 2001 + A3: 2003	Class A
-----	--	---------

^{*1} This value is the measurement in free running mode and scan mode [normal readout]. The value was measured with the CCD in dark state. In this state, two images are acquired, image subtraction performed, the standard deviation taken from the results, and this value was then squared and plugged into a transformation coefficient.

^{*2} When running an amp-gain transformation coefficient to convert measured image count values into electrons, be sure to conduct dark subtraction first. The conversion efficiency is the value at the linearity correction ON.

14-2 SPECTRAL RESPONSE CHARACTERISTICS

Following is the typical spectral characteristics of the CCD.

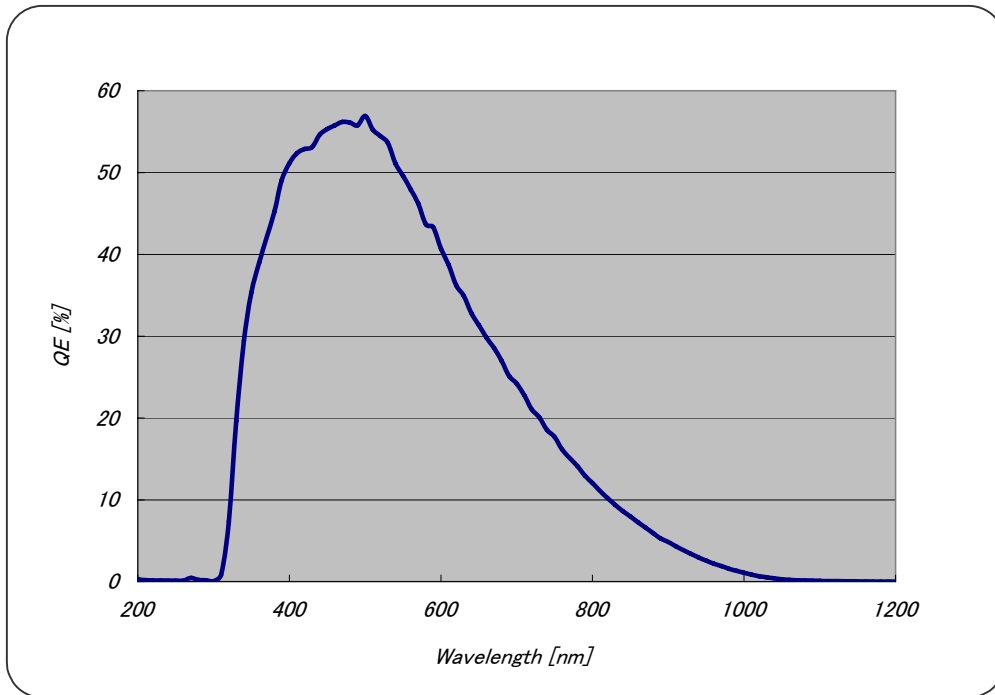

14-3 CAMERALINK INTERFACE SPECIFICATIONS

14-3-1 CAMERALINK INTERFACE

CameraLink interface is a standard of a standard digital interface for industrial application standardized by digital camera manufactures and frame grabber board manufactures. 28 bits digital data (TX0 to TX27) can be transferred as being changed into 5 signals (X0, X1, X2, X3, XCLK) by parallel serial transformation. This camera is based on CameraLink interface and Base Configuration 12 bit digital camera standard.

(1) CameraLink connector pin assignment (MDR-26)

Camera connector	Frame grabber connector	Channel Link signal
1	1	Inner Shield
2	25	X0-
3	24	X1-
4	23	X2-
5	22	Xclk-
6	21	X3-
7	20	SerTC+
8	19	SerTFG-
9	18	CC1-
10	17	CC2+
11	16	CC3-
12	15	CC4+
13	13	Inner Shield
14	14	Inner Shield
15	12	X0+
16	11	X1+
17	10	X2+
18	9	Xclk+
19	8	X3+
20	7	SerTC-
21	6	SerTFG+
22	5	CC1+
23	4	CC2-
24	3	CC3+
25	2	CC4-
26	26	Inner Shield

Note

- CC1 to CC4 are options. It is possible to use an external trigger. So when it is needed, please feel free to contact Hamamatsu subsidiary or local distributor.

(2) CameraLink bit assignment

28 bit solution pin name	Input signal name
TX0	DB0 LEFT
TX1	DB1 LEFT
TX2	DB2 LEFT
TX3	DB3 LEFT
TX4	DB4 LEFT
TX5	DB7 LEFT
TX6	DB5 LEFT
TX7	DB8 LEFT
TX8	DB9 LEFT
TX9	DB10 LEFT
TX10	DB10 RIGHT
TX11	DB11 RIGHT
TX12	DB11 LEFT
TX13	DB8 RIGHT
TX14	DB9 RIGHT
TX15	DB0 RIGHT
TX16	DB6 RIGHT
TX17	DB7 RIGHT
TX18	DB1 RIGHT
TX19	DB2 RIGHT
TX20	DB3 RIGHT
TX21	DB4 RIGHT
TX22	DB5 RIGHT
TX23	Spare
TX24	LVAL
TX25	FVAL
TX26	DVAL
TX27	DB6 LEFT

- **DVAL (Data valid signal)**
This signal synchronizes in the image data from CCD, and it is outputted. Each digital data is effective with the period of "ON" of this signal.
- **LVAL (Line valid signal)**
This signal show the period during which the line part of the image data from the CCD is in effect. This is "ON" when during the period the line is active.
- **FVAL (Frame valid signal)**
This signal shows the period during which the vertical part of the image data from the CCD is in effect. This is "ON" during the period the frame is active.
- **DB0 to DB11 (Digital image data)**
This is the image signal data from the CCD converted A/D. DB0 is the LSB (least significant bit) and DB11 is the MSB (most significant bit).

14-3-2 TIMING I/O CONNECTOR PIN ASSIGNMENTS [TIMING I/O]

The camera uses HIROSE model HR10A-7R-6S connector for inputting the external trigger pulse when the camera is operated in external control mode. Input should be TTL level, and the external trigger pulse polarity can be set either to negative or positive.

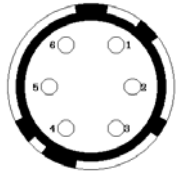
No.	Signal	Pin connections
1	Ext.Trigger	 HR10A-7R-6S
2	Digital GND	
3	SG output	
4	Digital GND	
5	NC	
6	Digital GND	



- Do not connect anything to pins 5 and 6.

14-3-3 CAMERA CONNECTOR PIN ASSIGNMENT [POWER]

The camera employs HIROSE mode HR10A-10R-12PB connectors.

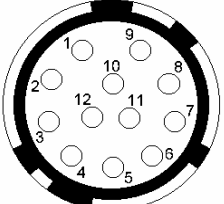
No.	Signal	Pin connections
1	GND (Camera)	 HR10A-10R-12PB
2	12 V (Camera)	
3	NC	
4	NC	
5	NC	
6	NC	
7	NC	
8	NC	
9	NC	
10	NC	
11	NC	
12	NC	

14-4 IMAGE DATA OUTPUT TIMING SPECIFICATIONS

(1) Line timing [LVAL]

The following is the relationship the line valid timing signal (LVAL) and the data valid signal (DVAL).

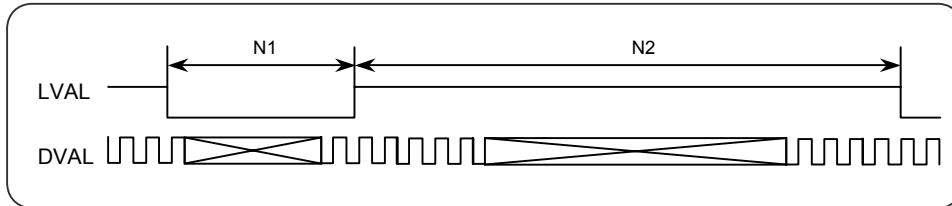

Scan mode		Normal	2×2 binning	4×4 binning	8×8 binning
N1 pixel count	Single	102	71	56	48
	Dual	84	62	51	46
N2 pixel count	Single	640	320	160	80
	Dual	320	160	80	40

(2) Frame timing [FVAL]

The following is the relationship the frame valid timing signal (FVAL) and the line valid timing signal (LVAL).

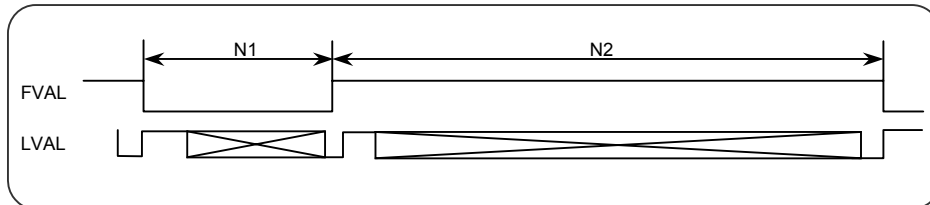

Scan mode		Normal	2×2 binning	4×4 binning	8×8 binning
N1 line number		13	7	4	3
N2 line number		480	240	120	60

15. DIMENSIONAL OUTLINES

15-1 CAMERA

(Unit: mm)

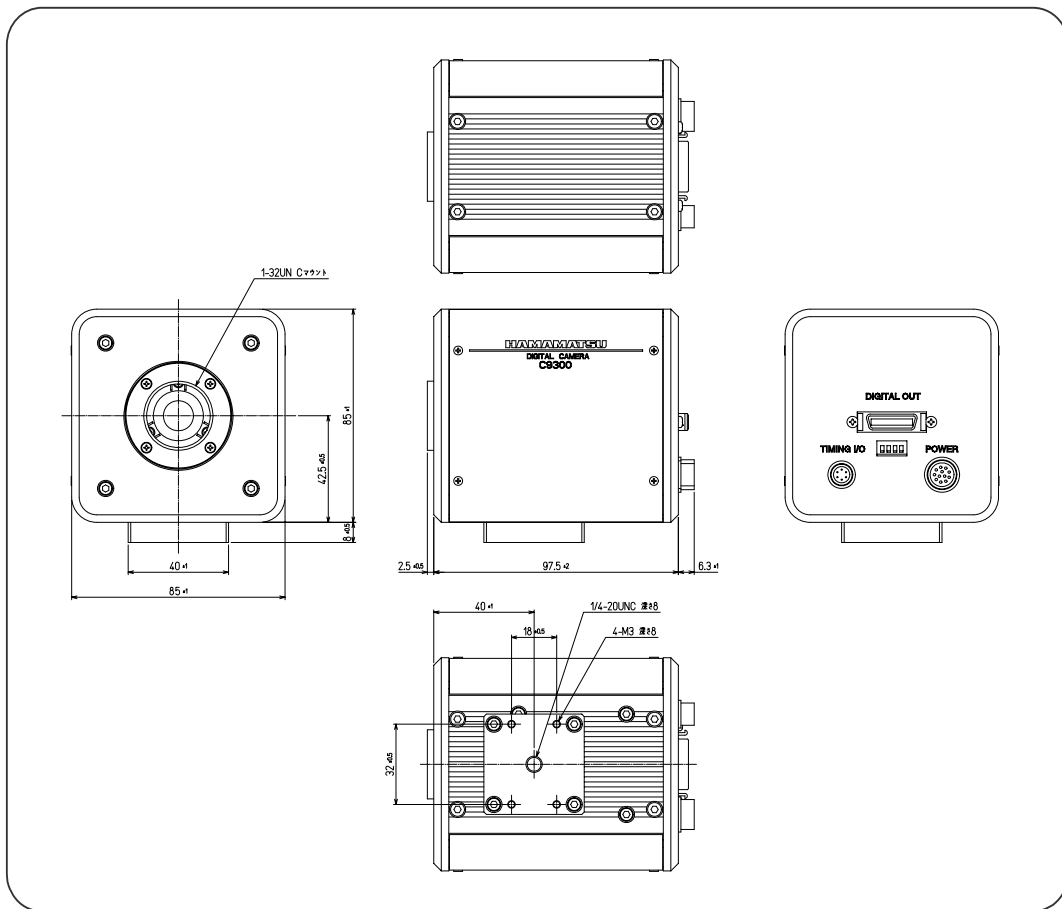

16. WARRANTY

Hamamatsu Photonics have fully inspected this camera and checked that its performance conforms to specifications. In the unlikely event of breakdown or other malfunction, contact Hamamatsu subsidiary or local distributor.

- (1) Unless otherwise stated by Hamamatsu subsidiary or local distributor, this system is under warranty for 12 months from the delivery date.
 - Consumable parts, such as a fan, a mechanical shutter, and a fuse, are excepted.
 - Degradation with atomic rays, the radiation (X-rays, gamma rays, UV light, etc.) of CCD is excepted.
- (2) The warranty only covers defects in the materials and manufacturing of the system. You may be liable for repairs during the warranty period in the event of a natural disaster or if you handle the system contrary to the instructions in this manual, use it without due caution, or try to modify it.
- (3) We will repair the system or replace it, subject to availability, free of charge within the terms of the warranty.

REPAIRS

- (1) If you notice anything wrong with the camera, confirm whether or not it is malfunctioning by referring to the troubleshooting checklist in this instruction manual. You must first clarify the symptoms in order to avoid any misunderstanding or error.
- (2) If you have any trouble or are unclear about anything, contact Hamamatsu subsidiary or local distributor giving the product name, serial number and details of the problem. If Hamamatsu Photonics consider the problem to be a malfunction, we will decide whether dispatch an engineer or have the camera returned to us for repairs.

17. CONTACT INFORMATION

Japan

HAMAMATSU PHOTONICS K. K., Systems Division

812 Joko-cho, Higashi-ku, Hamamatsu City, 431-3196, Japan
 Telephone (81) 53-431-0124, Fax: (81) 53-435-1574
 E-mail: export@sys.hpk.co.jp

U.S.A. and Canada

Hamamatsu Corporation, Systems Division

360 Foothill Road, Bridgewater, N.J. 08807-0910, U.S.A.
 Telephone: (1)908-231-1116, Fax: (1)908-231-0852
 E-mail: usa@hamamatsu.com

Germany

Hamamatsu Photonics Deutschland GmbH

Arzbergerstr. 10, D-82211 Herrsching am Ammersee, Germany
 Telephone: (49) 8152-375-0, Fax: (49) 8152-265-8
 E-mail: info@hamamatsu.de

France

Hamamatsu Photonics France S.A.R.L.

19, Rue du Saule Trapu, Parc du Moulin de Massy, 91882 Massy Cedex,
 France
 Telephone: (33) 1 69 53 71 00, Fax: (33) 1 69 53 71 10
 E-mail: infos@hamamatsu.fr

United Kingdom

Hamamatsu Photonics UK Limited

2 Howard Court, 10 Tewin Road, Welwyn Garden City Hertfordshire
 AL7 1BW, United Kingdom
 Telephone: (44) 1707-294888, Fax: (44) 1707-325777
 E-mail: info@hamamatsu.co.uk

North Europe

Hamamatsu Photonics Norden AB

Smidesvagän 12, SE-171 41 Solna, Sweden
 Telephone: (46) 8-509-031-00, Fax: (46)8-509-031-01
 E-mail: info@hamamatsu.se

Italy

Hamamatsu Photonics Italia S.R.L.

Strada della Moia, 1/E 20020 Arese (Milano), Italy
 Telephone: (39) 02-935 81 733, Fax: (39) 02-935 81 741
 E-mail: info@hamamatsu.it

- *The contents of this manual are subject to change without notice.*
- *The unauthorized reproduction or distribution of parts or all of this manual is prohibited.*
- *If one of the following problems occurs, please contact Hamamatsu Photonics.
 (See the CONTACT INFORMATION.) We will deal with the problem immediately.*
 - *Some contents of the manual are dubious, incorrect or missing.*
 - *Some pages of the manual are missing or in the wrong order.*
 - *The manual is missing or dirty.*