

Electron Multiplier CCD Camera C9100-02 Instruction Manual

Thank you for your purchase.



CAUTION

- Follow the safety precautions in Chapter 1 in order to avoid personal injury and damage to property when using this camera. The manual describes the correct handling method of C9100 camera and provides cautions in order to avoid accidents. **Read this manual carefully** beforehand use the camera correctly. After reading the manual, store it in a location where you can refer to it at any time.







Ver. 1.7
April 2007

HAMAMATSU PHOTONICS K.K.

1. SAFETY PRECAUTIONS

1-1 CLASSIFICATION OF WARNINGS

We have classified the warning symbols that appear in this operating manual and on the camera as follows for better comprehension of their meaning. Make sure that you fully understand them and obey the instructions they contain.

 WARNING	Improper handling of the camera without observing these warnings could lead to serious injury to the user and even death.
 CAUTION	Improper handling of the camera without observing these cautions could lead to personal injury to the user or damage to property.
 Note	This symbol indicates a note to help you get the best performance from the camera. Read the contents of the note carefully to ensure correct and safe use. Failure to observe one of these notes might impair the performance of the camera.
	This symbol indicates a cautionary item that should be obeyed when handling the camera. Read the contents carefully to ensure correct and safe use.
	This symbol indicates an action that is forbidden. Read the contents carefully and be sure to obey them.
	This symbol indicates a compulsory action or instruction. Read the contents carefully and be sure to obey them.

 **WARNING**



Power supply

Use the camera with the voltage indicated on the rating. Using a different voltage can damage the camera and lead to fire or electric shock.



Cables

Be careful not to place heavy objects on cables or bend it excessively. Doing so can damage the cable and lead to fire or electric shock.



Do not attempt to dismantle or modify the camera

Doing so can also lead to damage and even injury, as some internal components become hot. Only touch parts as indicated in this manual.



Do not allow foreign objects such as combustible substances, metal objects or water to get inside the camera.

They can damage the camera and lead to fire or electric shock.



If an abnormality occurs,

such as the image suddenly disappearing or a strange noise, smell or see smoke coming from the camera, stop the power supply immediately and contact Hamamatsu subsidiary or local distributor. Never attempt to repair the camera yourself.

 **CAUTION****Connecting and disconnecting cables**

Always turn off the power before connecting and disconnecting cables.

**Affixing the camera**

When fitting the camera to a tripod or other fixture, use the screw (1/4-20UNC) in the center of a camera mount or the threaded sleeve (M3) about the mount's perimeter. Be careful not to allow the fitting screw to enter more than 5 mm from the surface of the mount. Screwing this in excessively may impair normal operation.

**Lenses**

Be careful not to screw the lens more than 7 mm onto the C-mount of the camera. Doing so can scratch the protective glass. (Some wide angle lenses in particular can have a thread of 7 mm or more.)

**Shipping precautions**

When transporting the camera by truck, ship, airplane, etc., wrap it securely in packaging material or something similar.

**Do not subject the camera to strong shocks**

Dropping the camera or other shocks can damage the camera.

**Disposal**

When disposing of the system, take appropriate measures in compliance with applicable regulations regarding waste disposal and correctly dispose of it yourself, or entrust disposal to a licensed industrial waste disposal company. In any case, be sure to comply with the regulations in your country, state, region or province to ensure the system is disposed of legally and correctly.

2. CHECK THE CONTENTS OF PACKAGE

When you open the package, check that the following items are included before use. If the contents are incorrect, insufficient, or damaged in any way, contact Hamamatsu subsidiary or local distributor without attempting to operate the camera.

C9100-02 camera	1
Lens mount cap (attached to the camera)	1
Camera mount	1
C9100-02 instruction manual (this booklet)	1

[Option]

AC adaptor (The accessories: Power supply Cord)	A3472-07
Camera cable (5 m)	A9189-05
CameraLink interface cable (5 m)	A9262-05

Note

- The cable listed in option is highly recommended for use with C9100 the camera. The camera system may not confirm to CE marking regulation if other type of cable is used with.

3. INSTALLATION



Avoid using or storing this camera in the following places

- Where the ambient temperature might fall below 0 °C or rise above 40 °C
- Where the temperature varies extremely
- In direct sunlight or near a heater
- Where the humidity is 70 % or more or where there is dripping water
- Close to a strong source of magnetism or radio waves
- Where there is vibration
- Where it might come into contact with corrosive gases (such as chlorine or fluorine)
- Where there is a lot of dust



Do not block ventilation openings

To prevent excessive internal temperature do not wrap cloth around the equipment while it is in operation. Make sure the blowholes on the side panels are not blocked. The blowholes must be at least 10 cm from the wall.

Contents

1. SAFETY PRECAUTIONS	1
1-1 CLASSIFICATION OF WARNINGS.....	1
2. CHECK THE CONTENTS OF PACKAGE	4
3. INSTALLATION	4
4. OVERVIEW	7
5. FEATURES	7
6. NAME AND FUNCTION OF THE PARTS	8
6-1 CAMERA.....	8
7. CONNECTING CABLES	10
8. OPERATION	11
8-1 PREPARATION FOR IMAGING.....	11
8-2 IMAGING.....	11
8-3 END OF IMAGING.....	11
9. IMAGE ACQUISITION	12
9-1 OVERVIEW OF THE CAMERA MODES.....	12
9-2 DETAIL OF THE CAMERA MODES.....	12
9-2-1 BINNING READOUT AND BINNING SETTINGS VALUES.....	12
10. PRECAUTIONS WHEN USING THE CCD	13
11. MAINTENANCE	14
11-1 CARE.....	14
12. TROUBLESHOOTING CHECKLIST	15
12-1 IMAGES NOT TRANSFERRED.....	15
12-2 ALTHOUGH IMAGES ARE TRANSFERRED.....	15
12-3 OTHER PROBLEMS.....	15
13. SPECIFICATIONS	16
13-1 CAMERA SPECIFICATIONS.....	16
13-2 SPECTRAL RESPONSE CHARACTERISTICS.....	18
13-3 EM GAIN.....	18
13-4 CAMERALINK INTERFACE SPECIFICATIONS.....	19
13-5 TIMING I/O SPECIFICATIONS.....	21
13-5-1 TIMING I/O CONNECTOR PIN ASSIGNMENTS [TIMING I/O].....	21
13-5-2 TRIGGER IN TIMINGS.....	22
13-5-3 INTEG OUT TIMINGS.....	24
13-6 POWER SPECIFICATIONS.....	25
14. DIMENSIONAL OUTLINE	26

14-1 CAMERA 26

15. WARRANTY 27

16. CONTACT INFORMATION 28

4. OVERVIEW

Electron Multiplier CCD Camera C9100 series is a new type of high sensitivity CCD camera that has special structure to get the electric gain on the CCD chip.

C9100 series has resolved the issues like the burning, afterglow, lifetime and low resolution, comparing to the ICCD camera and EB-CCD camera, and also offered the high sensitivity images on the similar level to the cameras with real time.

5. FEATURES

(1) High Gain

C9100-02 can amplify the electric charge with approximately 2000 times on the CCD chip and they can detect the objects that the general normal CCD cameras have not and offer the images with real time.

(2) Digital output

Image signals are converted from analog to digital in the AC adaptor and output externally as 14 bit digital data. (Transmission line length: Max.10 m, based on CameraLink.)

(3) Low image distortion

With the CCD, the pixels are arranged geometrically, virtually eliminating image distortion. And the image processing can be easily done for the measurement thanks to square pixels.

(4) No burn-in

The burning, which happens on an ICCD camera with an Image Intensifier, is not found on the Electron Multiplier CCD camera.

(5) Lens mount

C-mount used for the lens mount.

6. NAME AND FUNCTION OF THE PARTS

6-1 CAMERA

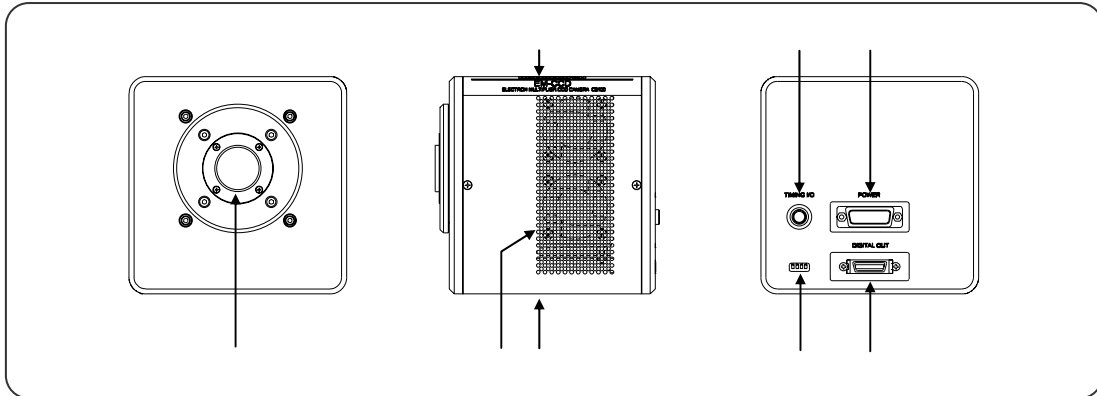

Fig.6-1

Lens mount

C-mount lens or optical system with C-mount can be attached.

Note

- C-mount has a depth of 7 mm. Screwing the lens too far into the camera may scratch the glass surface.

Blowhole

The fan circulates the air in order not to increase inside temperature.



- Do not block ventilation openings.

Screw holes to fix the camera (each four holes on the upside and downside)

When the camera is used with a tripod, the tripod attachment should be attached with the screw holes.



- Please set for the screws in order not to enter 5 mm or more.

Timing I/O connector [TIMING I/O]

This connector is used for input and output of timing signals when synchronizing with external equipment.

Camera connector [POWER]

This is for connecting a camera to an AC adaptor with a camera cable.

Note

- AC adaptor: A3472-07 is an option. As for the details of the AC adaptor, see the instruction manual of the product attachment separately.

Mode switching switch

This is a switch for the camera maintenance.



- All positions are set to "OFF". Do not change this.

CameraLink interface connector [DIGITAL OUT]

Connector used for connecting the camera to the CameraLink interface board.

7. CONNECTING CABLES

Refer to the figure below when connecting the various cables.

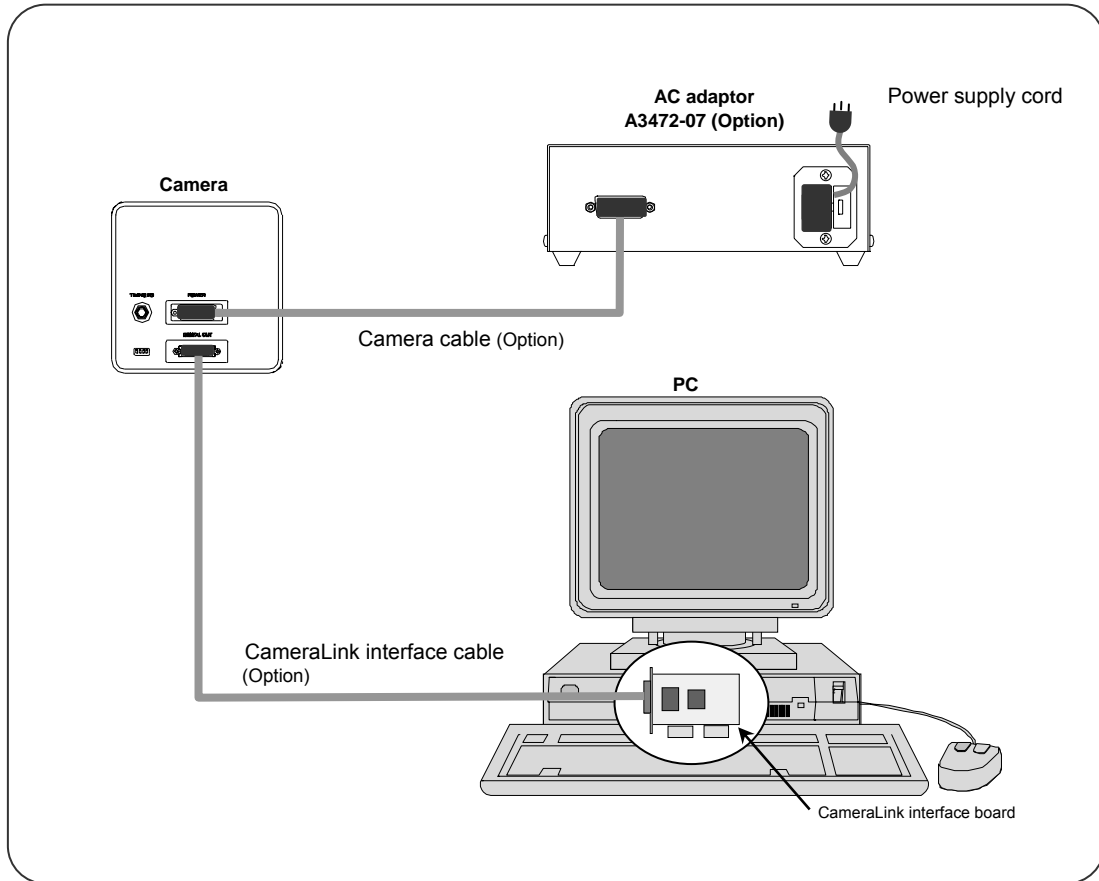

Fig.7-1



- When cables are connected, confirming the power switch is in the OFF position.

Camera cable (Option: A9189-05)

Camera used for connecting the camera to the AC adaptor.

CameraLink interface cable (Option: A9262-05)

Cable used for connecting the CameraLink interface connector to the CameraLink interface board mounted on the host computer.

Power supply cord (Option: The accessories of A3472-07)

Note

- Hamamatsu recommends optional interface for C9100.
 - AC adaptor A3472-07
 - Camera cable A9189-05
 - CameraLink interface cable A9262-05

Depending on type of interface cables, the C9100 may not keep CE marking compliance in terms of EMC directive.

8. OPERATION

8-1 PREPARATION FOR IMAGING

Use the following procedure when starting operating of the camera.

- (1) Connect the equipment as shown in Figure 7-1 before operating of the camera.
- (2) Switch the AC adaptor's power switch to ON.
- (3) After turning the power switch on, wait approximately 30 minutes for the temperature to stabilize; this completes preparation for imaging.



- Start the measurement after the inside cooling temperature becomes stable because the Electron Multiplier gain depends on the temperature.

8-2 IMAGING

Switch the power switch to ON.

Digital data output pixel count	1000×1000
Control mode	Internal control mode
Scan mode	Normal readout
Exposure time setting	32 ms
EM gain	Minimum (sensitivity = 0)
Digital data output bit count	14

Commands from the host computer are transmitted via the CameraLink interface, permitting changes to the modes and parameters.

8-3 END OF IMAGING

- (1) End imaging or transmission of image data with the control software when imaging is finished.
- (2) Turn off the power to the peripheral equipment.

Note

- Concerning the Beep;
The abnormal high temperature inside the camera makes the beep. Then turn off the power supply immediately. And turn on the power supply after removing the factors, which increase the temperature.

9. IMAGE ACQUISITION

This section describes the modes required when using the camera to obtain images.

9-1 OVERVIEW OF THE CAMERA MODES

This camera features many different operational modes. Furthermore, all modes involve the CameraLink interface's built-in microprocessor, providing control and setting for all modes. Of the numerous different modes, the modes used for obtaining images are broadly classified into the categories below.

(1) Internal control mode

Exposure and readout is performed repeatedly, controlled by the internal microprocessor. Some operations for which the commands can be used are shown below.

Scan modes	Normal readout/Binning readout/Sub-array readout
Exposure time setting	Norma/Frame blanking

(2) External control mode

An external control (trigger) pulse input the internal microprocessor and the repeating exposure and readout. Exposure start timing and length of exposure can be controlled with the external trigger pulse. Some operations for which the commands can be used are shown below. It includes two modes, Edge trigger mode*¹ and Level trigger mode*².

Scan modes	Normal readout/Binning readout/Sub-array readout
External control pulse polarity	Negative/Positive

* 1 The camera is stand-by and waits for external trigger input when the camera is set in this mode. When the external trigger signal is input, Electrical charges generated in CCD before the external trigger signal input is dumped out by High-speed readout. After that, the camera starts the accumulation of the electrical charge until the end of the exposure time, readout charged electrons and output digital data. The exposure time can be set by the command operations.

* 2 The camera is stand-by and waits for external trigger input when the camera is set in this mode. When the external trigger signal is input, Electrical charges generated in CCD before the external trigger signal input is dumped out by High-speed readout. After that, the camera starts the accumulation of the electrical charge until the end of the exposure time, readout charged electrons and output digital data. The exposure time can be set by the pulse width of the external trigger.

9-2 DETAIL OF THE CAMERA MODES

9-2-1 BINNING READOUT AND BINNING SETTINGS VALUES

In addition to the normal readout (1×1 binning readout), in which the digital output pixel count is read out as is, the following readouts are available.

Binning	Commands
2×2 binning readout: 2 horizontal pixels combined with 2 vertical pixels.	SMD S SPX 2
4×4 binning readout: 4 horizontal pixels combined with 4 vertical pixels.	SMD S SPX 4
8×8 binning readout: 8 horizontal pixels combined with 8 vertical pixels.	SMD S SPX 8
16×16 binning readout: 16 horizontal pixels combined with 16 vertical pixels.	SMD S SPX 16

10. PRECAUTIONS WHEN USING THE CCD

C9100 uses a CCD. Read the following points regarding handling of the CCD carefully.

(1) White spots

During long exposure times, imperfection in the CCD's silicon wafer cause white spots to be generated on the image. As of the present time, there is no workaround for this phenomenon. Certain CCD temperature characteristics can cause these white spots to multiple in relation to exposure time, but using dark subtraction* can compensate for this phenomenon. Atomic ray may generate white spot.

* After acquiring an image using an arbitrary exposure time, the CCD is placed in a dark state for an equal amount of time, and reacquires the image without any light exposure. Subsequently, the second image is subtracted from the first, canceling dark-area information from the original image.

(2) Smear

When imaging very bright objects, bright vertical stripes (vertical smear) may be visible in the images being taken. This is due to the incident light while transferring the electrons from sensor part to memory part. The amount of smear is dependent on (the ratio between) readout time and exposure time. Smear tends to appear more strongly at shorter exposure time to readout time.

Impact from smear is just a little for the camera in normal mode and frame blanking mode, but sometimes it is observed when exposure time is shortened to readout time in external control mode.

(3) Folding distortion

A rough-edged flicker may be visible when imaging striped patterns, lines, and similar subject matter.

(4) Interference fringes pattern

Coherent light such as LASER light may generate interference fringes pattern on image.

(5) Electron Multiplier gain (EM gain)

Start the measurement after the inside cooling temperature becomes stable because the Electron Multiplier gain depends on the temperature. The inside cooling temperature usually becomes stable after approximately 30 minutes.

When the EM gain is set higher, a part of output signal might show zero. When it is not good for the measurement, please use with the higher offset level.

(6) EM gain degradation

In order to maintain proper camera performance do not expose the CCD chip to excessive incident light or excessive EM gain. Turn off power when the C-mount is exchanged or incident light levels are too high.

This CCD chip has the following characteristics:

- 1) Higher EM gain creates greater EM gain shift down while maintaining the same incident light level.
- 2) Higher incident light levels create greater EM gain shift down while maintaining the same EM gain setting.

11. MAINTENANCE

11-1 CARE

Clean the exterior with a soft, dry cloth.



- Do not use a wet cloth, dirty cloth.

12. TROUBLESHOOTING CHECKLIST

If an abnormality occurs, look up the possible causes in the following tables and, if necessary, report the details to Hamamatsu subsidiary or local distributor.

12-1 IMAGES NOT TRANSFERRED

Cause	Measures	Chapter
Cables not fully connected.	Reconnect	7
Proper command not transferred to the camera.	Reconfirm command	
Short in cables.	Replace cable	

12-2 ALTHOUGH IMAGES ARE TRANSFERRED

(1) Scratches or discoloration visible on the screen

Cause	Measures	Chapter
Dirty lens.	Wipe lens	
Front glass of camera dirty.	Wipe with gauze dampened with alcohol.	

(2) Image is blurred

Cause	Measures	Chapter
Incorrect back focus.	Contact Hamamatsu subsidiary or distributor.	16
Dirty CCD chip.		

(3) Only dark, shaded images output

Cause	Measures	Chapter
Lens mount cap left on.	Remove the cap	
Too little light.	Adjust amount of light	
Too much light.		
EM gain set too low.	Adjust gain	
EM gain set too high.		

(4) All images overflowing

Cause	Measures	Chapter
Too much light.	Reduce amount of light.	
EM gain set too high.	Lower gain	

(5) Noise in image

Cause	Measures	Chapter
Noise introduced from exterior.	Find and remedy problem	
Poor connection of internal components.	Contact Hamamatsu subsidiary or distributor	16
Bad circuitry.		

12-3 OTHER PROBLEMS

(1) Buzzer

Cause	Measures	Chapter
The blowhole is covered.	Do not block ventilation openings	



CAUTION

- The abnormal high temperature inside the camera makes the beep. Then turn off the power supply immediately.

13. SPECIFICATIONS

13-1 CAMERA SPECIFICATIONS

(1) Electrical Specifications

Camera head type	Hermetic vacuum-sealed air-cooled head	
Imaging device	Frame transfer CCD	
Effective number of pixels	1000 (H) × 1000 (V)	
Cell size	8.0 μm (H) × 8.0 μm (V)	
Effective area	8.0 mm (H) × 8.0 mm (V)	
Pixel clock rate	35 MHz/pixel	
Readout noise (r.m.s.) typ.	at minimum EM gain	10 electrons * ¹
	at maximum EM gain	< 1 electron
Full well capacity typ.	70 000 electrons	
Minimum EM gain typ.	× 6	
Maximum EM gain typ.	× 2000 * ²	
Circuit gain conversion factor typ.	4.4 electrons/ADcounts * ³	
Cooling method	Forced-air peltier cooling with hermetic sealing* ⁴	
Cooling temperature	Absolute and stabilized to – 50 °C @ ambient room temperature 0 °C to + 40 °C	
A/D converter	14 bit	
Output Signal / External control	CameraLink	
Exposure time	100 μs to 10 s	
Electronic shutter	Yes	
Binning	Yes	
Sub-array	Yes	
External trigger	Yes	
Offset enhancement	Yes	
Contrast enhancement	No	
Lens mount	C-mount	
Power requirement	DC + 12 V	
Power consumption	Approx. 60 V·A	

* 1 This value is measured in internal control mode, normal readout scan mode, 32 ms exposure time, minimum EM gain and with no incident light. At first, the standard deviation is calculated from the image, which is made as the difference of two images taken in these conditions. Then this readout noise is given the result of the calculation dividing this standard deviation by square root of 2, multiply it by the circuit gain conversion factor and divided it by the value of minimum EM gain.

* 2 Even with electron multiplier gain maximum, dark signal is kept low level for low light imaging.

* 3 The circuit gain conversion factor is the calculated value of transformation coefficient, which is used to convert the measured image count values into the number of electrons on the multiplication register. The EM gain is necessary to it into the number of electrons in the image area. And the dark subtraction execution is necessary to use the gain conversion factor for calculation.

* 4 The hermetic sealed head maintains a high degree of vacuum 10^{-7} to 10^{-8} Torr, without re-evacuation.

(2) Frame rates

Frame rate of each binning and sub-array condition		Effective vertical width (Sub-array)						
		1000	512	256	128	64	32	16
Frame rate (frame/s)	1×1 binning readout	30.1	55.8	101.0	169.8	257.7	347.2	420.2
	2×2 binning readout	57.0	101.0	169.8	257.7	347.2	420.2	469.5
	4×4 binning readout	103.0	169.8	257.3	347.2	420.2	469.5	500.0
	8×8 binning readout	172.7	257.7	347.2	420.2	469.5	500.0	515.5
	16×16 binning readout	262.0	346.0	418.4	467.3	497.5	512.8	520.8

(3) Operating environment

Ambient operating temperature	0 °C to + 40 °C
Ambient storage temperature	-10 °C to + 50 °C
Ambient operating humidity	70 % or less (no condensation)
Operating space	Indoor, altitude up to 2000 m

(4) Dimensional outline and weight

Camera	Approx. 2500 g
--------	----------------

Note

- Please see Chapter 14 Dimensional outline.

(5) Applicable standards

EMC	EN61326: 1997 + A1:1998 + A2:2001+ A3:2003 Class A
-----	--

13-2 SPECTRAL RESPONSE CHARACTERISTICS

Following is the typical spectral characteristics of the CCD.

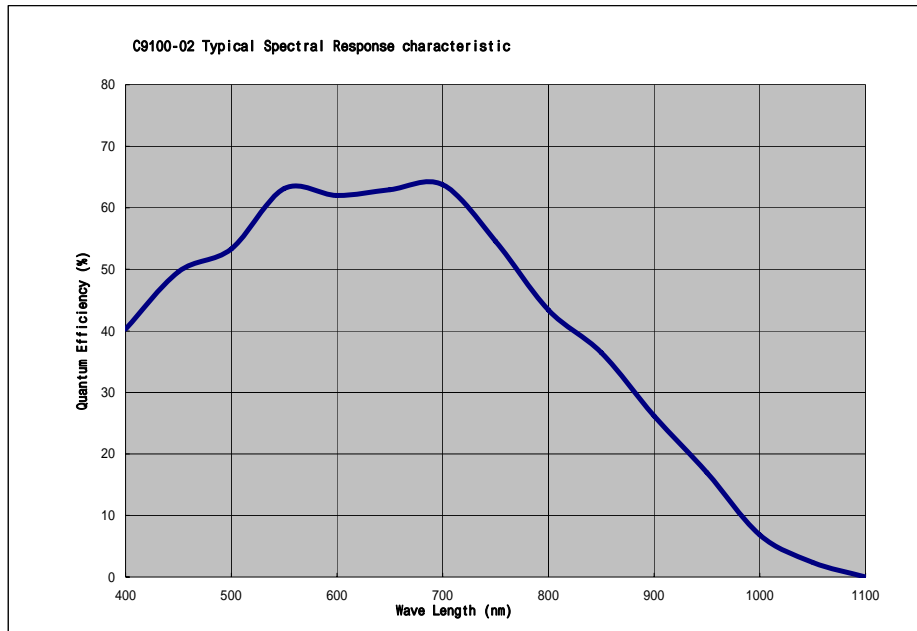

13-3 EM GAIN

Following is the setting value of SENSITIVITY and the typical EM gain.

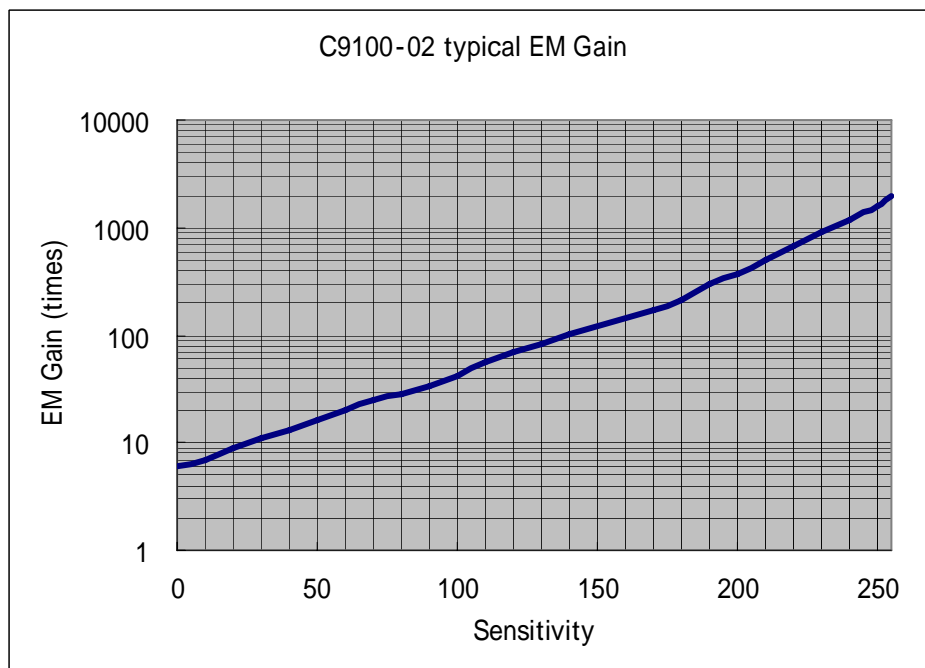

13-4 CAMERALINK INTERFACE SPECIFICATIONS

CameraLink interface is a standard of a digital interface for industrial application standardized by digital camera manufactures and frame grabber board manufactures. 28 bits digital data (TX0 to TX27) can be transferred as being changed into 5 signals (X0, X1, X2, X3 and XCLK) by parallel serial transformation. This camera is based on CameraLink interface and Base Configuration 14 bit digital camera standard.

(1) CameraLink connector pin assignments (MDR-26)

Camera connector	Frame grabber connector	Channel Link signal
1	1	Inner Shield
2	25	X0-
3	24	X1-
4	23	X2-
5	22	Xclk-
6	21	X3-
7	20	SerTC+
8	19	SerTFG-
9	18	CC1-
10	17	CC2+
11	16	CC3-
12	15	CC4+
13	13	Inner Shield
14	14	Inner Shield
15	12	X0+
16	11	X1+
17	10	X2+
18	9	Xclk+
19	8	X3+
20	7	SerTC-
21	6	SerTFG+
22	5	CC1+
23	4	CC2-
24	3	CC3+
25	2	CC4-
26	26	Inner Shield

Note

- CC1 to CC4 are options. It is possible to use an external trigger. So when it is needed, please feel free to contact our sales group.

Note

- SerTC and SerTFG are available when the second of DIPSW on the back panel of the camera is off.

(2) CameraLink bit assignments

28 bit Solution Pin Name	Input Signal Name
TX0	DB0
TX1	DB1
TX2	DB2
TX3	DB3
TX4	DB4
TX5	DB7
TX6	DB5
TX7	DB8
TX8	DB9
TX9	DB10
TX10	NC
TX11	NC
TX12	DB11
TX13	DB12
TX14	DB13
TX15	NC
TX16	NC
TX17	NC
TX18	NC
TX19	NC
TX20	NC
TX21	NC
TX22	NC
TX23	Spare
TX24	LVAL
TX25	FVAL
TX26	DVAL
TX27	DB6

DVAL (Data valid signal)

This signal synchronizes in the image data from CCD, and it is outputted. Each digital data is effective with the period of "ON" of this signal.

LVAL (Line valid signal)

This signal shows the period during which the line part of the image data from the CCD is in effect. This is "ON" when during the period the line is active.

FVAL (Frame valid signal)

This signal shows the period during which the vertical part of the image data from the CCD is in effect. This is "ON" during the period the frame is active.

DB0 to DB13 (Digital image data)

This is the image signal data from the CCD converted A/D. DB0 is the LSB (least significant bit) and DB13 is the MSB (most significant bit).

13-5 TIMING I/O SPECIFICATIONS

13-5-1 TIMING I/O CONNECTOR PIN ASSIGNMENTS [TIMING I/O]

C9100 uses Hirose model HR10A-7R-6S connector for input and output signals.

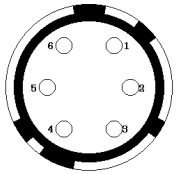
No.	Signal	Pin connections
1	Trigger In	 <p>HR10A-7R-6S</p>
2	Digital GND	
3	N.C.	
4	N.C.	
5	Integ Out	
6	Digital GND	

Trigger In: Input pin of the external trigger pulse.

Integ Out: Output pin of the integration-timing signal.

N.C. : Non-connection.

13-5-2 TRIGGER IN TIMINGS

Input the external trigger pulse when the camera is operated in External Control mode. The signal level is TTL level or C-MOS 3.3 V level (Termination is 680 Ω), and the external trigger pulse polarity can be set either to negative or positive. Minimum trigger pulse width is 1 μs in edge trigger mode and synchronous readout trigger mode or 100 μs in level trigger mode. The maximum trigger pulse width is 10 s in all modes. Regarding the fastest frame rate, see the fastest frame rate table in the chapter [13-1.CAMERA SPECIFICATIONS]. The normal operation is not warranted if the input trigger pulse condition is not in the above conditions.

(1) Edge trigger mode (pulse polarity is negative)

Trigger In cycle > Exposure time + Readout time

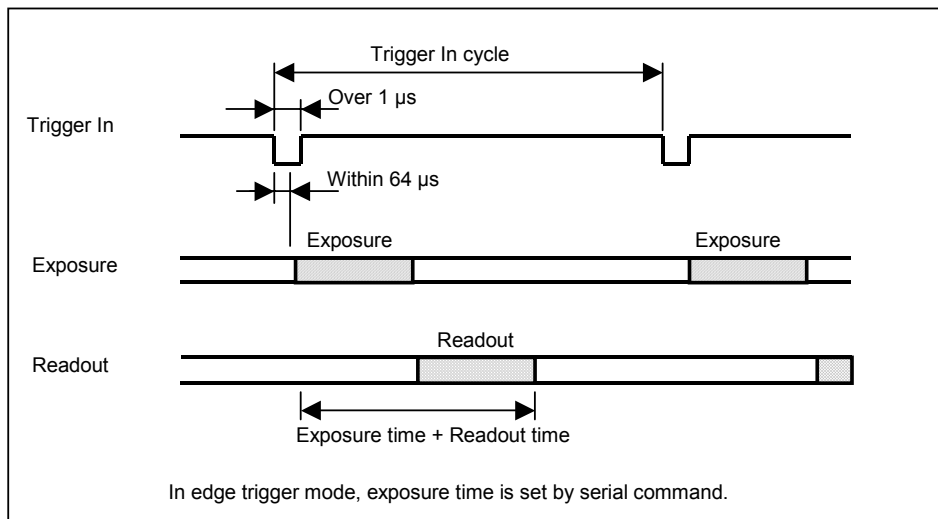

Trigger In cycle < Exposure time + Readout time (Cyclic trigger mode)

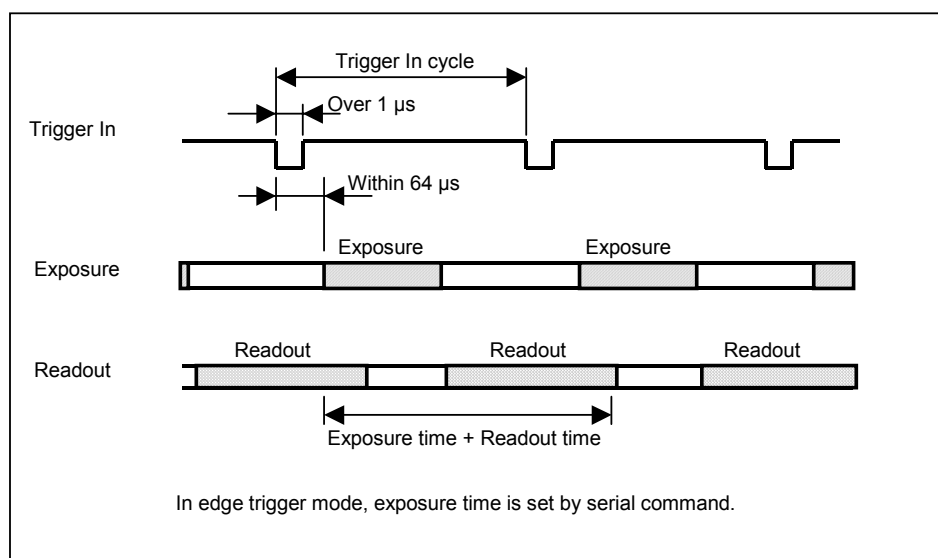

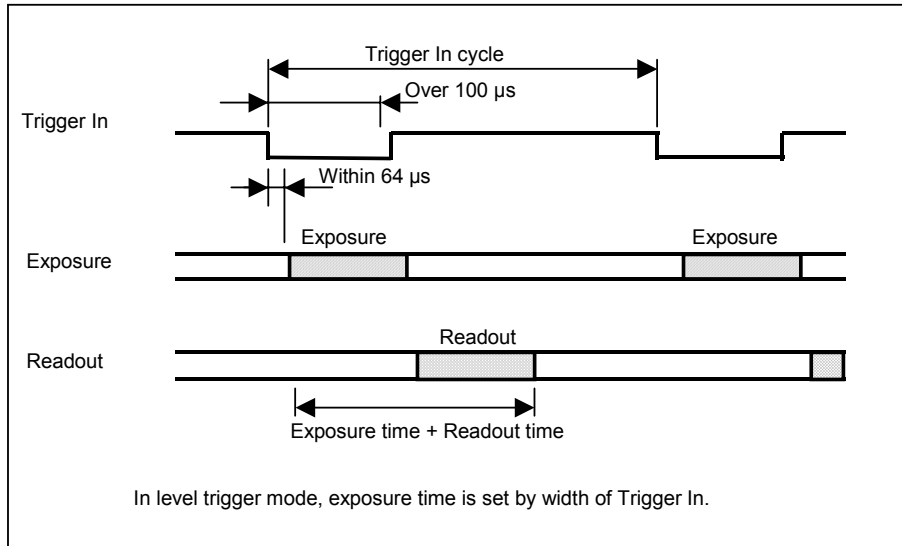
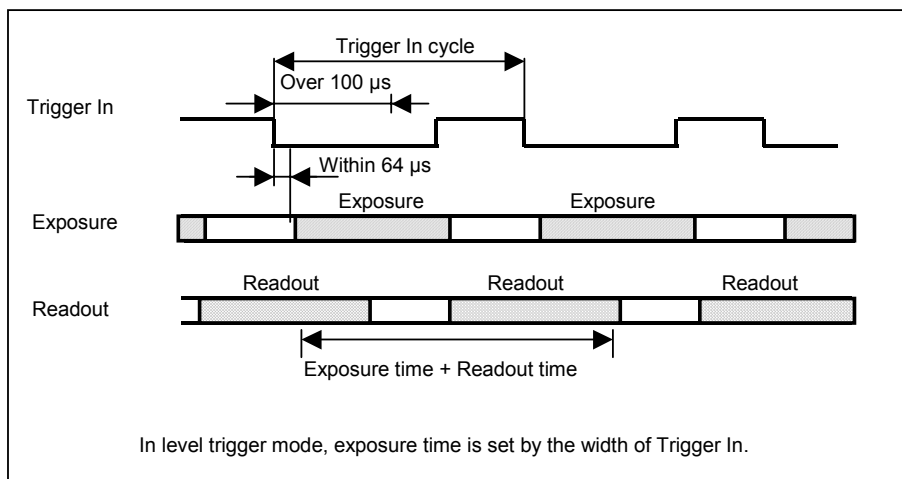
(2) Level trigger mode (pulse polarity is negative)**Trigger In cycle > Exposure time + Readout time****Trigger In cycle < Exposure time + Readout time (Cyclic trigger mode)**

(3) Synchronous Readout trigger mode (pulse polarity is negative)

Readout starts when Trigger In pulse is detected. The exposure time is defined as the time span of Trigger In pulses. The first pulse is ignored when this trigger mode is selected.

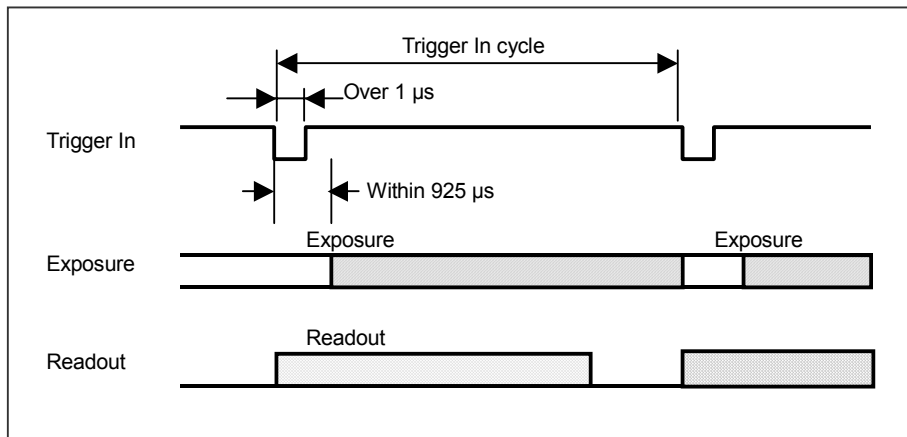

13-5-3 INTEG OUT TIMINGS

The integration-timing signal comes out. The signal level is C-MOS 3.3 V and it is available only in internal mode.

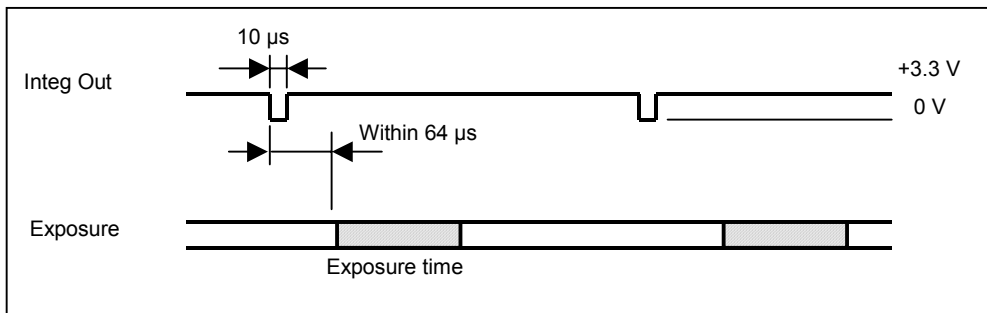

13-6 POWER SPECIFICATIONS

- Connector (D-SUB 15 pin)
- Product No. DA-15PF-T-N
- Maker JAE

[C9100 Series Pin Assignment]

No.	Name	Specs.
1	+12V (Camera)	Current 2.0 A (max.), Ripple peak to peak \pm 60 mV (max.)
2	N.C.	
3	N.C.	
4	N.C.	
5	+12V (Peltier)	Current 5.0 A (max.), Ripple peak to peak \pm 60 mV (max.)
6	N.C.	
7	GND (Peltier)	
8	N.C.	
9	SPARE	Connected to GND(Camera) via 0 ohm resister.
10	N.C.	
11	+12V (Peltier)	Current 5.0 A (max.), peak to peak \pm 60 mV (max.)
12	N.C.	
13	SPARE	Connected to GND(Camera) via 0 ohm resister.
14	GND (Camera)	
15	GND (Peltier)	

Note

- N.C. means non-connection.
- The 5-pin is connected to the 11-pin and the 7-pin is connected to the 15-pin inside camera.
- The current of +12 V (Peltier) is total of the 5-pin and the 11-pin.
- The two +12 V power supplies for camera and peltier are necessary for good performance of the camera.

14. DIMENSIONAL OUTLINE

14-1 CAMERA

(Unit: mm)

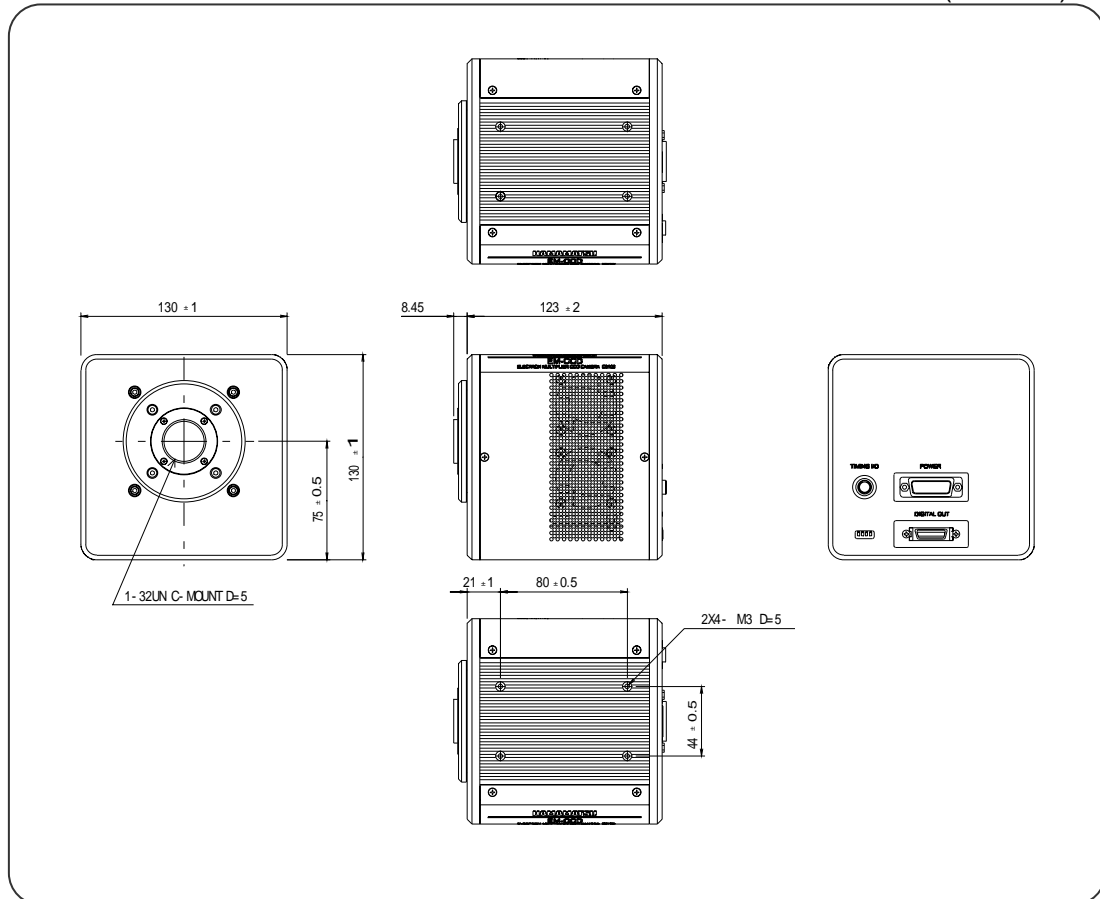

15. WARRANTY

Hamamatsu Photonics have fully inspected this system and checked that its performance conforms to specifications. In the unlikely event of breakdown or other malfunction, contact Hamamatsu subsidiary or local distributor.

- (1) Unless otherwise stated by Hamamatsu subsidiary or local distributor, this system is under warranty for 24 months from the delivery date.
 - Consumable parts, such as a fan, a mechanical shutter, and a fuse, are excepted.
 - Degradation with atomic rays, the radiation (X-rays, gamma rays, UV light, etc.) of CCD is excepted.
- (2) The warranty only covers defects in the materials and manufacturing of the system. You may be liable for repairs during the warranty period in the event of a natural disaster or if you handle the system contrary to the instructions in this manual, use it without due caution, or try to modify it.
- (3) We will repair the system or replace it, subject to availability, free of charge within the terms of the warranty.
- (4) HPK guarantees that the EM gain will not decrease by more than half of the maximum gain within 6 months.
- (5) We offer LIFETIME WARRANTY for the hermetically vacuum-shield head regarding vacuum leakage. However, following cases are exceptional to the LIFETIME WARRANTY.
 - Outgassing is under warranty for 12 months from the delivery date.
 - Peltier element deterioration is under warranty for 24 months from the delivery date.

REPAIRS

- (1) If you notice anything wrong with the camera, confirm whether or not it is malfunctioning by referring to the troubleshooting checklist in this instruction manual. You must first clarify the symptoms in order to avoid any misunderstanding or error.
- (2) If you have any trouble or are unclear about anything, contact Hamamatsu subsidiary or local distributor giving the product name, serial number and details of the problem. If Hamamatsu Photonics consider the problem to be a malfunction, we will decide whether dispatch an engineer or have the camera returned to us for repairs.

16. CONTACT INFORMATION

Japan

HAMAMATSU PHOTONICS K. K., Systems Division

812 Joko-cho, Higashi-ku, Hamamatsu City, 431-3196, Japan
Telephone (81) 53-431-0124, Fax: (81) 53-435-1574
E-mail: export@sys.hpk.co.jp

U.S.A. and Canada

Hamamatsu Corporation, Systems Division

360 Foothill Road, Bridgewater, N.J. 08807-0910, U.S.A.
Telephone: (1)908-231-1116, Fax: (1)908-231-0852
E-mail: usa@hamamatsu.com

Germany

Hamamatsu Photonics Deutschland GmbH

Arzbergerstr. 10, D-82211 Herrsching am Ammersee, Germany
Telephone: (49) 8152-375-0, Fax: (49) 8152-265-8
E-mail: info@hamamatsu.de

France

Hamamatsu Photonics France S.A.R.L.

19, Rue du Saule Trapu, Parc du Moulin de Massy, 91882 Massy Cedex,
France
Telephone: (33) 1 69 53 71 00, Fax: (33) 1 69 53 71 10
E-mail: infos@hamamatsu.fr

United Kingdom

Hamamatsu Photonics UK Limited

2 Howard Court, 10 Tewin Road, Welwyn Garden City Hertfordshire
AL7 1BW, United Kingdom
Telephone: (44) 1707-294888, Fax: (44) 1707-325777
E-mail: info@hamamatsu.co.uk

North Europe

Hamamatsu Photonics Norden AB

Smidesvagän 12, SE-171 41 Solna, Sweden
Telephone: (46) 8-509-031-00, Fax: (46)8-509-031-01
E-mail: info@hamamatsu.se

Italy

Hamamatsu Photonics Italia S.R.L.

Strada della Moia, 1/E 20020 Arese (Milano), Italy
Telephone: (39) 02-935 81 733, Fax: (39) 02-935 81 741
E-mail: info@hamamatsu.it

- *The contents of this manual are subject to change without notice.*
- *The unauthorized reproduction or distribution of parts or all of this manual is prohibited.*
- *If one of the following problems occurs, please contact Hamamatsu Photonics.
(See the CONTACT INFORMATION.) We will deal with the problem immediately.*
 - *Some contents of the manual are dubious, incorrect or missing.*
 - *Some pages of the manual are missing or in the wrong order.*
 - *The manual is missing or dirty.*