

Flat panel sensor C7942, C7943

Acquire digital X-ray image in real time and 170 & 176 mm diagonal size

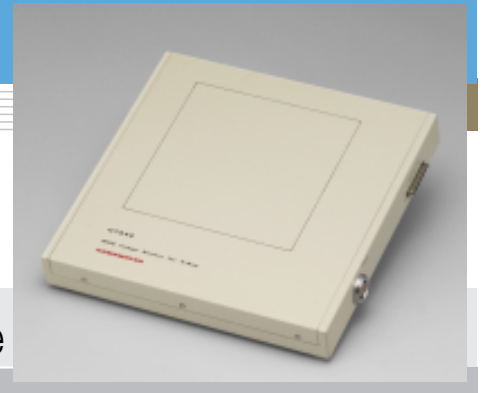

Hamamatsu C7942 and C7943 Flat Panel Sensors are digital X-ray image sensors newly developed as key devices for non-destructive inspection, biomedical imaging, X-ray microscopy and other real-time X-ray imaging applications requiring high resolution and high image quality. C7942 and C7943 consist of a sensor board and a control board, both assembled in a thin, flat and compact package. The sensor board contains a CsI scintillator plate, a two-dimensional photodiode array with FET switches and a signal processing IC chip. The photodiode array has a 2400 × 2400 (C7942) or 1248 × 1248 (C7943) pixel format with minimized blooming and is highly sensitive to bluish green light emitted from the CsI scintillator. Each row of pixels is addressed in sequence by the vertical shift register connected to the gate line.

Light emission occurs when X-rays are absorbed in the CsI scintillator. This light emission enters directly into the two-dimensional photodiode array where an electric charge is stored in each pixel according to the light intensity. This charge is then transferred to the corresponding data line by applying a control signal to the vertical shift register.

The sensor board also has 8 charge sensitive amplifier arrays each having 300 channel (C7942) or 156 channel (C7943) amplifiers with a horizontal shift register. These amplifiers with a total of 2400 channels (C7942) or 1248 channels (C7943) are connected to a CDS (Correlated Double Sampling) circuit that senses the charge on each video line and sends it as the analog video signal from each amplifier array. The control board converts the analog video signal into a 12-bit digital signal and outputs it to an external frame grabber from a 12-bit parallel port.

C7943 delivers a frame rate of 30 frames per second using 4 × 4 binning and is ideal for high frame rate applications. On the other hand, C7942 is ideal for applications requiring high resolution because of its 50 μm pixel size. Massive digital image data can easily be monitored on a display unit by using a frame grabber board and video memory installed in the PC. C7942 and C7943 will prove ideal tools for real-time X-ray imaging and processing where easy-to-use, high-resolution X-ray digital image sensors are needed.

Applications

- Non-destructive inspection
- Digital X-ray photography

Features

- C7942: 2400 × 2400 pixels
C7943: 1248 × 1248 pixels
- Digital output (12 bit)
- Dynamic picture image
C7942: 9 frame/s (4 × 4 binning)
C7943: 30 frame/s (4 × 4 binning)
- Low noise and wide dynamic range
- Compact package
- Easy use

■ Block diagram (C7942)

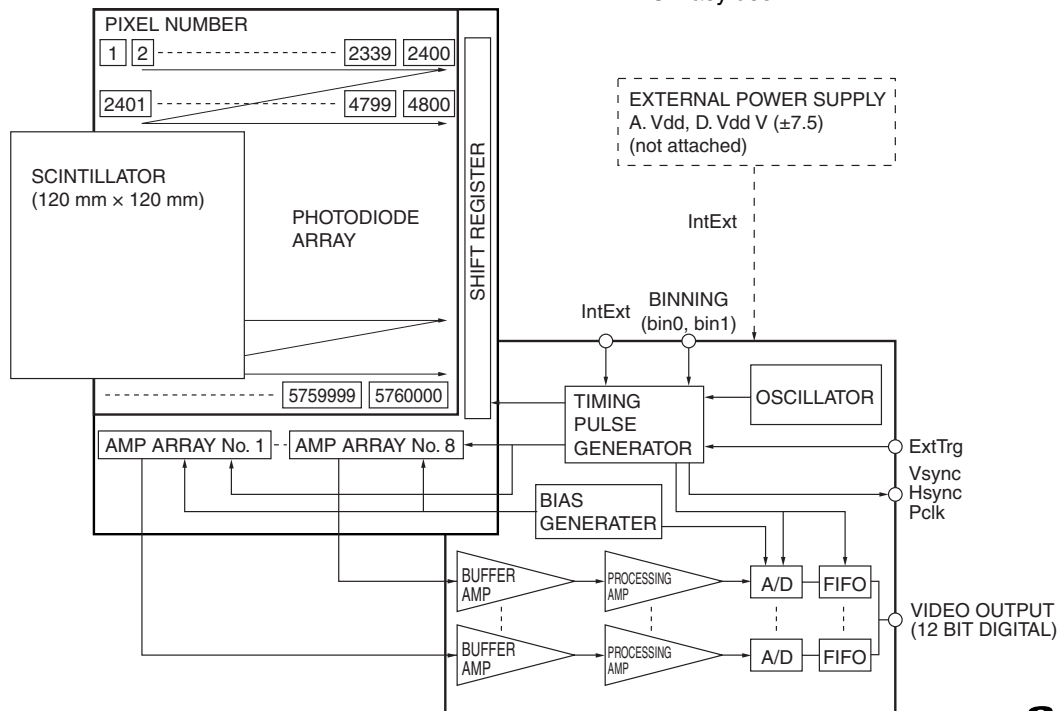

SOLID STATE DIVISION

■ Functional specification

Parameter	C7942	C7943
Readout	Charge amplifier array	
Feedback capacitance of each amplifier	0.15 pF	0.6 pF
Video output (Data1 - 12)	RS-422 (differential) 12 bit	
Output data rate	15.15 MHz	
Synchronous signal (Vsync, Hsync, Pclk)	RS-422 (differential)	
bin0, 1, ExtTrg, IntExt	TTL	

■ Absolute maximum ratings (Ta=25 °C)

Parameter	Symbol	Value	Unit
Supply voltage for digital circuitry (+5 V)	D.vdd	+6.0	V
Supply voltage for analog circuitry (+5 V)	A.vdd	+6.0	V
Supply voltage for analog circuitry (±7.5 V)	V(+/-7.5)	±12	V
Operating temperature (not condensed)	Topr	0 to +35	°C
Storage temperature (not condensed)	Tstg	0 to +50	°C

■ Specification (Unless otherwise noted, Typ. Ta=25 °C A.vdd= 5.0 V, D.vdd= 5.0 V, V (±7.5)= ±7.5 V)

Parameter	Symbol	C7942	C7943	Unit
Pixel size		50	100	µm
Active area		120 × 120	124.8 × 124.8	mm
Pixel number		5.76 (2400 × 2400)	1.56 (1248 × 1248)	M pixels
Number of active pixels (horizontal × vertical)	-	2240 × 2368	1216 × 1232	pixels
Frame speed (single operation)	Sf (int)	2	7	frame/s
Frame speed (2 × 2 binning)		4	15	frame/s
Frame speed (4 × 4 binning)		9	30	frame/s
Frame speed external (single operation)	Sf (ext)	Sf (int) to 0.1	Sf (int) to 0.1	frame/s
Noise (rms.)	N (rms.)	1100	2300	electrons
Saturation charge	Csat	2.2	10	M electrons
Resolution	Reso	8	5	line pairs/mm
Dynamic range		2000	4300	-
Defect line *	-	20 Max.	10 Max.	lines
Scintillator	-		CsI	-

* Without a couple of adjacent defect line.

■ Timing chart

To acquire images through an image grabber board, parameters that match the following timing chart should be described in the software program or parameter file.

Internal mode

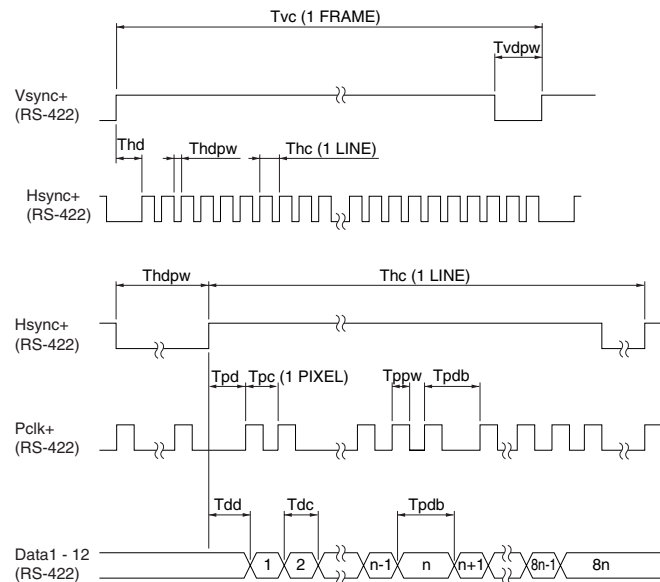

In case of C7942, the number of n is 300.
In case of C7943 the number of n is 156.

KACCC0138EB

External mode

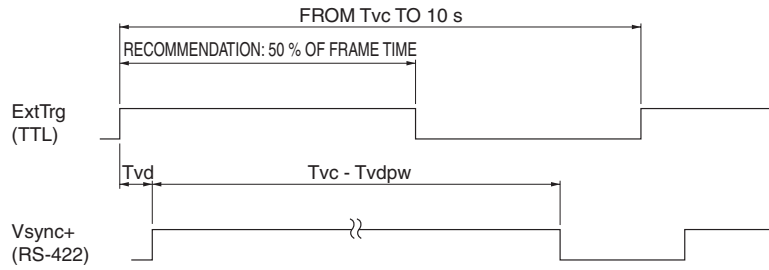

Hsync+, Pclk and Data 1-12 are the same as internal trigger mode.

KACCC0139EB

C7942

1 × 1 mode (Typ.)

Parameter		Symbol	Value	Unit
Vsync	Delay time (only external trigger mode)	Tvd	390	μs
	Cycle time	Tvc	470	ms
	Dummy pulse width	Tvdpw	770	μs
Hsync	Delay time	Thd	1.4	μs
	Cycle time	Thc	190	μs
	Dummy pulse width	Thdpw	35	μs
Pclk	Delay time	Tpd	65	ns
	Cycle time	Tpc	66	ns
	Pulse width	Tppw	33	ns
	Delay time between each block	Tpdb	200	ns
Data1-12	Delay time	Tdd	34	ns
	Cycle time	Tdc	66	ns

2 × 2 mode (Typ.)

Parameter		Symbol	Value	Unit
Vsync	Delay time (only external trigger mode)	Tvd	390	μs
	Cycle time	Tvc	230	ms
	Dummy pulse width	Tvdpw	770	μs
Hsync	Delay time	Thd	1.4	μs
	Cycle time	Thc	190	μs
	Dummy pulse width	Thdpw	110	μs
Pclk	Delay time	Tpd	65	ns
	Cycle time	Tpc	66	ns
	Pulse width	Tppw	33	ns
	Delay time between each block	Tpdb	200	ns
Data1-12	Delay time	Tdd	34	ns
	Cycle time	Tdc	66	ns

4 × 4 mode (Typ.)

Parameter		Symbol	Value	Unit
Vsync	Delay time (only external trigger mode)	Tvd	390	μs
	Cycle time	Tvc	117	ms
	Dummy pulse width	Tvdpw	770	μs
Hsync	Delay time	Thd	1.4	μs
	Cycle time	Thc	190	μs
	Dummy pulse width	Thdpw	150	μs
Pclk	Delay time	Tpd	65	ns
	Cycle time	Tpc	66	ns
	Pulse width	Tppw	33	ns
	Delay time between each block	Tpdb	200	ns
Data1-12	Delay time	Tdd	34	ns
	Cycle time	Tdc	66	ns

Note) The numbers of significant figures is two. (except Tvc)

C7943

1 × 1 mode (Typ.)

	Parameter	Symbol	Value	Unit
Vsync	Delay time (only external trigger mode)	Tvd	210	μs
	Cycle time	Tvc	130	ms
	Dummy pulse width	Tvdpw	420	μs
Hsync	Delay time	Thd	1.8	μs
	Cycle time	Thc	110	μs
	Dummy pulse width	Thdpw	22	μs
Pclk	Delay time	Tpd	65	ns
	Cycle time	Tpc	66	ns
	Pulse width	Tppw	33	ns
	Delay time between each block	Tpdb	200	ns
Data1-12	Delay time	Tdd	33	ns
	Cycle time	Tdc	66	ns

2 × 2 mode (Typ.)

	Parameter	Symbol	Value	Unit
Vsync	Delay time (only external trigger mode)	Tvd	210	μs
	Cycle time	Tvc	66	ms
	Dummy pulse width	Tvdpw	420	μs
Hsync	Delay time	Thd	1.8	μs
	Cycle time	Thc	110	μs
	Dummy pulse width	Thdpw	63	μs
Pclk	Delay time	Tpd	65	ns
	Cycle time	Tpc	66	ns
	Pulse width	Tppw	33	ns
	Delay time between each block	Tpdb	200	ns
Data1-12	Delay time	Tdd	33	ns
	Cycle time	Tdc	66	ns

4 × 4 mode (Typ.)

	Parameter	Symbol	Value	Unit
Vsync	Delay time (only external trigger mode)	Tvd	210	μs
	Cycle time	Tvc	33	ms
	Dummy pulse width	Tvdpw	420	μs
Hsync	Delay time	Thd	1.8	μs
	Cycle time	Thc	110	μs
	Dummy pulse width	Thdpw	84	μs
Pclk	Delay time	Tpd	65	ns
	Cycle time	Tpc	66	ns
	Pulse width	Tppw	33	ns
	Delay time between each block	Tpdb	200	ns
Data1-12	Delay time	Tdd	33	ns
	Cycle time	Tdc	66	ns

Note) The numbers of significant figures is two.

■ System requirements

To operate C7942 and C7943 Flat Panel Sensors at full performance, the following system and peripherals are required.

PC: IBM compatible PC running on Windows 98 or later operating system

Digital frame grabber card: Monochrome 16 bits or more, pixel clock 16 MHz or more, RS-422 interface synchronous signal (See the frame grabber manual.)

The National Instruments IMAQ PCI-1424 (NI parts No. 777662-01) frame grabber with optional memory 64 MB (NI parts No. 920130-64) has been verified to successfully acquire 12-bit digital images from both C7942 and C7943. The IMAQ PCI-1422 (NI parts No. 777959-01) also acquires satisfactory images from C7943. You can utilize the demonstration software that comes with the frame grabber as a simple viewer, to acquire and save an image. To do so, refer to the frame grabber user's guide for how to use the camera information file for the demonstration software.

Power source: A. Vdd = +5.0 ± 0.1 V (700 mA), D. Vdd = +5.0 ± 0.1 V (1000 mA), V (±7.5) = ±7.5 ± 0.5 V (±100 mA). Use of a series power supply is recommended. (Avoid using a switching power supply.) A power cable (terminated with an FGG.2B.307.CLAD92Z plug at one end and open at the other end; 2 m; see Table 2.) comes supplied with C7942 and C7943. An optional 36-pin cable for interface with the 36-pin receptacle (see Table 1) on C7942 and C7943 is also available for synchronous signal input, video output and external control.

Table 1 Pin assignment of 36-pin receptacle

Pin No.	Signal	Pin No.	Signal
1	Data1+ (MSB)	19	Data1- (MSB)
2	Data2+	20	Data2-
3	Data3+	21	Data3-
4	Data4+	22	Data4-
5	Data5+	23	Data5-
6	Data6+	24	Data6-
7	Data7+	25	Data7-
8	Data8+	26	Data8-
9	Data9+	27	Data9-
10	Data10+	28	Data10-
11	Data11+	29	Data11-
12	Data12+(LSB)	30	Data12- (LSB)
13	bin0 (TTL)	31	Gnd
14	bin1 (TTL)	32	Gnd
15	ExtTrg (TTL)	33	IntExt (TTL)
16	Vsync+	34	Vsync-
17	Hsync+	35	Hsync-
18	Pclk+	36	Pclk-

Unless otherwise noted, signal level is RS-422.

36-pin receptacle: TX20A-36R-D2GF1-A1L made by JAE (Japan Aviation Electronics Industry limited)

36-pin mating plug: TX20A-36PH1-D2P1-D1 made by JAE (Japan Aviation Electronics Industry limited)

Table 2 Power pin assignment and cable color

Pin No.	Color	Signal
1	Brown	+7.5 V
2	Red	Analog GND
3	Orange	-7.5 V
4	Yellow	Analog GND
5	Green	Analog +5 V
6	Blue	Digital GND
7	Purple	Digital +5 V
Shield	-	Analog GND

7-pin power plug: FGG.2B.307.CLAD92Z made by LEMO S. A. (<http://www.lemo.ch>)

7-pin power receptacle: ECG.2B.307.CLV made by LEMO S. A.

■ Connection

Install the frame grabber board into the PC by following the manufacturer's instructions. When a general-purpose frame grabber board is used, binning or trigger operation for bin0, bin1, IntExt and ExtTrig can be controlled with its digital I/O control.

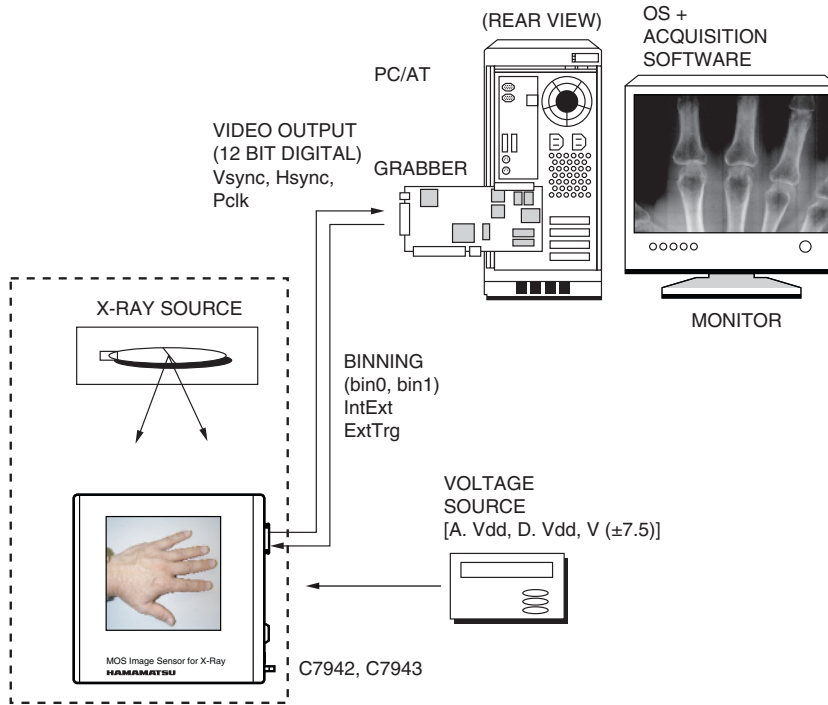

KACCC0140EA

■ Dimensional outline (unit: mm)

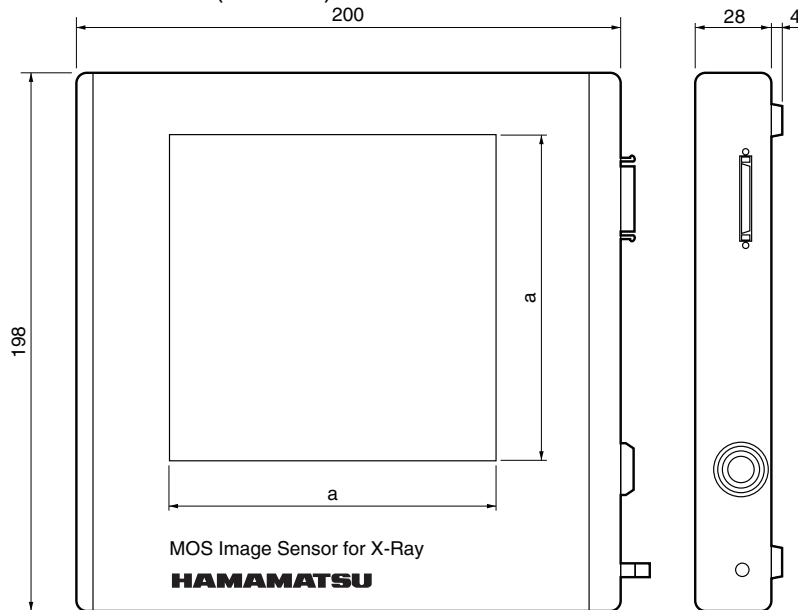

Top cover is made of aluminum 1.0 mm thick.

	C7942	C7943
a	120	124.8

KACCA0095EA

■ Precautions

Do not subject the Flat Panel Sensors to strong vibration or shock. (Strong shock such as drop impacts may cause permanent damage to these sensors.)

Users must take responsibility for implementing X-ray shielding safety measures to avoid the risk of X-ray exposure.

Optional 36-pin cables

Two types of 36-pin cables are provided as options for connecting to the frame grabber.

Type A (A8406-01): General-purpose interface cable for digital frame grabber.

Type B (A8406-02): Interface cable for IMAQ PCI-1424 grabber board.

Type	Cable type No.	Cable end	Cable end
A	A8406-01	TX20A-36PH1-D2P1-D1 *1	open
B	A8406-02		PCS-XE100MA *2

*1: Made by JAE (Japan Aviation Electronics Industry, Limited)

*2: Made by Honda Tsushin Kogyo Co. Ltd.

A8406-01 cable for general frame grabber

A8406-01 is a cable that connects the Flat Panel Sensor (C7942 or C7943) to a general frame grabber. One end of this cable has a 36-pin plug mating with the C7942 or C7943 digital output receptacle, but the other end is left open. Connect the open end to a plug that mates with the frame grabber to be used. Cable color coding and specifications are shown in the table below.

■ Cable color coding and specifications

Pin No.	Signal	Cable color	Marking color	Pin No.	Signal	Cable color	Marking color
1	Data1+ (MSB)	blue	-	19	Data1- (MSB)	orange	-
2	Data2+	green	-	20	Data2-	brown	-
3	Data3+	gray	-	21	Data3-	red	-
4	Data4+	black	-	22	Data4-	yellow	-
5	Data5+	pink	-	23	Data5-	purple	-
6	Data6+	white	-	24	Data6-	blue	red
7	Data7+	orange	white	25	Data7-	green	white
8	Data8+	brown	white	26	Data8-	gray	white
9	Data9+	red	white	27	Data9-	black	white
10	Data10+	yellow	black	28	Data10-	pink	black
11	Data11+	purple	white	29	Data11-	white	blue
12	Data12+ (LSB)	blue	red	30	Data12- (LSB)	orange	white
13	bin0 (TTL)	green	white	31	Gnd	brown	white
14	bin1 (TTL)	gray	white	32	Gnd	red	white
15	ExtTrg (TTL)	black	white	33	IntExt (TTL)	yellow	black
16	Vsync+	pink	black	34	Vsync-	purple	white
17	Hsync+	white	blue	35	Hsync-	blue	black
18	Pclk+	orange	black	36	Pclk-	green	black

■ Dimensional outline (unit: mm)

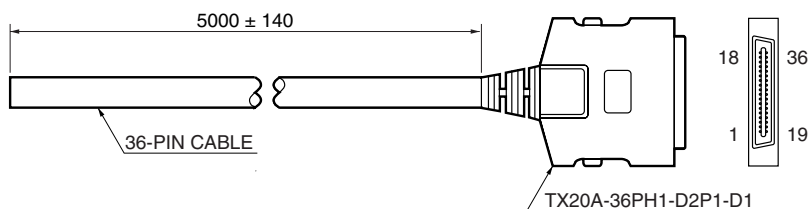

KACCA0096EA

A8406-02 cable for IMAQ PCI-1424 frame grabber

A8406-02 cable is designed to connect the Flat Panel Sensor (C7942 or C7943) to the National Instrument IMAQ PCI-1424 (NI parts No. 777662-01) digital frame grabber board. Both ends of this cable have connectors. One end is a 36-pin plug mating with the C7942 or C7943 digital output receptacle, while the other end is a 100-pin plug for the IMAQ PCI-1424.

Pin connection for A8406-02

TX20A-36PH1-D2P1-D1 Pin No.	Signal	PCS-XE100MA Pin No.	TX20A-36PH1-D2P1-D1 Pin No.	Signal	PCS-XE100MA Pin No.
1	Data1+ (MSB)	23	19	Data1- (MSB)	24
2	Data2+	21	20	Data2-	22
3	Data3+	19	21	Data3-	20
4	Data4+	17	22	Data4-	18
5	Data5+	15	23	Data5-	16
6	Data6+	13	24	Data6-	14
7	Data7+	11	25	Data7-	12
8	Data8+	9	26	Data8-	10
9	Data9+	7	27	Data9-	8
10	Data10+	5	28	Data10-	6
11	Data11+	3	29	Data11-	4
12	Data12+ (LSB)	1	30	Data12- (LSB)	2
13	bin0 (TTL)	33	31	Gnd	99
14	bin1 (TTL)	35	32	Gnd	100
15	ExtTrg (TTL)	37	33	IntExt (TTL)	39
16	Vsync+	41	34	Vsync-	42
17	Hsync+	43	35	Hsync-	44
18	Pclk+	49	36	Pclk-	50

Dimensional outline (unit: mm)

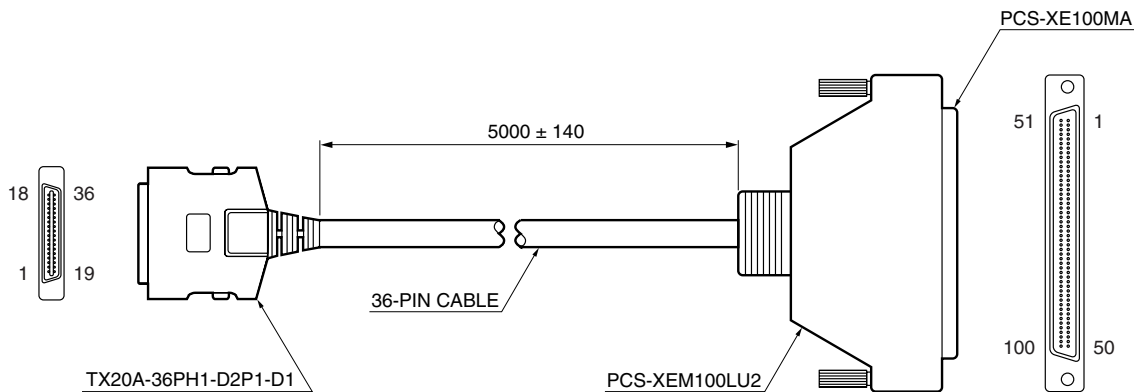

KACCA0097EA

Note) This product was not designed and manufactured for use as a medical X-ray device. System manufacturers must take responsibility for obtaining MHW or FDA approval when incorporating this product into a medical diagnostics system.

HAMAMATSU

Information furnished by HAMAMATSU is believed to be reliable. However, no responsibility is assumed for possible inaccuracies or omissions. Specifications are subject to change without notice. No patent rights are granted to any of the circuits described herein. ©2002 Hamamatsu Photonics K.K.

HAMAMATSU PHOTONICS K.K., Solid State Division

1126-1 Ichino-cho, Hamamatsu City, 435-8558 Japan, Telephone: (81) 053-434-3311, Fax: (81) 053-434-5184, <http://www.hamamatsu.com>

U.S.A.: Hamamatsu Corporation: 360 Foothill Road, P.O.Box 6910, Bridgewater, N.J. 08807-0910, U.S.A., Telephone: (1) 908-231-0960, Fax: (1) 908-231-1218

Germany: Hamamatsu Photonics Deutschland GmbH: Arzbergerstr. 10, D-82211 Herrsching am Ammersee, Germany, Telephone: (49) 08152-3750, Fax: (49) 08152-2658

France: Hamamatsu Photonics France S.A.R.L.: 8, Rue du Saule Trapu, Parc du Moulin de Massy, 91882 Massy Cedex, France, Telephone: 33-(1) 69 53 71 00, Fax: 33-(1) 69 53 71 10

United Kingdom: Hamamatsu Photonics UK Limited: 2 Howard Court, 10 Tewin Road, Welwyn Garden City, Hertfordshire AL7 1BW, United Kingdom, Telephone: (44) 1707-294888, Fax: (44) 1707-325777

North Europe: Hamamatsu Photonics Norden AB: Smidesvägen 12, SE-171 41 Solna, Sweden, Telephone: (46) 8-509-031-00, Fax: (46) 8-509-031-01

Italy: Hamamatsu Photonics Italia S.R.L.: Strada della Moia, 1/E, 20020 Arese, (Milano), Italy, Telephone: (39) 02-935-81-733, Fax: (39) 02-935-81-741