



The C6086-30 camera series is a newly developed, highly sensitive, X-ray image intensified CCD camera. This camera is specifically design for micro focus X-ray source applications, which typically require greater sensitive than standard X-ray sensitive CCD cameras.

By coupling a proximity focused image intensifier with tapered fiber optic plate (FOP) the C6086-30 series realizes excellent sensitivity while maintain high resolution and image quality.

FEATURES

- **High spatial resolution**
43 μm (typical value, not guaranteed)
- **Effective X-ray tube voltage range**
10 to 100kVp
- **Proximity focused II**
Low image distortion.
- **FOP coupled to the CCD**
High coupling efficiency
- **Large effective area**
14.3 mm x 10.7 mm (EIA)
14.0 mm x 10.5 mm (CCIR)
- **P43 (GdO₂S:Tb) scintillator**
- **High sensitivity**

SPECIFICATIONS

• Spatial resolution of camera head

43 μ m (typical value, not guaranteed)

• X-ray scintillator of camera head

Material of scintillator	P43 (Gd ₂ S:Tb)
Effective X-ray tube voltage range	10 to 100kVp
Effective field of view (mm ²)	14.3(H) × 10.7 (V) (EIA) 14.0(H) × 10.5 (V) (CCIR)

• Image intensifier of camera head

Structure	Proximity focused
-----------	-------------------

• CCD detector of camera head

Type. No.	C6086-31	C6086-32
Imaging device	Interline-type CCD	
Video system	EIA	CCIR
Effective no. of pixels	768 (H) × 493 (V)	756 (H) × 581 (V)
H. frequency	15.734 kHz	15.625 kHz
V. frequency	59.94 Hz	50 Hz
Scanning type	2:1 interlaced	
Video output	1.0Vp-p 75 Ω terminated	

• Camera controller

A/D converter	10-bit
Memory size	768 (H) × 493 (V)(NTSC) 756 (H) × 581 (V)(CCIR)
Frame memory	16-bit memory × 2 planes
Digital interface	SCSI II (optional)
Input signal	Composite 1.0Vp-p/75 Ω
Image processing functions	Gain/Offset, On-chip integration, Image accumulation, Recursive average, Zoom, Background subtraction, Edge enhancement mask (selectable)
Line voltage	AC 100V, 117V, 220V, 240V \pm 10% 50/60Hz
Operating temperature	0 to 40 °C
Operating humidity	Less than 70%

• I.I. controller

Functions	Gain control, Overload protection
Line voltage	100 to 240VAC, 50/60 Hz
Operating temperature	0 to 40 °C
Operating humidity	Less than 70%

DIMENSIONAL OUTLINE (unit : mm)

• Camera head

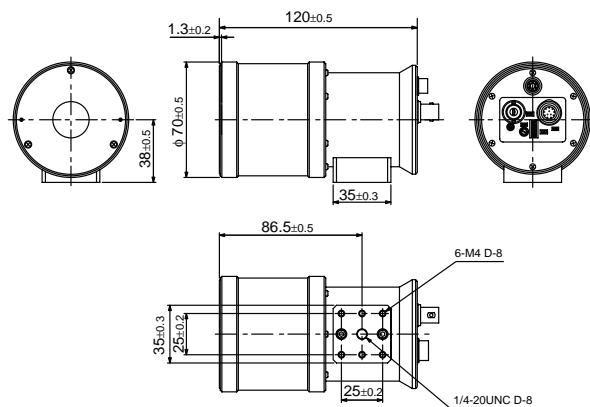

(Weight : approx. 0.8kg)

• Camera controller

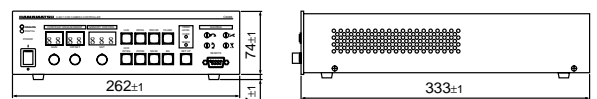

(Weight : approx. 4.5kg)

• I.I. controller

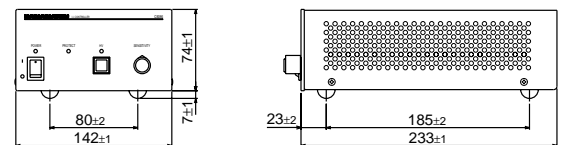

(Weight : approx. 1.3kg)



★ Product and software package names noted in this documentation are trademarks or registered trademarks of their respective manufacturers.

• Subject to local technical requirements and regulations, availability of products included in this promotional material may vary. Please consult with our sales office.

• Information furnished by HAMAMATSU is believed to be reliable. However, no responsibility is assumed for possible inaccuracies or omissions.

Specifications and external appearance are subject to change without notice.

© 2001 Hamamatsu Photonics K.K.

HAMAMATSU

Homepage Address <http://www.hamamatsu.com>

HAMAMATSU PHOTONICS K.K., Systems Division
812 Joko-cho, Hamamatsu City, 431-3196, Japan, Telephone: (81)53-431-0124, Fax: (81)53-435-1574, E-mail: export@sys.hpk.co.jp

U.S.A. and Canada: Hamamatsu Photonic Systems: 360 Foothill Road, Bridgewater, N.J. 08807-0910, U.S.A., Telephone: (1)908-231-1116, Fax: (1)908-231-0852, E-mail: usa@hamamatsu.com

Germany: Hamamatsu Photonics Deutschland GmbH: Arzbergerstr. 10, D-82211 Herrsching am Ammersee, Germany, Telephone: (49)8152-375-0, Fax: (49)8152-2658, E-mail: info@hamamatsu.de

France: Hamamatsu Photonics France S.A.R.L.: 8, Rue du Saule Trapu, Parc du Moulin de Massy, 91882 Massy Cedex, France, Telephone: (33)1 69 53 71 00, Fax: (33)1 69 53 71 10, E-mail: infos@hamamatsu.fr

United Kingdom: Hamamatsu Photonics UK Limited: 2 Howard Court, 10 Twin Road, Welwyn Garden City, Hertfordshire, AL7 1BW, U.K., Telephone: (44) 1707-294888, Fax: (44) 1707-325777, E-mail: info@hamamatsu.co.uk

North Europe: Hamamatsu Photonics Norden AB: Smidsvågen 12, SE-171-41 Solna, Sweden, Telephone: (46)8-509-031-00, Fax: (46)8-509-031-01, E-mail: info@hamamatsu.se

Italy: Hamamatsu Photonics Italia S.R.L.: Strada della Moiss, 1/E 20020 Arese (Milano), Italy, Telephone: (39)02-935 81 733, Fax: (39)02-935 81 741, E-mail: info@hamamatsu.it

Cat. No. SICS1073E02
SEP/2001 HPK
Created in Japan (PDF)

This datasheet has been download from:

www.datasheetcatalog.com

Datasheets for electronics components.