

# Streak Camera C2830



Streak cameras are high-speed light detectors which enable direct measurement of light phenomena with unsurpassed temporal resolution. They can simultaneously measure time, position (or wavelength) and light intensity, and process the data in real-time using a dedicated read-out system.

The Streak Camera C2830 can be equipped with either of two plug-ins: a fast-speed (for better than 10 ps resolution) or a slow-speed (for better than 100 ps resolution) sweep unit. In addition, C2830 has a 100 ns high-speed electronic shutter which eliminates unnecessary incident light during the nonsweep period and makes it possible to do sampling measurements on continuous phenomena.

## FEATURES

- Designed for single sweep operations
- Covers a wide time range from 500 ps to 1 ms (using both fast and slow sweep plug-in units)
- Temporal resolution
  - Fast sweep unit: Better than 10 ps
  - Slow sweep unit: Better than 100 ps
- Simultaneous measuring time, position (or wavelength) and light intensity
- High sensitivity (single photoelectron detectability)
- High-speed gate function

# HAMAMATSU

# Plug-in Sweep Units Available: Fast Sweep Unit Slow Sweep Unit

## SYSTEM CONFIGURATION

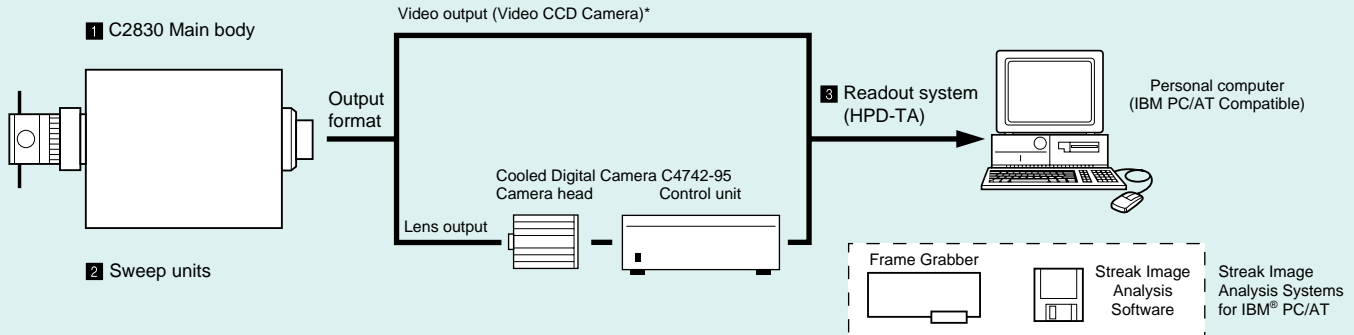

★ Built in main body.

## OPERATING PRINCIPLE

The streak camera converts incident light into electrons and performs a high-speed sweep (deflecting electrons from top to bottom), enabling detection of the time variation of the incident light intensity by converting these into different positions on the screen. The figure below shows the operating principle of the streak tube, which forms the heart of the streak camera.

The light pulse to be measured is focused onto the photocathode of the streak tube through the slit, where the photons are converted into a number of electrons proportional to the intensity of the incident light. These electrons are accelerated and conducted towards the phosphor screen, and a high-speed voltage which is synchronized to the incident light is applied. The electrons are swept at high speed from top to bottom and are then multiplied in the MCP (micro-channel plate), after which they are bombarded against the phosphor screen of the streak tube and converted to an optical image.

The optical image which appears on the phosphor screen is called a streak image, and shows the intensity distribution of the incident light, by which the positions of the electrons can be

determined in the perpendicular direction over the passage of time. Using this method, the temporal intensity distribution of the light being measured can be displayed as the spatial intensity distribution on the phosphor screen.

## APPLICATIONS

- Research involving free electron lasers and various other types of pulsed lasers
- Plasma light emission, radiation, laser ablation, combustion and explosions
- Fluorescence lifetime measurement, transient absorption measurement, time-resolved Raman spectroscopy
- Lidar, Thomson scattering, laser distance measurement

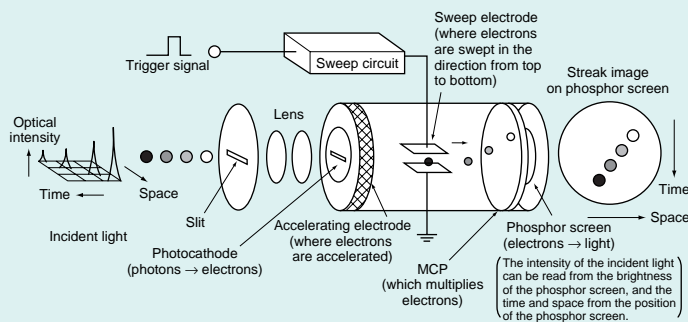

[Operating Principle of the Streak Tube]

# (temporal resolution: better than 10 ps) (temporal resolution: better than 100 ps)

## SPECIFICATIONS

### 1 C2830 Main Body

#### ● Input Optics

Slit length: 0 to 8.0 mm  
 Slit width: 0 to 5 mm (5  $\mu$ m accuracy)  
 Image magnification: 1:1  
 Spectral transmission: 200 nm to 850 nm  
 Effective aperture ratio: F/5

#### ● Streak Tube N2803

Window material: UV glass  
 Photocathode: Multi-alkali (S-20)  
 Spectral response: 200 nm to 850 nm  
 Useful photocathode: 8.0 mm  $\times$  1.5 mm  
 Image magnification: 1 : 1.5  
 Light gain: more than  $3 \times 10^3$   
 Phosphor screen: P-43  
 Useful screen area: 12 mm (space)  $\times$  15 mm (streak length) dia.

Spectral Response Characteristic of the Streak Tube

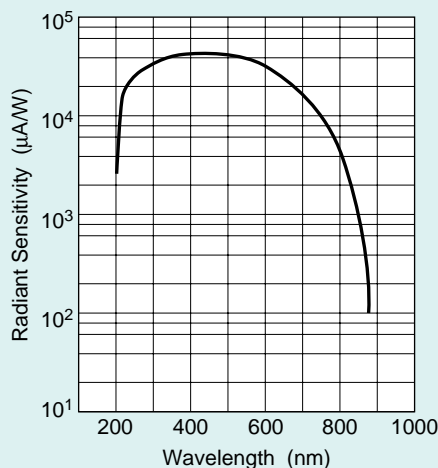

#### ● Gate

Gating Method	Gate Extinction Ratio	Gate Time
MCP	1 : $10^3$ min.	100 ns to continuous
MCP + photocathode	1 : $10^6$ min.	100 ns to continuous

#### ● Output Formats

- Lens output for Cooled Digital Camera C4742-95
  - Magnification ..... 1 : 0.7
  - Effective F number ..... F/2.0
  - F-mount
- Video output
  - Signal format ..... CCIR or RS-170
  - Coupling method ..... Fiber optics
  - Resolution ..... 768  $\times$  493 or 756  $\times$  581 pixels

● **Line Voltage:** 110/117/220/240 V AC, 50/60 Hz

● **Power Consumption:** Approx. 80 VA

### 2 Sweep Units

#### ● Fast Sweep Unit M2547

Temporal resolution: better than 10 ps  
 Sweep time/full screen: 0.5, 1, 2, 5, 10 ns/15 mm  
 Trigger jitter: less than  $\pm 20$  ps  
 Trigger delay: about 20 ns at the fastest range only  
 Streak trigger signal input: +5 to +40 Vp-p/50  $\Omega$   
 Monitor signal output: +3 Vp-p/50  $\Omega$   
 Reset signal input: reset at 0 V  
 Gate trigger signal input: +2 to +10 Vp-p/50  $\Omega$   
 Sweep repetition rate: 1 KHz max.  
 Dynamic range: >100 at the fastest range

#### ● Slow Sweep Unit M2548

Temporal resolution: better than 100 ps  
 Sweep time/full screen: 10 ns to 1 ms/15 mm, 16 ranges  
 Trigger jitter: less than  $\pm 50$  ps  
 Trigger delay: about 45 ns at the fastest range only  
 Streak trigger signal input: +5 to +40 Vp-p/50  $\Omega$   
 Monitor signal output: +3 Vp-p/50  $\Omega$   
 Reset signal input: reset at 0 V  
 Gate trigger signal input: +2 to +10 Vp-p/50  $\Omega$   
 Sweep repetition rate: 10 KHz max.  
 Dynamic range: >200 at the fastest range

### 3 Readout System\*

#### ● HPD-TA

The HPD-TA (Temporal Analyzer) is a high-performance digital data acquisition and control system specifically designed to read out images from the Hamamatsu streak camera's phosphor screen. It enables precise, quantitative acquisition and pre-analysis of two dimensional streak data that includes photon counting plus a full range of data correction and calibration possibilities. It possible to select the best camera for a given streak configuration and application. The camera is connected to an IBM-compatible PC/AT via a frame grabber board that can support real-time data transfer.

The entire system is controlled through a powerful but user-friendly software application that runs on a Microsoft Windows platform.

\* A read out system based on the Macintosh<sup>®</sup> computer is also available. Please consult with our sales office for more details.

# Streak Camera C2830

## ● C4547-01 Streak Trigger Unit

This creates gate trigger signals and streak trigger signals from an external trigger signal, and supplies them to the single sweep unit.

It is equipped with a divider function, enabling external trigger signals with a higher frequency than that of the sweep repetition frequency to be used.

Frequency band	10 MHz to 200 MHz
Input level	0 to 15 dBm/50 Ω
Output signal level	3 Vp-p/50 Ω
Output frequency	1 Hz to 100 kHz (variable)

## ● C1097-01 Delay Unit

This unit can be used to align the operation timing of the streak camera with the target phenomenon.

\* A GP-IB interface is available as an option. (C1097-04)

Variable delay range	0 to 31.96 ps
Delay setting range	30, 60, 120, 250, 500 ps, 1, 2, 4, 8, 16 ns
Minimum delay time	Approx. 12 ns
Maximum input voltage	30 V
Power supply	AC 85 to 250 V
External dimensions/weight	215 (W) × 350 (D) × 102 (H) mm/3.4 kg

## ● C1083-01 PIN Photodiode

This device converts the incident light pulse into the streak trigger signal for the single sweep unit (M2547 and M2548). A slow repetition pulse laser is used as the applicable light source.

Spectral response	400 to 1100 nm
Rise time	0.8 ns
Dimensions/weight	Head: 100 (W) × 160 to 235 (H) × 50 (D) mm/400 g Power supply unit: 100 (W) × 83(H) × 100 (D) mm/400 g
Power supply	+45 V (battery)

## ▀ DIMENSIONAL OUTLINE (Unit: mm)

### ● Main Unit (approx. 13.5 kg)

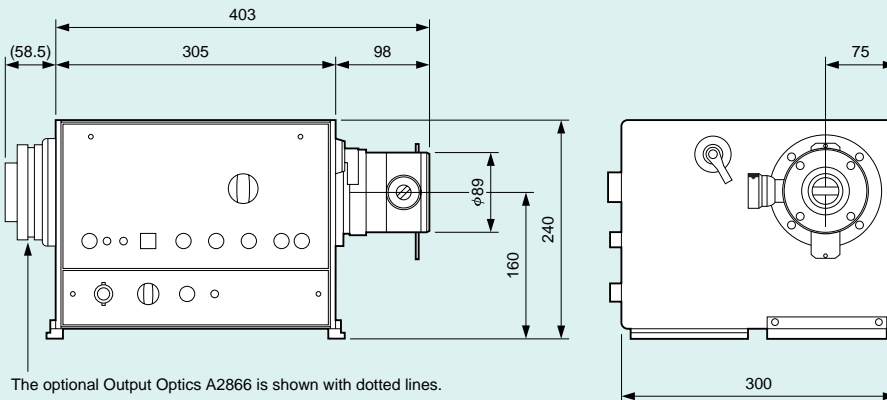

### ● Power Supply Unit (approx. 6 kg)

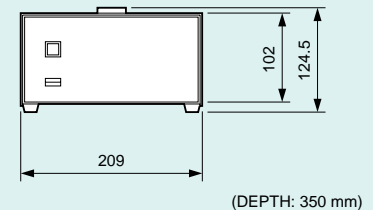

- ★ IBM is a registered trademark of IBM Co.
- ★ Macintosh is a registered trademark of Apple Computer, Inc.
- ★ Product and software package names noted in this documentation are trademarks or registered trademarks of their respective manufacturers.

- Subject to local technical requirements and regulations, availability of products included in this promotional material may vary. Please consult with our sales office.
- Information furnished by HAMAMATSU is believed to be reliable. However, no responsibility is assumed for possible inaccuracies or omissions. Specifications and external appearance are subject to change without notice.

© 1999 Hamamatsu Photonics K.K.



# HAMAMATSU

Homepage Address <http://www.hamamatsu.com>

HAMAMATSU PHOTONICS K.K., Systems Division  
812 Joko-cho, Hamamatsu City, 431-3196, Japan, Telephone: (81)53-431-0124, Fax: (81)53-435-1574, E-mail:export@sys.hpk.co.jp

U.S.A. and Canada: Hamamatsu Photonic Systems: 360 Foothill Road, Bridgewater, N.J. 08807-0910, U.S.A., Telephone: (1)908-231-1116, Fax: (1)908-231-0852, E-mail:usa@hamamatsu.com  
Germany: Hamamatsu Photonics Deutschland GmbH: Arzbergerstr. 10, D-82211 Herrsching am Ammersee, Germany, Telephone: (49)8152-375-0, Fax: (49)8152-2658, E-mail:info@hamamatsu.de  
France: Hamamatsu Photonics France S.A.R.L.: 8, Rue du Saule Trapu, Parc du Moulin de Massy, 91882 Massy Cedex, France, Telephone: (33)1 69 53 71 00, Fax: (33)1 69 53 71 10, E-mail:france@hamamatsu.com  
United Kingdom: Hamamatsu Photonics UK Limited: Lough Point, 2 Gladbeck Way, Windmill Hill, Enfield, Middlesex EN2 7JA, United Kingdom, Telephone: (44)208-367-3560, Fax: (44)208-367-6384, E-mail:info@hamamatsu.co.uk  
North Europe: Hamamatsu Photonics Norden AB: Smidesvägen 12, SE-171-41 Solna, Sweden, Telephone: (46)8-509-031-00, Fax: (46)8-509-031-01, E-mail:system@hamamatsu.se  
Italy: Hamamatsu Photonics Italia S.R.L.: Strada della Moia, 1/E 20020 Arese (Milano), Italy, Telephone: (39)02-935 81 733, Fax: (39)02-935 81 741, E-mail:info@hamamatsu.it

Cat. No SSCS1036E03  
AUG/99 CR  
Created in Japan (PDF)

This datasheet has been download from:

[www.datasheetcatalog.com](http://www.datasheetcatalog.com)

Datasheets for electronics components.