

NEW

IMAGE SENSOR

Flat panel sensor C10322D

High sensitivity, high-speed frame rate, high resolution

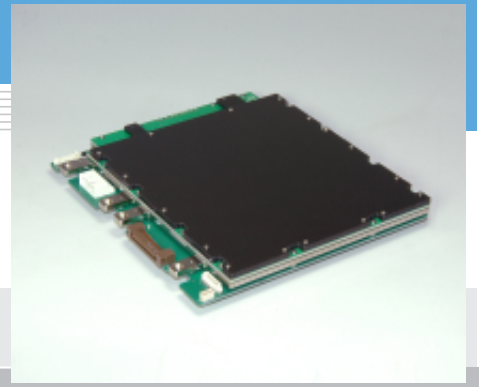

Flat panel sensor C10322D is a digital X-ray image sensor newly developed as key devices for real-time X-ray imaging.

Features

- For assembly into equipment (supplied without case)
- Wide dynamic range
- High sensitivity: 6000 LSB/mR
- High-speed frame rate: 30 frames/s
- 624 × 624 pixels
- Flat panel structure without image distortion
- 13-bit digital output

Applications

- Digital radiography
- Real time CT, etc.

Block diagram

C10322D is a lightweight and compact bare bone flat panel sensor consisting of a sensor board and a control board. The sensor board has 8 charge-sensitive amplifier arrays each having 78 ch amplifiers with a horizontal shift register. Analog video signals are amplified as the charge on each video line by 624 ch charge amplifiers with CDS (Correlated Double Sampling) circuits added, and are output each of 8 amplifier arrays. The control board converts the analog video signal into a 13-bit digital signal and outputs it to an external frame grabber through the 13-bit parallel port.

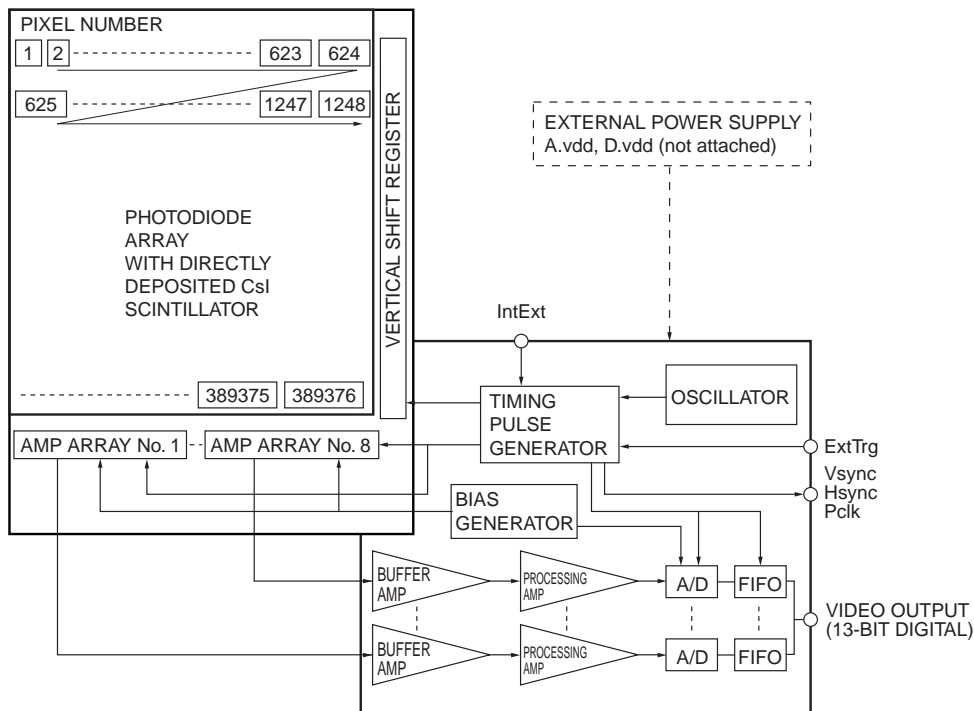

Note: Signals are read out in order of pixel number.

KACCC0237EB

General ratings

Parameter	Specification	Unit
Pixel size	200 × 200	μm
Photodiode area	124.8 × 124.8	mm
Number of pixels	624 × 624	pixels
Number of active pixels	608 × 616	pixels
Readout	Charge amplifier array	-
Video output (Data1 - 13)	LVDS (differential) 13 bit	-
Output data rate	15.15	MHz
Synchronous signal (Vsync, Hsync, Pclk)	LVDS (differential)	-
ExtTrg, IntExt	TTL	-
Scintillator	CsI	-

Absolute maximum ratings (Ta=25 °C)

Parameter	Symbol	Value	Unit
Supply voltage for digital circuitry (+5 V)	D.vdd	+6.0	V
Supply voltage for analog circuitry (+5 V)	A.vdd	+6.0	V
Input voltage (ExtTrg, IntExt)	Vin	0 to 6.0	V
Operating temperature *1	Topr	0 to +35	°C
Storage temperature *1	Tstg	0 to +50	°C

*1: No condensation.

Specification (Ta=25 °C, A.vdd= 5.0 V, D.vdd= 5.0 V)

Parameter	Symbol	Min.	Typ.	Max.	Unit
Frame rate (single operation)	Sf (int)	28.5	30	-	frames/s
Frame rate external	Sf (ext)	-	Sf (int) to 10	-	frames/s
Noise (rms) *2	N (rms)	-	2600	-	electrons
Saturation charge	Csat	-	8.3	-	M electrons
Sensitivity *3	S	4800	6000	-	LSB/mR
Resolution *4	Reso	2	2.5	-	line pairs/mm
Dynamic range	-	-	3200	-	-
Defect line *5	-	-	-	10	lines
Output offset *6	-	-	130	400	LSB

*2: Internal trigger mode, single operation

*3: 80 kVp, acrylic filter 170 mm

*4: Spatial frequency at CTF=5 %

*5: A defect line is a horizontal or vertical line containing 4 or more pixels that produce less than 5/8 of the average output from surrounding pixels and are formed continuously from the opposite side of an amplifier array or a vertical shift register. Without a couple of adjacent defect line.

*6: Average of all effective pixels in single operation at Sf (int)

Note: X-ray energy range is 20 k to 90 kVp.

Resolution

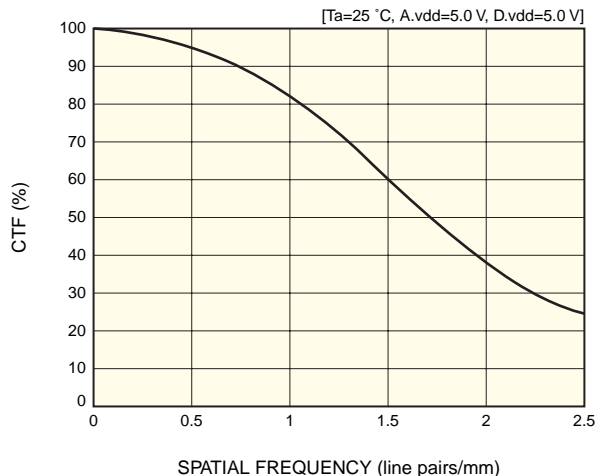

KACCB0136EA

■ Timing chart

To acquire images through an image grabber board, write parameters in the software program or parameter file by referring to the following timing chart and description.

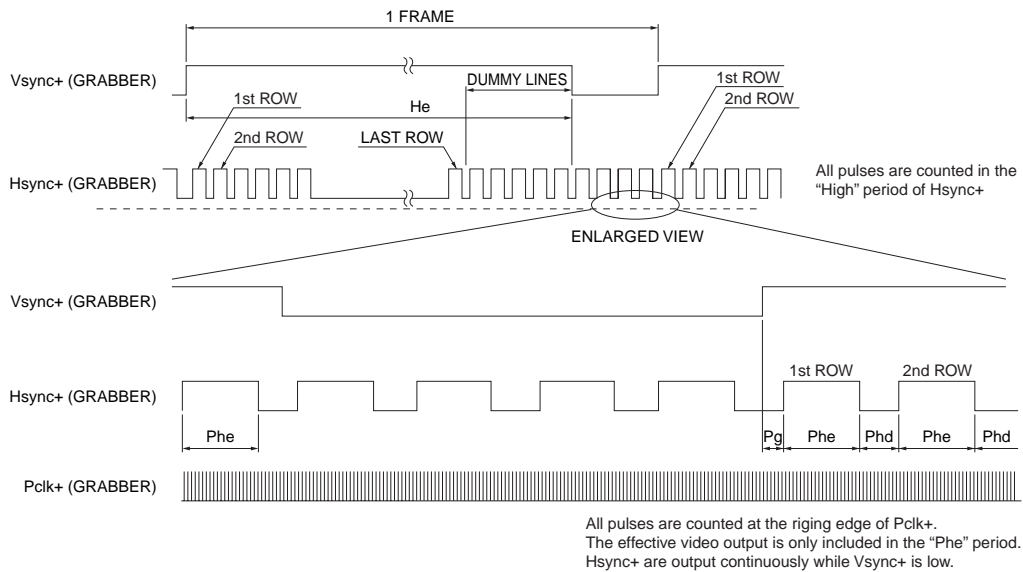

KACCC0361EB

Parameter		Count
He	Effective line	616
	Dummy line	8
Phe	Effective pixel	608
	Dummy pixel	16
Phd		177
Pg		157

Note: "He" is the Hsync count. Phe, Phd and Pg are the Pclk count.

■ External trigger mode

To acquire images in external trigger mode, input an external trigger pulse as shown below. When the time Tvd has passed after the rising edge of the external trigger pulse, synchronous signals and video signals are output.

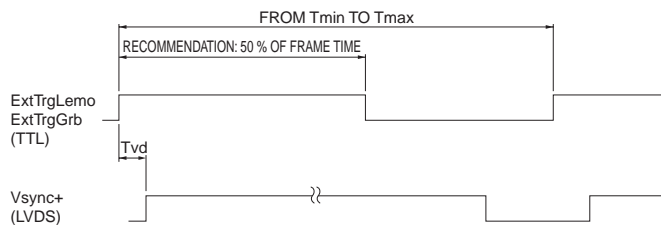

- Hsync+, Pclk+ and Data 1-13 are the same as internal trigger mode.
- Tmin is defined as 1/Sf (int).
 - Tmax is defined as the reciprocal of the minimum value of Sf (ext).
 - Tvd=96 μs

KACCC0351EA

■ System requirements

To operate C10322D at full performance, the following system and peripherals are required.

- PC: IBM compatible PC running on Windows XP
- Digital frame grabber card: Monochrome 16 bits or more, pixel clock 15.15 MHz or more, LVDS interface synchronous signal (See the frame grabber manual.)

The National Instruments IMAQ PCI-1424 (NI parts No. 777662-02) frame grabber has been verified to successfully acquire 13-bit digital images from C10322D. The IMAQ PCI-1422 (NI parts No. 777959-02) also acquires satisfactory images from C10322D. You can utilize the demonstration software that comes with the frame grabber as a simple viewer, to acquire and save an image. To do so, refer to the frame grabber user's guide for how to use the camera information file for the demonstration software.

- Power source: A.vdd = +5.0 ± 0.1 V (900 mA), D.vdd = +5.0 ± 0.1 V (250 mA)

Please use a low noise series power supply. (Avoid using a switching power supply.) A power cable and a frame grabber cable do not come supplied with C10322D.

The voltages described above are specified at the flat panel sensor side. Install a noise filter on the AC power input line to prevent surges on the AC line. The earth terminal must be connected to a stable earth point to eliminate noise from surroundings.

- No piece of acquisition software nor image processing library is attached to the sensor.

■ Pin connection

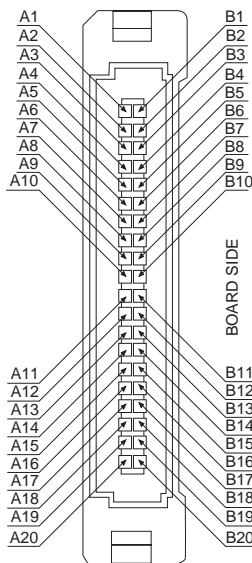

KACCC0356EA

Table 1: Pin assignment of 40-pin receptacle

Pin No.	Signal	Pin No.	Signal
A1	Data1+ (LSB)	B1	Data1- (LSB)
A2	Data2+	B2	Data2-
A3	Data3+	B3	Data3-
A4	Data4+	B4	Data4-
A5	Data5+	B5	Data5-
A6	Data6+	B6	Data6-
A7	Data7+	B7	Data7-
A8	Data8+	B8	Data8-
A9	Data9+	B9	Data9-
A10	Data10+	B10	Data10-
A11	Data11+	B11	Data11-
A12	Data12+	B12	Data12-
A13	Data13+ (MSB)	B13	Data13- (MSB)
A14	Reserved	B14	Reserved
A15	Reserved	B15	GND
A16	Reserved	B16	GND
A17	ExtTrg (TTL)	B17	IntExt (TTL)
A18	Vsync+	B18	Vsync-
A19	Hsync+	B19	Hsync-
A20	Pclk+	B20	Pclk-

Unless otherwise noted, signal level is LVDS.

40-pin receptacle: 8931E-040-178LF (KEL CORPORATION)

Mating plug: 8925R-040-179F (KEL CORPORATION)

Pins described "Reserved" are prepared for an extension of the future.

Do not connect any signal or power or GND to this plug.

Table 2: Power pin assignment

Pin No.	Signal
1	Digital GND
2	Digital +5 V
3	Analog GND
4	Analog +5 V
5	Shield (analog GND)

Power plug: 51067-0500 (Molex Japan Co., Ltd.)

Power receptacle: 53259-0529 (Molex Japan Co., Ltd.)

■ Connection

Install the digital frame grabber board into the PC by the manufacture's instructions. When a general-purpose frame grabber board is used, trigger operation for IntExt and ExtTrg can be controlled with its digital I/O control.

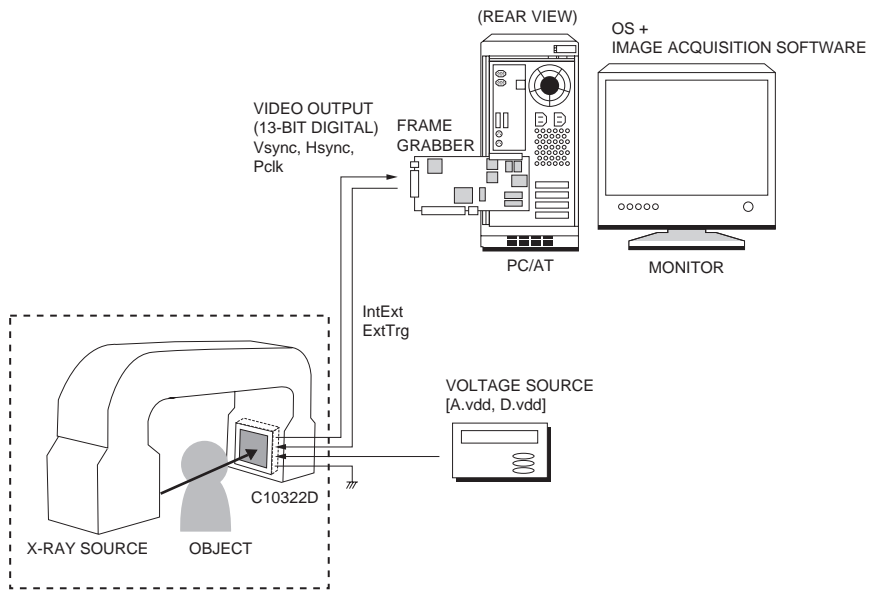

KACCC0357EA

■ Dimensional outline (unit: mm, tolerance: ± 1 mm unless otherwise noted)

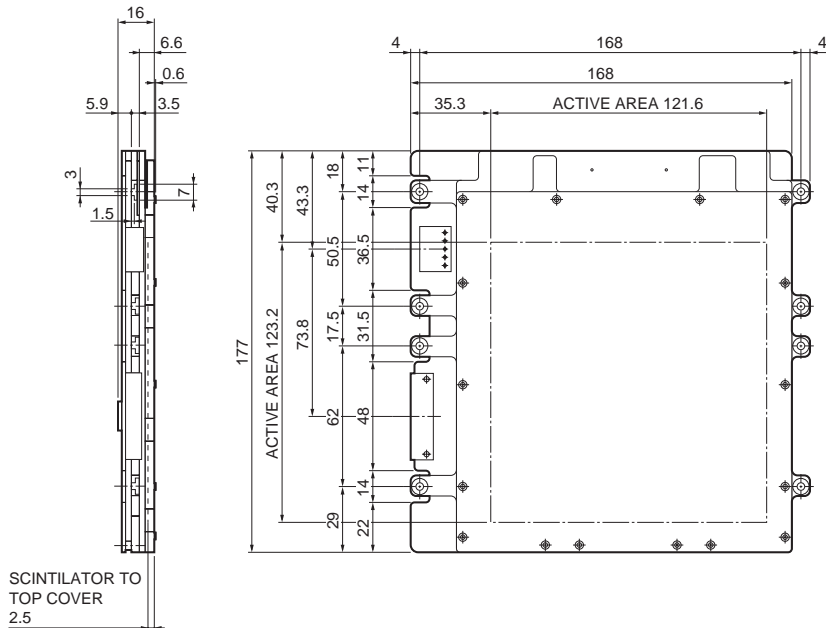

■ Notice

- Do not subject the Flat Panel Sensors to strong vibration or shock. (Strong shock such as drop impacts may cause permanent damage to these sensors.)
- Users must take responsibility for implementing X-ray shielding safety measures to avoid the risk of X-ray exposure.
- Data listed in this datasheet is defined at the time of shipment. Characteristics may vary somewhat due to exposure to X-rays so take proper countermeasures such as making periodic image correction.
- This product is warranted for a period of 12 months after the date of the shipment.

The warranty is limited to replacement or repair of any defective product due to defects in workmanship or materials used in manufacture. The warranty does not cover loss or damage caused by natural disaster, misuse (including modifications and any use not complying with the environment, application, usage and storage conditions described in this datasheet), or total radiation dose over 25000 Roentgen (90 kV) even within the warranty period.

HAMAMATSU

Information furnished by HAMAMATSU is believed to be reliable. However, no responsibility is assumed for possible inaccuracies or omissions. Specifications are subject to change without notice. No patent rights are granted to any of the circuits described herein. ©2007 Hamamatsu Photonics K.K.

HAMAMATSU PHOTONICS K.K., Solid State Division

1126-1 Ichino-cho, Higashi-ku, Hamamatsu City, 435-8558 Japan, Telephone: (81) 53-434-3311, Fax: (81) 53-434-5184, www.hamamatsu.com

U.S.A.: Hamamatsu Corporation: 360 Foothill Road, P.O.Box 6910, Bridgewater, N.J. 08807-0910, U.S.A., Telephone: (1) 908-231-0960, Fax: (1) 908-231-1218

Germany: Hamamatsu Photonics Deutschland GmbH: Arzbergerstr. 10, D-82211 Herrsching am Ammersee, Germany, Telephone: (49) 08152-3750, Fax: (49) 08152-2658

France: Hamamatsu Photonics France S.A.R.L.: 19, Rue du Saule Trapu, Parc du Moulin de Massy, 91882 Massy Cedex, France, Telephone: 33-(1) 69 53 71 00, Fax: 33-(1) 69 53 71 10

United Kingdom: Hamamatsu Photonics UK Limited: 2 Howard Court, 10 Tewin Road, Welwyn Garden City, Hertfordshire AL7 1BW, United Kingdom, Telephone: (44) 1707-294888, Fax: (44) 1707-325777

North Europe: Hamamatsu Photonics Norden AB: Smidesvägen 12, SE-171 41 Solna, Sweden, Telephone: (46) 8-509-031-00, Fax: (46) 8-509-031-01

Italy: Hamamatsu Photonics Italia S.R.L.: Strada della Moia, 1/E, 20020 Arese, (Milano), Italy, Telephone: (39) 02-935-81-733, Fax: (39) 02-935-81-741