



1345A DESIGNERS MANUAL

* COPYRIGHT HEWLETT-PACKARD COMPANY/COLORADO SPRINGS DIVISION 1981
1900 GARDEN OF THE GODS ROAD, COLORADO SPRINGS, COLORADO, U.S.A.

ALL RIGHTS RESERVED

TABLE OF CONTENTS (Cont'd.)

1345A DIGITAL DISPLAY IMPLEMENTATION	4-14
Simple Interface	4-15
DMA Interfaces	4-16
Smart Interface	4-17
SECTION V — 1345A PROGRAMMING	5-1
INTRODUCTION	5-1
PROGRAMMING EXAMPLES	5-2
Vector Plotting	5-2
Graph Plotting	5-3
1345A COMMANDS	5-4
Set Condition Command	5-4
Plot Command	5-6
Graph Command	5-9
Text	5-10
PROGRAMMING THE MEMORY OPTION (704)	5-15
Memory Board Commands	5-16
Address Pointer	5-17
Vector Memory Management	5-18
Memory Initialization	5-19
Reading the Vector Memory	5-19
DISPLAY PERFORMANCE CONSIDERATIONS	5-20
Refresh Rate	5-20
PICTURE COMPLEXITY	5-20
APPENDIX A — 1345A QUICK REFERENCE GUIDE	A-1
APPENDIX B — HP CLASS B SHOCK & VIBRATION TESTS	B-1
SHOCK AND VIBRATION	B-1
SHOCK TEST SPECIFICATIONS	B-1
INSTRUMENTATION	B-1
MOUNTING	B-1
PROCEDURE	B-2
RESULT	B-2
VIBRATION TESTS	B-2
MOUNTING	B-3
PROCEDURE	B-3
APPENDIX C — CONFIGURING THE 1345A VECTOR MEMORY (OPTION 704)	C-1

LIST OF FIGURES

Figure 1-1. Ambient Temperature Measurement	1-3
Figure 2-1. 1345A Operating Temperature Measurement	2-2
Figure 2-2. Dimensional Details of 1345A	2-3
Figure 2-3. Recommended Mounting Configuration	2-4
Figure 3-1. Power Connection for 1345A	3-1
Figure 3-2. Post Regulation Circuit for the HP Model 65317A Board Power Supply	3-2
Figure 3-3. 16-Bit I/O Connector	3-3
Figure 3-4. Cable Assembly Option 325	3-3
Figure 3-5. Primary Test Pattern	3-4
Figure 3-6. External Focus Potentiometer Connction	3-5
Figure 3-7. External Intensity Potentiometer Connection	3-5
Figure 3-8. Option 001 Cable Detail	3-6
Figure 3-9. Option 323 Cable Detail	3-7
Figure 4-1. Block Diagram Of A Typical Instrument Incorporating the 1345A	4-1
Figure 4-2. Vector Drawing Area	4-2
Figure 4-3. 1345A Functional Block Diagram	4-3
Figure 4-4. 1345A Rear Panel Connectors	4-4
Figure 4-5. RFD and DAV Handshake Sequence and Timing	4-5
Figure 4-6. Example Dual Port Memory Handshake Circuit	4-6
Figure 4-7. 1615A Timing Analyzer Diagram Of Example Circuit Handshake	4-7
Figure 4-8. Memory Read Timing	4-9
Figure 4-9. Memory Write Timing	4-10
Figure 4-10. Example Vector Memory Interface	4-11
Figure 4-11. Correct Test Pattern	4-13
Figure 4-12. Test Pattern With Defective Memory	4-14
Figure 4-13. 1345A Interfacing Techniques	4-14
Figure 4-14. Single Processor Interface	4-15
Figure 4-15. Typical DMA Interface	4-16
Figure 4-16. Example Smart Interface	4-17
Figure 5-1. 1345A 16 Bit Data Word	5-1
Figure 5-2. Binary to HEX Conversion	5-2
Figure 5-3. Vector Plotting	5-3
Figure 5-4. Graph Mode Example	5-4
Figure 5-5. Set Condition Command	5-5
Figure 5-6. Set Condition Examples in HEX	5-5
Figure 5-7. Plot Command Bit Pattern	5-6
Figure 5-8. Vector Defined By Endpoints	5-7
Figure 5-9. Plot Vector Example	5-7
Figure 5-10. Bit Definition For Graph Command	5-9

LIST OF FIGURES (Cont'd.)

Figure 5-11. Graph Mode Example	5-9
Figure 5-12. Text Command Bit Pattern	5-11
Figure 5-13. 1345A Character Display Capabilities	5-11
Figure 5-14. Example of 1X Character Spacing	5-12
Figure 5-15. 1345A Modified ASCII Character Set	5-12
Figure 5-16. Character Rotation	5-13
Figure 5-17. Character Rotation Spacing	5-13
Figure 5-18. Boundary Characters	5-14
Figure 5-19. Character Borders	5-15
Figure 5-20. Vector Memory Word	5-16
Figure 5-21. Internal Jump	5-16
Figure 5-22. Typical 1345A Vector Memory Map	5-17
Figure 5-23. Pointer Command Bit Pattern	5-17
Figure 5-24. Typical Instrument With Memory Option 704	5-18
Figure 5-25. Example Vector Memory Map	5-19
Figure 5-26. Synchronous Refresh	5-21
Figure 5-27. Asynchronous Refresh	5-21
Figure 5-28. Vector Length vs. Writing Speed for 60 Hz Refresh Rate	5-22
Figure 5-29. 1345A Capabilities for Character and Vector Combinations	5-23
Figure 5-30. Vector Drawing Time Calculations	5-23
Figure 5-31. Typical Spectrum Analyzer Presentation	5-24
Figure 5-32. A Typical Smith Chart Presentation	5-25
Figure 5-33. Additional 1345A Example Displays	5-26
Figure C-1. Internal/External Jumper Locator	C-1

LIST OF TABLES

Table 1-1. Specifications	1-1
Table 1-2. Supplemental Characteristics	1-3
Table 1-3. Standard Options	1-4
Table 2-1. Minimum Shock Level Withstand Capability	2-1
Table 2-2. Vibration Specifications	2-1
Table 4-1. Signal Line Characteristics of the 1345A	4-12
Table 4-2. Signal Line Characteristics of the 1345A With Memory Option Installed	4-12
Table B-1. Minimum Shock Level Withstand Capability	B-1
Table B-2. Vibration Specifications	B-3

GENERAL INFORMATION

INTRODUCTION.

The purpose of this Designer's Manual is to provide detailed information for installing, interfacing and programming the Model 1345A Digital Display. The manual is divided into five sections:

SECTION I — SPECIFICATIONS, OPTIONS, AND ACCESSORIES SUPPLIED.

SECTION II — MECHANICAL CONSIDERATIONS

SECTION III — ELECTRICAL CONSIDERATIONS

SECTION IV — I/O INTERFACING

SECTION V — PROGRAMMING

Included at the end of the manual is a Quick Reference Guide which contains programming examples and programming codes.

Listed on the back cover of this manual is a Microfiche part number. This number can be used to order 4- by 6-inch microfilm transparencies of the manual. Each microfiche contains up to 96 photoduplicates of the manual pages.

DESCRIPTION.

The Hewlett-Packard Model 1345A is a 15.24 cm (6 in.) Display Component. It produces vector graphics on its display screen in response to digital commands from a user processor. Because of its high resolution, 2048 X 2048 addressable points, the 1345A can draw both straight and curved lines. Curved lines are drawn by a series of short straight vectors.

The 1345A draws vectors at one of four writing speeds; this assures lines of uniform brightness, highlighted areas or lighter graticules. Erasing a vector that intersects another vector will not leave a blank space at the intersection.

At its faster drawing rate, and at 60 Hz refresh rate, the 1345A can draw a picture that contains up to 8194 cm (3226 in.) of vectors. If the refresh rate is slowed to 40 Hz, which is possible in some applications, then the picture can contain up to 12,288 cm (4838 in.) of vectors.

For labeling or identification of picture elements, the 1345A has a built-in set of ASCII characters which can be called out in the TEXT mode. The 1345A receives just one word from the the user processor and all the vectors necessary to form the character are automatically produced.

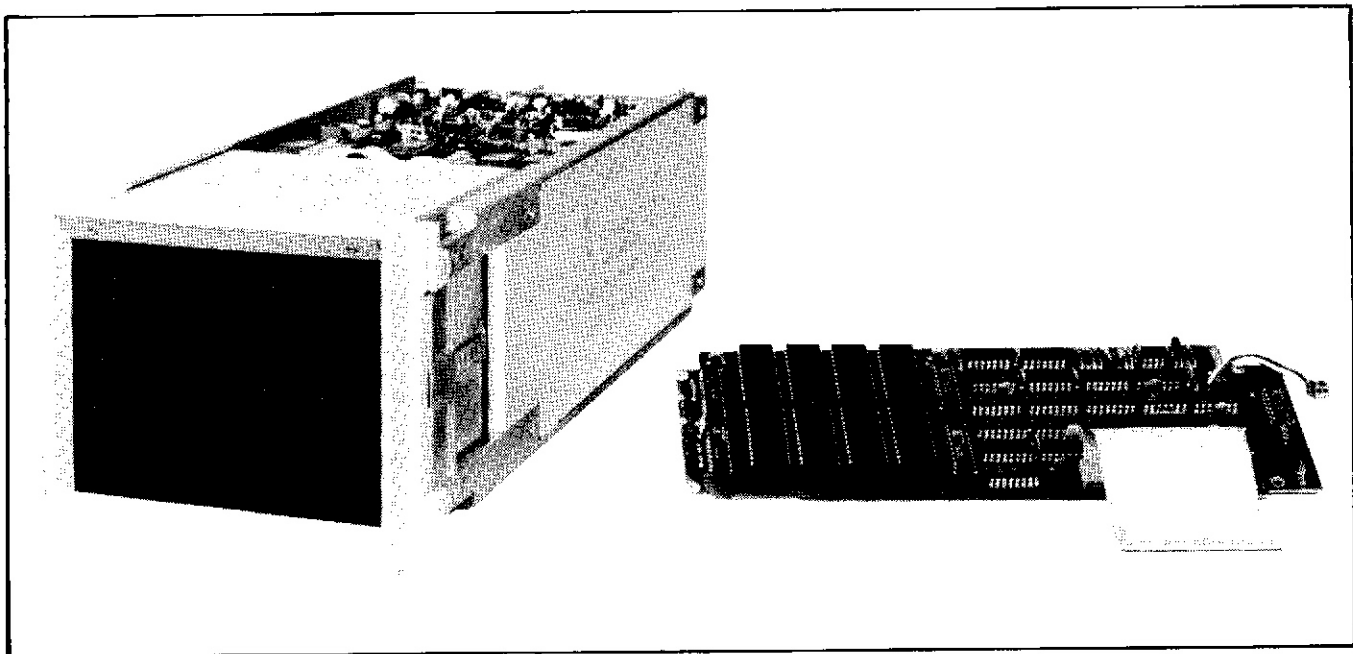

1345A Digital Display With Option 704

SECTION I

SPECIFICATIONS, OPTIONS AND ACCESSORIES SUPPLIED

INTRODUCTION.

This section lists the specifications, standard options available, and all accessories supplied with the Model 1345A.

SPECIFICATIONS.

Instrument specifications are listed in table 1-1. These specifications are the performance standards or limits against which the instrument is tested. Table 1-2 contains a list of supplemental characteristics. Supplemental characteristics are not specifications but are typical characteristics included as additional information for the user.

Table 1-1. Specifications

DIGITAL INPUT INTERFACE

SIGNAL LINES:

D00-D15: 16 Bit TTL Data Bus (positive logic)
RFD/A1: Handshake (ready for data)
DAV/WR: Handshake (data available)
SYNC: External Refresh Synchronization
RD: Memory Read
DS: Device Select
X ACK: Acknowledge
A0: Select Address
GND: Signal Ground

DISCONNECT SENSE: Signals Connector off, also activates self test when not grounded.

LOGIC LEVEL: Standard TTL

LOGIC LOAD: 1 Standard TTL Load

DATA ACCEPTANCE RATE: Controlled by 1345A, user processor and Vector length. Approximately 10 K words/second to 667 K words/second.

MATING CONNECTOR: 26-pin female transition connector; Mating Part 3M 3399-6026 (non-polarized), Ansley 609-2601M (non-polarized), Ansley 609-2630 (polarized) or equivalent.

GRAPHICS

RANDOM VECTOR PLOTTING: Addressable resolution 2048 × 2048 points
Programmable Automatic Delta-X Increment for Graphing.

3 PROGRAMMABLE INTENSITIES: Dim, Half Brightness, Full Brightness (Plus Blank or Off).

Table 1-1. Specifications (Cont'd.)

GRAPHICS (Cont'd.)

4 PROGRAMMABLE LINE TYPES: Solid Line, Solid Line with intensified endpoints, Short Dashes, Long Dashes.

4 PROGRAMMABLE WRITING SPEEDS: 1.27, 2.54, 3.81 and 5.05 mm/ μ s

VECTOR DRAWING TIME: $1\mu\text{s}/\text{vector} + (\text{Length of Vector divided by Writing Speed})$.

CHARACTERS

STROKE CHARACTERS: 36×24 point resolution; character strokes are stored in a plug-in ROM. Average character writing time is 16 μs .

4 PROGRAMMABLE CHARACTER SIZES:

1.0 \times 56 characters per line, 29 horizontal lines possible

1.5 \times 37 characters per line, 19 horizontal lines possible

2.0 \times 28 characters per line, 14 horizontal lines possible

2.5 \times 22 characters per line, 11 horizontal lines possible

4 PROGRAMMABLE CHARACTER ORIENTATIONS: 0, 90, 180, and 270 degrees (CCW) relative to horizontal.

X-Y-Z ANALOG OUTPUTS:

Amplitude: 0 to +1 volts; open circuit

Source Impedance: X and Y axis; approximately 340Ω

Z axis; approximately 250Ω

CATHODE-RAY TUBE

TYPE: Electrostatic focus and deflection, post accelerated. Aluminized P-31 phosphor.

SCREEN SIZE: 16 cm (6.25 in.) diagonal.

VIEWING AREA: 9.5 cm (3.75 in.) vertically by 12.5 cm (4.92 in.) horizontally.

BRIGHTNESS: 170 Cdm² at 2.5 mm per μs writing rate, full brightness at 60 Hz refresh rate.

SAFETY

X-RAY EMISSION: CRT emission 0.5 mr/hr (not measurable above background noise of Victoreen Model 440RF/C when in normal operating modes).

GENERAL

INPUT POWER REQUIREMENTS:

+15 Vdc $\pm 5\%$ regulated, 1.05 A, 10 mV p-p ripple.

+5 Vdc $\pm 5\%$ regulated, 0.75 A, 50 mV p-p ripple (note).

-15 Vdc $\pm 5\%$ regulated, 0.3 A, 10 mV p-p ripple.

NOTE

When 1345A is equipped with Option 704 (Vector Memory), current requirements for the +5 V supply are 1.8A.

POWER SUPPLY MATING CONNECTOR: Amp 1-350241-1 or equivalent.

Table 1-2. Supplemental Characteristics

OPERATING ENVIRONMENT**TEMPERATURE (operating):** 0° C to +65° C (+32° F to +130° F).**NOTE**

The 65° C (+130° F) temperature specification reflects the maximum allowable operating temperature with the 1345A enclosed, not the ambient temperature of the system interior. It is recommended that a minimum of 0.28 m³/min (10 ft³/min) of air flow is forced around the instrument to ensure that the maximum operating temperature of 65° C (+130° F) is not exceeded.

1345A TOP VIEW

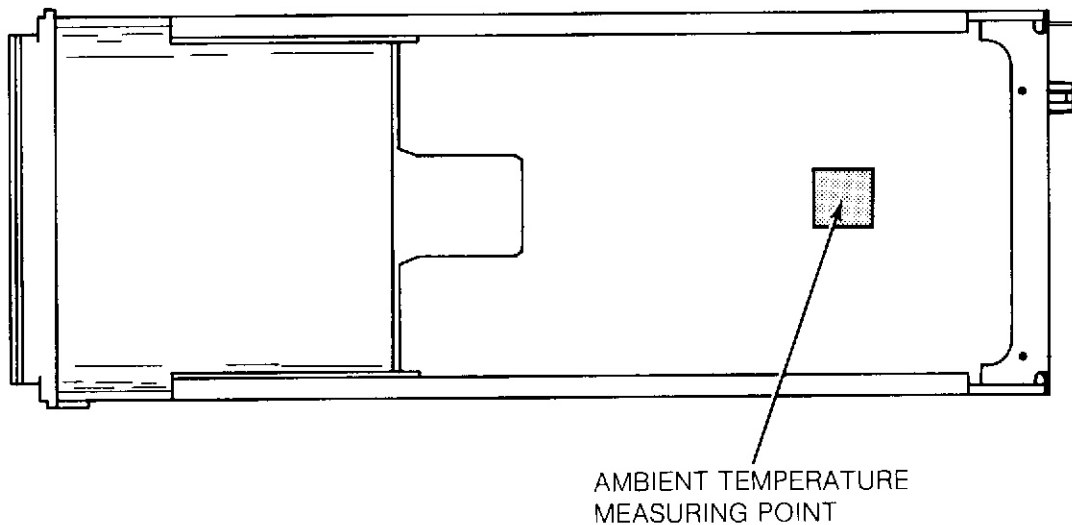

Figure 1-1. Ambient Temperature Measurement

TEMPERATURE (non-operating): -40° C to +70° C (-40° F to +70° F).**HUMIDITY:** to 95% relative humidity at +50° C (+104° F).**ALTITUDE:** (operating) to 4600 m, (15,000 ft); (non-operating) to 15,300 m, (50,000 ft).**SHOCK:** 30 g level with 11 ms duration and 1/2 sine wave shape.**VIBRATION:** vibrated in three planes for 15 min, each with 0.38 mm (.01 in.) excursion, 10 to 55 Hz.**SIZE:** see outline drawing.**WEIGHT:** net, 4.4kg, shipping weight 5.8 kg (13 lbs).**BEZEL:** Compatible with HP 197B camera equipped with 10375A adapter (order 197B option 006).

STORAGE ENVIRONMENT.

The instrument may be stored in environments within the following limits:

Temperature: -40° C to +70° C (-40° F to +158° F)

Humidity: up to 95% relative humidity at 50° C (+122° F)

Altitude: 15,000 m (50,000 ft)

The instrument should also be protected from temperature extremes which cause condensation within the instrument.

ACCESSORIES SUPPLIED.

The following accessories are supplied with the 1345A:

One Operating and Service Manual, HP stock number 01345-90901.

One Designer's Manual, HP stock number 01345-90902.

OPTIONS.

Standard options are modifications installed on HP instruments at the factory and are available on request. Table 1-3 is a listing of available options for the 1345A.

Table 1-3. Standard Options

Option	Description
001	Provides external Focus and Intensity controls
323	This option supplies X-Y-Z output cables for an external display. The cables are 61 cm (24 in.) long.
325	Provides a dc power input cable and an I/O interface cable. The cables are 91.5 cm (36 in.) long.
400	Metric Hardware Kit for Mounting the 1345A.
500	This option deletes the Operating and Service Manual.
505	This option deletes the Designer's Manual.
564	Provides a blue contrast filter in lieu of the standard neutral density filter.
704	This option adds 4 K X 16-bit Vector Memory.
910	This option provides an extra Operating and Service Manual.

SECTION II

MECHANICAL CONSIDERATIONS

INTRODUCTION.

This section contains detailed mechanical information about the Model 1345A. It contains dimensional details, location of center of gravity, suggested mounting configurations, and temperature considerations.

SHOCK AND VIBRATION.

The Model 1345A is designed to meet all HP Class B Shock and Vibration Standards. The instrument has been subjected to the shock and vibration levels as shown in tables 1 and 2. If the system is subjected to shock and vibration levels greater than those shown in table 1 and 2, then the instrument must be mounted to attenuate the applied shock and vibrations. For other shock amplitude or duration, the product of amplitude and duration must not be greater than the integral of 30 G peak, 11 ms duration, 0.5 sinewave. The design of the mounting must be checked by measuring the shock and vibration of the 1345A when mounted in the final configuration. The 1345A mass, center of gravity, and second moments of inertia information should only be used as a guide line for initial design of the system. The HP Class B specifications and procedures for Shock and Vibration are given in Appendix B at the end of this manual.

Table 2-1. Minimum Shock Level Withstand Capability

Class	Product Weight (kg)	Shock Intensity (g)	Shock Pulse Duration (milliseconds)
B	4.4 kg	30	11

Table 2-2. Vibration Specifications

Class	Frequency Hertz	Period Minutes	Amplitude Peak-Peak	Dwell Minutes	Amplitude Peak-Peak
B	5-55-5	15	0.38 mm (.015 in.)	10	Note 1

Note 1: 3.17 mm (0.125 in.) 5-10 Hz
 1.52 mm (0.060 in.) 10-25 Hz
 0.38 mm (0.015 in.) 25-55 Hz

TEMPERATURE CONSIDERATIONS.

It is recommended that the 1345A not be operated in environments where the instrument temperature can exceed $+65^{\circ}\text{C}$ ($+130^{\circ}\text{F}$). The $+65^{\circ}\text{C}$ ($+130^{\circ}\text{F}$) temperature specification reflects the maximum allowable operating temperature inside the 1345A, not the ambient temperature of the system. The operating temperature of the 1345A is measured 0.64 cm (0.25 in.) above the X-Y-Z/STROKE GENERATOR BOARD (A1) with the 1345A installed in the system (see point A in figure 2-1). It is also recommended that a minimum of $0.28\text{ m}^3/\text{min}$ ($10\text{ ft}^3/\text{min}$) of air flow is forced around the instrument to ensure that the maximum allowable operating temperature of $+65^{\circ}\text{C}$ (130°F) is not exceeded.

The surface temperature at points "B" in figure 2-1 may typically be $+50^{\circ}\text{C}$ ($+122^{\circ}\text{F}$) or more above the ambient temperature. It is therefore recommended that heat-sensitive devices or circuits not be placed in close proximity to these points.

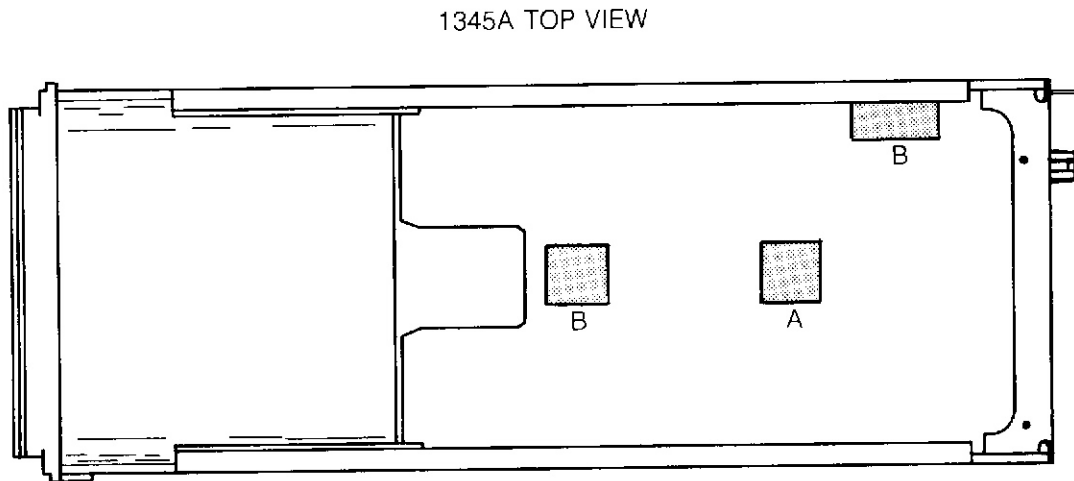
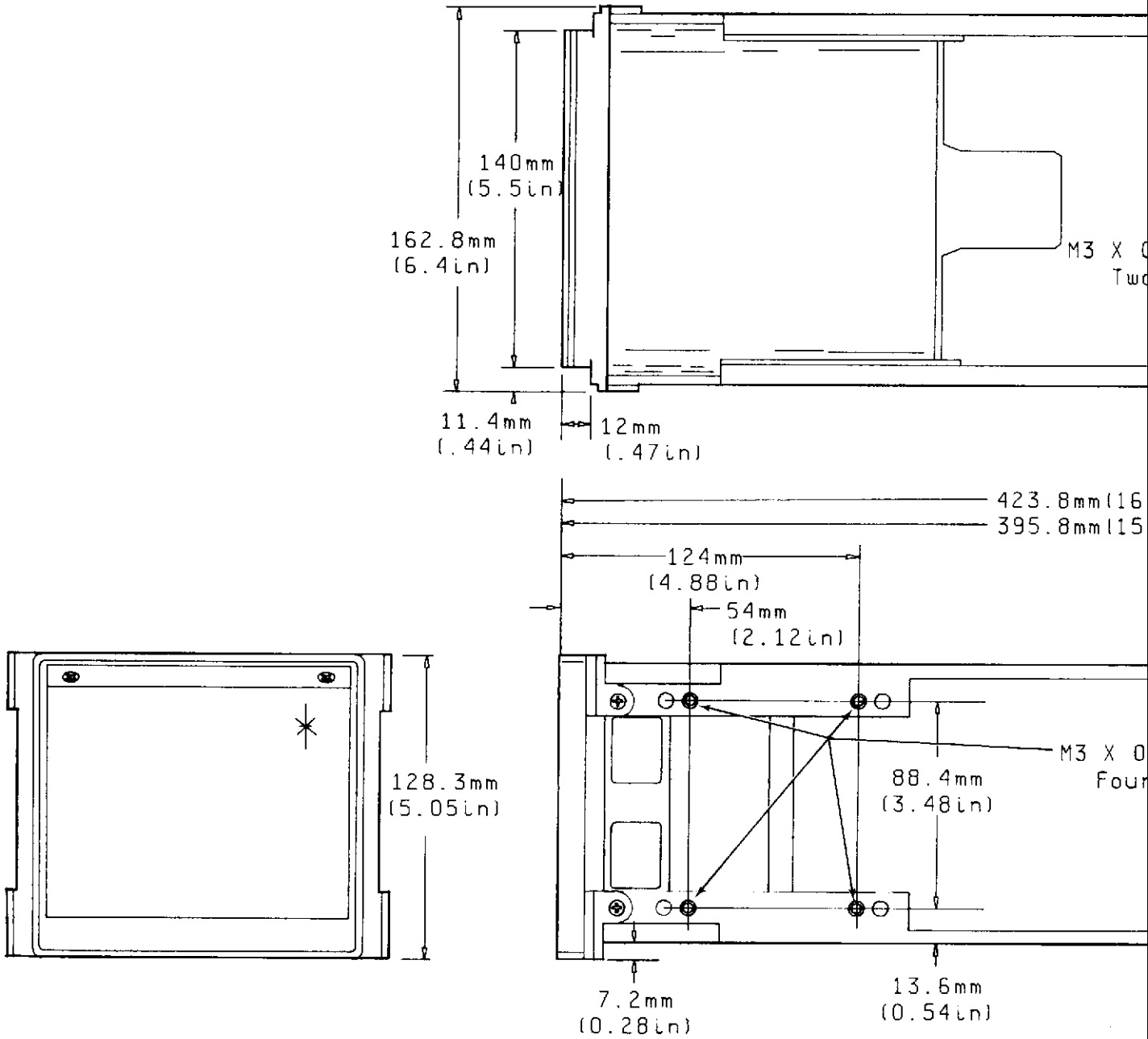

Figure 2-1. 1345A Operating Temperature Measurement

DIMENSIONAL DETAILS.

The dimensional details of the 1345A are shown in figure 2-2. Dimensions that are shown in parentheses are in inches, dimensions not in parentheses are in metric (millimeters).



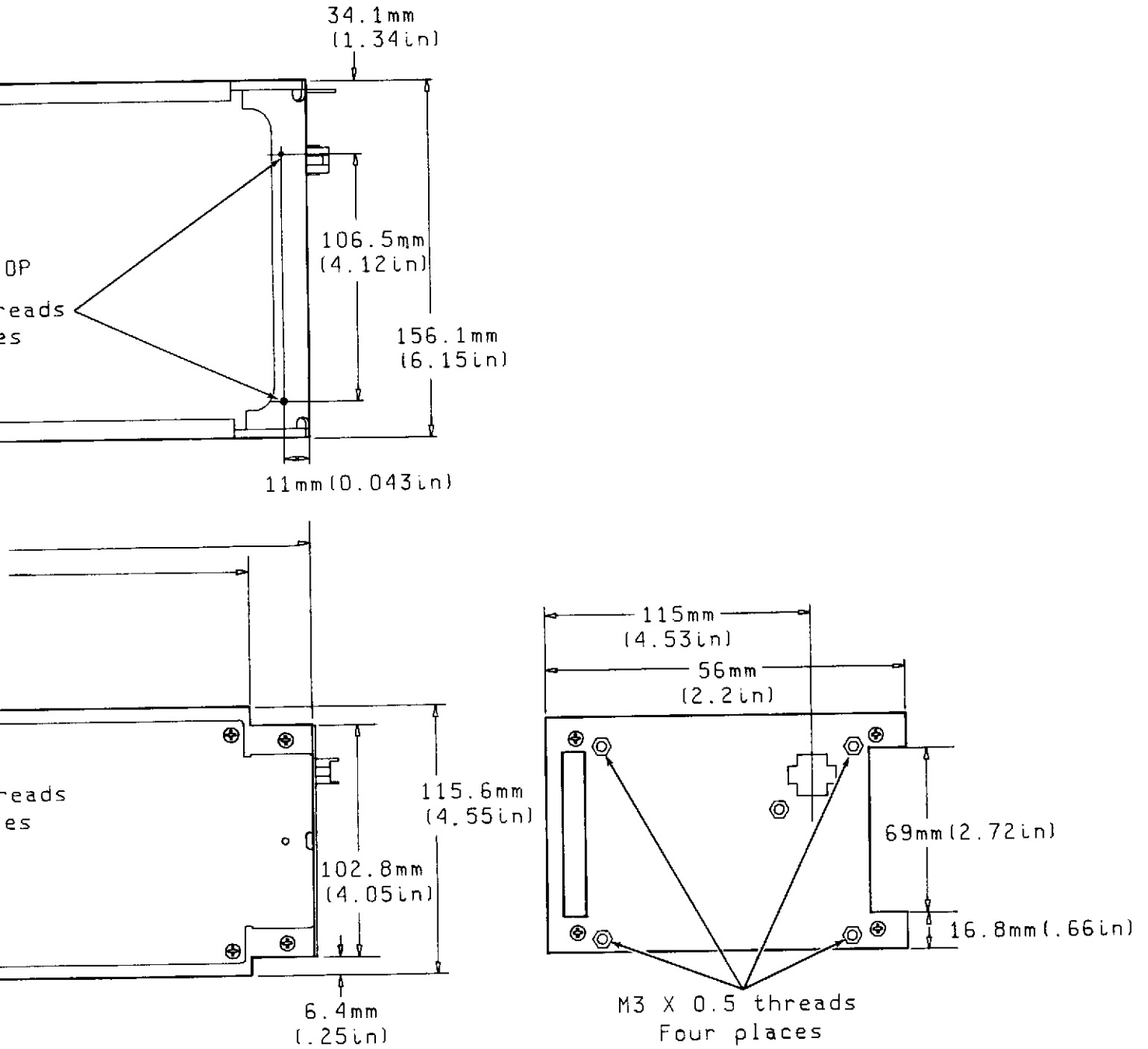

Figure 2-2. Dimensional Details of 1345A

MOMENTS OF INERTIA.

The second moments of inertia I_x , I_y , I_z about the major axis as defined in figure 2-4 through the center of gravity of the 1345A are listed below:

I_z : 150 cmgm sec² (0.13 in.lb sec²)

I_x : 670 cmgm sec² (0.58 in.lb sec²)

I_y : 716 cmgm sec² (0.62 in.lb sec²)

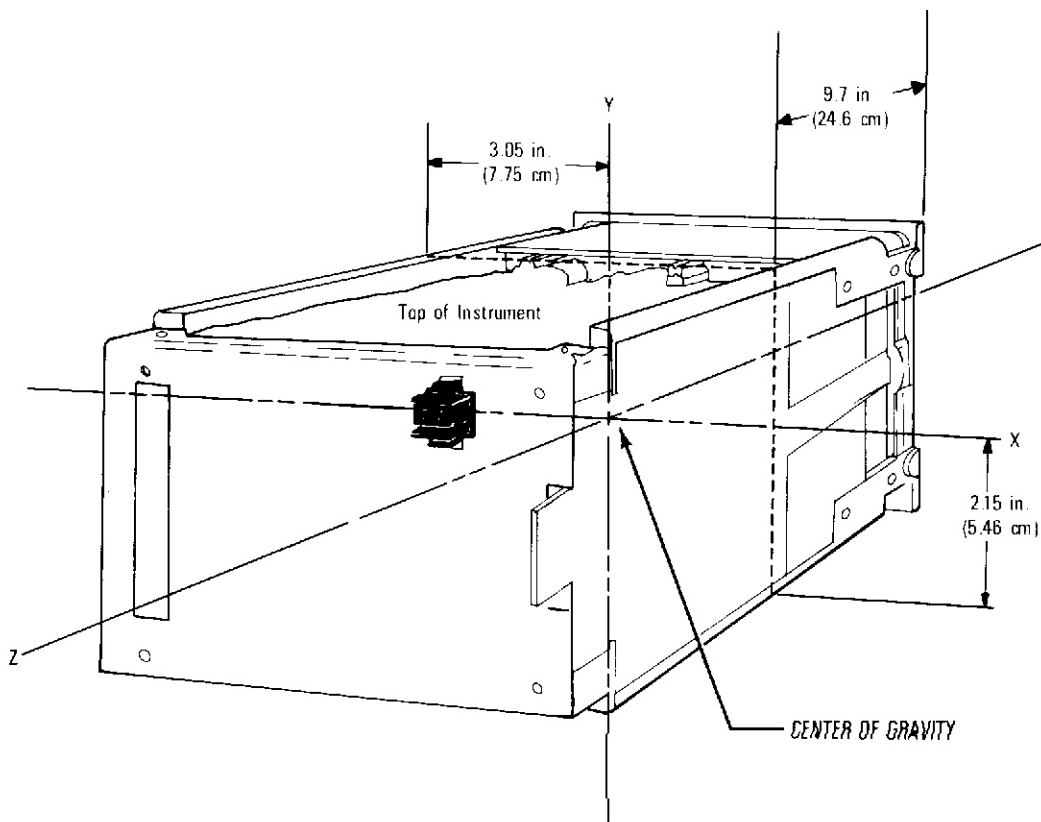
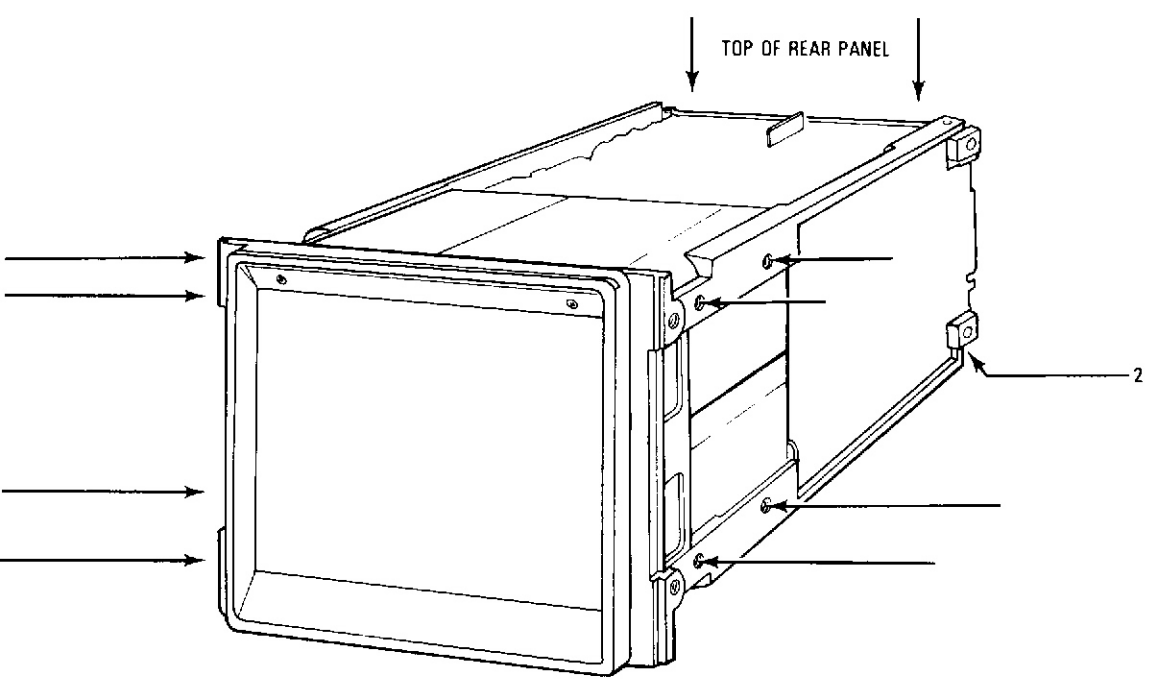

Figure 2-4. Definition of Moments of Inertia and Center of Gravity

MOUNTING CONFIGURATION.

The recommended mounting configuration for the 1345A is shown in figure 2-3. It is recommended that the instrument be supported at the front side casting and rear panel mounting holes.



USE M3 × 0.5 THREADS FOR MOUNTING 1345A INTO THE SYSTEM

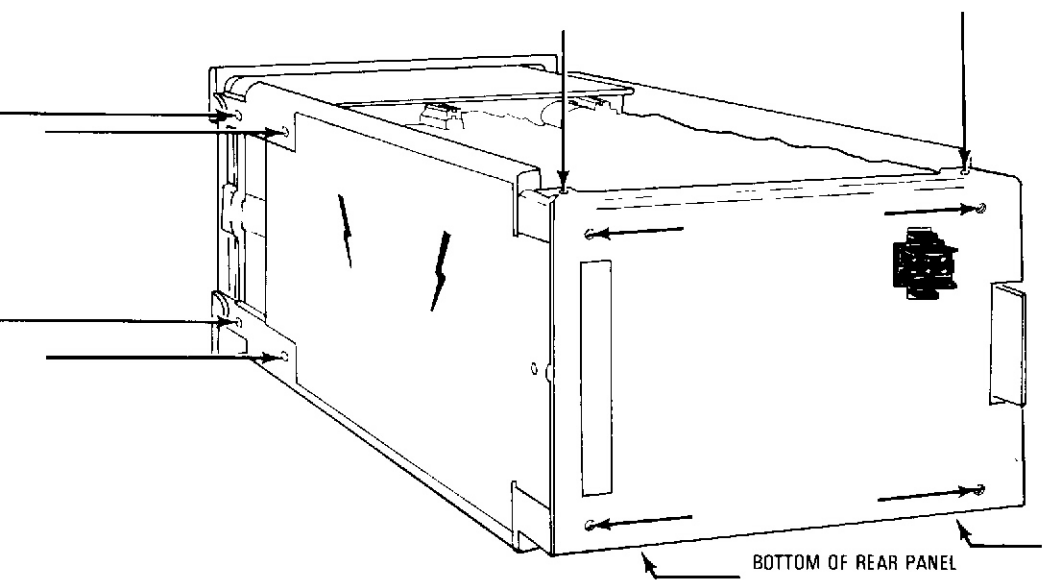

Figure 2-3. Recommended Mounting Configuration

SECTION III

ELECTRICAL CONSIDERATIONS

INTRODUCTION.

This Section contains electrical information about the 1345A. It deals with power requirements, power supply recommendations, I/O interfacing, and characterization of the X-Y-Z outputs. A brief description of external Intensity and Focus controls (Option 001) will also be given.

POWER REQUIREMENTS.

The 1345A requires the following power supplies for proper operation:

- +15 Vdc $\pm 5\%$ regulated, 1.05 A, 10 mV p-p ripple
- +5 Vdc $\pm 5\%$ regulated, 0.75 A, 50 mV p-p ripple (note)
- 15 Vdc $\pm 5\%$ regulated, 0.3 A, 10 mV p-p ripple

NOTE: When the 1345A is equipped with Option 704 (Vector Memory), current requirements for the +5 V supply are 1.8 A.

POWER CONNECTOR.

A 6 Pin connector (Amphenol 1-350241-1 or equivalent) is required to mate with the rear panel power connector.

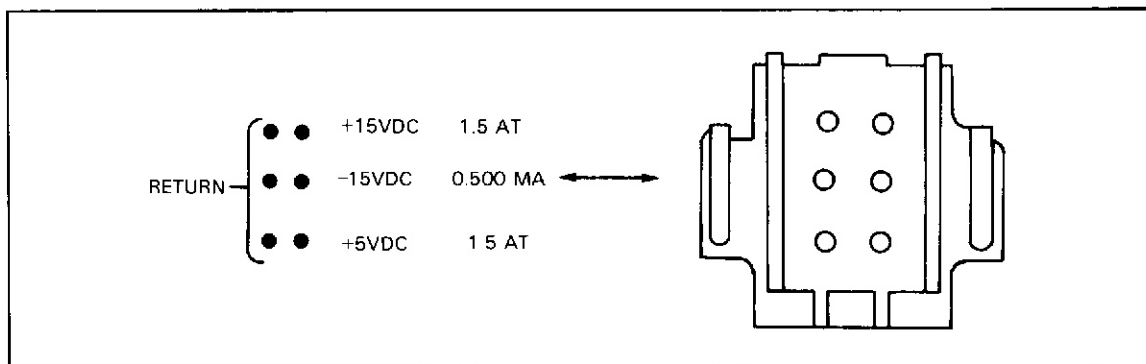

Figure 3-1. Power Connection for 1345A

POWER SUPPLY RECOMMENDATIONS.

For bench testing, calibration and design work the HP Model 63315D Power Supply may be used. This OEM Power Supply is not recommended for use as the power source in systems using the 1345A because its output ripple specification is greater than that specified for the 1345A. For OEM applications, the HP Model 65317A Power Supply is recommended based on evaluations performed in our labs. This power supply requires additional post regulation on the +15 V and the -15 V supply to reduce the output ripple to the levels required by the 1345A. A suggested post regulation circuit for the HP Model 65317A is shown in figure 3-2. The circuit shown in figure 3-2, is designed to provide power for only one 1345A. If additional current or voltages for other circuits within the system are required, then other HP Power Supplies in the 65000 series may be substituted or added on to the 65317A power Supply.

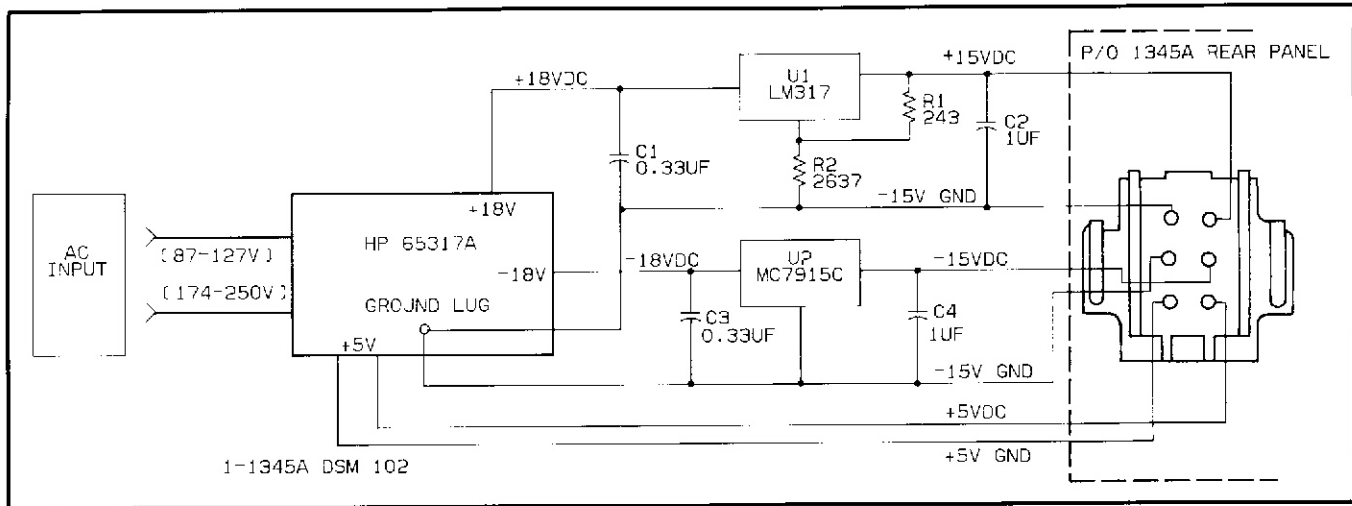

Figure 3-2. Post Regulation Circuit for the HP Model 65317A Board Power Supply

I/O CONNECTOR.

A 26 pin connector (ANSLEY 609-2630 or equivalent) is required to mate with the rear panel connector. The connector is wired according to figure 3-3.

OPTION 325.

This Option provides a DC power input cable and an I/O interface cable with connectors that interface with the 1345A. The cables are 91.4 cm (36 in.) long and have stripped ends on the other end for connection to the user's circuit.

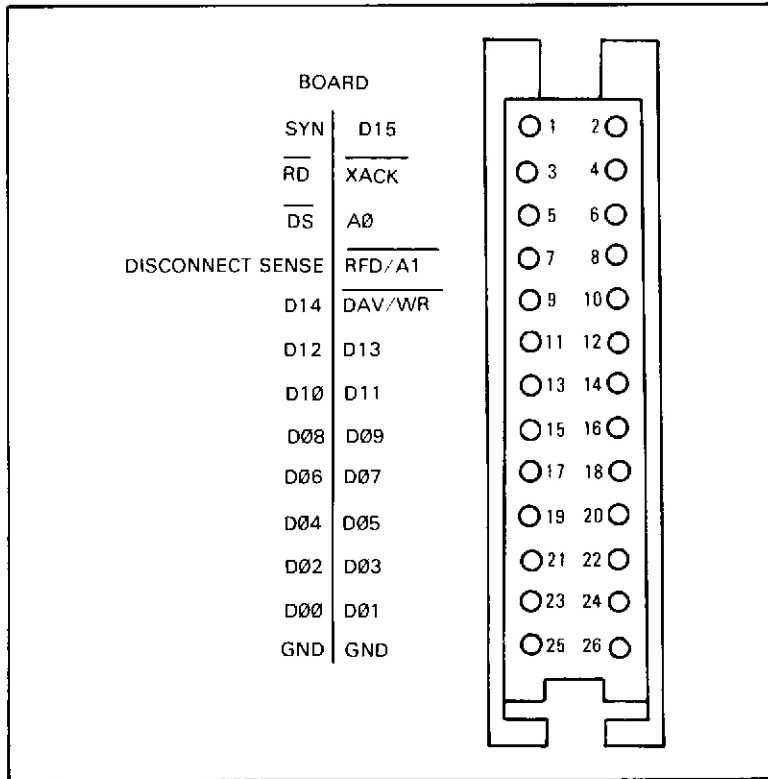

Figure 3-3. 16-Bit I/O Connector

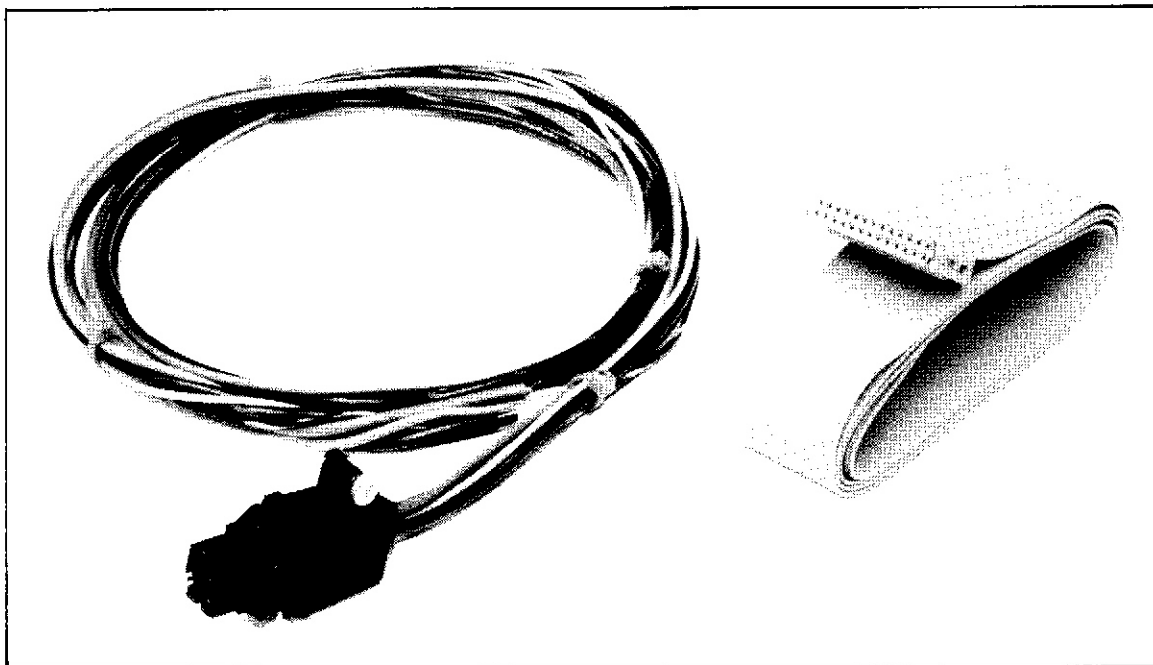

Figure 3-4. Cable Assembly Option 325

PRIMARY TEST PATTERN.

When the I/O port is not connected and power is applied to the 1345A, the Primary Test Pattern will be displayed. The test Pattern is used for performance verification and calibrating the Digital Display. Should it become necessary to service the 1345A refer to the 1345A Operating and Service Manual Section V and Section VIII. If a smaller display on the 1345A screen is desired, the X and Y gain adjustments may be recalibrated for a smaller picture.

NOTE

The test pattern can also be displayed by programming the user processor. See Section V of this document for programming details.

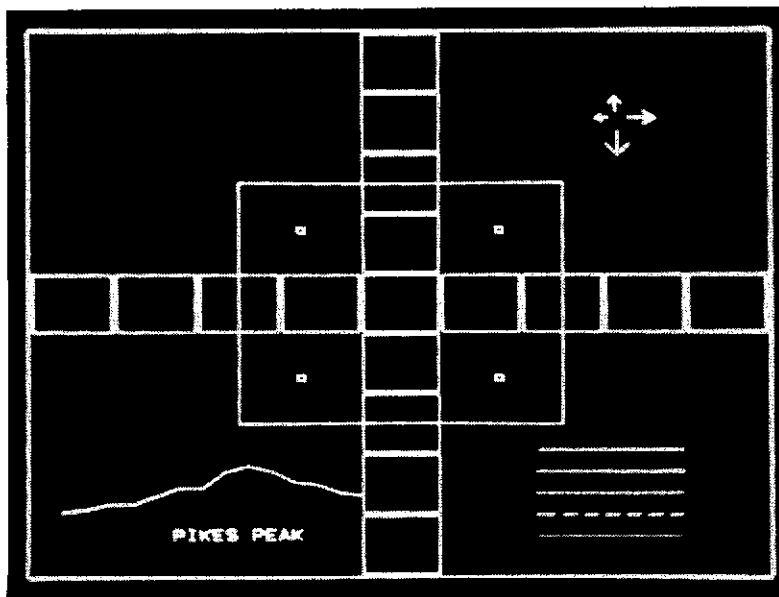

Figure 3-5. Primary Test Pattern

EXTERNAL FOCUS AND INTENSITY CONTROL.

Focus and intensity may be controlled from the front panel if external controls are added. Connectors are provided on the Stroke Generator Board (A1) for adding the controls. The External Intensity Control potentiometer should have a value of 1K ohms and the Focus Control potentiometer should have a value of 5K ohms. The potentiometers should have a tolerance of no greater than 10%, should be linear tapered and a wattage rating of ≥ 1 W. The external control connections should be made according to the following schematics:

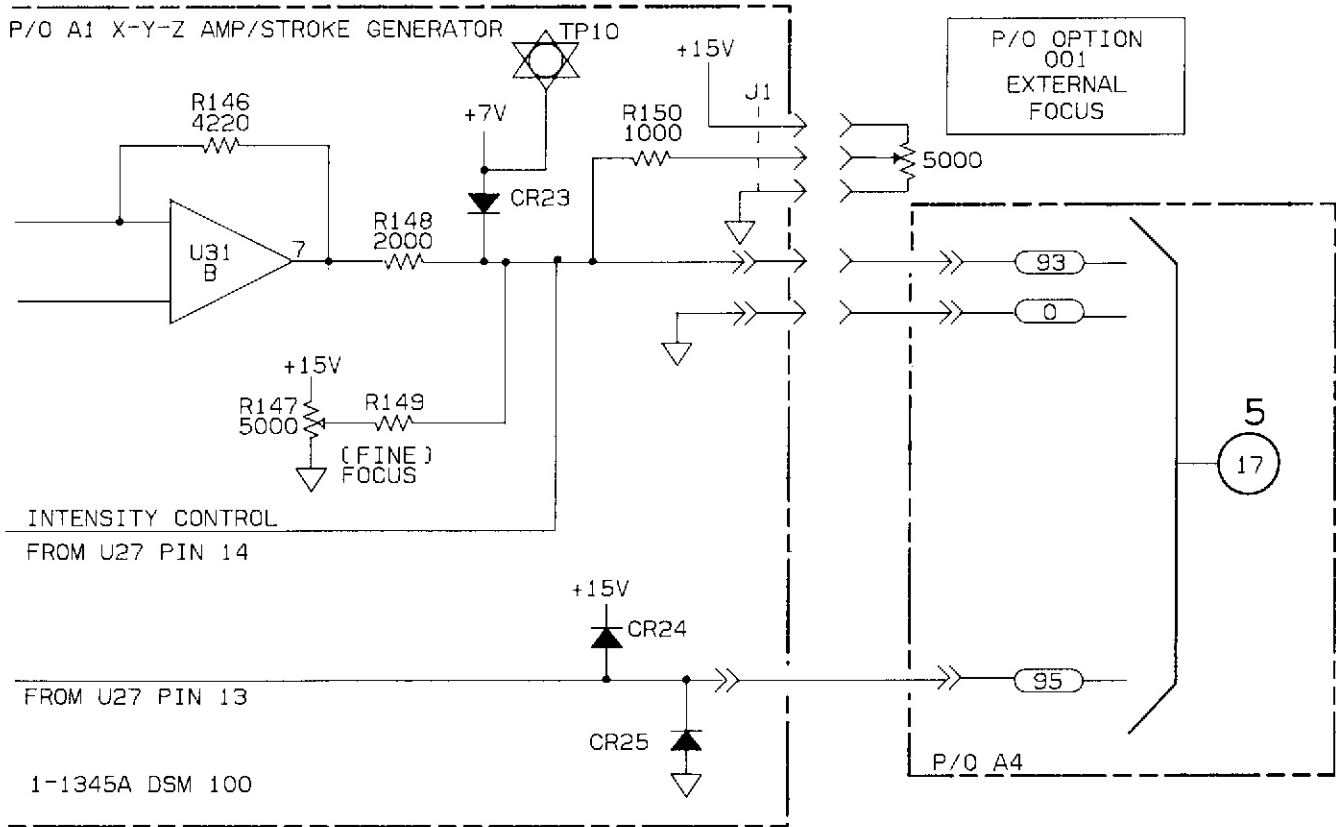

Figure 3-6. External Focus Potentiometer Connection.

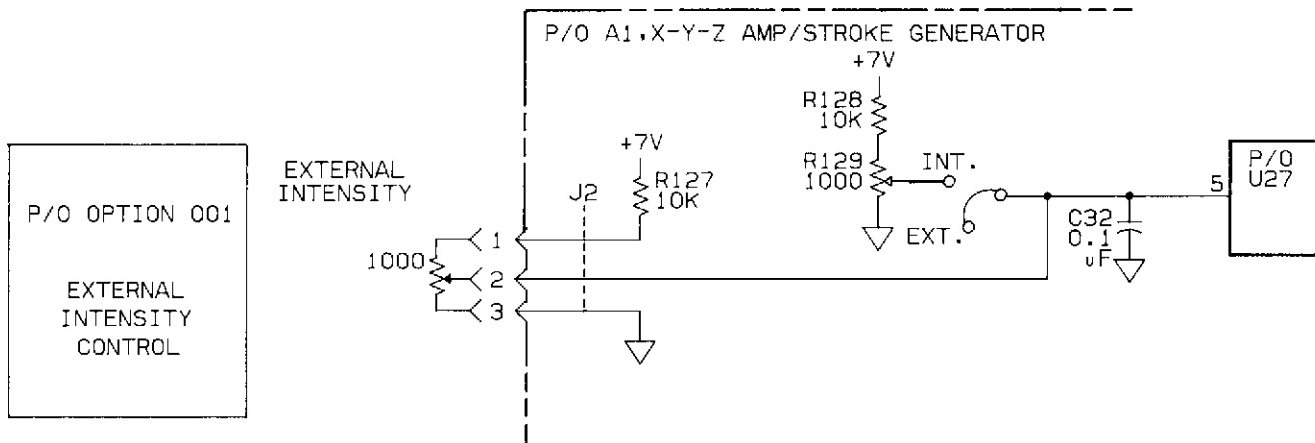

Figure 3-7. External Intensity Potentiometer Connection.

OPTION 001.

Option 001 provides all the necessary materials for external Focus and Intensity control. The cables between the Stroke Generator Board and the Focus and Intensity pots are 60.9 cm (24 in.) long.

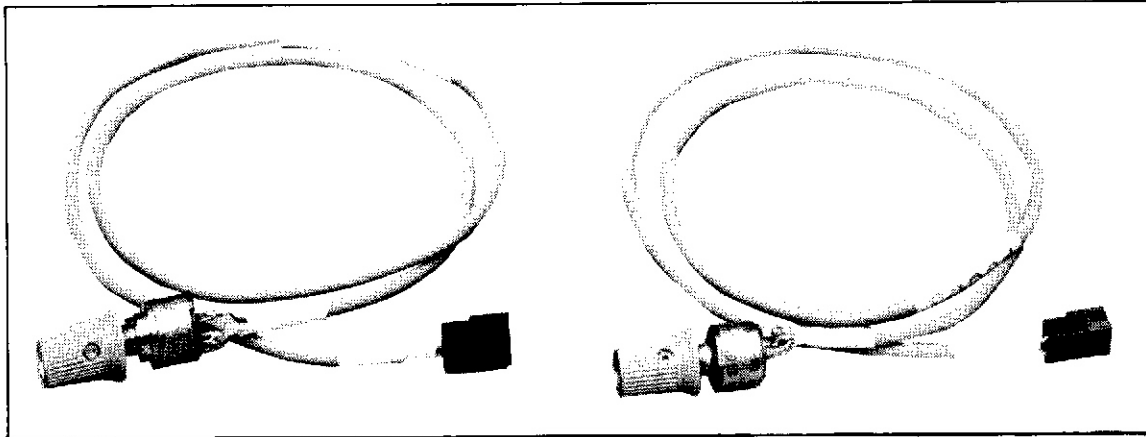

Figure 3-8. Option 001 Cable Detail

X-Y-Z AXIS OUTPUTS.

The X-Y-Z Outputs can drive another peripheral such as a large screen display. In order to reproduce the high resolution display of the 1345A, the added peripheral should have a bandwidth of 5 MHz or greater. The open circuit amplitude of the X and Y axis output signals range from 0 to 1 V from a source impedance of approximately 340Ω . The Z axis open circuit amplitude is the same however the source impedance is approximately 250Ω . These output circuits are designed for use with Hewlett-Packard large screen displays with $10\text{ K}\Omega$ input impedances. These outputs cannot drive impedances less than 600Ω . It is recommended that shielded cable be used between the X-Y-Z outputs and the peripheral. The outer conductor of the cable should be grounded at each end. Connect the X-Y-Z outputs according to the table below:

X OUTPUT — A1J5

Y OUTPUT — A1J4

Z OUTPUT — A1J3

A two pin female metric post type connector (Molex 22-01-1023 or equivalent) is required to mate with the X-Y-Z output connectors. If the X-Y-Z output cables used are longer than 61 cm (24 in.) then driver amplifiers with the following characteristics must be designed:

BANDWIDTH: 50 MHz (7 ns rise time with 1% perturbation).

SETTLING TIME: 100 ns.

OUTPUT IMPEDANCE: 50 ohms.

OUTPUT VOLTAGE: 0 Vdc to 1 Vdc into 50 ohms.

OPTION 323.

Option 323 provides output cables for the X-Y-Z outputs. The cables are 60.9 cm (24 in.) long and are ready to connect to the X-Y-Z outputs on the Stroke Generator Board (A1). The other end of the cables have stripped ends for connection to the user's circuit.

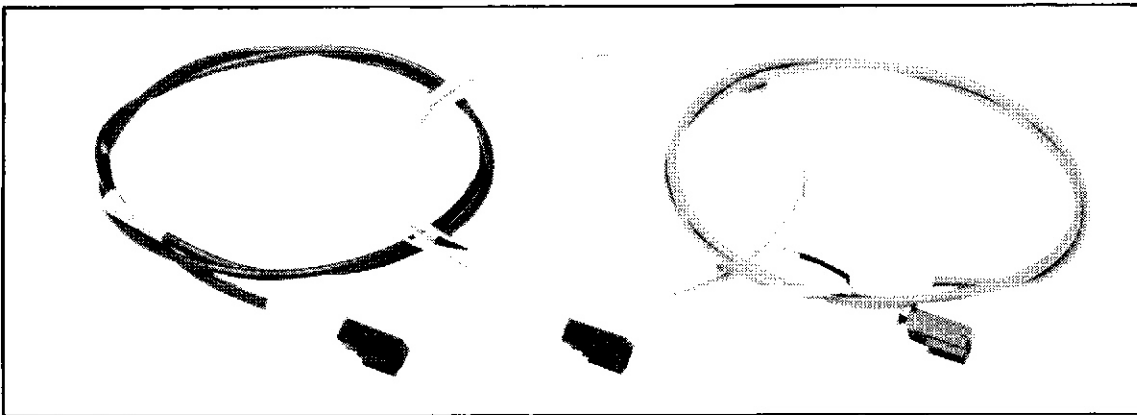

Figure 3-9. Option 323 Cable Detail

SECTION IV

I/O INTERFACING

INTRODUCTION.

Interfacing a model 1345A Digital Display into typical instrumentation applications requires that the user be familiar with the operational characteristics and interface requirements of the 1345A. This section of the DESIGNERS MANUAL will introduce the required components of a typical 1345A display interface, electrical characteristics and implementation techniques.

THE DISPLAY ENVIRONMENT.

A typical user instrument will acquire, manipulate and format the data to be displayed on the 1345A CRT. The 1345A accepts commands via a 16 bit data bus from the user instrument. The instrument illustrated in figure 4-1 has three separate functional blocks. The most important of these, is the user processor. This is typically a microprocessor that is programmed to control measurement and data handling tasks of the instrument. Data acquisition is handled by the instruments data acquisition circuitry. The data may or may not be processed by the user processor before being sent to the 1345A via a user designed 1345A interface. The purpose of the interface is to handle data transfers to the 1345A. If the optional Vector Memory is installed, the 1345A 16 bit data bus is bidirectional and the interface may need to handle bidirectional data transfers.

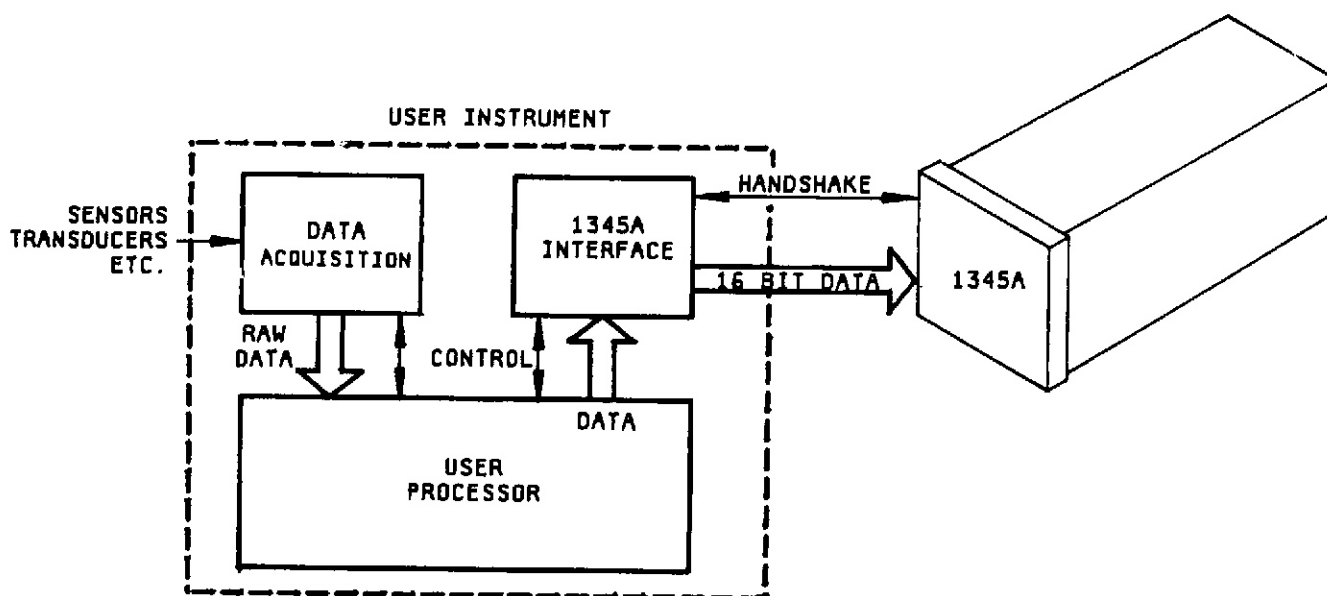

Figure 4-1. Block Diagram Of A Typical Instrument Incorporating the 1345A

The 1345A Digital Display.

The 1345A is a Digital Display Module that creates vectors by the "random vector plotting" technique. Each vector is defined by end points in a 2048×2048 point cartesian coordinate plane. All end points are positive with respect to the origin located in the lower left corner of the CRT screen. Figure 4-2 is a diagram of the 1345A CRT coordinate area with several vectors defined. A vector can be drawn with the beam either on or off. Figure 4-2 contains 5 vectors defined by their endpoints. The dashed line represents a vector with the beam off. The vector data sent to the 1345A are the values of the X and Y coordinates of 0-2047 as specified.

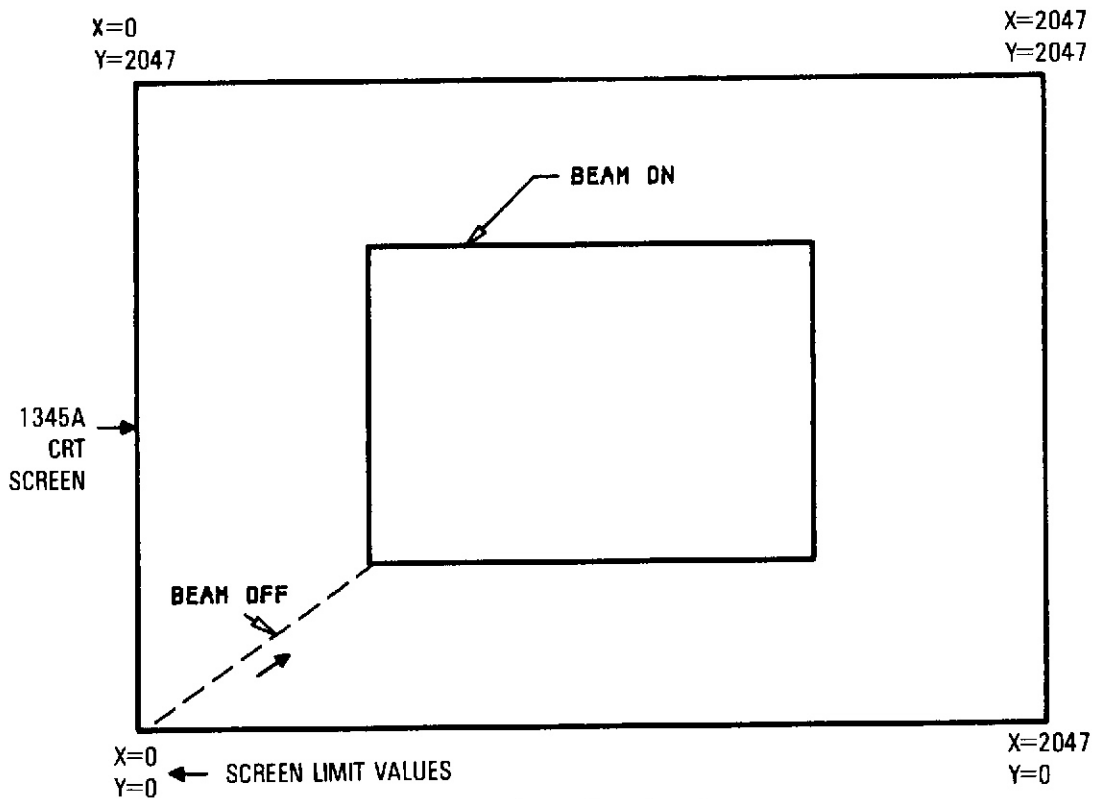

Figure 4-2. Vector Drawing Area

Several operations occur to transform the coordinate values of the vector data into vectors displayed on the 1345A screen. These operations are outlined by the functional blocks of the 1345A shown in figure 4-3. The 1345A accepts defined commands from the user interface via a 16 bit data bus. These 16 bit data words are decoded into the 1345A commands PLOT, GRAPH, TEXT, and SET CONDITION. Section V of this manual contains complete descriptions of these commands.

The following descriptions highlight the main functional blocks of the 1345A.

Power Supply. The power supply generates the required voltages to drive the CRT.

Vector Processor. The Vector Processor converts the 16 bit input vector data into defined vectors. The Vector Processor receives 16 bit data using a two wire handshake which is controlled by the Vector Processor and the 1345A. The 16 bit input data is decoded into one of four commands that plot either vectors or text using an internal character generator.

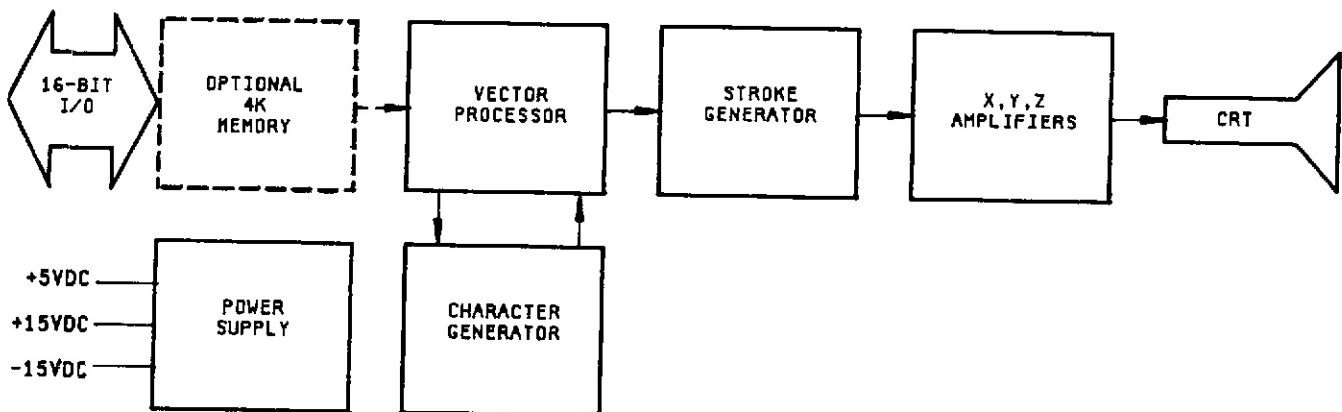

Figure 4-3. 1345A Functional Block Diagram

Stroke Generator. The Stroke Generator converts the digital vector data from the Vector Processor into vectors displayed on the CRT. The stroke generator can be programmed to give several combinations of line types, intensities, and writing speeds.

X-Y-Z Amplifiers. The vectors created in the Stroke Generator are amplified to levels needed to drive the CRT. The X and Y signals are inputs to positional focus correction circuitry. The Z signal is input to beam drive correction circuitry. The two correction circuits insure a focused circular dot in all areas of the CRT at all intensities.

CRT. The 1345A uses an electrostatically deflected CRT to provide fast writing speeds, low power consumption, and high resolution. The 1345A has a P-31 phosphor CRT screen that should be refreshed at least 60 times a second to avoid display flicker. This means the picture should be retraced, or refreshed at least once every 16.6 ms.

Vector Memory (Option 704). The 1345A may be ordered with an optional 4K by 16 bit memory that functions as an auxiliary read/write memory for the user system. This allows the user to write the vector data to the vector memory only once. The vector memory will then handle the refresh requirements of the display. This memory can store and refresh up to 4096 commands. The vector memory has an internal refresh timer that generates a refresh cycle approximately once every 16.6 ms.

User Instrument Requirements.

The 1345A is designed as an internal display component for instrumentation. The user instrument must provide the required DC voltages +5 Vdc, +15 Vdc, and -15 Vdc. These are supplied through the rear panel power connector. The user instrument must also provide to the 1345A the data that is to be displayed. The I/O and power connectors are shown in figure 4-4. Data may be gathered from transducers, sensors, etc. and may or may not be processed or modified by software algorithms prior to being displayed. The user instrument must perform any data manipulation tasks. The 1345A will display only formatted vector data. The format of the data corresponds to the four commands that the 1345A can recognize. These are PLOT, GRAPH, SET CONDITION, and TEXT. The formats for these commands are described in section V of this manual.

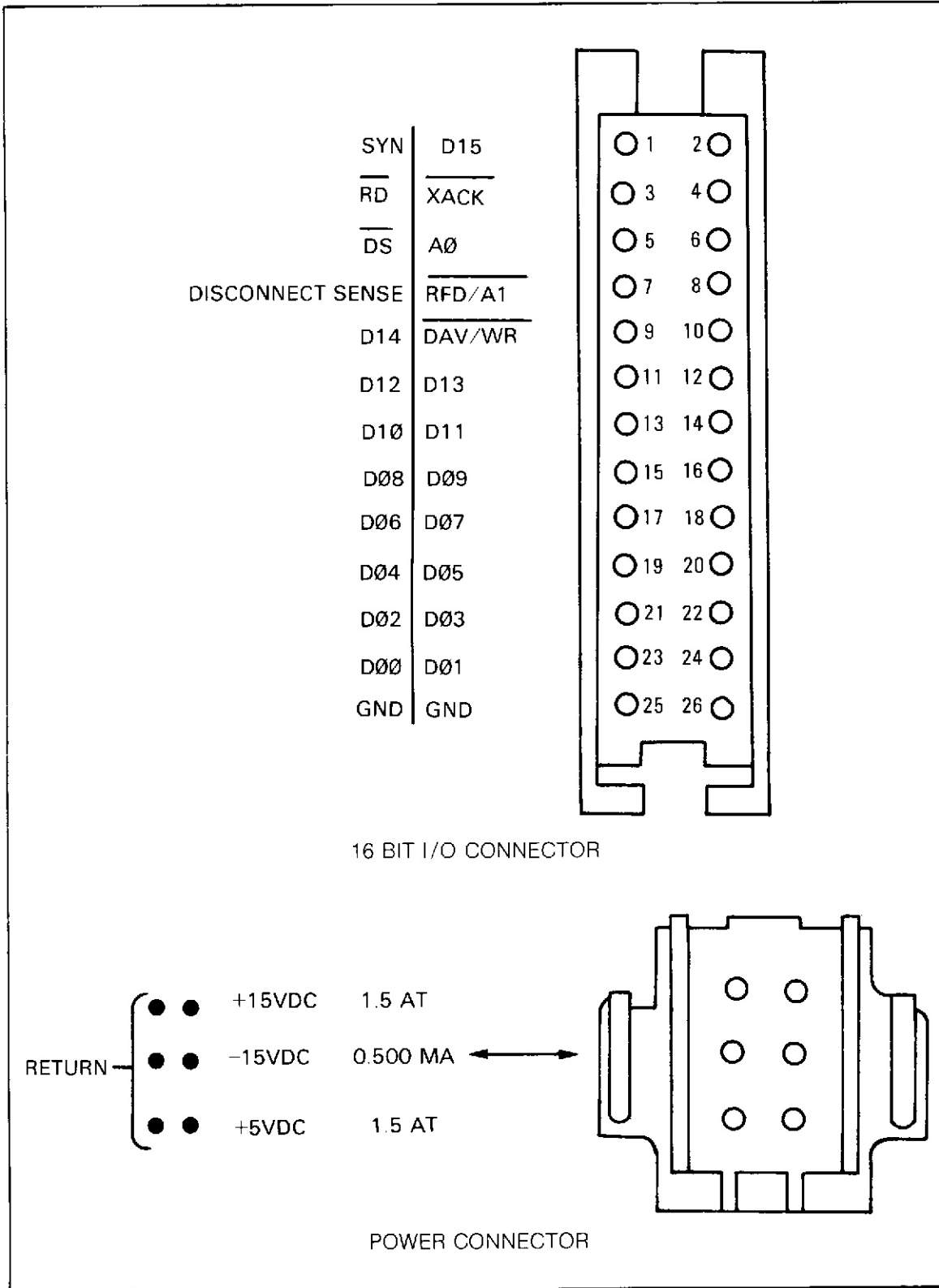

Figure 4-4. 1345A Rear Panel Connectors

The transfer of data to the 1345A is alternately controlled by both the user instrument and the 1345A. The 1345A controls the maximum speed of the data transfer with the \overline{RFD} signal line. The user processor signals the availability of new data by the state of the \overline{DAV} signal line. To correctly transfer data, the 1345A and the user processor must execute the two wire handshake sequence shown in figure 4-5.

1345A Handshake Sequence.

\overline{RFD} — Initiated by the 1345A. The 1345A will set this line to a low TTL level when the 1345A is Ready For Data.

\overline{DAV} — Initiated by the user processor. The user processor should set this line to a low TTL state when the data on the 16 bit data bus is valid.

There are 4 important steps in the handshake sequence. These are detailed below.

1. The 1345A will set \overline{RFD} low to indicate that it is ready to accept data. \overline{DAV} must initially be in a high state. If \overline{DAV} is not high the 1345A will NOT set \overline{RFD} low.
2. The user processor will set \overline{DAV} low when data on the 1345A data bus is valid. \overline{RFD} must be low prior to \overline{DAV} being set low.
3. The 1345A will set \overline{RFD} to a high TTL level to indicate acceptance of the data.
4. The user processor will return \overline{DAV} to a high state, allowing the 1345A to set \overline{RFD} low again.

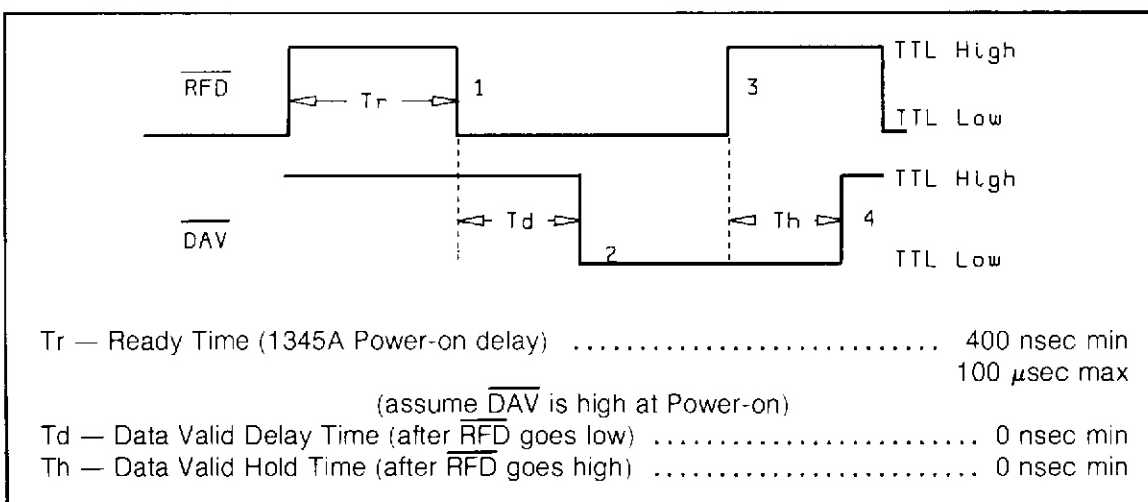

Figure 4-5. \overline{RFD} and \overline{DAV} Handshake Sequence and Timing

Restrictions.

1. The user processor can set \overline{DAV} low at the same time or after the 1345A sets \overline{RFD} low, but NOT BEFORE.
2. The user processor may return \overline{DAV} high at the same time or after \overline{RFD} is returned high, but NOT BEFORE.
3. The 1345A will NOT set \overline{RFD} low while \overline{DAV} is low.
4. Data on the 1345A 16 bit data bus MUST remain valid as long as \overline{DAV} is low. \overline{DAV} should remain low until \overline{RFD} is pulled high indicating data acceptance by the 1345A.

1345A Interface Example. The following circuit schematic was generated to illustrate the 1345A handshake processes. The circuit is used to interface a microprocessor CPU, a dual port memory, and the 1345A digital display. The use of a dual port memory allows the user CPU and the 1345A to share a common display memory. Either the CPU or the display refresh circuitry will have access to the display memory. The example circuit in figure 4-6 was designed to handle the memory access arbitration between the CPU and the 1345A interface refresh circuitry. It should be noted that this circuit contains only the arbitration and handshake circuitry.

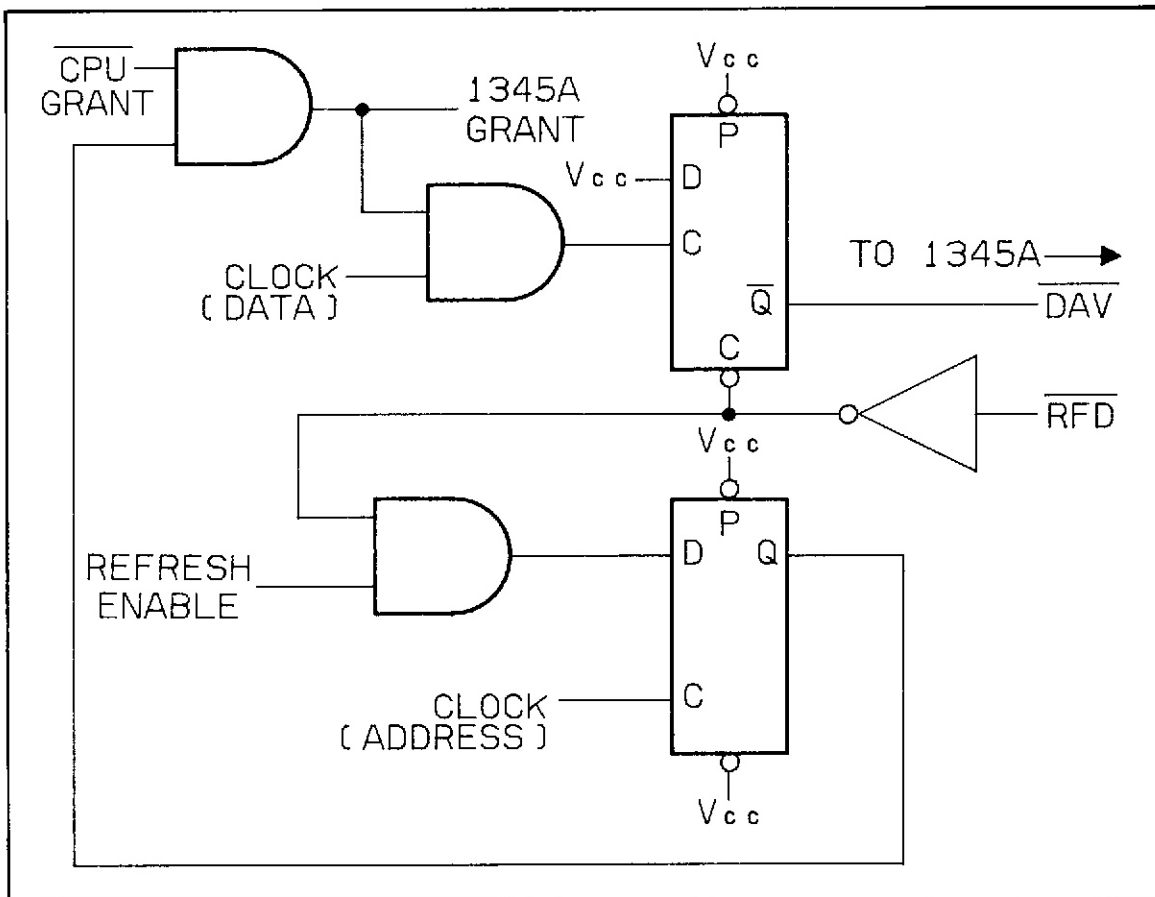

Figure 4-6. Example Dual Port Memory Handshake Circuit

The associated timing diagram was generated to demonstrate the arbitration and handshake process. The interface circuit uses the signals CPU grant and Refresh Enable to control the arbitration process. While CPU grant is low the user CPU has access to the dual port memory. When this signal is returned to an inactive high state, the handshake process resumes as shown in traces 0, 1, and 2 of figure 4-7. While CPU grant and Refresh Enable are high, 1345A grant is high, and the refresh circuitry is enabled. When enabled, the refresh circuitry sequences through the display memory and sends the vector data to the 1345A. Trace 3 is the Refresh Enable signal line, which is high indicating a pending refresh request. This signal is generated by an interface timer circuit approximately once every 16.6 ms. This signal is latched and input to the handshake circuit as the Refresh Enable signal. The two clock signals are used to clock data transfers and memory access arbitration. User interface configurations may require different clocking techniques for correct operation. This interface circuit is intended to be used as a guideline by the user when designing a 1345A display interface.

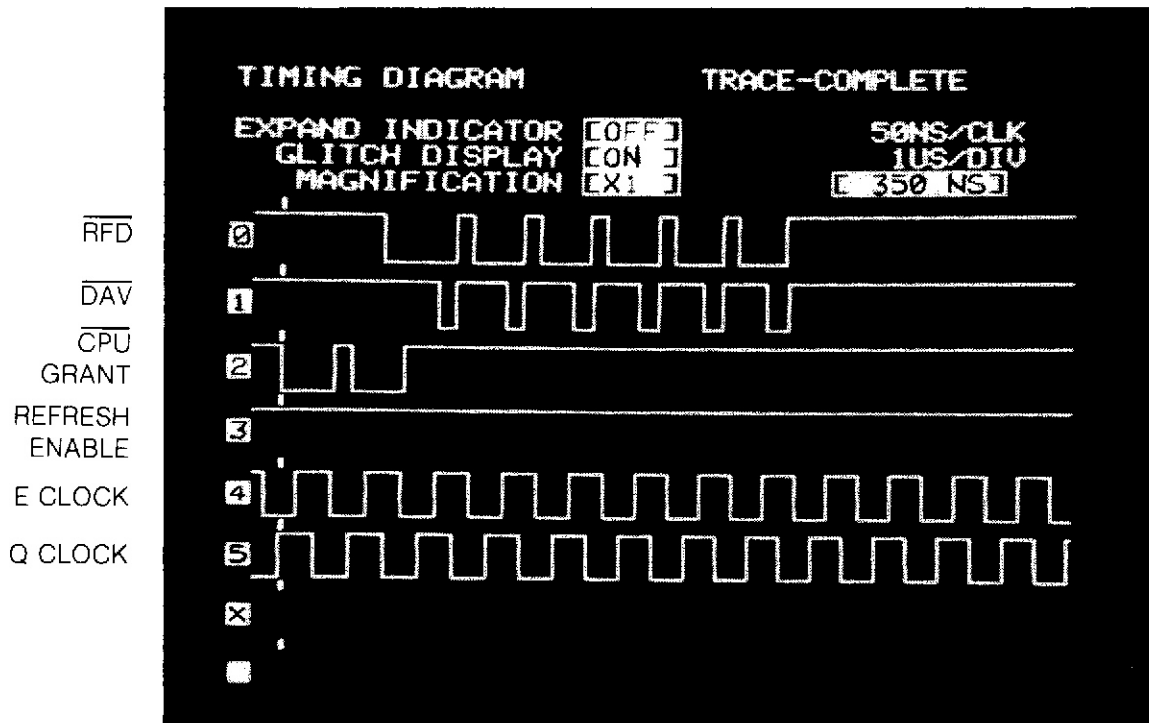

Figure 4-7. 1615A Timing Analyzer Diagram Of Example Circuit Handshake

HANDSHAKING WITH THE MEMORY OPTION (OPTION 704).

Handshake operation of a 1345A with the Memory Option installed requires use of different handshake signals. When the memory option is installed the signal lines \overline{RFD} and \overline{DAV} are not used. The signal lines used are \overline{DS} , \overline{RD} , \overline{WR} and A0.

- \overline{DS} — Device Select. The user interface sets this line low when addressing the 1345A with memory option installed.
- \overline{RD} — Read. When this line is set low the contents of the memory address indicated by the Vector Memory Address Pointer are placed on the 1345A 16 bit data bus for transmission to the user interface.
- \overline{WR} — Write. When low, this line indicates that the contents of the 1345A 16 bit data bus are to be written into either the current Vector Memory address location or into Vector Memory address pointer.
- A0 — Vector Data Enable line. This signal is active only when \overline{WR} is a TTL low. If A0 is high, the data on the 16 bit I/O is written into vector memory. When A0 is low the data is written into the vector memory address pointer.
- A1 — unused.

NOTE: The signals \overline{RD} , \overline{WR} , A0 are active ONLY while \overline{DS} is low.

There are two Vector Memory signal lines that may be used for control purposes. Their use is optional. These signals are SYNC and \overline{XACK} .

- SYNC — External Refresh Synchronization. A positive going TTL edge on this signal line will activate a display refresh cycle. This optional signal is enabled via a jumper wire on the memory option board. If not used, refresh is internal. The factory setting is for internal sync.
- \overline{XACK} — Transfer Acknowledge. When low, this line indicates that the memory has completed a READ or WRITE operation. Since the cycle time of the memory is less than 565 ns, the user need not use this line if the data transfer rate is less than 1.77 mhz.

The Handshake Timing diagrams in figure 4-8 and 4-9 contain the Read and Write timing relationships of the memory option board. For a complete description of memory board operation, refer to section V of this manual. An installation and configuration procedure for the Memory Option is contained in appendix C of this manual.

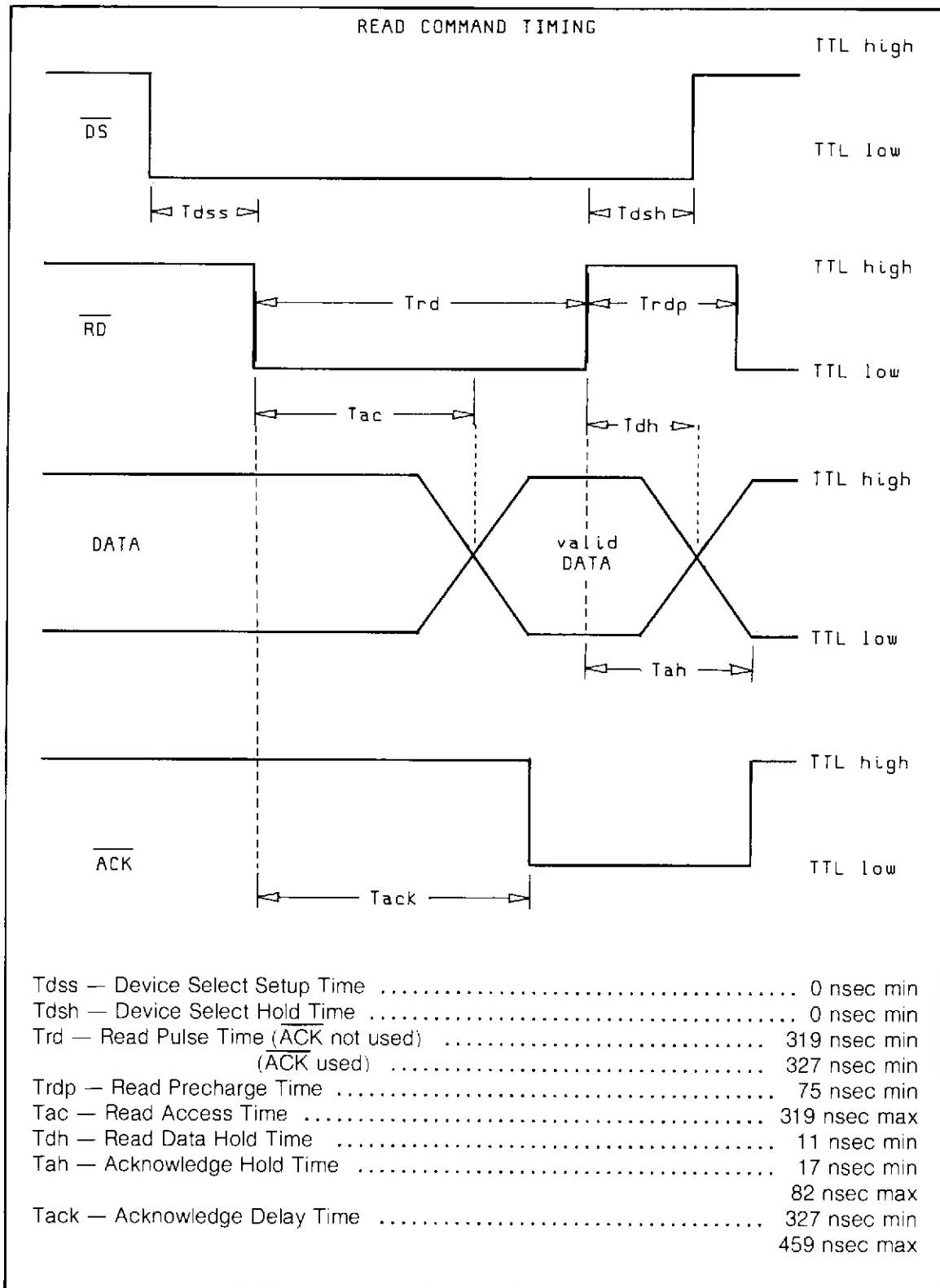

Figure 4-8. Memory Read Timing

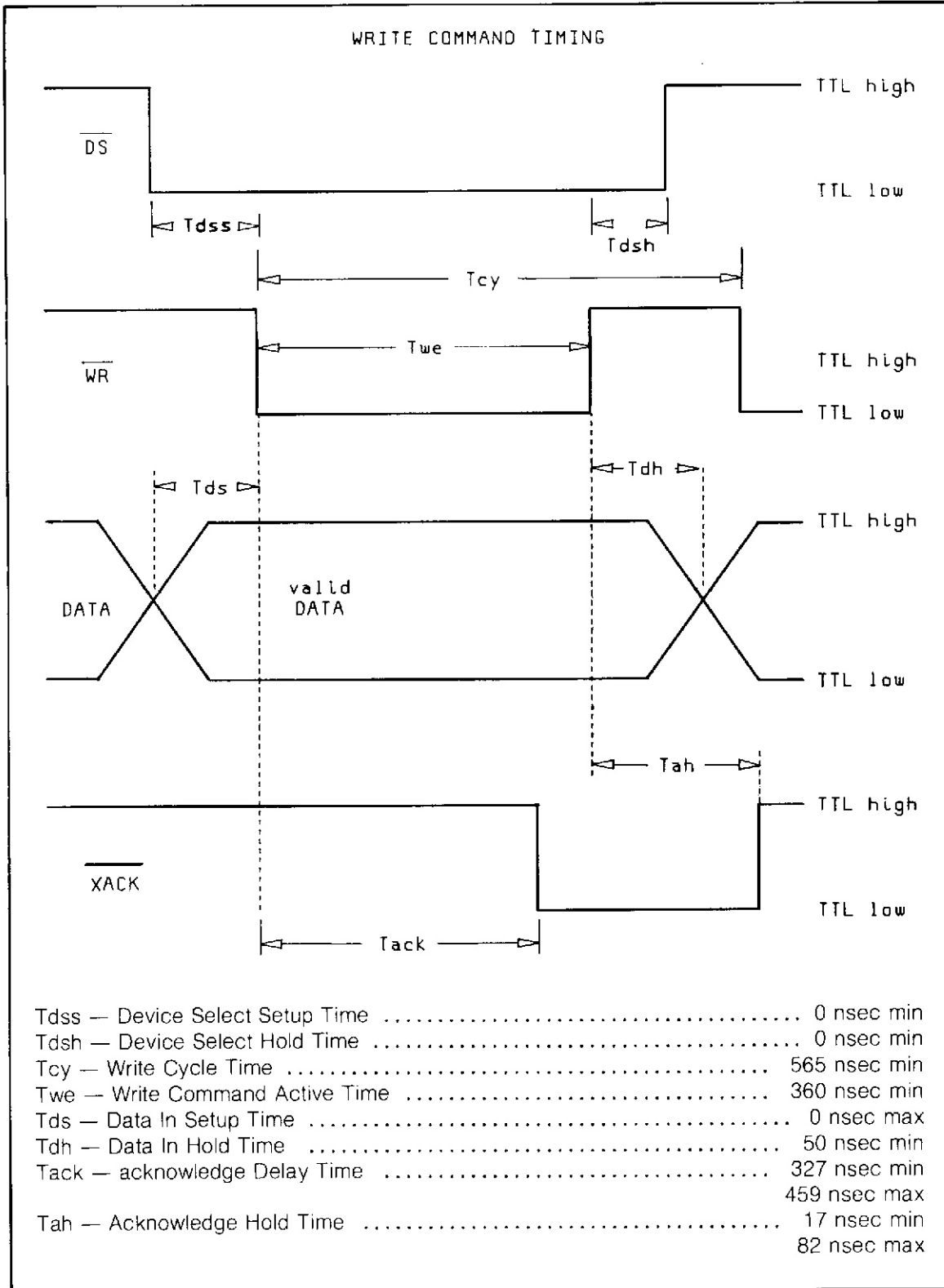

Figure 4-9. Memory Write Timing

Example Vector Memory Interface. Interfacing the 1345A with the optional memory is easier than interfacing to the standard 1345A. The Vector Memory appears to the user processor as a memory location. The user processor simply writes to or reads from a memory location in the available address space and interface circuitry generates the required handshake signals. The interface circuit in figure 4-10 can be used to interface to the optional Vector Memory. The contents of the address bus are decoded into an interface function. The output of this block is either a Device Select or a Read signal. The direction of the data transfer is controlled by the Read/Write signal line of the user processor. The timing for the data transfers must follow the specifications in figure 4-8 and 4-9. The transfers are enabled by the user processor by either reading or writing to an addressable memory location. The address decoding circuitry will decode this address and generate the required signals to insure a correct data transfer. For complete vector memory programming information, refer to section V of this manual.

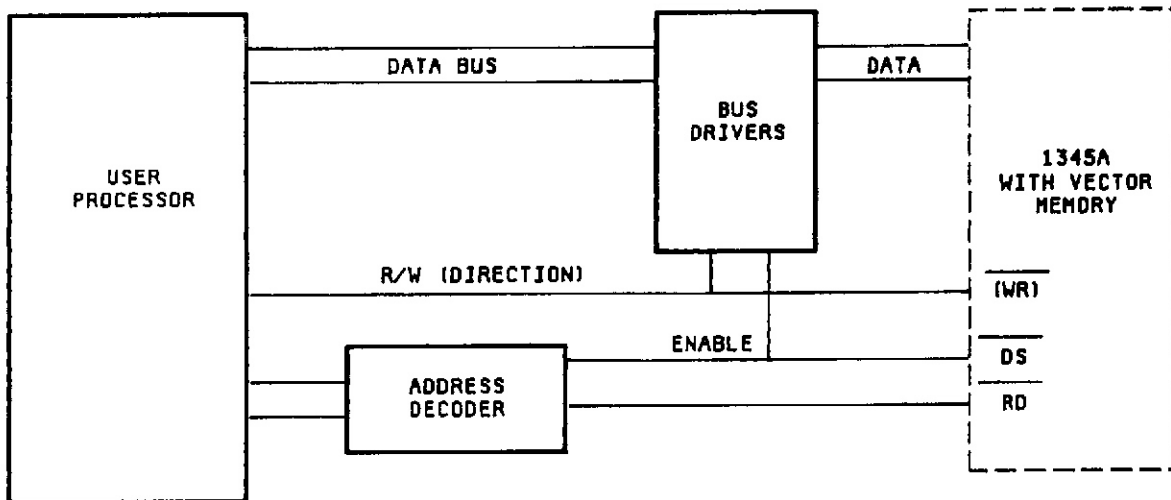

Figure 4-10. Example Vector Memory Interface

1345A Signal Line Characteristics.

An important topic to be discussed is that of interface signal line characteristics. The functional aspects of these signal lines have been presented. The electrical characteristics are important for correct operation of the 1345A.

The 1345A Digital Display has a 26 pin connector that is used as the data interface connector. The pin numbers and identification numbers are shown in figure 4-4. These signals are defined for data, handshake and the vector memory option. The electrical characteristics are important for use with an interface for loading considerations. The following signal line characteristics are typical of the 1345A with and without the memory option. Table 4-1 contains a list of signal line characteristics for a standard 1345A, while table 4-2 contains characteristics of the 1345A signal lines with the memory option installed.

Table 4-1. Signal Line Characteristics of the 1345A

V _{IH} High Level Input Voltage	5.0 V _{max} 2.0 V _{min}
V _{IL} Low Level Input Voltage	0.8 V _{max}
I _{IH} High Level Input Current	~ 85.0 μa @ 2.7 Volts
I _{IL} Low Level Input Current	~ -1.6 ma @ 0.4 Volts

Table 4-2. Signal Line Characteristics of the 1345A With Memory Option Installed

V _{IH} High Level Input Voltage	5.0 V _{max} 2.0 V _{min}				
V _{IL} Low Level Input Voltage	0.8 V _{max}				
Memory Board Inputs.					
	<table border="0"> <tr> <td style="text-align: center;">I_{IL} (max)</td> <td style="text-align: center;">I_{IH} (max)</td> </tr> <tr> <td style="text-align: center;">Low level Input Current</td> <td style="text-align: center;">High Level Input Current</td> </tr> </table>	I_{IL} (max)	I_{IH} (max)	Low level Input Current	High Level Input Current
I_{IL} (max)	I_{IH} (max)				
Low level Input Current	High Level Input Current				
D0-D15	-0.2 ma 20 μa				
DS*	-6.9 ma 70 μa				
WR*	-6.5 ma 50 μa				
RD*	-4.9 ma 20 μa				
SYNC*	-5.3 ma 40 μa				
A0	-2.2 ma 60 μa				
*NOTE: This signal line has a 1k pull up resistor to +5 volts in 1345A.					
Memory Board Outputs.					
D0-D15†	<table border="0"> <tr> <td style="text-align: left;">VOL Low Level Output Voltage</td> <td style="text-align: right;">0.5 Volts @ IOL = 24 ma</td> </tr> <tr> <td style="text-align: left;">VOH High Level Output Voltage</td> <td style="text-align: right;">2.0 Volts @ IOH = -15 ma</td> </tr> </table>	VOL Low Level Output Voltage	0.5 Volts @ IOL = 24 ma	VOH High Level Output Voltage	2.0 Volts @ IOH = -15 ma
VOL Low Level Output Voltage	0.5 Volts @ IOL = 24 ma				
VOH High Level Output Voltage	2.0 Volts @ IOH = -15 ma				
XACK†	<table border="0"> <tr> <td style="text-align: left;">VOL Low Level Output Voltage</td> <td style="text-align: right;">0.5 Volts @ IOL = 24 ma</td> </tr> <tr> <td style="text-align: left;">VOH High Level Output Voltage</td> <td style="text-align: right;">2.4 Volts @ IOH = -2.6 ma</td> </tr> </table>	VOL Low Level Output Voltage	0.5 Volts @ IOL = 24 ma	VOH High Level Output Voltage	2.4 Volts @ IOH = -2.6 ma
VOL Low Level Output Voltage	0.5 Volts @ IOL = 24 ma				
VOH High Level Output Voltage	2.4 Volts @ IOH = -2.6 ma				
†NOTE: These signal lines have tri-state outputs.					

Crosstalk.

An important consideration in digital signal transmission is crosstalk between signal lines. Proper use of the 1345A two wire handshake will minimize the possibility of crosstalk during data transmission. Correct use of the signal line $\overline{\text{DAV}}$ is particularly important in avoiding difficulties due to crosstalk. The handshake timing example in figure 4-7 illustrates the proper use of the $\overline{\text{DAV}}$ handshake line. Another consideration is that of signal line length. The recommended maximum length is 2 feet. It is recommended that the I/O cable be kept as short as possible. By using the correct handshake sequence and keeping signal lines as short as possible, the potential of crosstalk can be kept to a minimum.

Test Pattern Generation.

One additional signal not previously discussed is the "Disconnect Sense" line. This line is active low, and is used to determine if the 1345A is connected to a controller. The user interface MUST keep this line low when the 1345A is in use. If this line is allowed to go to a high state the 1345A will try to display its internal test and calibration pattern on the CRT screen. Undefined conditions will result if the other signal lines are not either disconnected or tri-stated when "Disconnect Sense" is disconnected, pulled high or tri-stated. The internal test and calibration pattern may be properly initiated by tri-stating all other signal lines and pulling disconnect sense high from the user interface. The test pattern is used to verify correct operation of the 1345A without the use of an external controller by disconnecting the rear panel data cable and applying power to the 1345A. If the 1345A is functioning properly, the test and calibration pattern should appear on the display. Figure 4-11 shows a valid test and calibration pattern. The internal self test will also test the memory option if installed. If the memory is defective the 1345A will appear as in figure 4-12. If the 1345A is not calibrated or is not operating correctly, contact your local Hewlett-Packard authorized sales and service office.

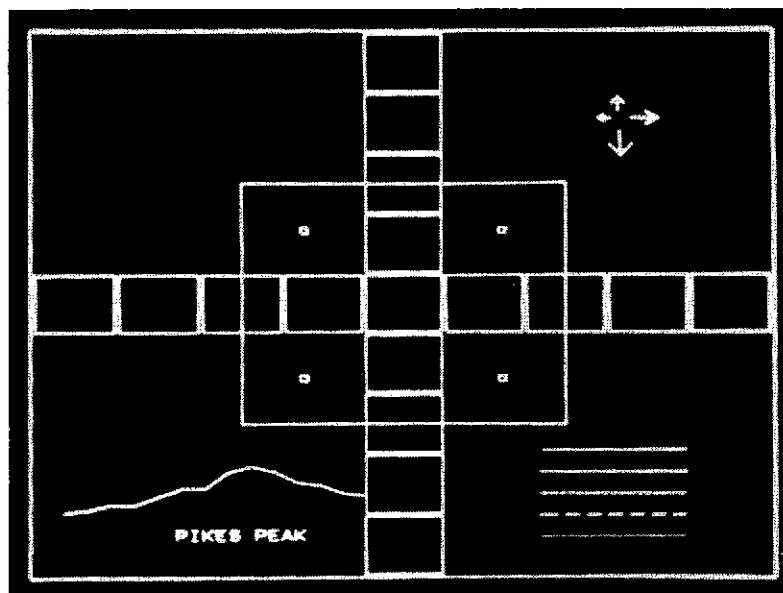

Figure 4-11. Correct Test Pattern

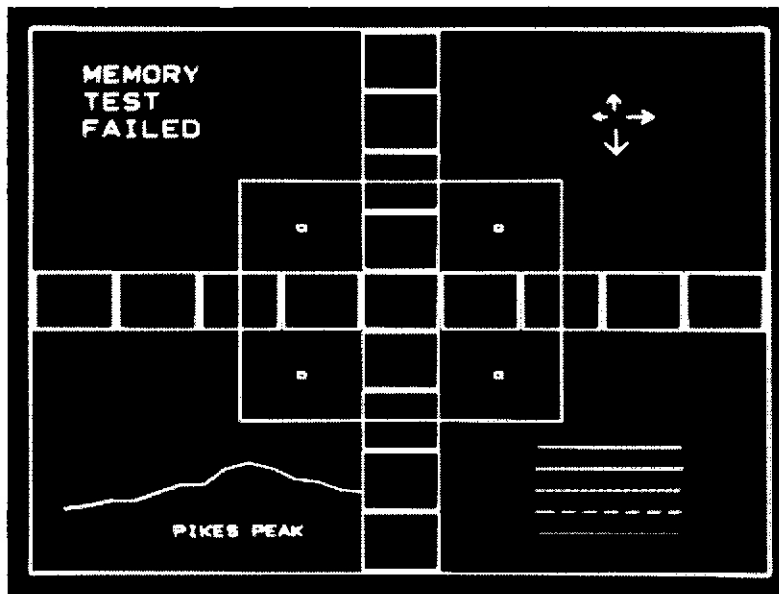

Figure 4-12. Test Pattern With Defective Memory

1345A DIGITAL DISPLAY IMPLEMENTATION.

The choice of user system microprocessor and complexity of the user interface depends on the capabilities required of the user instrument and the other tasks the microprocessor must perform. We will discuss three basic types of display interface techniques, as illustrated in figure 4-13. When interfacing to the 1345A to a user instrument, one of these three basic interfaces will probably be used. Each type of interface will be discussed highlighting advantages, disadvantages and typical applications were each type of interface might be used.

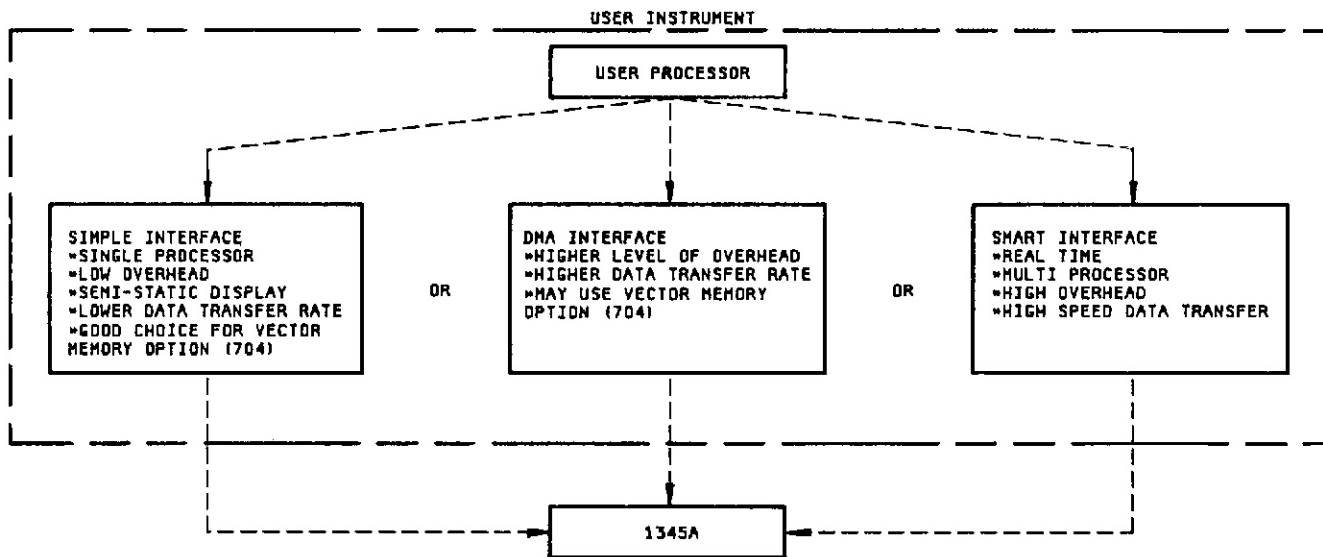

Figure 4-13. 1345A Interfacing Techniques

Simple Interface.

The simplest type of interface that can be constructed for the 1345A is a single microprocessor system. In this type of system the interface is part of the microprocessor address space and the entire instrument is controlled by a single processor. Typical application characteristics for this type of interface are low system overhead, semi static display, and slower data transfer rate. This would be a good type of interface for an instrument that displays linear data thus utilizing the graph mode of the 1345A. In graph mode, less vectors are required to create linear displays. A block diagram of a typical single processor interface is contained in figure 4-14.

The vector memory board would be a good choice for this type of interface. If the memory option is not used, the number of vectors that can be displayed is limited by the amount of time the user processor has to update the display. Typically this will be only a few hundred vectors. If the memory option is used, display data is stored in the vector memory which will handle the display refresh requirements. The number of vectors that can be displayed is limited by the total vector length capabilities of the 1345A. Use of the memory option board in this situation will enhance the overall system performance.

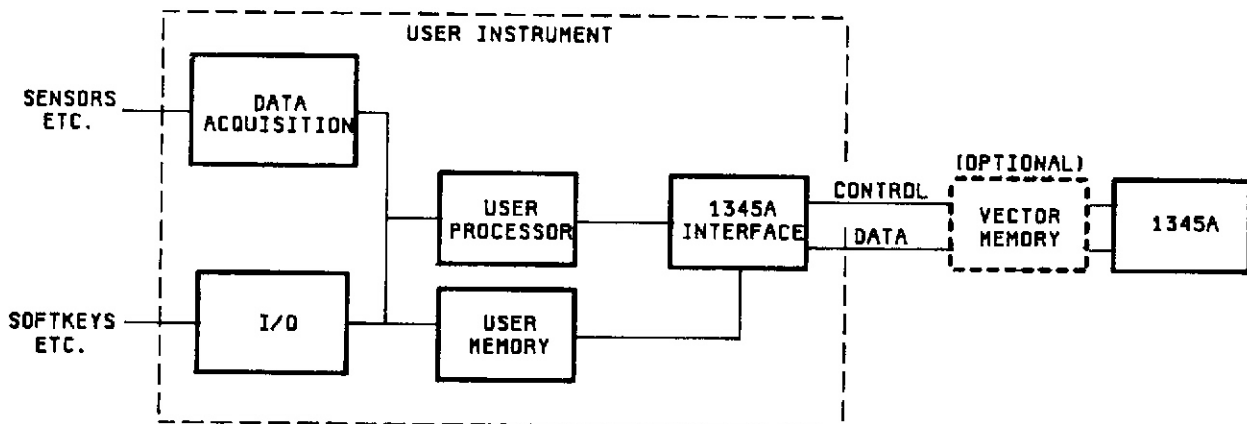

Figure 4-14. Single Processor Interface

DMA Interfaces.

A DMA interface allows the transfer of data to the 1345A to occur without using up user processor time. This type of interface requires the user processor set up the transfer but not control it. The DMA circuitry on the interface will control the transfer. This allows the user processor to start a data transfer and then go process other tasks such as keyboard scanning, data acquisition, etc. A system that does all these functions needs to have a data transfer technique that leaves the user processor free to perform these other functions. The method in this case is DMA with or without Optional Vector Memory. It is possible for the user instrument to make use of both a DMA interface and the vector memory. In this case the user processor would initiate a DMA transfer to the memory. The memory would then handle all refresh requirements independent of the user processor. The only display overhead would be when the user processor needs to send new data to the 1345A. The entire 4096 locations of the vector memory can be written in less than 3 ms. The user interface could hold off one 16.6 ms refresh cycle and rewrite the new data into the memory. If the optional Vector Memory is not used, the user interface must have access to a selected area of memory set aside for display data and a timer that schedules refresh cycles. When a DMA request is activated, the user interface will access the display memory and write this data to the 1345A without user processor intervention. An example DMA interface is illustrated in the block diagram in figure 4-15. The advantages of this type of interface are low overhead to the user processor and faster data transfer rates. The disadvantage is that the interface is harder to construct and configure into a processor system than the simple interface. Typical applications for this type of interface are interactive systems with dynamic displays of continuous data acquisition.

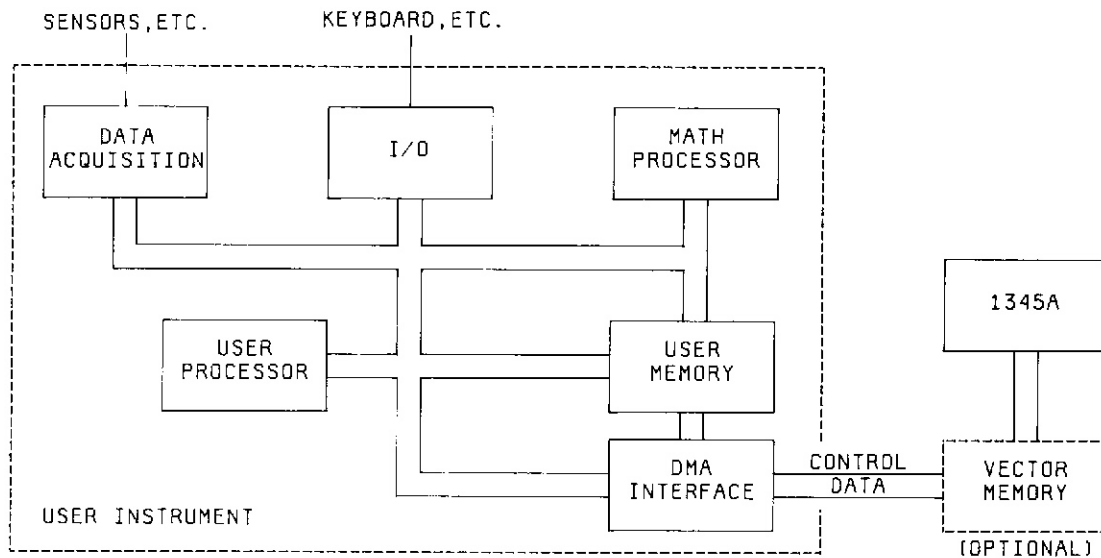

Figure 4-15. Typical DMA Interface

Smart Interface.

This type of interface is intended for the user who requires maximum display performance. An interface of this variety is custom designed to maximize data transfer from the user instrument input to display output. These type of instruments are usually driven by several microprocessors, each having a limited number of tasks. A typical 1345A interface for this type of instrument would contain smart hardware or a dedicated microprocessor. This interface would control refresh timing and data transfer to the 1345A. The user processor in the instrument would not need to handle any data transfer tasks. It would be advantageous to the user to have the interface utilize a high speed dual port memory to minimize data transfers. Figure 4-16 contains a block diagram of this type of interface. A typical application for this type of interface would be a Real Time measurement instrument. Typically the data to be displayed is totally different each refresh cycle. The obvious advantage of this type of interface is speed. It is however, much more difficult to implement. The memory board would probably not be a good choice for this type of system.

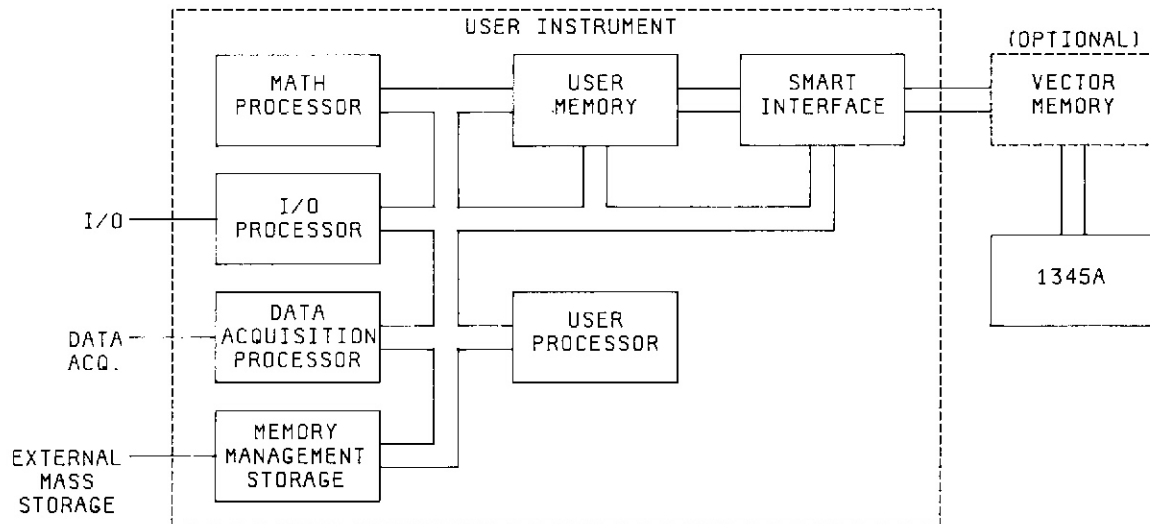

Figure 4-16. Example Smart Interface

SECTION V

1345A PROGRAMMING

INTRODUCTION.

This section of the DESIGNERS MANUAL will describe the programmable functions of the 1345A Digital Display Module. Proper understanding of the capabilities and limitations of the 1345A will enable the user to obtain optimum performance. This section of the manual will be divided into three parts. These three parts will address the areas of 1345A Programming Commands, 1345A Display Requirements, and Performance Optimization. It is recommended that the user read through Section 4, Interfacing the 1345A, prior to reading this section. Please read the complete text once to gain a firm foundation of the total 1345A operating environment.

The 1345A Digital Display has 4 commands. These are PLOT, GRAPH, SET CONDITION, and TEXT. These four commands provide complete programmable vector and text generation with a minimum of command overhead. Most vector and text operations can be handled with only one 16 bit command word.

The 1345A receives 16 bit data words over the 26 pin interface connector. These 16 bit data words are decoded by the 1345A into one of four distinct commands. Each 16 bit data word sent to the 1345A can be separated into two distinct data fields. The 1345A 16 bit data word is shown in figure 5-1.

Each of the commands that the 1345A can recognize is selected by the state of data bits D14 and D13. Data bit D15 is used only for memory board operations and is discussed later. The 1345A without memory uses only data bits D0-D14. The lower 13 data bits D0-D12 are used as command modifiers.

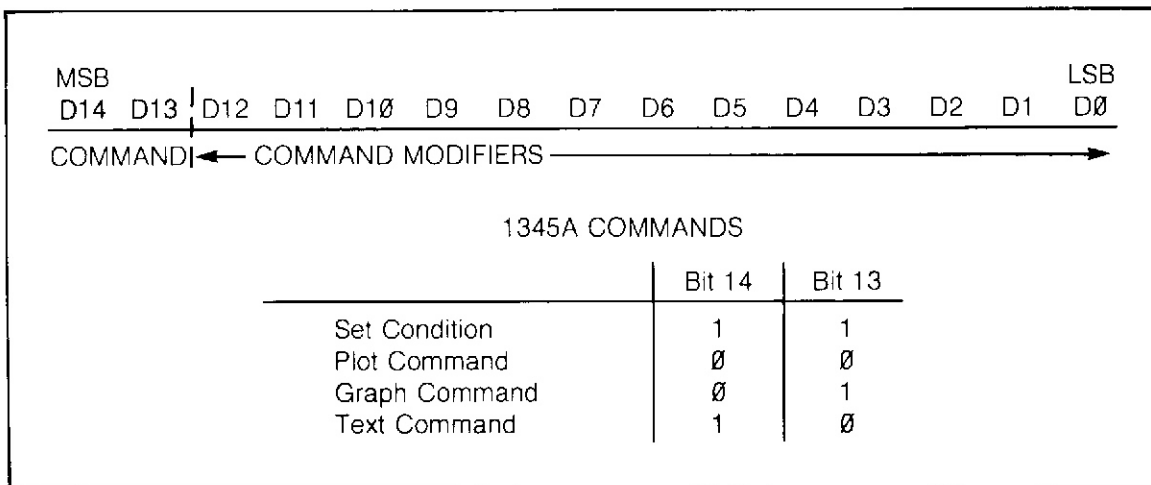

Figure 5-1. 1345A 16 Bit Data Word

These modifiers allow each command to have several selectable attributes. Vector drawing operations are directly dependent on the status of these data bits in every 1345A command. Each of these commands and their modifiers will be discussed using programming examples. The 16 bit data for the examples will be in HEXADECIMAL or HEX format. This format is easier to follow than 16 bit binary data words. Each HEX data word sent to the 1345A will be equivalent to a 16 bit binary word.

HEX Format Generation. Each 16 bit data word can be separated into four, four bit binary numbers. This allows each four bit binary number to have sixteen distinct combinations. Each of these combinations is assigned a HEX equivalence. The conversion from binary to HEX is contained in figure 5-2.

Each data word in the following command examples will use this HEX format. These HEX representations will correspond to the required bit patterns recognized by the 1345A.

Hexadecimal Code	Binary Code			
	b4	b3	b2	b1
0	0	0	0	0
1	0	0	0	1
2	0	0	1	0
3	0	0	1	1
4	0	1	0	0
5	0	1	0	1
6	0	1	1	0
7	0	1	1	1
8	1	0	0	0
9	1	0	0	1
A	1	0	1	0
B	1	0	1	1
C	1	1	0	0
D	1	1	0	1
E	1	1	1	0
F	1	1	1	1

Hex Code	C	F	0	8
Binary Code	1100	1111	0000	1000

Figure 5-2. Binary to HEX Conversion

PROGRAMMING EXAMPLES.

Vector Plotting.

An explanation of vector drawing will help clarify the process. In figure 5-3, there are three vectors defined by four endpoints. Each vector requires two endpoints. The vector from point 1 to point 2 requires two endpoint declarations. The vector from point 2 to point 3 requires only point 3 be declared as an endpoint, because point 2 is already established. The vector drawn from point 2 to point 3 is a vector with the beam off. This allows the beam to be moved to new vector starting points without affecting existing displayed vectors. The vector from point 3 to point 4 is drawn with the beam on. The

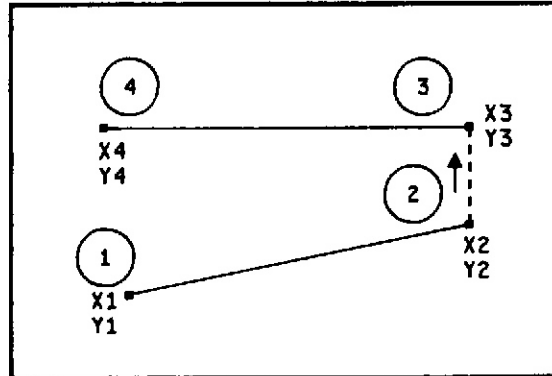

Figure 5-3. Vector Plotting

correct sequence for constructing vectors in PLOT mode is ALWAYS X first, Y next, X, Y, X, ..., Y, until the vector sequence is complete. A vector is plotted according to the last SET CONDITION command sent to the 1345A.

The "BEAM ON" bit in the PLOT command is ignored if the coordinate being specified is an X value. The beam status only has effect if the Y coordinate is being entered. The CRT beam will move to the location specified by the last X and Y coordinate values specified in the PLOT commands.

Graph Plotting.

An example of the graph command is contained in figure 5-4. In this example 15 vectors are drawn with only 20 commands. The sequence is described below.

- Step 1 — Set Condition to define line type.
- Step 2 — Plot command to set X location at lower left corner of graph.
- Step 3 — Plot command to set Y location at lower left corner of graph.
- Step 4 — Graph command to set X increment value. This value is referenced to the X axis of the graph.
- Step 5 — Graph command with beam off and Y value set to 0. This will not plot anything, but is used to initiate the X increment to point 1.
- Step 6 — Graph command with beam on and Y value set to point 1.
- Step 7 — Graph command with beam on and Y value set to point 2.
- ...
- ... (send only Y values of points 3 through 14)
- ...
- Step 20 — Graph command with beam on and Y value set to point 15.

Normal X,Y plot mode would require 33 commands to construct the same graph. Note that the above command sequence does not include generation of the graph axis, only construction of the graph itself.

The construction of a graph can have two forms. The vectors may start at either the origin or somewhere along the Y axis of the graph. If the origin is the starting point, then the user needs to set the first Y value to zero. This will not plot anything but will start the graph at the origin and increment the X value by one. When the next Y value is sent, a vector will be drawn from the origin to the new Y value. If the Y axis is the starting point then the user needs to send the first Y value with the beam off. This will insure that the axis of the graph is not altered by the line type set for the graph trace. For the next Y value the beam should be turned on.

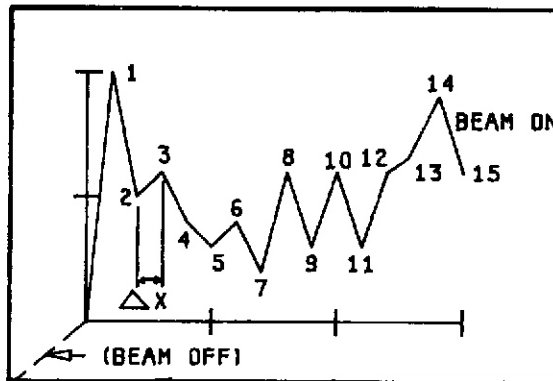

Figure 5-4. Graph Mode Example

1345A COMMANDS.

Set Condition Command.

When D14 and D13 are both in the High TTL state, the 1345A will interpret the data word as a SET CONDITION command. This command is used to set vector attributes. The attributes affected are line type, speed, and intensity. The required bit patterns for this command and its command modifiers are contained in figure 5-5.

By combining line intensity and writing speed parameters, up to twelve levels of discernible intensities can be generated. Figure 5-6 contains several example combinations. This allows the user to create displays with background graticules and intensify important trace data. The beam will be brightest with the intensity set at full bright at the slowest writing speed. The beam will be dimmest with the intensity set at dim at the fastest writing speed. The SET CONDITION command may be executed at any time and the vector attributes will remain in effect until another SET CONDITION command is executed. Data bit 6 in this command is defined to be TTL low. This MUST occur when the Set Condition command is executed or the display may respond in an undefined fashion.

Set Condition Command:

MSB											LSB			
D14	D13	D12	D11	D10	D9	D8	D7	D6	D5	D4	D3	D2	D1	D0
1	1	I ₁	I ₀	X	X	L ₁	L ₀	0	X	W ₁	W ₀	X	X	X

Note: Bit 6 (D6) must be zero.

Command Modifiers:

a. To Set Line Intensity:

I ₁	I ₀	Intensity
0	0	Blank
0	1	Dim
1	0	Half Brightness
1	1	Full Brightness

b. To Set Line Type:

L ₁	L ₀	Type
0	0	Solid Line
0	1	Intensified End Points on Solid Line
1	0	Long Dashes
1	1	Short Dashes

c. To Set Writing Speed:

W ₁	W ₀	Speed
1	1	0.05 in. per μ s
1	0	0.10 in. per μ s
0	1	0.15 in. per μ s
0	0	0.20 in. per μ s

Figure 5-5. Set Condition Command

6998 _h	Dim. Short Dash, Speed 0.05
7800 _h	Bright, Solid, Speed 0.2
7000 _h	Half Bright, Solid, Speed 0.2
7100 _h	Half Bright, Long Dash, Speed 0.2

Figure 5-6. Set Condition Examples In Hex

Plot Command.

When the two most significant bits of the data word, D14 and D13 are in a low TTL state, the 1345A will recognize the data word to be a PLOT command. Figure 5-7 contains the correct bit pattern for this command.

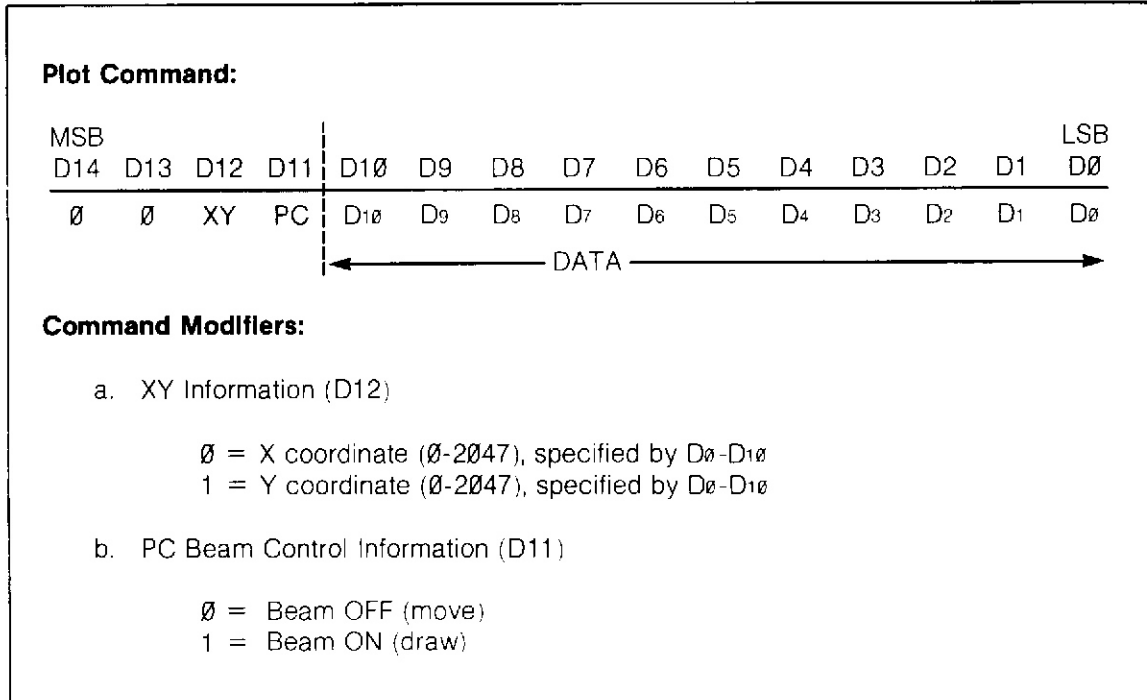

Figure 5-7. Plot Command Bit Pattern

This command moves the beam to a specific X-Y location in the defined cartesian coordinate plane each time an X-Y coordinate pair is received. The values of the X and Y coordinates range from 0 to 2047. The origin of the cartesian plane is located in the lower left corner and has an X-Y value of (0,0). This command also turns the beam on or off for each vector. The beam may be moved in either mode. The vector is drawn from the previous beam location to the current location specified by the last two X,Y coordinate values in the PLOT commands. The vector is drawn in accordance with the last SET CONDITION command received by the 1345A.

The diagram in figure 5-8 is a single vector defined by its endpoints in the vector drawing area. To draw this line the 1345A would need to receive two sets of X and Y coordinates. The 1345A receives the coordinates in the specified order X1,Y1,X2,Y2. The beam is moved only when the Y coordinate is received. The status of the beam is only affected by the beam status bit in the Y coordinate command.

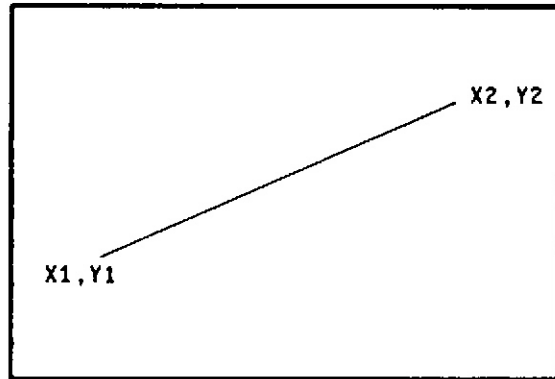

Figure 5-8. Vector Defined By Endpoints

An example of vector plotting is contained in figure 5-9. This example contains vectors drawn with the beam on and with the beam off. The steps to draw these figures are given in the required sequence with equivalent HEX code for the 16 bit data words.

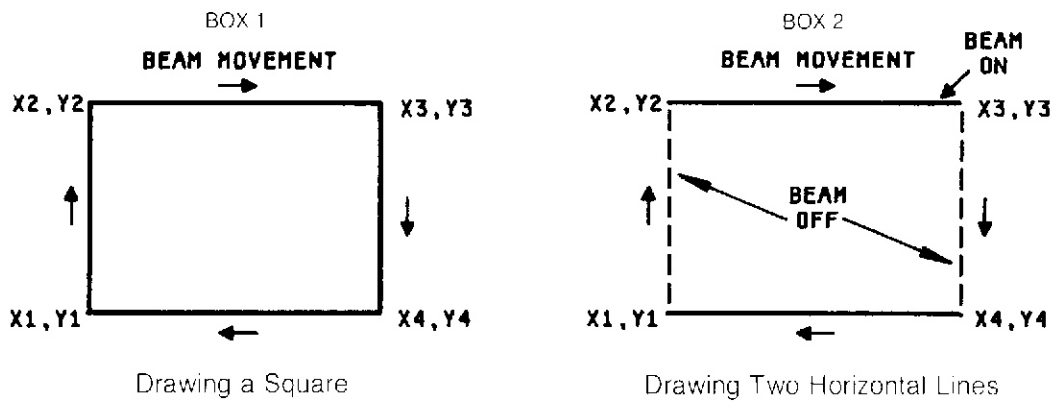

Figure 5-9. Plot Vector Example

To draw the figures, send the following 16 bit data words in sequence to the 1345A.

Command Step	Box 1 data	Box 2 data	1345A
1. Set Condition	7818h	7818h	Sets Vector type (Solid Full Bright, 05)
2. Plot X1	0200h	0200h	X1=512
3. Plot Y1 (beam off)	1200h	1200h	move to Y1=512
4. PLOt Y2 (beam on)	1F00h	(beam off) 1700h	move to Y2=1792
5. Plot X3	8F00h	8F00h	X3=1792
6. Plot Y3 (beam on)	1F00h	1F00h	move to Y3=1792
7. Plot Y4 (beam on)	1A00h	(beam off) 1200h	move to Y4=512
8. Plot X1	0200h	0200h	X1=512
9. Plot Y1 (beam on)	1A00h	1A00h	move to Y1=512

A description of these two examples will help the user understand the vector plotting process. Step 1 defines the vector attributes for the vectors to be plotted by the 1345A. Definition of a starting point is crucial when plotting vectors. Steps 2 and 3 initialize the starting point of the box. Next a new Y value is received indicating that the beam be turned on. Since the X value didn't change, only a new Y value need be sent. The beam will move to the location specified by the X-Y location when the Y value is received. The vector is drawn according to the status of the last SET CONDITION command.

When a new horizontal location is required, both the X and Y coordinates need to be sent to the 1345A. The beam is only moved and the vector drawn when a Y coordinate is received. The Y value doesn't change going from step 4 to step 5, but the X value does. This requires that a new X-Y coordinate pair be sent to the 1345A as in steps 5 and 6. In step 7, the X value doesn't require a change so only a new Y value is sent in step 7. The beam is turned on to draw the vector. In steps 8 and 9 a new X-Y pair is required so both values must be sent. To draw box 2, only steps 5 and 7 need to be changed. The beam status bit tells the 1345A to turn the beam off during the movement. A vector is still drawn, but with the beam turned off.

The user should notice that when a vector is to be drawn vertically, only a Y value is sent for the second vector endpoint. The 1345A has a "last X" register that stores the value of the last X location. This feature allows vertical vectors with the same X values to be drawn with one less endpoint requirement.

When plotting vectors in the vector drawing area, the user should take into account the difference in CRT screen height and width. The 1345A vector drawing area is 9.5 cm high by 12.5 cm wide and has 2048 addressable points in either direction. If this difference is not taken into account, boxes will appear as rectangles. To plot vectors correctly, the user may need to apply a scaling factor to vector endpoint calculations. The scaling factors for the 1345A are approximately 215.58 addressable points/cm in the Y direction and 163.84 addressable points/cm in the X direction. These figures are used when calculating the actual length of vectors in cm.

Graph Command.

The GRAPH command is very similar to the PLOT command. The purpose of the GRAPH command is to allow plotting of vectors that have equal incremental X coordinates. When data word bits D14 and D13 are TTL low and TTL high respectively the 1345A will interpret the data word to be a GRAPH command as shown in figure 5-10. In the GRAPH mode, the 1345A will automatically increment the X coordinate after each Y coordinate is received. This allows single valued functions to be plotted in graph form with fewer endpoints than would be possible using X,Y coordinates for each data point.

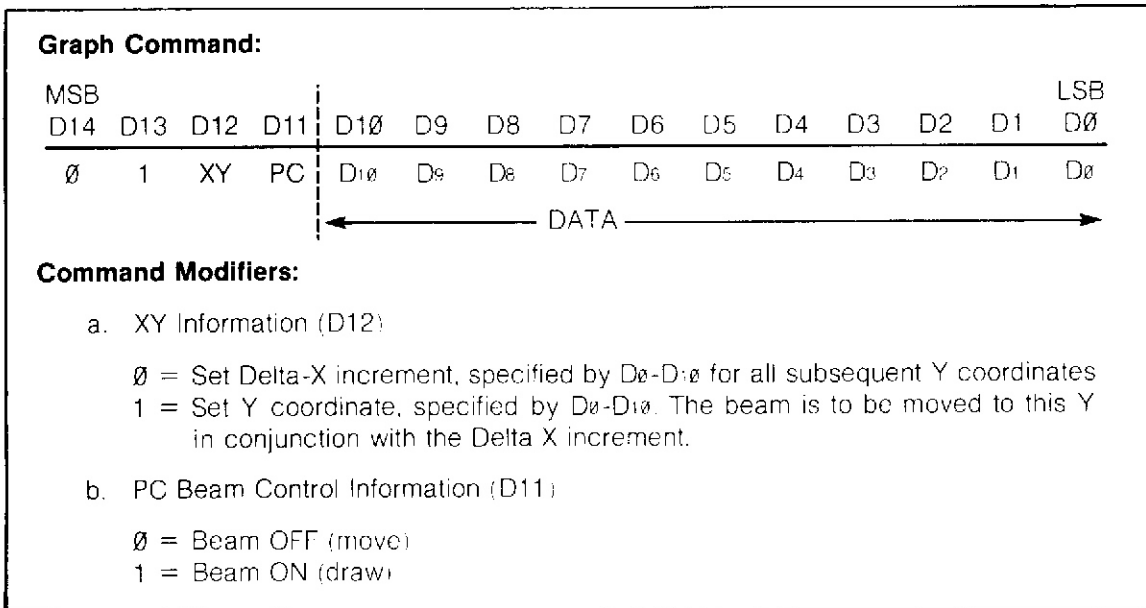

Figure 5-10. Bit Definition For Graph Command

There are three command modifiers in the GRAPH command. These modifiers control the X increment, Y coordinate data value, and the beam status. When D12 is 0, the data in bits D0-D10 define the value of the X increment. This is the amount the X coordinate will increase after each Y coordinate is plotted. The range of the X increment is 0 to 2047. It should be noted that X increases relative to present X,Y coordinate values on the screen. Figure 5-11 contains an example of the graph mode commands. The beam moves when the Y coordinate value is received.

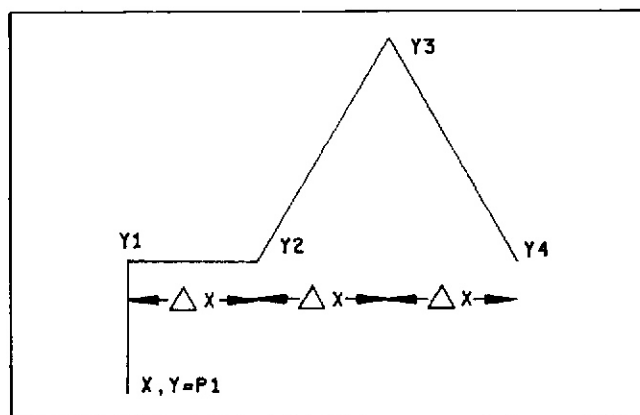

Figure 5-11. Graph Mode Example

To create the output in figure 5-10 the following steps were executed with the given 16 bit HEX data.

Command Step	16 Bit Data	1345A
1. Set Condition	7818h	Set Vector Attributes (Solid Full Bright, .05)
2. Plot X1	0200h	X=512
3. Plot Y1 (beam off)	1200h	move to Y=512
4. Graph command Set Delta X	2040h	set X increment to 64
5. Graph command Y1	3280h	Y=640
6. Graph command Y2	3280h	Y=640
7. Graph command Y3	3300h	Y=768
8. Graph command Y4	3280h	Y=640

Step 1 defines the line type, speed, and intensity. Steps 2 and 3 determine the starting point of the graph. The delta X increment is established in step 4. The (4) Y values are sent in steps 5-8. The value of X is incremented AFTER each Y value is received.

If the graph is to start at the axis origin, then execute a graph command with a first Y value set to zero. This will not plot anything, but will increment the X value by delta X. The next vector will be drawn from the origin to the Y value for the first X increment. If the graph is to start at the Y axis, then execute a Y value command. The next vector will be drawn from the Y value on the Y axis to the Y value of the first X increment.

Text.

The 1345A comes complete with an internal character generator. This internal character data is a modified ASCII character set for graphics use. The data for commanding the 1345A to enter the text mode is in figure 5-12. Data bits D14 must be TTL high and D13 must be TTL low. When this command is executed the 1345A will interpret the lower eight data bits, D0-D7 as an equivalence for an ASCII or special character. Each vector of the character is drawn on the CRT screen according to the vector characteristics of the last SET CONDITION command. The characters are always drawn at the slowest writing speed. The line type has no visible effect except on the largest character size, (2.5X). The position is defined by the last X and Y coordinates received by the 1345A.

When generating characters, the 1345A automatically provides character spacing to the right of each character. The TEXT command has command modifiers for size and rotation information. New size and rotation information is controlled by the status of data word bit D8. To initiate new character attributes, bit D8 must be set high as a new information indicator. If this data bit is "0", the size and rotation bits are ignored.

The 1345A has 4 character sizes. These 4 sizes are defined by the status of bits D11 and D12. The amount of space needed to draw the characters is contained in figure 5-12. This is the required space needed out of 2048 × 2048 possible points. The number of characters that can be drawn across the screen at the different sizes is in figure 5-13. An example of 1x character spacing is contained in figure 5-14.

Text Command:

MSB													LSB	
D14	D13	D12	D11	D10	D9	D8	D7	D6	D5	D4	D3	D2	D1	D0
1	0	S ₁	S ₀	R ₁	R ₀	ES	C ₇	C ₆	C ₅	C ₄	C ₃	C ₂	C ₁	C ₀

CHARACTER →

Command Modifiers:

For C₀-C₇, see figure 5-14

a. ES Establish Size of Character

0 = Use previous size and rotation

1 = Establish new size and rotation according to S₁, S₀, R₁ and R₀

b. Rotate Character CCW

R ₁	R ₀	Rotation
0	0	0 degrees
0	1	90 degrees
1	0	180 degrees
1	1	270 degrees

c. Character Size

S ₁	S ₀	Size	W × H (in addressable points)
0	0	1×	24 × 36
0	1	1.5×	36 × 54
1	0	2×	48 × 72
1	1	2.5×	60 × 90

Figure 5-12. Text Command Bit Pattern

4 PROGRAMMABLE CHARACTER SIZES:

1.0 × 56 characters per line, 29 horizontal lines possible.

1.5 × 37 characters per line, 19 horizontal lines possible.

2.0 × 28 characters per line, 14 horizontal lines possible.

2.5 × 22 characters per line, 11 horizontal lines possible.

Figure 5-13. 1345A Character Display Capabilities

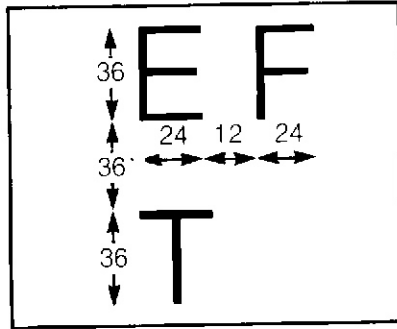

Figure 5-14. Example of 1x Character Spacing

The starting position of each character is the lower left corner of the defined character cell. After drawing a character, the 1345A advances to the starting point of the next character much like a typewriter would operate. The 1345A also contains many special characters that facilitate graphics and display annotation. Figure 5-15 contains the modified 1345A ASCII character set in HEX format. This HEX code is sent to the 1345A in the lower 8 bits of each text command.

1345A MODIFIED ASCII CODE CONVERSION TABLE									
		MOST SIGNIFICANT CHARACTER							
		0	1	2	3	4	5	6	7
LEAST SIGNIFICANT CHARACTER	0		centered *	SP	Ø	@	P	˘	p
	1	HP logo	centered o	!	1	A	Q	a	q
	2	β	†	"	2	B	R	b	r
	3		—	#	3	C	S	c	s
	4	upper-half tic	↓	\$	4	D	T	d	t
	5	lower-half tic	—	%	5	E	U	e	u
	6	left-half tic	√	&	6	F	V	f	v
	7	right-half tic	π	ˆ	7	G	W	g	w
	8	back space	Δ	(8	H	X	h	x
	9	1/2 shift down	μ)	9	I	Y	i	y
	A	line feed	° (degree)	*	:	J	Z	j	z
	B	inv. line feed	Ω	+	;	K		k	:
	C	1/2 shift up	ρ	.	<	L	\	l	<
	D	carriage return	Γ	-	=	M]	m]
	E	horizontal tic	θ	.	>	N	^	n	^
	F	vertical tic	λ	/	?	O	_	o	_

EXAMPLES:

HP logo	=	Ø1
A	=	41
i	=	69
√	=	16
▶	=	7F
line feed	=	Ø9

Figure 5-15. 1345A Modified ASCII Character Set

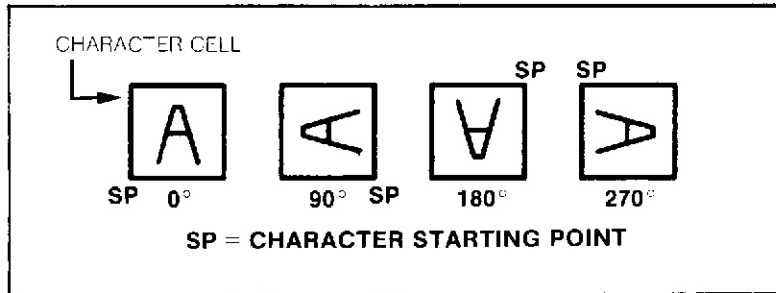

Figure 5-16. Character Rotation

Character rotation is an additional feature of the 1345A. The 1345A can be programmed to rotate any character at 0, 90, 180, or 270 degrees rotation measured counter clockwise from horizontal. This can be done for any character at any size. The starting point of the character is always the lower left corner relative to any rotation. For character rotation, the entire character area is rotated the specified number of degrees and the starting point moves around in a counter clockwise fashion. For example the starting point of a character rotated 180 degrees would be the upper right corner. This technique is illustrated in figure 5-16.

Since the starting point of the character changes with rotation, so does the direction of character spacing. If the rotation is 180 degrees, the characters will be written upside down from right to left. If the rotation mode is 270 degrees, the characters will advance from top to bottom. Rotation spacing examples are contained in figure 5-17.

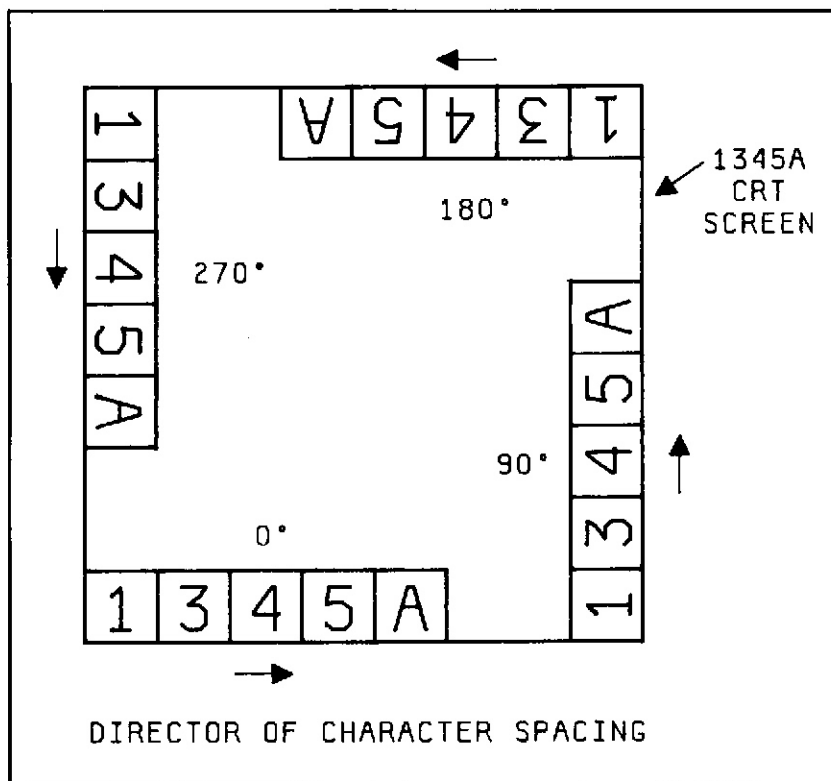

Figure 5-17. Character Rotation Spacing

Character generation on the 1345A has several capabilities that the user need be aware of. Certain characters that the 1345A is capable of drawing CANNOT be written within a certain distances of certain CRT screen boundaries. These characters are listed in Figure 5-18. The characters are referenced to the to the screen boundary at which the limitation occurs.

It is important to observe the recommended character boundary specifications, to avoid problems which might be encountered by writing at the screen edges. Figure 5-19 contains recommended limits for each character size at each screen edge. Failure to observe these limits may result in undefined results particularly when writing characters listed in figure 5-18. The user should plot all characters within these specified borders.

The user should not attempt to write any character along a screen edge. The character spacing guidelines in figure 5-19 allow ample spacing for characters of all specified sizes. Characters NOT specified in figure 5-18 may be written closer to the screen borders but it is not recommended.

BOUNDARY CHARACTERS	
Left Boundary:	Ø7 "right-half tic"; Ø8 "back space"; ØE "horizontal tic"; ØF "vertical tic"; 1Ø "centered *"; 11 "centered o"; 41 "A"; 57 "W"; 5F "└"; 77 "w"
Bottom Boundary:	Ø2 "β"; Ø5 "lower-half tic"; Ø9 "1/2 shift down"; ØA "line feed"; ØF "vertical tic"; 1Ø "centered *"; 11 "centered o"; 19 "μ"; 1C "ρ"; 24 "\$"; 28 "("; 29 ")"; 2C ";"; 3B ";"; 51 "Q"; 5B "["; 5D "]"; 5F "└"; 67 "g"; 6A "j"; 7Ø "p"; 71 "q"; 79 "y"; 7B "{"; 7D "}"
Top Boundary:	Ø1 "HP logo"; ØB "inv. line feed"; ØC "1/2 shift up"; 16 "√"; 1A "° (degree)"; 24 "\$"; 28 "("; 29 ")"; 38 "8"; 5B "["; 5D "]"; 7B "{"; 7D "}" ; 7E "□"
Right Boundary:	Ø1 "HP logo"; 16 "√"; 41 "A"; 51 "Q"; 57 "W"; 61 "a"; 71 "q"; 77 "w"; 7E "□"
NOTE: HEX character equivalents appear in quotation marks.	

Figure 5-18. Boundary Characters

Wrap Around. The user needs to be aware of a phenomenon called "wrap around". If one or more vectors are drawn outside the vector drawing area, the display will draw vectors on opposite sides of the CRT. One part of the vector will be at one side of the screen while the other part of the vector will be drawn on the opposite side of the CRT. The picture will appear distorted with visible vectors connecting ends of the vectors. This can be corrected by plotting inside the 1345A vector drawing area.

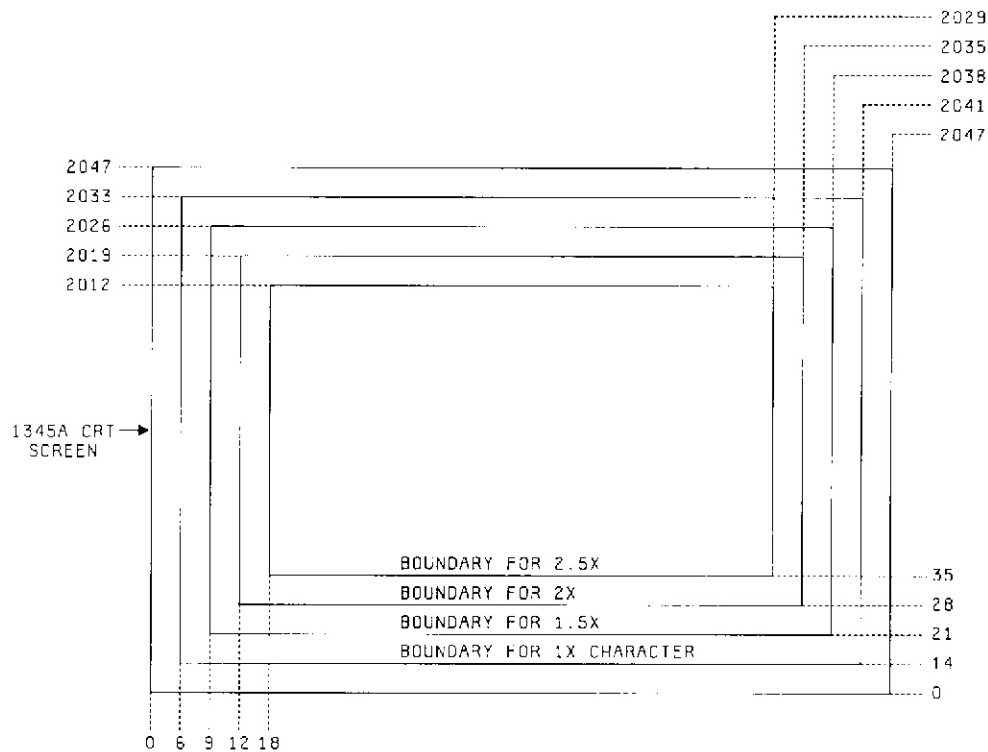

Figure 5-19. Character Borders

PROGRAMMING THE MEMORY OPTION (704).

The 1345A Memory Option stores up to 4k, 16 bit commands and refreshes the CRT thus relieving the user processor of data storage and CRT refresh requirements. The vector memory will appear to the user processor as a single memory location. The memory option recognizes two commands for programming. These commands are for data transfer and memory address pointer manipulation. A data transfer is either a read from or a write to the vector memory. Address pointer operations are used for positioning the data in the vector memory list and selecting a desired memory read address.

The vector memory contains a 4k by 16 bit memory, a 60 hz refresh timer, and two address pointers for accessing the memory. The timer is used to generate a refresh cycle of approximately 60 hz. This timer, when enabled will display the contents of the vector memory approximately once every 16.67 ms. There is a jumper on the memory board that allows the user to initiate the refresh cycle from an external source. This would be used to synchronize the refresh cycle with the user instrument data transfers or to refresh the display at a frequency other than 60 hz.

There are two pointers used to control access of data to and from the vector memory. One of these pointers is called the refresh pointer. It is enabled at the start of a refresh cycle and starts sequencing through vector memory until the end of memory is reached or an internal jump to 4095 is encountered. This is an internal memory address pointer that the user cannot access. The other pointer is called the Vector Memory Address pointer. This pointer is used to control data access to the vector memory. This pointer may be positioned by user commands for data transfer into and out of the vector memory list. In either case, an important fact is, that after a read or write operation the address of this pointer will increment by one.

Memory Board Commands.

The memory board has two commands for data transfer and positioning. A vector memory instruction is defined by the contents of the 16 bits on the data bus when the vector memory has received a write command from the user processor. The 16 bits will be decoded as either a vector memory write operation or an address pointer operation.

The vector data written into the memory can be either a picture data word or an internal jump command. The bit pattern for each is shown in figures 5-20 and 5-21.

NOTE: A0 referred to in the text is the A0 signal line on the 1345A I/O cable. NOT a pointer instruction or internal jump address bit.

M15	M14	M13	M12	M11	M10	M9	M8	M7	M6	M5	M4	M3	M2	M1	M0
0	B14	B13	B12	B11	B10	B9	B8	B7	B6	B5	B4	B3	B2	B1	B0

(SEE DATA BIT DEFINITIONS FOR 1345A COMMANDS)

Figure 5-20. Vector Memory Word

An internal jump does not affect the Vector Memory address pointer.

M15	M14	M13	M12	M11	M10	M9	M8	M7	M6	M5	M4	M3	M2	M1	M0
1	0	X	X	A11	A10	A9	A8	A7	A6	A5	A4	A3	A2	A1	A0

X = DON'T CARE
M15 = 1, M14 = 0: Internal jump to Vector Memory address specified by A11 thru A0 during refresh.

Figure 5-21. Internal Jump

The data sent to the vector memory is dependent on the status of the A0 and M15 signal lines. When A0 is high and M15 is low, the 15 data bits M0-M14 contain 1345A commands. These commands must conform to the bit pattern definitions in the "1345A Commands" discussed earlier. During a refresh cycle this data is used to refresh the 1345A for vector/character generation. The data needs to be sent only once to the vector memory. If A0 is high and M15 is high, then bits M0-M11 designate the address of the next word in vector memory that will be sent to the 1345A Vector Processor during a refresh cycle. This allows the user to skip selected sections of memory at any time. The memory map in figure 5-22 illustrates the use of this capability. There are several pictures in memory that can be skipped or displayed depending on the address in the jump commands. When desired, a suppressed block of data can be displayed by changing the jump word address.

*NOTE: An address specified in a jump command CANNOT contain another jump instruction. An internal jump command affects only the refresh circuitry not the vector memory address pointer.

VECTOR MEMORY	
Address	Contents
0000	Jump to 1002
0001 to 1000	Picture A
1001	Jump to 1002
1002 to 2002	Picture A
2003	Jump to 2062
2004 to 2060	Graticule A
2061	Jump to 2062
2062 to 2147	Graticule B
2148	Jump to 4095
2149 to 2255	Set of labels
2256	Jump to 4095
2257 to 4094	Unused memory
4095	No-Op

Figure 5-22. Typical 1345A Vector Memory Map

Address Pointer.

When A_0 is low, M15 is ignored. This specifies that the data in bits M0-M11 designate the address to which the Vector Memory Address Pointer will move. This is the next address available for a read or write operation. The pointer value is placed in the Vector Memory pointer register, not in Vector Memory. The required bit pattern for pointer commands is shown in figure 5-23. This pointer auto INCREMENTS by one for each read or write operation commanded by the user processor. A pointer value of 4095 will increment to a value of zero.

M15	M14	M13	M12	M11	M10	M9	M8	M7	M6	M5	M4	M3	M2	M1	M0
X	X	X	X	A ₁₁	A ₁₀	A ₉	A ₈	A ₇	A ₆	A ₅	A ₄	A ₃	A ₂	A ₁	A ₀
X = DON'T CARE															
A ₀ = 0: Set pointer register to the Vector Memory address value specified by A ₁₁ thru A ₆ .															

Figure 5-23. Pointer Command Bit Pattern

Vector Memory Management.

Using the memory option (704) in a 1345A system requires some additional considerations not necessary with a standard 1345A. Figure 5-24 contains a typical instrument block diagram with the memory option installed.

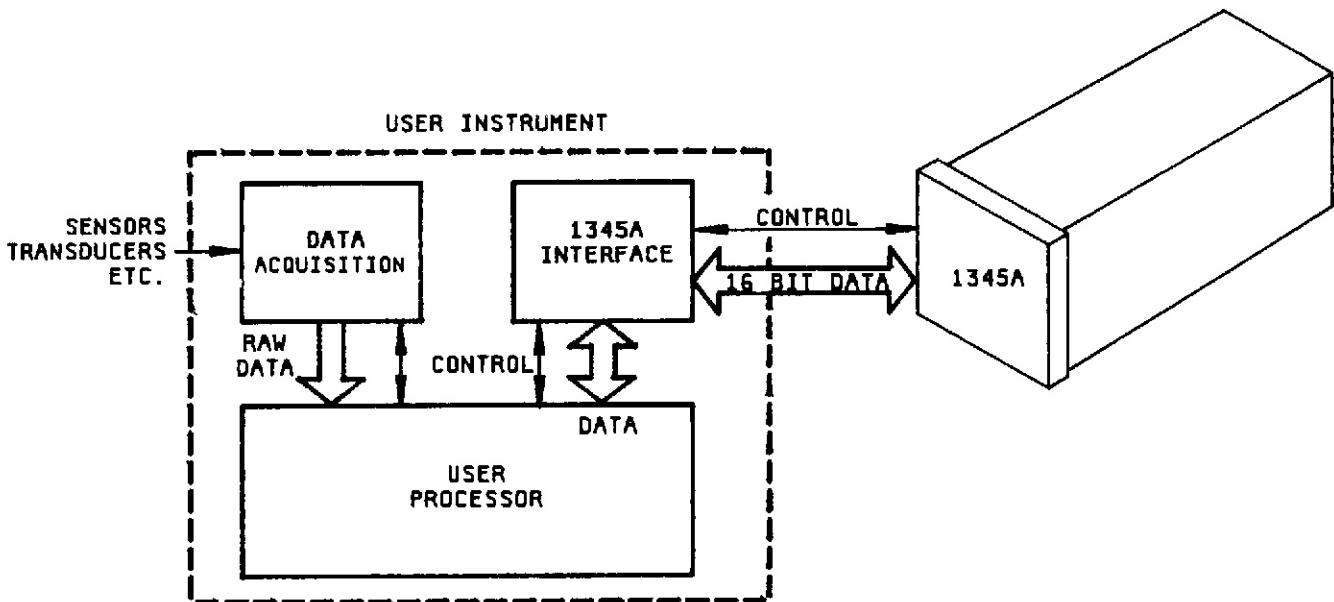

Figure 5-24. Typical Instrument With Memory Option 704

The main advantage of the memory option is that it relieves the user processor from the task of display refresh. However, effective use of the memory option requires that the user have a memory management scheme for data transfer to and from the vector memory. An example memory map is shown in figure 5-25.

The memory map example has six data fields that can be displayed. The link in front of each data block contains a no-op and a jump command. A no-op is a zero word. This is equivalent to a plot $X=0$ command. If a picture data block is to be suppressed, then the link in front of that block will contain a jump address to a no-op of another link. If vector data contained in the data block is to be displayed, then the jump address will be the starting address of the data block. To alter the status of a block of picture data, the user processor needs to position the memory address pointer to the address of the link to be modified and write a jump command into the link with the new jump address. To alter data, the Vector Memory address pointer needs to be positioned to the starting address of the data block and the user processor then writes the display data into the vector memory. The length of each data block needs to be greater than or equal to the maximum amount of data to be displayed from that block. The user processor must insure that the data within each block is initialized and maintained so that erroneous data is not left in the data block when a new and smaller set of data is stored. The user can manage each block by putting a jump command at the end of the data that jumps to the link of the next data block. It is recommended that the user write a no-op into address 4095. Then 4095 can be used as a jump address from data blocks. This will also provide an easy method to use synchronous refresh. It should be noted that jumps can be forward or reverse within the vector memory.

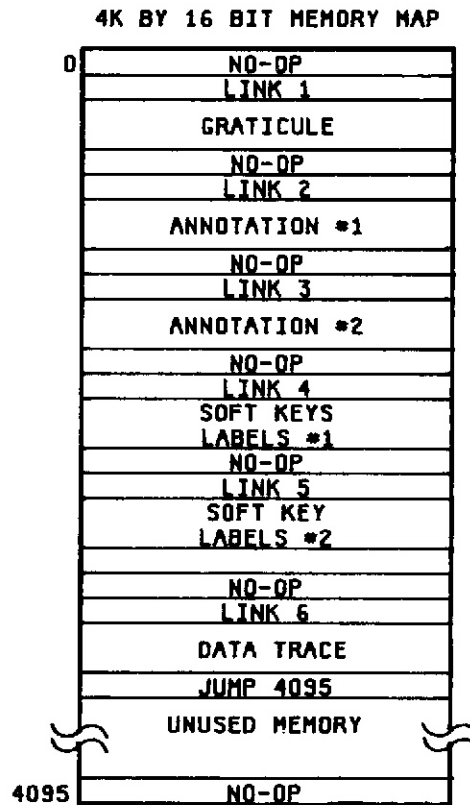

Figure 5-25. Example Vector Memory Map

Memory Initialization.

When the memory is initially turned on the contents will be unknown. It is recommended that the user initialize the memory as follows.

Since synchronous refresh can only occur after an internal "jump to 4095" command, the user may want to fill the memory with internal jumps to 4095 during initialization. The benefit of this method is that no matter how large or small the picture is, there is a jump to 4095 at the end of the picture data. This will initiate synchronous refresh and the picture will then be displayed at optimum brightness. Another method of initialization is to fill the entire memory with zeroes. This is equivalent to a no-op. The data will be sent to the 1345A but nothing will be drawn. This is not as efficient as the first method because the refresh is not optimized. By not executing a jump to 4095 the 1345A will not operate in synchronous refresh mode.

NOTE: Location 4095 should contain a no-op (0000_h). A jump to 4095 = 8FFF_h.

The two refresh techniques apply to external user memory as well. If the user processor accesses a defined memory space for 1345A display data, the data to be sent to the 1345A will follow either the synchronous or asynchronous method of display refresh. The refresh rate requirement must still be met. The only difference in this case is that the user processor must handle the refresh of the 1345A.

Reading the Vector Memory.

The data contained in the vector memory can be read by the user processor. This data may be used for additional data processing, external hard copy plotting etc. This feature allows the user to read and

verify the contents of the vector memory. This feature is activated by setting the \overline{RD} line to a low state while DS is low and reading the contents of the 1345A 16 bit data bus. The user needs to set the Vector Memory address pointer to the desired memory address and start the read process.

DISPLAY PERFORMANCE CONSIDERATIONS.

To obtain optimum performance from the 1345A Digital Display, there are a few performance parameters that need consideration. These are refresh rate, picture complexity and vector data rate. This particular section of this manual will present these different parameters with respect to overall display performance.

Refresh Rate.

The refresh rate of the 1345A is controlled by either the user interface or the memory option board. The recommended refresh rate is at least 60 hz. The minimum recommended refresh rate is 45 hz. Between 45 hz and 60 hz, display flicker may be visible depending on observer viewing conditions. Two anomalous conditions may result from an inadequate refresh rate. The picture may appear dimmer than usual or will visibly oscillate in brightness. If one of these problems arise, either the refresh rate is not fast enough or the picture contains excessive vector length to display within the refresh cycle.

There are two types of display refresh available to the user processor. The methods are asynchronous or synchronous refresh. The timing diagrams in figures 5-26 and 5-27 illustrate both methods of refresh.

These timing diagrams are intended for use with the memory option but can apply to external user memory as well.

The synchronous refresh mode is established when the Vector Memory sends picture data to the 1345A and then executes an internal jump to 4095. The Vector Memory then waits for a sync pulse before beginning the next data output cycle. The sync pulses can be either internal or external. The internal sync is generated by an internal 60 hz oscillator. External sync pulses must be supplied by an external source that generates TTL level pulses at a desired refresh rate. The external sync is input through the SYNC line on the rear panel connector of the 1345A. This option is selected by a jumper on the vector memory circuit board. Asynchronous display refresh mode is generated by two conditions. The first condition occurs when the picture cannot be drawn in the time interval between sync pulses. When this situation occurs, sync pulses are ignored. The refresh rate is controlled by the time it takes the vector memory to send the data to the 1345A Vector Processor. This situation usually occurs if there are many long vectors in the picture. Since longer vectors take more time to draw the 1345A prevents the Vector Memory from sending the next data word until the current vector is done. Asynchronous refresh also occurs when Vector memory location 4095 is reached during a refresh cycle without an internal jump to 4095 occurring. It is recommended that the Vector Memory be made to jump to address 4095 after the picture data to minimize time between refresh cycles and avoid asynchronous refresh.

PICTURE COMPLEXITY.

The degree of picture complexity is a direct function of the TOTAL LENGTH of the vectors drawn on the 1345A display. Since ALL data to be displayed should be transmitted to the 1345A 60 times a second, three performance parameters require attention. These are the vector writing speed, average vector length and the number of characters to be displayed.

Picture A and B will be displayed at an even brightness (sync rate = refresh rate) even though picture A requires less drawing time.

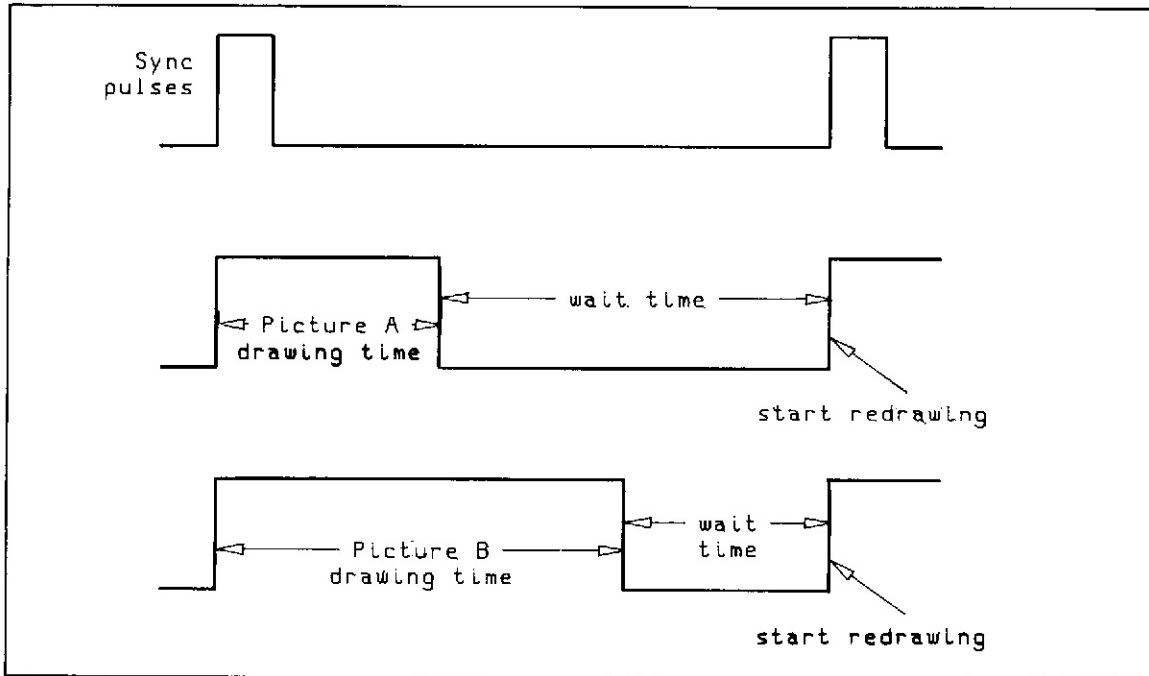

Figure 5-26. Synchronous Refresh

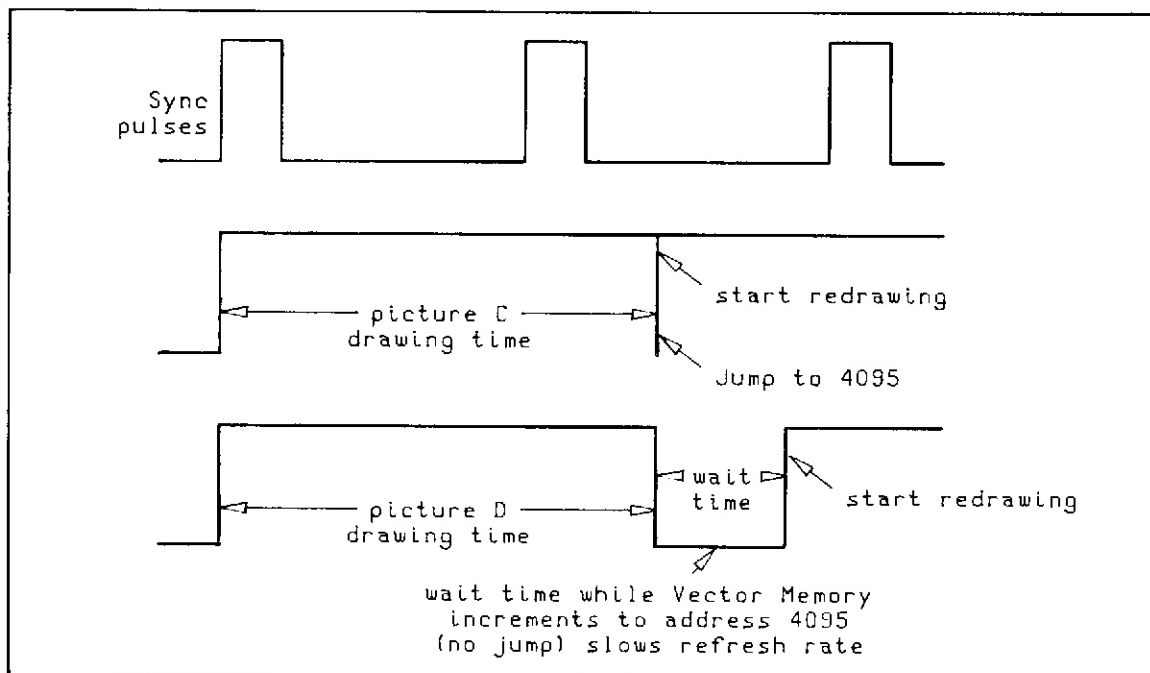

Figure 5-27. Asynchronous Refresh

The 1345A has the capability of drawing vectors at several writing speeds. Writing speed is defined as the speed at which the beam is deflected across the CRT screen. The 1345A has the capabilities contained in figure 5-28, which compares writing speed and maximum total vector length which the 1345A can draw at a 60 hz refresh rate.

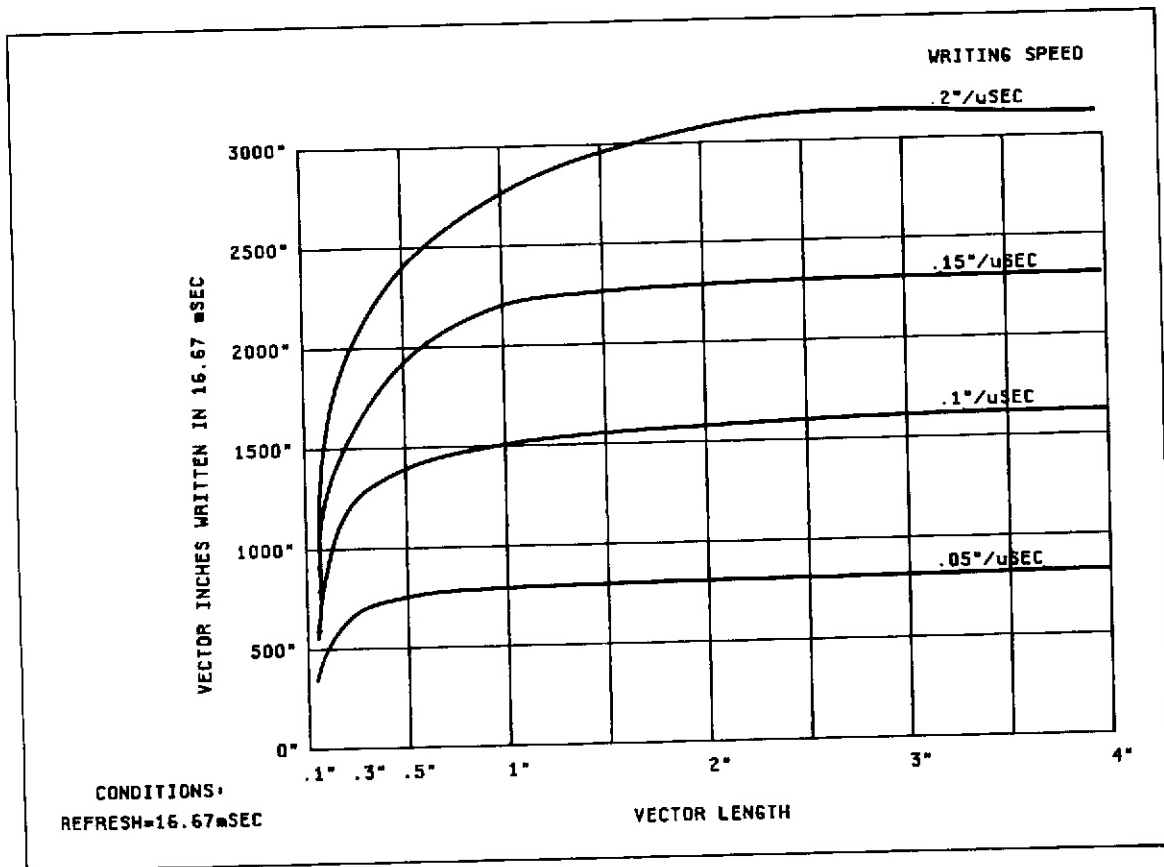

Figure 5-28. Vector Length vs Writing Speed for 60 Hz Refresh Rate

The specified number of vector inches in figure 5-28 can be written with a refresh cycle time of 16.67 ms. This is the refresh cycle time for a 60 hz refresh rate. Additional refresh frame time is required when text is added to the vector display. Many applications will require that some text also be written on the screen. figure 5-29 summarizes the capabilities of the 1345A for various text and vector length combinations.

The data in this table was generated using the equations in figure 5-30. To generate data for other writing speeds and character combinations, insert the appropriate values of the variables into the equations and calculate the time it takes to draw each portion of the picture.

Generating a complex picture requires knowledge of the number of vectors required. Two pictures will be used as examples that have quite different appearances. The methods used to generate these pictures will be discussed. These two pictures are shown in figures 5-31 and 5-32. The generation of these pictures will be discussed to give the user an idea of what is involved in generating such a picture.

Conditions.				
Average character drawing time: 16 μ sec				
Recommended refresh rate: 60 Hz ~ 16.6 msec				
1345A writing speed: 0.1 in./ μ sec				
Vector dead time: 1 μ sec				
	NUMBER OF CHARACTERS TO BE DRAWN			
	0	100	200	300
Total frame time (msec)	16.67	16.67	16.67	16.67
Character writing time (msec)	0	1.60	3.20	4.80
Time left to draw vectors (msec)	16.67	15.07	13.47	11.87
AVERAGE VECTOR LENGTH	APPROXIMATE NUMBER OF VECTORS DRAWN			
0.1 in.	8330	7530	6730	5930
0.5 in.	2770	2510	2240	1970
2.0 in.	790	710	640	560
6.0 in.	270	240	220	190

Figure 5-29. 1345A Capabilities for Character and Vector Combinations

$\text{VECTOR DRAWING TIME} = \frac{\text{VECTOR LENGTH}}{\text{WRITING SPEED}} + \frac{1 \mu\text{s}}{\text{VECTOR}}$
$\text{PICTURE DRAWING TIME} = \sum_1^N \frac{\text{VECTOR LENGTH}}{\text{WRITING SPEED}} + \frac{1 \mu\text{s}}{\text{VECTOR}} + \sum_1^M \frac{15 \mu\text{s}}{\text{CHARACTER}}$
N = TOTAL NUMBER OF VECTORS
M = TOTAL NUMBER OF CHARACTERS

Figure 5-30. Vector Drawing Time Calculations

The first picture, figure 5-31, is similar to a spectrum analyzer. This picture contains 750 vectors per data trace and 265 characters. There are 22 vectors in the graticule and 1500+ in the data traces. By using the table in figure 5-29, the 1345A can display up to 1970 0.5 in. vectors at a writing speed of 0.1 in./ μ s. In these examples, the writing speed is set at 0.5 in./ μ s. At that writing speed and an average of 0.1 in. per vector, the 1345A can draw up to 3956 vectors and up to 300 characters. This trace has 1500+ vectors and 265 characters. The 1345A could draw over twice as many vectors as shown in this example within the 16.67 ms refresh cycle time.

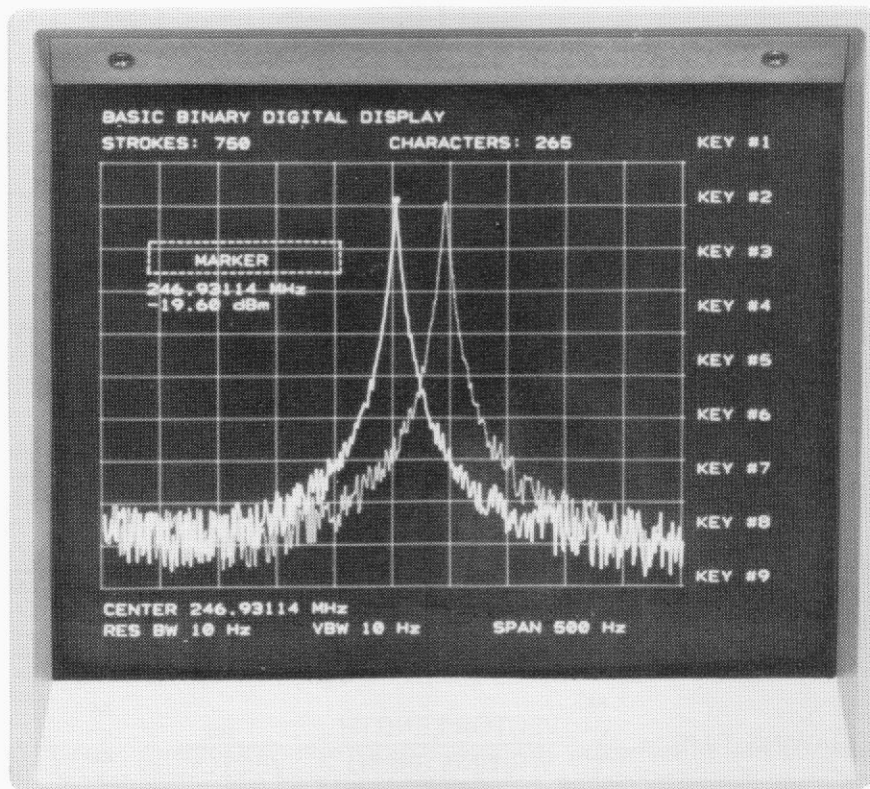

Figure 5-31. Typical Spectrum Analyzer Presentation

The second picture, figure 5-32, is similar to a "SMITH CHART". There are 528 vectors in the graticule and a total of 133 characters used for annotation. The graticule in this picture is more complex and requires more vectors. Notice that the vectors in this graticule are very short and give the appearance of a curve. There are 150 vectors in the trace. These are also very short vectors and give the appearance of a curve. The vectors were drawn at a writing speed of 0.5 in./ μ s. The 1345A can draw over 4400 0.1 in. vectors and 200 characters within a 16.67 ms refresh cycle time. In this display, there are a total of 678 vectors and 133 characters. The 1345A could draw over 7 times as many 0.1 in. vectors and up to 200 characters and still satisfy a 60 Hz refresh requirement.

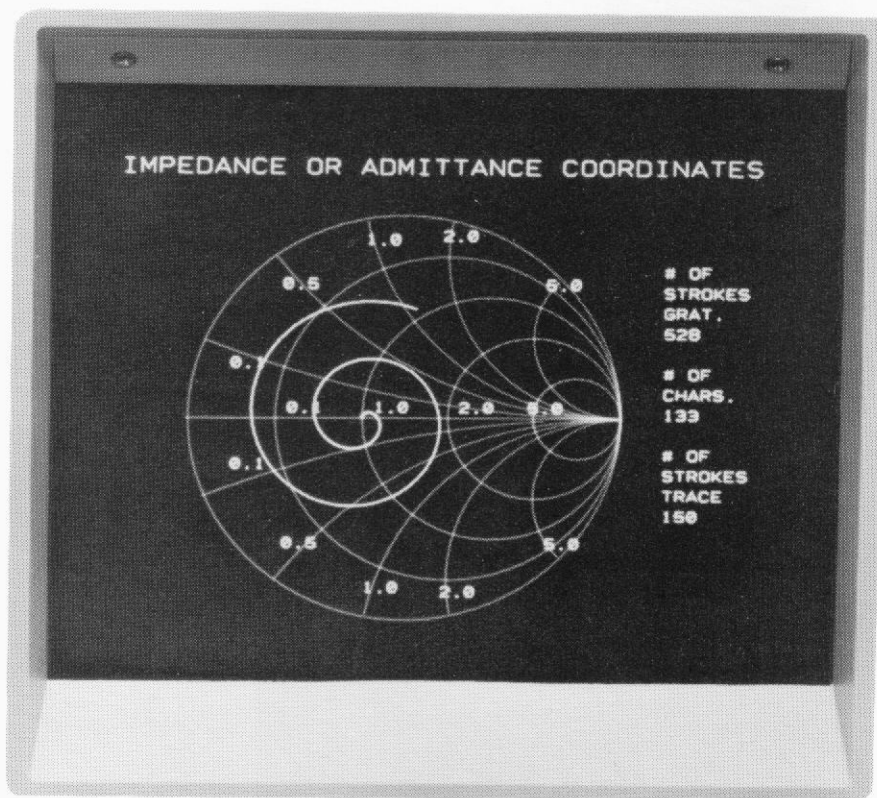

Figure 5-32. A Typical Smith Chart Presentation

In figure 5-33, there are two additional examples of typical 1345A instrumentation displays.

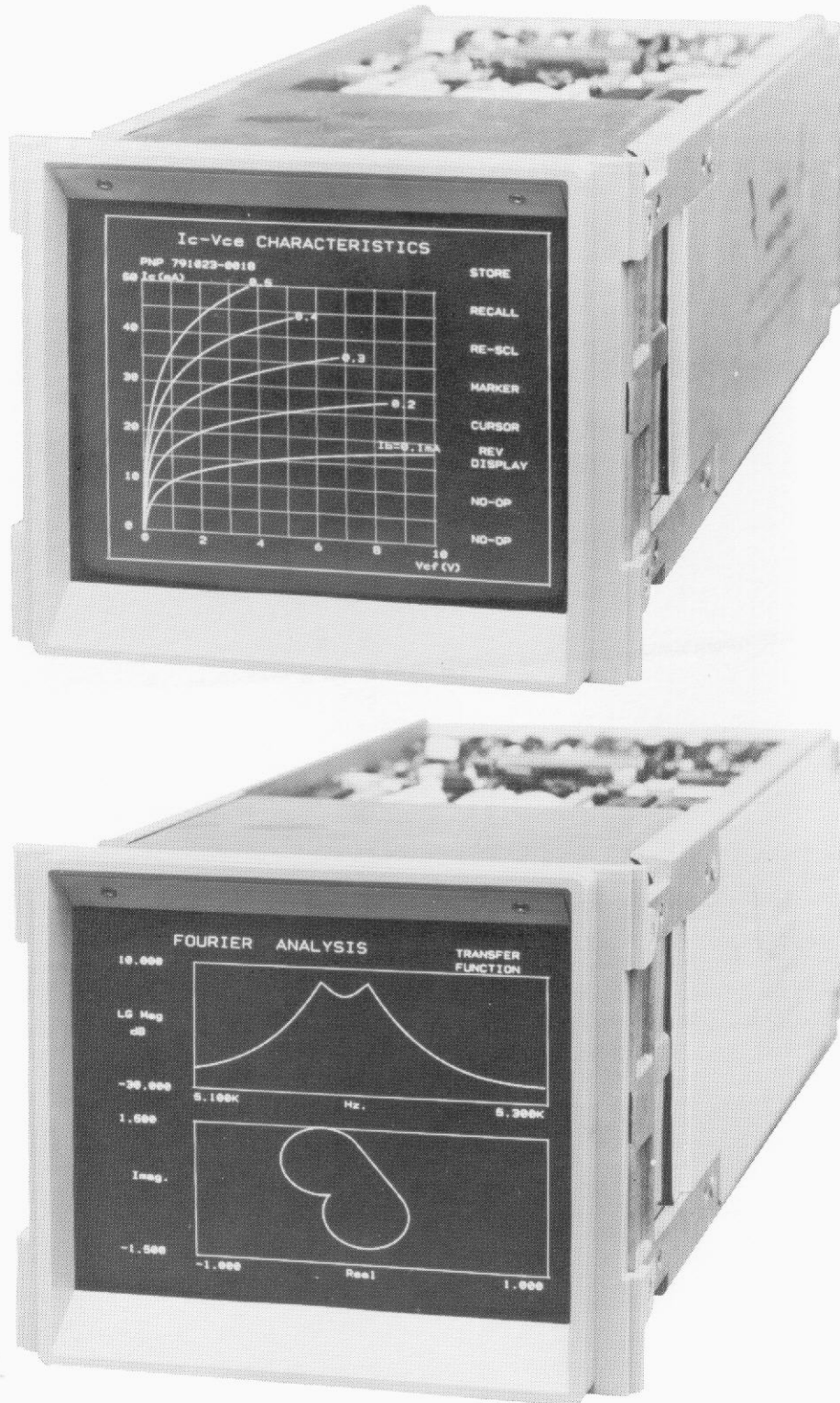

Figure 5-33. Additional 1345A Example Displays

APPENDIXES

1345A Quick Reference Guide

1345A COMMANDS.

NOTE: Bit D15 is used only for vector memory board commands. For standard 1345A commands, D15 should be 0.

1345A 16 Bit Data Word.

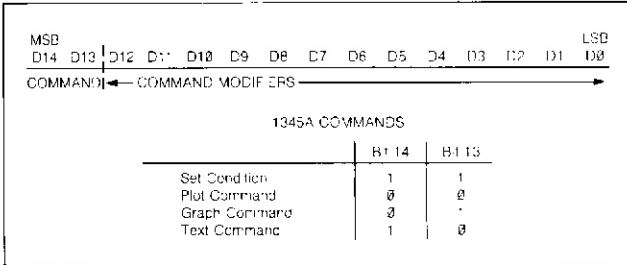

Set Condition Command.

Set Condition Command:

MSB	D14	D13	D12	D11	D10	D9	D8	D7	D6	D5	D4	D3	D2	D1	D0	LSB
1	1	1	1	1	X	X	L	L	0	X	W	W	X	X	X	X

Note: Bit 6 (D6) must be zero.

Command Modifiers:

- To Set Line Intensity:

L1	L0	Intensity
0	0	Blank
0	1	Dim
1	0	Half Brightness
1	1	Full Brightness
- To Set Line Type:

L1	L0	Type
0	0	Solid Line
0	1	Intensified End Points on Solid Line
1	0	Long Dashes
1	1	Short Dashes
- To Set Writing Speed:

W1	W0	Speed
1	1	0.05 in. per μs
1	0	0.10 in. per μs
0	1	0.15 in. per μs
0	0	0.20 in. per μs

Plot Command.

Plot Command:

MSB	D14	D13	D12	D11	D10	D9	D8	D7	D6	D5	D4	D3	D2	D1	D0	LSB
0	0	XY	PC	D14	D13	D12	D11	D10	D9	D8	D7	D6	D5	D4	D3	D2

Command Modifiers:

- XY Information (D12):
 - 0 = X coordinate (0-2047), specified by D10-D11
 - 1 = Y coordinate (0-2047), specified by D10-D11
- PC Beam Control Information (D11):
 - 0 = Beam OFF (move)
 - 1 = Beam ON (draw)

Programming Command Ranges.

PROGRAMMING COMMAND RANGES OF THE 1345A		
1345A Command	Decimal Range	Hexadecimal Range
a. Plot		
X	00000-07777	0000-07FF
Y (beam off)	10000-13777	1000-13FF
Y (beam on)	14000-17777	1800-1FFF
b. Graph		
Set Delta-X	20000-27777	2000-2FFF
Y (beam off)	30000-33777	3000-3FFF
Y (beam on)	34000-37777	3800-3FFF
c. Text	40000-57777	4000-5FFF
d. Set Condition	60000-77777	6000-7FFF

Graph Command.

Graph Command:

MSB	D14	D13	D12	D11	D10	D9	D8	D7	D6	D5	D4	D3	D2	D1	D0	LSB
0	1	XY	PC	D14	D13	D12	D11	D10	D9	D8	D7	D6	D5	D4	D3	D2

Command Modifiers:

- XY Information (D12):
 - 0 = Set Delta-X increment, specified by D8-D10 for all subsequent Y coordinates
 - 1 = Set Y coordinate, specified by D8-D10. The beam is to be moved to this Y in conjunction with the Delta X increment.
- PC Beam Control Information (D11):
 - 0 = Beam OFF (move)
 - 1 = Beam ON (draw)

MEMORY BOARD COMMANDS.

Vector Memory Word.

M15	M14	M13	M12	M11	M10	M9	M8	M7	M6	M5	M4	M3	M2	M1	M0
0	B14	B13	B12	B11	B10	B9	B8	B7	B6	B5	B4	B3	B2	B1	B0

(SEE DATA BIT DEFINITIONS FOR 1345A COMMANDS)

Internal Jump.

An internal jump does not affect the Vector Memory address pointer.

M15	M14	M13	M12	M11	M10	M9	M8	M7	M6	M5	M4	M3	M2	M1	M0
1	0	X	X	A11	A10	A9	A8	A7	A6	A5	A4	A3	A2	A1	A0

X = DON'T CARE
M15 = 1, M14 = 0: Internal jump to Vector Memory address specified by A1 thru A0 during refresh.

Address Pointer.

M15	M14	M13	M12	M11	M10	M9	M8	M7	M6	M5	M4	M3	M2	M1	M0
X	X	X	X	A11	A10	A9	A8	A7	A6	A5	A4	A3	A2	A1	A0

X = DON'T CARE
A0 = 0: Set pointer register to the Vector Memory address value specified by A1 thru A0

1345A Modified ASCII Character Set.

1345A MODIFIED ASCII CODE CONVERSION TABLE

LEAST SIGNIFICANT CHARACTER	MOST SIGNIFICANT CHARACTER							
	0	1	2	3	4	5	6	7
0		centered	SP	@	P		p	
1	HP logo	centered r	1	A	Q	a	q	
2	β		2	B	R	b	r	
3			3	C	S	c	s	
4	upper half tic		4	D	T	d	t	
5	lower half tic		5	E	U	e	u	
6	left half tic	√	6	F	V	f	v	
7	right half tic	π	7	G	W	g	w	
8	back space	Δ	8	H	X	h	x	
9	1/2 shift down	α	9	I	Y	i	y	
A	line feed	0 degrees		J	Z	j	z	
B	no line feed	0		K		k		
C	1/2 shift up	π		L		l		
D	carriage return	1°		M		m		
E	horizontal tic	#		N		n		
F	vertical tic	λ		O		o		

EXAMPLES:

HP logo = 01
 A = 41
 √ = 69
 π = 16
 Δ = 27
 line feed = 09

Text Command.

Text Command:

MSB	D14	D13	D12	D11	D10	D9	D8	D7	D6	D5	D4	D3	D2	D1	LSB
1	0	S1	S2	R1	R2	CS	CR	CR	CR	CR	CR	CR	CR	CR	CR
CHARACTER →															

Command Modifiers:

For CR-CR, see modified ASCII conversion table

a. ES Establish Size of Character

0 = Use previous size and rotation
 1 = Establish new size and rotation according to S1, S2, R1 and R2

b. Rotate Character CCW

R1	R2	Rotation
0	0	0 degrees
0	1	90 degrees
1	0	180 degrees
1	1	270 degrees

S1	S2	Size	W x H (in addressable points)
0	0	1X	24 x 36
0	1	1.5X	36 x 54
1	0	2X	48 x 72
1	1	2.5X	60 x 90

Capabilities for Character and Vector Combinations.

Conditions:

Average character drawing time: 16 msec
 Recommended refresh rate: 60 Hz = 16.6 msec
 1345A writing speed: 0.1 in./msec
 Vector draw time: 1 sec

	NUMBER OF CHARACTERS TO BE DRAWN			
	0	100	200	300
Total frame time (msec)	16.67	16.67	16.67	16.67
Character writing time (msec)	0	1.60	3.20	4.80
Time left to draw vectors (msec)	16.67	15.07	13.47	11.87

AVERAGE VECTOR LENGTH	APPROXIMATE NUMBER OF VECTORS DRAWN			
	0.1 in.	8330	7530	6730
0.5 in.	2770	2510	2240	1970
2.0 in.	790	710	640	560
6.0 in.	270	240	220	190

Vector Drawing Time Calculations.

$$\text{VECTOR DRAWING TIME} = \frac{\text{VECTOR LENGTH}}{\text{WRITING SPEED}} + \frac{1 \mu\text{s}}{\text{VECTOR}}$$

$$\text{PICTURE DRAWING TIME} = \sum_{1}^N \frac{\text{VECTOR LENGTH}}{\text{WRITING SPEED}} + \frac{1 \mu\text{s}}{\text{VECTOR}} = \sum_{1}^M \frac{15 \mu\text{s}}{\text{CHARACTER}}$$

N = TOTAL NUMBER OF VECTORS
 M = TOTAL NUMBER OF CHARACTERS

Vector Length vs. Writing Speed for 60 Hz Refresh Rate.

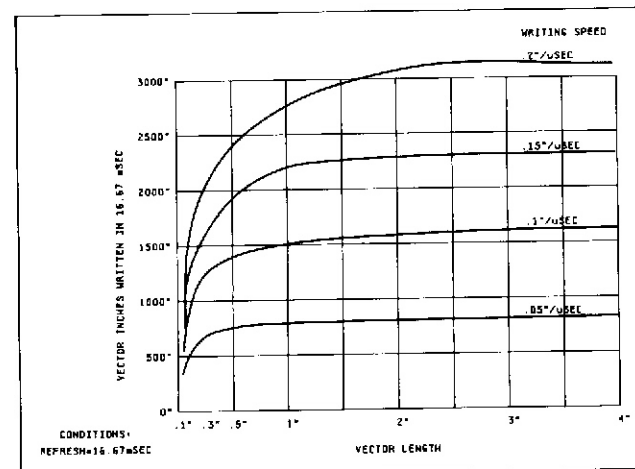

Character Rotation.

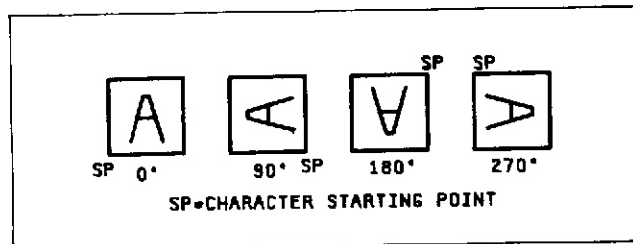

APPENDIX B

HP CLASS B SHOCK AND VIBRATION TESTS

SHOCK AND VIBRATION.

The Model 1345A is designed to meet all HP Class B Shock and Vibration Standards. The following specifications and procedures are used by HEWLETT-PACKARD to shock and vibration test the instrument. The instrumentation and procedures stated herein may be used as guidelines for instrumenting and measuring the actual shock and vibration to which the 1345A may be subjected to in the system. The results of those measurements should be compared to HEWLETT-PACKARD's specification and measurements.

SHOCK TEST SPECIFICATIONS.

The product shall be able to withstand the shock levels as shown in table B-1 and there shall be no significant physical damage, bending or electrical malfunction. The product shall be capable of operating and performing to its specified accuracies. This test is designed to show structural rigidity of the product as well as its ability to survive a crash environment. The Class B Shock Tests are performed in a non-operating environment. Shock levels and pulse duration in table B-1 are based on the criterion that the product of acceleration and time shall remain approximately constant.

Table B-1. Minimum Shock Level Withstand Capability

Class	Product Weight (kg)	Shock Intensity (g)	Shock Pulse Duration (milliseconds)
B	4.4 kg	30	11

INSTRUMENTATION.

Before mounting the product under test, the combination of table and a simulated mass should be calibrated to be certain that the maximum acceleration is not exceeded and that the resultant waveform is within the tolerance of the machine. It may be desirable to instrument questionable elements of construction. Accelerometers may be attached to points of interest and monitored with the regular tests.

For consistent results between test facilities, a simulated lab bench shall be a 3/4 inch of plywood laid on a concrete floor.

MOUNTING.

The product is mounted on the shock table with covers and side panels attached. Restrainers which are used for shipment should be attached (e.g., card restrainers, special straps or clamps, etc.).

The product should be blocked up so that stress is imparted directly to the chassis and not through shock mounted feet, handles or any other dampers. The intent is to simulate the product's exposure in its shipping package as well as handling stresses as seen in a shop or mobile environment.

APPENDIX C

CONFIGURING THE 1345A VECTOR MEMORY (OPTION 704).

The optional vector memory can be configured for either internal or external refresh synchronization. The factory setting is for internal refresh synchronization. To modify the vector memory for external refresh synchronization use the following procedure.

1. Remove the 4 screws holding the vector processor board to the 1345A frame.
2. Tilt the vector processor board out of the frame exposing the vector memory board.
3. Locate the small jumper wire between the IC's U1 and U2 using figure C-1 as a guide.
4. Remove the jumper from between the "I" and middle solder pads.
5. Replace the jumper between the middle and "E" solder pads.
6. Replace vector processor board onto the 1345A frame.
7. Replace the 4 screws to secure vector processor to the 1345A frame.

The vector memory will now start a refresh cycle by external stimulus. The signal needed is a TTL level positive going edge on the SYNC line of the 1345A I/O connector.

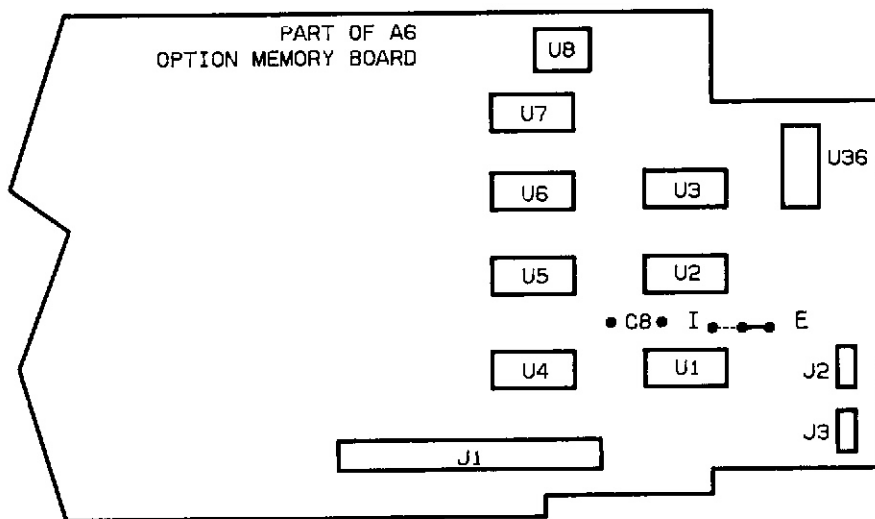

Figure C-1. Internal/External Jumper Locator