



Model 4410

Guildline

Portable DC Voltage Standard



Features

- Eight independent outputs
- High reliability
- Low drift
- Low noise
- Excellent line isolation
- Suitable for small labs
- Easily transportable
- Acceptable for National Certification
- Long battery backup
- Battery voltage immunity
- Low temperature coefficient
- Ease of operation

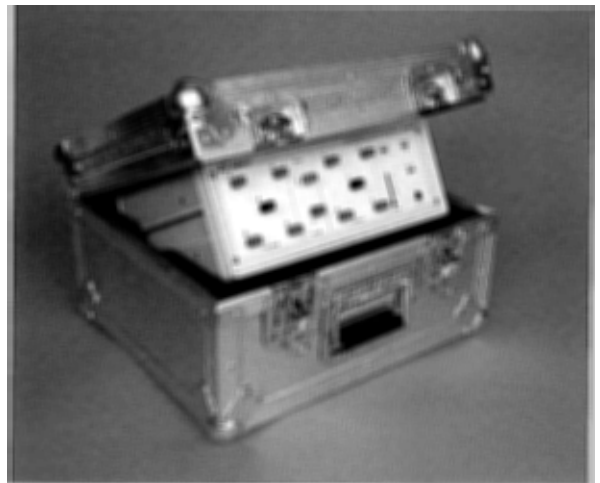

PERFORMANCE SPECIFICATIONS

LINE IMMUNITY

Battery Charging Section:

On 120V setting: 96V to 144V

On 240V setting: 192V to 288V

Output voltage of charger maintained within $\pm 2.5\%$ of recommended "float" voltage for the sealed lead-acid batteries included. For line frequency 45Hz to 65Hz.

Output:

Influence of battery voltage within the limits of 11.6V and 14V (Low alarm point 11.7V) on the output: Limit: below noise.

NOISE

Less than:

0.1 ppm RMS.

0.3 Hz to 10 Hz bandwidth.

ANNUAL DRIFT

Each of the 8 outputs (continuously energised)

First year, limit: $- 3 \pm 2$ ppm

Second year, limit: $- 2 \pm 2$ ppm.

HYSTERESIS

After de-energisation for up to 2 days (battery totally discharged and not powered by line) and after 150 hours settling time. Total change, limit: less than 0.5 ppm.

TEMPERATURE COEFFICIENT

Less than:

± 0.04 ppm/ $^{\circ}$ C.

Within oven control ambient range of 16 $^{\circ}$ C to 28 $^{\circ}$ C.

This temperature performance can be degraded by improper connection techniques, giving rise to thermal emf's in the test lead connections, particularly for the 1.018V outputs.

OVEN MONITOR

Oven operation may be checked by an independent and isolated thermistor mounted in the oven mass and accessible at the rear panel. The thermistor resistance is tabulated on the calibration report.

ISOLATION, AC

Case to guard AC leakage current:

Less than 120 nA at 60Hz line frequency.

Less than 100 nA at 50Hz line frequency.

LEAKAGE RESISTANCE

Outputs to guard: greater than 10^{10} Ohms

Outputs to case: greater than 10^{11} Ohms

Case to guard: greater than 10^{11} Ohms

Measured at 50% relative humidity and 20 $^{\circ}$ C after 24 hours operation on line power.

OPERATION ON BATTERY

Shipped fitted with two 12V, 7 A-H sealed lead-acid batteries, fully charged and operating in ambient not less than 20 $^{\circ}$ C: > 80 Hours.

In Transit Mode in Transit case after warm-up, in 20 $^{\circ}$ C ambient:

> 130 Hours.

Battery operation time is a function of ambient temperature, and is longer at higher temperatures, shorter at lower.

ACCESSORIES

Reinforced Aluminum Foam-lined Transit case.

Technical manual.

Initial calibration records.

National Laboratory certificate (Optional).

Batteries fitted.

Detachable line cord.

DIMENSIONS

Instrument: Width 14.4, Height 5.9, Depth 10.6 inches.

Instrument: Width 365, Height 150, Depth 270 mm.

Transit Case: Length 21.7, Height 19.7, Width 11.8 inches.

Transit Case: Length 550, Height 500, Width 300 mm.

WEIGHT

Instrument: 27lb. 8oz (12.5kg)

Transit Case: 20lb. 7oz (9.3kg)

POWER REQUIREMENT

120V $\pm 20\%$, OR 240V $\pm 20\%$, 45-65Hz,

15 Watts maximum.

OTHER MODELS IN THIS SERIES

4470

Is identical to the 4410, except it has four 10V outputs with specifications as above, and four outputs of approximately 6.9V instead of 1.018V. These are directly buffered from the reference elements and offer slightly improved drift and noise performance for the most demanding applications such as international volt transfers.

4400

Has only four outputs of 10V as specified above.

4100

Is a working voltage reference. Preliminary data follows: 4100 has a single output each of 10V, 6.9V, 1.018V, 1V and 20mV, all fixed, plus a digitally trimmable high current (20mA) output which can be switched to any of these emf sources. Thus, if the 10V output were selected, it could be keyboard trimmed against the laboratory prime standard and then used for routine work. Also embodied in this instrument is a high sensitivity null detector. General performance parameters as for 4410.

This instrument was designed and developed in Australia by STATRONICS with the collaboration of the National Measurement Laboratory (CSIRO Division of Applied Physics)



GUILDLINE INSTRUMENTS

USA: Guildline Instruments Inc.,

4403 Vineland Road • Suite B10 • Orlando, Fla. 32811-7335 • (305) 423-8215 Telex: 856443 Fax: (305) 422-5987

CANADA & OVERSEAS:

Guildline Instruments Ltd.,

P.O. Box 99 • 21 Gilroy St. • Smiths Falls, Ontario K7A 4S9 • Canada • (613) 283-3000 Telex: 053-3028 Fax: (613) 283-6082

VOLTAGE STANDARD

MODEL 4410

TECHNICAL MANUAL

Whilst the information contained in this manual is believed to be accurate, no responsibility whatever is accepted for any errors or omissions. Furthermore, no responsibility is accepted for any consequential loss incurred through application or mis-application of the information contained herein, whether erroneous or not. Reasonable steps will be taken to inform 4410 OWNERS of any changes, however the contents of this manual are subject to change without notice.

The contents and information contained in this manual are proprietary to Guildline Instruments. They are to be used only as a guide to the operation of the equipment with which this manual was issued and may not be duplicated or transmitted by any means, either in whole or in part, without the prior written permission of Guildline Instruments Ltd.

TM4410-A-03

RECEIPT AND INSPECTION

GENERAL

Remove the instrument from its transit case. The instrument was thoroughly tested and inspected before shipment and should be free from any electrical or mechanical damage when received. Nevertheless, you should perform an inspection for physical damage, ensure all items on the packing list are present and test the instrument electrically as soon as possible after receipt. Refer to the warranty card at the front of the manual if any damage or deficiencies are found.

ROUGH HANDLING IN TRANSPORT

A red "Shockwatch" is fixed to the transit case lid. If the indicator section has turned red, this indicates rough handling in transport, but does not necessarily mean that the instrument has been damaged.

A yellow (more sensitive) "Shockwatch" is fitted to the bottom cover of the instrument. If this one has turned red, then the container has received a severe shock, and the transport company and consignor should be notified of the fact. Again, the instrument is not necessarily damaged.

WARRANTY REGISTRATION

The warranty card found at the front of the manual should be completed and returned to Guildline Instruments immediately for registration. The completion and return of this card will ensure that all Field Service Bulletins and Technical Addenda are forwarded to you.

TRANSIT CASE

The transit case for this instrument should be **RETAINED** for transportation when calibration and recertification become due. The transit case should **NOT** be used for other instruments as the specially designed padding inside could be damaged.

- CONTENTS -

<u>SECTION</u>	<u>TITLE</u>	<u>PAGE</u>
1.00.00	INTRODUCTION	2
2.00.00	DESIGN PHILOSOPHY	3
3.00.00	DESIGN IMPLIMENTATION	8
4.00.00	MATERIALS ACCEPTANCE TESTING PROCEDURE	23
5.00.00	OPERATION	24
6.00.00	PERFORMANCE SPECIFICATIONS	34
7.00.00	CERTIFICATION PROCEDURE	36
7.02.00	ADJUSTMENTS	37
8.00.00	STATISTICAL USE OF THE OUTPUTS	39
9.00.00	TROUBLE SHOOTING	69
	INDEX	71

The Guildline 4410 Portable DC Voltage Standard is marketed and supported by Guildline Instruments. It was designed and developed in Australia by STATRONICS with the collaboration of the National Measurement Laboratory (C S I R O Division of Applied Physics)

1.00.00

INTRODUCTION

1.01.01 The Guildline Voltage Standard Model 4410 is designed for instrumentation laboratories which must maintain a knowledge of the absolute magnitude of the Volt to within a few parts per million of the National Standard, and where maintaining standard cell arrays would be impractical or inconvenient.

However, the versatility, ruggedness, low cost, and portability of the 4410 suit it admirably for many less demanding applications.

1.01.02 The ruggedness and ease of use of the 4410 compared with Standard Cells makes it particularly suitable for use in industry, in calibration and repair facilities, and in technical colleges and universities.

1.01.03 Four INDEPENDENT 10V and four INDEPENDENT 1.018V outputs are provided. These are derived from a total of 32 solid state references.

1.01.04 The instrument is designed to be portable and robust, and is provided with its own special Transport Case so that conventional freight methods can be used for re-certification trips to the National Laboratory, or commercial laboratories providing traceable certification. Guildline can provide this service.

1.01.05 The advantages this Electronic Standard has over Electro-chemical Standard Cells are:

Less sensitive to Vibration and Shock
Less sensitive to Accidental Loading
Less sensitive to Thermal Shock
Less sensitive to Ambient Temperature
Portability

1.01.06 Drift and noise performance are similar to temperature controlled Electro-chemical Standard Cells, and compare favorably with other electronic standards currently available.

1.02.01 The manual which follows describes the design philosophy, design implementation, materials acceptance testing procedure, operation, performance specifications and certification procedure.

1.02.02 Attention is drawn to section 8.00.00, STATISTICAL USE OF THE OUTPUTS, by R. Frenkel, of the C.S.I.R.O. Division of Applied Physics (National Measurement Laboratory), Sydney Australia.

2.00.00 DESIGN PHILOSOPHY

2.01.00 GENERAL

2.01.01 There is now a growing acceptance of electronic standards as alternatives to Standard Cell Banks, several instruments being now available. There are also a number of elaborate "Calibrators", or programmable DC Voltage sources which claim stabilities comparable to results achieved with smaller standard cell banks.

While many laboratories will continue to maintain their existing standard cell groups, on which a carefully documented history is available, the electronic standard comes into its own when maintenance of standards at the 10V level is desired.

2.02.02 Some electronic voltage standards have only a single reference. If a change in this reference voltage occurs, such a change can only be detected by crosscomparison with another standard, this often being difficult, impossible, or overlooked.

Calibrators also generally have only a single voltage reference and the additional problem of complex circuitry which makes them less suitable for use as a voltage standard in a laboratory.

The group of four independent voltage references of the Guildline 4410 enable intercomparison within the group leading to a higher degree of confidence, and improved accuracy by utilizing statistical methods. This means that an excellent voltage reference can be maintained by laboratories which may not have the additional Standard Cells or Electronic Standards which would otherwise be required.

2.03.00 The Guildline 4410 Standard was developed with the following objectives:

1. Simplicity and Robustness
2. Stability comparable to Saturated Standard Cells
3. Practicality for smaller laboratories
4. Portability
5. Low Noise
6. Sufficient outputs for statistical error estimation
7. Acceptable for calibration by National Laboratories

ALL THESE OBJECTIVES HAVE BEEN MET.

2.03.01 Simplicity was required for two reasons:

Firstly a larger component count would adversely affect the Mean Time Before Failure, the objective being that the instrument life should extend at least to 20 years.

Secondly, circuit complexity in some areas would make certification time-consuming, costly, or nearly impossible.

In the development of the instrument, it was decided early that NO TRIMMERS WOULD BE USED in the reference circuitry, even for adjusting the last few ppm of the output voltage. User-accessible trimmers are undesirable as far as certification is concerned, and internal trimmers can develop unreliable contacts which could cause sudden changes in the output and generally unpredictable performance.

A concession to the simplicity criterion was made in providing detailed front panel indication of the critical operations of the support electronics for the reference module.

The comprehensive monitoring circuits provided reduce the possibility of temperature cycling the precision components within the oven, and help prevent inadvertent erroneous measurements which could result from operation at too low a battery voltage.

2.03.02 External Battery Operation

Provision for operation on an external battery of the user's choice was considered and rejected, primarily because noise pickup, shielding, and leakage currents from the external battery and its housing could cause measurement errors. A great deal of care was taken in the design of the 4410 to eliminate these possible causes of error.

Furthermore, the battery capacity provided in the 4410 is sufficient for most applications. Loss of battery power for short periods will not adversely affect the performance unless the instrument is also subjected to considerable cold thermal shock. Providing terminals for external battery operation would compromise the performance required by the design.

2.03.03 STABILITY - Reference Elements

All commercially available technologies for "zener" references were evaluated during the development program. High stability point contact zener diodes were discarded early due to poor availability. Integrated circuit "precision" references of the "band-gap" type were evaluated and found to be unsatisfactory for this application.

The reference semiconductor finally selected was from a family of ion-implanted buffered zeners. These are pre-treated and extensively tested then a matched group of eight are used in each reference module.

The Buffer amplifier comprises a precision amplifier for each of the 10V and Buffered Zener outputs, the type being chosen for its specified input offset drift, and general precision performance.

The critical gain setting and division resistors are made to specification, using Evanohm wire from the same spool for each resistor set, and wound in a single layer on selected mica cards. Multiple resistors of similar nominal value are used in order to achieve improved tracking of drift and temperature coefficient. (Currently available film resistors of the best quality were found to have inferior drift characteristics.)

2.03.04 USER FRIENDLY

One of the difficulties with standard cells is that their EMF can be temporarily affected by extremely small charging or discharging currents caused by misuse. The recovery time from this change may vary from hours to months.

The 4410 was designed to retain its integrity even after a SHORT CIRCUIT on the output. The current is limited by a field effect transistor in the supply to the references, and external to the oven. Thus the temperature rise caused by increased dissipation consequential upon a short-circuit load takes place outside the oven, enabling the output to recover to limits very quickly without any temperature related changes in the output.

This feature, the clear indications of operation and the inherent simplicity allow use by non-specialist personnel, or in industrial laboratories without risk to the accuracy of the output.

2.03.05 PORTABILITY

The transfer of the volt between laboratories within a country and between National Laboratories requires a great deal of care when using standard cell enclosures. The most practical types like the Guildline 9154D "Transvolt", which have a built-in battery supply, can be shipped unattended as a "delicate scientific instrument", but will still require up to several days to settle after transportation.

Recently, an increasing number of transfers have taken place using electronic standards. The 4410 has been designed to be compatible with normal pressurized air freight, with road freight treatment, and has the battery capacity to safely maintain oven temperature for 100 hours, sufficient time to enable transfers almost anywhere in the world under normal flight conditions. See section 6.00.00.

A special "transit" switch disables all power consuming parts of the circuit associated with visible monitors and any other non-essential loads. The oven is continuously energised by the battery to minimise drift due to temperature cycling the resistors. The battery may be replaced without de-energising the oven, provided line power is available. The line supply (battery charger) is designed to accommodate most AC line voltages and frequencies.

2.03.06 NOISE

One of the problems most commonly associated with electronic standards is the excessive low frequency noise, compared to standard cells. The main reason for the 8 reference elements used for each output of the 4410 is to minimise this noise by averaging, since the frequency of the noise is too low to filter while maintaining accuracy. High frequency noise generated by the references or the buffer amplifiers is not a problem.

Severe Radio Frequency Interference could cause RF detection both by the Buffer Amplifier, and by instruments connected to the outputs of the 4410. Special precautions have been taken to by-pass and absorb RF energy. High loss ferrite toroidal inductors and low leakage silvered mica capacitors are used at the output terminals. Maximum RFI protection is provided by the use of a metal case, line filter, and a special line transformer.

Isolation of the outputs from line frequency noise can also be a problem with electronic standards. The 4410 uses a specially designed C core line transformer with physically separated primary and secondary windings and multiple electrostatic screens to provide a very high degree of line isolation.

2.03.07 MULTIPLE OUTPUTS

The difficulty with most of the better electronic voltage standards available is that there is only one output. This has serious consequences for transfers and confidence, as described earlier.

There are several methods used throughout the world to disseminate the volt. That which is widely in use is the periodic certification of a laboratory's voltage standard at the National Laboratory, involving the delivery of the standard to the National Laboratory, and a 4 to 6 week period whilst a series of measurements are made against the national standard. For standard cells, the settling time must be added, making quite a long calibration delay. The certified standard is then despatched to the client laboratory. This process has several shortcomings.

Firstly, many laboratories do not have their voltage standard checked more than once a year, and where only one single-output standard is certified, there is always a high risk that the integrity of the instrument can be destroyed by transport effects, and because of the infrequency of certification, the difference may not be detected for a year! A low cost and simple method of overcoming this problem is to maintain a second standard which can be compared with the in-house standard before and after being sent away for calibration.

A second standard would be valuable for laboratories with high cost automated calibrators, particularly if these instruments have a high utilisation factor. The absence of such instruments for certification, provided that the National Laboratory were prepared to perform this operation, could seriously disrupt the calibration program of the laboratory, so an instrument such as the 4410 could be used for periodic certification, compared before and afterwards with the in house calibrator.

The problem of confidence of transfer is overcome by the Guildline 4410 with its 4 separate outputs of 10V and 1.018V, each of which are totally independent with the exception of the support electronics. This means that any perturbation in one output due to whatever cause is simply detected on arrival at the destination. A further advantage is that by comparison of the four outputs, a closer approximation to the national standard can be achieved. This topic is discussed in detail in section 8.00.00

2.03.08 CERTIFICATION

The simplicity of the 4410 implies a high degree of predictability as to its performance. The temperature controlled environment for the references, their very low inherent temperature coefficient, and the facility provided to independently monitor the oven temperature, mean that measurements at different ambient temperatures need not be undertaken to establish a temperature coefficient. These factors, and the excellent noise and leakage performance of the 4410, ensure simple and effective certification.

The 4410 was largely developed within the National Measurement Laboratory, Sydney, Australia, by a team constantly involved in certifying voltage standards, so the parameters of importance to facilitate certification were kept in mind throughout the development program.

3.00.00 DESIGN IMPLEMENTATION

3.01.00 INTRODUCTION

The instrument consists of the following:

Battery Charger	(3.02.00)
Oven Control	(3.03.00)
Support Electronics	(3.04.00)
Four Reference Modules	(3.05.00)

3.01.10 The following page contains the block diagram of the instrument (Fig. 3.01.30), each element of which will be described later in detail.

3.01.11 The battery charger provides sufficient current to charge the battery and drive the other loads. The output is carefully controlled so as to provide optimum charging characteristics and low noise, particularly line line-borne noise.

3.01.12 The oven control module, mounted in the oven, controls the temperature to within 100 mK provided the ambient temperature is between 16°C and 28°C. The Oven is powered directly from the battery, through the battery protection device and under-voltage lockout.

3.01.13 The circuits comprising the support electronics monitor the oven temperature, the battery voltage, the battery charger, the line input, and provide current limiting and pre-regulation to the reference modules.

3.01.14 Each reference module provides 10V (and 1.018V resistively divided from the buffered zeners) by precision amplification from the resistively averaged output of 8 active zeners. Filtering is provided for RF noise only. Thermocouple effects are minimised by careful routing of leads to the reference modules, and by choice of materials. Each reference module has a 0 volt output in common with each of the others, and common input power connections.

The output impedance of the 10V outputs is sufficiently low (about 300 milliohms) that it can be used directly to drive light loads, provided full accuracy is not required. Furthermore, loading the outputs will not adversely affect the long term precision as would be the case with Standard Cells.

BLOCK DIAGRAM

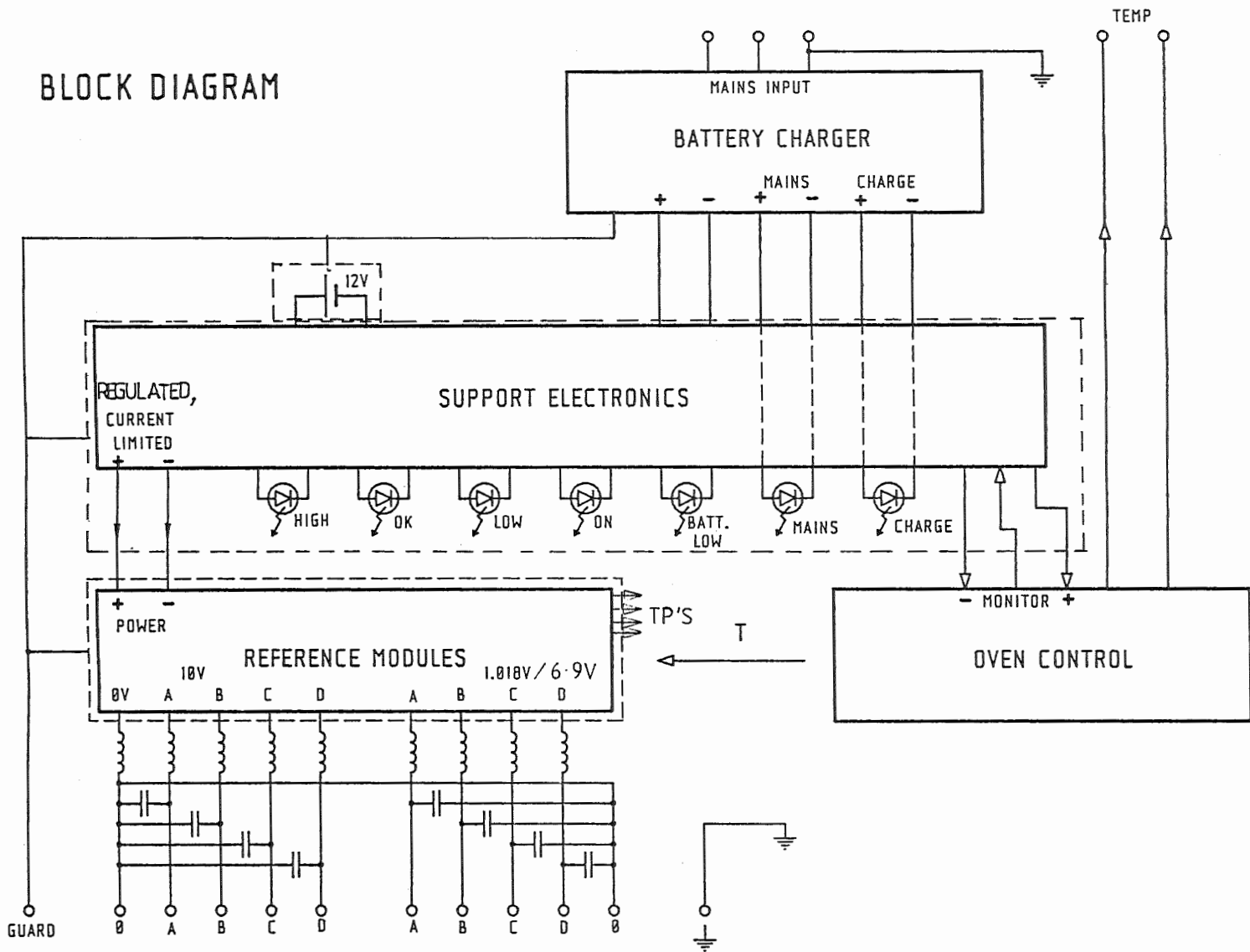

3.01.40 INTERNAL COMPONENT LAYOUT

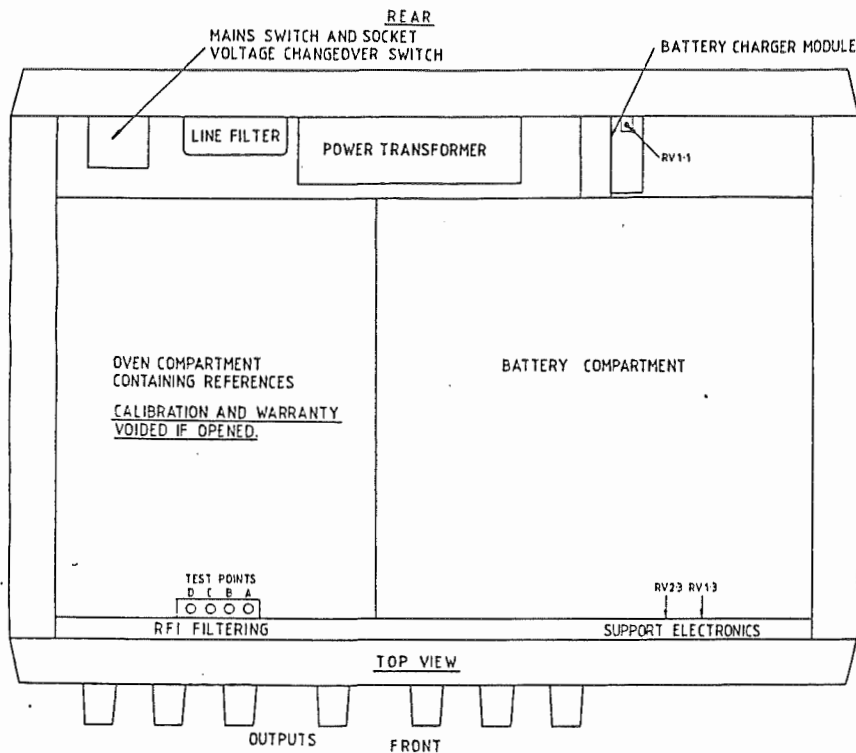

3.01.50 PARTS LIST

MECHANICAL ITEMS, PANEL ASSEMBLY
MODULES, AND PARTS NOT INCLUDED IN MODULE PARTS LISTS.

REFERENCE	DESCRIPTION	MANUFACTURER	REF. / CAT	QUANTITY
	Technical Manual	Guildline	TM4410-A-02	1
	Transport case	Stamford Ind.	Drawing	1
	Case	Schroff	10823-007	1
	Battery cover	T S A	Drawing	1
	Sub-chassis	T S A	Drawing	1
	Oven Cover	T S A	Drawing	1
	Front panel	T S A	Drawing	1
	Back panel	T S A	Drawing	1
	Oven enclosure	Midax	Drawing	1
	Batteries Hitachi	HP 10-6		2
	Line cord	Belden		1
	Terminal, Red	Trewin	T474 AU/CU/S	8
	Term., Black	Trewin	T474 AU/CU/S	2
	Term., Green	Trewin	T474 AU/CU/S	1
	Term., Blue	Trewin	T474 AU/CU/S	1
	L5.1-L5.12 Toroid Core	Neosid	28-512-27	9
	C5.1-C5.12 330pF Sil. Mic	CDE		8

3.02.00 BATTERY CHARGER

3.02.10 CIRCUIT DESCRIPTION

3.02.11 The input receptacle and voltage selector S2.1 also includes the power switch S1.1 and input line fuse F1.1. The line filter FX1.1 is provided to reduce the effects of line-borne Radio Frequency Interference.

3.02.12 Transformer TX1.1 has less than 0.5 pF Primary to Secondary capacitance by virtue of multiple shielding to minimise coupling to the line, and works at low flux densities to minimise AC fields. Series or parallel connection of the primary is selected by S2.1 so as to allow operation on 240V or 120V AC nominal lines.

The secondary voltage and filter capacitor C1.1 have been selected to provide the desired output for the full range of line input voltages specified.

3.02.13 The three-terminal integrated circuit voltage regulator IC1.1 controls the voltage to the battery. The voltage is set by RV1.1 to that which is recommended to float charge the battery. Note under ADJUSTMENTS, section 7.02.02, PAGE 37, the procedure for this adjustment.

3.02.14 Transistor Q1.1 current limits the output to 400 mA, which is adequate to provide the oven worst-case power requirement at 16 °C ambient, plus the requirement of the reference modules, and 150 mA to charge the battery. With the oven "off" (i.e. when ambient exceeds 28°C), the current of 400 mA is within the limits for charge current for the batteries specified.

3.02.15 Resistor R2.1 from the un-regulated DC provides the indication of power on the front panel through diode LED7.3 Diode LED6.3 is in the collector circuit of Q1.1, and indicates rapid charge. (When the battery is low and power is applied, the charger will current-limit until the battery voltage rises. Whilst in current limit, current flows through LED6.3 and Q1.1). In the event of an open-circuit in the LED 6.3 circuit, back-up protection is provided by the regulator integrated circuit.

3.02.16 Diode D1.1 is for transient protection, and D2.1 prevents leakage of current back through the charger while the instrument is running on battery power.

3.02.20 SCHEMATIC, BATTERY CHARGER

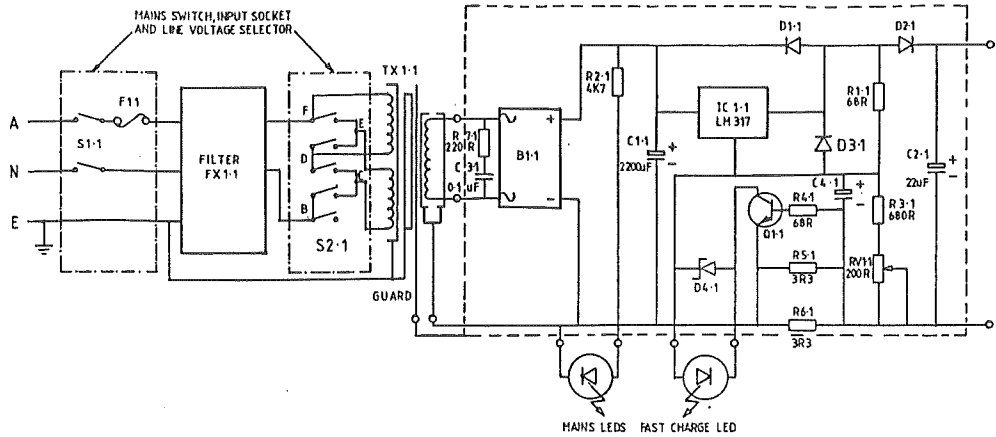

3.02.30 CIRCUIT BOARD LAYOUT, BATTERY CHARGER

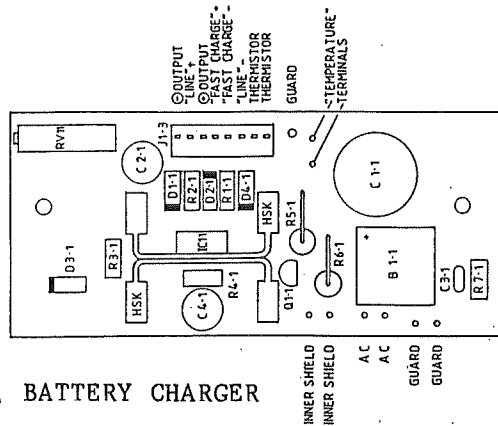

3.02.40 PARTS LIST, BATTERY CHARGER

REFERENCE	DESCRIPTION	MANUFACTURER	REF. / CAT.	QUANTITY
S1.1, S2.1,				
F1.1	Input Switch etc.,		F2MPM2432M	1
FX1.1	Line filter	Potter	620CIV	1
TX1.1	Transformer Board	Harbuch	PT309A 422	1 1

All resistors 1% 1/4 watt metal film unless otherwise specified.

R4.1, 1.1	68R			2
R2.1	4K7			1
R3.1	680R			1
R5.1, 6.1	2R5-2W			2
R7.1	220R			1
Q1.1	BC549			1
RV1.1	200R	Spectrol	43P	1
B1.1	BR64	Gen Inst	BR64	1
C1.1	2200uF 35V	Philips		1
C2.1, 4.1	15uF 20V			2
C3.1	0.1uF Mono			1
IC1.1	LM317T	National SC	LM317T	1
D1.1, 2.1, 3.1	1N5060	GE	1N5060	3
J1.3	Base & post assy	Solterco	B8P-SHF-1AA	1
D4.1	9V Zener		9V1	1
HSK	Heat sink	Redpoint		2

3.03.00 OVEN CONTROL

3.03.10 CIRCUIT DESCRIPTION

Thermistor RT1.2 is connected in a bridge configuration with R1.2, R2.2 and R8.2, with IC1.2 providing a stable nominally 6.9V source. The amplifier IC2.2 provides a voltage gain of 1700, and the output, through R7.2, drives IC3.2, which performs the heating function.

The output of the difference amplifier is taken through R9.2 to the support electronics module where the magnitude of the voltage is monitored by a threshold detector to drive the oven monitoring LED's.

An independent thermistor is provided, RT2.2, which is terminated directly to the sockets on the rear panel, for independent monitoring of the oven temperature.

The network R6.2, R10.2, R4.2 provides a small correction current to compensate changes in battery voltage.

The overall temperature gain is greater than 100, giving temperature control, over the defined limits for ambient temperature, of 120 mK.

C1.2 and C2.2 provide noise suppression and ensure high frequency stability.

The two emitter resistors in IC3.2 go open circuit in the unlikely event of a short C-E failure of IC3.2.

No correction network is necessary to ensure low frequency stability to thermal load steps. The thermal step load response indicates unconditional stability.

IC3.2 and the thermistors are mounted close together in the heart of the cast aluminium oven enclosure.

Special mounting techniques are used to ensure low leakage from the outputs to guard, since the oven control is connected to the outputs through the common power source, and the oven enclosure is connected to guard.

3.03.20 OVEN CONTROL - SCHEMATIC

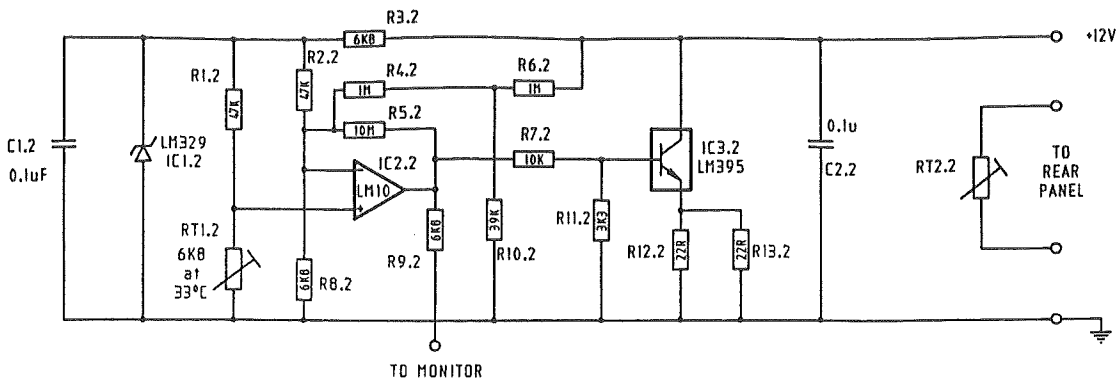

3.03.30 OVEN CONTROL - CIRCUIT BOARD LAYOUT

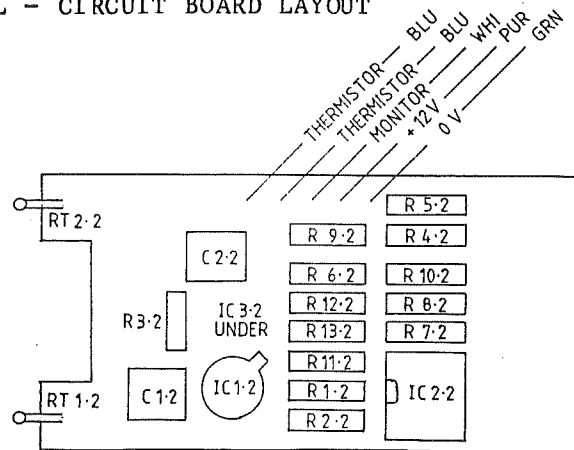

3.03.40 OVEN CONTROL - PARTS LIST

REFERENCE	DESCRIPTION	MANUFACTURER	REF. / CAT.	QUANTITY
	Board	Emired	Drawing 462	1

All resistors 1% 1/4 watt metal film unless otherwise specified.

R1.2, 2.2	47K			2
R4.2, 6.2	1M			2
R8.2, 3.2	6K8			3
R9.2	6K8			1
R5.2	10M 5% carbon			1
R7.2	10K			1
R10.2	39K			1
R11.2	3K3			1
R12.2 13.2	22R			2
RT1.2, 2.2	Thermistor	Radiospares	151-237	2
IC1.2	Reference	National SC	LM329AH	1
IC2.2	LM10CN	National SC	LM10CN	1
IC3.2	LM395T	National SC	LM395T	1
C1.2, 2.2	0.1uF 50V	Monolithic		2

- 3.04.00 SUPPORT ELECTRONICS
- 3.04.10 CIRCUIT DESCRIPTION
- 3.04.11 Oven Monitor

The two amplifiers IC1.3A and IC1.3B are used as comparators to monitor the voltage at the output of the oven temperature control amplifier, IC2.2 which is a voltage proportional to the temperature error. These two detectors drive diodes LED1.3 to LED3.3, which indicate the oven temperature control mode. A temperature error of approximately 100 mK will show that the temperature is no longer under control.

- 3.04.12 Battery Monitor

IC3.3A compares the voltage from the battery, divided through R12.3, R11.3, and RV1.3 with the reference voltage developed across IC6.3 and D4.3. The output of IC3.3A drives the low energy flasher arrangement of IC4.3, feeding LED4.3. RV1.3 sets the threshold voltage at which indication of low battery voltage is given. It is factory set at 11.7V. LED6.3 is driven from the charger module and indicates fast charge. See paragraph 3.01.15.

- 3.04.13 Regulator

IC2.3 and Q1.3 form a low drop-out current-limited pre-regulator for the reference modules to keep the power dissipation in the oven constant for changing battery voltage and to ensure a safety margin for the power supply rejection ratio of the reference buffers. Voltage control is by IC2.3A, IC5.3 being the reference, feedback through R20.3, R21.3 and RV2.3, which is pre-set to 11.6V output. The current through R9.3 is monitored by IC 2.3B, the reference being derived from IC6.3 through divider R17.3, R18.3, via R6.3, hysteresis being provided by R16.3. The output of IC2.3B clamps the output of IC2.3A (driving FET Q1.3) through D3.3 and R8.3. This provides a current-limited power source to the Reference modules of a magnitude low enough for any one module to safely sink.

- 3.04.14 Transit Switch

The transit switch, S1.3, disconnects all loads not essential for the operation of the instrument - i.e. all indicators with the exception of the low battery monitor, so as to minimise battery drain.

- 3.04.15 Other Indicators

The battery fast charge indicator, LED 6.3, and the power indicator, LEDs 7.3/8.3, are wired from the battery charger module.

3.04.16 Battery Protection

RT1.3 is a positive temperature coefficient thermistor with such a steep curve that it latches out when excessive current flows. This device protects the battery from excessive currents which could cause damage. Should the device operate, both battery and line power must be disconnected in order to reset the device. If this operation is completed within 30 minutes, integrity is not lost, due to the large thermal inertia of the oven, however a restoration time of 90 minutes must be allowed for the oven and its components to settle to exact temperature.

Diode D5.3 protects the electronics from reverse battery connection by forcing the operation of RT1.3 should the battery be connected reversed.

IC3.3B and Q2.3 form an under-voltage lockout circuit so that the relatively high power consumption of the oven heater and control is disconnected when the battery voltage drops below about 11.2V. This prevents excessive depth of battery discharge, extending the operational life and speeding up the re-charging cycle.

3.04.17 Battery Replacement

Two 7 Amp-hour capacity, 12 Volt sealed recombination electrolyte batteries are fitted, connected in parallel. This configuration provides the maximum battery capacity which can be readily accommodated and simply charged.

When replacing batteries, the replacements should first be cycled, tested, and fully charged, before installing in the instrument. ALWAYS replace batteries with fully charged units and ALWAYS replace both batteries.

The batteries fitted are rated for 5 years operational life under the conditions applying in the 4410. It is suggested, however, that they be replaced after three years, so as to ensure the availability of maximum battery capacity.

Batteries may be replaced "hot" - with the instrument powered from line power - without disturbing the reference circuits and calibration status.

3.04.20 SUPPORT ELECTRONICS SCHEMATIC

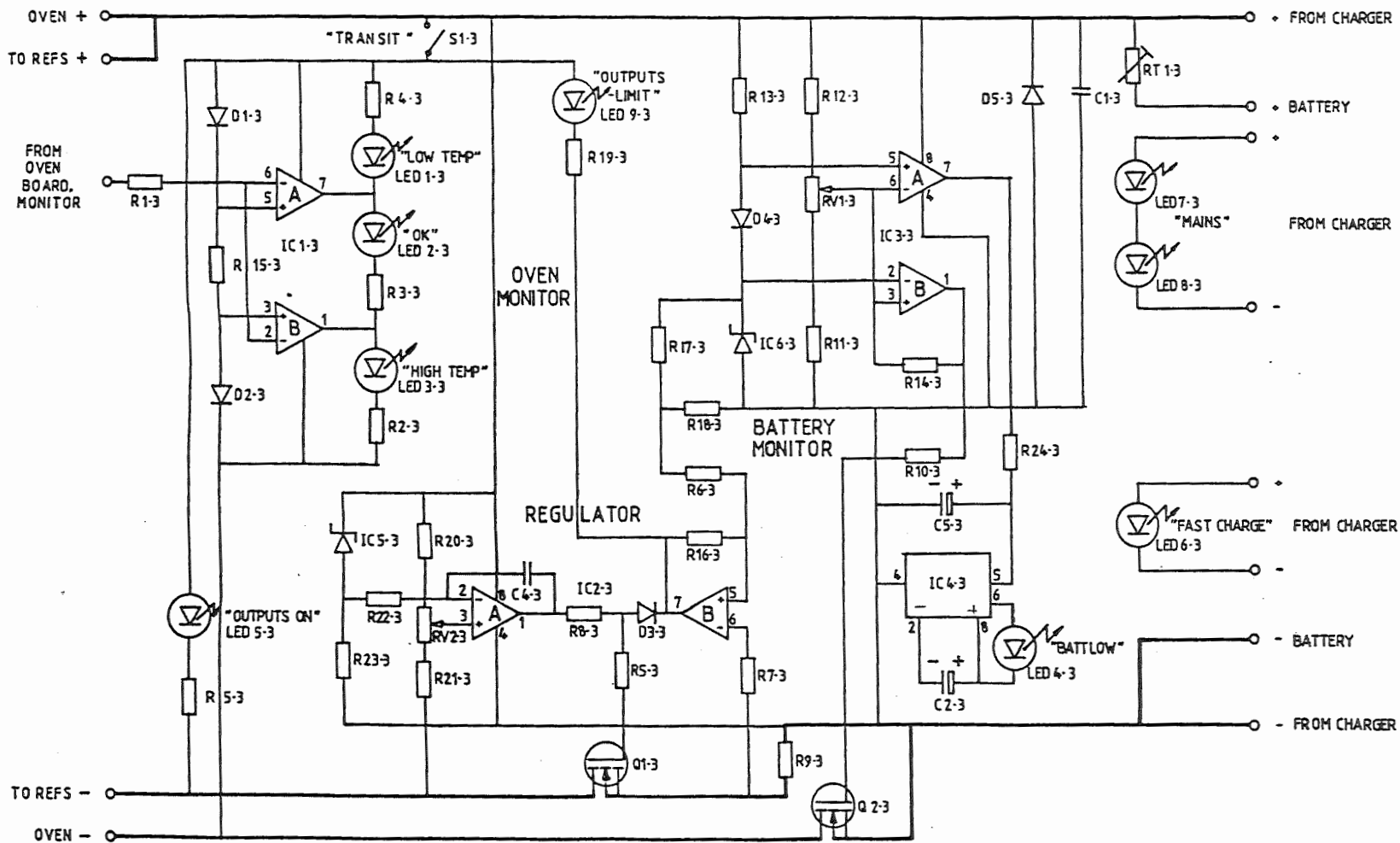

3.04.30 SUPPORT ELECTRONICS
CIRCUIT BOARD LAYOUT

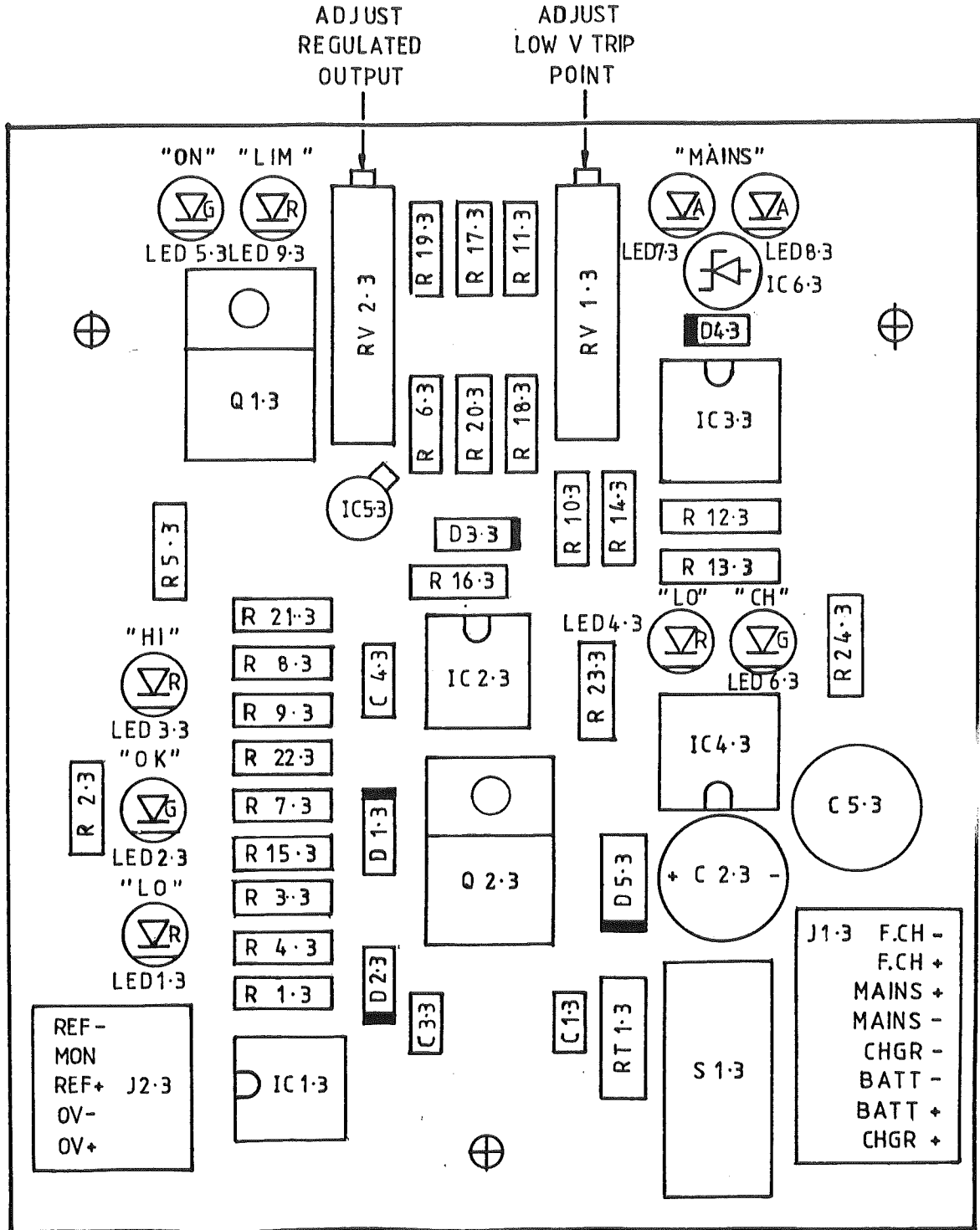

3.04.40 SUPPORT ELECTRONICS
PARTS LIST

REFERENCE	DESCRIPTION	MANUFACTURER	REF. / CAT.	QUANTITY
	Board		Drawing 452	1
All resistors 1% 1/4 watt metal film unless otherwise specified.				
R1.3	5K6			1
R2, 3, 4.3	2K2			3
R13,19.3	2K2			2
D4.3	11DQ04			1
R5,6,7.3	6K8			3
R10,17,23	6K8			3
R8,11,20.3	15K			3
R9.3	0.9 Ω			1
R12,21.3	10K			2
R14,16.3	10M (5% carbon film)			2
R15.3	47K			1
R18.3	68R			1
R22.3	1K1			1
R24.3	22K			1
D1,2,3	1N4148			3
D5.3	1N5062			1
IC1,2,3.3	Dual Amplifier	National SC	LM358CN	3
IC4.3	Flasher	National SC	LM3909	1
IC5,6.3	Reference	National SC	LM329AH	2
RT1.3	Polyswitch	Raychem	RBE085A	1
C1,3,4.3	0.1 μ F	Monolithic		3
C2,5.3	220 μ F20V	Philips		2
Q1,2.3	N-FET	Int'l Rect'r	IRF530	2
LED1,3,4,9	red	Hewlett Pack.	HLMP3950	4
LED2,5,6.3	green	Hewlett Pack.	HLMP3750	3
LED7,8.3	yellow	Hewlett Pack.	HLMP3850	2
LED Diffuser		Laserex	Drawing	4
J1.3	Plug	Solterco	BS8P-SHF-1AA	1
J2.3	Plug	Solterco	BS5P-SHF-1AA	1
S1.3	Switch	C & K	1612	1
RV1, 2.3	Trimpot 1K			2

3.05.00 REFERENCE MODULE

3.05.10 CIRCUIT DESCRIPTION

3.05.11 General

IC1.4 and Q1.4 form an ultra-low drift, low noise amplifier, described in 3.05.12. The output of this amplifier is connected directly to the 10V output terminals, through a simple RF filter network. It also drives resistors R1.4 to R8.4 which provide the operating current for the "zeners", IC3.4 to IC10.4. This "boot-strap" arrangement provides excellent power supply voltage rejection. IC2.4 is a precision unity gain buffer which is divided resistively for the 1.018V output.

3.05.12 Amplifiers

The 10V amplifier drop-out voltage (the supply voltage below which the output is no longer controlled) is 100% tested to be no greater than 11.4V. The low voltage alarm (support electronics) is set at 11.6V. Whilst the output voltage may not be under control if the low battery voltage indicator is flashing, provided that the oven control indicators show correct temperature, line voltage can be applied to restore the battery voltage, and the output used within a few minutes of the low voltage lamp extinguishing.

For a supply voltage variation of from 11.6V to 14V, the limits which can be experienced by the pre-regulator without warnings to the user, the output varies by less than 0.1 ppm.

The operational amplifiers have been selected for low noise and low offset voltage, and particularly low offset voltage drift with time. The gain of the 10V amplifier is defined by the resistor network R9.4, R10.4, R11.4 and R12.4. R12.4 is determined by substitution to achieve 10.0000V output, within a few hundred microvolts, for the initial value. The prescribed resistor is then manufactured to order.

The transistor Q1.4 is included to provide sufficient drive current for the 1mA for each of the reference elements, and to protect the amplifier IC1.4 from thermal shocks caused by inadvertent overloading of the outputs. The buffer amplifier is unconditionally stable for all passive loading conditions.

3.05.13 Reference Mixing

Resistors R13.4 to R20.4 average the voltage of the 8 "zeners", IC3.4 to IC10.4, applying this to the non-inverting inputs of both amplifiers, IC1.4 and IC2.4. Averaging the 8 zener outputs reduces zener noise by a factor of about 3.

3.05.14 Divider

The resistor network formed by R23.4 to R28.4 are the divider which provides 1.018V from the unity buffered zener voltage. The value of R28.4 is selected on test and the resistor then manufactured to order.

3.05.15 Start-up

The circuit starts reliably on application of power. Initially the input voltages to the amplifiers are outside the input common mode range for proper operation. The small voltage which appears on the output of the amplifier is sufficient to bring the non-inverting input positive, to be further amplified and thus pull up the output into the controlled range.

3.05.20 REFERENCE MODULE SCHEMATIC

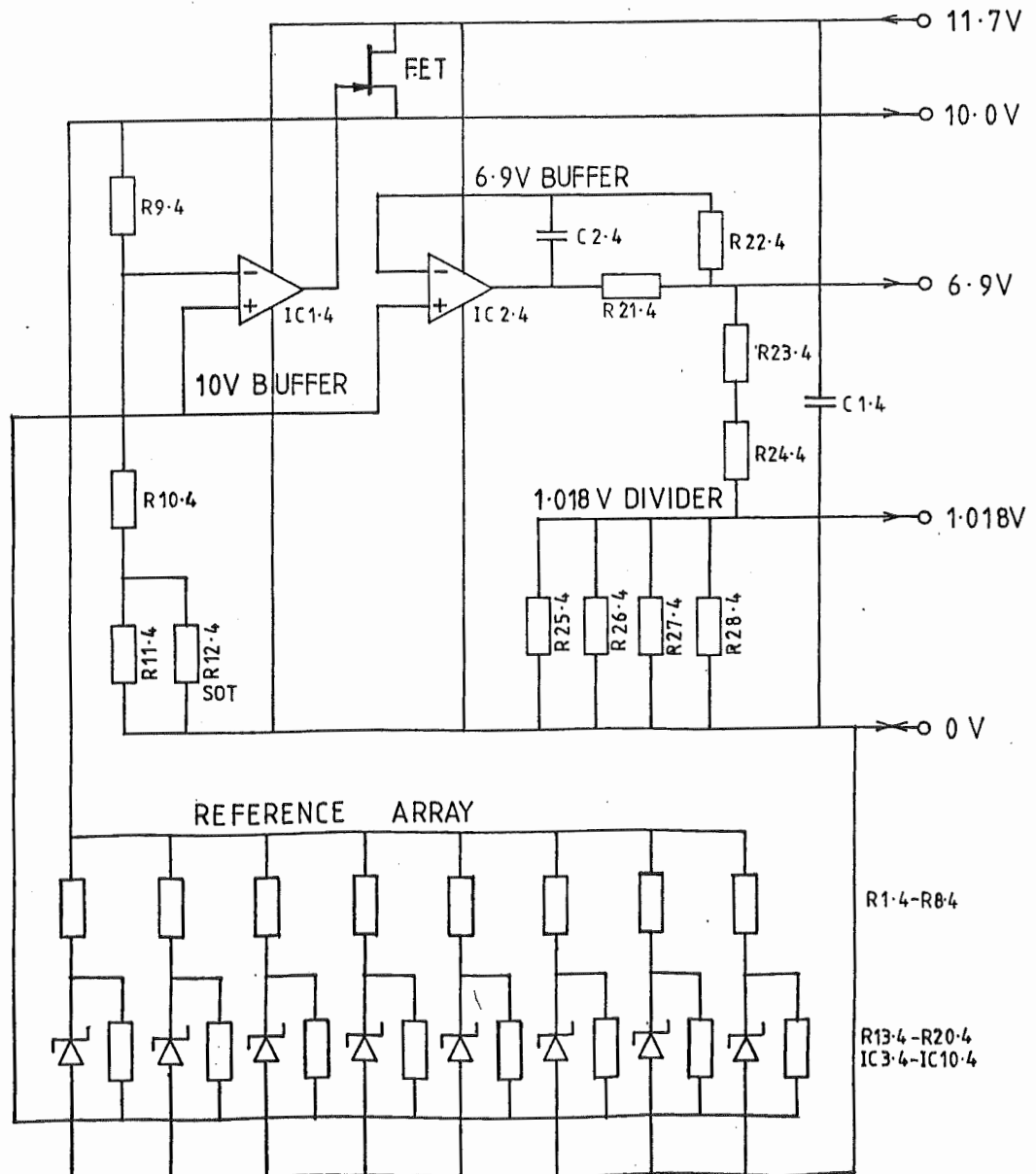

3.05.30 REFERENCE MODULE
PARTS LIST

Note: The parts in the reference module are not available as spares. Each reference module contains selected-on-test parts which are dependent on the other parts. Replacing any one of these parts will entail complete re-calibration and possible degradation in performance. Furthermore, all the components in the module undergo special pre-treatments which cannot be duplicated without special equipment.

NOTE THAT IF THE OVEN ENCLOSURE IS OPENED, THE INSTRUMENT WARRANTY IS INVALIDATED.

Each module has its own serial number, and we maintain detailed records as to select-on-test values, and tested initial results. Any module found at any time to be faulty, from whatever cause, should be returned for examination, still fitted in the instrument.

REFERENCE	DESCRIPTION
J1B.4-J8B	Mother board Plug
All resistors 1% 1/4W metal film unless otherwise specified.	
R31-62.4	10R
J1A.4-2A.4	Daughter board Plug
R1-R8.4	2K7 resistor network
R9.4	3K00 0.05%
R23-R25.4	3K00 0.05%
R10-R11.4	3K50 0.05%
R26-R27.4	3K50 0.05%
R12, 28.4	S.O.T 0.03%
R13-R20.4	3K3 Resistor network
IC1.4-2.4	Amplifier
IC3.4-10.4	Reference
Q1.4	FET PN4391
C1.4-2.4	0.1uF Mono
R21.4	2K2
R22.4	200R

4.00.00 MATERIALS ACCEPTANCE TESTING PROCEDURE

The reference zeners are tested 100% after ageing for temperature coefficient, drift, low frequency noise and output voltage. Only reference elements of the same batch are included in any one reference module.

All other components used in the reference module are tested for key performance parameters, mounted and cleaned.

Precision resistors are tested for resistance before and after annealing and are coded as to day of manufacture and reel number of wire. These identifications are marked on containers rather than resistor bodies, as markings on the body of the resistors were found to adversely affect temperature cycling performance.

Assembled reference modules are then tested for noise, temperature coefficient, drop-out voltage and short-term drift. Each reference module is identified with a serial number, as is each instrument. The serial numbers of each reference module fitted are recorded against the instrument serial number.

All active components external to the oven are visually inspected, then all completed modules are tested under 50% overload conditions, at maximum ambient temperature.

Terminals are 100% visually inspected, and batch tested for leakage before and after assembly.

Transformers are 100% tested for finish, primary magnetising current, leakage resistance, inter-winding and shield capacitance. Samples are submitted to 95% humidity and re-tested for leakage resistance.

Mechanical components are subjected to 100% visual inspection.

Samples of each coil of teflon wire are inspected for dimensional accuracy and finish, and the total resistance of each fresh reel is measured prior to use.

Samples of each printed circuit batch, in the case of the reference module boards and the mother board 20% samples, are inspected for dimensional accuracy, chemical contamination, and leakage resistance.

5.00.00 OPERATION

5.01.00 PANEL CONTROLS AND INDICATORS

5.01.10 OVEN STATUS

The three front panel LED's indicate the condition of the oven. In normal use, the green OK LED should be on. A red light for oven HI or LO indicates EITHER that;

5.01.11 The oven has not yet settled after being energised. As the oven is permanently connected, it can only be de-energised by either the battery being discharged, or the battery leads being disconnected inside the instrument. The oven takes less than 120 minutes to settle with a 20°C ambient temperature, less with a higher and more with a lower ambient temperature, OR:

5.01.12 The ambient temperature is either too high or too low for correct operation of the oven. The limits for the control range of the oven are 16°C to 28°C, OR:

5.01.13 A fault condition, OR:

5.01.14 Very low battery voltage.

5.01.20 TRANSIT SWITCH

The TRANSIT switch disables all indicators except LOW BATTERY.

There are three possible methods of operation of the 4410 when it is transported for use in another location or sent to a standards laboratory for certification.

5.01.21 For short trips up to a day, the unit can be carried under battery power without the use of the travelling case. Under these conditions, the power consumption is dependent largely on the ambient temperature.

Care should be taken that the limits for the oven control range of ambient temperature are not exceeded for more than a few minutes. Whilst there is sufficient thermal inertia to cope with short duration excursions outside the oven control range, prolonged periods will cause a gradual change in the oven temperature with the possibility of temperature cycling the precision resistors. Leaving the instrument on the seat of a car in the summer sun is an example of where excessive temperature rise may occur. See 5.01.23.

5.01.22 For longer, unattended trips, the 4410 is placed in its travelling case to improve insulation, however the "TRANSIT" switch should be depressed, disconnecting all non-essential loads so as to conserve battery capacity. In this condition, the only indicator lit is the battery condition indicator.

Battery operation in this mode can be considerably extended if the unit is operated in its travelling case for several hours while still connected to the line. This enables line power rather than battery capacity to be used to lift the temperature of the entire instrument to a temperature which is dependent on the thermal resistance from the oven to the outside of the travelling case.

- 5.01.23 For very long trips, possible airport delays etc., the unit is transported as in (5.01.22) above. The battery may eventually discharge at a time dependent on the ambient temperature. However, the depth of discharge is limited, since the major power consuming loads are disconnected when the battery voltage falls to about 10.8 volts, so the battery recovers fairly quickly when line power is applied. The instrument is further protected from thermal shock by the transit case.

The reference diodes in the 4410 show only a very small change when not powered for a few days. If they are not powered for longer, then the recovery time to normal output is roughly three times the period left un-powered. This is the effect of the accelerated ageing process wearing off, and is believed to diminish over a protracted period of powered operation of the order of 5 years. The resistors show excellent tracking under these conditions of gentle temperature cycling, however for confidence, a comparison is always a wise precaution after temperature cycling is known to have occurred. See 5.01.21.

5.01.30 **LINE INDICATOR**

This shows that line power is applied and the line switch (on the rear panel) is ON. The chassis of the instrument and the front panel terminal GROUND are connected to the line ground.

5.01.30 **OUTPUTS INDICATOR**

When the outputs indicator shows green, and no red LED's are visible on the panel, then measurements may be made from the output terminals, providing that there has been no recent disturbance such as the oven temperature being out of control, which would require a settling time.

A red light visible in the OUTPUTS indicator shows that an output is either overloaded or shorted. After correcting the overload condition, a short settling time of the order of 5 minutes should be allowed, provided the oven monitor indicates OK.

5.01.40 BATTERY STATUS INDICATORS

On application of power, the FAST CHARGE green LED will illuminate dimly, indicating that the charger is in the current limited mode. If the battery is in a reasonable state of charge, this LED will extinguish quickly, indicating that the battery terminal voltage is approaching 13.8 volts. If the battery voltage is initially low upon application of power, the LED will illuminate brightly, and gradually fade as the battery voltage rises.

The LOW indicator threshold is set at 11.7 volts. The red LED will start to flash as the battery voltage drops to this level, however as the buffer amplifiers drop out 100 to 200mV lower, there is still several minutes operation with full performance. This feature is provided to allow measurements to be completed or power to be re-applied before the need to wait for any settling time.

As the battery voltage further falls, the output voltages will drop considerably, making further measurements impossible until power is applied. Within a few minutes of application of power, measurements can be resumed, however if the battery voltage has dropped too low, oven control could have been lost, this being indicated by the oven monitor lights. In this case follow the instructions under the heading of OVEN STATUS, 5.01.10.

5.01.50 OUTPUT TERMINALS

Maintenance: Specially manufactured gold plated copper terminals are fitted, with custom moulded low leakage insulators. The leakage performance of the instrument can be impaired by poor handling techniques and dirt on the front panel. The panel may be wiped with a clean, dry, lint-free cloth, or for more stubborn grime, laboratory alcohol may be used sparingly.

Do not over-tighten terminals. Do not use anything but best quality spring 4mm plugs - preferably gold plated beryllium copper to reduce thermal emf's, or clean, unplated pure copper wire.

As can be seen by the schematic of the reference module, 3.05.20, the 1.018V output is resistively divided from the buffered output of the same reference array which drives the 10V output. So 1.018V output "A" is that which is related to 10V output "A", etc.

The 10V outputs are intended to be the primary references. The 1.018V outputs are provided to facilitate comparison with standard cell banks.

5.01.60 LINE VOLTAGE CHANGEOVER SWITCH

The 4410 will operate on 110/120V nominal line voltage or 220/240V. A switch is provided under a cover plate on the line input receptacle on the back panel. The window in the cover plate indicates to which input voltage the 4410 is set.

To change the setting, remove the line cord and open the cover plate by prising the edge nearest the power switch, above the lettering, using a small screwdriver. Remove the tumbler so revealed and turn so the desired voltage range is showing when re-inserted. Close the cover and replace the line cord.

5.01.70 POWER SWITCH

The power switch is located on the rear panel, just above the power inlet. Power is ON when the part of the rocker switch labelled "I" is depressed.

5.01.80 LINE FUSE

The line fuse is accessed by removing the power cord from the input socket and lifting the cover as described in "LINE VOLTAGE CHANGEOVER SWITCH" above. Two drawers marked with white arrows may be removed to replace or inspect the fuses, one of which is a spare.

Do not use fuses rated at greater than 1A or less than 0.25A. Use normal speed or slow blow fuses with a 250V rating.

The input fuse can fail due to the following causes:

- 1) A fault in the transformer or battery charger.
- 2) The wrong line supply for the input setting.
- 3) A very substantial line supply transient.
- 4) A fault in the line filter.

5.01.90 **TEMP** - TEMPERATURE MONITOR, EXTERNAL

Two 4mm sockets on the rear panel, connected directly to a thermistor in the oven provide independent monitoring of the oven temperature. If RF interference is expected to be a problem, do not to use these when precision measurements are being made. They are a check on correct oven operation only.

To minimise self-heating of the internal thermistor, a digital ohm-meter or bridge should be used which will not pass more than 100 μ A through the thermistor. The resistance of the thermistor at stabilised oven temperature is provided in the annexed initial certification.

**** No more than 1mA or 10V should be applied to these terminals as PERMANENT DAMAGE may occur.**

5.02.10 USE OF THE 4410 FOR CALIBRATING VOLTAGE MEASUREMENT INSTRUMENT SETS

Fig. 1 shows a typical 10 Volt calibrating setup using a Kelvin Varley Divider (KVD) and a 10V or 11V supply. The KVD dials are set to the value shown on a calibration report for the 4410 10V output used, and the KVD supply is adjusted for a null on the null detector. For dividers which have a 10V full scale rather than 11 volts, it may be necessary to read a difference on the null detector if the 4410 output is slightly greater than 10 volts.

Fig. 2 shows a 1.018 volt output of a 4410 being used to standardise a potentiometer. The certified value of the 4410 output is set on the potentiometer dials and the current control is adjusted for a null on the galvanometer or null detector. Alternatively, the 4410 can be used as a replacement for the standardising cell used with the potentiometer. This latter method is generally more convenient but not as accurate.

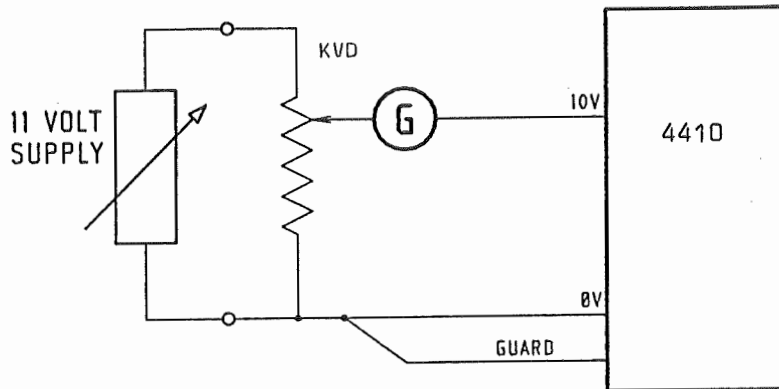

FIGURE 1

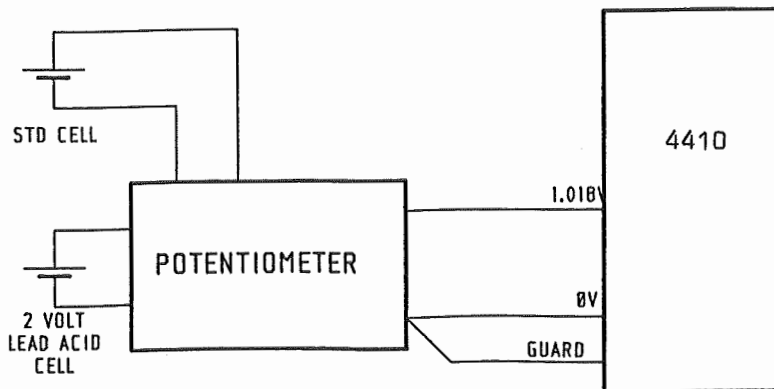

FIGURE 2

5.02.11 USE OF THE 4410 TO STABILISE CURRENT SOURCE AND STANDARDISE POTENTIOMETER

The 4410 is also ideal for use with the Guildline 9930 and 9936 measurement systems when used to stabilise the current source, model 9936. A 4410 could also be used to standardise the potentiometer, model 9935. Figure 2A shows the suggested arrangement.

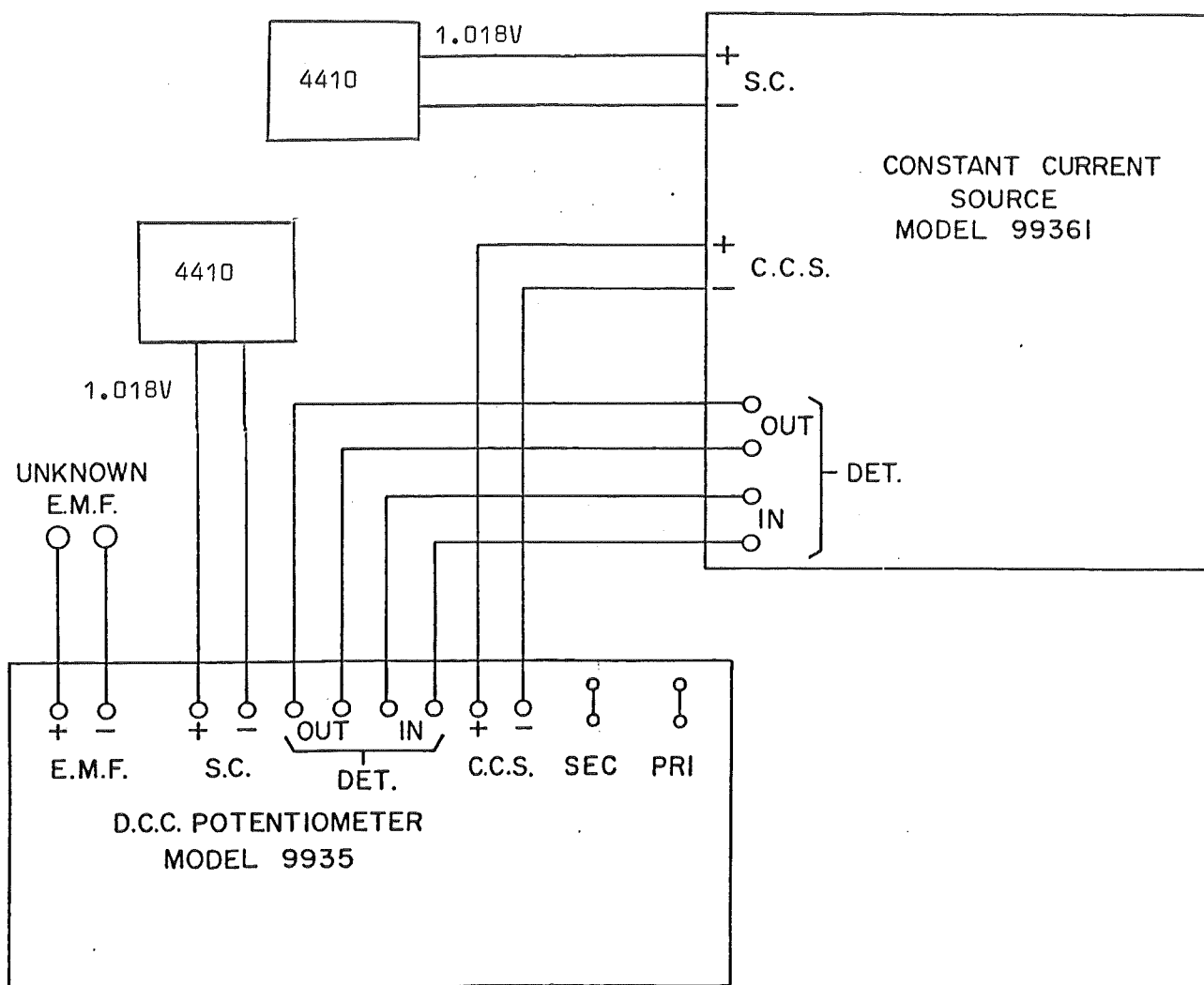

FIGURE 2A

5.02.20 INTERCONNECTIONS AND SHIELDING

Connecting wires should be of clean untinned copper wire to reduce thermal emf's.

Electrostatic shielding is generally desirable in the most precise work in order to avoid effects caused by electrostatic charges. For example, an operator wearing synthetic soled shoes on a vinyl floor may cause spurious deflections on a null detector in an unshielded setup. Also shielding will reduce AC pickup from the line, computer hash, and RF interference. A large AC pickup can overload null detectors and produce large errors when standard cells are used, as the cells tend to rectify AC signals and produce a DC bias.

A possible shielded setup is shown in Fig. 3. A coaxial cable with an untinned copper inner conductor is suitable for this purpose.

Magnetic field pickup in the leads can also be a problem. Ordinary shielded cable has little effect with line frequency magnetic fields. Satisfactory results are normally achieved by avoiding lead proximity to transformers etc., and by keeping the area of any loops to a minimum by running leads together. This is illustrated in Fig. 4. Twin shielded cable is convenient for this application as it minimises both electrostatic and magnetic pickup.

Guildline SCW wire is recommended for this purpose.

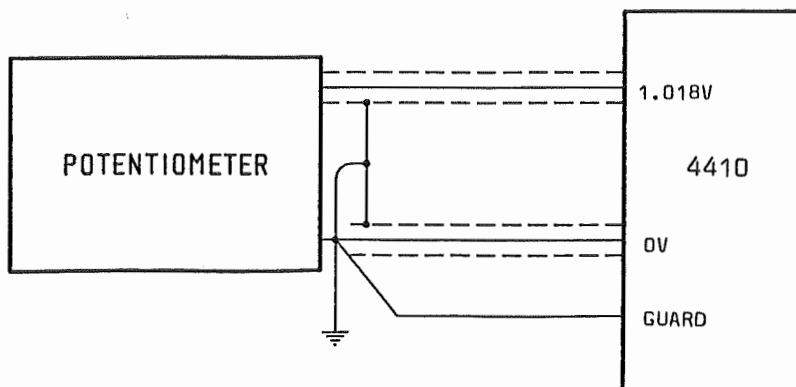

FIGURE 3

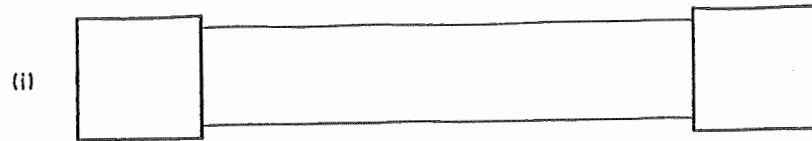
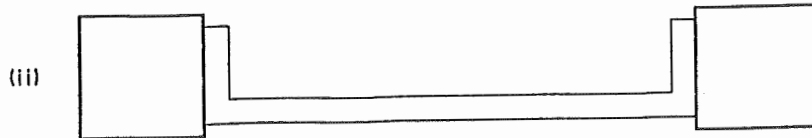

FIGURE 4



Area enclosed by connecting leads is much smaller in (ii) than (i).
Twin shield leads provide both reduced magnetic and electrostatic pickup

5.02.30 COMPARISON OF THE 4410 WITH STANDARD CELLS

The 4410 can be compared with standard cells by two methods:

5.02.31 COMPARISON BY SUBSTITUTION

In this method, the cell or group of cells and the 4410 are connected alternately to the potentiometer. Fig. 5 shows a group of 9 or 10 cells being compared with a 10V output of the 4410 using a KVD setup. In general this method is simple but may be limited by the resolution and accuracy of the KVD or potentiometer used. Comparison of a 1.018 volt output of a 4410 with a single cell is similar to the above although more care must be exercised to avoid thermal emf problems at this lower voltage level. Reversing the connecting leads and the potentiometer supply can be used to eliminate the thermal EMF.

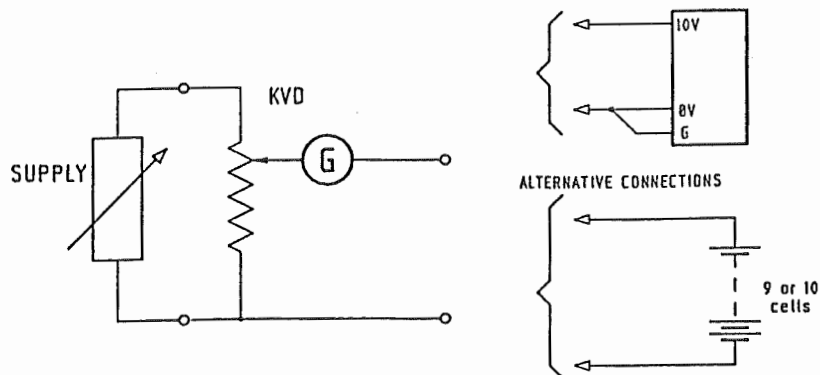

FIGURE 5

5.02.32 COMPARISON BY BACK TO BACK MEASUREMENTS

This method provides the highest accuracy since only small differences are being measured, and it is possible to compare the 1.018 volt outputs of the 4410 with a standard cell to, say, one part in 10^7 with only modest equipment.

While a conventional potentiometer may be used to measure the difference voltage, changing switch emf's and resolution may be the limiting factors. If a very high quality potentiometer such as the Guildline 9930 or 9936 Direct Current Comparator is used, the effects of thermal emf's can be reduced to less than 10nV.

Another solution is to use a LINDECK potentiometer, in which all switching occurs at higher voltage levels and is divided by two resistors. No switching occurs in the output circuit of the potentiometer and the resistive divider allows the measured EMF to be read on a digital voltmeter, say, at a magnified level. Fig. 6 shows a possible circuit. Thermal EMF's in this circuit are fairly stable and can be eliminated by reversal.

Back to back measurements at a 10 volt level can usually be made directly with a KVD since thermal emf's are less of a problem at this high level. For example, a 5 μ V thermal emf is a 5 in 10^6 error at the 1.018 volt level but only 5 in 10^7 at the 10V level.

AC and DC leakages can be more of a problem in back to back measurements because one of the devices being measured may have leakage currents shunted across it because of the series connections. Fig. 7 shows an example of how this may happen. Some null detectors have very high leakage currents due to primary to secondary coupling in the power transformer used. These leakage currents can flow through the standard cell and the output resistance of the electronic standard. These problems can be reduced by:

- 1) Use of a null detector with low leakage currents, such as a Guildline 9460A/9461B galvanometer and nanovolt amplifier, or operating the null detector on batteries. Battery operation, while often provided on null detectors, should eliminate the problem, although it is often desirable to mount the null detector on a sheet of insulating material to overcome any leakage paths through its mounting feet. A moving coil galvanometer, such as the 9460A/9461B, used as a null detector can also provide good isolation.

- 2) Use of the electronic standard on the low side of the circuit (as shown in Fig. 6.) avoids leakage current problems. Operation on battery is another possibility. The 4410 has been designed with low leakage currents in mind and uses a specially made line transformer, specially made terminals, etc., to achieve very low leakage currents. If a problem does exist, it is a simple matter to change to battery operation.

An indication of leakage problems is often very apparent in the results of a series of measurements in which the bias and standard deviation are calculated. This is discussed in detail in section 8.00.00, "Statistical Use of the Outputs". For example, let us say in a comparison of four standard cells with the four 1.018V outputs of a 4410 by a half matrix method, the bias was found to be 3 μV and the standard deviation was found to be 1.5 μV , while the resolution of the LINDECK POTENTIOMETER was 0.1 μV . The figures for bias and standard deviation are much higher than would be expected, and suggest a leakage problem or possibly a shielding problem or an unstable thermal emf.

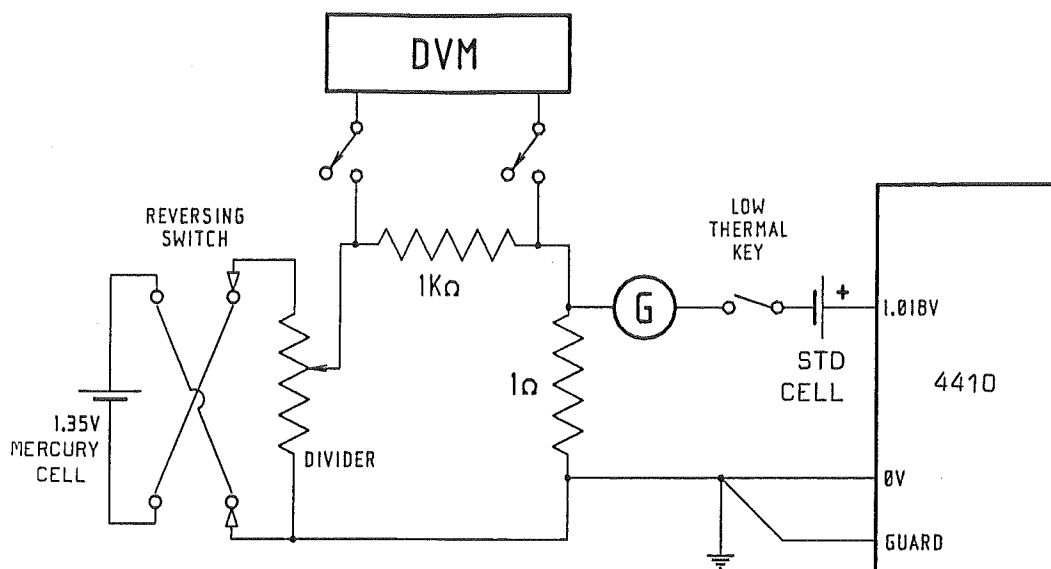

FIGURE 6

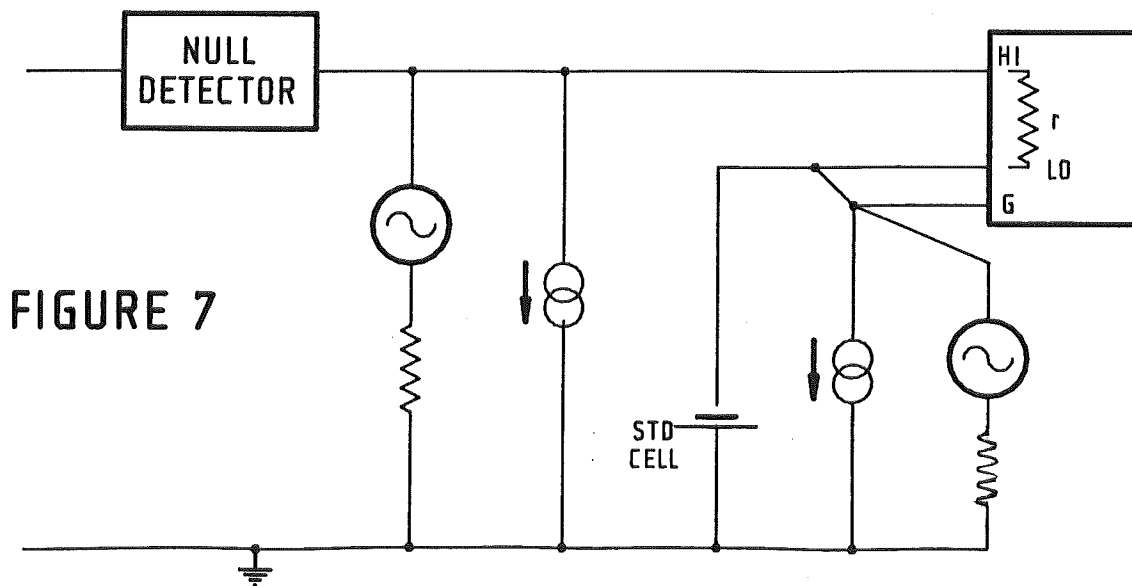

FIGURE 7

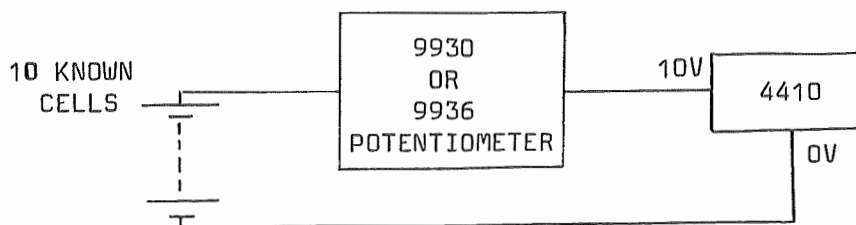

FIGURE 8

5.02.33 PREFERRED BACK TO BACK AGAINST STANDARD CELLS

Figure 8 shows a better way of calibrating the 4410 against standard cells at the 10V level. Connect ten known standard cells (9152's or 9154D's) in series, taking great care to avoid thermal emf's. The 9930 or 9936 Direct Current Comparator potentiometer is used to measure the difference. The leads to the potentiometer can be reversed to eliminate thermal emf's, and care should be taken to avoid possible leakage currents.

5.02.40 BACK TO BACK MEASUREMENTS OF 4410'S OWN OUTPUTS

This operation can be carried out using a reasonably good quality digital voltmeter, preferably with 100 nanovolt resolution on its most sensitive voltage range. An instrument with these characteristics will allow intercomparison of the 10V outputs and the 1.018V outputs to a few parts in 10^7 , indicating changes in any one of the 4410 outputs with respect to the others, thus providing a good confidence check.

The differences obtained can be compared with the most recent calibration certificate from the certifying laboratory to check that there has been no significant change in any one output which may indicate either a fault condition, or excessive drift. Where greater accuracy is required, the intercomparison can be carried out using a suitable potentiometer. Intercomparison and cross-comparison, and the statistical methods for data reduction are discussed in detail in section 8.00.00.

6.00.00 PERFORMANCE SPECIFICATIONS

OUTPUTS

Four at 10V
Four at 1.018V

LINE IMMUNITY

Battery Charging Section:

On 120V setting: 96V to 144V

On 240V setting: 192V to 288V

Output voltage of charger maintained within $\pm 2.5\%$ of recommended "float" voltage for typical sealed lead-acid batteries included. For line frequency 45Hz to 65Hz.

Output:

Influence of battery voltage within the limits of 11.6V and 14V (Low alarm point 11.7V) on the output: Limit: below noise.

NOISE

Less than:

0.1ppm RMS.

0.3 Hz to 10 Hz bandwidth.

ANNUAL DRIFT

Each of the 8 outputs (continuously energised)

First year, less than -3 ± 2 ppm.

Second year, less than -2 ± 2 ppm.

HYSTERESIS

After de-energisation for up to 2 days (battery totally discharged and not powered by line) and after 150 hours settling time. Total change: less than 0.5 ppm.

TEMPERATURE COEFFICIENT

Less than:

± 0.04 ppm/ $^{\circ}$ C.

Within oven control ambient range of 16 $^{\circ}$ C to 28 $^{\circ}$ C.

This temperature performance can be degraded by improper connection techniques, giving rise to thermal EMF's in the test lead connections, particularly for the 1.018V outputs. Refer to the operating instructions, section 5.00.00.

OVEN MONITOR

Oven operation may be checked by independent and isolated thermistor mounted in the oven mass and accessible at the rear panel. The thermistor resistance is tabulated on the calibration report.

ISOLATION, AC

Case to guard AC leakage current:

Less than 100 nA at 50Hz line frequency.

Less than 120 nA at 60Hz line frequency.

LEAKAGE RESISTANCE

Outputs to guard: greater than 10^{10} Ohms

Outputs to case: greater than 10^{11} Ohms

Case to guard: greater than 10^{11} Ohms

Measured at 50% relative humidity and 20-23°C after 24 hours operation on line power.

OPERATION ON BATTERY

Shipped fitted with two 12V, 7 A-H sealed lead-acid batteries, fully charged and operating in ambient not less than 20°C:
> 80 Hours.

In Transit Mode in Transit case after warm-up 20°C ambient:
> 130 Hours.

Battery operation time is a function of ambient temperature, and is longer at higher temperatures, shorter with lower.

ACCESSORIES

Reinforced Aluminum Foam-lined Transit case.
Technical manual.
Initial calibration records.
National Laboratory certificate (optional).
Batteries fitted.
Detachable line cord.

DIMENSIONS

Instrument: Width 365, Height 150, Depth 270 mm.
Instrument: Width 14.4, Height 5.9, Depth 10.6 inches.
Transit Case: Length 550, Height 500, Width 300 mm.
Transit Case: Length 21.7, Height 19.7, Width 11.8 inches.

WEIGHT Instrument: 27lb. 8oz (12.5Kg).
Transit Case: 20lb. 8oz (9.3Kg).

POWER REQUIREMENT

240V \pm 20%, OR 120V \pm 20%, 45-65Hz,
15 Watts maximum.

7.00.00 CERTIFICATION PROCEDURE

- 7.01.01 Initially establish a routine and time frame for certification - a certification timetable. This will depend upon the degree of certainty required. For example, for an industrial standards laboratory, calibration may be required annually. For a repair and calibration facility handling devices which require an accuracy of only 50ppm, calibration may be extended to 3 or 5 year intervals.

Before a 4410 is sent for calibration, it is good policy to intercompare the outputs and record the results. Comparison with any other standards is also desirable. This operation is repeated when the instrument is returned from the certifying laboratory to ensure that no changes have occurred due to transport and handling.

It is also prudent to intercompare the outputs regularly, say each month, and record these results together with cross comparisons made with other available standards, calibrators, or good quality digital voltmeters in use in the laboratory or service facility. By examination of the tabulated results, a drift, step change, or instability of any one output can be readily detected.

- 7.01.02 SECTION 5.00.00, OPERATION gives details on how the instrument should be operated, and precautions to be taken to avoid measurement errors. It is recommended that this technical manual, together with all accessories, be forwarded with the instrument whenever it is sent for certification. The manual should also of course accompany the instrument when sent to sub-branches or divisions of your organisation.
- 7.01.03 Should any questions arise as to the procedure for the certification of this instrument, performance parameters, etc., please do not hesitate to contact Guildline.

7.02.00 ADJUSTMENTS

7.02.01 GENERAL

All necessary adjustments are set at the factory and should not require any further attention, however since the adjustment potentiometers are accessible upon opening the instrument, the procedure for resetting is included in case they become disturbed through user intervention. There are NO adjustment potentiometers associated with the reference outputs.

7.02.02 BATTERY CHARGE VOLTAGE

The "float" voltage for the battery is set by RV1.1, on the "battery charge" module at the rear of the instrument. The adjustment potentiometer is accessible on removal of the top cover.

Connect the 4410 to the line and turn on power switch. Remove battery compartment cover and disconnect battery connectors. Connect a digital voltmeter to the battery connectors.

Switch power off for approximately one minute. On switch-on, the OVEN indicator will show LOW temperature. This simulates maximum oven power consumption. While this condition prevails, adjust the battery charge voltage with RV1.1 (Clockwise to increase) to the desired end-of-charge voltage. For the type fitted, 13.7 to 13.8 volts is recommended, at 20-25°C ambient.

7.02.03 LOW VOLTAGE TRIP POINT

Removal of the top cover only is required. With power turned ON, disconnect battery and connect a regulated laboratory power supply to the leads formerly connected to the battery, being careful to observe the correct polarity. Note that 13.8V, current limited to approx 400mA, will be connected to the laboratory power supply output terminals in the same polarity as its output. Ensure that the power supply is rated for this type of load.

The laboratory supply should be set at 11.7V. Check this setting by measurement at the connectors used for battery termination, in case of voltage drops through the leads. Turn OFF the power to the 4410. Power is now supplied by the external laboratory supply.

Adjust RV1.3 (Support Electronics Board - P18) very slowly anti-clockwise (lowering trip point threshold) until red MONITOR lamp begins to flash. The circuit has deliberate hysteresis, so it is necessary to turn RV1.3 clockwise by a considerable margin if the trip point is over-shot.

7.02.04 REGULATED OUTPUT

This adjustment is for the pre-regulator for the reference modules and should be made with great care using a Digital Voltmeter with a traceable uncertainty of better than 10mV on the range used for 11.6V.

With the instrument operating normally, connect the DVM above to the pins on J2.3 which are labelled "REF- and REF+" (Support Electronics Board, Page 18). Take great care not to touch adjacent pins on J2.3. Ensure that the outputs of the 4410 are still operating normally.

Adjust RV2.3 (Support Electronics Board, Page 18), for 11.60V +/- 20mV.

7.02.05 OTHER ADJUSTMENTS

No other adjustments are available to the user or service engineer, since these would only prejudice the performance of the instrument.

7.03.00 ESTIMATION OF OUTPUT RESISTANCE

The output resistance of the 10V outputs can be estimated using the following procedure.

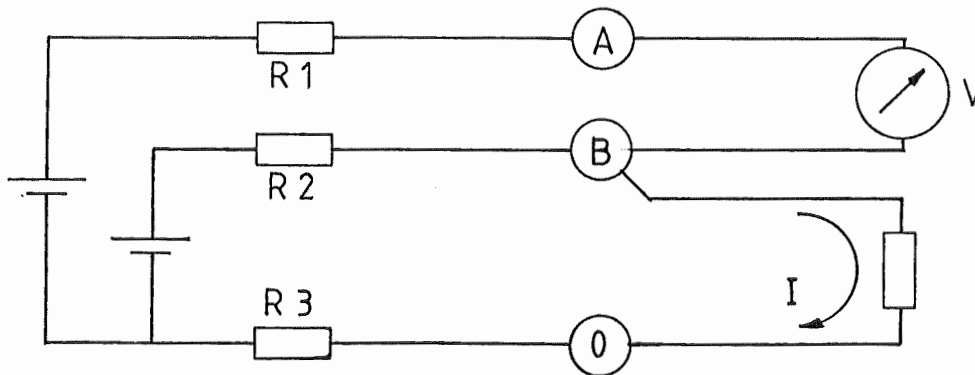

The output resistance is dominated by the lead resistance from the reference modules to the output terminals. The "R's" in the schematic can be considered equal. A null detector and low voltage source or very high input impedance digital voltmeter can be used to measure the difference voltage V. When a known current I of the order of 2 mA is drawn from one output, then V changes. $dV = IR_2 + IR_3 - IR_3$. A value for R2 is thus determined and multiplied by 2 to provide the estimate of output resistance.

8.00.00 STATISTICAL USE OF THE OUTPUTS

8.01.00 INTRODUCTION

8.01.01 The 4410 provides 4 independent output voltages at each of the two nominal voltages, 1.018V and 10V. The combination of several outputs at each nominal voltage makes a more stable reference than only one output. By taking the mean of four outputs, the effect of random variations of individual references is reduced. Moreover variations in output voltage are likely to be randomised simply by the passage of time, implying that even if in the short term each output may drift at its own constant rate, in the longer term this rate will itself vary at times and by amounts which differ for the four outputs. The mean voltage is therefore intrinsically more stable than any of its components.

8.01.02 Since, however, there is no physical "output terminal" for this mean voltage, it must be invoked by using each of the four outputs one at a time (at either of the two nominal levels) whenever a precise comparison with an external device is contemplated. The mean of the four voltages is then the reference voltage when the purpose of this comparison is the calibration of that device. When the device itself is a voltage source, of nominal value either 1.018V or 10V, it will naturally be compared with the group of four outputs of the 4410 at the same nominal voltage. As shown in Fig. 1 page 44, this comparison is made by connecting a null detector (ND) and a known variable low voltage source (LVS) (up to a few hundred microvolts) between each of the 4410 outputs in turn and the external device.

8.01.03 When, as frequently happens, the device itself contains several voltage sources, all of the same nominal value (1.018V or 10V), a systematised and efficient method of comparing the 4410 group with this device group is obviously desirable. In the following account the comparison between a 4410 group and the external group will be called a "cross-comparison". Sometimes, if the user has only a single 4410 standard as his source of precise voltages and would like to monitor their long-term variation, he will need to compare the four nominally equal 4410 outputs among themselves; this comparison will be called an "intercomparison".

8.01.04 To derive full benefit from either type of comparison its results must be analysed using statistical methods, and so we now digress briefly to make some preliminary very general remarks about statistical analysis as applied to comparisons between and within groups.

8.02.00 STATISTICAL BACKGROUND

8.02.01 Statistical analysis in the present context is largely devoted to the estimation of a few quantities from many measurements. This is why the analysis of experimental data is sometimes referred to as "data reduction". If there are P measurements and U unknown quantities to be estimated, then for the estimations to be reliable we require that P should be considerably greater than U . The measurements are then said to be "redundant". In statistics this term is not synonymous with "unnecessary" or "wasteful", but on the contrary has a desirable connotation akin to "generous".

8.02.02 Given the P redundant measurements, the U unknown quantities are commonly estimated using the method of least squares. Briefly described, this method starts with a "model" that we impose on the measurement process as a close description of it. This model is an equation or set of equations in which the measurements are the given quantities on the left-hand side, and the unknown quantities to be estimated and the random errors that unavoidably contaminate the measurements are on the right-hand side. Then to these unknown quantities values are assigned, called the "least squares estimates", which minimise the sum of squares of the errors.

8.02.03 There are three closely related reasons why redundancy is a welcome feature of measurements:

(a) Redundancy enables us to calculate the random errors of the measurement process. These random errors are generally referred to as "residuals", implying that they are unmodelled residue after the model has been imposed on the measurements.

(b) The residuals calculable from redundant measurements are sensitive to mistaken or highly erroneous readings, so that these can be detected and then either corrected or discarded. Otherwise expressed, the residuals indicate the degree of internal consistency of the original measurements.

(c) The greater the redundancy, the less sensitive the values of the estimated quantities will be to measurement error, and this is obviously a case where low sensitivity is an advantage.

- 8.02.04 The difference $F = P - U$ is called the number of "degrees of freedom" of the residuals, and should be as high as is permitted by the time and labour needed to do the measurements. After the U quantities have been estimated, the residuals are calculated. The sum of the residuals must be zero, and the sum of their squares, divided by F , is the square of a quantity known variously as the "observational precision" or "observational standard deviation", a convenient single-number indication of the precision of the original measurements. This observational precision next determines the random errors that attach to the U estimated quantities and that are often known as "standard errors", varying inversely roughly as the square root of P . The standard error of each of the U 's gives it a corresponding "confidence range", normally calculated assuming that the errors follow a probability distribution known as the "normal" or "Gaussian". This chain of calculations will be discussed and described below in detail.
- 8.02.05 As a simple particular example of the general statements above, suppose that only the mean is to be estimated of the eight measurements 6.1, 6.2, 6.1, 6.3, 5.9, 7.1, 6.0, 6.1. Here we have $P = 8$, $U = 1$ and $F = P - U = 7$. The mean is 6.225 and the respective residuals, obtained from subtracting the mean from each reading, are -0.125, -0.025, -0.125, 0.075, -0.325, 0.875, -0.225, -0.125. The only necessary linear relationship among the eight residuals is that their sum must be zero. This constraint on their variability is expressed by the fact that, although there are eight of them, they have only seven degrees of freedom: $F = 7$. The observational precision is 0.373. Among the residuals, 0.875 is prominent, and therefore its corresponding measurement, 7.1, is suspect. Although in this simple example the measurement 7.1 was obviously itself an "outlier" in the list of measurements, in the more complicated systems of measurements to be discussed below a suspect measurement would not necessarily be so easily discernible, and hence the sensitivity of the residuals referred to in (b) above would be valuable.
- 8.02.06 As examples of non-redundancy, suppose we attempted to estimate the mean using only one measurement ($U = P = 1$), or the slope and intercept of a line using only two measurements of coordinate pairs ($U = P = 2$). As common sense would indicate, none of these results would be reliable.

- 8.02.07 The cross-comparison of two groups and the intercomparison of one group both consist of a process of comparison of voltages in pairs. Thus if one group of n voltages is cross-compared with a group of m voltages, there is a maximum of $P = 2mn$ paired comparisons between groups. The factor 2 is included because each measurement must be made on forward and on reverse polarity in order to measure, then eliminate any measurement bias, most commonly the effect of a thermal emf. By "forward" and "reverse" polarity we mean the following: if Lead L1 is connected to one output and lead L2 to another output (which may belong either to an external device, as shown in Fig. 1, or to the same device as the first output), and if this configuration is called "forward polarity", then the configuration with L1 connected to the second output and L2 to the first output is "reverse polarity". However if m and n are each 4 or more (as a practical rather than a theoretical minimum) there exists an experimental procedure which, while still capable of measuring (and eliminating) the thermal emf, halves the number of measurements to mn and yet maintains reasonable redundancy.
- 8.02.08 The observational precision in this "half-design" will be naturally reduced compared to the full design, but only by a factor of the order of $\sqrt{2}$, and so the half design, taking only half as long, can on the whole be recommended in preference to a full design. Both designs will be discussed below.
- 8.02.09 In the following sections we define the terms "intercomparison" and "cross-comparison", and we give general formulae for the unknown voltages, particular formulae for the cases $n = 4$ or $m = 4$ since these are of special concern to the 4410 user, and worked examples of these formulae for the 1.018V outputs. In each case we also give the formulae for calculating the thermal emf, which is usually of the order of microvolts or less and is worth knowing, even though the taking of measurements on forward and on reverse polarity will eliminate its effect from the final results. The thermal emf is of course proportionally less important when the 10V outputs are compared. We next give formulae for the observational precision and the standard errors of the estimated voltages. The data reduction in all cases should be aided by calculator or computer, and to help with this final stage of the use of the 4410, we include listings of computer programmes in HP-85 BASIC, which is quite easily convertible to any preferred variant of BASIC.

8.03.00 DEFINITION OF INTERCOMPARISON AND CROSS-COMPARISON

8.03.01 Here and elsewhere, the term "group of voltages" or "group" will be understood to refer to a group of voltage outputs (or "outputs" for short), whether physically contained in the one unit, as for example the 4410, or physically separable but treated conceptually as a unit, as for example a group of electrochemical standard cells in an oil bath and having a common history.

8.03.02 "Intercomparison" is a procedure applied to only one group of n outputs. Their mean voltage M at a particular temperature must be known in advance (and we assume, here and elsewhere, that changes in voltage due to changes in temperature are either known to be negligible or have been allowed for). The n outputs are intercompared with one another in pairs, so that the data consist of $P = n(n-1)$ differences in voltage, obtained in a pattern to be described. Calculations on these $n(n-1)$ voltage differences yield: The n unknown voltages, of which $n - 1$ are independently variable since the sum of the n voltages must be nM , and an additional thermal emf.

Therefore $U = n - 1 + 1 = n$, and

$$F = P - U = n^2 - 2n.$$

8.03.03 "Cross-comparison" is a procedure applied to two groups of outputs, one group containing n outputs, the other m outputs. One group (for example, the group with n outputs) must have a higher status than the other, and is called the "reference" group (RG). The other group (with m outputs) is called the "test group" (TG). The n voltages in the RG must have a known mean emf M . Outputs in RG are compared with outputs in TG, but there is never any need to compare two outputs both belonging to the same group. The measurements consist of mn differences of voltage, obtained following a pattern to be described below, for the half-design, and $2mn$ differences for the full-design. Calculations on these mn or $2mn$ differences yield: the n voltages in RG (which are constrained to sum to nM), the m voltages in TG, and again a thermal emf. Evidently for the half-design

$$P = mn, U = m + n, F = P - U = mn - m - n,$$

whereas for the full design

$$P = 2mn, U = m + n \text{ and } F = 2mn - m - n.$$

8.03.04 Normally cross-comparisons are more efficient than intercomparisons, since the amount of observational work is about the same in both cases, yet gives information about two groups of voltages in the former case but only one group in the latter. The practical precision of the final results is about the same in the two cases. For these reasons, cross-comparisons are preferable to intercomparisons, and furthermore are suitable for laboratories where two groups of outputs are maintained, one of which, the TG, is used for tests by cross-comparison on groups sent by lower-echelon laboratories, while the other group, the RG, has a known mean voltage from higher-echelon measurements and is used in cross-comparisons with the TG for the regular monitoring of the voltages in both the RG and the TG.

8.04.00 SIGN CONVENTION

8.04.01 To avoid confusion, it is important to adhere to a sign convention when recording measurements of voltage difference. The following convention is suggested and followed here, both for intercomparisons and cross-comparisons. (See Fig. 1). Two leads from the comparison circuit, L1 and L2, are used to make contact with the respective positive terminals of the two voltages being compared. The leads should be distinctively marked, e.g. one of them, say L1, with a red band. The convention then is:

(i) When L1 is connected to voltage X, and L2 to voltage Y, and X has a higher voltage than Y, then the result of the comparison is given a positive sign.

(ii) When L1 is connected to voltage X, and L2 to voltage Y, and X has a lower voltage than Y, then the result of the comparison is given a negative sign.

(iii) Both (i) and (ii) are true whether the particular measurement is a "forward" measurement or a "reverse" measurement.

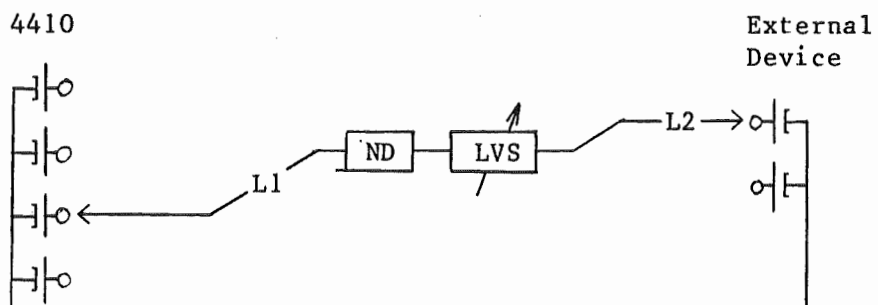

Fig. 1. Basic circuit for comparison of voltages of the same nominal value. ND: null detector. LVS: low voltage source. L1, L2, : Leads to voltage outputs.

8.05.00 INTERCOMPARISON of one group of n voltages which have a known mean M .

8.05.01 Fig. 2 shows a recommended pattern for the particular case of $n = 4$ voltages. The number of pairwise comparisons is $n(n-1) = 12$, and of these, 6 are the "forward" measurements and the other 6 the "reverse" measurements. Let E_i be the i th voltage and let y_{ij} be the measurement in microvolts of the voltage difference in the i th row and j th column of Fig. 2. The model is:

$$y_{ij} = E_j - E_i + B + e_{ij}$$

$$(i, j = 1, 2, \dots, n; i \neq j). \quad \dots(1)$$

B is the thermal emf and the e 's are the residuals.

The measurement data are the y_{ij} ; The E 's and B are quantities to be determined from the measurement data.

The technique of least-squares yields the following equations:

$$E_k = M + (1/2n) \sum_{i \neq k}^n (y_{ik} - y_{ki}) \quad (k = 1, 2, \dots, n) \quad \dots(2)$$

$$B = (1/n(n-1)) \sum_{i \neq j}^n y_{ij}. \quad \dots(3)$$

	1	2	3	4
1	---	F	F	F
2	R	---	F	F
3	R	R	---	F
4	R	R	R	---

Fig. 2.
Intercomparison of four voltages.
F = forward polarity,
R = reverse polarity.

After the E's and B have been calculated, the e_{ij} can be calculated using equation (1). A computational check is that the sum of these $n(n - 1)$ random "error" emf's must be zero.

The observational precision is given by:

$$s^2 = \sum_{i \neq j}^n e_{ij}^2 / (n^2 - 2n). \quad \dots(4)$$

The square of the standard error (s.e.) of the estimated E's and of the thermal B are given by:

$$\text{s.e.}^2(E) = (1/2n^2)(n-1)s^2 \quad \dots(5)$$

$$\text{s.e.}^2(B) = (1/n(n - 1))s^2. \quad \dots(6)$$

8.05.02 For the particular case $n = 4$, applying to the 4410 standard, there are $n^2 - 2n = 8$ degrees of freedom. Equations (2) and (3) become respectively:

$$\begin{aligned} E_1 &= M + (1/8)(y_{21} - y_{12} + y_{31} - y_{13} + y_{41} - y_{14}) \\ E_2 &= M + (1/8)(y_{12} - y_{21} + y_{32} - y_{23} + y_{42} - y_{24}) \\ E_3 &= M + (1/8)(y_{13} - y_{31} + y_{23} - y_{32} + y_{43} - y_{34}) \\ E_4 &= M + (1/8)(y_{14} - y_{41} + y_{24} - y_{42} + y_{34} - y_{43}) \end{aligned} \quad \dots(7)$$

$$\begin{aligned} B &= (1/12)(y_{12} + y_{13} + y_{14} + y_{21} + y_{23} + y_{24} + y_{31} \\ &+ y_{32} + y_{34} + y_{41} + y_{42} + y_{43}) \end{aligned} \quad \dots(8)$$

and equations (4), (5), (6) become respectively:

$$\begin{aligned} s^2 &= (1/8)(e_{12}^2 + e_{13}^2 + e_{14}^2 + e_{21}^2 + e_{23}^2 + e_{24}^2 + e_{31}^2 + \\ &e_{32}^2 + e_{34}^2 + e_{41}^2 + e_{42}^2 + e_{43}^2) \end{aligned} \quad \dots(9)$$

$$\text{s.e.}^2(E) = (3/32)s^2 \quad \dots(10)$$

$$\text{s.e.}^2(B) = (1/12)s^2. \quad \dots(11)$$

8.05.03 EXAMPLE:

A group of 4 voltage outputs has a known mean of 1.018 614 47 V, and an intercomparison of these outputs has provided the following 12 observations in microvolts:

	1	2	3	4
1	-----	-27.8	-31.5	-38.5
2	+27.9	-----	-3.8	-11.3
3	+31.6	+3.8	-----	-7.4
4	+38.9	+11.2	+7.5	-----

Applying equations (2) and (3) gives the following results:

$$E_1 = 1.018\ 639\ 00\ \text{V}$$

$$E_2 = 1.018\ 611\ 27\ \text{V}$$

$$E_3 = 1.018\ 607\ 50\ \text{V}$$

$$E_4 = 1.018\ 600\ 12\ \text{V}$$

$$\text{and } B = +0.050\ \mu\text{V.}$$

The residual emf's are as follows in microvolts, obtained on 8 degrees of freedom:

	1	2	3	4
1	-----	-0.125	-0.050	+0.325
2	+0.125	-----	-0.075	-0.200
3	+0.050	-0.025	-----	-0.075
4	+0.025	+0.000	+0.075	-----

and the observational precision s is:

$$s = 0.158\ \mu\text{V.}$$

The standard errors are given by:

$$\text{s.e. } (E) = 0.048\ \mu\text{V for each of the } E\text{'s}$$

and

$$\text{s.e. } (B) = 0.046\ \mu\text{V.}$$

- 8.05.04 The interpretation of the standard errors will be discussed later. As in the cases of cross-comparison to follow, the array of residuals can reveal a bad measurement or erroneous reading of a measurement (for example, an omitted minus sign) in the original array of voltage differences. That residual in the array corresponding to the mistake will be much larger than the other residuals. This sensitivity to mistaken readings is a good reason for calculating the residuals and setting them out in array form.
- 8.06.00 FULL-DESIGN CROSS-COMPARISON of one group (RG) of n voltages with another group (TG) of m voltages.
- 8.06.01 For both the full and half-designs, the following circuit convention will be useful:
- (i) When L1 is connected to one of the voltages in RG and L2 to one of the voltages in TG, the measurement is one of the "forward" series.
- (ii) When L1 is connected to one of the voltages in TG and L2 to one of the voltages in RG, the measurement is one of the "reverse" series.

Fig. 3.
Full-design cross-comparison
of RG with 4 outputs, and TG
with two outputs.

		RG			
		1	2	3	4
TG	1	F	F	F	F
	2	R	R	R	R

Fig 3. shows the suggested tabulation of measurements for the case $n = 4$ and $m = 2$. All the forward measurements are taken first, going left to right, top to bottom (in "reading" sequence). The RG outputs are assigned to the columns and the TG outputs to the rows. In the measurement sequence, the electrical connections may be described as: L1 moving from RG output 1, to RG output 2, ...to RG output n , while L2 is all the while kept fixed on TG output 1. All this is now repeated for TG output 2, ...TG output m . Then the reverse measurements are taken: L2 moving from RG output 1, to RG output 2, ...to RG output n , while L1 is kept fixed on TG output 1. All this is now repeated for TG output 2, ...TG output m .

Let D_r be the voltage of the r th output in TG ($r = 1, 2, \dots, m$), let E_k be the voltage of the k th output in RG ($k = 1, 2, \dots, n$), and let B be the thermal emf. The mean of the n voltages in RG is known in advance.

Let y_{ij} be the forward measurement of voltage difference between output i in TG and output j in RG. Thus y_{23} is the measurement when L1 is connected to output 3 in RG and L2 is connected to output 2 in TG.

Let z_{ij} be the reverse measurement of voltage difference between output i in TG and output j in RG. Thus z_{23} is the measurement when L2 is connected to output 3 in RG and L1 is connected to output 2 in TG.

The subscript i counts the rows ($i = 1, 2, \dots, m$), and the subscript j counts the columns ($j = 1, 2, \dots, n$) in the tabulation of Fig. 3.

The model is then:

$$\begin{aligned} y_{ij} &= E_j - D_i + B + e_{ij} \\ z_{ij} &= D_i - E_j + B + e_{ij}' \end{aligned} \quad \dots(12)$$

The following equations determine the E 's, the D 's and the B :

$$D_r = M - (1/2n) \sum_{j=1}^n (y_{rj} - z_{rj}) \quad \text{for } r = 1, 2, \dots, m \quad \dots(13)$$

$$E_k = M' + (1/2m) \sum_{i=1}^m (y_{ik} - z_{ik}) \quad \text{for } k = 1, 2, \dots, n \quad \dots(14)$$

$$B = (1/2mn) \sum_{i,j}^{m,n} (y_{ij} + z_{ij}) \quad \dots(15)$$

where M' is the mean of all the m TG voltages (the D 's) calculated using equation (13).

The $2mn$ residuals can now be calculated. As a computational check, the sum of the mn forward residuals must be zero, and likewise the sum of the mn reverse residuals.

The observational precision is given by:

$$s^2 = \frac{\sum_{i,j}^{m,n} e_{ij}^2}{(2mn - n - m)} \quad \dots(16)$$

and the standard errors of the E's, the D's and the B are given by:

$$s.e.^2(E) = s^2(n-1)/2mn \quad \dots(17)$$

$$s.e.^2(D) = s^2/2n \quad \dots(18)$$

$$s.e.^2(B) = s^2/2mn. \quad \dots(19)$$

8.06.02 If we take the particular case $n = 4$ outputs in the RG and $m = 2$ outputs in the TG, the equations above become:

$$\begin{aligned} D_1 &= M - (1/8)[(y_{11} - z_{11}) + (y_{12} - z_{12}) + (y_{13} - z_{13}) + (y_{14} - z_{14})] \\ D_2 &= M - (1/8)[(y_{21} - z_{21}) + (y_{22} - z_{22}) + (y_{23} - z_{23}) + (y_{24} - z_{24})] \end{aligned} \quad \dots(20)$$

and letting $M' = (D_1 + D_2)/2$,

$$\begin{aligned} E_1 &= M' + (1/4)[(y_{11} - z_{11}) + (y_{21} - z_{21})] \\ E_2 &= M' + (1/4)[(y_{12} - z_{12}) + (y_{22} - z_{22})] \\ E_3 &= M' + (1/4)[(y_{13} - z_{13}) + (y_{23} - z_{23})] \\ E_4 &= M' + (1/4)[(y_{14} - z_{14}) + (y_{24} - z_{24})] \end{aligned} \quad \dots(21)$$

$$B = (1/16)(y_{11} + y_{12} + y_{13} + y_{14} + y_{21} + y_{22} + y_{23} + y_{24} + z_{11} + z_{12} + z_{13} + z_{14} + z_{21} + z_{22} + z_{23} + z_{24}) \quad \dots(22)$$

The 16 residuals can now be calculated and then:

$$s^2 = (1/10)(\text{sum of squares of residuals}), \text{ there being } 2mn - n - m = 10 \text{ degrees of freedom, so that:} \quad \dots(23)$$

$$s.e.^2(E) = (3/16)s^2 \quad \dots(24)$$

$$s.e.^2(D) = (1/8)s^2 \quad \dots(29)$$

$$s.e.^2(B) = (1/16)s^2. \quad \dots(26)$$

8.06.03

EXAMPLE:

A full cross-comparison between a RG of 4 outputs, with a mean of 1.018 615 80, and a TG with 2 outputs has given the following differences in microvolts:

		RG			
		1	2	3	4
TG	1F	-40.6	-40.9	-57.4	-53.6
	1R	+40.4	+40.7	+57.2	+53.7
	2F	-23.1	-23.1	-40.1	-36.3
	2R	+22.6	+23.0	+39.6	+36.0

Applying equations (20), (21), (22), gives:

$$E_1 = 1.018\ 623\ 39\ \text{V}$$

$$E_2 = 1.018\ 623\ 14\ \text{V}$$

$$E_3 = 1.018\ 606\ 49\ \text{V}$$

$$E_4 = 1.018\ 610\ 17\ \text{V}$$

$$D_1 = 1.018\ 663\ 86\ \text{V}$$

$$D_2 = 1.018\ 646\ 28\ \text{V}$$

$$B = -0.119\ \mu\text{V}.$$

The array of residuals is:

		RG			
		1	2	3	4
TG	1F	-0.013	-0.063	+0.088	+0.213
	1R	+0.050	+0.100	-0.050	+0.125
	2F	-0.100	+0.150	-0.200	-0.075
	2R	-0.163	-0.013	-0.063	+0.013

This array gives:

$$s = 0.140\ \mu\text{V}$$

$$s.e.(E) = 0.061\ \mu\text{V}$$

$$s.e.(D) = 0.049\ \mu\text{V}$$

$$s.e.(B) = 0.035\ \mu\text{V}.$$

8.07.00 HALF-DESIGN CROSS-COMPARISON of one group (RG) of n outputs with another group (TG) of m outputs.

8.07.01 Fig 4. shows a recommended pattern for the particular case $n = 4, m = 6$. The number of pairwise comparisons is $mn = 24$. Let E_i ($i = 1, 2, \dots, n$) be the i th voltage in RG, and let D_i ($i = 1, 2, \dots, m$) be the i th voltage in TG. Let y_{ij} be the measurement in microvolts of the voltage difference in the i th row and j th column of Fig 4. The model is:

$$y_{ij} = (-1)^{i+j} (E_j - D_i) + B + e_{ij} \quad \dots(27)$$

where the B's and the e's have the same meanings as in equations (12).

Fig. 4.
Half design cross-comparison of RG with 4 outputs, and TG with 6 outputs

		RG			
		1	2	3	4
TG	1	F	R	F	R
	2	R	F	R	F
	3	F	R	F	R
	4	R	F	R	F
	5	F	R	F	R
	6	R	F	R	F

Referring to Fig 4, it is convenient to take all the forward measurements first, working from left to right in row 1, then in row 2 and so on up to row m , then similarly taking all the reverse measurements. The equations giving the E's, D's and the B in terms of the observed y's are as follows. We have to distinguish four cases: m, n both even as in Fig 4, m odd and n even, m even and n odd, and both m and n odd. It is useful first to define quantities as follows, where the index i is taken from 1 to m and the index j from 1 to n :

$$S = \sum_{i,j} y_{ij} \quad \dots(28)$$

$$T = \sum_{i,j} y_{ij} (-1)^{i+j} \quad \dots(29)$$

$$U = \sum_j (-1)^j \sum_i y_{ij} \quad \dots(30)$$

$$V = \sum_i (-1)^i \sum_j y_{ij} \quad \dots(31)$$

and

$$g_k = \sum_i y_{ik} (-1)^i \quad \dots(32)$$

$$G_k = (-1)^k g_k \quad \dots(33)$$

$$h_r = \sum_j y_{rj} (-1)^j \quad \dots(34)$$

$$H_r = (-1)^r h_r \quad \dots(35)$$

In the equations below for E_k and D_r , the index k extends from 1 to n and the index r from 1 to m .

(i) m, n both even. This is the simplest and also most common case, as the 4410 and most of the commercially available thermocontrolled enclosures for standard cells contain an even number of outputs.

$$E_k = M - (T/mn) + G_k/m \quad \dots(36)$$

$$D_r = M - (H_r/n) \quad \dots(37)$$

$$B = S/mn. \quad \dots(38)$$

For the other three cases, define the quantities:

$$L = 1/(n^2 - 1) \quad \dots(39)$$

$$L' = 1/(m^2 - 1). \quad \dots(40)$$

(ii) n even, m odd.

$$E_k = M - (T/mn) + (-1)^k [(g_k/m) + (L'/n)(S + (V/m))] \quad \dots(41)$$

$$D_r = M - H_r/n \quad \dots(42)$$

$$B = (mL'/n)(S + (V/m)). \quad \dots(43)$$

(iii) n odd, m even.

$$E_k = M - (T/mn) + (G_k/m) \quad \dots(44)$$

$$D_r = M - (-1)^r [(h_r/n) + (L/m)(S + (U/n))] \quad \dots(45)$$

$$B = (nL/m)(S + (U/n)). \quad \dots(46)$$

(iv) m, n both odd.

We define first the quantity:

$$W = nmS + nV + mU + T \quad \dots(47)$$

$$E_k = M - (T/mn) + (G_k/m) + LL'(1 + (-1)^k n)(W/mn) \quad \dots(48)$$

$$D_r = M - (H_r/n) - (-1)^r LL'W/n \quad \dots(49)$$

$$B = WLL'. \quad \dots(50)$$

The residuals (e's) can now be calculated, and the observational precision for any of the four cases above is given by:

$$s^2 = \sum_{i,j} e_{ij}^2 / (nm - n - m). \quad \dots(51)$$

The standard errors are now calculated as follows:

(i) m, n both even.

$$s.e.^2(E) = s^2(n - 1)/mn \quad \dots(52)$$

$$s.e.^2(D) = s^2/n \quad \dots(53)$$

$$s.e.^2(B) = s^2/mn. \quad \dots(54)$$

(ii) n even, m odd

$$s.e.^2(E) = s^2(1/m)(1 - (2/n) + mL'/n) \quad \dots(55)$$

$$s.e.^2(D) = s^2/n \quad \dots(56)$$

$$s.e.^2(B) = s^2(mL'/n). \quad \dots(57)$$

(iii) n odd, m even.

$$s.e.^2(E) = s^2(n - 1)/mn \quad \dots(58)$$

$$s.e.^2(D) = (s^2/n)(1 + L/m) \quad \dots(59)$$

$$s.e.^2(B) = s^2(nL/m). \quad \dots(60)$$

(iv) m, n both odd.

$$s.e.^2(E_k) = s^2(1/m)(1 - (1/n) + LL'(n^2 + 1 + 2n(-1)^k/n) \quad \dots(61)$$

$$s.e.^2(D) = (s^2/n)(1 + mL'L) \quad \dots(62)$$

$$s.e.^2(B) = s^2_{mn}LL'. \quad \dots(63)$$

8.07.02 For the particular case n = 4 and m = 6 we have:

$$S = (y_{11} + y_{12} + y_{13} + y_{14} + y_{21} + y_{22} + y_{23} + y_{24} + y_{31} + y_{32} + y_{33} + y_{34} + y_{41} + y_{42} + y_{43} + y_{44} + y_{51} + y_{52} + y_{53} + y_{54} + y_{61} + y_{62} + y_{63} + y_{64}) \quad \dots(64)$$

$$T = (y_{11} - y_{12} + y_{13} - y_{14} - y_{21} + y_{22} - y_{23} + y_{24} + y_{31} - y_{32} + y_{33} - y_{34} - y_{41} + y_{42} - y_{43} + y_{44} + y_{51} - y_{52} + y_{53} - y_{54} - y_{61} + y_{62} - y_{63} + y_{64}) \quad \dots (65)$$

$$G_1 = -(-y_{11} + y_{21} - y_{31} + y_{41} - y_{51} + y_{61}) \quad \dots (66)$$

$$G_2 = (-y_{12} + y_{22} - y_{32} + y_{42} - y_{52} + y_{62}) \quad \dots (67)$$

$$G_3 = -(-y_{13} + y_{23} - y_{33} + y_{43} - y_{53} + y_{63}) \quad \dots (68)$$

$$G_4 = (-y_{14} + y_{24} - y_{34} + y_{44} - y_{54} + y_{64}) \quad \dots (69)$$

$$H_1 = -(-y_{11} + y_{12} - y_{13} + y_{14}) \quad \dots (70)$$

$$H_2 = (-y_{21} + y_{22} - y_{23} + y_{24}) \quad \dots (71)$$

$$H_3 = -(-y_{31} + y_{32} - y_{33} + y_{34}) \quad \dots (72)$$

$$H_4 = (-y_{41} + y_{42} - y_{43} + y_{44}) \quad \dots (73)$$

$$H_5 = -(-y_{51} + y_{52} - y_{53} + y_{54}) \quad \dots (74)$$

$$H_6 = (-y_{61} + y_{62} - y_{63} + y_{64}) \quad \dots (75)$$

Then the estimated voltages are as follows:

$$\begin{aligned} E_1 &= M - (T/24) + G_1/6 \\ E_2 &= M - (T/24) + G_2/6 \\ E_3 &= M - (T/24) + G_3/6 \\ E_4 &= M - (T/24) + G_4/6 \end{aligned} \quad \dots (76)$$

$$\begin{aligned} D_1 &= M - (H_1/4) \\ D_2 &= M - (H_2/4) \\ D_3 &= M - (H_3/4) \\ D_4 &= M - (H_4/4) \\ D_5 &= M - (H_5/4) \\ D_6 &= M - (H_6/4) \end{aligned} \quad \dots (77)$$

$$\text{and } B = S/24. \quad \dots (78)$$

$$s^2 = (1/14)(\text{sum of squares of residuals}), \text{ there being } mn - n - m = 14 \text{ degrees of freedom;} \quad \dots (79)$$

$$\text{s.e.}^2(E) = (1/8)s^2 \quad \dots (80)$$

$$\text{s.e.}^2(D) = (1/4)s^2 \quad \dots (81)$$

$$\text{s.e.}^2(B) = (1/24)s^2. \quad \dots (82)$$

8.07.03

EXAMPLE:

An RG of 4 outputs is cross-compared with a TG of 6 outputs using a half-design. The RG mean M is 1.018 612 96 V. The 24 observations, made following the pattern of Fig. 4, are as follows in microvolts:

	1	2	3	4
TG1	-8.4	+8.1	-7.5	+8.1
TG2	+8.4	-7.6	+7.7	-7.4
TG3	-8.1	+8.1	-7.4	+8.0
TG4	+8.8	-7.9	+7.9	-7.8
TG5	-7.6	+7.7	-7.2	+7.9
TG6	+8.6	-7.9	+7.9	-7.8

Applying equations (64) to (78) gives:

$$E_1 = 1.018\ 612\ 55\ \text{V}$$

$$E_2 = 1.018\ 612\ 98\ \text{V}$$

$$E_3 = 1.018\ 613\ 27\ \text{V}$$

$$E_4 = 1.018\ 613\ 04\ \text{V}$$

and

$$D_1 = 1.018\ 620\ 99\ \text{V}$$

$$D_2 = 1.018\ 620\ 74\ \text{V}$$

$$D_3 = 1.018\ 620\ 86\ \text{V}$$

$$D_4 = 1.018\ 621\ 06\ \text{V}$$

$$D_5 = 1.018\ 620\ 56\ \text{V}$$

$$D_6 = 1.018\ 621\ 01\ \text{V}$$

$$B = 0.192\ \mu\text{V}.$$

The residuals are (in microvolts):

	1	2	3	4
TG1	-0.158	-0.092	0.025	-0.042
TG2	0.025	-0.042	0.042	0.108
TG3	0.017	0.033	0.000	-0.017
TG4	0.100	-0.017	-0.083	0.033
TG5	0.217	-0.067	-0.100	0.183
TG6	-0.050	-0.067	-0.033	-0.017

and the observational precision is:

$$s = 0.112\ \mu\text{V}$$

The standard errors are given by:

$$\text{s.e.}(E) = 0.040\ \mu\text{V}$$

$$\text{s.e.}(D) = 0.056\ \mu\text{V}$$

$$\text{s.e.}(B) = 0.023\ \mu\text{V}.$$

8.08.00 CONFIDENCE RANGES

A quantity which has been estimated from several measurements has an estimated value, but since the measurements are very unlikely to be mutually perfectly consistent the estimated value will not necessarily be equal to the true value of the quantity. Even if the measurements were perfectly consistent, a systematic error might still exist which, uniformly affecting all the measurements, did not spoil their mutual consistency but affected the estimated value calculated using them. An example of such a systematic error might be an incorrect value for the mean M of a group of voltages.

8.08.01 In general the only way to detect and eliminate a systematic error is to make a deliberate and sometimes quite drastic change in the experimental hardware or technique; one example is lead reversal to detect and eliminate a thermal emf. However, the mutual consistency of the measurements, also known as the "observational precision", still provides a useful kind of figure of merit for the measurement process, and the derived concept of a quantity's "standard error", a linear function of the observational precision, provides a quantitative answer to the unavoidable question: "How precisely did you measure it?" (The question: "How accurately did you measure it?" is harder to answer, since, according to the now accepted terminology, an "accurate" result is one which is believed to be free of all systematic errors).

8.08.02 The concept of a "confidence range" follows very naturally from the standard error. A confidence range is always associated with a probability not much less than 100% and most commonly 95% or 99%. A 99% confidence range centred on the estimated value of a quantity is that range in which its true value exists with 99% confidence. Naturally a 95% confidence range is shorter than a 99% confidence range. Standard errors may be converted to confidence ranges by multiplication by a factor which depends on the number of degrees of freedom.

Degrees of freedom	Factor for 95% confidence	Factor for 99% confidence
6	2.4	3.7
7	2.4	3.5
8	2.3	3.4
9	2.3	3.2
10	2.2	3.2
12	2.2	3.0
15	2.1	3.0
20	2.1	2.8
30	2.0	2.8
very many	2.0	2.6

The factor is understood to have a plus-or-minus sign.

8.08.03

For example, in the case of the worked example of the intercomparison above there were 8 degrees of freedom, and the standard error of the estimated voltages of the four outputs was 0.048 μ V. The precision with which each of them was measured may be stated as a 99% confidence range: for example, the third output voltage was

$$1.018\ 607\ 50\ \text{V} \pm (3.4 \times 0.048\ \mu\text{V})$$

$$= 1.018\ 607\ 50\ \text{V} \pm 0.16\ \mu\text{V}$$

so that we are 99% confident that the true value of the third output lay in the range

$$1.018\ 607\ 34\ \text{V} \text{ to } 1.018\ 607\ 66\ \text{V}.$$

A confidence range may also indicate whether a small quantity is significant or negligible. In the same example, the thermal emf was + 0.050 μ V with a standard error 0.046 μ V. The 99% confidence range for the thermal emf was therefore + 0.050 μ V \pm (3.4 X 0.046 μ V). Thus the 99% confidence range for the thermal emf extends from - 0.11 μ V to + 0.21 μ V. Since this range comfortably encloses zero microvolts, the thermal emf may be regarded as not significant, or, stating the matter more carefully, the observational precision was not high enough to detect a significant thermal emf with 99% confidence.

8.09.00 PROGRAMS FOR STATISTICAL ANALYSIS IN HP-85 BASIC.

8.09.10 INTERCOMPARISON PROGRAM.

```

10 REM VOLT-OUTPUT INTERCOMPARIS
ON
20 DISP "NO. OUTPUTS?"
30 INPUT N
40 DISP "NAME OF GROUP?"
50 INPUT A$
60 DISP "GROUP MEAN (V)?"
70 INPUT M
80 DISP "DATE OF MEASUREMENT?"
90 INPUT C$
100 FOR I=1 TO N
110 FOR J=1 TO N
120 IF J=I THEN 150
130 DISP "ROW ";I;" COLUMN ";J
140 INPUT Y(I,J)
150 NEXT J
160 NEXT I
170 FOR I=1 TO N
180 Y(I,I)=0
190 NEXT I
200 REM LEAST-SQUARES CALCULATIO
N BEGINS
210 F=N^2-2*N
220 S=0
230 FOR J=1 TO N
240 S1(J)=0
250 FOR I=1 TO N
260 S1(J)=S1(J)+Y(I,J)-Y(J,I)
270 S=S+Y(I,J)
280 NEXT I
290 E(J)=M+1/(2*N)*S1(J)/1000000

300 NEXT J
310 B=1/(N*(N-1))*S
320 S=0
330 Q=0
340 FOR J=1 TO N
350 FOR I=1 TO N
360 IF I=J THEN 400
370 R(I,J)=Y(I,J)-(E(J)-E(I))*10
00000-B
380 S=S+R(I,J)
390 Q=Q+R(I,J)^2
400 NEXT I
410 NEXT J
420 W=SQR(Q/F)
430 W1=W*SQR((N-1)/(2*N*N))
440 W3=W*SQR(1/(N*(N-1)))
450 IMAGE "VOLT OUTPUT INTERCOMP
ARISON"
460 PRINT USING 450
470 IMAGE "DATE ",18A
480 PRINT USING 470 ; C$
490 IMAGE "GROUP ",8A
500 PRINT USING 490 ; A$
510 IMAGE "GIVEN GROUP MEAN ",DD
D.8D," V"
520 PRINT USING 510 ; M
530 PRINT "OBSERVED DIFFERENCES
AND RESIDUALS (uV)"
540 IMAGE 14X,"OBS",5X,"RES"
550 PRINT USING 540
560 IMAGE "OUTPUT ",DD
570 IMAGE "OUTPUT ",DD,6D.D,4D.D
DD
580 FOR I=1 TO N
590 PRINT USING 560 ; I
600 FOR J=1 TO N
610 IF J=I THEN 630
620 PRINT USING 570 ; J,Y(I,J),R
(I,J)
630 NEXT J
640 IMAGE /
650 PRINT USING 640
660 NEXT I
670 PRINT USING 640
680 IMAGE "SUM OF RESIDUALS ",DD
.DDD," uV"
690 PRINT USING 680 ; S
700 IMAGE "OBS ST DEV IS ",DD.DD
D," uV BASED ON ",DD," DEGREES O
F FREEDOM"
710 PRINT USING 700 ; W,F
720 IMAGE "BIAS ",16X,DD.DDD," u
V"
730 PRINT USING 720 ; B
740 IMAGE "OUTPUT ST ERR ",7X,DD
.DDD," uV"
750 PRINT USING 740 ; W1
760 IMAGE "BIAS ST ERR ",9X,DD.D
DD," uV"
770 PRINT USING 760 ; W3
780 PRINT USING 640
790 IMAGE DD,3X,3D.8D," V"
800 FOR I=1 TO N
810 PRINT USING 790 ; I,E(I)
820 NEXT I
830 END

```

8.09.11 INTERCOMPARISON PROGRAM.
TYPICAL PRINTOUT EXAMPLE

VOLT OUTPUT INTERCOMPARISON

DATE 10 JULY 1985

GROUP RG-C

GIVEN GROUP MEAN 1.01861447 V

OBSERVED DIFFERENCES AND RESIDUALS (uV)

	OBS	RES
OUTPUT 1		
OUTPUT 2	-27.8	-.125
OUTPUT 3	-31.5	-.050
OUTPUT 4	-38.5	.325

OUTPUT 2		
OUTPUT 1	27.9	.125
OUTPUT 3	-3.8	-.075
OUTPUT 4	-11.3	-.200

OUTPUT 3		
OUTPUT 1	31.6	.050
OUTPUT 2	3.8	-.025
OUTPUT 4	-7.4	-.075

OUTPUT 4		
OUTPUT 1	38.9	-.025
OUTPUT 2	11.2	0.000
OUTPUT 3	7.5	.075

SUM OF RESIDUALS 0.000 uV

OBS ST DEV IS .158 uV BASED ON 8 DEGREES OF FREEDOM

BIAS .050 uV

OUTPUT ST ERR .048 uV

BIAS ST ERR .046 uV

1	1.01863900 V
2	1.01861127 V
3	1.01860750 V
4	1.01860012 V

8.09.20 FULL-DESIGN CROSS-COMPARISON PROGRAM.

```

10 REM VOLT OUTPUT CROSS-COMPARI
SON - FULL DESIGN
20 DISP "NO. REF OUTPUTS?"
30 INPUT N1
40 DISP "NO. TEST OUTPUTS?"
50 INPUT N2
60 DISP "NAME OF REF. GROUP?"
70 INPUT A$
80 DISP "NAME OF TEST GROUP?"
90 INPUT B$
100 DISP "REF GROUP MEAN (V)?"
110 INPUT M
120 DISP "DATE OF MEASUREMENT?"
130 INPUT C$
140 DISP "FORWARD MEASUREMENTS (
uV)"
150 FOR I=1 TO N2
160 FOR J=1 TO N1
170 DISP "ROW ";I;" COLUMN ";J
180 INPUT Y(I,J)
190 NEXT J
200 NEXT I
210 DISP "REVERSE MEASUREMENTS (
uV)"
220 FOR I=1 TO N2
230 FOR J=1 TO N1
240 DISP "ROW ";I;" COLUMN ";J
250 INPUT Z(I,J)
260 NEXT J
270 NEXT I
280 REM E FOR RG, D FOR TG CELLS

290 REM B1 BIAS, R RESIDUALS
300 S2=0
310 FOR I=1 TO N2
320 S2(I)=0
330 FOR J=1 TO N1
340 S2(I)=S2(I)+(Y(I,J)-Z(I,J))
350 NEXT J
360 D(I)=M-S2(I)/(2*N1*1000000)
370 S2=S2+D(I)
380 NEXT I
390 M2=S2/N2
400 B=0
410 FOR J=1 TO N1
420 S1(J)=0
430 FOR I=1 TO N2
440 S1(J)=S1(J)+(Y(I,J)-Z(I,J))
450 B=B+Y(I,J)+Z(I,J)
460 NEXT I
470 E(J)=M2+S1(J)/(2*N2*1000000)
480 NEXT J
490 B1=B/(2*N1*N2)
500 R1=0
510 R2=0
520 Q=0
530 FOR I=1 TO N2
540 FOR J=1 TO N1
550 R1(I,J)=Y(I,J)-(E(J)-D(I))*1
000000-B1
560 R2(I,J)=Z(I,J)-(D(I)-E(J))*1
000000-B1
570 R1=R1+R1(I,J)
580 R2=R2+R2(I,J)
590 Q=Q+R1(I,J)^2+R2(I,J)^2
600 NEXT J
610 NEXT I
620 F=2*N1*N2-N1-N2
630 W=SQR(Q/F)
640 IMAGE "VOLT OUTPUT CROSS-COM
PARISON"
650 IMAGE "FULL DESIGN"
660 PRINT USING 640
670 PRINT USING 650
680 IMAGE "DATE ",18A
690 PRINT USING 680 ; C$
700 IMAGE "REFERENCE GROUP RG IS
",8A

```

8.09.20 FULL-DESIGN CROSS-COMPARISON PROGRAM (CONTINUED).

```

710 PRINT USING 700 ; A$
720 IMAGE "TEST GROUP TG IS ",5X
,8A
730 PRINT USING 720 ; B$
740 PRINT USING 880
750 IMAGE "GIVEN RG MEAN ",DDD.8
D," V"
760 PRINT USING 750 ; M
770 PRINT "OBSERVED DIFFERENCES
& RESIDUALS (uV)"
780 PRINT "FORWARD MEASUREMENTS
(uV)"
790 IMAGE 16X,"OBS",5X,"RES"
800 PRINT USING 790
810 IMAGE "RG OUTPUT ",DD
820 IMAGE "TG OUTPUT ", DD,5D
.D,4D.DDD
830 FOR J=1 TO N1
840 PRINT USING 810 ; J
850 FOR I=1 TO N2
860 PRINT USING 820 ; I,Y(I,J),R
1(I,J)
870 NEXT I
880 IMAGE /
890 PRINT USING 880
900 NEXT J
910 PRINT USING 880
920 PRINT "REVERSE MEASUREMENTS
(uV)"
930 PRINT USING 790
940 FOR J=1 TO N1
950 PRINT USING 810 ; J
960 FOR I=1 TO N2
970 PRINT USING 820 ; I,Z(I,J),R
2(I,J)
980 NEXT I
990 PRINT USING 880
1000 NEXT J
1010 PRINT USING 880
1020 IMAGE "SUM OF FORW RESIDUAL
S ",DD.DDD," uV"
1030 PRINT USING 1020 ; R1
1040 IMAGE "SUM OF REV RESIDUAL
S ",DD.DDD," uV"
1050 PRINT USING 1040 ; R2
1060 IMAGE "OBS ST DEV IS",2D.DD
D," uV BASED ON "2D," DEGREES O
F FREEDOM"
1070 PRINT USING 1060 ; W,F
1080 W1=W*SQR((N1-1)/(2*N1*N2))
1090 W2=W/SQR(2*N1)
1100 W3=W/SQR(2*N1*N2)
1110 IMAGE "TG OUTPUT ST ERR ",3
X,DD.DDD," uV"
1120 PRINT USING 1110 ; W2
1130 IMAGE "RG OUTPUT ST ERR ",3
X,DD.DDD," uV"
1140 PRINT USING 1130 ; W1
1150 IMAGE "BIAS",16X,DD.DDD," u
V"
1160 PRINT USING 1150 ; B1
1170 IMAGE "BIAS ST ERR ",8X,DD.
DDD," uV"
1180 PRINT USING 1170 ; W3
1190 PRINT USING 880
1200 IMAGE "RG ASSIGNED MEAN ",D
D.8D," V",/
1130 PRINT USING 1120 ; M
1210 PRINT USING 880
1220 IMAGE "TG MEAN",10X,DD.8D,"
V",/
1230 PRINT USING 1220 ; M2
1240 PRINT USING 880
1250 PRINT "RG"
1260 IMAGE DD,3X,3D.8D," V"
1270 FOR J=1 TO N1
1280 PRINT USING 1260 ; J,E(J)
1290 NEXT J
1300 PRINT USING 880
1310 PRINT "TG"
1320 FOR I=1 TO N2
1330 PRINT USING 1260 ; I,D(I)
1340 NEXT I
1350 END

```

8.09.21 FULL-DESIGN CROSS-COMPARISON PROGRAM.
TYPICAL PRINTOUT EXAMPLE

VOLT OUTPUT CROSS-COMPARISON
FULL DESIGN
DATE 10 JULY 1985
REFERENCE GROUP RG IS RG-A
TEST GROUP TG IS TG-A

GIVEN RG MEAN 1.01861580 V
OBSERVED DIFFERENCES & RESIDUALS
(uV)

FORWARD MEASUREMENTS (uV)

		OBS	RES
RG OUTPUT	1		
TG OUTPUT	1	-40.6	-.013
TG OUTPUT	2	-23.1	-.100

RG OUTPUT	2		
TG OUTPUT	1	-40.9	-.063
TG OUTPUT	2	-23.1	.150

RG OUTPUT	3		
TG OUTPUT	1	-57.4	.088
TG OUTPUT	2	-40.1	-.200

RG OUTPUT	4		
TG OUTPUT	1	-53.6	.213
TG OUTPUT	2	-36.3	-.075

SUM OF FORW RESIDUALS 0.000 uV
SUM OF REV RESIDUALS 0.000 uV
OBS ST DEV IS .140 uV BASED ON
10 DEGREES OF FREEDOM

TG OUTPUT ST ERR	.050 uV
RG OUTPUT ST ERR	.061 uV
BIAS	-.119 uV
BIAS ST ERR	.035 uV

TG MEAN 1.01865507 V

RG

1	1.01862339 V
2	1.01862314 V
3	1.01860649 V
4	1.01861017 V

TG

1	1.01866386 V
2	1.01864628 V

REVERSE MEASUREMENTS (uV)

		OBS	RES
RG OUTPUT	1		
TG OUTPUT	1	40.4	.050
TG OUTPUT	2	22.6	-.163

RG OUTPUT	2		
TG OUTPUT	1	40.7	.100
TG OUTPUT	2	23.0	-.013

RG OUTPUT	3		
TG OUTPUT	1	57.2	-.050
TG OUTPUT	2	39.6	-.063

RG OUTPUT	4		
TG OUTPUT	1	53.7	.125
TG OUTPUT	2	36.0	.013

8.09.30 HALF-DESIGN CROSS-COMPARISON PROGRAM.

```

10 REM VOLT-OUTPUT CROSS-COMPARI
SON-HALF-DESIGN
20 DISP "NO. REF OUTPUTS?"
30 INPUT N1
40 DISP "NO. TEST OUTPUTS?"
50 INPUT N2
60 DISP "NAME OF REF GROUP?"
70 INPUT A$
80 DISP "NAME OF TEST GROUP?"
90 INPUT B$
100 DISP "REF GROUP MEAN (V)?"
110 INPUT M
120 DISP "DATE OF MEASUREMENT"
130 INPUT C$
140 FOR I=1 TO N2
150 FOR J=1 TO N1
160 DISP "ROW ";I;" COLUMN ";J
170 INPUT Y(I,J)
180 NEXT J
190 NEXT I
200 REM IF BOTH N1,N2 ARE EVEN,
H=1;IF N1 IS ODD AND N2 IS EVEN,
H=2
210 REM IF N1 IS EVEN AND N2 IS
ODD,H=3;IF BOTH N1,N2 ARE ODD,
H=4
220 I1=(N1/2-INT(N1/2))*2
230 I2=(N2/2-INT(N2/2))*2
240 H=2*I2+I1+1
250 REM LEAST-SQUARES CALCULATIO
N BEGINS
260 FOR I=1 TO 4
270 P(I)=0
280 NEXT I
290 FOR I=1 TO N2
300 P2(I)=0
310 P3(I)=0
320 FOR J=1 TO N1
330 P(1)=P(1)+Y(I,J)
340 I3=I+J
350 P(2)=P(2)+Y(I,J)*(-1)^I3
360 P(3)=P(3)+Y(I,J)*(-1)^J
370 P(4)=P(4)+Y(I,J)*(-1)^I
380 P2(I)=P2(I)+Y(I,J)*(-1)^I3
390 P3(I)=P3(I)+Y(I,J)*(-1)^J
400 NEXT J
410 NEXT I
420 FOR J=1 TO N1
430 P1(J)=0
440 P4(J)=0
450 FOR I=1 TO N2
460 I3=I+J
470 P1(J)=P1(J)+Y(I,J)*(-1)^I3
480 P4(J)=P4(J)+Y(I,J)*(-1)^I
490 NEXT I
500 NEXT J
510 N3=N1^2-1
520 N4=N2^2-1
530 N5=N1*N2
540 F=N5-N1-N2
550 M1=1000000*M
560 IMAGE /
570 REM THE REF GROUP EMFS ARE D
ENOTED BY E'S AND THE TEST GROUP
EMFS BY D'S
580 FOR K=1 TO 10
590 K1(K)=(-1)^K
600 NEXT K
610 IF N2=1 THEN 620 ELSE 670
620 D(1)=M1+P3(1)/N1 @ FOR J=1 T
O N1
630 FOR J=1 TO N1
640 E(J)=D(1)-K1(J)*Y(1,J)
650 NEXT J
660 GOTO 720
670 IF N1=1 THEN 680 ELSE 740
680 E(1)=M1
690 FOR I=1 TO N2
700 D(I)=M1+K1(I)*Y(I,1)
710 NEXT I
720 IMAGE "INSUFFICIENT DATA FOR
EVALUATING STANDARD ERRORS"
730 GOTO 1480
740 IF H=1 THEN 780
750 IF H=2 THEN 1050
760 IF H=3 THEN 1200
770 IF H=4 THEN 1320
780 FOR J=1 TO N1
790 E(J)=M1-P(2)/N5+P1(J)/N2
800 NEXT J
810 FOR I=1 TO N2
820 D(I)=M1-P2(I)/N1
830 NEXT I
840 B=P(1)/N5
850 S1=0
860 Q1=0

```

8.09.30 HALF-DESIGN CROSS-COMPARISON PROGRAM (CONTINUED).

```

870 FOR J=1 TO N1
880 FOR I=1 TO N2
890 I3=I+J
900 R(I,J)=Y(I,J)-(E(J)-D(I))*(-
1)^I3-B
910 S1=S1+R(I,J)
920 Q1=Q1+R(I,J)^2
930 NEXT I
940 NEXT J
950 V=Q1/F
960 W=SQR(V)
970 IF H=1 THEN 1010
980 IF H=2 THEN 1160
990 IF H=3 THEN 1280
1000 IF H=4 THEN 1400
1010 V1=V/N5*(N1-1)
1020 V2=V/N1
1030 V3=V/N5
1040 GOTO 1480
1050 FOR J=1 TO N1
1060 E(J)=M1-P(2)/N5+P1(J)/N2
1070 B=(P(1)*N1+P(3))/(N2*N3)
1080 NEXT J
1090 FOR I=1 TO N2
1100 B1(I)=P3(I)+B
1110 B2(I)=B1(I)/N1
1120 C(I)=K1(I)*B2(I)
1130 D(I)=M1-C(I)
1140 NEXT I
1150 GOTO 850
1160 V1=V/N5*(N1-1)
1170 V2=V/N1*(1+1/(N2*N3))
1180 V3=V*N1/(N2*N3)
1190 GOTO 1480
1200 B=(P(1)*N2+P(4))/(N1*N4)
1210 FOR J=1 TO N1
1220 E(J)=M1+(P4(J)+B)/N2*(-1)^J
-P(2)/N5
1230 NEXT J
1240 FOR I=1 TO N2
1250 D(I)=M1-P2(I)/N1
1260 NEXT I
1270 GOTO 850
1280 V1=V/N2*(1-2/N1+N2^2/(N1*N3
))
1290 V2=V/N1
1300 V3=V*N2/(N1*N4)
1310 GOTO 1480
1320 B=(N5*P(1)+N1*P(4)+N2*P(3)+
P(2))/(N3*N4)
1330 FOR J=1 TO N1
1340 E(J)=M1-P(2)/N5+P1(J)/N2+(1
+(-1)^J*N1)*(B/N5)
1350 NEXT J
1360 FOR I=1 TO N2
1370 D(I)=M1-P2(I)/N1-(-1)^I*(B/
N1)
1380 NEXT I
1390 GOTO 850
1400 X=0
1410 FOR J=1 TO N1
1420 B3(J)=1-1/N1+(N1^2+1+2*N1*(
-1)^J)/(N1*N3*N4)
1430 V4(J)=V*B3(J)/N2
1440 X=X+V4(J)
1450 NEXT J
1460 V2=(1+N2/(N3*N4))*(V/N1)
1470 V3=V*N5/(N3*N4)
1480 IF F<2 THEN 1510
1490 W2=SQR(V2)
1500 W3=SQR(V3)
1510 S2=0
1520 FOR I=1 TO N2
1530 S2=S2+D(I)
1540 D(I)=D(I)/1000000
1550 NEXT I
1560 FOR J=1 TO N1
1570 E(J)=E(J)/1000000
1580 NEXT J
1590 S4=S2/N2/1000000
1600 IMAGE "VOLT OUTPUT CROSS-CO
MPARISON"
1610 PRINT USING 1600
1620 IMAGE "HALF-DESIGN"
1630 PRINT USING 1620
1640 IMAGE "DATE ",18A
1650 PRINT USING 1640 ; C$
1660 IMAGE "REFERENCE GROUP RG I
S ",8A
1670 PRINT USING 1660 ; A$
1680 IMAGE "TEST GROUP TG IS ",5
X,8A
1690 PRINT USING 1680 ; B$
1700 IMAGE "OBSERVED DIFFERENCES
& RESIDUALS (UV)"
1710 IMAGE "OBSERVED DIFFERENCES
(UV)"
1720 IMAGE 16X,"OBS",5X,"RES"
1730 IMAGE 16X,"OBS"
1740 IMAGE "RG OUTPUT ",DD
1750 IMAGE "TG OUTPUT ";DD,5D.D,
4D.DDD
1760 IMAGE "TG OUTPUT ",DD,5D.D
1770 IF F<2 THEN 1880
1780 PRINT USING 1700
1790 PRINT USING 1720
1800 FOR J=1 TO N1
1810 PRINT USING 1740 ; J
1820 FOR I=1 TO N2
1830 PRINT USING 1750 ; I,Y(I,J)
,R(I,J)
1840 NEXT I
1850 PRINT USING 560
1860 NEXT J

```

8.09.30 HALF-DESIGN CROSS-COMPARISON PROGRAM (CONTINUED).

```
1870 GOTO 1990
1880 PRINT USING 1710
1890 PRINT USING 1730
1900 FOR J=1 TO N1
1910 PRINT USING 1740 ; J
1920 FOR I=1 TO N2
1930 PRINT USING 1760 ; I,Y(I,J)

1940 NEXT I
1950 PRINT USING 560
1960 NEXT J
1970 PRINT USING 720
1980 GOTO 2180
1990 PRINT USING 560
2000 IMAGE "SUM OF RESIDUALS IS
",D.DDD," UV"
2010 PRINT USING 2000 ; S1
2020 IMAGE "OBS ST DEV IS",2D.DD
D," UV BASED ON ",2D," DEGREES O
F FREEDOM"
2030 PRINT USING 2020 ; W,F
2040 IMAGE "TG OUTPUTS ST ERR ",
2D.DDD," UV"
2050 PRINT USING 2040 ; W2
2060 IF H=4 THEN 2110
2070 W1=SQR(V1)
2080 IMAGE "RG OUTPUTS ST ERR ",
2D.DDD," UV"
2090 PRINT USING 2080 ; W1
2100 GOTO 2140

2110 FOR J=1 TO N1
2120 W4=SQR(X/N1)
2130 PRINT USING 2080 ; W4
2140 IMAGE "BIAS",11X,DD.DDD," U
V"
2150 IMAGE "BIAS ST ERR ",3X,DD.
DDD," UV"
2160 PRINT USING 2140 ; B
2170 PRINT USING 2150 ; W3
2180 PRINT USING 560
2190 IMAGE "RG ASSIGNED MEAN ",
DD.8D," V"
2200 PRINT USING 2190 ; M
2210 PRINT USING 560
2220 IMAGE "TG MEAN", 10X,
DD.8D," V"
2230 PRINT USING 2220 ; S4
2240 PRINT USING 560
2250 IMAGE " RG"
2260 PRINT USING 2250
2270 IMAGE DD,1X,3D.8D ," V"
2280 FOR J=1 TO N1
2290 PRINT USING 2270 ; J,E(J)
2300 NEXT J
2310 PRINT USING 560
2320 IMAGE " TG"
2330 PRINT USING 2320
2340 FOR I=1 TO N2
2350 PRINT USING 2270 ; I,D(I)
2360 NEXT I
2370 END
```

8.09.30 HALF-DESIGN CROSS-COMPARISON PROGRAM.
TYPICAL PRINTOUT EXAMPLE

VOLT OUTPUT CROSS-COMPARISON
HALF-DESIGN
DATE 10 JULY 1985
REFERENCE GROUP RG IS RG-B
TEST GROUP TG IS TG-B
OBSERVED DIFFERENCES & RESIDUALS
(UV)

		OBS	RES
RG OUTPUT	1		
TG OUTPUT	1	-8.4	-.158
TG OUTPUT	2	8.4	.025
TG OUTPUT	3	-8.1	.017
TG OUTPUT	4	8.8	.100
TG OUTPUT	5	-7.6	.217
TG OUTPUT	6	8.6	-.050

SUM OF RESIDUALS IS -.000 UV
OBS ST DEV IS .112 UV BASED ON
14 DEGREES OF FREEDOM
TG OUTPUTS ST ERR .056 UV
RG OUTPUTS ST ERR .040 UV
BIAS .192 UV
BIAS ST ERR .023 UV

RG OUTPUT	2		
TG OUTPUT	1	8.1	-.092
TG OUTPUT	2	-7.6	-.042
TG OUTPUT	3	8.1	.033
TG OUTPUT	4	-7.9	-.017
TG OUTPUT	5	7.7	-.067
TG OUTPUT	6	-7.9	-.067

RG ASSIGNED MEAN 1.01861296 V

TG MEAN 1.01862087 V

RG OUTPUT	3		
TG OUTPUT	1	-7.5	.025
TG OUTPUT	2	7.7	.042
TG OUTPUT	3	-7.4	.000
TG OUTPUT	4	7.9	-.083
TG OUTPUT	5	-7.2	-.100
TG OUTPUT	6	7.9	-.033

RG	
1	1.01861255 V
2	1.01861299 V
3	1.01861327 V
4	1.01861304 V

RG OUTPUT	4		
TG OUTPUT	1	8.1	-.042
TG OUTPUT	2	-7.4	.108
TG OUTPUT	3	8.0	-.017
TG OUTPUT	4	-7.8	.033
TG OUTPUT	5	7.9	.183
TG OUTPUT	6	-7.8	-.017

TG	
1	1.01862099 V
2	1.01862074 V
3	1.01862086 V
4	1.01862106 V
5	1.01862056 V
6	1.01862101 V

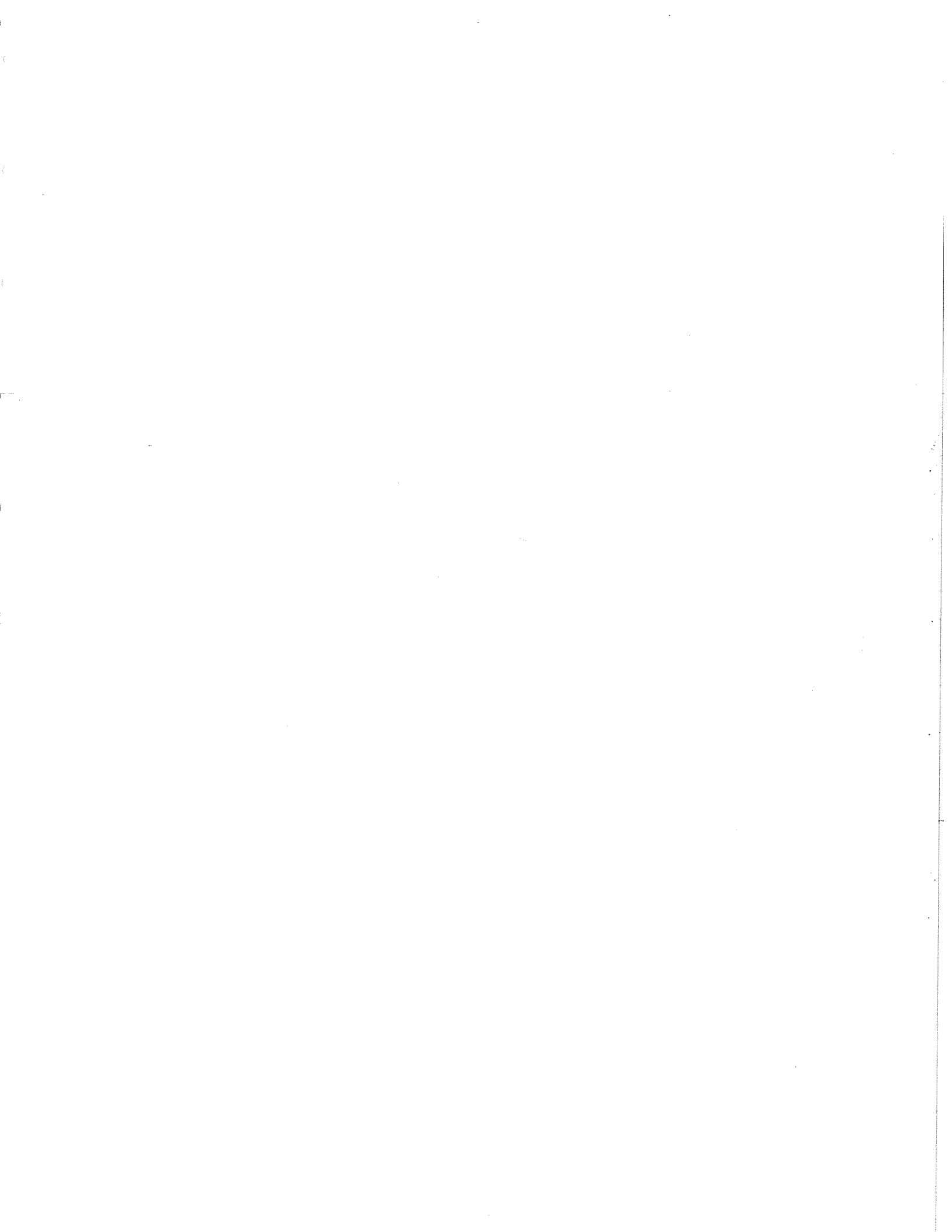

- 9.00.00 TROUBLE SHOOTING
- 9.00.01 The instrument carries a warranty, and consequently user repairs are not recommended.
- 9.01.00 LINE INDICATOR FAILS TO LIGHT
No line power at outlet - check outlet
Power switch not ON - check switch position
Line fuse open circuit - check fuses
THE FOLLOWING ARE FAULTS - see 9.00.01
Transformer - check at TX1.1 secondary
Bridge - check at C1.1 for about 20V
Regulator - check at D2.1 anode
Resistor or LEDS - R2.1, LED7.3, LED 8.3
- 9.02.00 FAST CHARGE INDICATOR FAILS TO LIGHT
As above, 9.01.00
Battery is nearly fully charged
Battery is disconnected or faulty
THE FOLLOWING ARE FAULTS - see 9.00.01
Network Q1.1,R4.1,R5.1,R6.1,LED6.3
- 9.03.00 LOW BATTERY VOLTAGE INDICATOR FAILS TO FLASH
Battery voltage is above 11.6V
Battery is disconnected or below 5V
THE FOLLOWING ARE FAULTS - see 9.00.01
Battery low voltage monitor faulty, see 3.04.12
- 9.04.00 NO INDICATION OF OVEN TEMPERATURE
Transit switch activated
Battery below 6V and no line power
THE FOLLOWING ARE FAULTS - see 9.00.01
Oven monitor circuit faulty - 3.04.11
Note: Oven CONTROL fault will not cause above
- 9.05.00 OVEN TEMP INDICATES HIGH OR LOW
Ambient outside controllable range
Insufficient settling time
THE FOLLOWING ARE FAULTS - see 9.00.01
Faulty oven control - 3.03.00
- 9.06.00 OVEN TEMP INDICATOR CHANGING - HI, LO, OK
Insufficient settling time
Severely changing environment
THE FOLLOWING ARE FAULTS - see 9.00.01
Faulty oven control - 3.03.00

- 9.07.00 NO OUTPUT VOLTAGE ON ANY OUTPUT
Battery low or disconnected
Excessive load on one or more output
THE FOLLOWING ARE FAULTS - see 9.00.01
Current limiting circuit fault - see 3.04.13
Faulty reference module - TO GUILDLINE
- 9.08.00 APPARENTLY EXCESSIVE TEMPERATURE COEFFICIENT
Thermal emf, particularly 1.018V outputs
Ambient outside controllable range - oven indicator
Low battery voltage, check battery voltage monitor
THE FOLLOWING ARE FAULTS - see 9.00.01
Faulty reference module - TO GUILDLINE
- 9.09.00 APPARENTLY EXCESSIVE NOISE
Pickup in leads - see 5.00.00
Poor connections - see 5.00.00
Fluctuating thermal emf's - see 5.00.00
THE FOLLOWING ARE FAULTS - see 9.00.01
Faulty reference module - TO GUILDLINE
- 9.10.00 APPARENTLY EXCESSIVE DRIFT
Measurement technique - covered in detail elsewhere
The specified limit implies that any one output may change up to the sum of the + and - limits in relation to any other over a year. Drift worse than TYPICAL may be reported. The NML, NBS, or NPL shall be the authority on drift.
THE FOLLOWING ARE FAULTS - see 9.00.01
Faulty reference module - TO GUILDLINE
- 9.11.00 BATTERY APPARENTLY DISCONNECTED
Battery actually disconnected
Battery voltage lower than 4V
"Fuse" - thermistor RT1.3 latched open
THE FOLLOWING ARE FAULTS - see 9.00.01
Wiring fault
- 9.12.00 THERMISTOR RT1.3 OPENED
Restore by disconnecting battery and re-connecting with line switched off
Caused by either Battery connected reversed or -
THE FOLLOWING ARE FAULTS - see 9.00.01
Support electronics fault - see 3.04.00

ACCESSORIES	35
ADJUSTMENTS	37
ANNUAL DRIFT	34
BATTERY CHARGER	11
BATTERY CHARGER ADJUSTMENT	37
BATTERY CHARGER LAYOUT	12
BATTERY CHARGER PARTS LIST	12
BATTERY CHARGER SCHEMATIC	12
BATTERY OPERATION, SPECIFICATION	35
BATTERY STATUS INDICATOR	26
CERTIFICATION PROCEDURE	36
CERTIFICATION, SUITABILITY	7
CHARGER, BATTERY see battery charger	
CIRCUIT DESCRIPTION, BATTERY CHARGER	11
CIRCUIT DESCRIPTION, OVEN	13
CIRCUIT DESCRIPTION, REFERENCE MODULE	20
CIRCUIT DESCRIPTION, SUPPORT ELECTRONICS.	15
COMPARISON BY BACK TO BACK MEASUREMENTS	31
COMPARISON BY SUBSTITUTION	30
COMPARISON WITH STANDARD CELLS	30
COMPONENTS, INTERNAL LAYOUT	10
CONFIDENCE RANGES	57
CONTROL, OVEN	13
CROSS-COMPARISON, FULL DESIGN	48
CROSS-COMPARISON, FULL DESIGN PRINTOUT	63
CROSS-COMPARISON, FULL DESIGN PROGRAM.	61
CROSS-COMPARISON, HALF DESIGN	52
CROSS-COMPARISON, HALF DESIGN PRINTOUT	67
CROSS-COMPARISON, HALF DESIGN PROGRAM.	64
CROSS-COMPARISON, DEFINITION	43
DEFINITION, INTER AND CROSS COMPARISON	43
DESIGN IMPLIMENTATION	8
DESIGN PHILOSOPHY	3
DIAGRAM, BLOCK	9
DIMENSIONS	35
DRIFT, ANNUAL	34
DRIFT, SPECIFICATION	34
EXTERNAL BATTERY OPERATION	4
HYSTERESIS	34
INTERCOMPARISON PROGRAM	59
INTERCOMPARISON PROGRAM PRINTOUT EXAMPLE.	60
INTERCOMPARISON, DEFINITION	43
INTERCONNECTIONS.	29
INTERNAL COMPONENT LAYOUT.	10
INTRODUCTION	2
ISOLATION, AC.	35

LAYOUT, BATTERY CHARGER	12
LAYOUT, INTERNAL COMPONENTS	10
LAYOUT, OVEN CONTROL	14
LAYOUT, SUPPORT ELECTRONICS	18
LEAKAGE, SPECIFICATION.	35
LINE FILTER	27
LINE FUSE	27
LINE IMMUNITY.	34
LINE INDICATOR	25
LINE VOLTAGE CHANGEOVER SWITCH	27
LOW VOLTAGE TRIP ADJUSTMENT	37
MATERIALS ACCEPTANCE	23
MONITOR, EXTERNAL TEMPERATURE	27
NOISE	6
NOISE, SECIFICATION.	34
OPERATION	24
OUTPUT RESISTANCE ESTIMATION.	38
OUTPUT TERMINALS.	26
OUTPUTS INDICATOR	25
OUTPUTS, MULTIPLE	6
OUTPUTS, STATISTICAL USE OF	39
OVEN CONTROL	13
OVEN CONTROL PARTS LIST	14
OVEN CONTROL, LAYOUT	14
OVEN CONTROL, SCHEMATIC	14
OVEN STATUS	24
PARTS LIST, BATTERY CHARGER	12
PARTS LIST, MECHANICAL	10
PARTS LIST, OVEN CONTROL	14
PARTS LIST, REFERENCE MODULE	22
PARTS LIST, SUPPORT ELECTRONICS	19
PORTABILITY	5
POWER REQUIREMENT	35
POWER SWITCH	27
PRE-REGULATOR ADJUSTMENT	38
PROGRAMS FOR STATISTICAL ANALYSIS	59
RANGES, CONFIDENCE	57
REFERENCE MODULE.	20
REFERENCE MODULE CIRCUIT DESCRIPTION	20
REFERENCE MODULE PARTS LIST	22
REFERENCE MODULE SCHEMATIC	21

SCHEMATIC, BATTERY CHARGER	12
SCHEMATIC, BLOCK.	9
SCHEMATIC, OVEN CONTROL	14
SCHEMATIC, REFERENCE MODULE	21
SCHEMATIC, SUPPORT ELECTRONICS	17
SHIELDING	29
SIGN CONVENTION	44
SPECIFICATIONS, PERFORMANCE	34
STABILITY	4
STATISTICAL USE OF THE OUTPUTS	39
STATISTICS BACKGROUND	40
STATISTICS INTRODUCTION	39
SUPPORT ELECTRONICS	15
SUPPORT ELECTRONICS CIRCUIT DESCRIPTION	15
SUPPORT ELECTRONICS LAYOUT	18
SUPPORT ELECTRONICS PARTS LIST	19
SUPPORT ELECTRONICS SCHEMATIC	17
SWITCH, LINE VOLTAGE CHANGEOVER	27
TEMPERATURE COEFFICIENT	34
TEMPERATURE MONITOR, EXTERNAL	27
TERMINALS, OUTPUT	26
TESTING PROCEDURE, MATERIALS.	23
TRANSIT SWITCH	24
TROUBLE SHOOTING	69
OVEN.	24
USE OF 4410 FOR CALIBRATING	28
USER FRIENDLY.	5
WEIGHT	35