

Chroma[®]

**AC SOURCE
6404 / 6408**

User's Manual

Warranty

All Chroma instruments are warranted against defects in material and workmanship for a period of one year after date of shipment. Chroma agrees to repair or replace any assembly or component found to be defective, under normal use during this period. Chroma's obligation under this warranty is limited solely to repairing any such instrument which in Chroma's sole opinion proves to be defective within the scope of the warranty when returned to the factory or to an authorized service center. Transportation to the factory or service center is to be prepaid by purchaser. Shipment should not be made without prior authorization by Chroma.

This warranty does not apply to any products repaired or altered by persons not authorized by Chroma, or not in accordance with instructions furnished by Chroma. If the instrument is defective as a result of misuse, improper repair, or abnormal conditions or operations, repairs will be billed at cost.

Chroma assumes no responsibility for its product being used in a hazardous or dangerous manner either alone or in conjunction with other equipment. High voltage used in some instruments may be dangerous if misused. Special disclaimers apply to these instruments. Chroma assumes no liability for secondary charges or consequential damages and in any event, Chroma's liability for breach of warranty under any contract or otherwise, shall not exceed the purchase price of the specific instrument shipped and against which a claim is made.

Any recommendations made by Chroma for use of its products are based upon tests believed to be reliable, but Chroma makes no warranty of the results to be obtained. This warranty is in lieu of all other warranties, expressed or implied, and no representative or person is authorized to represent or assume for Chroma any liability in connection with the sale of our products other than set forth herein.

CHROMA ATE INC.

43 Wu-Chuan Road, Wu-Ku,

Taipei, Taiwan

Tel: 886 -2-298-3855

Fax: 886-2-298-3596

Table of Contents

WARRANTY	
TABLE OF CONTENTS.....	
1. PRODUCT OVERVIEW	1
1.1 Introduction	1
1.2 Key Features	1
1.3 Specifications.....	1
1.4 Operational Panels	1
1.4.1 Front Panel	1
1.4.2 Rear Panel.....	1
2. INSTALLATION	2
2.1 Inspection	2
2.2 Preparation for Use	2
2.3 Input Power Requirements.....	2
2.3.1 Ratings.....	2
2.3.2 Input Connection	2
2.4 Output Connection	2
2.5 Remote Sense Connection.....	2
2.6 Power-on Procedure.....	2
2.7 I/O Connectors (Option).....	2
3. LOCAL OPERATION	3
3.1 Introduction	3
3.2 Set up	3
3.2.1 GPIB address	3
3.2.2 RS-232C	3
3.2.3 OVP	3
3.2.4 Sound (ON/OFF).....	3
3.2.5 System test.....	3
3.3 Output Setting and Execution	3
3.3.1 I limit	3
3.3.2 Range.....	3

3.3.3 Output V and F	3-5
3.4 Save and Recall	3-6
3.5 Data Lock	3-6
3.6 Ext Prog.....	3-7
3.7 Measurement.....	3-7
3.7.1 Select Measurement Items	3-8
3.7.2 Measurement Functions.....	3-8
3.8 Local.....	3-8
3.9 Protection	3-9
4. THEORY OF OPERATION	4-1
4.1 General	4-1
4.2 Overall System Description.....	4-1
4.3 AC/DC Power Stage Converter	4-2
4.4 DC/AC Inverter	4-2
4.5 CPU.....	4-3
4.6 Measurement and Sine wave Generator (B Board).....	4-3
4.7 Keyboard and Display.....	4-3
4.8 GPIB/RS-232C/External reference	4-3
5. SELF-TEST AND TROUBLESHOOTING.....	5-1
5.1 General	5-1
5.2 Self-test Routine.....	5-1
5.3 Troubleshooting	5-2
6. REMOTE OPERATION.....	6-1
6.1 General Information.....	6-1
6.2 GPIB Capability of the AC Source	6-1
6.3 Introduction to Programming	6-2
6.3.1 Conventions.....	6-2
6.3.2 Numerical Data Formats.....	6-2
6.3.3 Boolean Data Format.....	6-3
6.3.4 Character Data Format.....	6-3

6.3.5 Basic Definition	6-3
6.4 Traversal of the Command Tree	6-4
6.5 Execution Order	6-5
6.6 The AC Source Commands.....	6-5
6.6.1 Command Tree Table	6-5
6.6.2 Command Dictionary	6-7
6.7 Status Reporting	6-19
6.7.1 Questionable Status	6-19
6.7.2 Standard Event Status	6-20
6.7.3 Status Byte Register.....	6-20
6.8 Error Messages	6-21

CE-Conformity Declaration

For the following equipment:

Product Name: Programmable AC Source

Model Name: 6404, 6408

Manufacturer's Name: Chroma ATE Inc.

Manufacturer's Address: 43 Wu-Chuan Road, Wu-Ku Industrial Park,
Wu-Ku, Taipei Hsien, Taiwan

is herewith confirmed to comply with the requirements set out in the Council Directive on the Approximation of the Laws of the Member States Relating to Electromagnetic Compatibility(89/336/EEC) and electrical equipment designed for use within certain voltage limits.(73/23/EEC; 93/68/EEC)

For electromagnetic compatibility, the following standards were applied:

EMC: EN55011:1991 (Group I Class A)
EN60555-2:1987
EN60555-3:1987
EN50082-1:1992 IEC 801-2: 1991 - 8 kV AD
IEC 801-3:1984 - 3 V/m
IEC 801-4:1988 - 0.5 kV Signal Lines
1 kV Power Lines

For safety requirement , the following standard was applied:

Safety: EN 61010-1 (1993) + A2 (1995)

Taiwan

Jan, 1997

Neng Sung Lee

Place

Date

Neng-Sung Lee / Vice-President, Engineering

Warning

This is a class A product. In a domestic environment this product may cause radio interference in which case the user may be required to take adequate measures.

SAFETY SUMMARY

The following general safety precautions must be observed during all phases of operation , service and repair of this instrument. Failure to comply with these precautions or with specific WARNINGS given elsewhere in this manual violates safety standards of design , manufacture , and intended use of the instrument.

Chroma Electric Corporation assumes no liability for the customer's failure to comply with these requirements.

BEFORE APPLYING POWER

Verify that the product is set to match the line voltage.

PROTECTIVE GROUNDING

Make sure to connect the protective grounding to prevent an electric shock before turning on the power.

NECESSITY OF PROTECTIVE GROUNDING

Never cut off the internal or external protective grounding wire or disconnect the wiring of protective grounding terminal. Doing so will cause a potential shock hazard that could result in personal injury.

FUSES

Only fuses with the required rated current , voltage , and specified type (normal blow , time delay , etc.) should be used. Do not use different fuses or short-circuited fuseholders. To do so could cause a shock or fire hazard.

DO NOT OPERATE IN AN EXPLOSIVE ATMOSPHERE



Do not operate the instrument in the presence of flammable gases or fumes.

DO NOT REMOVE THE INSTRUMENT COVER

Operating personnel must not remove instrument covers. Component replacement and internal adjustments must be made only by qualified service personnel.

WARNING	LETHAL VOLTAGES. Ac sources can supply 426 V peak at their output. DEATH on contact may result if the output terminals or circuits connected to the output are touched when power is applied.
----------------	---

SAFETY SYMBOLS

	DANGER - High voltage .
	Explanation : To avoid injury , death of personnel or damage to the instrument , the operator must refer to an explanation in the instruction manual
	Protective grounding terminal : To protect against electrical shock in case of a fault. This symbol indicates that the terminal must be connected to ground before operation of equipment.
WARNING	A WARNING sign denotes a hazard. It calls attention to a procedure , practice condition or the like , which , if not correctly performed or adhered to , could result in injury or death of personnel.

ACOUSTIC NOISE INFORMATION

This product has a sound pressure emission (at the operator position) < 65dB(A)

1. Product Overview

1.1 Introduction

The Chroma 6400 series products, including 6408 and 6404, are high efficiency AC power sources which provide sine wave output with low distortion. The microprocessor controlled sine wave oscillator generates accurate and stable output voltages and frequencies. The PWM (Pulse Width Modulation) approach of the power stage allows for full volt — ampere and current rating into loads. The 6408 can supply up to 800 VA, the 6404, up to 375 VA. The accurate DSP (Digital Signal Processing) measurement capabilities provide independent verification of operating values, thus reducing the need for external measuring instruments.

The 6408/6404 series AC power source is considerably smaller, lighter and more efficient than traditional supplies with a similar output power capability.

This menu contains a description of the Chroma 6408/6404 programmable AC source, including specifications, installation procedure, operation instructions and maintenance procedures.

1.2 Key Features

A. Configuration

- Local operation on front panel keypad.
- Remote operation via GPIB or RS232 interface.
- Protections against Over-power, Over-current, Over-temperature, Under-voltage, Fan-fail.
- Temperature controlled fan speed.
- Built-in output isolation relays.

B. Input / Output

- Selectable full scale output : 150V/300V/Auto.
- Remote control using analog voltage reference.
- V, F, PF , CF, I, P measurement.
- Programmable limit of output I_{pk}.

1.3 Specifications

The operation specifications of the model 6408/6404 are listed in this section. All specifications are according to standard Chroma test procedures.

(All specifications are based on $25 \pm 1^\circ\text{C}$ resistor load unless specified otherwise).

	6404	6408-1	6408-2
OUTPUT			
Max. power	375VA	800VA	800VA
Voltage			
Range	150V/300V/Auto		
Accuracy	0.2 % of F.S. (for freq. \leq 200Hz) 0.4 % of F.S. (for freq. $>$ 200Hz)		
Resolution	0.1V		
Temp. coeff.	0.02 % per degree from 25°C		
Current			
Range	2.5A / 1.25A	5.33A / 2.67A	5.33A / 2.67A
C.F.	typical 2.8 for freq. \leq 100Hz typical 2.2 for freq. $>$ 100Hz		
Frequency			
Range	45 to 500 Hz		
Accuracy	0.1%		
Resolution	0.1Hz		
Temp. coeff.	50 ppm/ $^\circ\text{C}$ from 25°C		
Distortion	typical 0.3% (\leq 200Hz) typical 0.8 % for freq. $>$ 200Hz		
Line regulation	0.02% F.S. (\leq 200Hz) 0.1 % F.S. ($>$ 200Hz)		
Load regulation	0.1% F.S.		
INPUT			
Voltage Range	90 - 132V & 180 - 250V	90 - 132V	180 - 250V
Current	7 A max.	12 A max.	6 A max.
Frequency range	47 - 63 Hz		
Power factor	typical 0.8	0.98 min.	0.98 min.
EFFICIENCY	typical 80%		
MEASUREMENT			
Voltage			
Range	0-150V / 0-300V		
Accuracy (rms)	0.1% F.S. +0.1% reading		
Resolution	0.1V		

Current			
<i>Range</i>	0 to 2 A 2 to 10 A	0 to 4 A 4 to 20 A	0 to 4 A 4 to 20 A
<i>Accuracy</i>	0.2% F.S. + 0.5% reading		
<i>Resolution</i>	0.01A		
True Power			
<i>Range</i>	0-375W	0-800W	0-800W
<i>Accuracy</i>	0.5% F.S.		
<i>Resolution</i>	0.1 Watt		
EMI REQUIREMENT	FCC 15J class A, CE		
PROTECTION	UVP,OLP,SHT,OPP,OTP,FAN		
OTHERS			
<i>Size (W × H × D)</i>	483 × 134 × 468 mm ³		
<i>Weight</i>	18 Kg	23 Kg	23 Kg
Temperature range			
<i>Operation</i>	0 to +40 °C		
<i>Storage</i>	- 40 °C to +85 °C		
<i>Humidity</i>	30 % to 90 %		

Remark

*1 : Maximum distortion for voltage ranges from half to full range with linear load.

*2 : These items are tested with full power linear load.

1.4 Operational Panels

1.4.1 Front Panel

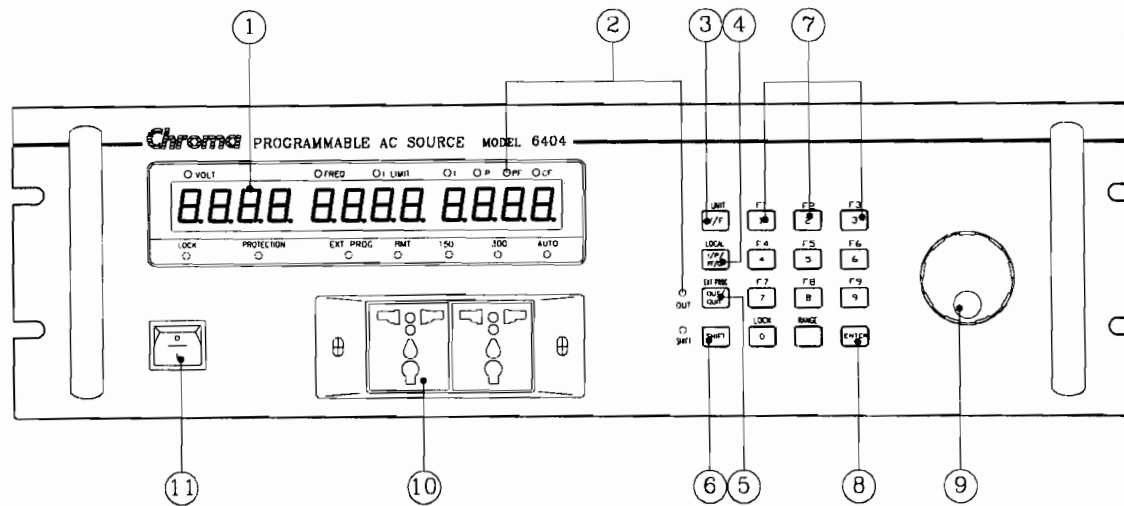



Table 1-1 Front Panel Description

Item	Symbol	Description
1		Alphanumeric LED : A row of red seven-segment LEDs are equipped for displaying setup messages and numeric value of settings or measurement results. The display area is divided into three sections; value of V shows on the left, frequency or I limit, in the middle, and any of I/P/PF/CF measurement value, on the right.
2		Indicator LED : LEDs located on the upper and lower part of the display panel are the indicators for showing the status being activated. These indicators include "VOLT", "FREQ", "I LIMIT", "I", "P", "PF", "CF", "LOCK", "PROTECTION", "EXT PROG", "RMT", "150V", "300V", "AUTO". Besides, two LEDs, "OUT" and "SHIFT", for showing activation of output and shift mode, are available which are located on the keypad area next to the corresponding keys.
3	<div style="text-align: center;"> V/F ----- or ----- I limit </div>	V/F or I limit selection key : Under normal mode, the V/F key offers the user selection of programming on voltage or frequency. Under shift mode, this key enables the user to program software limit to the output peak current.
	<div style="text-align: center;"> I/P/PF/CF </div>	I/P/PF/CF selection key : Under normal mode, the user can repeatedly press this key to select one of the measurement values to be displayed. Under shift

4	<p>----- or -----</p> <p style="text-align: center;">LOCAL</p>	<p>mode, this key provides the user for returning controls from remote PC to front panel keypad.</p>
5	<p style="text-align: center;">OUT/QUIT</p> <p>----- or -----</p> <p style="text-align: center;">EXT PROG</p>	<p>OUT/QUIT command key : Under normal operation, presses of this key may enable the 6408/6404 outputs power to the loading devices. If the user enters setup procedures, this key is used to quit from current setting routine. Under shift mode, this key enables external programming.</p>
6	<p style="text-align: center;">SHIFT</p>	<p>Shift mode selection key : Press this key switches the 6408/6404 from the normal operational mode to the shift mode, or from shift back to normal.</p>
7	<p>1 to 9, 0 and .</p> <p>----- or -----</p> <p>F1 to F9,</p> <p>LOCK, and</p> <p>RANGE</p>	<p>Numeric and decimal keys : Under normal mode, the user can program numeric data using the digital keys and the decimal key. Under shift mode, the keys from 1 to 9 saves data to or recalls them from memory channels F1 to F9 respectively. Additionally, under shift mode, 0 enables data lock and configuration setup , and . offers programming of the full range of output voltage.</p>
8	<p style="text-align: center;">ENTER</p>	<p>The ENTER key is to confirm setting of parameters.</p>
9		<p>Rotary knob : The user may input programming data or options by turning the rotary knob to the desired ones.</p>
10		<p>Universal Output connectors : These connectors output power to the loads.</p>
11		<p>Main Power switch : Power on/off the 6408/6404 by using this switch.</p>

1.4.2 Rear Panel

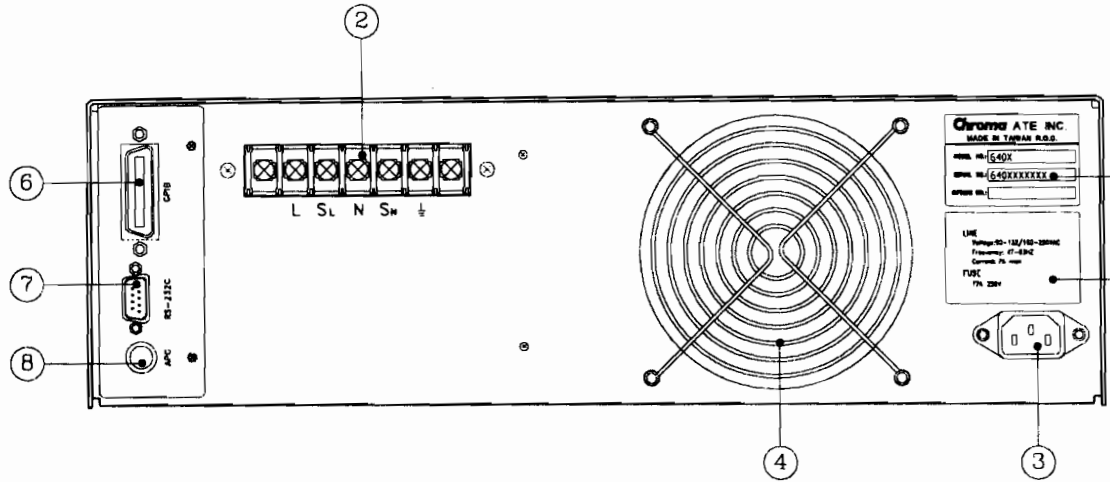

Table 1-2 Rear Panel Description

Item	Name	Description
1	Product Label	The model number 6408 or 6404 and power line input ratings are marked on the label.
2	Terminal Block	Power line output is connected to the 6408/6404 through this connector and the outlet at the front panel.
3	Power Line input connector	Power line input is connected to the 6408/6404 through this connector.
4	Cooling Fan	Cooling fan speed automatically increases or decreases as temperature rises or falls.
5	Series No. Label	Each set of the 6408/6404 instruments has its own identification number marked on this label.
6	GPIB connector	The optional interface provided by the 6408/6404 is to communicate with the remote GPIB controller.
7	RS-232C connector	This port located on the same GPIB optional board offers an alternate interface to the 6408/6404 for remote operation.
8	Ext. V Ref.	Control the output Vrms of the 6408/6404 by using external DC voltage level. Such signal is input through this BNC connector. This connector is on the same optional board as items 6 and 7.

2. Installation

2.1 Inspection

When unpacking the instrument, inspect for any damage that may have occurred in shipping. Save all packing materials in case the unit has to be returned.

If any damage is found, please file a claim with the carrier immediately. Do not return the instrument to the factory without prior RMA acceptance from Chroma.

2.2 Preparation for Use

To start up, the instrument must be connected with an appropriate AC line input. The instrument is smart fan cooled and must be installed with sufficient space to the rear for air flow. It should be used in an area where the ambient temperature does not exceed +40 °C.

2.3 Input Power Requirements

2.3.1 Ratings

Input Voltage Range	6408-1	: 90 ~ 132 Vac, single phase.
	6408-2	: 180 ~ 250 Vac, single phase.
	6404	: 90 ~ 132 Vac, 180 ~ 250 Vac (auto range), single phase.
Input Frequency	47-63 Hz	
Max. Current	6408-1	: 12 A
	6408-2	: 6 A
	6404	: 7 A
Max. Power	6408-1	: 1100 W
	6408-2	: 1100 W
	6404	: 500 W

2.3.2 Input Connection

The input power inlets are located on the rear panel of the instrument. Refer to Figure 2-1. Input of the 6408/6404 must be connected from a three-wire single phase AC power outlet. The power line input must have a current rating greater than or equal to the instrument fuse current rating.

**** WARNING ****

To protect operating personnel, the wire connected to the GND terminal must be connected to an earth ground. In no event should this instrument be operated without an adequate ground connection.

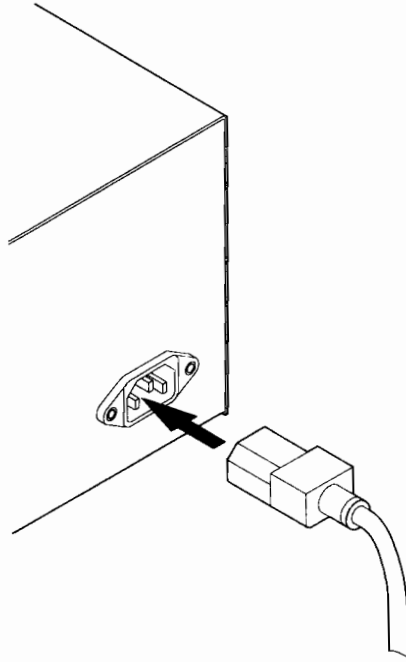

Fig 2-1 Input Connection

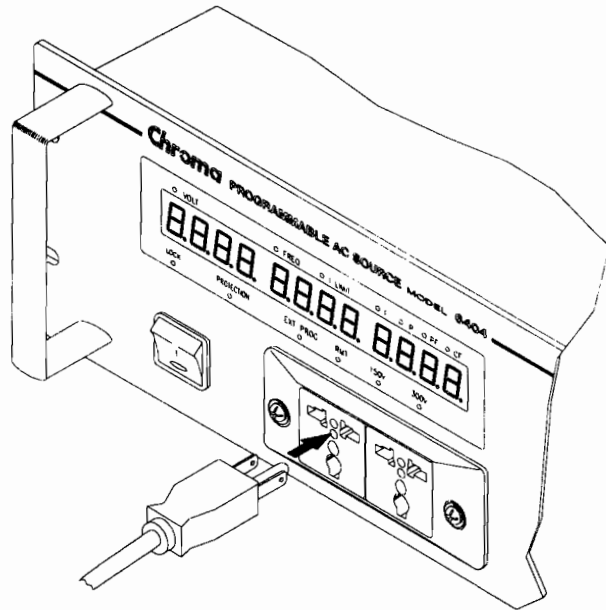

Fig 2-2a Output Connection

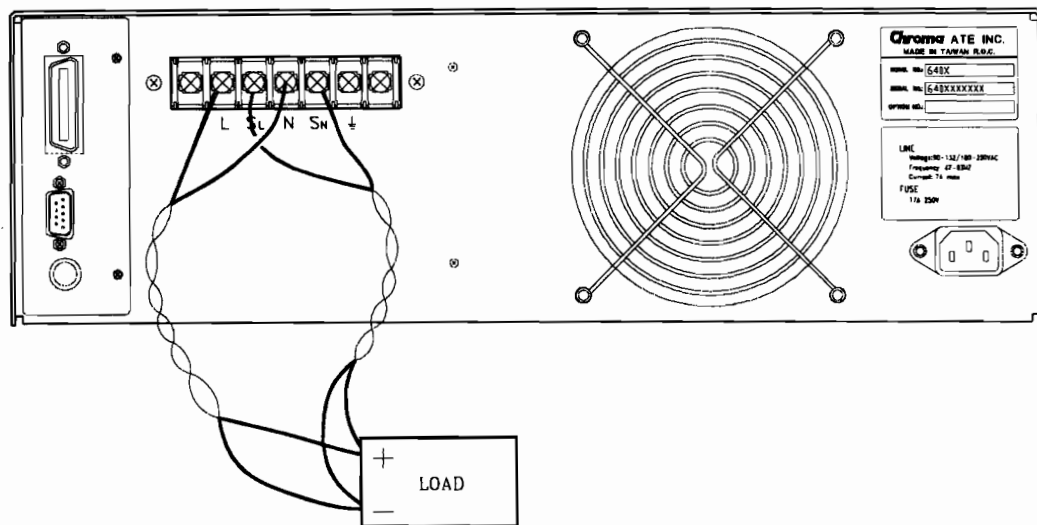

Fig 2-2b Output Connection

2.4 Output Connection

Output power can be connected from the terminal block located at the rear panel of the instrument through terminals L and N to the load. Besides, it can be connected from the universal receptacle located at the front panel using power cord to the load. To satisfy safety requirements, the wires to the load should be of a sufficiently large gauge to insure they do not overheat while carrying the output current. Refer to Figure 2-2a and 2-2b.

2.5 Remote Sense Connection

The remote sensing connections improves the voltage regulation at the load by monitoring the voltage there instead of at the AC source output terminal. Remote Sensing allows the power supply to automatically increase the output voltage and compensate the voltage drops in the load leads. Note that with remote sensing, voltage read-back is at the load.

Connect the unit for remote voltage sensing by connecting load leads from the output terminals to the load, and the sensing leads from the S_L and S_N terminals to the load as shown in Figure 2-2b.

2.6 Power-on Procedure

Apply the line power and turn on the front panel power switch. No loads should be connected to the output terminal block. The instrument performs a series of self tests each time when turning on the power-switch. All front panel LEDs, including alphanumeric and indicator LEDs, are turned on and holds about 3 seconds. Then, the

seven segment LEDs, alphanumeric LEDs will show "SELF TEST" indicating that the 6408/6404 is running test routines.

Then, the seven segment LEDs display model number (6408 or 6404), firmware version number (e.g. "ver") as below :

6408 ver 1.2

If any error is detected during the self-test routine, an error message will be displayed on the LED. For example:

RAM TEST ERR

The following table shows all the error messages and recommended actions :

Item	Error Message	Description	Action
1	RAM TEST ERR	System memory test failure.	Consult your dealer for assistance, in case of self-test failure.
2	EEPROM ERR	System EEPROM test failure.	
3	DSP COMM ERR	CPU and DSP communication test failure.	

After the self-test routines are completed the LEDs turn to show the current setting values of V and measured value of I, indicating the 6408/6404 is ready for use as below :

0.0 60.0 0.00

**** WARNING ****

Before the instrument is turned on, all protective earth terminals, extension cords, and devices connected to the instrument should be connected to a protective earth ground. Any interruption of the protective earth ground will cause a potential shock hazard that could result in personal injury.

2.7 I/O Connectors (Option)

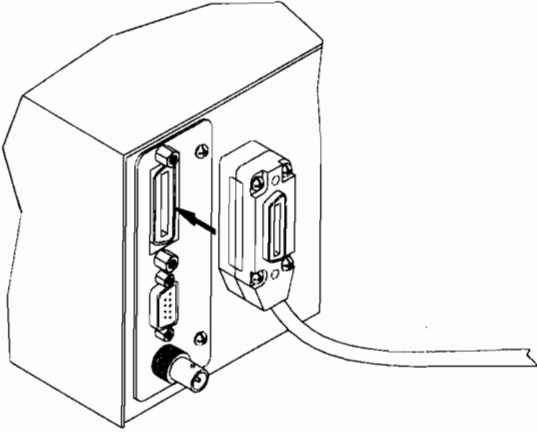

Figure 2-3 GPIB

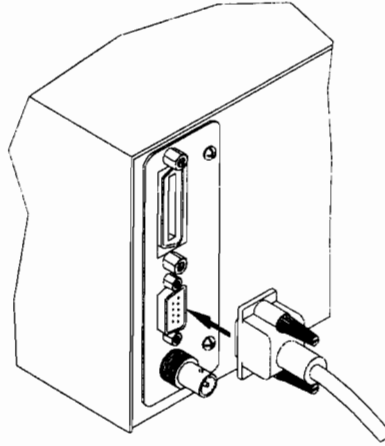

Figure 2-4 RS-232C

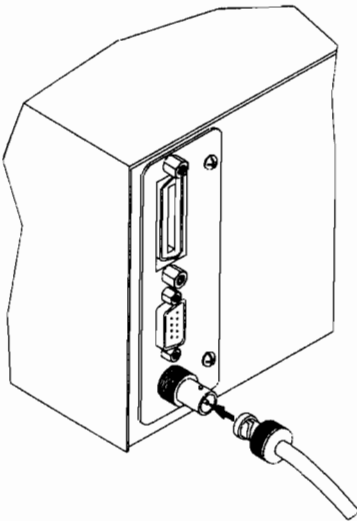

Figure 2-5 APG

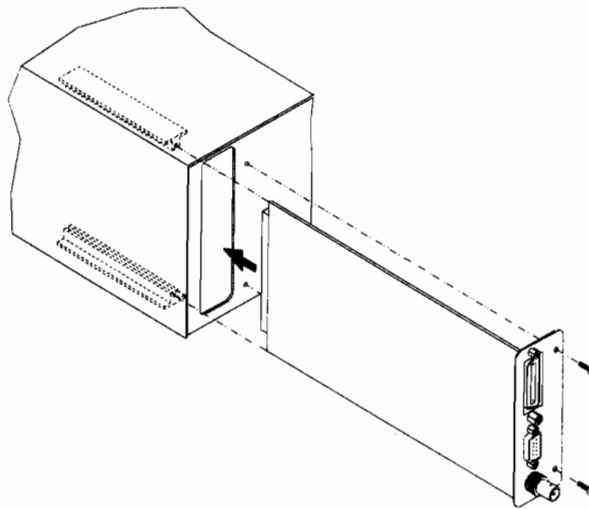

Figure 2-6 OPTION BOARD

3. Local Operation

3.1 Introduction

The Chroma 6408/6404 AC source may be configured to operate in either local or remote operational mode. Remote mode operation, using a remote GPIB controller, is described in the Sec. 6. This section describes the operation of the 6408/6404 using the front panel keypad for data entry and test execution when in local mode operation.

3.2 Set up

Configuration setup for 6408/6404 AC Source includes GPIB address, RS-232C baud rate, parity, OVP setting, enabling key stroke sound, and system test. The user must initiate configuration setup for the first time operation, and may modify them when application requirement is changed.

To enter into the setup, press the **SHIFT** key, the green LED turns on, then press the **0** key and hold it for 3 seconds, until the red 7-segment LEDs display the following :

SET UP	1
--------	---

Note 1 : If the user see the red indicator LED of “LOCK” turning on before or during pressing the **0** key, please release and press the **0** key again to switch it off. Then, press firmly the **0** key to wait for the setup screen.

Note 2 : Setup offers five available functions which can be selected using numeric keys **1** to **5** and confirmed by pressing the **ENTER** key. They are described in the following sections.

3.2.1 GPIB address

The 6408/6404 offers remote operation mode. For details, refer to “Remote Operation” to the 6408/6404 in Sec. 6. Prior to operating remotely, the user has to set GPIB address as following :

For example, set GPIB address as 25.

Action	Display
1. Enter configuration setup as stated in sec. 3.2, if required.	SEt Up 1
2. Press 1 , ENTER .	Gpib Addr 1
3. Press 2 , 5 , ENTER .	Gpib Addr 25
4. Press OUT/QUIT .	SEt Up 1

5. Select other setups by numeric keys, or press **OUT/QUIT** again to exit from setup.

Note 1 : Addressing space ranges from 0 to 30.

Note 2 : To confirm data entry, the **ENTER** key must be pressed within two seconds after the last numeric keypress, or the 6408/6404 disregards the programming value and the previous data is kept. This applies to all circumstances when the user enters numeric values.

3.2.2 RS-232C

The 6408/6404 offers the alternative remote operation using the RS-232C bus. Communication protocol is as following :

Example : Set baud rate = "19200", parity "ODD".

Action	Display
1. Enter configuration setup as stated in sec. 3.2, if required.	SEt Up 1
2. Press 2 , ENTER .	232C bAUd 96
3. Turn 0 to select "19200".	232C bAUd 192
4. Press ENTER .	232C PrtY nonE
5. Turn 0 to select "ODD".	232C PrtY odd
6. Press ENTER .	232C bAUd 192
7. Press OUT/QUIT .	SEt Up 2
8. Select other setups by numeric keys, or press OUT/QUIT again to exit from setup.	

Note 1 : Baud rate options are 2400, 4800, 9600, and 19200. They are displayed as 24/48/96/192 respectively.

Note 2 : Parity options are "NONE", "EVEN", and "ODD". They are displayed as "nonE", "EVEn", and "ODD".

3.2.3 OVP

The user is allowed to set limitation for output voltage, the 6408/6404 will then output power with the voltage never exceeding the user-defined upper limit to protect the loading devices.

Example : Set upper limit of output voltage to be 120V.

Action	Display
1. Enter configuration setup as stated in sec. 3.2, if required.	SEt UP 1
2. Press 3 , 0 , 0 , ENTER	OVP SEt 300.0
3. Press 1 , 2 , 0 , ENTER	OVP SEt 120.0
4. Press OUT/QUIT .	SEt Up 3
5. Select other setups by numeric keys, or press OUT/QUIT again to exit from setup.	

Note : Default limit is 300V.

3.2.4 Sound (ON/OFF)

The 6408/6404 offers the user selection of beep sounds while programming using keypad or turning . Default setting is "ON", to disable it, the user can do as below :

Action	Display
1. Enter configuration setup as stated in sec. 3.2, if required.	SEt UP 1
2. Press 4 , ENTER .	bEEP on
3. Turn  to change the option to be "OFF" and press ENTER .	bEEP oFF
4. Press OUT/QUIT .	SEt Up 4
5. Select other setups by numeric keys, or press OUT/QUIT again to exit from setup.	

3.2.5 System test

The user is allowed to check if the output power is within spec to the setting value. To enable the test, follow the procedures described below :

Action	Display
1. Enter configuration setup as stated in sec. 3.2, if required.	SEt Up 1
2. Press 5 , and ENTER .	SYS tEst no
3. Turn  to change the option to be "YES" and press ENTER .	SYS tEst YES

4. Press **OUT/QUIT**.

SEt Up 5

5. Select other setups by numeric keys, or press **OUT/QUIT** again to exit from setup.

Note 1 : Disconnect any output load when doing the system test.

Note 2 : In step 3, the 6408/6404 performs system test after pressing **ENTER**. Upon completion of 6408/6404 displays test result showing "PASS" or "FAIL". In case of failure, please contact your support for support.

3.3 Output Setting and Execution

After the 6408/6404 AC source passes power-on self-test or when the user completes the configuration setup, the 6408/6404 shows on the 7-segment LEDs the following values :

0.0	60.0	0.00
-----	------	------

which indicates that the present output settings for Vrms is 0 Volt, the output Freq is 60 Hz, and any of the measured values (including I/P/PF/CF) is 0. Before programming for the outputs V and F, setting limitation and output full range is to be done in advance. They are introduced in the next sections.

3.3.1 I limit

The output current limit is to guarantee the output current won't exceed the pre-defined value to protect loading devices from being damaged by the output peak current. The programmable range of peak current is from 0 to 20 in step of 0.08 A for 6408, and from 0 to 10 in step of 0.04 A for 6404. Operational example defining I limit = 8 A is interpreted as below.

Action	7-segment LED Display		
1. Enter shift mode by pressing SHIFT to turn on the "SHIFT" LED.	40.5	60.0	0.00
2. Press the I limit * key to turn on the "I LIMIT" LED.	40.5	15.0	0.00
3. Press 8 , ENTER .	40.5	8.00	0.00
4. Press SHIFT to turn off the "SHIFT" and "I LIMIT" LED, and turn on the "FREQ" LED.	40.5	60.0	0.00

Note 1 : In step 2, **I limit** key is the same as **V/F** key whose function is augmented due to shift being activated. Characters in blue print above the key indicates its new function as "I LIMIT".

Note 2 : In step 3, presses of data keypad for value of "I limit", or turning the rotary **0** to get to the value.

Note 3 : When "I limit" is set as value less than 0.8A (for 6408) or 0.4A (for 6404), the "I LIMIT" LED is blinking. The user should change to a value within instrument specification.

3.3.2 Range

The full range of output voltage is selectable to be 150V, 300V, or AUTO. For example, set range to be 300V.

Action	Indicator LED Display
1. Enter shift mode by pressing SHIFT to turn on the "SHIFT" LED.	Green "SHIFT" LED turns on.
2. Press the RANGE key several times until the "300V" LED turns on.	Green "300V" LED turns on.
3. Press SHIFT to quit from the "SHIFT" mode.	Green "SHIFT" LED turns off.

3.3.3 Output V and F

For example : To set V=135.5 volt, F=82 Hz

Action	7-segment LED Display
1. If the "EXT PROG" LED is "ON", please turn it off by pressing SHIFT to turn on the "SHIFT" LED, then pressing EXT PROG .	40.5 60.0 0.00
2. If the "SHIFT" LED is "ON", quit from shift mode by pressing SHIFT to turn it off.	40.5 60.0 0.00
3. Press V/F to switch on "VOLT" LED and switch off "FREQ" LED.	40.5 60.0 0.00
4. Press 1 3 5 . 5 ENTER or turn ⏏ to the desired voltage value.	135.5 60.0 0.00
5. Press V/F to switch off "VOLT" LED and switch on "FREQ" LED.	135.5 60.0 0.00
6. Press 8 2 ENTER or turn ⏏ to the desired frequency value.	135.5 82.0 0.00
7. When completes, press OUT/QUIT to activate output power to the loading devices.	

3.4 Save and Recall

The 6408/6404 AC Source offers nine memory channels for the user to save a set of frequently used V, F, and full range, and to recall them for later use.

To save settings to the memory channel 5 :

Action	7-segment LED Display		
1. Enter into the "SHIFT" mode by pressing SHIFT to turn on the "SHIFT" LED.	135.5	82.0	0.00
2. Press F5 and hold for 3 seconds until hearing a beep sound signaling completion, and the LED displays memory channel number F5.	135.5	82.0	F5

To recall from memory channel 4 :

Action	7-segment LED Display		
1. Enter into the "SHIFT" mode by pressing SHIFT to turn on the "SHIFT" LED.	250.0	70.0	0.00
2. Press F4 , and release immediately without holding. Contents of pre-stored setting values are shown on the LED.	40.5	60.0	0.00
3. If these are not the desired setting values, repeat step 2 to step 3 for other memory channels until the right one is found.	55.0	60.0	0.00
4. Confirm by pressing ENTER .	135.5	82.0	0.00

3.5 Data Lock

After completion of setting values for outputs, the front panel keypad can be locked to avoid incident changes.

To lock setting output data, press **SHIFT** to light up the "SHIFT" LED. Then, press **LOCK**, the same as the key, to turn on the "LOCK" LED.

To unlock, press **SHIFT** to light up the "SHIFT" LED. Then, press **LOCK**, the same as the **0** key, to turn the "LOCK" LED.

3.6 Ext Prog

The 6408/6404 AC source allows the user to use an external DC voltage level as a linear control reference for output Vrms. The relationship of Vout and the Vref is listed as following :

$$V_{out} = V_{ref} \div 10V \times V_{fs}$$

Vout : The Vrms output of the 6408/6404

Vref : DC level of the external control voltage

Vfs : The current setting of full scale (full range) of output Vrms.

When the “EXT PROG” is active, the user is not allowed to program the value for Vout. The user can still program the value for output F. To enable this function, the user must connect the external device of controlled DC to the “APG” port of 6408/6404 on the rear panel as illustrated in the sec. 2.6.

To enable it, press the **SHIFT** to light up the “SHIFT” LED. Then, press **EXT PROG** , the same as the **OUT/QUIT** key, to turn on the green “EXT PROG” LED. And quit “SHIFT” mode by pressing the **SHIFT** to turn off the “SHIFT” LED.

The user may press the numeric keypad and **ENTER** or turn  for changing output frequency to the desired.

To disable it, press the **SHIFT** to light up the “SHIFT” LED. Then, press **EXT PROG**, the same as the **OUT/QUIT** key, to turn off the green “EXT PROG” LED.

3.7 Measurement

The 6408/6404 can measure actual performance V, F, I, P, PF, and CF of the load connected to it without using extra measurement instrument when the 6408/6404 AC source outputs power to the load. During operation, V and F measurement data are always shown on the LEDs at the left and the middle zone. The right zone displays one of the I, P, PF, and CF measurement according to the user’s choice.

The sample LED shows the measurement V = 132.2V, F = 75Hz as below :

132.2	75.0	0.03
-------	------	------

The next section describes how to select one of the measurement I, P, PF, CF for automatic read-back.

3.7.1 Select Measurement Items

1. If output is not activated, press the **OUT/QUIT** to turn on the “OUT” LED.
2. When operating in “SHIFT” mode, quit “SHIFT” mode by pressing the **SHIFT** to switch off the green “SHIFT” LED.
3. Press **I/P/PF/CF** to light up one of the four LEDs among I, P, PF, and CF.

It keeps changing one by one among these four options if the user presses this key again and again. Hence, the right displayed value reacts to the corresponding measurement parameters after each keypress as the following sequence.

I ⇒ P ⇒ PF ⇒ CF ⇒ (go back I)

3.7.2 Measurement Functions

The 6408/6404 offers the following 6 measurement functions.

Function	Description
V	Voltage measurement readings in volts. (True R.M.S. measurement)
F	Frequency measurement readings in Hertz.
I	Current measurement readings in Amperes. (True R.M.S. measurement)
P	True power measurement in Watts.
CF	Crest factor, calculation formula = I_{peak}/I_{rms} .
PF	Power factor, calculation formula = $\text{true power}/(V_{rms} \times I_{rms})$

3.8 Local

During remote operation, the 6408/6404 is controlled by a remote GPIB or RS-232C controller, and the green indicator LED of “RMT” remains turned on. To return from remote to front panel operation, press the **Local** key in “SHIFT” mode. When not in “SHIFT” mode, the user needs to press **SHIFT** key to return to normal mode before pressing **Local** key.

3.9 Protection

During operation, if the 6408/6404 senses under voltage (UVP), over load (OLP), shortage (SHT), over power (OPP), over temperature (OTP), or fan failure (FAN), the red indicator LED of "PROTECTION" turns on and the protection circuit is enabled to shut down the outputs. Before restart the output, the user must eliminate the condition that causes the 6408/6404 to react to "PROTECTION". For detail description and recovery suggestion, please refer to "Troubleshooting" in sec. 5.3.

4. Theory of Operation

4.1 General

The 6408/6404 AC power source consists of 8 main boards and other discrete components. Each has its specific function that will be described in the sections followed.

4.2 Overall System Description

Figure 4-1. shows the overall system blocks. Main power flows through the A/D, D/A power stage converter. The A/D power stage is designated as **I board** and generates DC voltage from the line input. The DC voltage of the A/D output is applied to the input of the next power stage.

The **P board** of D/A stage take power from the A/D output, the fan speed control circuit is also on **P board**.

The isolated output transformer takes power from D/A output and transfer it to two sets at secondary, connected in parallel or serial at **O board** to obtain more current or higher voltage.

A board is identified as **CPU**. The 64180 CPU is used here to communicate with DSP at **B board** for programming variable output voltages and frequencies, to monitor or control the signal and interrupts, and to perform remote control through the GPIB or RS-232C interface on the optional board.

B board is identified as the sine wave generator, measurement unit, and D/A power stage controllers. It generates sine waves acting as the reference input of the D/A stage. All measurement functions are done here.

The seven-segment LEDs and keyboard are identified as **D board** and **K board** respectively, which makes the interfaces between the user and the instrument. Fan is used to remove extra heat from interior of the 6408/6404 AC Source.

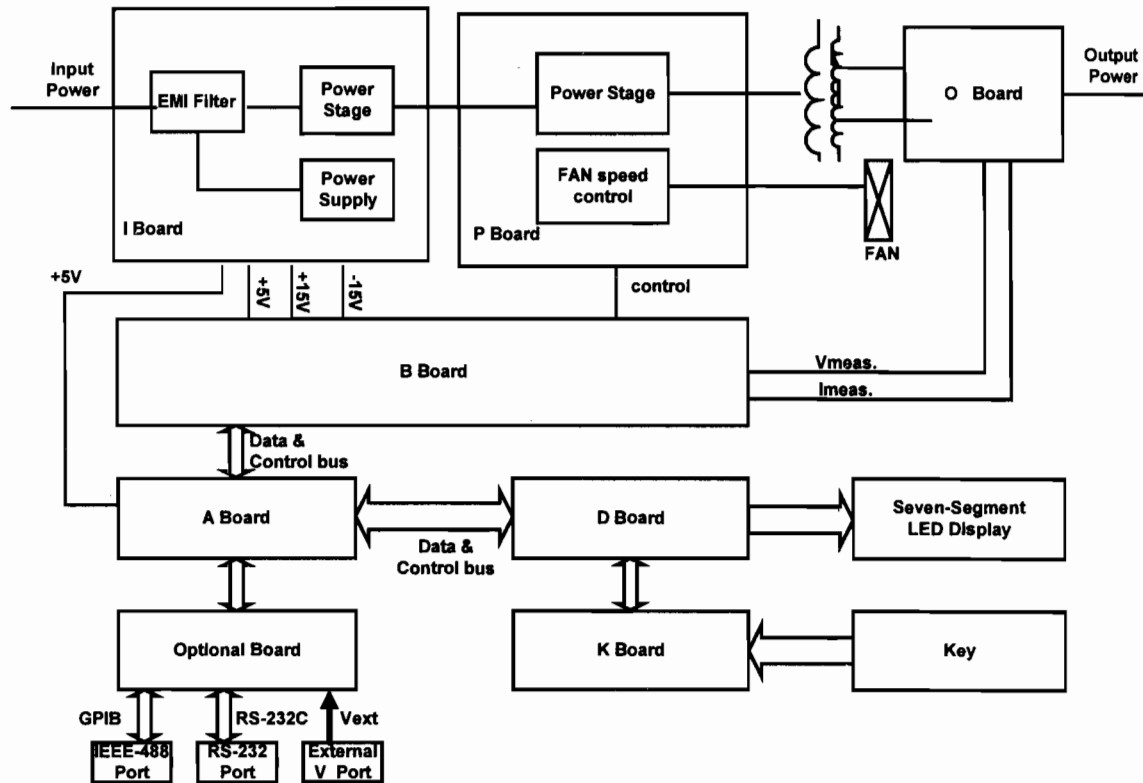

Figure 4-1 System Block Diagram

4.3 AC/DC Power Stage Converter

This assembly is identified as **I board**. It generates the high voltage V_{dc} supply. This power stage also includes power supply circuits that generate the DC voltage identified as +15V, -15V, +5V. Power factor correction technology for 6408 is used to achieve a power factor of 0.98 or more.

4.4 DC/AC Inverter

This assembly comprises of control part at **B board**, **P board**, output transformer, and **O board**. It generates an AC output sine wave.

Advanced PWM technology is applied to this system to obtain more stability. Maximum peak current is clamped to protect output power MOSFET. Overload protection (OLP), which contains output protection against short circuit, is also implemented here.

P board is made up of the full bridge of MOSFET power components. The PWM control signal from controller is applied to the full bridge to amplify the output. The low pass filter can reject the switching frequency component.

O board consists of the range relays and output relays. Range relays connect the two sets of the secondary of output transformer together in parallel or serial.

4.5 CPU

The CPU, **A board**, uses a 64180 CPU to control the circuit. A microprocessor circuit accepts commands from the GPIB or RS-232C controller, or from the front panel keyboard. It sends digital programming information to DSP controller to set the output parameters of the power source. Data from measurement circuits are accepted and reported to the display and GPIB. Setup parameters and one key operation data are stored in EEPROM.

4.6 Measurement and Sine wave Generator (B Board)

Measurement circuits on **B board** monitor voltage, current, power etc. Voltage from the output is scaled, and sent to the DSP processor by the analog-to-digital converter.

Current sensed by the current shunt is scaled, and sent to the DSP processor by the analog-to-digital converter.

The true-RMS measurement is made by software of the DSP processor, and so is the power.

The digital-to-analog converter on **B board** sets the DC voltages that are used for the programmable voltage function. Low pass filter is applied to smooth the reference input signal.

4.7 Keyboard and Display

The keyboard is designated as **K board** which is connected through a short flat ribbon cable. It holds 16 key switches and 2 LED indicators. The display is also connected from **B board** through a short flat ribbon cable. It comprises of three 4-digit seven-segment LEDs. Programming of V, F can also be done by rotary knob on the front panel.

4.8 GPIB/RS-232C/External reference

The remote control is done through the GPIB or RS-232C interface on the optional board which is connected to **A board** through the DIN connector. External reference is for the user to use DC reference to control the amplitude of output AC voltage.

5. Self-test and Troubleshooting

5.1 General

This section describes the suggested self-test and troubleshooting procedures when AC source does not function normally. If the problem cannot be solved using the information given here, consult the distributor from whom you purchased the unit.

5.2 Self-test Routine

The 6408/6404 AC Power source has a built-in test/adjust program for the user to test/adjust the unit. Do not adjust any component without prior approval. Consult the distributor for information on adjustments.

**** WARNING ****

Disconnect any load from output when using the test/adjust program. Any load from the instrument may cause test failure.

5.3 Troubleshooting

The following table lists the operating problems and suggests corrective actions :

Problem	Reason	Solution
Poor Voltage Accuracy	HIGH or LOW line of output voltage maybe shorted to the case ground.	Isolate output line from case.
Poor measurement of V, I, P	Aging of components results in deviation of characteristics. Periodical calibration or adjustment is required.	Refer to service manual for internal reference of voltage adjustment.
Over Temperature Protection (OTP)	Ambient temperature is too high	Operate the unit between 0 and 40 °C.
Over Load Protection (OLP)	The output is overloaded.	Remove the overload.
Short Circuit (SHT)	The output is shorted.	Remove the short.
Over Power protection (OPP)	The output power is over specification.	Remove the over power or lower down output voltage.
Cannot Control AC Source System by GPIB	<ol style="list-style-type: none"> 1. The AC source unit address is incorrect. 2. GPIB cable is loosen at AC source rear panel. 	<ol style="list-style-type: none"> 1. Update address. 2. Check connection, tighten the screws.
Distorted Output	<ol style="list-style-type: none"> 1. The AC source output voltage is too low. 2. The rectified load is too large at high frequency. 	<ol style="list-style-type: none"> 1. Program higher output voltage. 2. Reduce the load or lower the output frequency.
Fan Inhibited Protection (FAN)	Fan or ventilation holes are blocked.	Remove obstruction.
Under Voltage Protection (UVP)	The AC source line input voltage is too low.	Measure input voltage, and raise it if it is under the specification.

6. Remote Operation

6.1 General Information

The AC source can be remotely controlled through the GPIB or the RS-232C interface. It is recommended that the timeout duration is not less than 1 second. For RS-232C interface, only the TXD, RXD, RTS, CTS signals is used for data transfer. The CD, DTR, DSR signals are shorted in the AC source. Interconnection between the IBM PC/AT and the AC source is illustrated below.

IBM PC/AT	AC SOURCE	Pin Definition
PIN 1	1	CD*
2	2	RXD
3	3	TXD
4	4	DTR*
5	5	SG
6	6	DSR*
7	7	RTS
8	8	CTS
9	9	RI*

* These signals may be disconnected if not required.

6.2 GPIB Capability of the AC Source

GPIB Capability	Description	Interface Functions
Talker/Listener	Commands and response messages can be sent and received over the GPIB Bus. Status information can be read using a serial poll.	AH1, SH1, T6, L4
Service Request	The ac source sets the SRQ line true if there is an enabled service request condition.	SR1
Remote/Local	The ac source powers up in local state. In local state, the front panel are operative and the ac source may respond to commands from GPIB. In remote state, all front panel keys except local key are disabled. Pressing local key returns the ac source to local state. Local key can be disabled using local lockout so that only the controller or the power switch can return the ac source to local mode.	RL1
Device Clear	The ac source responds to the Device Clear (DCL) and Selected Device Clear (SDC) interface commands. These cause the ac source to clear any activity that would prevent it from receiving and executing a new command. DCL and SDC do not change any programmed settings.	DCL, SDC

6.3 Introduction to Programming

All command and response messages are transferred in the form of the ASCII codes. The entire response messages should be read before a new command is sent, otherwise the rest response messages will be lost and a query interrupted error occur.

6.3.1 Conventions

- <> Items within angle brackets are parameter abbreviations.
- | separate alternative parameters. For example, ON | OFF indicates that either "ON" or "OFF" can be used as a parameter.
- [] Items within square brackets are optional. For example, OUTP[:STATe] means that :STATe may be omitted.

6.3.2 Numerical Data Formats

Formats :

The 6408/6404 AC Source accepts numeric data of the following formats :

Symbol	Description	Example
NR1	Digits with no decimal point. The decimal point is assumed to be to the right of the least-significant digit.	123, 0123
NR2	Digits with a decimal point.	12.3, .123
NR3	Digit with a decimal point and an exponent.	1.23E+2, 12.3E-1
NRf	Flexible decimal form that includes NR1, NR2, NR3	12, 12.3, 1.23E2
NRf+	Expanded decimal form that includes NRf, MINimum and MAXimum. MINimum and MAXimum are the minimum and maximum limit values for the parameter.	12, 12.3, 1.23E2 MIN, MAXimum

Suffixes :

Numeric data may be followed by an optional suffix including a multiplier and/or unit . If the suffix is omitted, default units are used.

The default units of Frequency, Voltage, and Current are Hz, Volt, and Ampere respectively. The valid suffixes (units and multipliers) are as follows :

Units

Class	Preferred Suffix	Allowed Suffix	Referenced Unit
Frequency	Hz		Hertz
		MHz	Megahertz
Voltage	V		Volt
Current	A		Ampere

Common multipliers

Multiplier	Definition
K	1E3
M	1E-3

6.3.3 Boolean Data Format

The boolean parameter <Boolean> takes the form ON|OFF|<NRf>. Boolean parameter has a value of “0” or “1”, and is unitless. Any input value of <NRf> is rounded to an integer and the non-zero result is interpreted as “1”. The values “ON” and “OFF” are also acceptable on the input commands for increasing readability. “ON” represents “1”, and “OFF” corresponds to “0”.

Queries will return “1” or “0”, not “ON” or “OFF”.

6.3.4 Character Data Format

The character strings returned by query command may take either of the following forms:

- <CRD> Character Response Data: character string with maximum length of 12.
- <SRD> String Response Data: character string enclosed in double quotes.

6.3.5 Basic DefinitionCommand Tree Table:

The ac source commands are based on a hierarchical structure, also known as a tree system. To obtain a particular command, the full path to it must be specified. This path is represented in the table by placing the highest node in the hierarchy in the left-most position. Lower nodes in the hierarchy are indented on position to the right, below the parent node.

Program Headers:

Program headers are keywords that identify the command. The program headers follow the syntax described in section 7.6 of IEEE 488.2. The ac source accepts both upper and lowercase characters without distinguishing between the cases. Program headers consist of two distinct types, common command headers and instrument-control headers.

Common Command and Query Headers:

The common command and query program header syntax is specified in IEEE 488.2 for use with the IEEE 488.2-defined common commands and queries. The commands with a leading "*" are common commands.

Instrument-Control Headers:

Instrument-control headers are used for all other instrument commands. Each instrument-control header has both a long and a short forms. The ac source accepts only the exact short and the exact long forms. Note that elsewhere in this section a special notation is employed to differentiate the short form header from the long form header of the same header. The long form of the header is shown, with the short form portion shown in uppercase characters, and the rest of the header is shown in lowercase characters.

Program Header Separator:

Data must be separated from program header by at least one space.

Program Message:

Represents a sequence of zero or more program message unit elements separated by program message unit separator elements.

Program Message Unit:

Represents a single command, programming data, or query.

Examples: VOLT?, OUTPut ON.

Program Message Unit Separator (;):

Separates the program message unit elements from one another in a program message.

Example: VOLT 110 ; FREQ 120 <PMT>

Program Message Terminator (<PMT>):

A program message terminator terminates a program message. Three permitted terminators are:

- (1) <END>: end or identify(EOI).
- (2) <NL>: new line, which is a single ASCII-encoded byte 0A (10 decimal).
- (3) <NL><END>: new line with EOI.

Note : The response message is terminated by <NL> <END> for GPIB, <NL> for RS-232C.

6.4 Traversal of the Command Tree

Multiple program message unit elements may be sent in a program message. The first command is always referenced to the root node. Subsequent commands are referenced to the same tree level as the previous command in a program message .

Note that the common command and query headers don't affect the header path.

A column preceding a program message unit alters the header path to the root level.

For example:

- (1) VOLT:RANG 150;LIM 140 <PMT> will set the output voltage to 150V range and the maximum rms output voltage to 140V.

- (2) CURR:PEAK 8;VOLT 110 <PMT> will set the output peak current to 8A and generate a command error because VOLTage is not a node at the current level.
- (3) CURR:PEAK 8;;VOLT 110 <PMT> will set the output peak current to 8A and the voltage to 110V.
- (4) VOLT:RANG 300;*ESE 32;LIM 250 <PMT> will set the output voltage to 300V range and the Standard Event Status Enable Register to 32 and the maximum rms output voltage to 250 Volt.

Optional nodes in the tree will not alter the header path. For example:

- (1) FREQ 120;VOLT 110 <PMT> will set the frequency to 120Hz and voltage to 110 Volt. Note that FREQ 120 doesn't change the header path to FREQ:CW.
- (2) VOLT:LEV 110;RANG 150 <PMT> will set the rms output voltage to 110 Volt and set the output voltage range to 150V range.

6.5 Execution Order

The AC Source executes program messages in the order received. Program message units are executed in order of reception except coupled commands. The execution of coupled commands are deferred until program message terminator is received. A coupled command sets parameters which are affected by the settings of the other commands. Problems can arise because the prior state of the AC Source can affect the response to the programming of a coupled parameter.

For example, assuming the current output voltage range is 150V, and a new state is desired with output voltage range 300V and amplitude 220 Volts. If the commands

VOLTage 220<PMT>

VOLTage:RANGe 300<PMT>

are sent, a **data out of range** error will occur. Such kind of error can be avoided by reversing the order, or sending the commands in one program message. For the above case, the program message

VOLTage 220;VOLTage:RANGe 300<PMT>

can be sent without error.

The following commands are coupled: VOLTage, VOLTage:RANGe, VOLTage:RANGe:AUTO, VOLTage:LIMit, VOLT:EPRogram.

6.6The AC Source Commands

6.6.1 Command Tree Table

MEASure|FETCh

[:SCALar]

:CURRent

:AC?

Returns the output ac rms current

:CREStfactor?

Returns the output current crest factor

:FREQUency?

Returns the output frequency

:POWer	
:AC	
[:REAL]?	Returns the output real power
:PFACtor?	Returns the output power factor
:VOLTagE	
:AC?	Returns the output ac rms voltage
OUTPut	
[:STATe] <Boolean>	Enables/Disables the output
:PROTection	
:CLEar	Causes the latched protection to be cleared
[SOURce:]	
CURRent	
:PEAK	
[:IMMediate] <NRf+>	Sets the output peak current limit
FREQuency	
[:CW :FIXed] <NRf+>	Sets the output frequency
VOLTagE	
[:LEVel]	
[:IMMediate]	
[:AMPLitude] <NRf+>	Sets the ac rms output voltage amplitude
:EPROgram	
[:STATe] <Boolean>	Enables/Disables the external program mode
:LIMit	
[:AMPLitude] <NRf+>	Sets the limit on output ac rms voltage amplitude
:RANGe 150 300	Sets the output voltage range
:AUTO <Boolean>	Enables/Disables AUTO output voltage range mode
STATus	
PRESet and Operation status	Presets the PTR, NTR and Enable Registers of Questionable
:OPERation	
[:EVENT]?	Returns the content of the Event Register
:CONDition?	Returns the content of the Condition Register

:ENABle <NRf>	Sets the Enable Register
:QUESTionable	
[:EVENT]?	Returns the content of the Event Register
:CONDition?	Returns the content of the Condition Register
:ENABle <NRf>	Sets the Enable Register
:NTRansition <NRf>	Sets the negative transition filter
:PTRansition <NRf>	Sets the positive transition filter
SYSTEM	
:ERRor?	Returns the error message
:LOCal	Goes to local mode (RS-232C only)
:REMote	Goes to remote mode (RS-232C only)
:RWLock	Goes to remote with lockout mode (RS-232C only)
*CLS	Clears status
*ESE <NRf>	Sets the Standard Event Status Enable Register
*ESR?	Returns the Standard Event Status Register
*IDN?	Returns the device identification
*OPC	Generates operation complete message when operation completes
*OPC?	Returns "1" when operation completes
*RST	Reset
*SRE <NRf>	Sets Service Request Enable Register
*STB?	Returns Status Byte Register
*TST?	Performs self-test, then returns result
*WAI	Wait-to-continue

6.6.2 Command Dictionary

MEASure:CURRent:AC?

FETCh:CURRent:AC?

Description: These queries return the output ac rms current. It is noted that there are two kinds of commands to get measurement data. MEASure commands make a new measurement and return measurement

data. FETCh commands return measured data taken by previous MEASure command. Note that once a new measurement is made, all new measurement data (V, F, I, P, PF, CF) may be returned by FETCh commands.

Query Syntax: MEASure[:SCALar]:CURRent:AC?

FETCh[:SCALar]:CURRent:AC?

Parameters: None

Return Parameters: <NR2>

Query Example: MEAS:CURR:AC? returns the output ac rms current.

MEASure:CURRent:CREStfactor?

FETCh:CURRent:CREStfactor?

Description: These queries return the output current crest factor.

Query Syntax: MEASure[:SCALar]:CURRent:CREStfactor?

FETCh[:SCALar]:CURRent:CREStfactor?

Parameters: None

Return Parameters: <NR2>

Query Example: MEAS:CURR:CRES? returns the output current crest factor.

MEASure:FREQuency?

FETCh:FREQuency?

Description: These queries return the output frequency.

Query Syntax: MEASure[:SCALar]:FREQuency?

FETCh[:SCALar]:FREQuency?

Parameters: None

Return Parameters: <NR2>

Query Example: MEAS:FREQ? returns the output frequency.

MEASure:POWer:AC?

FETCh:POWer:AC?

Description: These queries return the output real power.

Query Syntax: MEASure[:SCALar]:POWer:AC[:REAL]?

FETCh[:SCALar]:POWer:AC[:REAL]?

Parameters: None

Return Parameters: <NR2>

Query Example: MEAS:POW:AC? returns the output real power.

MEASure:POWer:AC:PFACtor?

FETCh:POWer:AC:PFACtor?

Description: These queries return the output power factor.

Query Syntax: MEASure[:SCALar]:POWer:AC:PFACtor?

FETCh[:SCALar]:POWer:AC:PFACtor?

Parameters: None

Return Parameters: <NR2>

Query Example: MEAS:POW:AC:PFAC? returns the output power factor.

MEASure:VOLTag:e:AC?

FETCh:VOLTag:e:AC?

Description: These queries return the output ac rms voltage.

Query Syntax: MEASure[:SCALar]:VOLTag:e:AC?

FETCh[:SCALar]:VOLTag:e:AC?

Parameters: None

Return Parameters: <NR2>

Query Example: MEAS:VOLT:AC? returns the output ac rms voltage.

OUTPut

Description: This command enables or disables the ac source output.

Syntax: OUTPut[:STATe] <Boolean>

Parameters: 0 | 1 | OFF | ON

*RST Value: OFF

Example: OUTP ON enables output

OUTP 0 disables output

Query Syntax: OUTPut[:STATe]?

Return Parameters: 0 | 1

Query Example: `OUTP?` returns the output enable condition.

OUTPut:PROTection:CLEAr

Description: This command clears the latch that disables the output when a short, over load, over power, over temperature, fan fail, under voltage condition is detected. All conditions that cause the protection should be removed before the latch can be cleared. The output then remains disable until another `OUTP ON` command is received.

Syntax: `OUTPut:PROTection:CLEAr`

Parameters: None

Example: `OUTP:PROT:CLE` clears the latched protection.

CURRent:PEAK

Description: This command sets the output peak current.

Syntax: `[SOURce:]CURRent:PEAK[:IMMediate] <NRf+>`

Parameters: 0 to 10 for 6404, 0 to 20 for 6408

*RST Value: 10 for 6404, 20 for 6408

Example: `CURR:PEAK 15` sets the output peak current to 15A.

`CURR:PEAK MAX` sets the output peak current to maximum value.

Query Syntax: `[SOURce:]CURRent:PEAK[:IMMediate]?`

Return Parameters: `<NR2>`

Query Example: `CURR:PEAK?` returns the setting value of output peak current.

FREQuency

Description: This command sets the output frequency.

Syntax: `[SOURce:]FREQuency[:CW|:FIXed] <NRf+>`

Parameters: 45 to 500

*RST Value: 60 Hz

Example: `FREQ 120` sets the output frequency to 120Hz.

`FREQ MAX` sets the output frequency to 500Hz.

Query Syntax: `[SOURce:]FREQuency[:CW|:FIXed]?`

Return Parameters: `<NR2>`

Query Example: `FREQ?` returns the setting value of output frequency .

VOLTage

Description: This command sets the ac rms output voltage amplitude. The maximum value is dependent on voltage range and voltage limit setting.

Syntax: [SOURce:]VOLTage[:LEVel][:IMMediate][:AMPLitude] <NRf+>

Parameters: 0 to 300

*RST Value: 0

Example: VOLT 110 sets the ac rms output voltage to 110V.

Query Syntax: [SOURce:]VOLTage[:LEVel][:IMMediate][:AMPLitude]?

Return Parameters: <NR2>

Query Example: VOLT? returns the setting value of output voltage.

VOLTage:EPROgram

Description: This command enables or disables the external program mode. During external program mode, the ac rms output voltage is controlled by an external reference dc voltage.

Syntax: [SOURce:]VOLTage:EPROgram[:STATe] <Boolean>

Parameters: 0 | 1 | OFF | ON

*RST Value: OFF

Example: VOLT:EPR ON enables external program mode

Query Syntax: [SOURce:]VOLTage:EPROgram[:STATe]?

Return Parameters: 0 | 1

Query Example: VOLT:EPR? returns the state of external program mode

VOLTage:LIMit

Description: This command sets the maximum bounds on the ac rms output voltage value. Setting a larger output voltage value will cause the output to be clamped to the LIMit value.

Syntax: [SOURce:]VOLTage:LIMit[:AMPLitude] <NRf+>

Parameters: 0 to 300

*RST Value: 300

Example: VOLT:LIM 130 sets the ac rms output voltage limit to 130V.

Query Syntax: [SOURce:]VOLTage:LIMit[:AMPLitude]?

Return Parameters: <NR2>

Query Example: VOLT:LIM? returns the setting value of output voltage limit.

VOLTage:RANGe

Description: This command sets the output voltage range of the ac source. Two ranges are available: 150V and 300V range. When setting output voltage to 150V range, if the setting of output voltage is greater than 150V, then the output voltage setting will be clamped to 150V. Setting an output voltage range will disable the AUTO range mode.

Syntax: [SOURce:]VOLTage:RANGe <NRf+>

Parameters: 150 | 300

*RST Value: 150

Example: VOLT:RANG 300 sets the output voltage to 300V range.

Query Syntax: [SOURce:]VOLTage:RANGe?

Return Parameters: <NR1>

Query Example: VOLT:RANG? returns the current output range.

VOLTage:RANGe:AUTO

Description: This command enables or disables the AUTO output voltage range mode. In AUTO mode, setting an output voltage greater than 150 volt will switch the output range to 300V range, otherwise the 150V range is selected.

Syntax: [SOURce:]VOLTage:RANGe:AUTO <Boolean>

Parameters: 0 | 1 | OFF | ON

*RST Value: OFF

Example: VOLT:RANG:AUTO ON enables the AUTO output voltage range mode.

Query Syntax: [SOURce:]VOLTage:RANGe:AUTO?

Return Parameters: 0 | 1

Query Example: VOLT:RANG:AUTO? returns the condition of AUTO range mode.

STATus:PRESet

Description: This command sets the PTR, NTR and Enable Registers of Questionable and Operation status as follow: all defined bits of PTR Registers to 1, all bits of NTR and Enable Registers to 0.

Syntax: STATus:PRESet

Parameters: None

Example: STAT:PRES preset the PTR, NTR and Enable Registers of Questionable status.

STATus:OPERation?

Description: This query returns the content of the Operation Event Register. The Operation Event Register is

cleared when read or by the *CLS common command.

Query Syntax: STATus:OPERation[:EVENT]?

Parameters: None

Return Parameters: <NR1>

STATus:OPERation:CONDition?

Description: Returns the content of Operation Condition Register. The Condition Register reflects the TRUE or FALSE state of Operation status.

Query Syntax: STATus:OPERation:CONDition?

Parameters: None

Return Parameters: <NR1>

STATus:OPERation:ENABLE

Description: This command sets the enable mask which allows true conditions in the Operation Event Register to be reported in the Operation Status (OPER) Summary-Message of the Status Byte Register.

Syntax: STATus:OPERation:ENABLE <NRf>

Parameters: 0 to 32767

Query Syntax: STATus:OPERation:ENABLE?

Return Parameters: <NR1>

Bit configuration of Questionable Status Register

Bit Position	15-12	11	10	9	8	7-4	3	2	1	0
Condition	---	Ipk	OPP	FAN	OLP	---	OTP	---	SHT	UVP
Bit Weight		2048	1024	512	256		8		2	1

Remark: Ipk : Peak current limit protection OPP : Over power protection
 FAN : Fan failure OLP : Over load protection
 OTP : Over temperature protection SHT : Short circuit protection
 UVP : Under voltage protection

STATus:QUESTIONable?

Description: This query returns the content of the Questionable Event Register. The Questionable Event Register latches events that are passed by Questionable PTR and/or NTR filter. It is cleared when read or by the *CLS common command.

Query Syntax: STATus:QUESTIONable[:EVENT]?

Parameters: None

Return Parameters: <NR1>

Query Example: STAT:QUES? returns and clears the Questionable Event Register.

STATus:QUEStionable:CONDition?

Description: Returns the content of the Questionable Condition Register. The Questionable Condition Register reflects the TRUE or FALSE state of Questionable status.

Query Syntax: STATus:QUEStionable:CONDition?

Parameters: None

Return Parameters: <NR1>

Query Example: STAT:QUES:COND? returns the Questionable Condition Register.

STATus:QUEStionable:ENABle

Description: This command sets the enable mask which allows true conditions in the Questionable Event Register to be reported in the Questionable Status (QUES) Summary-Message of the Status Byte Register.

Syntax: STATus:QUEStionable:ENABle <NRf>

Parameters: 0 to 32767

Example: STAT:QUES:ENAB 8 enables OTP event to be reported in the Status Byte Register.

Query Syntax: STATus:QUEStionable:ENABle?

Return Parameters: <NR1>

Query Example: STAT:QUES:ENAB? returns the content of Questionable Enable Register.

STATus:QUEStionable:NTRansition

STATus:QUEStionable:PTRansition

Description: These command sets the content of the Questionable NTR (negative transition 1-to-0) and PTR (positive transition 0-to-1) Registers. These Registers determine which type of transition in the Condition Register may set the corresponding bit in the Questionable Event Register.

Syntax: STATus:QUEStionable:NTRansition <NRf>

STATus:QUEStionable:PTRansition <NRf>

Parameters: 0 to 32767

Example: STAT:QUES:NTR 8 enables OTP event bit to be set as 1-to-0.

STAT:QUES:PTR 2 enables SHT event bit to be set as 0-to-1.

Query Syntax: STATus:QUEStionable:NTRansition?

STATus:QUEStionable:PTRansition?

Return Parameters: <NR1>

Query Example: STAT:QUES:PTR? returns the content of Questionable PTR Register.

SYSTem:ERRor?

Description: This query returns the next error number followed by its corresponding error description string from the error queue. As errors are detected, they are placed in the queue. The queue is first in, first out. If the queue overflows, the last error in the queue is replaced with the error **-350,"Queue overflow"**. Reading an error from the head of the queue removes that error from the queue. When all errors have been read, further error queries will return **0, "No error"**.

Query Syntax: SYSTem:ERRor?

Parameters: None

Return Parameters: <NR1>, <SRD>

Query Example: SYSR:ERR? returns the next error number and description.

SYSTem:LOCal

Description: This command sets the ac source to local state, which enables the front panel controls. It can only be used with the RS-232C interface.

Syntax: SYSTem:LOCal

Parameters: None

Example: SYST:LOC sets the ac source to local state.

SYSTem:REMote

Description: Sets the ac source to remote state, which disables the front panel controls except the local key. Pressing the local key while in the remote state returns the ac source to the local state. This command can only be used with the RS-232C interface.

Syntax: SYSTem:REMote

Parameters: None

Example: SYST:REM sets the ac source to remote state.

SYSTem:RWLock

Description: Sets the ac source to remote-lockout state, which disables the front panel controls including the local key. This command can only be used with the RS-232C interface.

Syntax: SYSTem:RWLock

Parameters: None

Example: SYST:RWL sets the ac source to remote-lockout state.

***CLS, Clear Status Command**

Description: This command clears all Event Registers summarized in the Status Byte Register (Standard Event Status Register, Questionable Event Register), and clears the error queue. If the *CLS command immediately follows a program message terminator, the output queue and the MAV Summary-Message are also cleared.

Syntax: *CLS

Parameters: None

Bit configuration of Standard Event Status Register

Bit position	7	6	5	4	3	2	1	0
Condition	PON	---	CME	EXE	DDE	QYE	---	OPC
Bit Weight	128		32	16	8	4	2	1

Remark: PON : Power on

QYE : Query error

CME : Command error

EXE : Execution error

DDE : Device-dependent error

OPC : Operation complete

***ESE, Standard Event Status Enable Command**

Description: This command sets the enable mask which allows true conditions in the Standard Event Status Register to be reported in the Event Status Bit (ESB) of the Status Byte Register. If a bit is 1 in the Standard Event Status Enable Register and its associated event bit transitions to true, then the ESB of the Status Byte Register is set true. The bit configuration of ESE is the same as the ESR (see *ESR?).

Syntax: *ESE <NRf>

Parameters: 0 to 255

Example: *ESE 48 enables the CME and EXE events of Standard Event Status Register.

Query Syntax: *ESE?

Return Parameters: <NR1>

Query Example: *ESE? returns the content of Standard Event Status Enable Register.

***ESR?, Standard Event Status Register Query**

Description: This query returns the content of the Standard Event Status Register and then clears it.

Query Syntax: *ESR?

Parameters: None

Return Parameters: <NRI>

Query Example: *ESR? returns the content of Standard Event Status Register.

***IDN?, Identification Query**

Description: This query returns ASCII string which organized into four fields separated by commas to identify the ac source.

Query Syntax: *IDN?

Parameters: None

Return Parameters: Field 1: Manufacturer
 Field 2: Model
 Field 3: Serial Number or 0
 Field 4: Firmware Level or equivalent

Query Example: *IDN?

Return Example: CHROMA ATE,6404,0,A.00.01

***OPC, Operation Complete Command**

Description: This command causes the ac source to set the OPC bit of Standard Event Status Register when all pending operations are completed.

Syntax: *OPC

Parameters: None

***OPC?, Operation Complete Query**

Description: This query returns an ASCII "1" when all pending operations are completed.

Query Syntax: *OPC?

Parameters: None

Return Parameters: 1

***RST, Reset Command**

Description: This command resets the ac source to the following states:

OUTP OFF
 CURR:PEAK MAX
 FREQ 60
 VOLT 0
 VOLT:EPR OFF
 VOLT:LIM 300
 VOLT:RANG 150
 VOLT:RANG:AUTO OFF

Syntax: *RST

Parameters: None

Bit configuration of Status Byte Register

Bit position	7	6	5	4	3	2	1	0
Condition	OPER	MSS	ESB	MAV	QUES	---	---	---
		RQS						
Bit Weight	128	64	32	16	8			

Remark: RQS : Request service

MSS : Master Summary Status

ESB : Event Status Bit

MAV : Message Available

QUES : Questionable status

OPER: Operation status

***SRE, Service Request Enable Command**

Description: This command sets the content of the Service Request Enable Register, which determines which events of the Status Byte Register are allowed to set the Master Summary Status (MSS) and the Request Service (RQS) message true. If a bit is 1 in Service Request Enable Register and its associated event bit in Status Byte Register transitions to true, bit 6 of Status Byte Register is then set true.

Syntax: *SRE <NRf>

Parameters: 0 to 255

Example: *SRE 16 enables the MAV bit event to set MSS and RQS bit.

Query Syntax: *SRE?

Return Parameters: <NRI>

Query Example: *SRE? returns the content of Service Request Enable Register.

***STB?, Read Status Byte Query**

Description: This query returns the Status Byte Register. The Status Byte Register can be read with either a serial poll or the *STB? Common query. If it is read with a serial poll, the RQS bit is sent for the bit 6 position and then cleared. If it is read with *STB?, MSS bit is sent but not cleared.

Query Syntax: *STB?

Parameters: None

Return Parameters: <NR1>

Query Example: *STB? returns the content of Status Byte Register.

***TST?, Self-Test Query**

Description: This query causes an internal self-test and reports result. If the ac source complete the self-test without any detected errors, it returns a 0, otherwise it returns a 1. Note that during self-test caused by *TST, the output voltage will reach 300V. Please disconnect any output load.

Query Syntax: *TST?

Parameters: None

Return Parameters: 0 | 1

Query Example: *TST? causes a self-test and reports result.

***WAI, Wait-to-continue**

Description: This command prevents the ac source from executing any further command until all pending operations are completed.

Syntax: *WAI

Parameters: None

6.7 Status Reporting

The ac source follows the status data structure and mechanism described in the IEEE 488.2 Standard Digital Interface for Programmable Instrumentation. Note that undefined bits of all status registers are zero when read.

6.7.1 Questionable Status

The Questionable Status Registers record signals that indicate abnormal operation of the ac source.

- (1) Condition Register: It reflects the present TRUE (1) or FALSE (0) states in its condition bits. It is a read-only register.
- (2) Negative Transition (NTR) Filter: It allows the event bit to be set TRUE when the associated condition changes from TRUE to FALSE. It is cleared at power-on or by the STATus:PRESet command.
- (3) Positive Transition (PTR) Filter: It allows the event bit to be set TRUE when the associated condition changes from FALSE to TRUE. All defined bits are set at power-on or by the STATus:PRESet command.
- (4) Event Register: It latches conditions that are passed by PTR and/or NTR filters. It is cleared at power-on or when be read, or when the *CLS common command is received.
- (5) Enable Register: It selects which event bits in the Event Register will cause the QUEStionable Status summary-message of the Status Byte Register to be TRUE when set. It is cleared at power-on or by the

STATus:PRESet command.

6.7.2 Standard Event Status

The Standard Event Status Register latches conditions described below:

- (1) Bit 7: Power ON (PON). This event bit indicates that an off-to-on transition has occurred in the device's power supply.
- (2) Bit 5: Command Error (CME). A syntax error or semantic error has been detected.
- (3) Bit 4: Execution Error (EXE). A program data is outside the legal range or inconsistent with the ac source's capabilities, or the command could not be executed due to some operation condition.
- (4) Bit 3: Device-Specific Error (DDE). This event bit indicates that an error has occurred which is neither a Command Error, a Query Error, nor an Execution Error.
- (5) Bit 2: Query Error (QYE). An attempt is being made to read data from the output queue when no output is either present or pending, or data in the output queue has been lost.
- (6) Bit 0: Operation Complete (OPC). This event bit is generated in response to the *OPC command. It indicates that the ac source has completed all pending operations.

The Standard Event Status Register is cleared at power-on or when be read, or by the *CLS common command.

The Standard Event Status Enable Register selects which event bits in the Standard Event Status Register may cause the ESB summary-message of the Status Byte Register to be TRUE when set. It is cleared at power-on.

6.7.3 Status Byte Register

The Status Byte Register summarizes summary-messages from other status. Its bit definitions are as follow:

- (1) Bit 3: Questionable Status (QUES) Summary-Message. Its state indicates if one or more of the enabled events defined in Questionable Status have occurred since the last reading or clearing of the Questionable Event Register.
- (2) Bit 4: Message Available (MAV) Queue Summary-Message. Its state indicates whether or not the Output Queue is empty. Whenever the ac source is ready to accept a request by the controller to output data bytes, the MAV summary-message is TRUE.
- (3) Bit 5: Event Status Bit (ESB) Summary-Message. Its state indicates if one or more of the enabled events defined in Standard Event Status have occurred since the last reading or clearing of the Standard Event Status Register.
- (4) Bit 6: Master Summary Status (MSS) Message or Request Service (RQS) Message. The MSS message indicates that at least one summary-message enabled by the Service Request Enable Register occur. The RQS message functions the same as the MSS message except that it is cleared after a serial poll.
- (5) Bit 7: Operation Status (OPER) Summary-Message. The Operation Status Registers are not used in the ac source.

The Status Byte Register can be read with either a serial poll or the *STB? common query. If it is read with a serial poll, the RQS message is sent for the bit 6 position and then cleared. If it is read with the *STB? common query, the MSS message is sent but not changed. The *CLS common command will cause all Status Data Structures (that is, their Event Registers and Error Queue) to be cleared so that the corresponding summary messages are cleared. The Output Queue and its MAV summary message are an exception and are unaffected by *CLS.

The Service Request Enable Register selects which summary-messages in the Status Byte Register may cause the

MSS and RQS message to be TRUE. The undefined bits and bit 6 of the Service Request Enable Register are always zero. When the RQS message is set TRUE, the ac source will send a SRQ message to request service asynchronously from the controller in charge of the GPIB interface. The Service Request Enable Register is cleared at power on.

6.8 Error Messages

As errors are detected, they are placed in a first in, first out queue. The SYSTem:ERRor? query can be used to read back the errors in the queue. If the queue overflows, the last error in the queue is discarded and replaced with error -350,"Queue overflow". When all errors have been read, further error queries will return 0,"No error".

Error Number	Error Description [description/explanation/examples]
0	No error
-100	Command error [generic]
-101	Invalid character
-103	Invalid separator
-104	Data type error
-108	Parameter not allowed [more parameters were received than expected]
-109	Missing parameter [fewer parameters were received than required]
-110	Command header error
-111	Header separator error
-112	Program mnemonic too long [more than 12 characters]
-113	Undefined header [the header is syntactically correct, but undefined]
-120	Numeric data error
-123	Exponent too large [the exponent magnitude was larger than 32000]
-124	Too many digits [more than 255 digits excluding leading zeros]
-128	Numeric data not allowed [the received numeric data is not accepted for the header]
-130	Suffix error
-138	Suffix not allowed
-141	Invalid character data
-144	Character data too long [more than 12 characters]
-148	Character data not allowed
-221	Settings conflict [e.g., enable external program mode while the output voltage range is AUTO]
-222	Data out of range [e.g., set voltage to 200 Volts while the output voltage range is 150V]
-230	Data corrupt or stale
-350	Queue overflow [more than 16 errors]
-410	Query INTERRUPTED [a new program message is received before a response was completely sent]
-420	Query UNTERMINATED [addressed to talk but an incomplete program message was received]
-430	Query DEADLOCKED [output buffer overflow because too many queries]
-440	Query UNTERMINATED after indefinite response [a query was received in the same program message after an indefinite response]
11	Command only used for RS-232C interface

SUPPLEMENT

3.2.6 Power on status :

The 6408/6404 offers the user to set up the parameters of range ,V and F when the power switch is on .

Example : Set the power on status to be 230V , 50Hz .

Action	Display
1. Enter configuration setup as stated in sec.3.2 , if required .	
2. Press 6 , and ENTER	turn on r 150
3. Turn ⊙ to select 300.	turn on r 300
4. Press ENTER	turn on V 0.0
5. Press 2 3 0	turn on V 230.0
6. Press ENTER	turn on F 60.0
7. Press 5 0	turn on F 50.0
8. Press ENTER	turn on r 300
9. Press OUT/QUIT	set up 6
10. Select other setups by numeric keys , or press OUT/QUIT again to exist from setup.	

CORRECTION

page 1-2	Line 22	Line regulation 0.1%
	Line 29	EFFICIENCY typical 75% for 6404
page 3-4	Line 29	Note3: When “I limit” is set as value less than 1A (for 300v range) or 2A (for 150v range),the “I limit” LED keeps blinking. The user should change to a value larger than that.

Chroma[®]
CHROMA ATE INC.
致茂電子股份有限公司

43. Wu-Chuan Road, Wu-Ku Ind. Park,
Taipei Hsien, Taiwan, R.O.C.
台北縣五股鄉五股工業區五權路43號
TEL:886-2-298-3855
FAX:886-2-298-3596