

"SD Series I.I."
X-ray Image Intensifier
E5830SD-P4A
Triple Input Field:
230/160/120mm (9"/ 6"/ 4.5")
Output Image Diameter: 25mm

FEATURING:

- **High Resolution** : 52 Lp/cm
- **High Conversion Factor** : $29 \frac{\text{cd/m}^2}{\mu\text{Gy/s}}$
- **High Contrast Ratio**
 - 10% area contrast** : 30:1
 - 10mm dia. contrast** : 19:1

- "SD Series I.I." E5830SD-P4A is used for medical radiographic diagnosis.
- This X-ray Image Intensifier is intended to be connected with IEC Class I equipment.

"SD Series I.I." E5830SD-P4A has been perfected by the integration of several aspects of advanced technology ;

The input window is of a thin metal plate, which has good X-ray transparency characteristics and reduces X-ray scatter.

It uses a thick input phosphor screen made with an extremely fine pillar shaped structure. This has high X-ray absorption and very high conversion efficiency. In addition, there is a thin output phosphor screen on a single thick-glass output window with an anti-reflective coating, offering very high contrast for small details, very low structure noise and high MTF characteristics.

The E5830SD-P4A, employing these manufacturing techniques, provides outstanding performance in resolution, brightness, contrast and noise.

The E5830SD-P4A is supplied in a housing, which provides mu-metal magnetic shielding and radiation shielding.

PERFORMANCE DATA

Item		N mode	M1 mode	M2 mode		
Central Resolution		52	58	68	Lp/cm	typ.
Conversion Factor (Gx)		29	-	-	(cd/m ²)/(μGy/s)	typ.
		250	-	-	(cd/m ²)/(mR/s)	typ.
Contrast Ratio	10% area	30:1	-	-	-	typ.
	10 mm dia.	19:1	-	-	-	typ.
DQE (IEC standard)		65	-	-	%	typ.

GENERAL DATA➤ **MECHANICAL:**

Item	
Overall Length	338±5 mm
Maximum Diameter	304±2 mm
Nominal Entrance Field Size	
N (9") mode	230 mm min.
Useful Entrance Field Size	
N (9") mode	215 mm min.
M1 (6") mode	160±5 mm
M2 (4.5") mode	120±5 mm
Output Image Diameter	25±0.5 mm
Weight (approx.)	20 kg
Dimensional Outline	Refer to page 4

➤ **POWER SUPPLY:**

Item	
High Voltage Power Supply	
Input Voltage	24±1 Vdc

➤ **ENVIRONMENTAL:**

Item	Under delivery and stock	Under operating
Temperature	-15 to 45 °C	5 to 40 °C
Humidity	10 to 90 %	30 to 85 %
Pressure	50 to 106 kPa	70 to 106 kPa

ELECTRICAL WIRING AND CONNECTING

X-ray image intensifier is operated with 24Vdc input voltage applied to the high voltage power supply. Wiring and connecting are shown as follows.

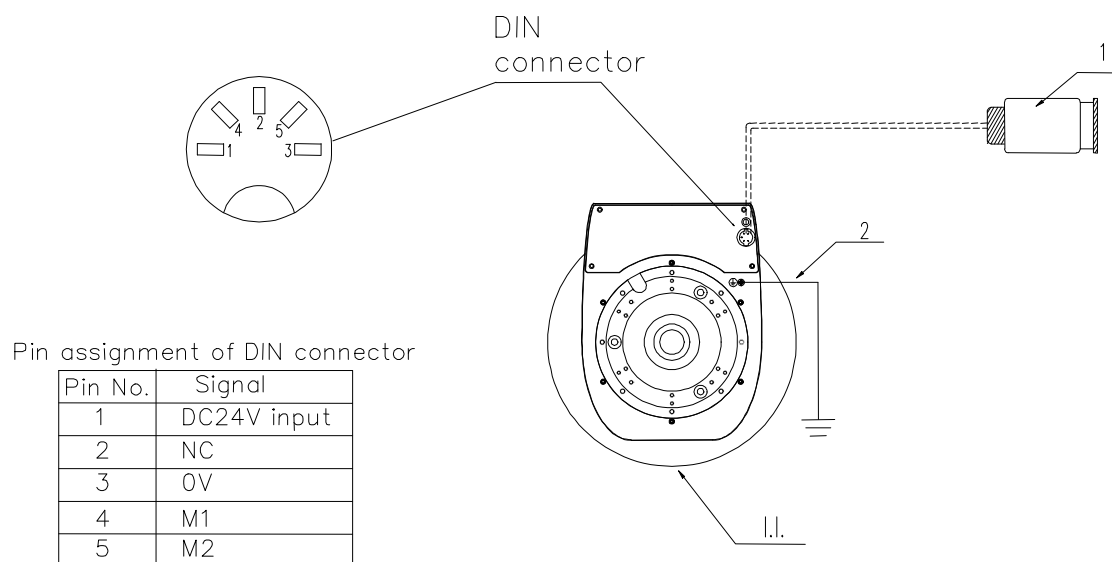

Switching of entrance field size

- * N mode4,5 Open
- * M1 mode..... 1-4 Close (apply DC24V to Pin No.4)
- * M2 mode..... 1-5 Close (apply DC24V to Pin No.5)

1: DC Input / Mode Change Connector x1
 2: GND Cable 3mx1

DIMENSIONAL OUTLINE

Unit: mm

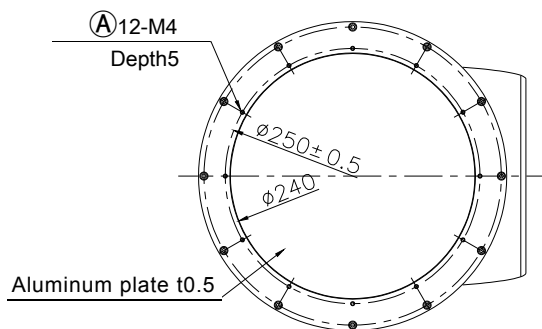
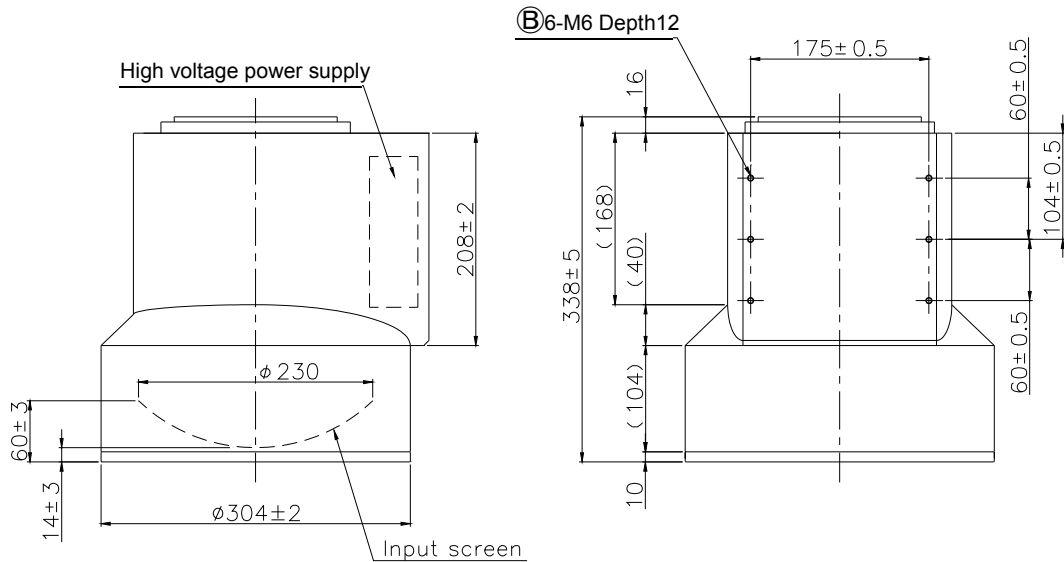
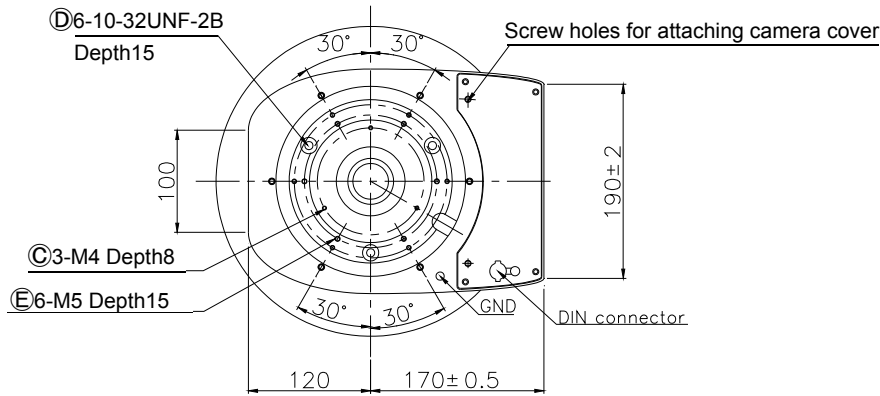

①②: Screw holes for fixing to apparatus
 ③④⑤: Screw holes for attaching objection lens