

"SD Series I.I."  
X-ray Image Intensifier  
**E5764SD-P7A**  
Triple Input Field:  
230/160/120mm (9"/ 6"/ 4.5")  
Output Image Diameter: 20mm

## FEATURING:

- **High Resolution** : 48 Lp/cm
- **High Conversion Factor** :  $28 \frac{\text{cd/m}^2}{\mu\text{Gy/s}}$
- **High Contrast Ratio**
  - 10% area contrast** : 25:1
  - 10mm dia. contrast** : 16:1
- "SD Series I.I." E5764SD-P7A is used for medical radiographic diagnosis.
- This X-ray Image Intensifier is intended to be connected with IEC Class I equipment.

"SD Series I.I." E5764SD-P7A has been perfected by the integration of several aspects of advanced technology ;

The input window is of a thin metal plate, which has good X-ray transparency characteristics and reduces X-ray scatter.

It uses a thick input phosphor screen made with an extremely fine pillar shaped structure. This has high X-ray absorption and very high conversion efficiency. In addition, there is a thin output phosphor screen on a single thick-glass output window with an anti-reflective coating, offering very high contrast for small details, very low structure noise and high MTF characteristics.

The E5764SD-P7A, employing these manufacturing techniques, provides outstanding performance in resolution, brightness, contrast and noise.

The E5764SD-P7A is supplied in a housing, which provides mu-metal magnetic shielding and radiation shielding.

**PERFORMANCE DATA**

Item		N mode	M1 mode	M2 mode		
Central Resolution		48	56	66	Lp/cm	typ.
Conversion Factor (Gx)		28	-	-	(cd/m <sup>2</sup> )/(μGy/s)	typ.
		240	-	-	(cd/m <sup>2</sup> )/(mR/s)	typ.
Contrast Ratio	10% area	25:1	-	-	-	typ.
	10 mm dia.	16:1	-	-	-	typ.
DQE (IEC standard)		65	-	-	%	typ.

**GENERAL DATA**➤ **MECHANICAL:**

Item	
Overall Length	341±5 mm
Maximum Diameter	302±2 mm
Nominal Entrance Field Size	
N (9") mode	230 mm min.
Useful Entrance Field Size	
N (9") mode	215 mm min.
M1 (6") mode	160±5 mm
M2 (4.5") mode	120±5 mm
Output Image Diameter	20±0.5 mm
Weight (approx.)	18 kg
Dimensional Outline	Refer to page 5

➤ **POWER SUPPLY:**

Item	
High Voltage Power Supply	
Input Voltage	24±1 Vdc

➤ **ENVIRONMENTAL:**

Item	Under delivery and stock	Under operating
Temperature	-15 to 45 °C	5 to 40 °C
Humidity	10 to 90 %	30 to 85 %
Pressure	50 to 106 kPa	70 to 106 kPa

**ABSOLUTE MAXIMUM RATINGS**

Item	
Anode Voltage	32 kV
G3 Electrode Voltage	12 kV
Potential Difference between Anode and G3 Electrode	30 kV
Potential Difference between G3 Electrode and G2 Electrode	12 kV
G2 Electrode Voltage	1200 V
G1 Electrode Voltage	250 V
Photocathode Current	
Continuous	0.2 $\mu$ A
Pulsed	2 $\mu$ A
Input X-ray Dose	$8.73 \times 10^{-3}$ Gy/min [1R/min]

## ELECTRICAL WIRING AND CONNECTING

X-ray image intensifier is operated with 24Vdc input voltage applied to the high voltage power supply. Wiring and connecting are shown as follows.

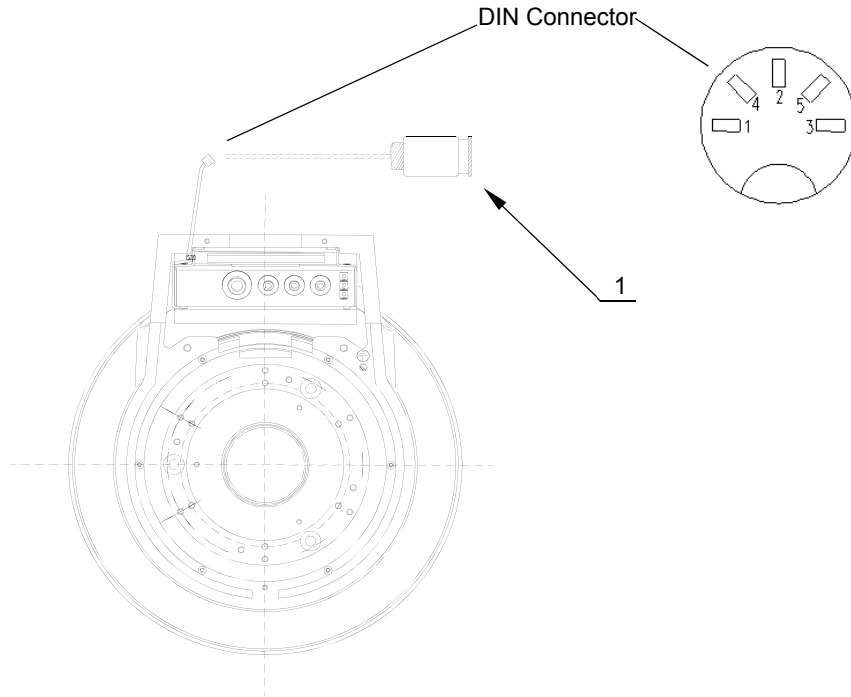

Pin No.	Signal
1	DC24V input
2	NC
3	0V
4	M1
5	M2

**Switching of entrance field size**

- \* N mode    4, 5 Open
- \* M1 mode    1-4 Close (apply DC24V to Pin No.4)
- \* M2 mode    1-5 Close (apply DC24V to Pin No.5)

1. DIN connector..... 1 pc

### DIMENSIONAL OUTLINE

Unit: mm

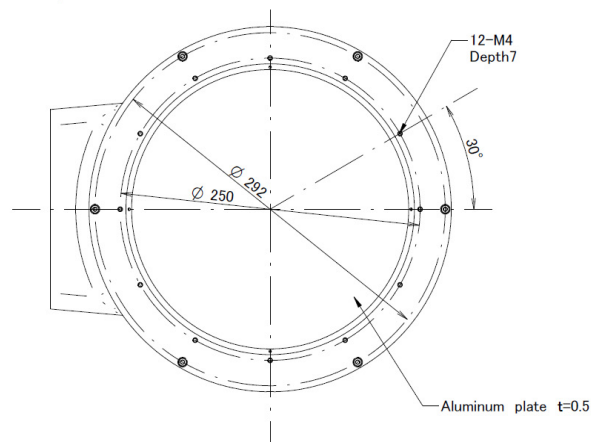
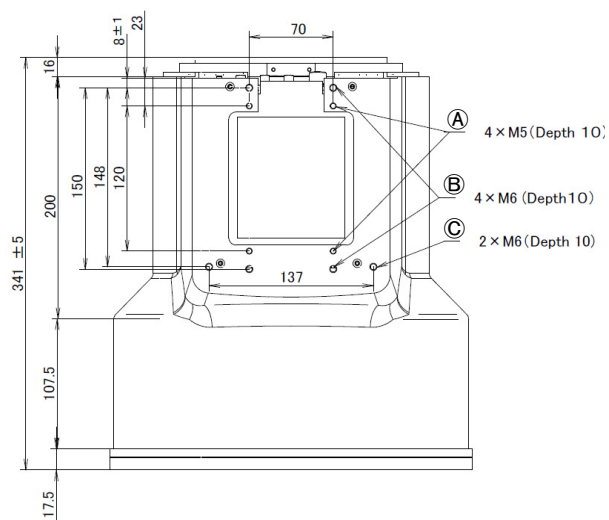
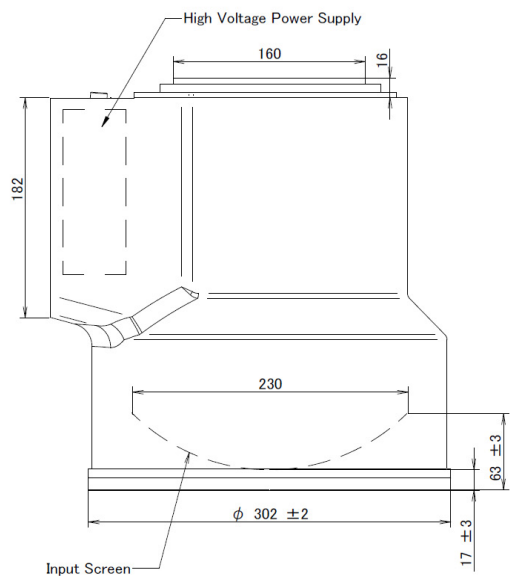
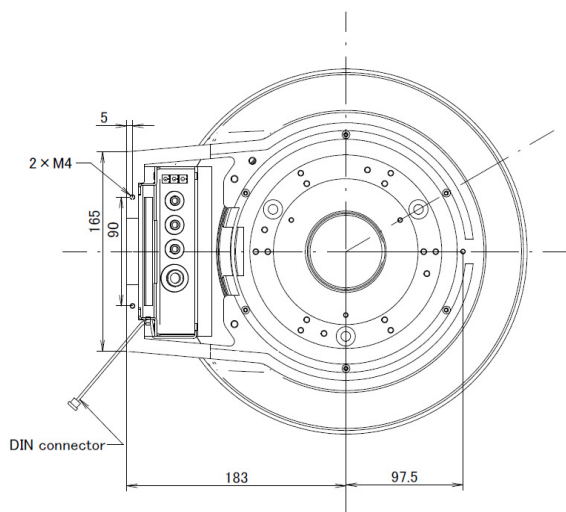

Ⓐ, Ⓑ, Ⓒ: Screw holes for fixing to apparatus



**CANON ELECTRON TUBES & DEVICES CO., LTD.**

Marketing Engineering Group, Sales Department  
1385, Shimoishigami, Otawara-shi, Tochigi 324-8550, Japan  
Tel: +81-287-26-6666 Fax: +81-287-26-6060  
<https://etd.canon>

·The head office of Canon Electron Tubes & Devices Co., Ltd. has been certified to meet all the requirements of Environmental Management System ISO14001.  
·Canon Electron Tubes & Devices Co., Ltd. has been certified to meet all the requirements of Quality Management Systems ISO9001 and ISO13485.  
Product scope is referred to the following URL. <https://etd.canon/eng/company/quality.htm>