



Chunghwa Picture Tubes, Ltd.

Product Specification

To : **Ensky**
Date : 090728

TFT LCD
CLAA070MA0ACW

ACCEPTED BY : (V1.0)

APPROVED BY	CHECKED BY	PREPARED BY
張聖暉	李家銘	簡耀贊

Prepared by :
Product Planning Management Division
Small & Medium TFT Product Business Unit
CHUNGHWA PICTURE TUBES, LTD.

1127 Hopin Rd., Padeh, Taoyuan, Taiwan 334, R.O.C.
TEL: +886-3-3675151 FAX: +886-3-377-3858

Doc.No:	SPEC_CLAA070MA0ACW_V1.0_Ensky_090728	Issue Date:	2009/06/17
---------	--------------------------------------	-------------	------------

REVISION STATUS

Revision Notice	Description	Page	Rev. Date
0.0	First revision (Tentative)	--	2008/10/23
0.1	Revise the TFT-LCD Current Consumption	6	2008/12/16
0.1	Revise the TFT-LCD Power Supply Voltage	6	2008/12/16
0.2	Revise the Power Consumption	4	2008/12/17
0.2	Revise the Module Weight	4	2008/12/17
0.2	Revise the Backlight Table	7	2008/12/17
0.2	Revise the CN2	10	2008/12/17
0.2	Revise the Front Side	14	2008/12/17
0.2	Revise the Rear Side	15	2008/12/17
0.2	Revise the Measuring Point	17	2008/12/17
0.3	Revise the Gamma Voltage	6	2008/12/19
0.4	Revise the Common Power Supply Voltage	6	2008/12/23
0.4	Revise the Gamma Voltage	6	2008/12/23
0.5	Revise the ESD	5	2008/12/26
0.5	Revise the Timing Specification	11	2008/12/26
0.6	Revise the LED Circuit Diagram	9	2009/02/16
0.6	Revise the Color Coordinate	15	2009/02/16
0.7	Revise the Timing Specification	10	2009/02/19
0.7	Revise the Optical Characteristics	14	2009/02/19
0.8	Revise the Common Power Supply Voltage	6	2009/04/29
0.8	Revise the Gamma Voltage	6	2009/04/29
0.8	Revise the Front Side	13	2009/04/29
0.8	Revise the Optical Characteristics	15	2009/04/29
0.8	Revise the Electrostatic Discharge	17	2009/04/29
0.9	Revise LED voltage	7	2009/6/17
0.9	Revise the Front Side	13	2009/6/17
1.0	Add the Driver IC source	4	2009/7/28

Contents

1. OVERVIEW	4
2. ABSOLUTE MAXIMUM RATINGS	5
3. ELECTRICAL CHARACTERISTICS	6
3.1 TFT-LCD Power Supply Voltage.....	6
3.2 TFT-LCD Current Consumption.....	6
3.3 Power 、 Signal Sequence	7
3.4 Backlight.....	7
4. INTERFACE CONNECTION	8
4.1 CN1.....	8
4.2 CN2.....	9
5. INPUT SIGNAL	10
5.1 Timing Specification	10
5.2 Timing Chart.....	10
6. MECHANICAL DIMENSION	13
6.1 Front Side	13
6.2 Rear Side.....	14
7. OPTICAL CHARACTERISTICS	15
8. RELIABILITY TEST	17
8.1 Temperature and Humidity	17
8.2 Shock and Vibration.....	17
8.3 Electrostatic Discharge.....	17
8.4 Judgment Standard.....	17

1. OVERVIEW

CLAA070MA0ACW is 7" color TFT-LCD (Thin Film Transistor Liquid Crystal Display) module composed of LCD panel, driver ICs , control circuit and LED backlight.

The 7" screen produces 800×RGB×600 resolution image. The LCD is drivered by a single input voltage (3.3 V).

General specification are summarized in the following table:

ITEM	SECIFICATION
Display Area (mm)	141.6(H)*106.2(V)
Number of Pixels	800(H) × 3(RGB) ×600(V)
Pixel Pitch (mm)	0.177 (H) × 0.177 (V)
Color Pixel Arrangement	RGB vertical stripe
Display Mode	Normally white, TN
Number of color	16M
Viewing Direction	6 o'clock
Response Time (Tr+Tf)	20 ms (typ)
Brightness (cd/m ²)	250 nit (typ)
Viewing Angle (CR ≥ 10)	140 degree (Horizontal) 120 degree (Vertical)
Electrical Interface	TTL
Power Consumption (W)	1.4 W(typ.)
Outline Dimension (mm)	154(H)*119.2(V)*5.1(D)
Module Weight (g)	165 g(typ)
Backlight	LED
Surface Treatment	Anti-Glare , Surface hardness: 3H
Driver IC Source	Novatek, Himax, Stornix

2. ABSOLUTE MAXIMUM RATINGS

The following values are maximum operation conditions. If exceeded, it may cause faulty operation or damage.

ITEM	SYMBOL	MIN.	MAX.	UNIT	NOTE
Digital Power Supply Voltage	VCC	-0.3	5	V	
Analog Power Supply Voltage	AVDD	-0.5	15	V	
Gate On Voltage	VGH	-0.3	40	V	
Gate Off Voltage	VGL	-20	0.3	V	
ESD	VESDc	-200	+200	V	Note1
	VESDm	-15K	+15K	V	Note1
Forward Current (per LED)	If		30	mA	
Reverse Voltage (per LED)	VR		5	V	
Pulse forward current (per LED)	I _{fp}		100	mA	Note2

【Note】 :

*1) Test Conditions : IEC 61000-4-2

 VESDc : Contact discharge to input connector

 VESDm : Contact discharge to module

*2) I_{fp} Conditions : Pulse Width \leq 10msec ; Duty \leq 1/10

3. ELECTRICAL CHARACTERISTICS

3.1 TFT-LCD Power Supply Voltage

Ta=25°C

ITEM	SYMBOL	MIN.	TYP.	MAX.	UNIT	NOTE
Digital Power Supply Voltage	VCC	3	3.3	3.6	V	
Analog Power Supply Voltage	AVDD	9.4	9.6	9.8	V	
Gate On Power Supply Voltage	VGH	17	18	19	V	
Gate Off Power Supply Voltage	VGL	-6.6	-6	-5.4	V	
Common Power Supply Voltage	VCOM	2.6	2.7	2.8	V	Note1
Gamma Voltage	V1	-	8.68	-	V	
	V2	-	7.05	-	V	
	V3	-	6.62	-	V	
	V4	-	6.26	-	V	
	V5	-	5.178	-	V	
	V6	-	3.978	-	V	
	V7	-	2.896	-	V	
	V8	-	2.536	-	V	
	V9	-	2.106	-	V	
	V10	-	0.476	-	V	
Input Signal Voltage	VIH	0.7VCC	-	VCC	V	
	VIL	GND	-	0.3VCC	V	

【Note】 : *1) Please adjust VCOM to make the flicker level be minimum.

3.2 TFT-LCD Current Consumption

ITEM	SYMBOL	CONDITION	MIN.	TYP.	MAX.	UNIT	NOTE
Gate on Power Supply Current	IVGH	VGH =18V		0.5	1	mA	【Note1】
Gate off Power Supply Current	IVGL	VGL= -6V		0.5	1	mA	【Note1】
Digital Power Supply Current	IVCC	VCC = 3.3V		5	10	mA	【Note1】
Analog Power Supply Current	IAVDD	AVDD = 9.6V		20	25	mA	【Note1】
Total Power Consumption	PC			220.5	297	mW	【Note1】

【Note】 : *1) Typical : Under 64 gray pattern , Maximum : Under black pattern ◦



(a) 64 Gray Pattern

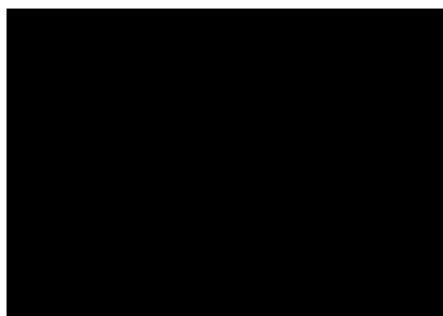

(b) Black Pattern

3.3 Power 、 Signal Sequence

Power On : VCC→AVDD/VGL→VGH
 Power Off : VGH→AVDD/VGL→VCC

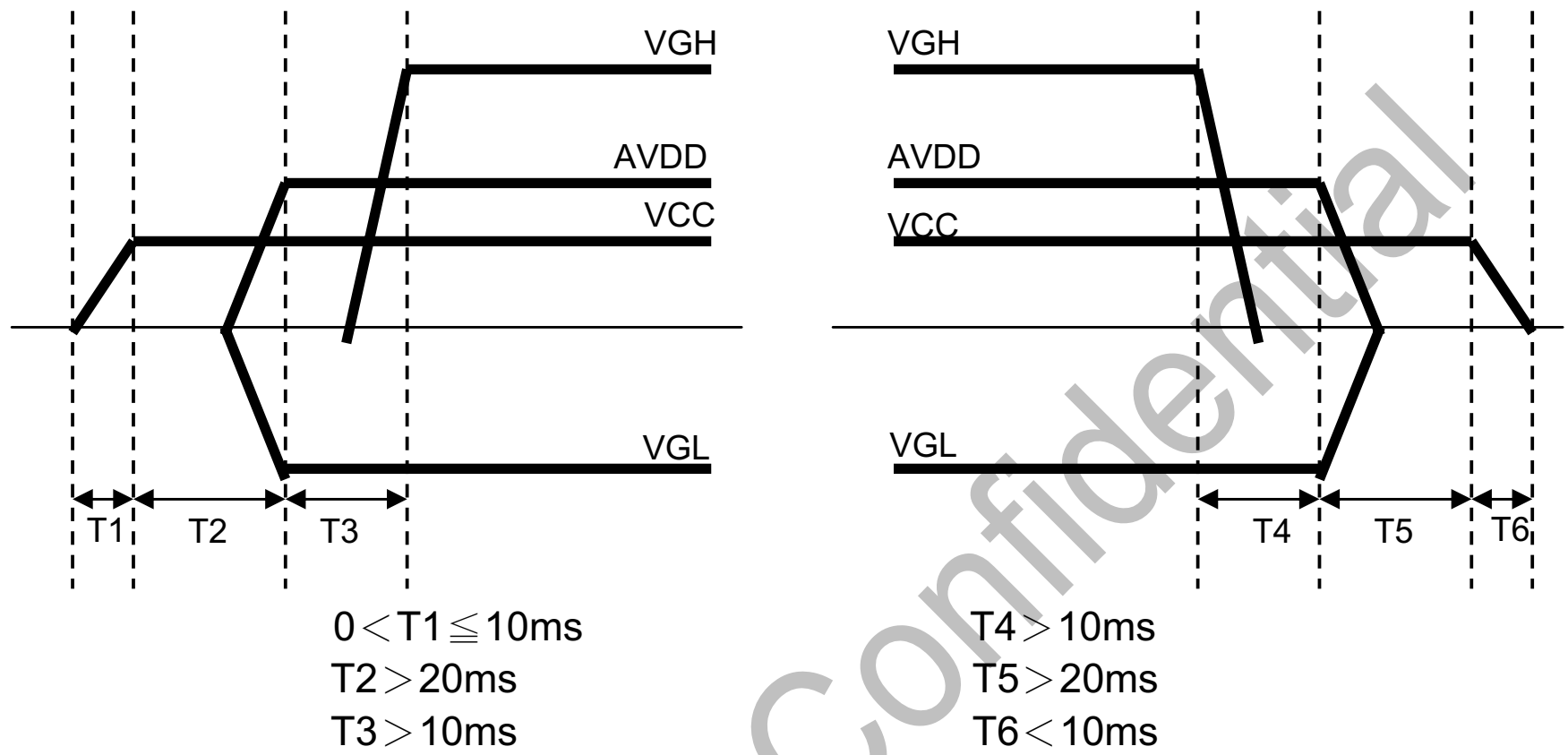

3.4 Backlight

Ta=25°C

ITEM	SYMBOL	MIN.	TYP.	MAX.	UNIT	NOTE
LED current	IL		120	-	Ma	
LED voltage	VL	8.7	9.9	10.95	V	
Power consumption	WL		1.188	-	W	
Lifetime	-	10000			Hr	

【Note】 :

*1)LED Circuit Diagram :

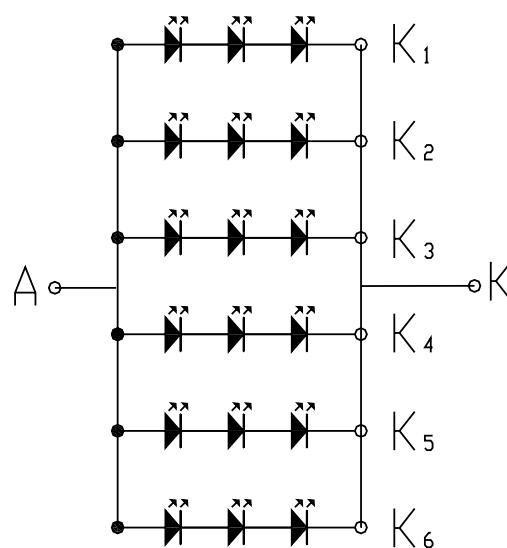

*2) A : Anode(+) , K : Cathode(-)

*3) LED control suggested fixed current.

*4) Definition of the LED life time : Luminance will decay less than 50%

4. INTERFACE CONNECTION

4.1 CN1

Pin NO.	SYMBOL	DESCRIPTION
1	AGND	Analog Ground
2	AVDD	Analog Power
3	VCC	Digital Power
4	R0	Data Input(LSB)
5	R1	Data Input
6	R2	Data Input
7	R3	Data Input
8	R4	Data Input
9	R5	Data Input
10	R6	Data Input
11	R7	Data Input(MSB)
12	G0	Data Input(LSB)
13	G1	Data Input
14	G2	Data Input
15	G3	Data Input
16	G4	Data Input
17	G5	Data Input
18	G6	Data Input
19	G7	Data Input(MSB)
20	B0	Data Input(LSB)
21	B1	Data Input
22	B2	Data Input
23	B3	Data Input
24	B4	Data Input
25	B5	Data Input
26	B6	Data Input
27	B7	Data Input(MSB)
28	DCLK	Clock input
29	DE	Data Enable signal · Active High to enable the data input bus
30	HSD	Horizontal sync input. Negative polarity
31	VSD	Vertical sync input. Negative polarity
32	MODE	DE/SYNC mode select. Normally pull high H: DE mode. L: HSD/VSD mode
33	RSTB	Global reset pin. Active low to enter reset state. Suggest to connecting with an RC reset circuit for stability. Normally pull high.(R=47KΩ · C=1 μ)
34	STBY	Standby mode, normally pull high STBYB="1", normal operation STBYB="0", timing control, source driver will turn off, all output are high-Z
35	SHLR	Left or Right Display Control
36	VCC	Digital Power
37	UPDN	Up / Down Display Control
38	GND	Digital Ground
39	AGND	Analog Ground
40	AVDD	Analog Power
41	VCOM	Common Voltage
42	DITH	Dithering function enable control. Normally pull high DITHB = "1", Disable internal dithering function DITHB = "0", Enable internal dithering function · LSB0 and LSB1 connect to ground.
43	NC	Not connect
44	NC	Not connect
45	V10	Gamma correction voltage reference
46	V9	Gamma correction voltage reference
47	V8	Gamma correction voltage reference

48	V7	Gamma correction voltage reference
49	V6	Gamma correction voltage reference
50	V5	Gamma correction voltage reference
51	V4	Gamma correction voltage reference
52	V3	Gamma correction voltage reference
53	V2	Gamma correction voltage reference
54	V1	Gamma correction voltage reference
55	NC	Not connect
56	VGH	Positive Power for TFT
57	VCC	Digital Power
58	VGL	Negative Power for TFT
59	GND	Digital Ground
60	NC	Not connect

【Note】 : *1) Function is controled by UPDN and SHLR.

UPDN	SHLR	FUNCTION
0	1	Normal Display
0	0	Left / Right Contrary
1	1	Up / Down Reverse
1	0	Left / Right Contrary , Up / Down Reverse

4.2 CN2

Backlight side connector: BHSR-02VS-1(JST)

Mating connector: SM02B-BHSS-1(JST)

Pin No.	SYMBOL	FUNCTION	NOTE
1	CTH	VBLH(High voltage)	
2	CTL	VBLL(Low voltage)	

5. INPUT SIGNAL

5.1 Timing Specification

	ITEM	SYMBOL	MIN.	TYP.	MAX.	UNIT	NOTE
DCLK	Dot Clock	$1/t_{CLK}$	35	40	45	MHz	
	DCLK pulse duty	T_{cwh}	40	50	60	%	
DE	Setup Time	T_{esu}	8	-	-	ns	
	Hold time	T_{ehd}	8	-	-	ns	
	Horizontal Period	t_H	980	1000	1020	t_{CLK}	
	Horizontal Valid	t_{HA}	800				
	Horizontal Blank	t_{HB}	180	200	220	t_{CLK}	
	Vertical Period	t_V	650	660	670	t_H	
	Vertical Valid	t_{VA}	600				
	Vertical Blank	t_{VB}	50	60	70	t_H	
SYNC	HSYNC Setup Time	T_{hst}	8	-	-	ns	
	HSYNC Hold Time	T_{hhd}	8	-	-	ns	
	VSYNC Setup Time	T_{vst}	8	-	-	ns	
	VSYNC Hold Time	T_{vhd}	8	-	-	ns	
	Horizontal Period	t_h	980	1000	1020	t_{CLK}	
	Horizontal Pulse Width	t_{hpw}	-	40	-	t_{CLK}	$t_{hb} + t_{hpw} = 88DCLK$ is fixed
	Horizontal Back Porch	t_{hb}	-	48	-	t_{CLK}	
	Horizontal Front Porch	t_{hfp}	92	112	132	t_{CLK}	
	Horizontal Valid	t_{hd}	800				
	Vertical Period	t_v	650	660	670	t_h	
	Vertical Pulse Width	t_{vpw}	-	3	-	t_h	$t_{vpw} + t_{vb} = 39t_h$ is fixed
	Vertical Back Porch	t_{vb}	-	36	-	t_h	
	Vertical Front Porch	t_{vfp}	18	28	38	t_h	
Vertical Valid	t_{vd}	600					
DATA	Setup Time	T_{dsu}	8	-	-	ns	
	Hold Time	T_{dhd}	8	-	-	ns	

5.2 Timing Chart

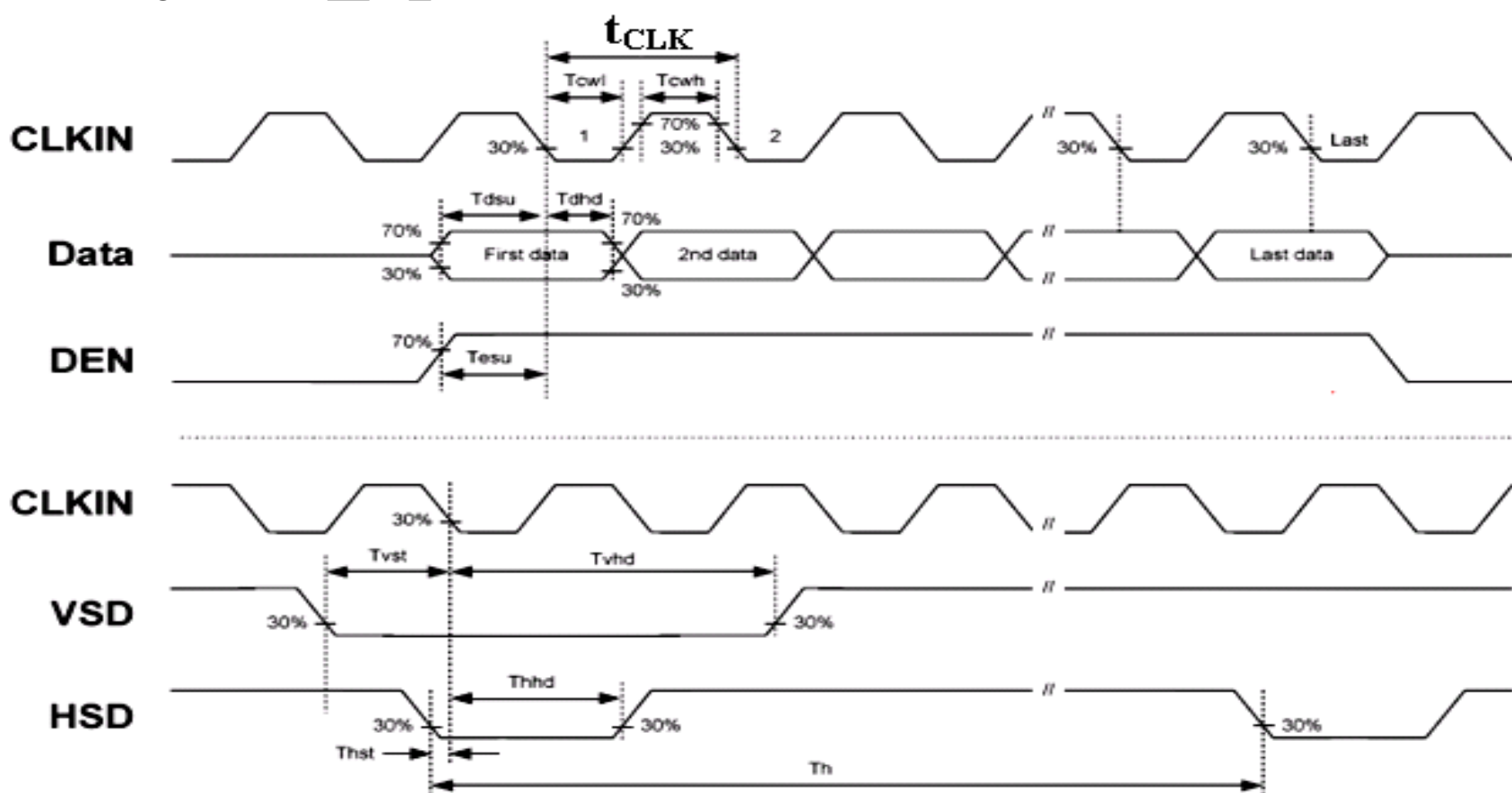

DE mode

(1)Horizontal Timing :

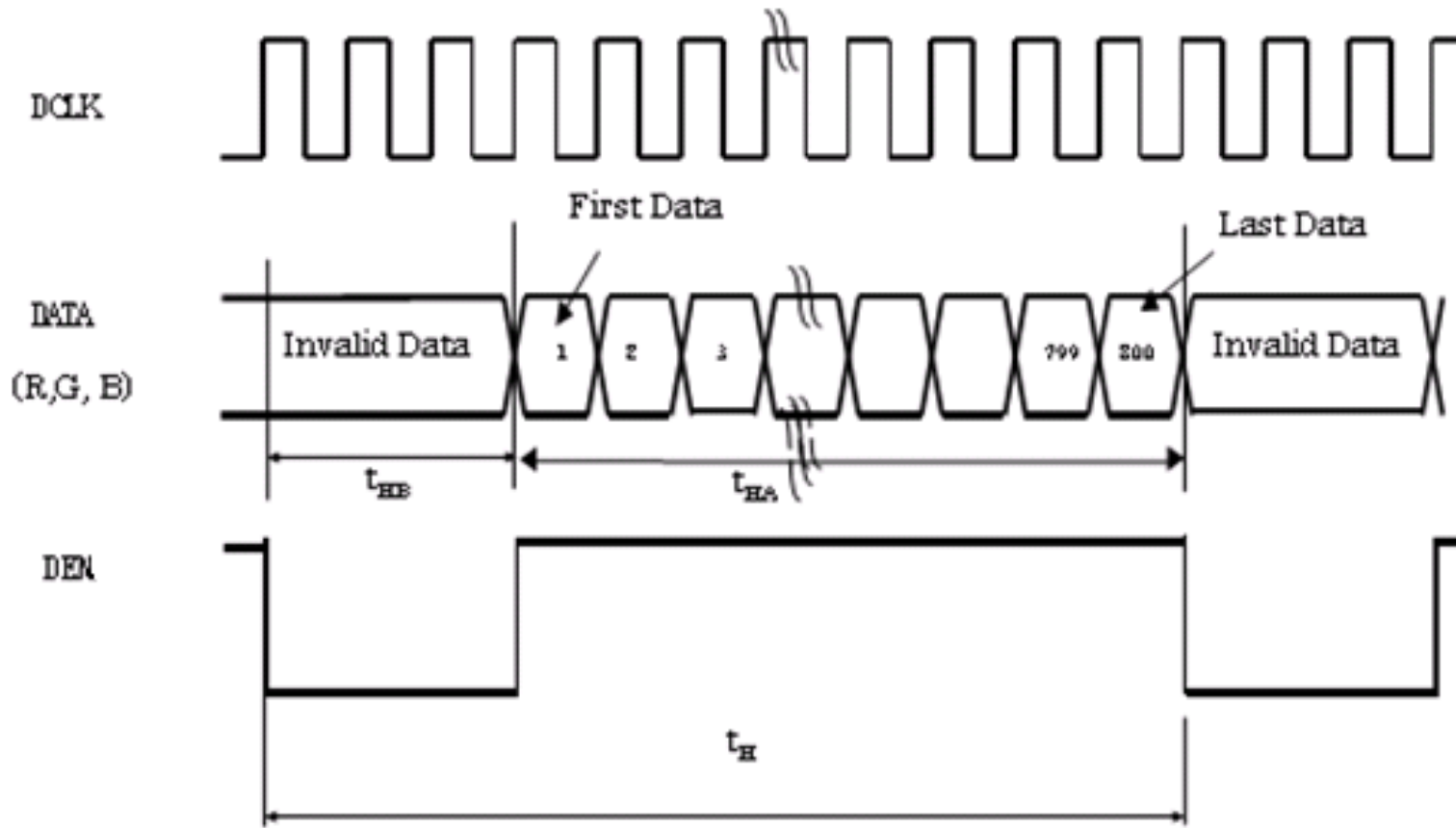

(2)Vertical Timing :

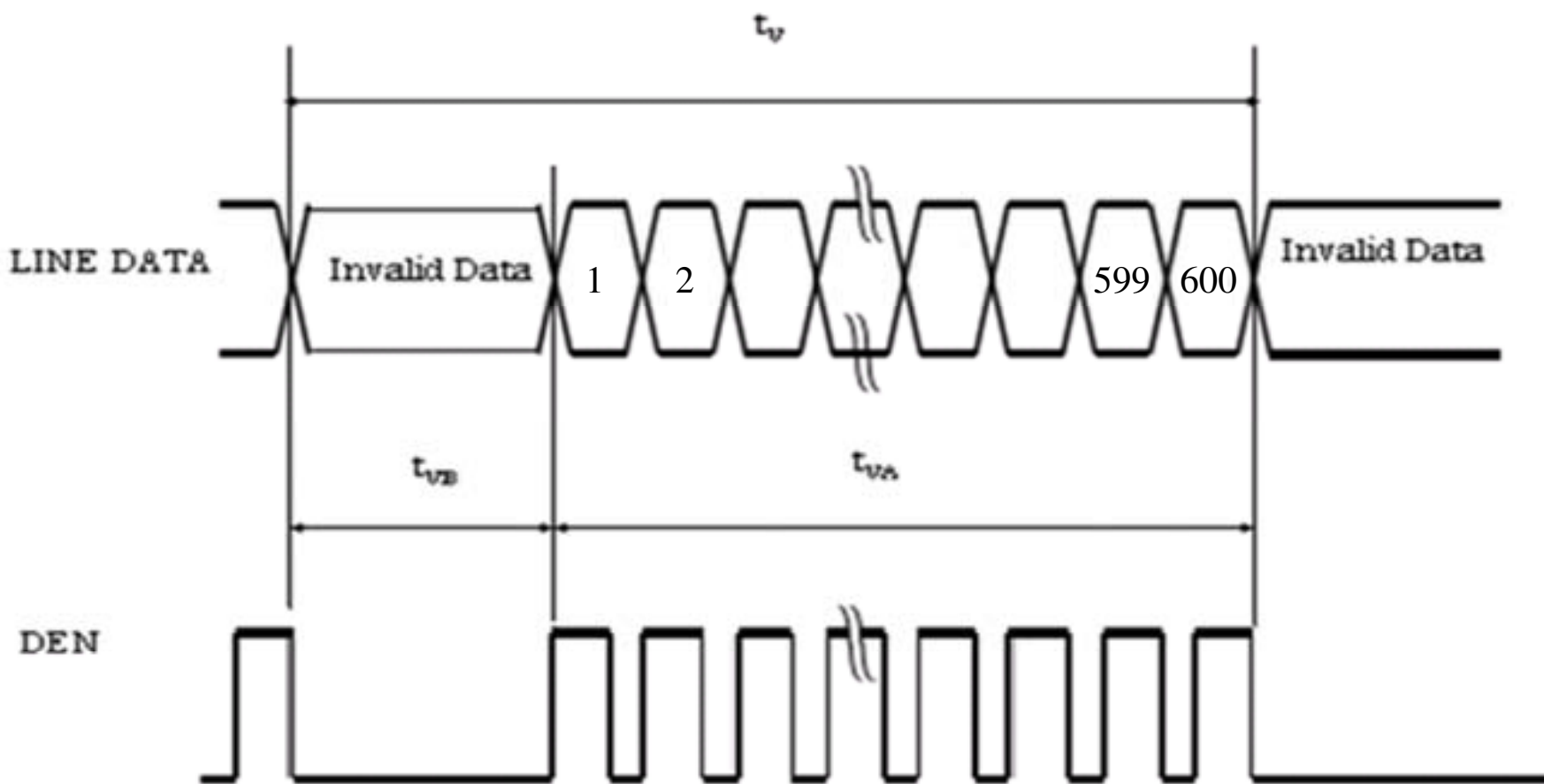

SYNC mode

(1)Horizontal Timing :

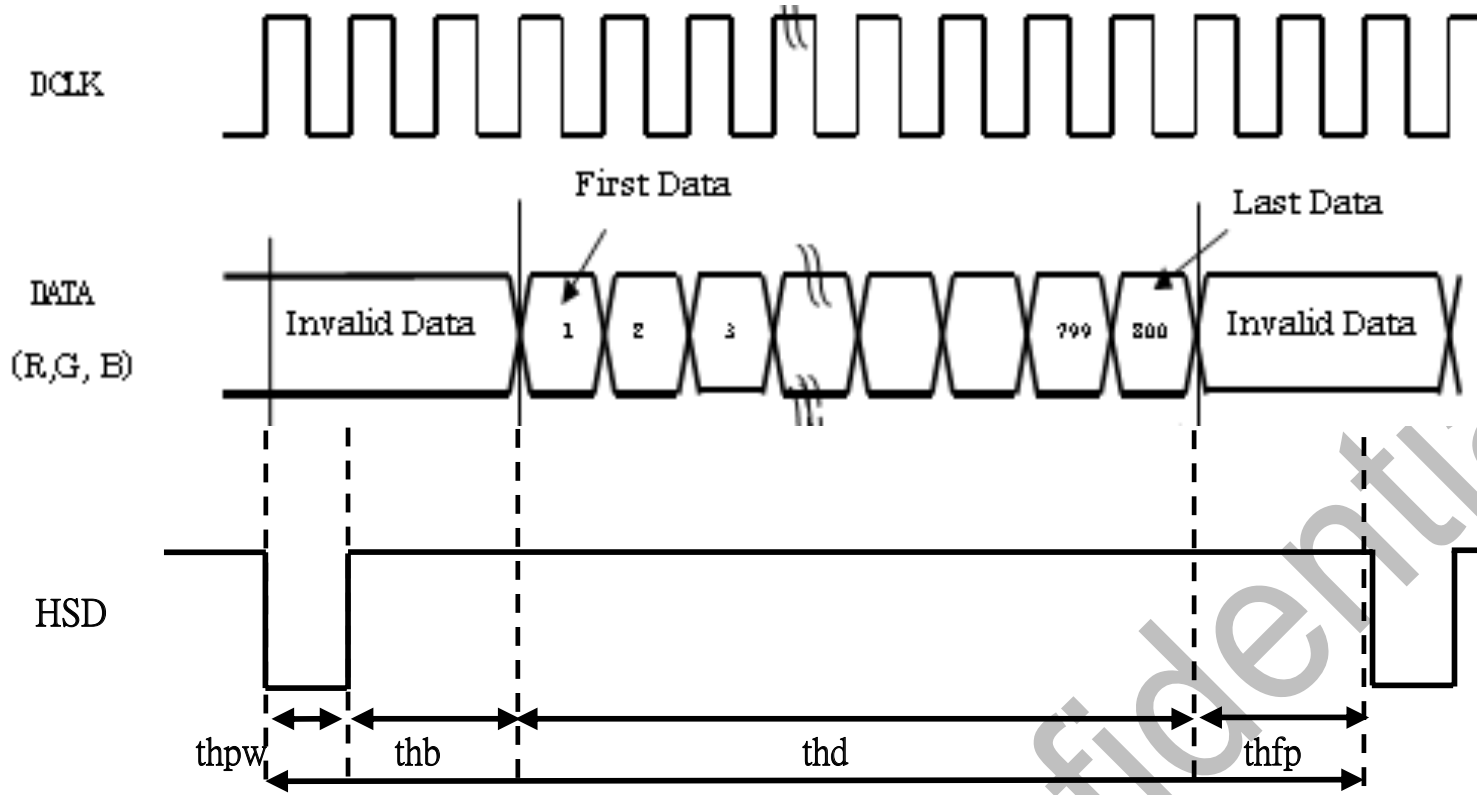

(2)Vertical Timing :

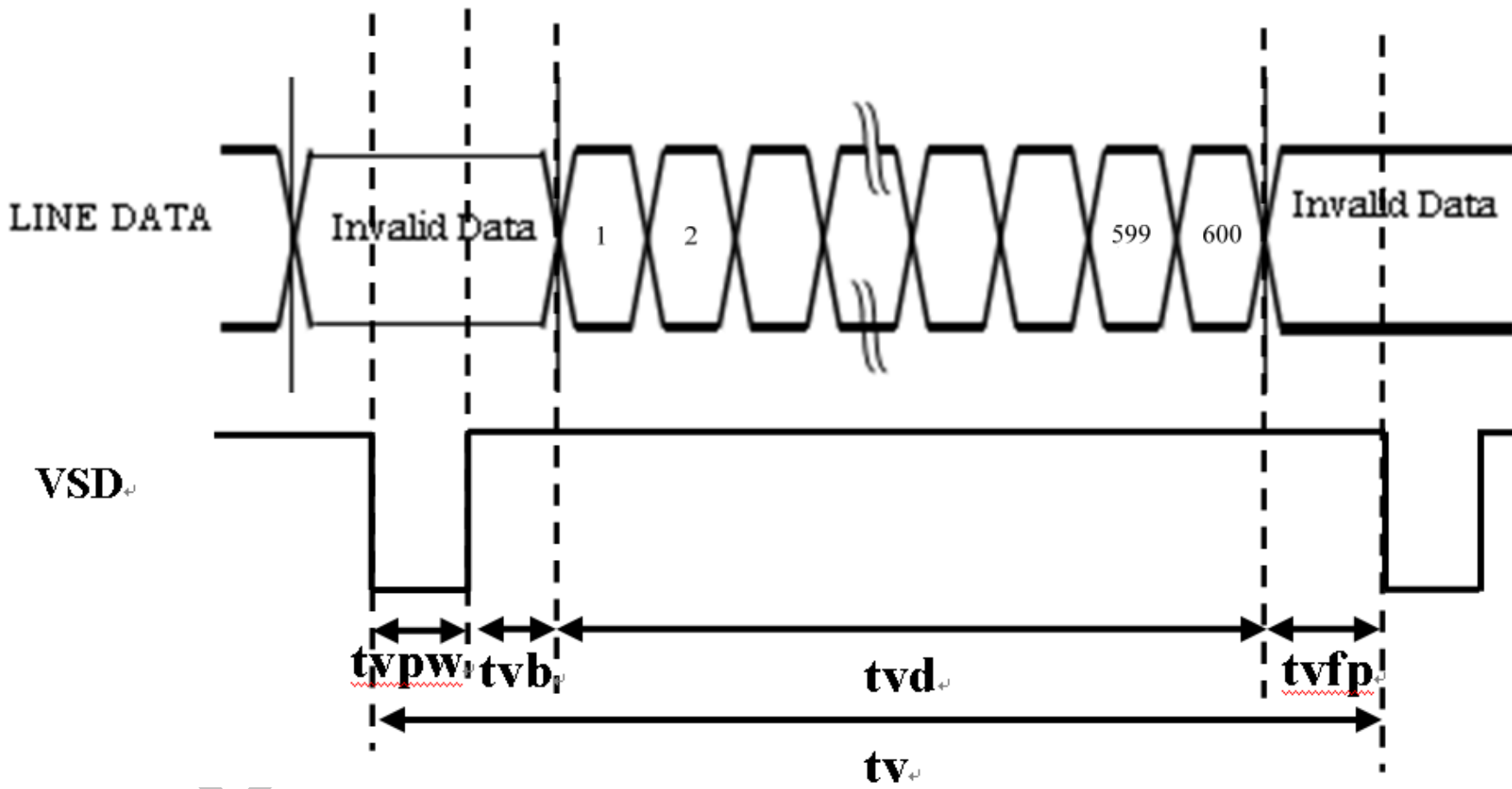

6. MECHANICAL DIMENSION

6.1 Front Side

[Unit : mm]

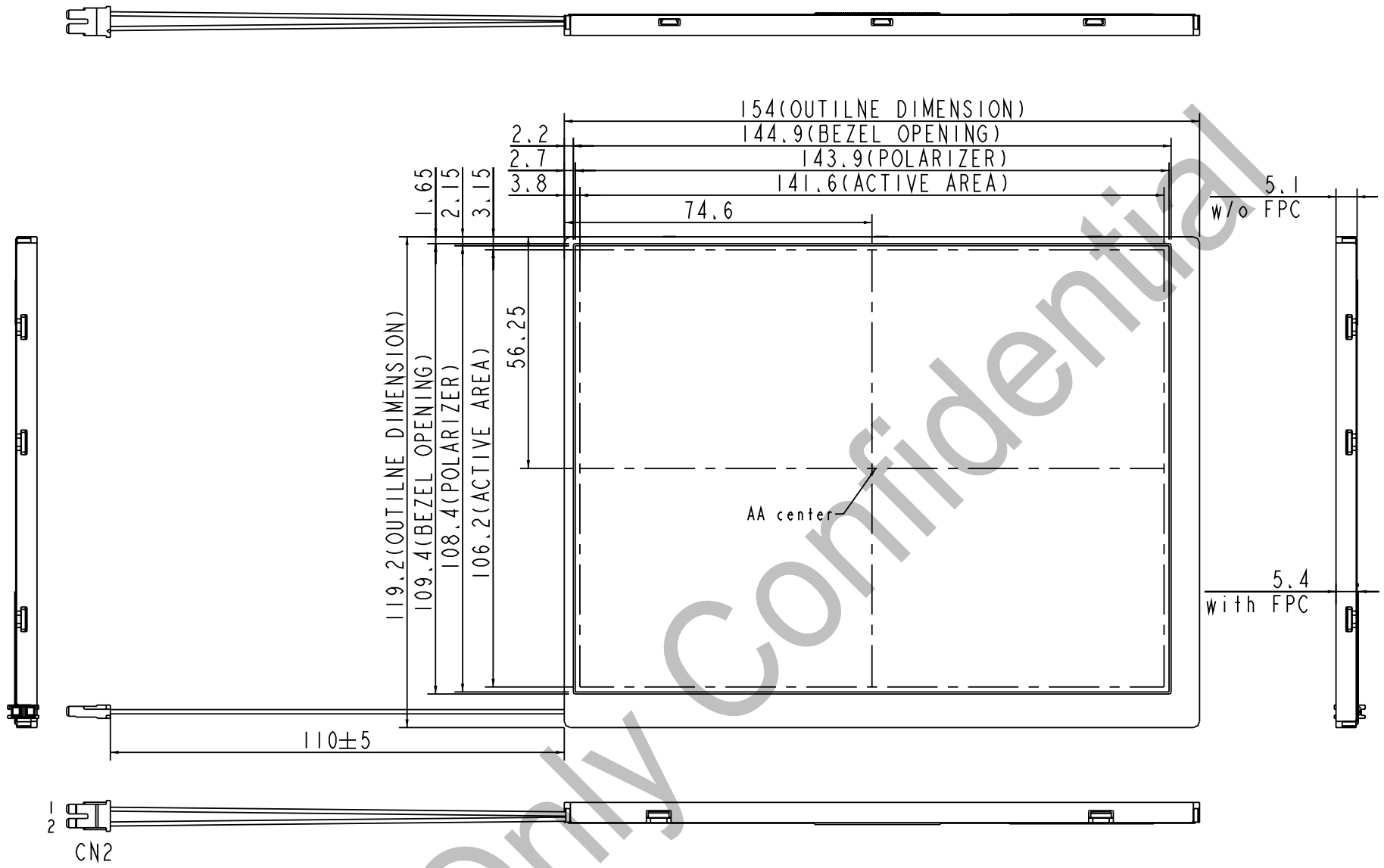

NOTE : General Tolerance = ±0.3 mm

6.2 Rear Side

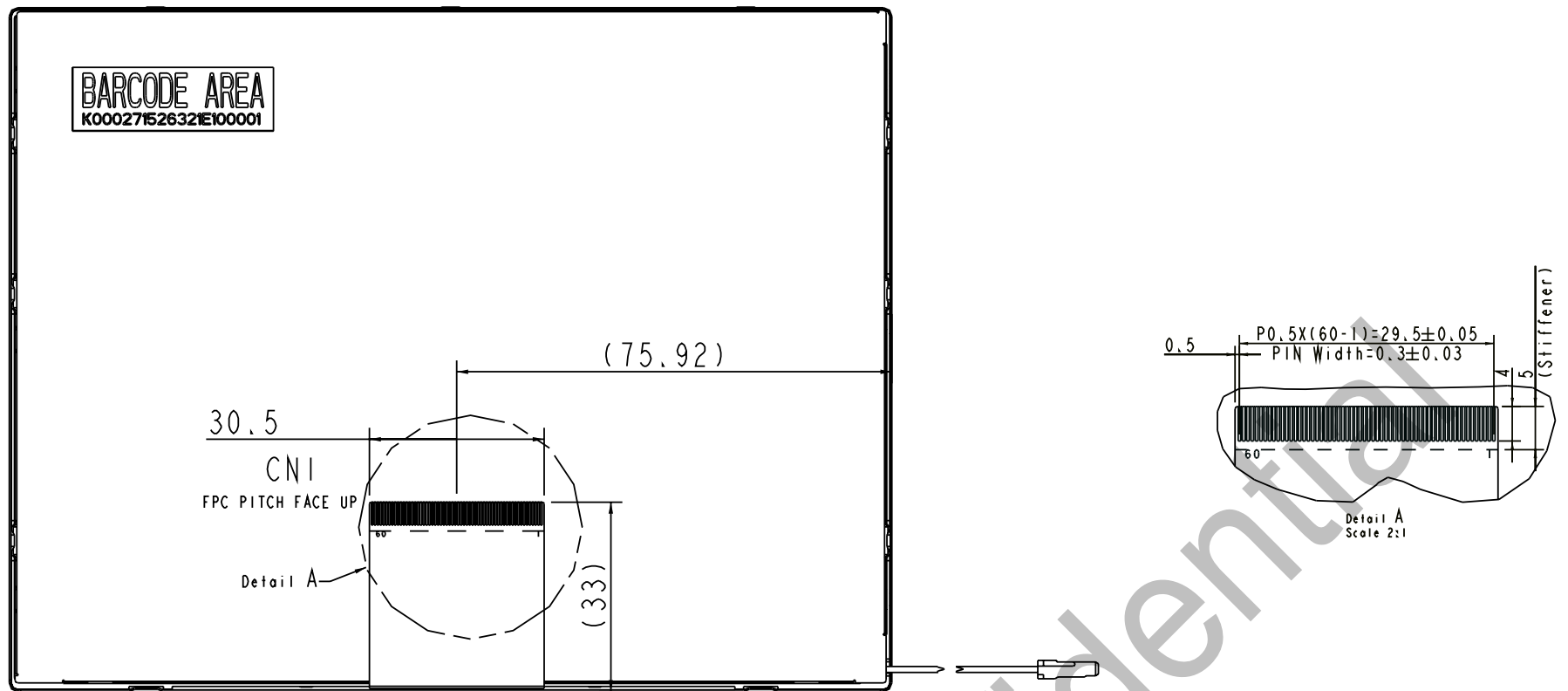

NOTE : General Tolerance = ± 0.3 mm

Ensky Only Confidential

7. OPTICAL CHARACTERISTICS

ITEM		SYMBOL	CONDITION	MIN.	TYP.	MAX.	UNIT	NOTE
Contrast (CEN)		CR	Point-5	400	500	-	-	*1)*2)*3)
Luminance (CEN)		Lw	Point-5	200	250		cd/m ²	*1)*3)
Luminance Uniformity		ΔL		70	80	-	%	*1)*3)
Response Time (White - Black)		Tr +Tf	Point-5	-	20	35	ms	*1)*3)*5)
View angle	Horizontal		CR ≥ 10 Point-5	120	140	-	°	*1)*2)*4)
	Vertical			100	120	-	°	*1)*2)*4)
Color Coordinate	White	Wx	Point-5	0.273	0.313	0.353	-	*1)*3)
		Wy		0.289	0.329	0.369		
	Red	Rx		0.556	0.596	0.636		
		Ry		0.294	0.334	0.374		
Green	Gx	0.300	0.340	0.380				
	Gy	0.542	0.582	0.622				
Blue	Bx	0.111	0.151	0.191				
	By	0.053	0.093	0.133				

【Note】 :

These items are measured by BM-5A (TOPCON) in the dark room. (no ambient light).

*1) condition of measurement : 25 °C ± 2 °C , 60± 10%RH , dark room below 10 Lux ,
viewing cone=2° , VCC=3.3V or IL=120mA , after 10 minutes operation ◦

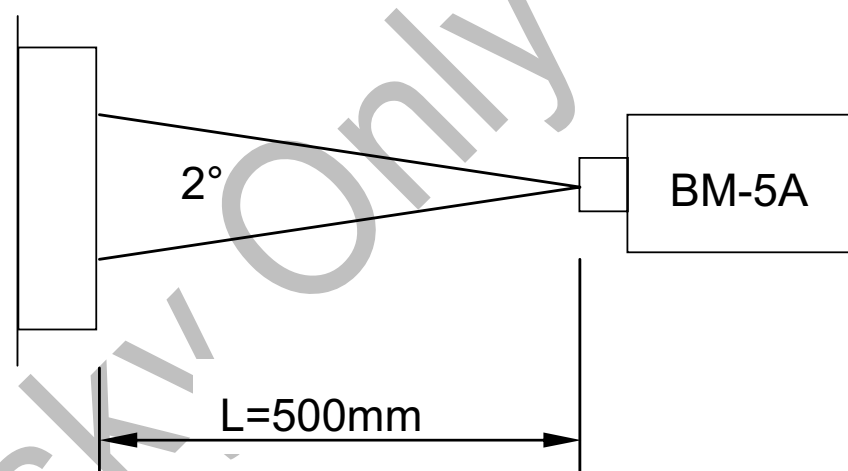

*2) Definition of contrast ratio :

$$\text{Contrast Ratio (CR)} = (\text{White}) \text{ Luminance of ON} \div (\text{Black}) \text{ Luminance of OFF}$$

*3) Definition of Luminance Uniformity :

Measure maximum luminance L(MAX) and minimum luminance L(MIN) on the 9 points as Fig.8-1 (#1~#9point).

Luminance Uniformity is calculated with the following formula :

$$\Delta L = (L(MIN) \div L(MAX)) \times 100\%$$

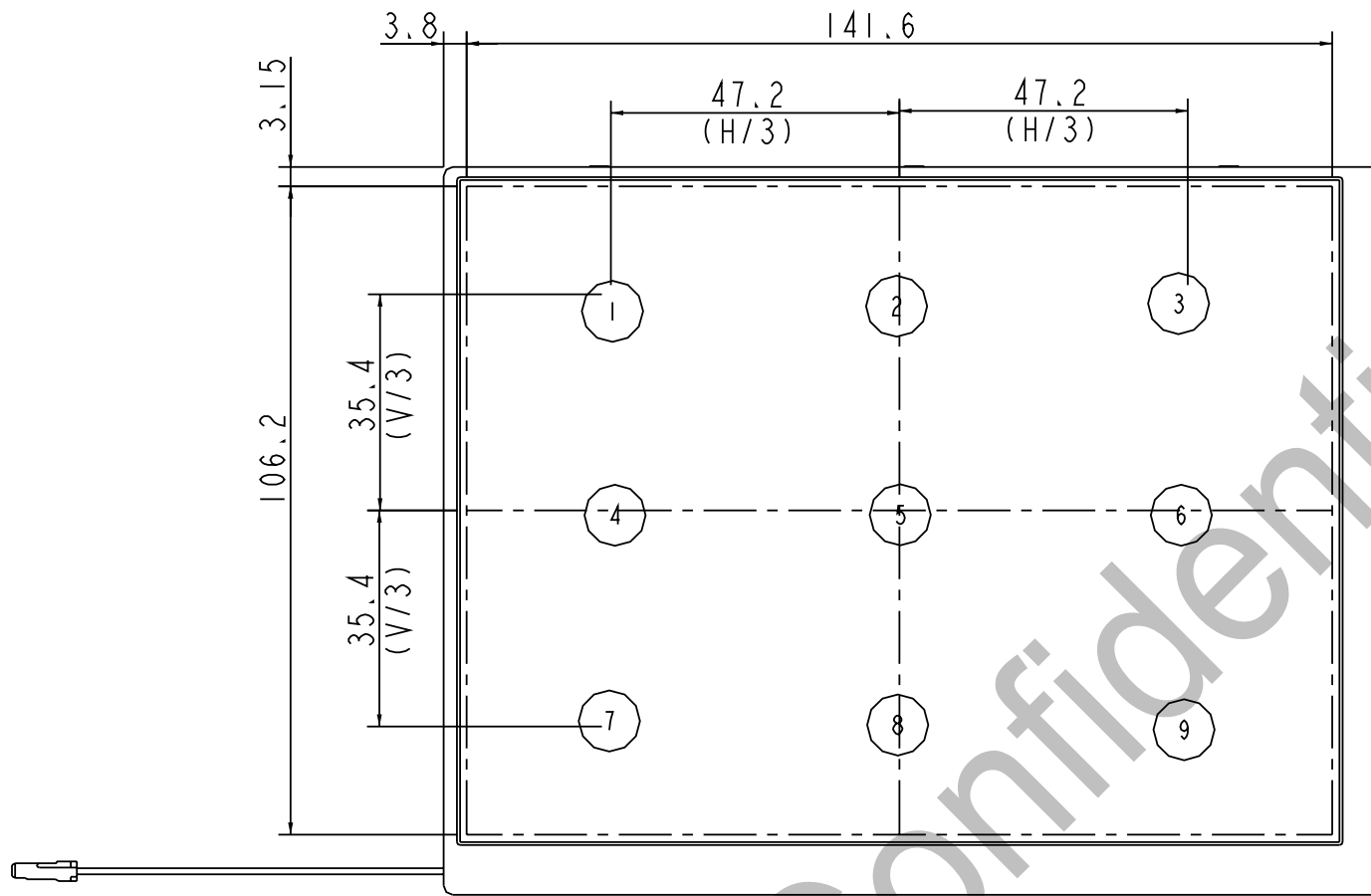

Fig.8-1 Measuring point

*4) Definition of Viewing Angle(θ, ψ), refer to Fig.8-2 as below :

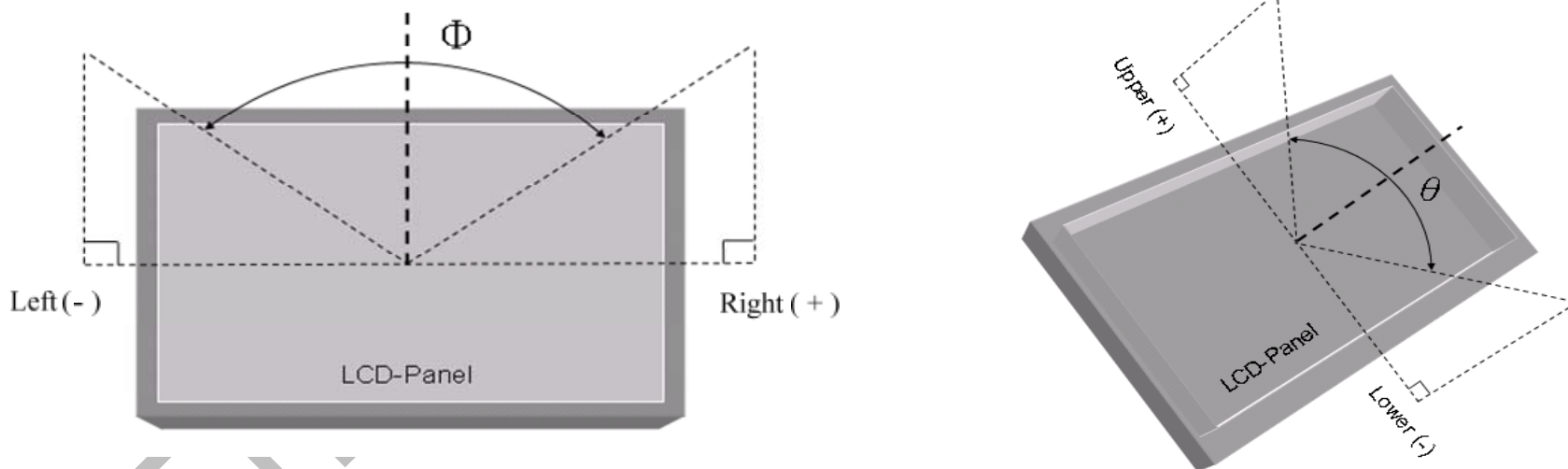

Fig.8-2 Definition of Viewing Angle

*5) Definition of Response Time.

The response time is defined as the time interval between the 10% and 90% amplitudes. Refer to Fig.8-3 as below.

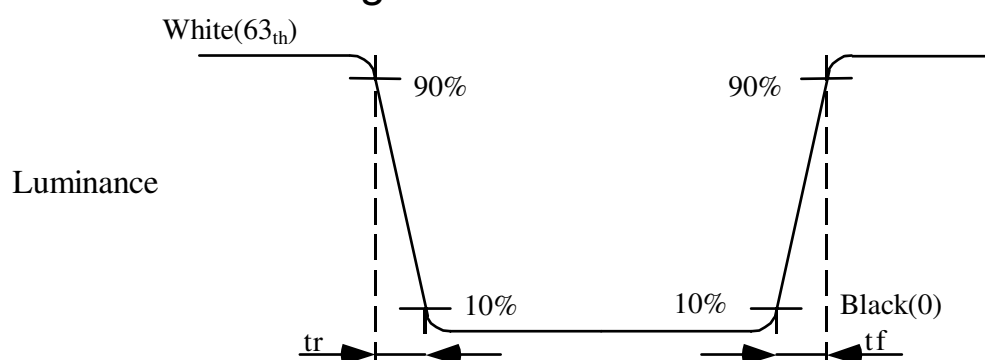

Fig.8-3 Definition of Response Time

8. RELIABILITY TEST

8.1 Temperature and Humidity

TEST ITEMS	CONDITIONS	REMARK
High Temperature Operation	70°C; 240hrs	
High Temperature High Humidity Operation	60°C; 90%RH; 240hrs	No condensation
High Temperature Storage	80°C; 240hrs	
Low Temperature Operation	-20°C; 240hrs	
Low Temperature Storage	-30°C; 240hrs	
Thermal Shock	-30°C (0.5hr) ~ 80°C (0.5hr); 200 Cycles	No operation

8.2 Shock and Vibration

ITEMS	CONDITIONS
Shock (Non-Operation)	<ul style="list-style-type: none"> ● Shock level: 980m/s²(equal to 100G). ● Waveform: half sinusoidal wave,6ms. ● Number of shocks: one shock input in each direction of three mutually perpendicular axes for a total of three shock inputs.
Vibration (Non-Operation)	<ul style="list-style-type: none"> ● Frequency range:8~33.3Hz ● Stoke : 1.3 mm ● Vibration: sinusoidal wave, perpendicular axis(both x, y,z axis: 2Hrs). ● Sweep: 2.9G,33.3 Hz -400 Hz ● Cycle: 15 min

8.3 Electrostatic Discharge

TEST ITEM	CONDITIONS	Note
ESD	150pF , 330Ω , ±8kV&±15kV air	(1)
	200pF , 0Ω , ±200V contact test	(2)

Measure point :

- (1) LCD glass and metal bezel
- (2) IF connector pins

8.4 Judgment Standard

The judgment of the above test should be made as follow:

Pass: Normal display image with no obvious non-uniformity and no line defect.

Partial transformation of the module parts should be ignored.

Fail: No display image, obvious non-uniformity, or line defects.