

## Series 275

# Granville-Phillips® Series 275 Mini-Convector® Vacuum Gauge Module with Nonlinear Analog Outputs and Process Control Relays



## Instruction Manual

*Instruction manual part number 275512*

*Revision 03 - June 2008*



## Series 275

# Granville-Phillips® Series 275 Mini-Convectron® Vacuum Gauge Module with Nonlinear Analog Outputs and Process Control Relays

This Instruction Manual is for use with all Granville-Phillips Series 275 Mini-Convectron Vacuum Gauge Modules With Nonlinear Analog Outputs and Process Control Relays. A list of applicable catalog numbers is provided on the following page.



To order products online, visit [www.brooks.com](http://www.brooks.com)

For customer service, 24 hours per day, 7 days per week, every day of the year including holidays, toll-free within the USA, phone 1-800-367-4887

For customer service within the USA, 8 AM to 5 PM weekdays excluding holidays:

- Toll-free phone: 1-800-776-6543
- Phone: 1-303-652-4400
- FAX: 1-303-652-2844
- Email: [co-csr@brooks.com](mailto:co-csr@brooks.com)
- Web: [www.brooks.com](http://www.brooks.com)

## Instruction Manual

© 2004-2008 Brooks Automation. All rights reserved.  
Granville-Phillips® and Convectron® are registered trademarks of Brooks Automation, Inc.  
All other trademarks and registered trademarks are the properties of their respective owners.

## Catalog numbers for Series 275 Mini-Convectron Modules (CE Marked)

With electrical connector. Operating power: 11.5 Vdc to 26.5 Vdc

### Mini-Convectron Module with one setpoint relay

1/8 NPT / 1/2 inch tubulation	275800-EU
1/4 inch VCR-type female fitting	275801-EU
1/2 inch VCR-type female fitting	275863-EU
3/8 inch VCO-type male fitting	275802-EU
1.33 inch (NW16CF) ConFlat-type flange	275803-EU
2.75 inch (NW35CF) ConFlat-type flange	275804-EU
NW16KF flange	275806-EU
NW25KF flange	275807-EU
NW40KF flange	275808-EU

### Mini-Convectron Module with two setpoint relays

1/8 NPT / 1/2 inch tubulation	275870-EU
1/4 inch VCR-type female fitting	275871-EU
1/2 inch VCR-type female fitting	275867-EU
3/8 inch VCO-type male fitting	275872-EU
1.33 inch (NW16CF) ConFlat-type flange	275873-EU
2.75 inch (NW35CF) ConFlat-type flange	275874-EU
NW16KF flange	275876-EU
NW25KF flange	275877-EU
NW40KF flange	275878-EU

### Mini-Convectron Module with two setpoint relays and 3-digit digital display

#### Display in Torr

1/8 NPT / 1/2 inch tubulation	275904-EU
1/4 inch VCR-type female fitting	275905-EU
1/2 inch VCR-type female fitting	275906-EU
3/8 inch VCO-type male fitting	275907-EU
1.33 inch (NW16CF) ConFlat-type flange	275908-EU
2.75 inch (NW35CF) ConFlat-type flange	275909-EU
NW16KF flange	275911-EU
NW25KF flange	275912-EU
NW40KF flange	275913-EU

#### Display in Pascal

1/8 NPT / 1/2 inch tubulation	275904-EU-P
1/4 inch VCR-type female fitting	275905-EU-P
1/2 inch VCR-type female fitting	275906-EU-P
3/8 inch VCO-type male fitting	275907-EU-P
1.33 inch (NW16CF) ConFlat-type flange	275908-EU-P
2.75 inch (NW35CF) ConFlat-type flange	275909-EU-P
NW16KF flange	275911-EU-P
NW25KF flange	275912-EU-P
NW40KF flange	275913-EU-P

# Table of Contents

<b>Chapter 1</b>	<b>Before You Begin</b> . . . . .	<b>7</b>
	1.1 About These Instructions . . . . .	7
	1.2 Customer Service . . . . .	7
	1.3 Caution and Warning Statements . . . . .	8
	1.4 System Grounding . . . . .	8
	1.5 . . . . . Implosion / Explosion	9
	1.6 Operation . . . . .	9
	1.7 Reading and Following Instructions . . . . .	10
<b>Chapter 2</b>	<b>Installation</b> . . . . .	<b>11</b>
	2.1 Module Components . . . . .	11
	2.2 Installing Pressure Relief Devices . . . . .	12
	2.3 Installation Procedure . . . . .	13
	Step 1 Locate and orient the module . . . . .	13
	Locate the Module . . . . .	13
	Orient the Module . . . . .	15
	Step 2 Attach the module to the vacuum chamber . . . . .	16
	1/8 NPT pipe thread . . . . .	16
	VCR type fitting . . . . .	16
	KF flange . . . . .	16
	ConFlat flange . . . . .	16
	Step 3 Assemble and connect the wiring . . . . .	17
	Connecting Cable . . . . .	17
	Wiring Terminals . . . . .	17
	Grounding . . . . .	18
	Step 4 Configure the setpoint relays for the application . . . . .	19
	Step 5 Calibrate the Convector gauge . . . . .	19
	Atmospheric Pressure Calibration . . . . .	19
	Vacuum Chamber Pressure Calibration . . . . .	19
<b>Chapter 3</b>	<b>Operation</b> . . . . .	<b>21</b>
	3.1 Preparing to Operate the Module . . . . .	21
	3.2 Nonlinear Analog Output . . . . .	26
	Commonly used Gases Other than N <sub>2</sub> or Air . . . . .	26
	Other Gases . . . . .	26
	3.3 Setpoint Relays . . . . .	34
	Preparing to Adjust Setpoint Relays . . . . .	35
	Adjusting Setpoint Relays . . . . .	36
	3.4 Reading Relay Status . . . . .	39
	3.5 Calibrating Convector Gauge at Atmospheric Pressure . . . . .	39
	3.6 Calibrating Convector Gauge at Vacuum Chamber Pressure . . . . .	41
	3.7 Modules Operating at Low Pressure . . . . .	41
	3.8 Factory Settings . . . . .	42

Chapter 4	Maintenance .....	43
	4.1 Customer Service .....	43
	Damage Requiring Service .....	43
	4.2 Troubleshooting .....	44
	Precautions .....	44
	Symptoms, Causes, and Solutions .....	45
	4.3 Convectron Gauge Test .....	46
	4.4 Convectron Gauge Removal and Replacement .....	47
	Removing the Convectron Gauge .....	47
	Replacing the Convectron Gauge .....	47
	4.5 Returning a Product for Repair .....	48
Appendix A	Specifications .....	49
Appendix B	Theory of Operation .....	53
Index .....		55

## 1.1 About These Instructions

These instructions explain how to install, operate, and maintain the Granville-Phillips® Mini-Convector® vacuum gauge module.

- *This chapter* explains caution and warning statements, which must be adhered to at all times; explains your responsibility for reading and following all instructions; defines the terms “module” and “Convector gauge”; and tells you how to contact customer service.
- *Chapter 2* explains how to install the module.
- *Chapter 3* explains how to operate the module, which has two programmable setpoint relays.
- *Chapter 4* explains troubleshooting, Convector gauge testing, removal and replacement, and module return procedures.
- *Appendix A* provides specifications for the module.
- *Appendix B* explains terminology and explains how the Convector convection-enhanced Pirani heat-loss gauge measures pressure.

**Table 1-1 Terms Describing the Mini-Convector Module and Components**

Term	Description
Module	The Mini-Convector vacuum gauge module, which contains a Convector convection-enhanced Pirani heat-loss pressure gauge.
Convector gauge	The Convector convection-enhanced Pirani heat-loss gauge, which measures pressure within the vacuum chamber

## 1.2 Customer Service

For customer service:

- Phone **1-303-652-4400** or **1-800-776-6543** within USA
- Phone **1-800-367-4887** 24 hours per day, 7 days per week within the USA
- Email [co-csr@brooks.com](mailto:co-csr@brooks.com)
- For Global Customer Support, go to [www.brooks.com](http://www.brooks.com), click on Contact Us, then click on Global Offices to locate the Brooks Automation office nearest you.

**1.3 Caution and Warning Statements**

This manual contains caution and warning statements with which you *must* comply to prevent inaccurate measurement, property damage, or personal injury.

 **CAUTION**

**Caution statements alert you to hazards or unsafe practices that could result in minor personal injury or property damage.**

Each caution statement explains what you *must* do to prevent or avoid the potential result of the specified hazard or unsafe practice.

 **WARNING**

**Warning statements alert you to hazards or unsafe practices that could result in severe property damage or personal injury due to electrical shock, fire, or explosion.**

Each warning statement explains what you *must* do to prevent or avoid the potential result of the specified hazard or unsafe practice.

Caution and warning statements comply with American Institute of Standards Z535.1–2002 through Z535.5–2002, which set forth voluntary practices regarding the content and appearance of safety signs, symbols, and labels.

Each caution or warning statement explains:

- a. The specific hazard that you *must* prevent or unsafe practice that you *must* avoid,
- b. The potential result of your failure to prevent the specified hazard or avoid the unsafe practice, and
- c. What you *must* do to prevent the specified hazardous result.

**1.4 System Grounding**

Grounding, though simple, is very important! Be certain that ground circuits are correctly used on your ion gauge power supplies, gauges, and vacuum chambers, regardless of their manufacturer. Safe operation of vacuum equipment, including the Mini-Convector Module, requires grounding of all exposed conductors of the gauges, the controller and the vacuum system. **LETHAL VOLTAGES** may be established under some operating conditions unless correct grounding is provided.



Ion producing equipment, such as ionization gauges, mass spectrometers, sputtering systems, etc., from many manufacturers may, under some conditions, provide sufficient electrical conduction via a plasma to couple a high voltage electrode potential to the vacuum chamber. If exposed conductive parts of the gauge, controller, and chamber are not properly grounded, they may attain a potential near that of the high voltage electrode during this coupling. Potential fatal electrical shock could then occur because of the high voltage between these exposed conductors and ground.

### **1.5 Implosion / Explosion**

Danger of injury to personnel and damage to equipment exists on all vacuum systems that incorporate gas sources or involve processes capable of pressuring the system above the limits it can safely withstand.

For example, danger of explosion in a vacuum system exists during backfilling from pressurized gas cylinders because many vacuum devices such as ionization gauge tubes, glass windows, glass belljars, etc., are not designed to be pressurized.

Do not attach cables to glass gauge pins while the gauge is under vacuum. Accidental bending of the pins may cause the glass to break and implode. Cables, once installed, should be secured to the system to provide strain relief for the gauge tube pins.

Install suitable devices that will limit the pressure from external gas sources to the level that the vacuum system can safely withstand. In addition, install suitable pressure relief valves or rupture disks that will release pressure at a level considerably below that pressure which the system can safely withstand.

Suppliers of pressure relief valves and pressure relief disks are listed in Thomas Register under "Valves, Relief", and "Discs, Rupture".

Confirm that these safety devices are properly installed before installing the the Mini-Convector Module. In addition, check that (1) the proper gas cylinders are installed, (2) gas cylinder valve positions are correct on manual systems, and (3) the automation is correct on automated systems.

### **1.6 Operation**

It is the installer's responsibility to ensure that the automatic signals provided by the process control module are always used in a safe manner.

Carefully check manual operation of the system and the setpoint programming before switching to automatic operation. Where an equipment malfunction could cause a hazardous situation, always provide for fail-safe operation. As an example, in an automatic backfill operation where a malfunction might cause high internal pressures, provide an appropriate pressure relief device.

**1.7 Reading and Following Instructions**

You must comply with all instructions while you are installing, operating, or maintaining the module. Failure to comply with the instructions violates standards of design, manufacture, and intended use of the module. Granville-Phillips and Brooks Automation disclaim all liability for the customer's failure to comply with the instructions.

- *Read instructions* – Read all instructions before installing or operating the product.
- *Follow instructions* – Follow all installation, operating and maintenance instructions.
- *Retain instructions* – Retain the instructions for future reference.
- *Heed warnings and cautions* – Adhere to all warnings and caution statements on the product and in these instructions.

*Parts and accessories* – Install only those replacement parts and accessories that are recommended by Brooks Automation, Inc./Granville-Phillips. Substitution of parts is hazardous.

## 2.1 Module Components

The Mini-Convector module contains a Convector convection-enhanced Pirani heat-loss gauge.

### WARNING

**Using the module to measure the pressure of flammable or explosive gases can cause a fire or explosion resulting in severe property damage or personal injury.**

Do not use the module to measure the pressure of flammable or explosive gases.

The module is shipped with an instrument screwdriver and a 15-pin female, high-density subminiature D connector that mates to the male connector on the module.

Figure 2-1 illustrates the module without the digital display. The module without the display may have one setpoint relay or two setpoint relays.

Figure 2-2 illustrates the module with the 3-digit digital display. The module with the display has two setpoint relays.

**Figure 2-1 Mini-Convector Module without Digital Display**



Mini-Convector module with one setpoint relay, no display



Mini-Convector module with two setpoint relays, no display

Figure 2-2 Mini-Convectron Module with two Setpoint Relays and 3-Digit Digital Display



## 2.2 Installing Pressure Relief Devices

Before you install the module, install appropriate pressure relief devices in the vacuum system.

Brooks Automation, Inc. does not supply pressure relief valves or rupture disks. Suppliers of pressure relief valves and rupture disks are listed in the *Thomas Register* under “Valves, Relief” and “Discs, Rupture.”

### CAUTION

**Operating the module above 1000 Torr (1333 mbar, 133 kPa) true pressure could cause pressure measurement error or product failure.**

To avoid measurement error or product failure due to overpressurization, install pressure relief valves or rupture disks in the system if pressure exceeds 1000 Torr (1333 mbar, 133 kPa).

**2.3 Installation Procedure**

The module installation procedure includes the following steps:

1. Locating and orienting the module.
2. Attaching the module vacuum chamber fitting to its mate on the vacuum chamber.
3. Assembling and connecting module wiring.
4. Configuring the setpoint relays to the desired voltage levels.
5. Calibrating the Convectron gauge at atmospheric and vacuum pressures.

**WARNING**

**Failure to use accurate pressure conversion data for N<sub>2</sub> or air to other gases can cause an explosion due to overpressurization.**

If the module will measure any gas other than N<sub>2</sub> or air, before putting the module into operation, adjust setpoint relays for the process gas that will be used.

**Step 1** *Locate and orient the module*

To locate and orient the module, refer to Figure 2-3, Figure 2-4, and Table 2-1, and follow the instructions below.

**Locate the Module**

- For greatest accuracy and repeatability, locate the module in a stable, room-temperature environment. Ambient temperature should never exceed 40 °C (104 °F) operating, non-condensing, or 85 °C (185 °F) non-operating.
- Locate the module away from internal and external heat sources and in an area where ambient temperature remains reasonably constant.
- Do not locate the module where it requires long lengths of tubing or has constricted tubing. Length of tubing depends on the application. Longer tubing will affect vacuum pressure limit and response time.
- Do not locate the module near the pump, where gauge pressure might be lower than normal vacuum chamber pressure.
- Do not locate the module near a gas inlet or other source of contamination, where inflow of gas or particulates causes atmospheric pressure to be higher than system atmosphere.
- Do not locate the module where it will be exposed to corrosive gases such as mercury vapor or fluorine.
- Do not locate the module where it will vibrate. Vibration causes convection cooling, resulting in inaccurate high pressure readings.

**Figure 2-3 Mini-Convectron Module Dimensions**

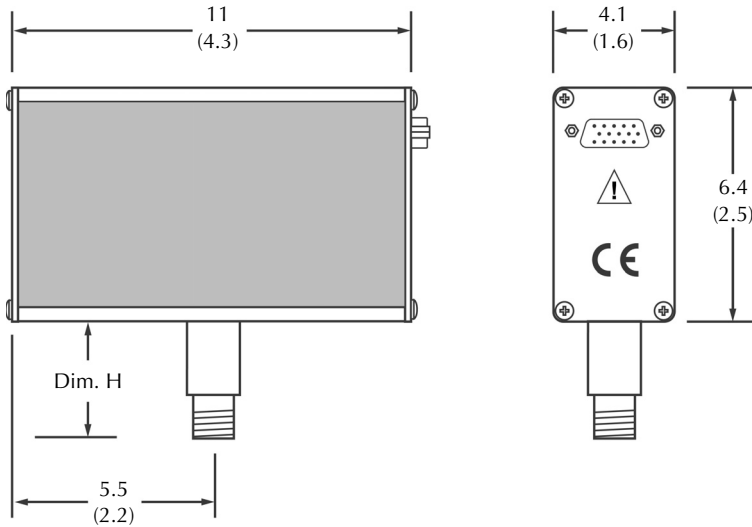

**Table 2-1 Mini-Convectron Vacuum Connections**

Vacuum Connections	Dim. H	
	cm	in.
1/8 NPT pipe thread, 1/2-inch inside diameter	2.2	0.9
1/2-inch 4 VCR® type fitting, female	3.0	1.2
1/2-inch 8 VCR type fitting, female	3.9	1.5
NW16KF flange	3.1	1.2
NW25KF flange	3.1	1.2
NW40KF flange	3.7	1.5
1.33-inch (NW16CF) ConFlat® flange	3.8	1.5
2.75-inch (NW35CF) ConFlat flange	3.8	1.5

**Orient the Module**

For proper operation of the module above 1 Torr, orient the module so the axis is horizontal (see Figure 2-4). Although the Convectron gauge will read correctly below 1 Torr with the module mounted in any position, inaccurate readings will result at pressures above 1 Torr if the module axis is not horizontal.

**Figure 2-4 Module Orientation**

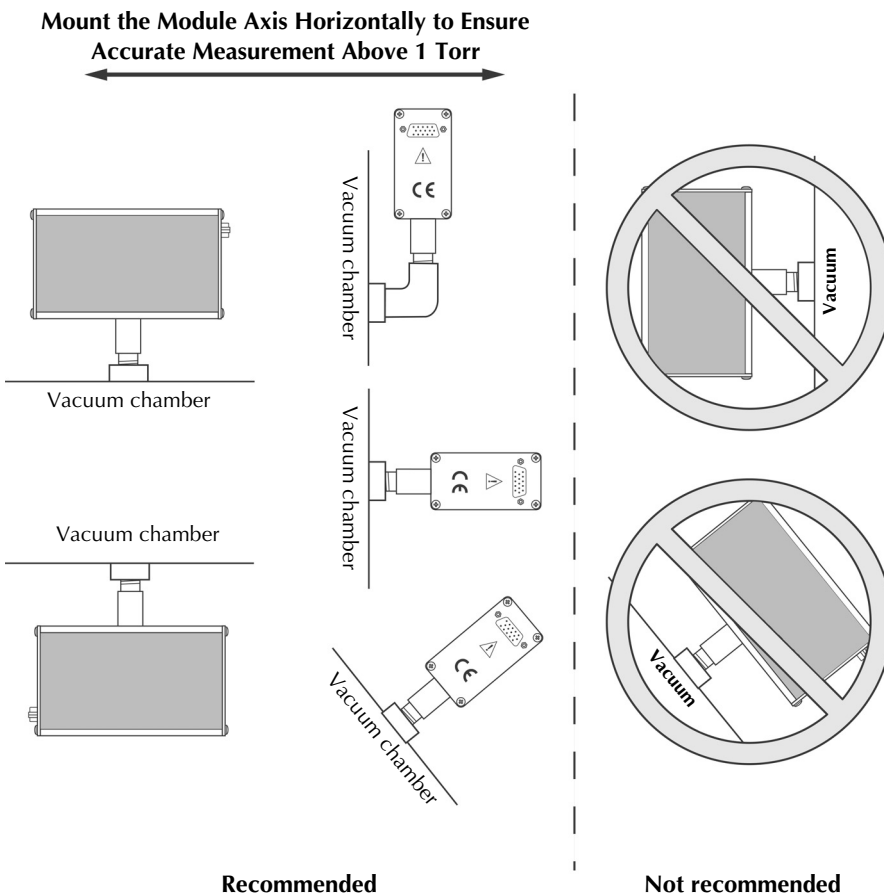

Installation

**Step 2**     *Attach the module to the vacuum chamber*

Attach the module vacuum chamber fitting to its mate on the vacuum chamber.

**⚠ CAUTION**

**Twisting the module to tighten the fitting to the vacuum chamber can damage the module's internal connections.**

- Do not twist the module to tighten the fitting.
- Use appropriate tools to tighten the fitting.

**1/8 NPT pipe thread**



The 1/8 NPT pipe thread accommodates a standard 1/8 NPT female fitting.

- a. Wrap the threads of the port to the vacuum chamber with Teflon® tape.
- b. Without using a wrench or other tool, tighten the module just enough to achieve a seal.

**VCR type fitting**

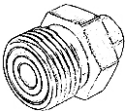

- a. Remove the plastic or metal bead protector cap from the fitting.
- b. If a gasket is used, place the gasket into the female nut.
- c. Assemble the components and tighten them to finger-tight.
- d. While holding a back-up wrench stationary, tighten the female nut 1/8 turn past finger-tight on 316 stainless steel or nickel gaskets, or 1/4 turn past finger-tight on copper or aluminum gaskets.

**KF flange**



The KF mounting system requires O-rings and centering rings between mating flanges.

- a. Tighten the clamp to compress the mating flanges together.
- b. Seal the O-ring.

**ConFlat flange**

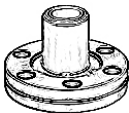

To minimize the possibility of leaks with ConFlat flanges, use high strength stainless steel bolts and a new, clean OFHC copper gasket. Avoid scratching the seal surfaces. To avoid contamination, install metal gaskets.

- a. Finger tighten all bolts.
- b. Use a wrench to continue tightening 1/8 turn at a time in crisscross order (1, 4, 2, 5, 3, 6) until flange faces make contact.
- c. Further tighten each bolt about 1/16 turn.



### Step 3 Assemble and connect the wiring

#### Connecting Cable

The cable is user-supplied. Brooks Automation does not supply the cable. Install externally shielded cable and connect the shield at both ends.

At the module end of the cable, connect the shield to the outer shell of the subminiature D connector.

On both versions of the module, connect the 11.5 to 26.5 Vdc power supply to terminals 3 and 4.

- Terminal 4 (ground) is negative (-).
- Terminal 3 (input) is positive (+).

For grounding instructions, see page 18.

#### Wiring Terminals

Figure 2-5 illustrates the 15-pin D subminiature wiring terminals for the module with two setpoint relays.

Figure 2-6 illustrates the 9-pin D subminiature wiring terminals for the module with one setpoint relay.

**Figure 2-5 15-Pin Connector for Module with two Setpoint Relays**

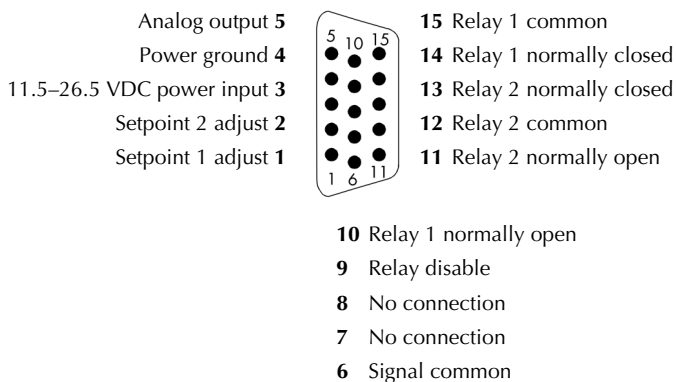

**Figure 2-6 9-Pin Connector for Module with one Setpoint Relay**

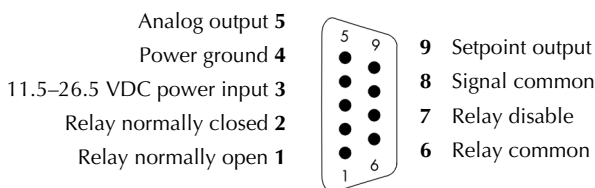

Grounding

**! WARNING**

**Improper grounding could cause product failure, property damage, or serious personal injury.**

To reduce the risk of product failure, property damage, or serious personal injury, follow ground network requirements for the facility.

- Maintain all exposed conductors at earth ground.
- Ground the module housing to the vacuum chamber as instructed below.
- Make sure the vacuum port to which the module is mounted is properly grounded.

If the fitting allows continuous metal-to-metal contact between the housing base and the vacuum chamber, the module is properly grounded via the fitting. If the fitting requires a rubber gasket, rubber O-ring, Teflon tape, or other material that prevents metal-to-metal contact between the housing base and the vacuum chamber, refer to Figure 2-7 and follow these instructions to ground the module to the vacuum chamber:

- Attach a metal hose clamp or other metal clamp to the gauge stem of the housing.
- Install a 3.31 mm<sup>2</sup> (12 AWG) or larger copper wire between the clamp and a metal ground lug, bolt, or stud on the vacuum chamber.

**Figure 2-7 Ground Connection to the Vacuum Chamber**

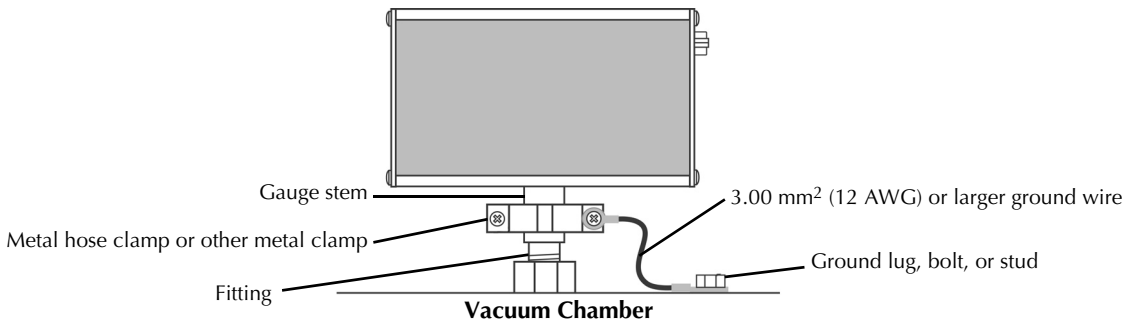

**Step 4** *Configure the setpoint relays for the application*

To configure setpoint relays for the module, see pages 34–38.

If the module will measure the pressure of a gas other than N<sub>2</sub> or air, you *must* adjust relay setpoints for the process gas. The true pressure of a gas other than N<sub>2</sub> or air may be substantially different from the pressure that the output indicates. For example, outputs might indicate a pressure of 10 Torr (1.33 kPa, 13.3 mbar) for argon, although the true pressure of the argon is 250 Torr (33.3 kPa, 333.3 mbar). Such a substantial difference between indicated pressure and true pressure can cause overpressurization resulting in an explosion.

**WARNING**

**Failure to use accurate pressure conversion data for N<sub>2</sub> or air to other gases can cause an explosion due to overpressurization.**

If the module will measure any gas other than N<sub>2</sub> or air, before connecting relays to system control devices, adjust setpoints for the process gas that will be used.

**Step 5** *Calibrate the Convectron gauge*

Calibration improves the accuracy and repeatability of the Convectron gauge. To calibrate the Convectron gauge, see pages 39–41.

**Atmospheric Pressure Calibration**

An atmospheric calibration is performed on the Convectron gauge, using N<sub>2</sub>, at the factory before the module is shipped. The factory calibration sets the atmospheric calibration point to 760 Torr (101.3 kPa, 1013 mbar) of N<sub>2</sub>.

Because performance varies depending on the process gas, you may wish to reset the atmospheric calibration point if a gas other than N<sub>2</sub> or air is being used. Periodic resets of the atmospheric calibration point also improve the accuracy and repeatability of the Convectron gauge near atmospheric pressure, even if the process gas is N<sub>2</sub> or air.

**Vacuum Chamber Pressure Calibration**

Periodic resets of the vacuum chamber pressure calibration point improve the accuracy and repeatability of the Convectron gauge.



### 3.1 Preparing to Operate the Module



#### WARNING

**Using the module to measure the pressure of flammable or explosive gases can cause a fire or explosion resulting in severe property damage or personal injury.**

Do not use the module to measure the pressure of flammable or explosive gases.

This chapter explains how to operate the Mini-Convectron module with a non-linear analog output and one setpoint relay or two setpoint relays. If the module has two setpoint relays, it may also have an optional pressure value display.

- Figure 3-1 illustrates the module with two setpoint relays and the optional display. Table 3-1 lists features of the front panel if the module has the optional display.
- Figure 3-2 illustrates the module with one setpoint relay and no display. Table 3-2 lists features of the front panel if the module has one setpoint relay and no display.
- Figure 3-3 illustrates the module with two setpoint relays and no display. Table 3-3 lists features of the front panel if the module has two setpoint relays and no display.

**Figure 3-1 Mini-Convectron Module with two Setpoint Relays and 3-Digit Display**

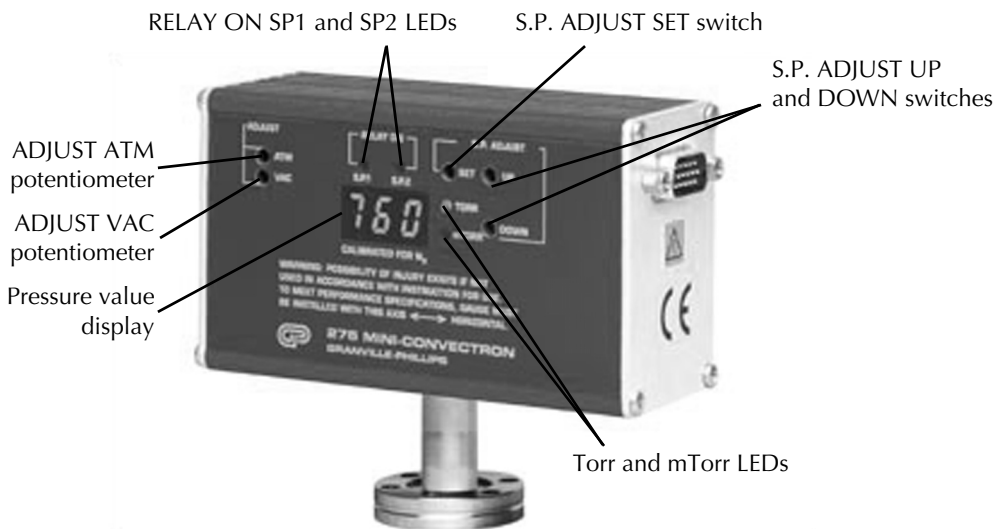

**Table 3-1 Front Panel Features of Mini-Convectron Module with 3-Digit Display**

Feature	Description
ADJUST ATM potentiometer	Enables Convectron gauge calibration at atmospheric pressure
ADJUST VAC potentiometer	Enables Convectron gauge calibration at vacuum chamber pressure
S.P. ADJUST SET switch	Enables choosing of setpoint relay 1 or setpoint relay 2 for adjustment <ul style="list-style-type: none"> <li>• Press the switch once to adjust setpoint relay 1</li> <li>• Press the switch twice to adjust setpoint relay 2</li> </ul>
S.P. ADJUST DOWN switch	Enables downward adjustment of setpoint 1 or setpoint 2
S.P. ADJUST UP switch	Enables upward adjustment of setpoint 1 or setpoint 2
Pressure value display	Provides 3-digit indication of measured pressure
TORR and mTORR LEDs	<ul style="list-style-type: none"> <li>• TORR is solid green when 3-digit display indicates pressure in Torr</li> <li>• mTORR is solid green when 3-digit display indicates pressure in mTorr</li> </ul>
RELAY ON SP1 and RELAY ON SP2 LEDs	<ul style="list-style-type: none"> <li>• RELAY ON SP1 is solid green when setpoint relay 1 is activated</li> <li>• RELAY ON SP1 blinks green if S.P. ADJUST SET switch has been pressed once</li> <li>• RELAY ON SP2 is solid green when setpoint relay 2 is activated</li> <li>• RELAY ON SP2 blinks green if S.P. ADJUST SET switch has been pressed twice</li> </ul>

**Figure 3-2 Mini-Convectron Module with one Setpoint Relay, no Display**

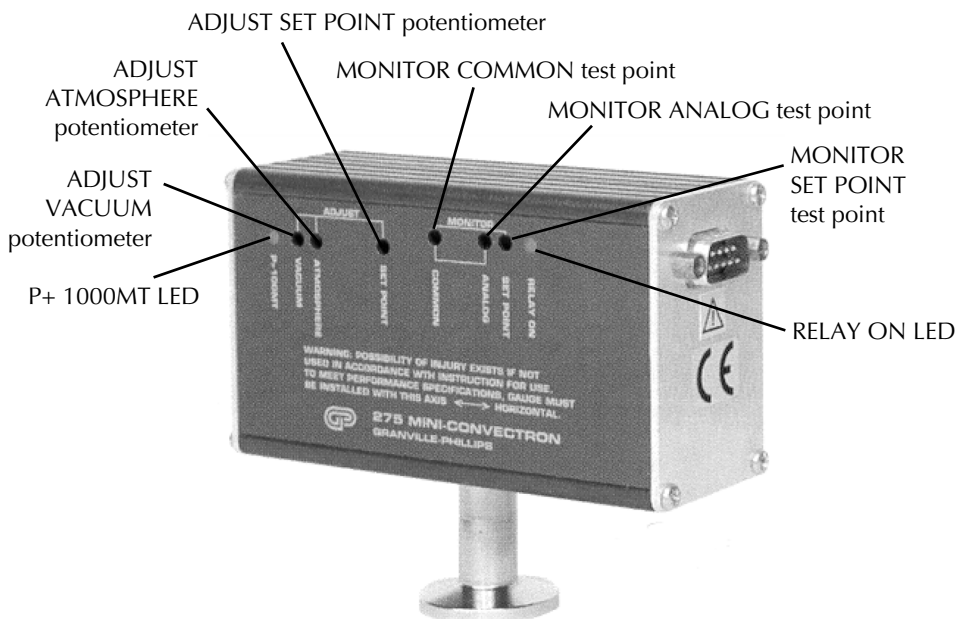

**Table 3-2 Front Panel Features of Mini-Convectron Module with one Setpoint Relay, no Display**

Feature	Description
ADJUST ATMOSPHERE potentiometer	Enables Convectron gauge calibration at atmospheric pressure
ADJUST VACUUM potentiometer	Enables Convectron gauge calibration at vacuum chamber pressure
ADJUST SET POINT potentiometer	Enables setting of vacuum pressure at which setpoint relay activates
MONITOR ANALOG test point	Enables reading of analog output voltage representing measured pressure
MONITOR COMMON test point	Enable checking of values for: <ul style="list-style-type: none"> <li>Convectron gauge calibration at atmospheric pressure</li> <li>Convectron gauge calibration at vacuum chamber pressure</li> </ul>
MONITOR SET POINT test point	Enables checking of setpoint relay voltage representing measured pressure
P+1000MT LED	Turns solid red when pressure is > 1000 mTorr
RELAY ON LED	Turns solid green when setpoint relay is activated

**Figure 3-3 Mini-Convectron Module with two Setpoint Relays, no Display**

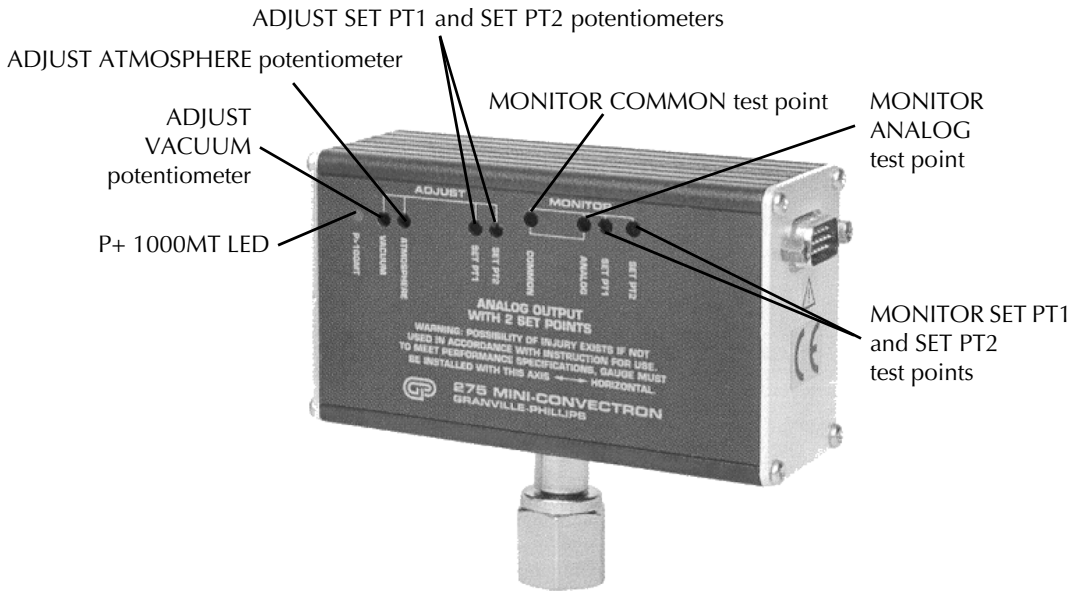

**Table 3-3 Front Panel Features of Mini-Convectron Module with two Setpoint Relays, no Display**

Feature	Description
ADJUST ATMOSPHERE potentiometer	Enables Convectron gauge calibration at atmospheric pressure
ADJUST VACUUM potentiometer	Enables Convectron gauge calibration at vacuum chamber pressure
ADJUST SET PT1 and ADJUST SET PT2 potentiometers	Enables setting of vacuum pressure at which setpoint relays activate
MONITOR ANALOG test point	Enables reading of analog output voltage representing measured pressure
MONITOR COMMON test point	Enable checking of values for: <ul style="list-style-type: none"> <li>Convectron gauge calibration at atmospheric pressure</li> <li>Convectron gauge calibration at vacuum chamber pressure</li> </ul>
MONITOR SET PT1 and MONITOR SET PT2 test points	Enables checking of setpoint relay voltage representing measured pressure
P+1000MT LED	Turns solid red when pressure is > 1000 mTorr



Before putting the module into operation, you must perform the following procedures:

1. Install the module in accordance with the instructions on pages 13-19.
2. Develop a logic diagram of the process control function.
3. Use Table 3-4 to record the proposed setpoint in volts, corresponding pressure setting, and activation direction for each relay.

**Table 3-4 Proposed Relay Setpoints**

Relay	Setpoint (V)	Pressure Corresponding to Setpoint
Relay 1		
Relay 2		

4. Draw a circuit schematic that specifies exactly how each piece of system hardware will connect to the module relays.
5. Attach a copy of the process control circuit diagram to this manual for future reference and troubleshooting.
6. If the module will measure the pressure of a gas other than N<sub>2</sub> or air, you *must* adjust the setpoint relays for the process gas that will be used. See pages 34–38.

If you need application assistance, phone a Brooks Automation/Granville-Phillips application engineer at **1-303-652-4400** or **1-800-776-6543** within USA, or mail [co-csr@brooks.com](mailto:co-csr@brooks.com).

Once the module is operating, you may use the module front panel to perform the tasks listed in Table 3-5.

**Table 3-5 Tasks and Page References for Module Operation**

Task	For instructions, see this page
Reading the analog output	See pages 26–29
Programming relay setpoints	See pages 34–38
Reading activation or deactivation status of relays	See page 39
Calibrating Convectron gauge at atmospheric pressure	See page 39
Calibrating Convectron gauge at vacuum chamber pressure	See page 41
Resetting parameters to factory defaults	See page 42

**3.2 Nonlinear Analog Output**

The module contains a convection-enhanced Pirani thermal conductivity gauge. The gauge measures the heat loss from a heated sensing wire that is maintained at a constant temperature.

The analog output produces a nonlinear voltage that corresponds to measured pressure. Output voltage is measured across pins 5 and 8 if the module has one setpoint relay or across pins 5 and 6 if the module has two setpoint relays.

Refer to Table 3-6 on page 27 to calculate pressure (y) as a function of output voltage (x). Figure 3-4 and Figure 3-5 on pages 28–29 are graphs that represent true pressure for N<sub>2</sub> or air (y axis) versus voltage (x axis).

- Output impedance is 100 Ω.
- The output is normalized to 0.375 Vdc at vacuum chamber pressure and to 5.534 Vdc at 1000 Torr (133.3 kPa, 1333 mbar) for N<sub>2</sub> or air.

The vacuum chamber pressure indicated by the gauge depends on the gas type, gas density (pressure), and the module orientation. The module is factory calibrated for N<sub>2</sub> (air has approximately the same calibration). For gases other than N<sub>2</sub> or air, heat loss varies at any given pressure, and you must apply an appropriate conversion factor.

**Commonly used Gases Other than N<sub>2</sub> or Air**

Refer to Table 3-7 on page 30 for pressure versus output voltage for 10 commonly used process gases other than N<sub>2</sub> or air.

Refer to Figure 3-6, Figure 3-7, or Figure 3-8 to determine true pressure versus indicated pressure for the gas that is being used.

**Other Gases**

If the gas being used is not included in Table 3-7, or for a gas mixture, you will need to generate a calibration curve using a gas-independent transfer standard such as a capacitance manometer. Use the following equation to determine the maximum usable output voltage:

$$\text{Output voltage} = \text{Input voltage} - 4 \text{ Vdc}$$

**Table 3-6 Equations for Calculating N<sub>2</sub> or Air Pressure Versus Analog Output Voltage**

Segment	Output Voltage	Equation where y = Pressure and x = Voltage	Coefficients	
1	0.375 to 2.842 V	$y_{\text{Torr}} = a + bx + cx^2 + dx^3 + ex^4 + fx^5$ $y_{\text{Pa}} = (a + bx + cx^2 + dx^3 + ex^4 + fx^5) \times 133.3$ $y_{\text{mbar}} = (a + bx + cx^2 + dx^3 + ex^4 + fx^5) \times 1.333$	a	-0.02585
			b	0.03767
			c	0.04563
			d	0.1151
			e	-0.04158
			f	0.008737
2	2.842 to 4.945 V	$y_{\text{Torr}} = \frac{a + cx + ex^2}{1 + bx + dx^2 + fx^3}$ $y_{\text{Pa}} = \left( \frac{a + cx + ex^2}{1 + bx + dx^2 + fx^3} \right) \times 133.3$ $y_{\text{mbar}} = \left( \frac{a + cx + ex^2}{1 + bx + dx^2 + fx^3} \right) \times 1.333$	a	0.1031
			b	-0.3986
			c	-0.02322
			d	0.07438
			e	0.07229
			f	-0.006866
3	4.94 to 5.659 V	$y_{\text{Torr}} = \frac{a + cx}{1 + bx + dx^2}$ $y_{\text{Pa}} = \left( \frac{a + cx}{1 + bx + dx^2} \right) \times 133.3$ $y_{\text{mbar}} = \left( \frac{a + cx}{1 + bx + dx^2} \right) \times 1.333$	a	100.624
			b	-0.37679
			c	-20.5623
			d	0.0348656

**Figure 3-4 Analog Output Voltage vs. Indicated N<sub>2</sub> or Air Pressure, 1 mTorr to 100 mTorr**

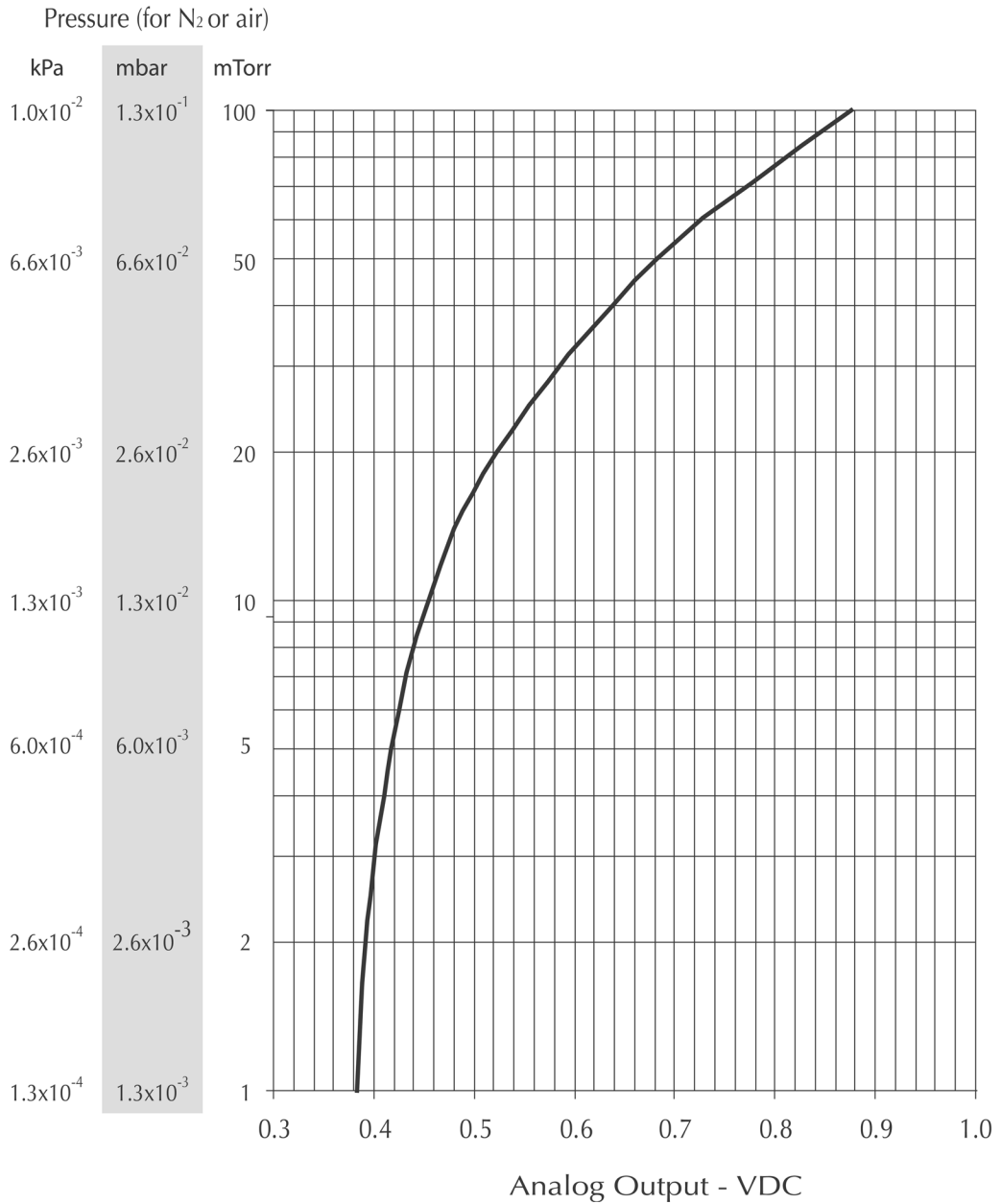

**Figure 3-5 Analog Output Voltage vs. Indicated N<sub>2</sub> or Air Pressure, 0.1 Torr to 1000 Torr**

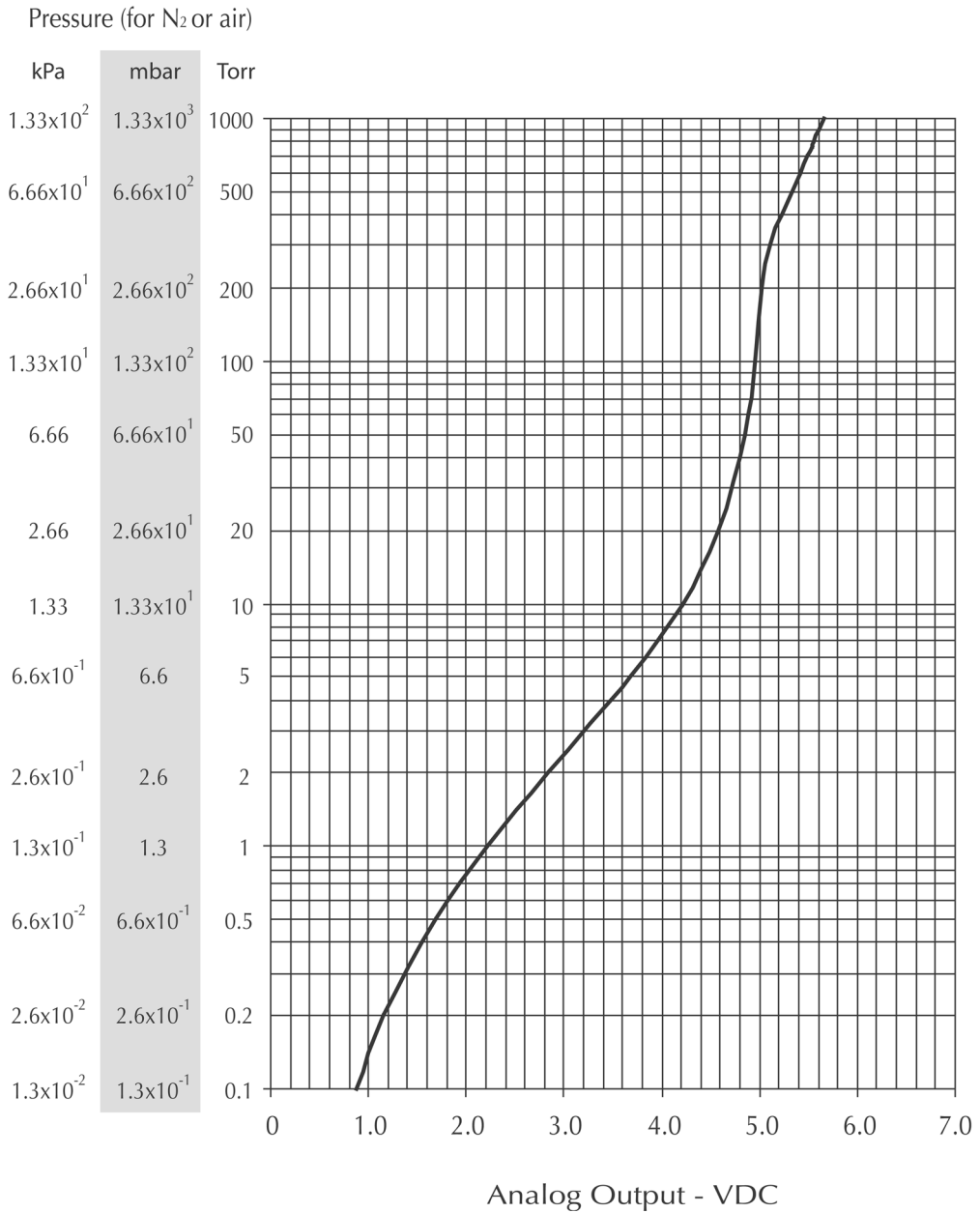

Operation

**Table 3-7 Voltages (Vdc) for Commonly used Gases, 0.1 mTorr to 1000 Torr**

Torr or mTorr	True pressure		N <sub>2</sub> (air)	Argon	Helium	O <sub>2</sub>	CO <sub>2</sub>	KR	Freon <sub>1,2</sub>	Freon <sub>22</sub>	D <sub>2</sub>	Ne	CH <sub>4</sub>
	kPa	mbar											
1 mTorr	1.3 x 10 <sup>-4</sup>	1.3 x 10 <sup>-3</sup>	.384	.381	.382	.384	.385	.379	.388	.388	.386	.381	.3896
2 mTorr	2.6 x 10 <sup>-4</sup>	2.6 x 10 <sup>-3</sup>	.392	.387	.389	.392	.395	.384	.401	.400	.396	.388	.403
5 mTorr	6.0 x 10 <sup>-4</sup>	6.0 x 10 <sup>-3</sup>	.417	.403	.409	.417	.412	.395	.437	.432	.425	.405	.438
10 mTorr	1.3 x 10 <sup>-3</sup>	1.3 x 10 <sup>-2</sup>	.455	.429	.441	.453	.462	.415	.488	.480	.470	.433	.492
20 mTorr	2.6 x 10 <sup>-3</sup>	2.6 x 10 <sup>-2</sup>	.523	.477	.497	.521	.536	.451	.581	.566	.549	.484	.584
50 mTorr	6.6 x 10 <sup>-3</sup>	6.6 x 10 <sup>-2</sup>	.682	.595	.637	.679	.705	.544	.778	.764	.727	.608	.796
100 mTorr	1.3 x 10 <sup>-2</sup>	1.3 x 10 <sup>-1</sup>	.876	.745	.814	.868	.900	.668	1.009	.990	.944	.768	1.053
0.2 Torr	2.6 x 10 <sup>-2</sup>	2.6 x 10 <sup>-1</sup>	1.155	.962	1.068	1.141	1.179	.847	1.315	1.291	1.265	1.002	1.392
0.5 Torr	6.6 x 10 <sup>-2</sup>	6.6 x 10 <sup>-1</sup>	1.683	1.386	1.589	1.664	1.668	1.194	1.826	1.805	1.914	1.469	2.014
1 Torr	1.3 x 10 <sup>-1</sup>	1.3	2.217	1.818	2.164	2.195	2.172	1.536	2.257	2.247	2.603	1.976	2.632
2 Torr	2.6 x 10 <sup>-1</sup>	2.6	2.842	2.333	2.939	2.814	2.695	1.921	2.647	2.666	3.508	2.631	3.313
5 Torr	6.6 x 10 <sup>-1</sup>	6.6	3.675	3.028	4.387	3.672	3.316	2.429	3.029	3.090	5.059	3.715	-
10 Torr	1.33	1.33 x 10 <sup>1</sup>	4.206	3.480	5.774	4.225	3.670	2.734	3.204	3.330	6.361	4.605	4.699
20 Torr	2.66	2.66 x 10 <sup>1</sup>	4.577	3.801	7.314	4.620	3.903	2.966	3.308	3.414	-	5.406	5.172
50 Torr	6.66	6.66 x 10 <sup>1</sup>	4.846	4.037	-	4.916	4.071	3.075	3.430	3.509	-	6.159	5.583
100 Torr	1.33 x 10 <sup>1</sup>	1.33 x 10 <sup>2</sup>	4.945	4.122	-	5.026	4.154	3.134	3.618	3.660	-	6.483	5.720
200 Torr	2.66 x 10 <sup>1</sup>	2.66 x 10 <sup>2</sup>	5.019	4.192	-	5.106	4.336	3.269	3.827	3.883	-	6.661	5.860
300 Torr	3.99 x 10 <sup>1</sup>	3.99 x 10 <sup>2</sup>	5.111	4.283	-	5.200	4.502	3.384	3.938	4.005	-	6.726	-
400 Torr	5.33 x 10 <sup>1</sup>	5.33 x 10 <sup>2</sup>	5.224	4.386	-	5.315	4.621	3.466	4.016	4.088	-	6.767	6.103
500 Torr	6.66 x 10 <sup>1</sup>	6.66 x 10 <sup>2</sup>	5.329	4.477	-	5.422	4.708	3.526	4.076	4.151	-	6.803	-
600 Torr	7.99 x 10 <sup>1</sup>	7.99 x 10 <sup>2</sup>	5.419	4.550	-	5.515	4.775	3.573	4.124	4.203	-	6.843	6.342
700 Torr	9.33 x 10 <sup>1</sup>	9.33 x 10 <sup>2</sup>	5.495	4.611	-	5.592	4.830	3.613	4.166	4.247	-	6.890	-
760 Torr	1.01 x 10 <sup>2</sup>	1.01 x 10 <sup>3</sup>	5.534	4.643	-	5.633	4.860	3.632	4.190	4.271	-	6.920	-
800 Torr	1.06 x 10 <sup>2</sup>	1.06 x 10 <sup>3</sup>	5.558	4.663	-	5.658	4.877	3.645	4.203	4.286	-	6.942	6.519
900 Torr	1.19 x 10 <sup>2</sup>	1.19 x 10 <sup>3</sup>	5.614	4.706	-	5.713	4.919	3.674	4.237	4.321	-	7.000	-
1000 Torr	1.33 x 10 <sup>2</sup>	1.33 x 10 <sup>3</sup>	5.659	4.745	-	5.762	4.955	-	4.270	4.354	-	7.056	6.642

Figure 3-6 True Pressure versus Indicated Pressure for Commonly used Gases,  $10^{-4}$  to  $10^{-1}$  Torr

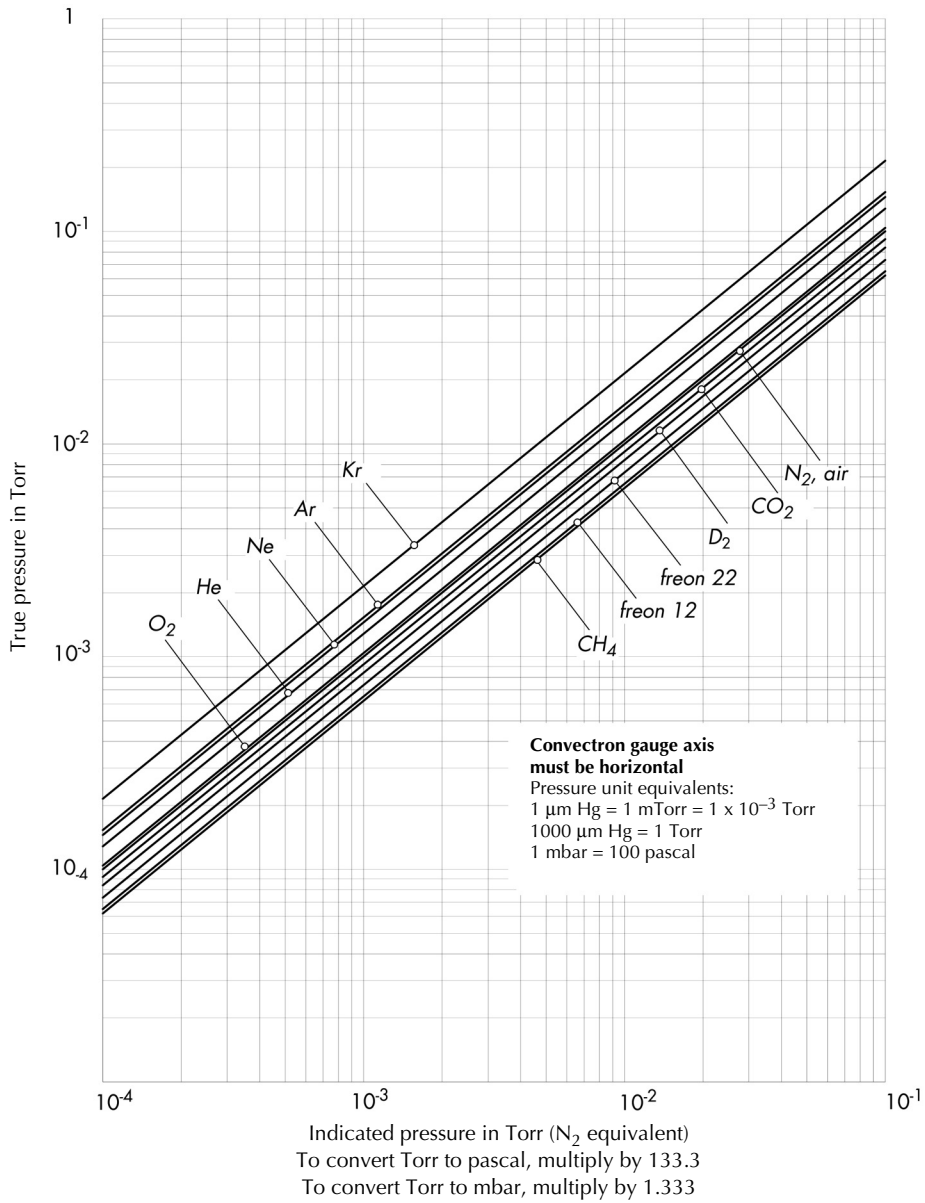

Operation

Figure 3-7 True Pressure versus Indicated Pressure for Commonly used Gases,  $10^{-1}$  to 1000 Torr

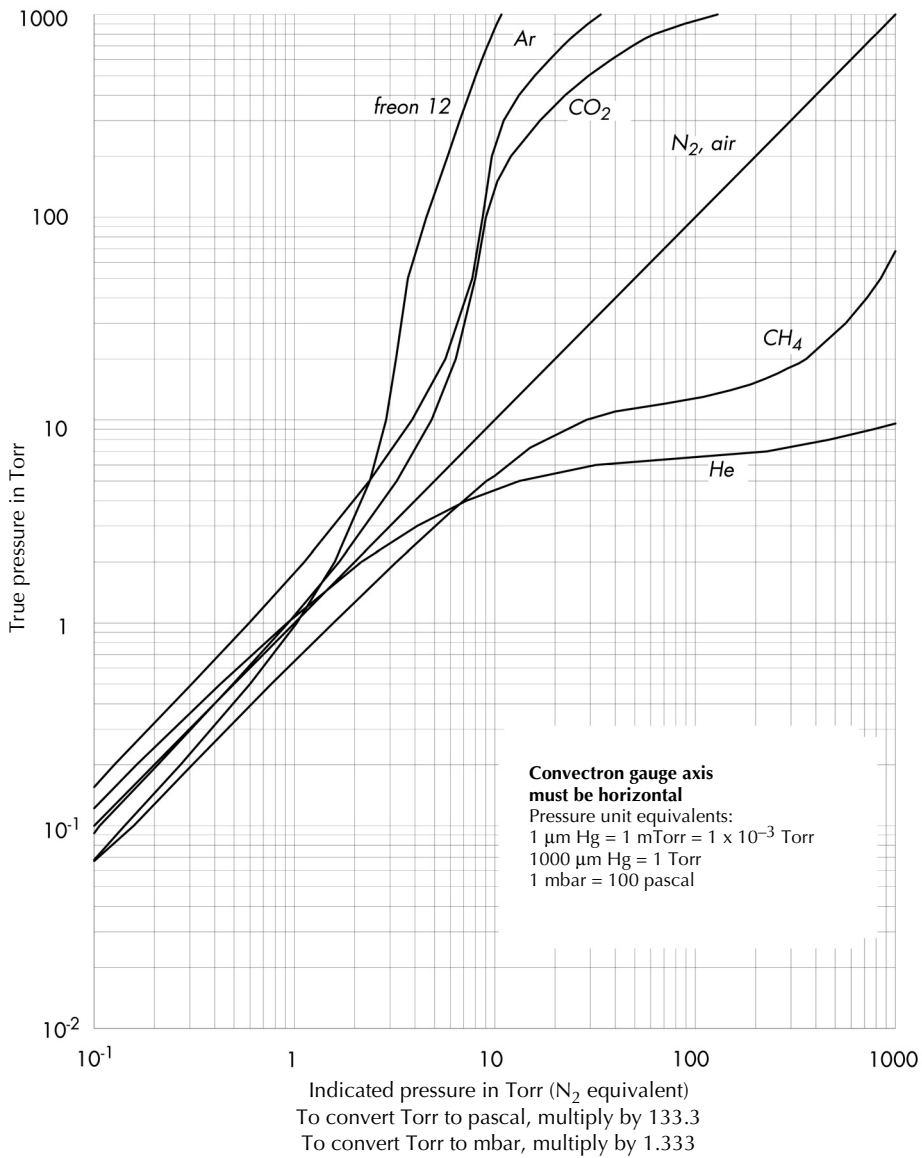
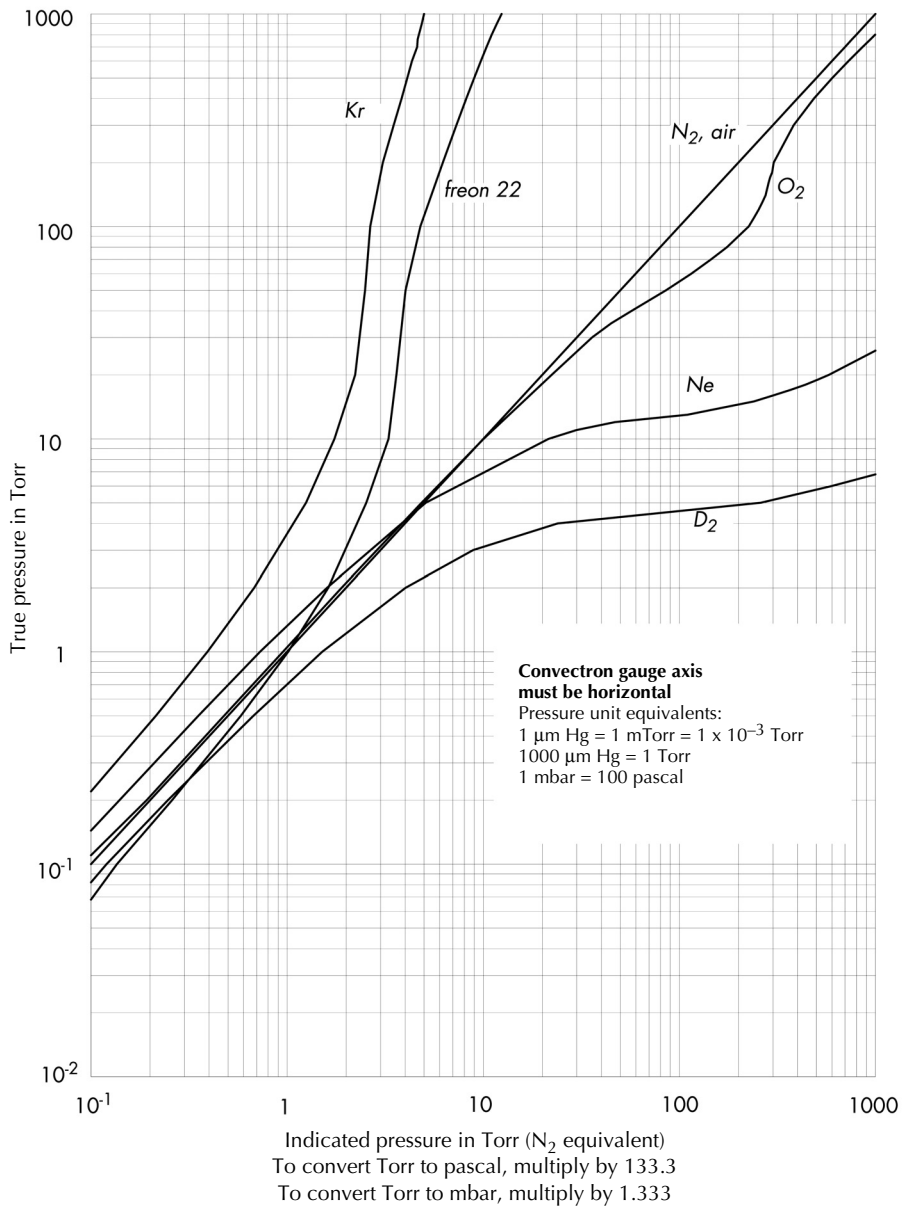



Figure 3-8 True Pressure versus Indicated Pressure for Commonly used Gases,  $10^{-1}$  to 1000 Torr



Operation

### 3.3 Setpoint Relays

The module includes one single-pole, double throw (SPDT) relay or two such relays. Each relay has a programmable setpoint. The setpoint is a voltage level that corresponds to a specified pressure at which the relay activates and deactivates.

When the module is shipped from the factory, relays are set to activate below 0.0 Torr. The relays will not operate until they have been adjusted for the application.

Adjustment causes setpoint relays to activate with decreasing pressure and deactivate at a higher pressure than the activation pressure, as illustrated in Figure 3-9.

Figure 3-9 Setpoint Relay Behavior

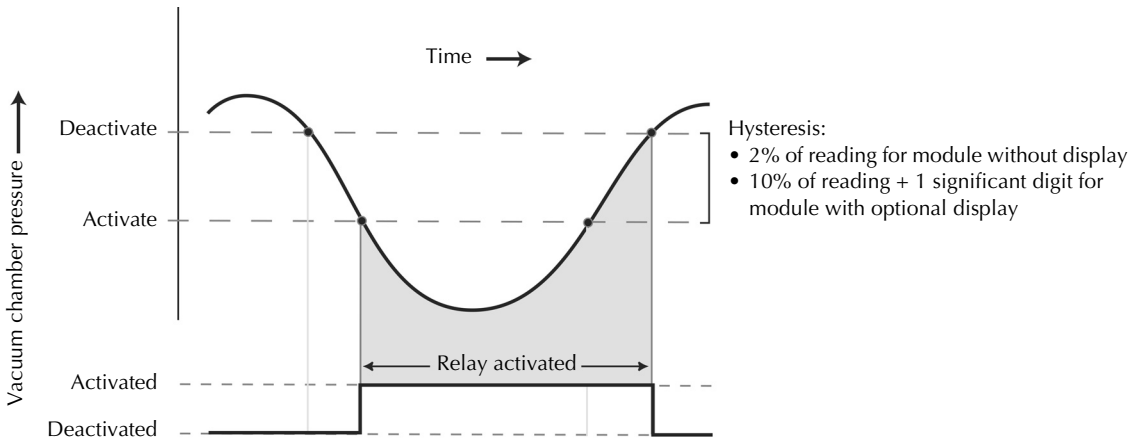

## Preparing to Adjust Setpoint Relays

If the module will measure the pressure of any process gas other than N<sub>2</sub> or air, you must adjust setpoint relays for the process gas that will be used.

The true pressure of a gas other than N<sub>2</sub> or air may be substantially different from the pressure that the output indicates. For example, outputs might indicate a pressure of 10 Torr for argon, although the true pressure of the argon is 250 Torr. Such a substantial difference between indicated pressure and true pressure can cause overpressurization resulting in an explosion.



### WARNING

**Failure to use accurate pressure conversion data for N<sub>2</sub> or air to other gases can cause an explosion due to overpressurization.**

If the module will measure any gas other than N<sub>2</sub> or air, before connecting relays to system control devices, adjust setpoints for the process gas that will be used.

Table 3-7 on page 30 and Figure 3-10 and Figure 3-11 on pages 37–38 enable you to determine the amount of voltage that corresponds to a specific N<sub>2</sub> or air pressure.

1. Make sure the module is properly installed, the axis is horizontal (see page 15), and the power supply is ON.
2. Figure 3-10 and Figure 3-11 are graphs that show test point voltage versus pressure for N<sub>2</sub> or air. Table 3-7 on page 30 lists test point voltage versus pressure for 12 commonly used process gases, including N<sub>2</sub> and air.

If you are using Figure 3-10 or Figure 3-11, find the point at which the horizontal line representing the desired trip point for N<sub>2</sub> or air pressure intercepts the vertical line representing test point voltage. For example:

- in Figure 3-10, a test point voltage of 0.64 V represents an N<sub>2</sub> or air pressure of 40 mTorr ( $5.3 \times 10^{-3}$  kPa,  $5.3 \times 10^{-2}$  mbar).
- In Figure 3-11, a test point voltage of 4.8 V indicates an N<sub>2</sub> or air pressure of 40 Torr (5.33 kPa, 53.3 mbar).

If the gas being used is not included in Table 3-7, or for a gas mixture, you will need to generate a calibration curve using a gas-independent transfer standard such as a capacitance manometer.

A built-in hysteresis prevents oscillation around the setpoint.

- For the module without a display, hysteresis is 2% of reading.
- For the module with the optional display, hysteresis is 10% of reading plus one significant digit.

Hysteresis depends on the vacuum chamber pressure at which the setpoint has been established and on whether or not the module has the optional display.

### **Adjusting Setpoint Relays**

The procedure for adjusting relays depends on the number of relays and on whether or not the module has the optional display.

#### ***If the module without a display has one setpoint relay:***

1. Use a high-precision, high-input impedance DVM to measure the voltage across the MONITOR SET POINT and MONITOR COMMON test points on the module front panel.
2. Use a flat-head instrument screwdriver to adjust the ADJUST SET POINT potentiometer for the desired setpoint voltage at which the relay will activate with decreasing pressure.

#### ***If the module without a display has two setpoint relays:***

1. Use a high-precision, high-input impedance DVM to measure the voltage across the MONITOR SET PT1 or MONITOR SET PT2 and MONITOR COMMON test points on the module front panel.
2. Use a flat-head instrument screwdriver to adjust the ADJUST SET PT1 or ADJUST SET PT2 potentiometer for the desired setpoint voltage at which relay 1 will activate with decreasing pressure.

#### ***If the module has a digital display:***

1. Press the S.P. ADJUST SET switch once to adjust setpoint relay 1 or twice to adjust setpoint relay 2.
  - If relay 1 will be adjusted, the RELAY ON SP1 LED blinks green.
  - If relay 2 will be adjusted, the RELAY ON SP2 LED blinks green.
2. *Within three seconds*, press the S.P. ADJUST UP or S.P. ADJUST DOWN switch until the display indicates the pressure, in Torr or mTorr, at which the relay should activate with decreasing pressure.

**Figure 3-10 Example Test Point Voltage: 0.64 V equals 40 mTorr ( $5.3 \times 10^{-3}$  kPa,  $5.3 \times 10^{-2}$  mbar) of N<sub>2</sub> or Air**

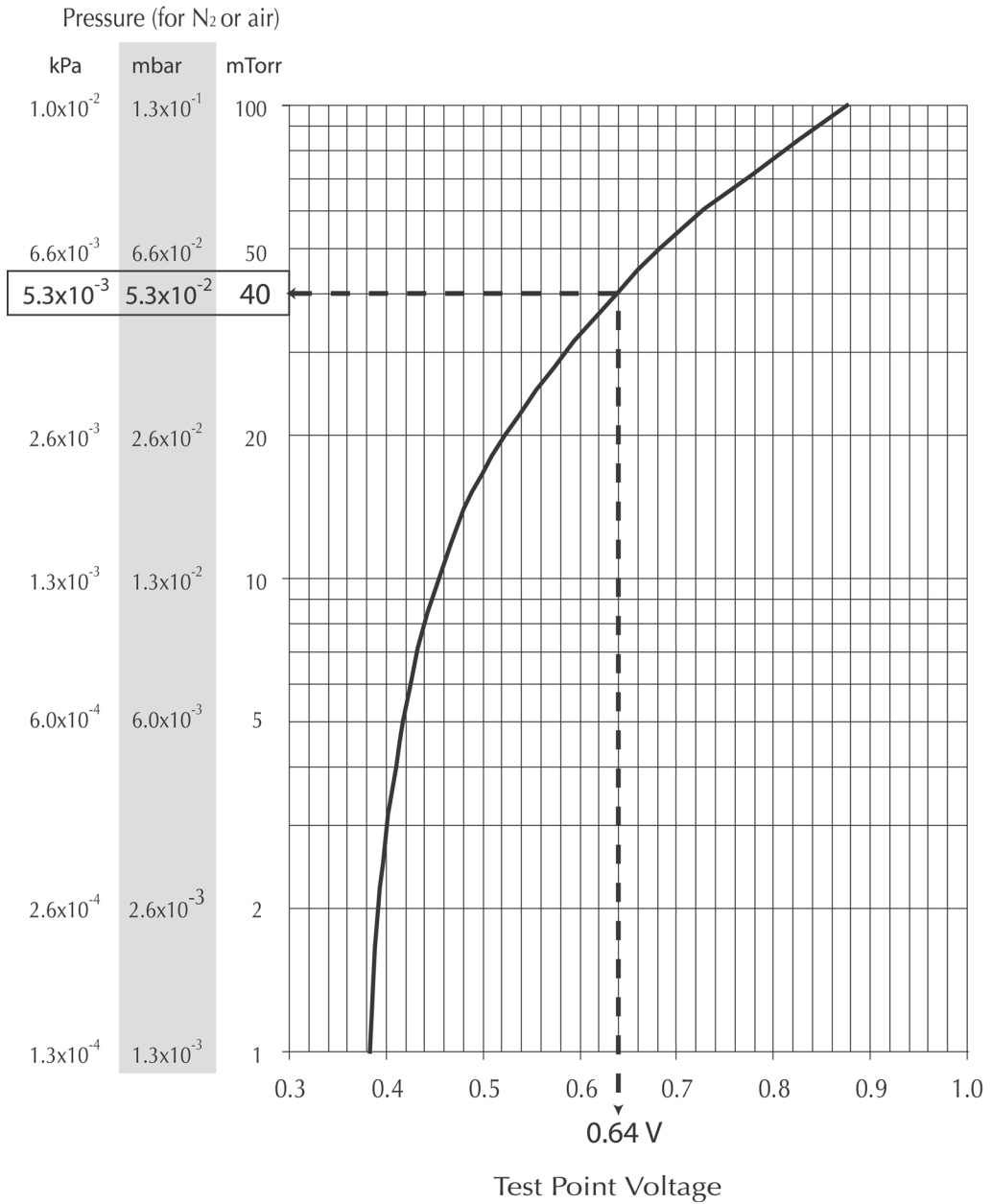

Operation

**Figure 3-11 Example Test Point Voltage: 4.8 V equals 40 Torr (5.33 kPa, 53.3 mbar) of N<sub>2</sub> or Air**

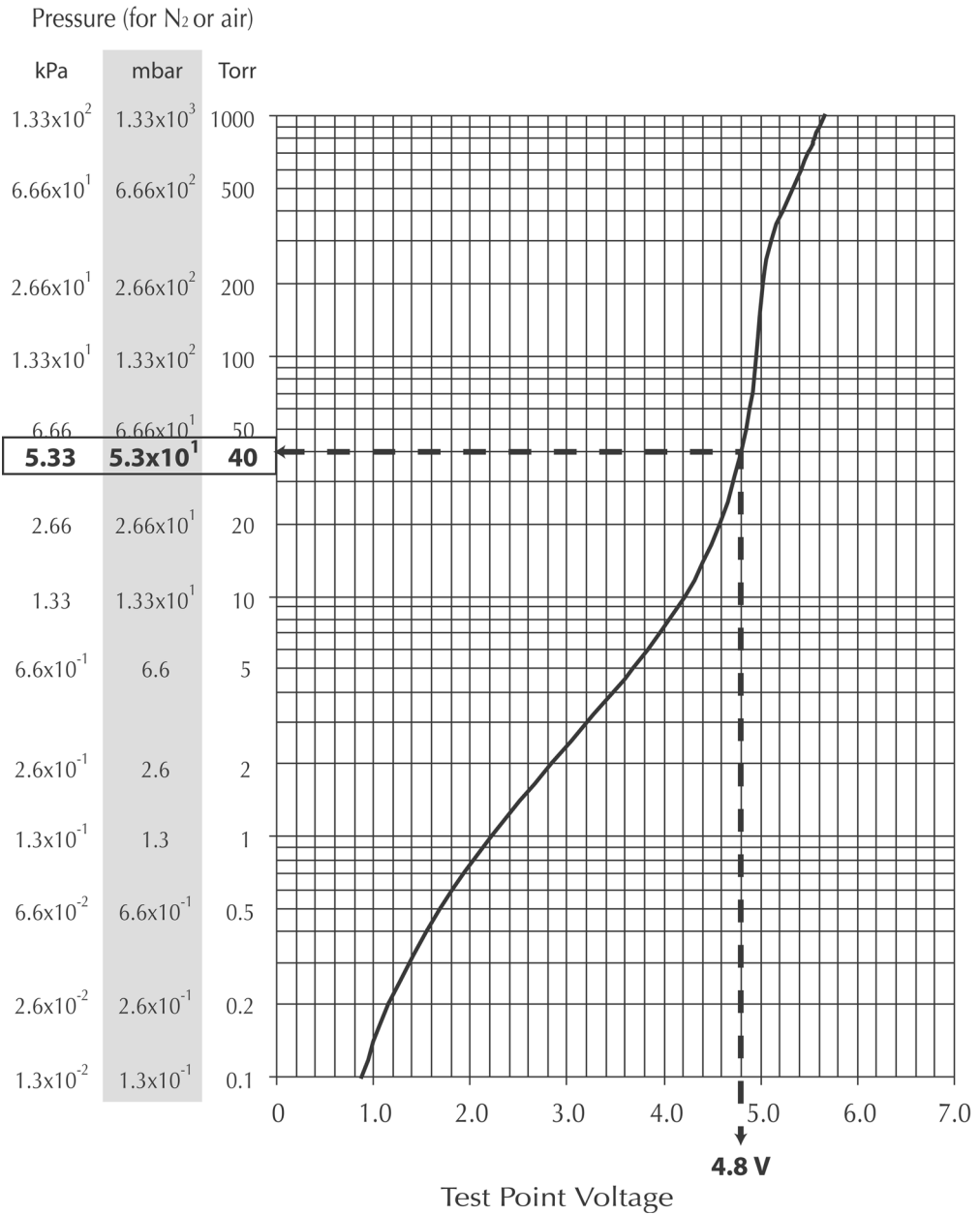

### 3.4 Reading Relay Status

If the module without a display has one setpoint relay, or if the module has the optional display, use the setpoint LEDs to read activation/deactivation status of relays.

***If the module without a display has one setpoint relay:***

The RELAY ON LED is solid green when the setpoint relay is activated.

***If the module has a digital display:***

- The RELAY ON SP1 LED is solid green when relay 1 is activated.
- The RELAY ON SP2 LED is solid green when relay 2 is activated.

You cannot read relay status if the module without a display has two setpoint relays.

### 3.5 Calibrating Convector Gauge at Atmospheric Pressure

An atmospheric pressure calibration is performed on the Convector gauge, using N<sub>2</sub>, at the factory before the module is shipped. The factory calibration sets the atmospheric calibration point for N<sub>2</sub> to 760 Torr (101 kPa, 1013 mbar) of N<sub>2</sub>.

Because performance varies depending on the process gas, you may wish to reset the atmospheric calibration point if a gas other than N<sub>2</sub> or air is being used. Periodic resets of the atmospheric calibration point also improve the accuracy and repeatability of the Convector gauge near atmospheric pressure, even if the process gas is N<sub>2</sub> or air.

Regardless of the process gas that is being used, you should always use N<sub>2</sub> or air to calibrate the Convector gauge at atmospheric pressure.

The procedure for calibrating the Convector gauge at atmospheric pressure depends on whether or not the module has the optional display.

***If the module does not have a digital display:***

1. Shut off the pump and, using N<sub>2</sub> or air, allow the vacuum chamber pressure to increase to the value at which the atmospheric pressure point will be set.
2. Use a high-precision, high-input impedance DVM to measure the voltage across the MONITOR ANALOG and MONITOR COMMON test points on the module front panel.
3. Use a flat-head instrument screwdriver to adjust the ADJUST ATMOSPHERE potentiometer to a voltage that corresponds to the atmospheric pressure at your location. Table 3-8 on page 40 lists typical atmospheric pressure at altitude/Torr/voltage relationships.

***If the module has a digital display:***

1. Shut off the pump and, using N<sub>2</sub> or air, allow the vacuum chamber pressure to increase to the value at which the atmospheric pressure point will be set.
2. When the display indicates that pressure has achieved the atmospheric pressure point, use a flat-head instrument screwdriver to adjust the ADJUST ATM potentiometer to a voltage that corresponds to the displayed pressure. Table 3-8 lists typical atmospheric pressure at altitude/pressure/voltage relationships.

**Table 3-8 Typical Atmospheric Pressures at Altitude/Pressure/Voltage Relationships**

Altitude Above Sea Level		Pressure of N <sub>2</sub> or Air			Analog Output Voltage (Vdc)
Feet	Meters	Torr	kPa	mbar	
0	0	760	101	1013	5.534
1000	305	733	97	977	5.513
2000	610	707	94	942	5.493
3000	914	681	90	908	5.473
4000	1219	656	87	874	5.454
5000	1524	632	84	842	5.435
6000	1829	609	81	812	5.417
7000	2134	586	78	781	5.399
8000	2438	564	75	752	5.382
9000	2743	543	72	724	5.366
10,000	3048	523	69	697	5.350



### 3.6 Calibrating Convectron Gauge at Vacuum Chamber Pressure

Periodic resets of the vacuum chamber calibration point improve the accuracy and repeatability of the Convectron gauge.

Regardless of the process gas that is being used, you should always use N<sub>2</sub> or air to calibrate the Convectron gauge at vacuum chamber pressure.

The procedure for calibrating the Convectron gauge at atmospheric pressure depends on whether or not the module has the optional display.

#### ***If the module does not have a digital display:***

1. Turn on the pump and, using N<sub>2</sub> or air, allow vacuum chamber pressure to descend to a pressure that is lower than 10<sup>-4</sup> Torr (1.3 × 10<sup>-5</sup> kPa, 1.3 × 10<sup>-4</sup> mbar).
2. Use a high-precision, high-input impedance ( $Z_{in} > 1\text{ M}\Omega$ ) DVM to measure the voltage across the MONITOR ANALOG and MONITOR COMMON test points on the module front panel.
3. Use a flat-head instrument screwdriver to adjust the ADJUST VACUUM potentiometer to a reading of 0.375 Vdc.

#### ***If the module has a digital display:***

1. Turn on the pump and, using N<sub>2</sub> or air, allow vacuum chamber pressure to descend to a pressure that is lower than 10<sup>-4</sup> Torr (1.3 × 10<sup>-5</sup> kPa, 1.3 × 10<sup>-4</sup> mbar).
2. When the display indicates pressure is 0.00 mTorr, use a flat-head instrument screwdriver to adjust the ADJUST VAC potentiometer to a reading of 0.375 Vdc.

### 3.7 Modules Operating at Low Pressure

During a fast pumpdown from atmospheric pressure, thermal effects temporarily prevent the module from measuring pressure accurately below 1 × 10<sup>-3</sup> Torr (1.3 × 10<sup>-4</sup> kPa, 1.3 × 10<sup>-3</sup> mbar). After approximately 15 minutes, pressure indications the 1 × 10<sup>-4</sup> Torr (1.3 × 10<sup>-5</sup> kPa, 1.3 × 10<sup>-4</sup> mbar) range will be accurate.

When pressure indication in the 1 × 10<sup>-4</sup> Torr (1.3 × 10<sup>-5</sup> kPa, 1.3 × 10<sup>-4</sup> mbar) range has stabilized, a Convectron gauge calibration at vacuum chamber pressure may be performed.

The calibration may be performed at a higher pressure if readings in the 1 × 10<sup>-4</sup> Torr (1.3 × 10<sup>-5</sup> kPa, 1.3 × 10<sup>-4</sup> mbar) range are not required. In the 1 × 10<sup>-4</sup> Torr (1.3 × 10<sup>-5</sup> kPa, 1.3 × 10<sup>-4</sup> mbar) range, resolution is ±0.1 millitorr, if the Convectron gauge has been properly calibrated at vacuum chamber pressure. If the module frequently operates in the 1 × 10<sup>-4</sup> Torr (1.3 × 10<sup>-5</sup> kPa, 1.3 × 10<sup>-4</sup> mbar) range, Convectron gauge calibration at vacuum chamber pressure should be performed frequently.

**3.8 Factory Settings** Table 3-9 lists factory relay setpoint values.

**Table 3-9 Factory Settings for Relays**

<b>Parameter</b>	<b>Factory Setting</b>
Setpoint	Below 0.0 vacuum chamber pressure
State	Deactivated
Returning pressure hysteresis	<ul style="list-style-type: none"><li>• 2% of reading for module without display</li><li>• 10% of reading + 1 significant digit for module with optional display</li></ul>
Activation direction	Activates below vacuum chamber pressure setpoint, not programmable

### 4.1 Customer Service

For customer service:

- Phone **1-303-652-4400** or **1-800-776-6543** within the USA.
- Phone **1-800-367-4887** 24 hours per day, 7 days per week within the USA
- Email *co-csr@brooks.com*
- For Global Customer Support, go to [www.brooks.com](http://www.brooks.com), click on Contact Us, then click on Global Offices to locate the Brooks Automation office nearest you.

### Damage Requiring Service

*Shut off power to the module* and refer servicing to qualified service personnel under the following conditions:

- a. If any liquid has been spilled onto, or objects have fallen into, the module.
- b. If a circuit board is faulty.
- c. If the Convectron gauge sensing wire is open or the gauge is contaminated.
- d. If the module has been exposed to moisture.
- e. If the module does not operate normally even if you follow the operating instructions. Adjust only those controls that are explained in this instruction manual. Improper adjustment of other controls may result in damage and will often require extensive work by a qualified technician to restore the module to its normal operation.
- f. If the module has been dropped or the enclosure has been damaged.
- g. If the module exhibits a distinct change in performance.

If the module requires repair:

- See *Returning a Product for Repair* on page 48.

**4.2 Troubleshooting**

If any of the conditions described on page 43 have occurred, troubleshooting is required to determine the repairs that are necessary.

**Precautions**

Because the Convector gauge contains static-sensitive electronic parts, follow these precautions while troubleshooting:

- Use a grounded, conductive work surface. Wear a high impedance ground strap for personal protection.
- Do not operate the module with static sensitive devices or other components removed from the product.
- Do not handle static sensitive devices more than absolutely necessary, and only when wearing a ground strap.
- Rely on voltage measurements for troubleshooting module circuitry. Do not use an ohmmeter.
- Use a grounded, electrostatic discharge safe soldering iron.

 **WARNING**

**Substitution or modifying parts can result in serious product damage or personal injury due to electrical shock or fire.**

- Install only those replacement parts that are specified by Helix Technology.
- Do not install substitute parts or perform any unauthorized modification to the module.
- Do not use the module if unauthorized modifications have been made.

 **WARNING**

**Failure to perform a safety check after the module has been repaired can result in serious property damage or personal injury due to electrical shock or fire.**

If the module has been repaired, before putting it back into operation, make sure qualified service personnel perform a safety check.

**Symptoms, Causes, and Solutions**

Table 4-1 lists failure symptoms, causes, and solutions.

**Table 4-1 Failure Symptoms, Causes, and Solutions**

Symptom	Possible Causes	Solution
Output voltage = 0 V	11.5 to 26.5 V power supply cable is improperly connected or faulty.	Repair or replace power supply cable (see page 17).
Pressure reading is too high.	<ul style="list-style-type: none"> <li>Conductance in connection to vacuum chamber is inadequate.</li> <li>Plumbing to module leaks or is contaminated.</li> <li>Chamber pressure is too high due to leak, contamination, or pump failure.</li> <li>Power supply or output cable is improperly connected or faulty.</li> </ul>	<ul style="list-style-type: none"> <li>If conductance is inadequate, reconnect Convector gauge port to vacuum chamber (see page 16).</li> <li>If plumbing leaks or is contaminated, clean, repair or replace plumbing.</li> <li>If pump failed, repair or replace it.</li> <li>If cable is improperly connected or faulty, repair or replace cable (see page 17).</li> </ul>
Pressure reading is inaccurate.	<ul style="list-style-type: none"> <li>Module is not calibrated for the process gas that is being used.</li> <li>Module is not mounted horizontally.</li> <li>Convector gauge or differential pressure sensor is damaged (for example, by reactive gas) or contaminated.</li> <li>Temperature or mechanical vibration is extreme.</li> </ul>	<ul style="list-style-type: none"> <li>If Convector gauge is out of calibration, recalibrate it (see page 39).</li> <li>If module is not mounted horizontally, re-mount it (see page 15).</li> <li>If Convector gauge is damaged, replace it (see page 47).</li> <li>If Convector gauge is contaminated, return it to factory (see pages 47 and 48).</li> <li>If temperature or vibration is extreme, relocate module or eliminate source of heat or vibration.</li> </ul>
Indicated pressure is different than pressure indications from other measurement devices.	<ul style="list-style-type: none"> <li>Process gas is not the gas that the user anticipated using in the system.</li> <li>Convector gauge is defective.</li> </ul>	<ul style="list-style-type: none"> <li>If the process gas is not what was anticipated, calibrate Convector gauge for gas that is being used (see page 39).</li> <li>If Convector gauge is defective, return it to factory (see pages 47 and 48).</li> </ul>
Relay LED indicator is ON, but relay is not functioning.	Relay contacts are defective.	Make sure relay load is within specified rating and is non-inductive (see page 50).
<ul style="list-style-type: none"> <li>Relay will not activate.</li> <li>Output voltage is &lt; 0.10 V.</li> </ul>	<ul style="list-style-type: none"> <li>A circuit board is faulty.</li> <li>Convector gauge sensing wire is open.</li> </ul>	Return module to factory (see page 48).

## 4.3 Convectron Gauge Test

**CAUTION**

**Performing a Convectron gauge test with instruments that apply more than 0.1 V with the gauge at vacuum chamber pressure can result in property damage.**

Do not perform a Convectron gauge test with an instrument that applies more than 0.1 V of electromotive force.

Even a small amount of voltage can damage the small diameter sensing wire inside the Convectron gauge.

To determine if the Convectron gauge sensing wire has been damaged, follow these instructions:

1. Remove the Convectron gauge as instructed on page 47.
2. Use a *low-voltage (maximum 0.1 V) ohmmeter* to check resistance values across the pins on the base of the gauge. Pin numbers are embossed on the base. Figure 4-1 illustrates the base of the gauge.

The resistance across the pins should be within the ranges listed in Figure 4-1. If resistance across pins 1 and 2 is not approximately 20 to 30  $\Omega$  or if other listed resistance values are greater than the listed values, the gauge is defective. Install a replacement Convectron gauge as instructed on page 47.

**Figure 4-1 Convectron Gauge Pins**

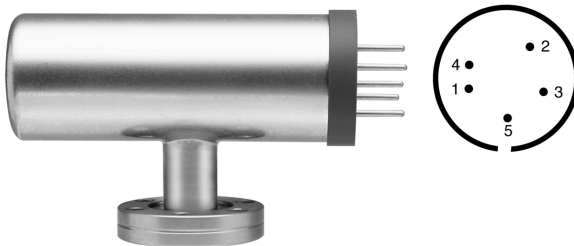

- Pins 1 to 2: 19 to 22 ohms
- Pins 2 to 3: 50 to 60 ohms
- Pins 1 to 5: 180 to 185 ohms

If the resistance from pins 1 to 2 reads about 800 ohms, the sensor wire in the gauge is broken. Replace the gauge tube.

*Note: If the resistance values shown here are correct, but you still think the gauge is not reading correctly, the gold plating on the sensor wire may be eroded and the gauge will have to be replaced.*

#### 4.4 Convectron Gauge Removal and Replacement



### WARNING

**Removing or replacing the Convectron gauge in a high-voltage environment can cause an electrical discharge through a gas or plasma, resulting in serious property damage or personal injury due to electrical shock.**

Vent the vacuum chamber to atmospheric pressure and shut off power to the module before you remove or replace the Convectron gauge.

#### Removing the Convectron Gauge

To avoid contaminating the Convectron gauge, wear sterile gloves during the removal procedure.

1. Vent the vacuum chamber to atmospheric pressure and *shut off power to the module*.
2. Use the fitting to detach the module from the vacuum chamber.
3. Remove the four Phillips-head screws from both module end plates, but do not remove the hex nuts that hold the D subminiature connector in place.
4. Remove the end plate that does *not* have a connector, then remove both sides of the blue housing.
5. *Carefully* unplug the Convectron gauge from the spring-loaded sockets in the printed circuit board.

#### Replacing the Convectron Gauge

To avoid contaminating the Convectron gauge, wear sterile gloves during the replacement procedure.

1. *Shut off power to the module*.
2. Align the gauge pins so they mate with spring-loaded sockets in the printed circuit board. *Carefully* insert the Convectron gauge pins into the sockets.
3. Position the end plates and put both blue parts of the housing into place, making sure the gauge grounding springs and cradles are in line with the gauge envelope.
4. Re-install the Phillips-head screws into the end plates.
5. Use the fitting to re-attach the module to the vacuum chamber.

**4.5 Returning a Product for Repair**

If the module must be returned for service, request a Return Authorization (RA) from Brooks Automation, Inc. / Granville-Phillips. Do not return products without first obtaining an RA. In some cases a hazardous materials document may be required. The Brooks Automation / Granville-Phillips Customer Service Representative will advise you if the hazardous materials document is required.

When returning equipment to Brooks Automation Inc. / Granville-Phillips, be sure to package the products to prevent shipping damage. Circuit boards and modules separated from the controller chassis must be handled using proper anti-static protection methods and must be packaged in anti-static packaging. Brooks Automation, Inc. / Granville-Phillips will supply return packaging materials at no charge upon request. Shipping damage on returned products as a result of inadequate packaging is the Buyer's responsibility. *Before you return the module*, obtain an RA number by contacting Granville-Phillips customer service:

- Phone **1-303-652-4400** or **1-800-776-6543** within the USA.
- Phone **1-800-367-4887** 24 hours per day, 7 days per week within the USA.
- Email *co-csr@brooks.com*

For Global Customer Support, go to [www.brooks.com](http://www.brooks.com), click on Contact Us, then click on Global Offices to locate the Brooks Automation office nearest you.



# Appendix A Specifications

## Pressure Measurement

---

<b>Measurement Range for Air or N<sub>2</sub></b>	Torr	1 x 10 <sup>-4</sup> to 1000
	mbar	1 x 10 <sup>-4</sup> to 1333
	Pascal	1 x 10 <sup>-2</sup> to 1.33 x 10 <sup>5</sup>
<b>Resolution</b>	Torr	1 x 10 <sup>-4</sup>
	mbar	1 x 10 <sup>-4</sup>
	Pascal	1 x 10 <sup>-2</sup>

Measurements will change with different gases and mixtures. Do not use the module with flammable or explosive gases. The module is factory calibrated for use on N<sub>2</sub>. It also measures the pressure of air correctly within the accuracy specification for the instrument. If the module will measure the pressure of a gas other than N<sub>2</sub> or air, you must adjust relays for the process gas.

## Temperature Limits

---

<b>Operating Temperature</b>	+0 to +40 °C (+32 to +104 °F) ambient, non-condensing
<b>Non-operating Temperature</b>	-40 to +70 °C (-40 to +158 °F)

## CE Compliance

---

<b>Declaration of Conformity</b>	To obtain a declaration of conformity, phone <b>1-303-652-4400</b> or <b>1-800-776-6543</b> within USA, or email <a href="mailto:co-csr@brooks.com">co-csr@brooks.com</a> .
----------------------------------	---

## Power Requirements and Electrical Connections

---

### Power Requirements

<i>With optional display</i>	11.5 to 26.5 Vdc, 0.15 A at 11.5 Vdc, 3.5 W maximum
<i>Without display</i>	11.5 to 26.5 Vdc, 0.1 A at 11.5 Vdc, 1.6 W maximum

### I/O connectors

<i>2 setpoint relays</i>	15-pin male, high-density subminiature D
<i>1 setpoint relay</i>	9-pin male, subminiature D

## Relays and outputs

---

### Setpoint Relays

<i>Relay type</i>	Single-pole, double-throw (SPDT), Form A
<i>Contact rating</i>	1 A at 30 Vdc resistive, 30 VAC non-inductive
<i>Range</i>	Torr $1 \times 10^{-3}$ to 1000 mbar $1 \times 10^{-3}$ to 1333 Pascal $1 \times 10^{-1}$ to $1.33 \times 10^5$
<i>Hysteresis</i>	2% of reading for module without display 10% of reading plus 1 significant digit for module with optional display
<i>Resolution</i>	Two significant digits

### Analog Output

0.375 to 5.659 Vdc for 0 to 1000 Torr of N<sub>2</sub>, non-linear  
 0 to 1333 mbar of N<sub>2</sub>, non-linear  
 0 to  $1.33 \times 10^{-1}$  kPa of N<sub>2</sub>, non-linear

## Mini-Convector Gauge

---

<b>Sensing Wire Filament</b>	Gold-plated tungsten (standard) or solid platinum (optional)
<b>Internal Volume</b>	35 cm <sup>3</sup> (2.14 in. <sup>3</sup> )
<b>Materials Exposed to Vacuum</b>	304 stainless steel, gold, borosilicate glass, kovar, alumina, NiFe alloy, polyimide
<b>Bakeout Temperature</b>	150 °C (302 °F) maximum, non-operating, with electronics removed

## Physical Characteristics

---

<b>Mounting Position</b>	Horizontal axis (see page 15)
<b>Case Material</b>	Powder-coated extruded aluminum
<b>Weight</b>	340 g (12 oz.) with 1/8 NPT fitting

*Dimensions*

Dimensions are in cm (in.)

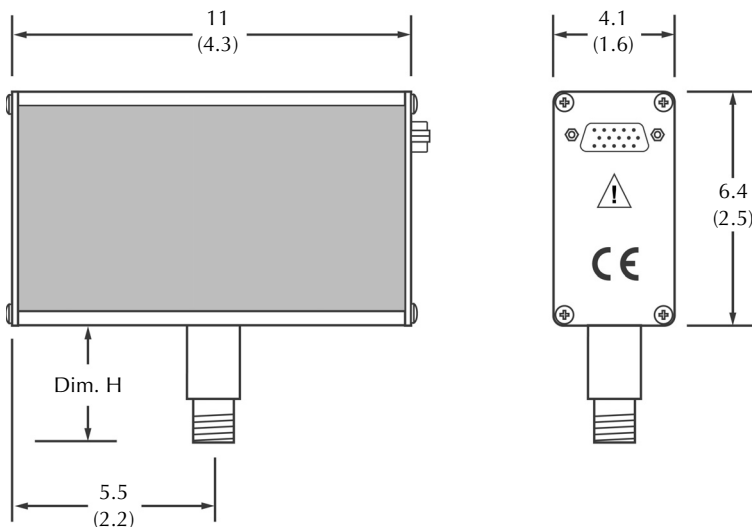

Vacuum Connections	Dim. H	
	cm	in.
1/8 NPT pipe thread, 1/2-inch inside diameter	2.2	0.9
1/2-inch 4 VCR® type fitting, female	3.0	1.2
1/2-inch 8 VCR type fitting, female	3.9	1.5
NW16KF flange	3.1	1.2
NW25KF flange	3.1	1.2
NW40KF flange	3.7	1.5
1.33-inch (NW16CF) ConFlat® flange	3.8	1.5
2.75-inch (NW35CF) ConFlat flange	3.8	1.5

**Optional Display**

**Pressure Units**

Torr or mTorr

**Pressure Value**

Green 3-digit LED, automatic ranging from Torr to mTorr



## Appendix B Theory of Operation

The module measures gas pressures from  $1 \times 10^{-4}$  Torr to 1000 Torr. Vacuum chamber pressure is measured by a Convectron convection-enhanced Pirani heat-loss gauge.

The Convectron gauge operates like a standard Pirani gauge, which employs the principle of a Wheatstone bridge to convert pressure to voltage, but uses convection cooling to enable accurate pressure measurement, when properly calibrated, from  $10^{-4}$  to 1000 Torr.

The sensing wire is an ultra-fine strand of gold-plated tungsten or solid platinum. The heated sensing wire loses more heat as the ambient gas pressure increases. The more molecules contact the sensing wire, the more power is required to keep the sensing wire at a constant temperature. So, as pressure increases, the voltage across the Wheatstone bridge also increases.

The Convectron gauge has a temperature compensator, which causes bridge voltage to remain unaffected by changes in ambient temperature.

Figure B-1 is a diagram of the module controller. The Convectron gauge sensing wire is designated  $R_1$  in the Wheatstone bridge circuit. The temperature compensator is designated  $R_2$ . At bridge null, the following equation applies:

$$R_1 = \frac{R_2 + R_3}{R_4}$$

Bridge voltage is a non-linear function of pressure. This relationship is illustrated in Figure B-1. If the ambient temperature does not change,  $R_1$  remains constant.

**Figure B-1 Wheatstone Bridge Diagram**

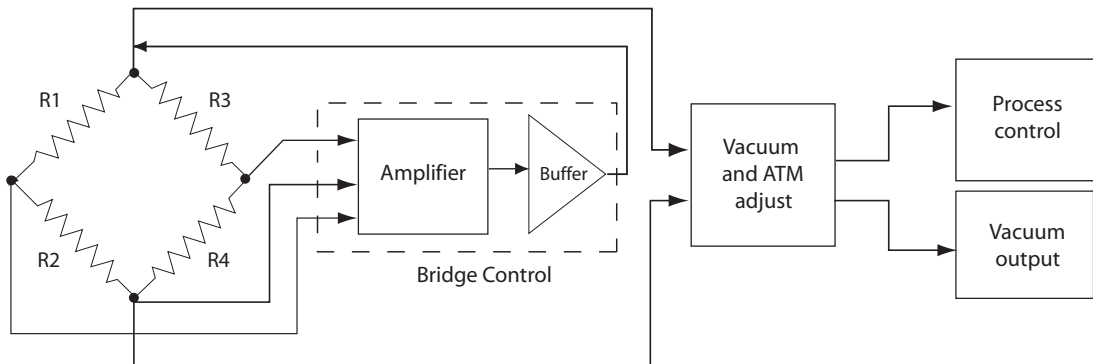

As vacuum chamber pressure decreases, the number of molecules in the vacuum chamber and the resulting heat loss from the sensing wire also decrease. Temperature and  $R_1$  resistance therefore increase.

The increased resistance through  $R_1$  causes the bridge to become unbalanced and a voltage to develop across the null terminals. The bridge controller senses the null voltage and decreases the voltage across the bridge until the null voltage again equals zero. When the bridge voltage decreases, the power dissipation in the sensing wire decreases, causing  $R_1$  resistance to decrease to its previous value.

A pressure increase causes an opposing series of occurrences, during which the bridge controller increases the bridge voltage to maintain a zero null voltage.

## A

- Analog output
  - voltage versus commonly used gas pressure **26**
  - voltage versus N<sub>2</sub> or air pressure **27–29**
  - voltage versus other gas pressure **26**
  - wiring **17**

## Appendixes

- Specifications **49**
- Theory of Operation **53**

## B

- Before you begin **7**

## C

- Calibration
  - at atmospheric pressure **39**
  - at vacuum chamber pressure **41**
  - Convectron gauge **19**
- Caution and warning statements **8**
- Chapters
  - Before you Begin **7**
  - Installation **11**
  - Maintenance **43**
  - Operation **21**
- Commonly used gases **26**
- Components of module
  - with one relay, no display **11, 23**
  - with two relays, no display **11, 24**
  - with two relays, optional display **12, 22**
- Connecting cable **17**
- Connections to vacuum chamber **14, 51**
- Convectron gauge
  - calibration at atmospheric pressure **39**
  - calibration at vacuum chamber pressure **41**
  - internal volume **50**
  - Pins **46**
  - removal **47**
  - replacement **47**
  - sensing wire filament **50**
  - setpoint relays **34–38**
  - test **46**
- Customer service **7, 43**

## D

- Damage requiring service **43**

## F

- Factory settings for module **42**

## Figures

- 15-pin connector, module with two relays **17**
- 9-pin connector, module with one relay **17**
- Convectron gauge base **46**
- example test point voltage **37–38**
- ground connection to vacuum chamber **18**
- module dimensions **14**
- module orientation **15**
- module with one relay, no display **23**
- module with optional display **12**
- module with two relays, no display **22, 24**
- module without display **11**
- output voltage versus N<sub>2</sub> or air pressure
  - 0.1 Torr to 1000 Torr **29**
  - 1 mTorr to 100 mTorr **28**
- setpoint relay behavior **34**
- true pressure versus indicated pressure
  - 10<sup>-1</sup> to 1000 Torr **32–33**
  - 10<sup>-4</sup> to 10<sup>-1</sup> Torr **31**
- Wheatstone bridge diagram **53**

## Fittings

- 1/8 NPT pipe thread **16**
- ConFlat flange fitting **16**
- KF flange **16**
- VCR type **16**

## Front panel features

- with one relay, no display **23**
- with one relay, optional display **22**
- with two relays, no display **24**

## G

### Ground

- connection to vacuum chamber **18**
- wiring **18**

## I

### I/O connector

- 15-pin for module with two relays **17**
- 9-pin for module with one relay **17**

Implosion / Explosion **9**

Indicators

analog setpoints **22, 23, 24**

Installation **11**

attaching module to vacuum chamber **16**

calibrating Convectron gauge **19**

configuring relays for application **19**

locating and orienting module **13**

module components **11**

mounting position **50**

pressure relief devices **12**

wiring **17**

Instructions

about **7**

installation **11**

maintenance **43**

module operation **21**

## L

LETHAL VOLTAGES **8**

## M

Maintenance **43**

Convectron Gauge Pins **46**

Convectron gauge removal **47**

Convectron gauge replacement **47**

Convectron gauge test **46**

customer service **43**

damage requiring service **43**

failure symptoms, causes, and solutions **45**

returning a damaged module **48**

troubleshooting **44**

troubleshooting precautions **44**

Module

analog output **26**

analog output from **26**

analog output specifications **50**

attaching to vacuum chamber **16**

components

with one relay, no display **11, 23**

with two relays, no display **11, 24**

with two relays, optional display **12, 22**

dimensions **51**

front panel features

with one relay, no display **23**

with two relays, no display **24**

with two relays, optional display **22**

location **13**

operation **21**

operation at low pressure **41**

orientation **15**

other gases **26**

physical characteristics **50**

power supply **49**

preparing to operate **21**

returning if damaged **48**

setpoint relays **34–38**

temperature **49**

## O

Operation

analog output **26**

at low pressure **41**

preparing module **21**

setpoint relay behavior **34**

setpoint relays **34–38**

tasks and page references for **25**

Optional display

power supply voltage for **49**

specifications **51**

## P

Potentiometers

Convectron ATM adjust **22, 23, 24**

Convectron VAC adjust **22, 23, 24**

Diaphragm ATM zero adjust **22, 23, 24**

setpoint 1 adjust **22, 23, 24**

setpoint 2 adjust **22, 23, 24**

Power supply

voltage with optional display **29, 49**

voltage without optional display **49**

wiring **17**

Precautions for troubleshooting **44**

Pressure

atmospheric at altitude/pressure/voltage relationships **40**

relief devices **12**

true versus indicated **31–33**

versus analog output voltage **27–30**



- 
- ## **R**
- Reading and following instructions **10**
  - Reading setpoints **39**
  - Relief devices **12**
  - Returning a damaged module **48**
- ## **S**
- Setpoint relays
    - behavior **34**
    - configuring for application **19**
    - contact rating **50**
    - reading **39**
    - test point voltage versus pressure **37–38**
    - type **50**
    - wiring **17**
  - Specifications **49**
    - analog output **50**
    - Convectron gauge internal volume **50**
    - Convectron gauge sensing wire **50**
    - I/O connector **49**
    - module dimensions **51**
    - mounting position **50**
    - optional display **51**
    - physical characteristics **50**
    - power supply **49**
    - setpoint relays **50**
    - temperature **49**
    - vacuum connections **14, 51**
  - System Grounding **8**
- ## **T**
- Temperature
    - non-operating **49**
    - operating **49**
  - Testing Convectron gauge **46**
  - Theory of operation **53**
  - Troubleshooting **44**
    - failure symptoms, causes, and solutions **45**
    - precautions **44**
- ## **V**
- Vacuum chamber
    - 1/8 NPT pipe thread fitting **16**
    - attaching module to **16**
    - ConFlat flange **16**
    - connections **14, 51**
    - ground connection to **18**
    - KF flange fitting **16**
    - VCR type fitting **16**
  - Voltage
    - analog output versus pressure **27–30**
    - example test point **37–38**
    - power supply with optional display **29, 49**
    - power supply without optional display **49**
- ## **W**
- Wiring
    - analog output **17**
    - connecting cable **17**
    - ground connection to vacuum chamber **18**
    - grounding **18**
    - I/O connector
      - module with one relay **17**
      - module with two relays **17**
      - specifications **49**
    - installation **17**
    - power supply **17**
    - terminals **17**





## Series 275

# Granville-Phillips® Series 275 Mini-Convectron® Vacuum Gauge Module with Nonlinear Analog Outputs and Process Control Relays



**6450 Dry Creek Parkway**

Longmont, CO 80503 USA

Phone: 1-303-652-4400

**15 Elizabeth Drive**

Chelmsford, MA 01824 USA

Phone: 1-978-262-2400

Worldwide Customer Service/Support - 24/7

Phone: 1-800-367-4887

To obtain a copy of this instruction manual online,  
visit our website at [www.brooks.com](http://www.brooks.com)

(Adobe® Reader® version 5.0 or higher required)

© 2004-2008 Brooks Automation, Inc.

## Instruction Manual

*Instruction manual part number 275512*

*Revision 03 - June 2008*