

Understanding Amptek's Silicon Drift Detectors

Amptek, Inc. provides silicon drift detectors (SDDs) and a faster configuration, the FastSDD, along with SiPIN and CdTe X-ray detectors. SDDs are a mature X-ray detector technology offering higher performance than conventional planar detectors. An SDD has less electronic noise than a comparable planar detector, at short peaking times. The FastSDD has even lower electronic noise at short peaking times. This gives the SDD better energy resolution than an SiPIN at moderate count rates and much better energy resolution at high count rates. The difference is most significant at low energies (where Fano broadening is least.) This application note will provide some background information on SDDs, on how they compare to planar detectors, and when they are recommended.

Introduction

Figure 1 shows spectra taken with a 25 mm² SDD and a 25mm² planar detector. The spectra on the left were taken at a long peaking time (25.6 μ s) and 5 kcps count rate. The SDD (filled gray) has better resolution but the difference is small and the peaks are well resolved for both detectors. The spectra on the right were taken at a short peaking time (2.4 μ s) and 25 kcps count rate. The SDD resolution is much better than that of the planar detector. In fact, the SDD resolution is nearly the same in the two plots: the Pb L _{α} line (10.55 keV) is 185 (190) eV FWHM at 25.6 (2.4) μ s. With an SDD, low energy peaks can be measured at a high count rate with little loss of resolution. This is its key advantage.

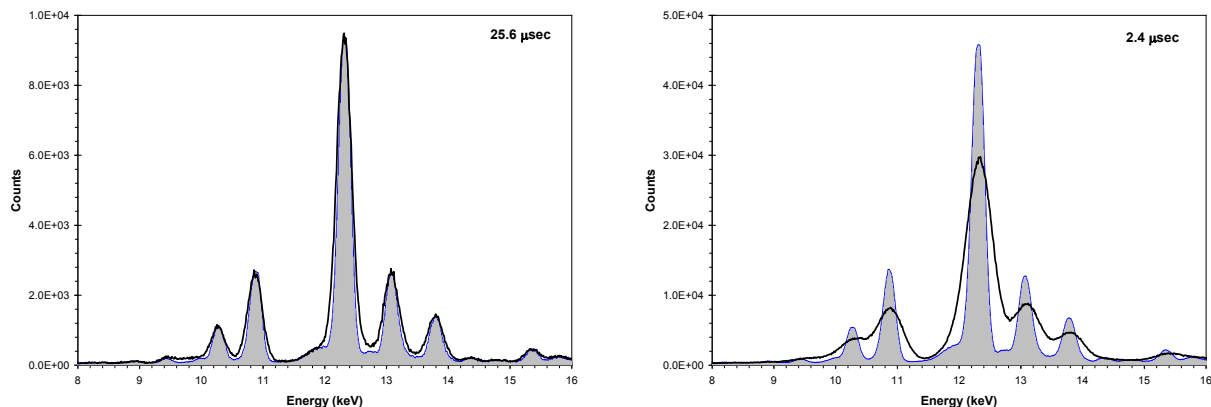
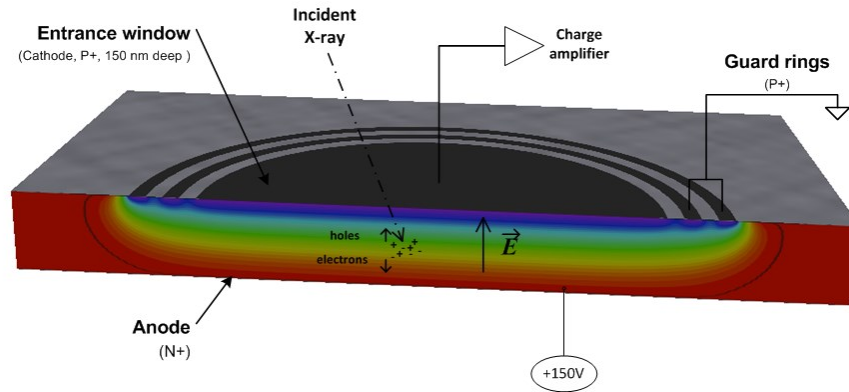

Figure 1. Spectra taken by a 25 mm² SDD (filled) and a 25 mm² planar diode (black) of a RoHS/WEEE reference material, containing about 1000 ppm each of Cr, Br, Hg, and Pb in a polyethylene matrix. The spectra on the left were taken using a 25.6 μ s peaking time, at 5 kcps, while those on the right were taken at a 2.4 μ s peaking time at 25 kcps.

An SDD is a special type of photodiode, functionally similar to a planar photodiode but with a unique electrode structure. It has much lower capacitance than a planar diode of the same area, and since electronic noise at short shaping times is proportional to capacitance, the SDD yields much lower noise at short shaping times. This gives better energy resolution and high count rates.

Figure 2 is a sketch of a planar detector, often called a SiPIN. Fabricated out of low resistivity n-type silicon, it has a large planar contact on both the front and back sides (N⁺ on the back, P⁺ on the front, forming the junction). A bias across the detector forms an electric field. When an X-ray interacts, producing a pulse of charge, the field sweeps the carriers across to the contacts; this transient current pulse is the signal, integrated by a charge amplifier. The detector's resolution is limited by electronic noise, which arises from two main terms (see Amptek's note on "Understanding Energy Resolution). Dark current through the detector leads to shot noise, dominant at long peaking times, while thermal noise in the FET produces noise proportional to the detector's capacitance; this is dominant at short peaking times.



Sketch illustrating the design and operation of a planar SiPIN detector.

The SDD looks similar but the backside has a special electrode structure: a series of drift rings which produce a radial field, guiding the electrons to a very small, low capacitance anode (0.035 pF in Amptek's 25 mm² SDD). Electrons produced throughout the active volume drift to the signal anode, which is connected to a discrete JFET where the signal current is collected. The much lower capacitance leads to much less high frequency noise, thus reducing the noise at short peaking times and allowing operation at higher count rates.

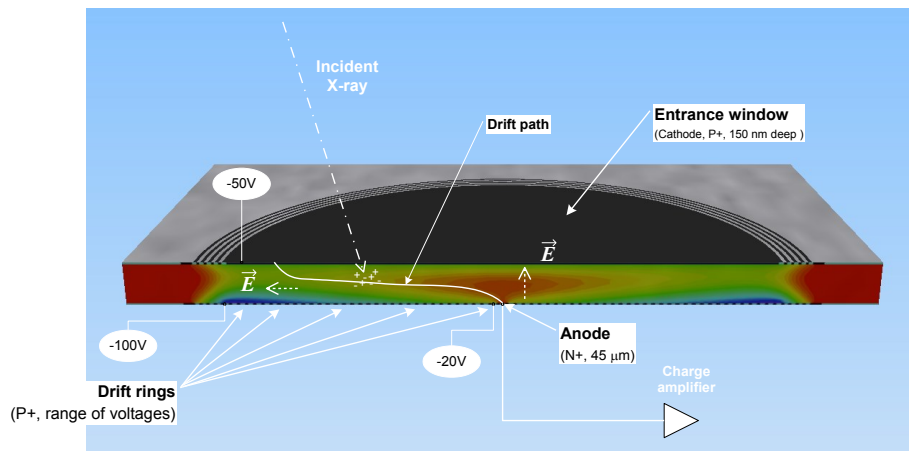

Sketch illustrating the design and operation of a silicon drift detector (SDD).

The SDD is a very mature technology, benefiting from much research over many years. The concept of the SDD was introduced in 1984 by Gatti and Rehak [1]. The first SDDs were optimized for position sensing. In 1985, Rehak et. al. proposed optimizing SDDs for X-ray spectroscopy [2]. The early SDDs required drift rings on both sides, but in 1987, Kemmer et. al. introduced a structure requiring drift electrodes on only one side and other significant improvements in the design [3]. Since then, many papers have been written describing the design and fabrication of SDDs. Several national laboratories and companies have design, built, and used SDDs. Amptek's SDDs build on a very mature technological basis. Amptek, Inc. developed its custom SDDs to meet the unique requirements of OEM manufacturers of EDXRF instruments.

Amptek's 25 mm² SDD is an outstanding detector for energy dispersive X-ray spectroscopy, with an energy resolution of 12 eV FWHM at the 5.9 keV Mn K_α line [4] at 9.6 μs T_{peak}, corresponding to an electronic noise of only 45 eV FWHM (5.3 e- rms), without cryogenic cooling.

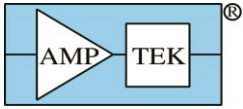

What are the advantages of an SDD?

The main advantage of the SDD is that it has much lower electronic noise than a planar device at short shaping times, i.e. at high count rates. Lower noise implies better resolution, particularly at low energies. With an SDD, the resolution is good even for large areas. Overall, the resolution of the SDD is better than that of the planar detector, but the advantages are particularly important at low energies, high count rates, and for larger areas.

As shown below, the SDD (25 mm²) has a resolution of 150 eV FWHM at T_{peak}=1.6 μs, supporting an input count rate (ICR) of 300 kcps. The 6 mm² planar detector has a resolution of 150 eV FWHM, but only at T_{peak}=25.6 μs, for count rates of 20 kcps. The SDD can maintain good resolution at 15x the count rate of the planar detector.

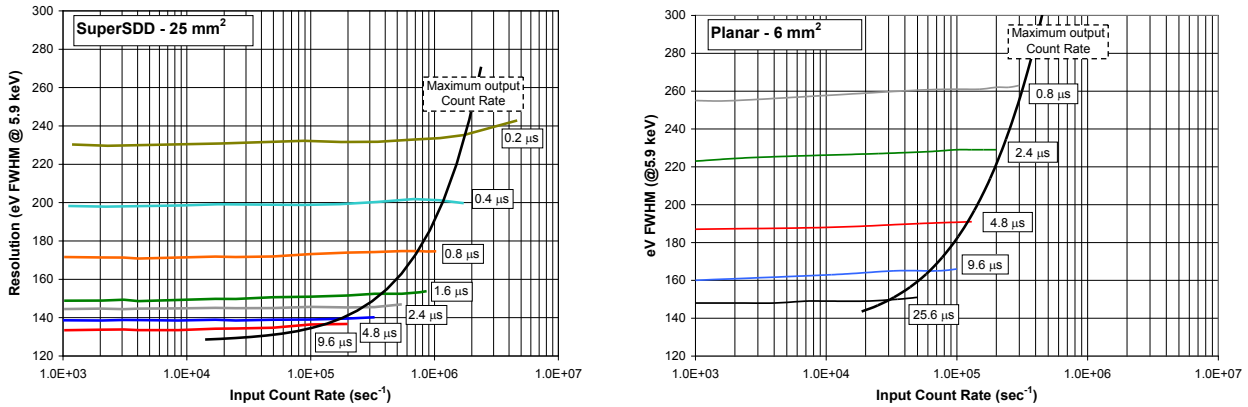

Plots showing resolution vs input count rate for a 25 mm² SDD (left) and a 6 mm² SiPIN (right).

The plot below shows how much better the SDD is at short peaking times (high count rates). It also shows that, for a planar detector, the resolution degrades significantly worse as the area increases. The resolution of an SDD is much less dependent on area: a 25 mm² SDD has somewhat better resolution than 6 mm² SiPIN and much better than the 25 mm² SiPIN. The SDD can maintain good resolution over large areas.

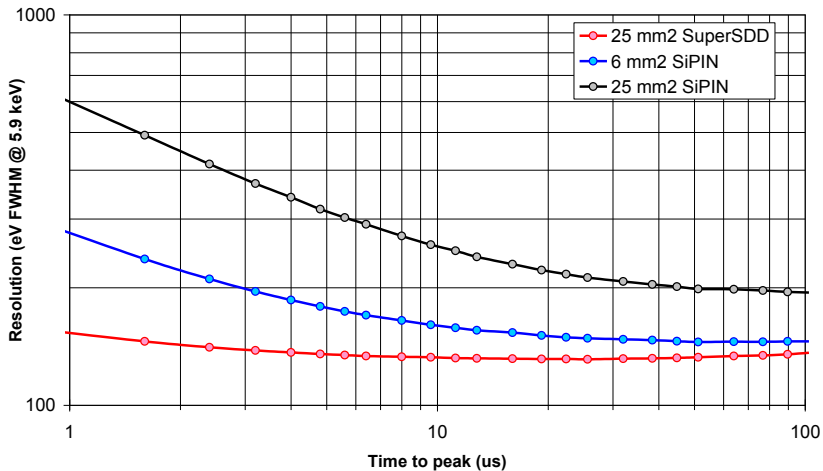

Plot showing energy resolution vs peaking time for the 25 mm² SDD, the 6 mm² SiPIN, and the 25 mm² SiPIN. This is the resolution at the 5.9 keV Mn Kα peak, at full cooling.

When comparing all detectors at their optimum, the resolution of the SDD is best: 126 eV FWHM versus a 6 mm² SiPIN which yields 145 eV FWHM. There are applications where this difference is

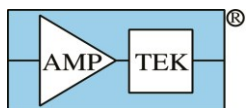

important, where the detectors are operated at this optimum. In most practical applications of XRF, however, it is the combination of resolution and count rate which is most important.

What are the disadvantages of an SDD?

The primary disadvantage of SDDs is that they are more complex devices to fabricate and operate. The fabrication of the diode chip itself, its packaging in the detector hybrid, and its handling during manufacturing are all more challenging than with a Si-PIN. This has historically resulted in lower yields and higher costs. Amptek's SDD is much less expensive than other SDDs but still more expensive than Amptek's planar detectors.

Is the SDD the best detector?

It might seem that the SDD is always the best detector. Its advantages are clear: excellent energy resolution and high count rates. The disadvantage is that it is more difficult to fabricate and thus more expensive. Better energy resolution is always good (everything else being equal), so detector manufacturers usually stress energy resolution to differentiate their products. Handling higher count rates is also good, everything else being equal. But other things are not equal (the SDD is more expensive). There are quite a few applications in which the lower noise and improved resolution are not important, many applications where the higher count rates are not important, and for these applications the lower cost planar device can be superior.

The SDD can handle higher count rates, but the detector is not always what limits count rates. In many cases, the flux from the excitation source (the X-ray tube) may only give a few thousand counts per second in the detector. The SDD's main advantage is at short shaping times, to permit high count rates. If the rate is low enough, then the longer peaking time is fine, and the SDD's resolution is only a bit better than that of the planar detectors.

Depending on the energy of the X-ray, the SDD's lower noise may not be significant. The total resolution results from both electronic noise and statistical fluctuations in the charge produced by the X-ray interaction, with the terms adding in quadrature. The statistical fluctuations increase with energy and are often much larger than the noise. At the 5.9 keV Mn K_{α} line, the statistical fluctuations contribute 118 eV, while for the SDD the noise contributes 43 eV for a total of 126 eV FWHM.

Figure 2 and Figure 3 illustrate this in actual spectra. These figures show spectra taken from a Pb-Sn solder sample using a 25 mm² SDD and a 25 mm² planar detector. The SDD had shorter peaking time and 3x the count rate. At the highest energies, the Sn K_{α} and K_{β} lines are indistinguishable. Statistical broadening is so dominant that the lower noise of the SDD is not important here. At the moderate energies, 10 to 15 keV, the SDD clearly has better resolution: the peak widths are a bit less and the peak heights slightly greater. But all of the peaks can be resolved from each other and the background equally well. The SDD has better resolution but it is unlikely to affect the analysis very much. At the lowest energies, below 5 keV, the difference is quite significant. Peaks are resolved with the SDD which overlap with the SiPIN and the peak to background ratio is much better.

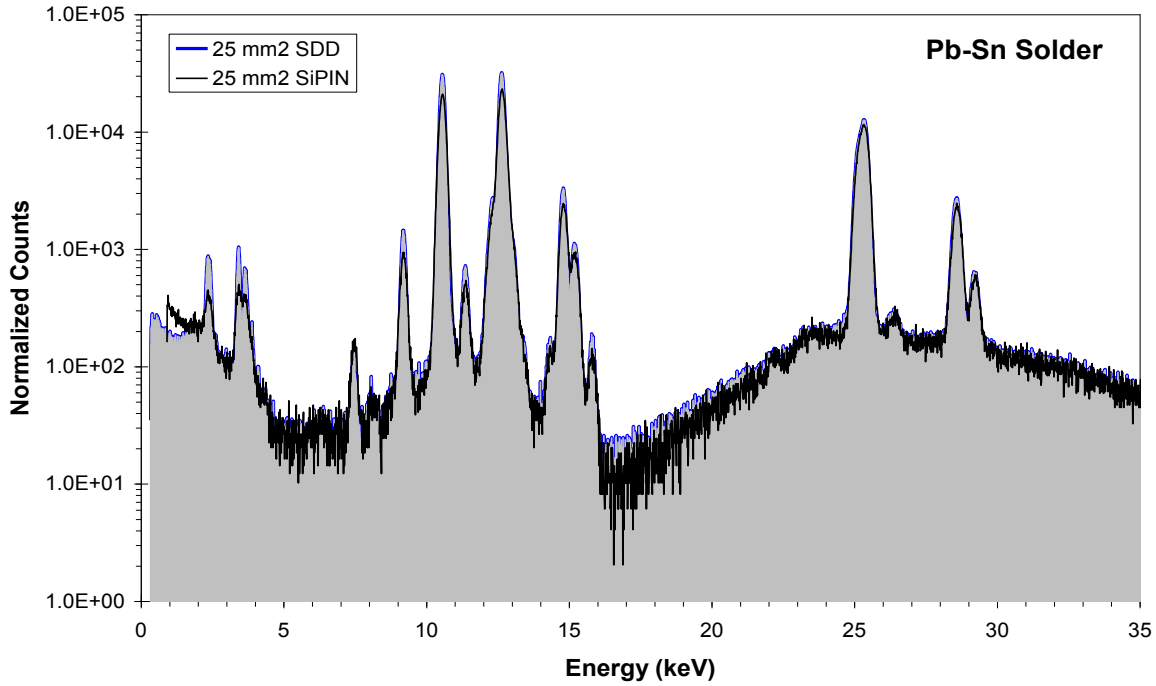

Figure 2. Spectra taken from a Pb-Sn solder using a 25mm² SDD (filled gray) and a 25 mm² planar detector (black trace). The SDD spectrum was taken at a shorter peaking time, with 3x higher count rate.

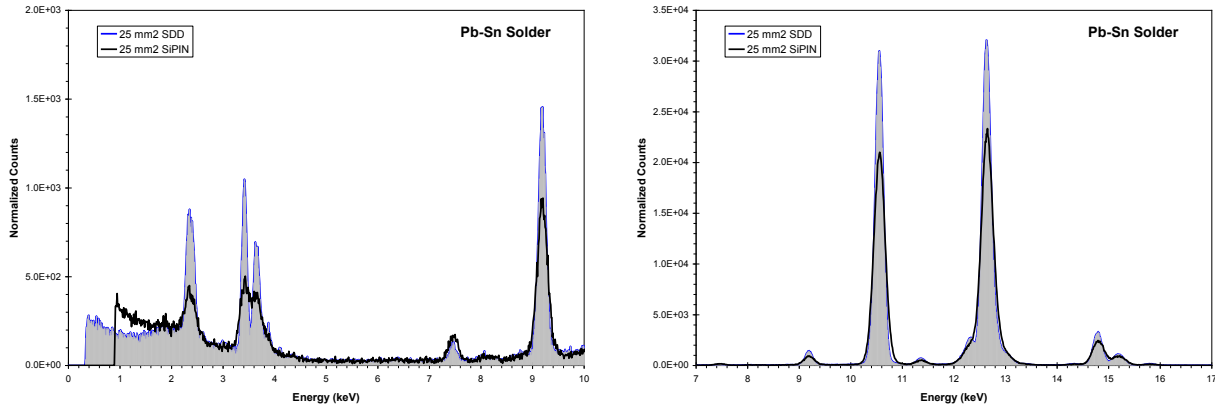

Figure 3. Same data as shown in Figure 2 but on a linear scale, concentrating on the low and medium energy portion.

Figure 4 shows the energy resolution versus X-ray energy, where each curve corresponds to the resolution measured at the Mn K_α line. At low energy, the SDD has much better resolution than the others at low energy, but up around 30 keV the difference is small. This plot also shows the count rate effect: a 25 mm² SDD at 70 kcps has a resolution comparable to a 6 mm² planar detector

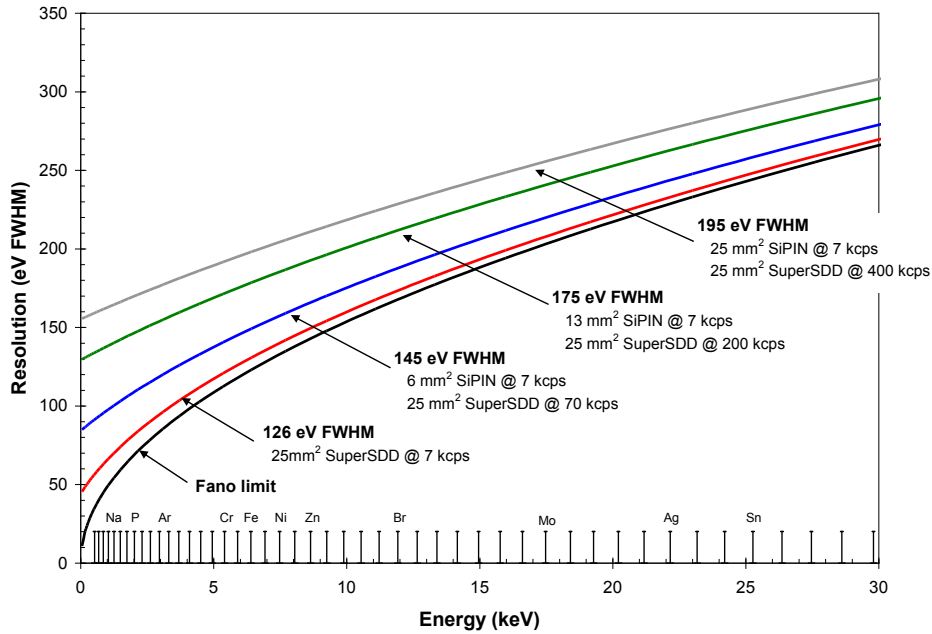

Figure 4. Plot showing energy resolution versus X-ray energy for several detector configurations. Each curve represents what is seen with resolution measured at 5.9 keV. The “126 eV” detector yields 126 eV FWHM with the Mn K_{α} line but <50 eV FWHM at low energy.

The important of energy resolution also depends on the spectrum to be measured. Energy resolution helps one to separate closely spaced peaks and to separate the peak from the background. If a spectrum only has a few peaks, widely spaced and well above background, high resolution is not important. In the Sn-Pb solder of Figure 2, the Sn K_{α} and K_{β} peaks do not overlap with other peaks and are well separated from background even with moderate resolution. One does not need high resolution. All of the peaks between 10 and 15 keV are Pb L lines. There is no great need to separate them. On the other hand, in the spectra of Figure 1, the Br K_{α} line (11.92 keV) and the Hg L_{β} line (11.82 keV) overlap considerably. Good energy resolution is quite important for this case.

How does a drift diode work?

A conventional Si-PIN photodiode is sketched in Figure 5. There are two planar contacts, the anode and the cathode, with a uniform electric field between them. An X-ray interacts at some location, ionizing the Si atoms and producing electron-hole pairs. The electric field sweeps the carriers to their respective contacts, causing a transient current pulse $I(t)$ to flow through the diode. The cathode is connected to a charge sensitive preamplifier and to pulse processing electronics, which detect the pulse and measure its amplitude. The traces at the bottom illustrate the pulse shapes at the various signal processing stages.

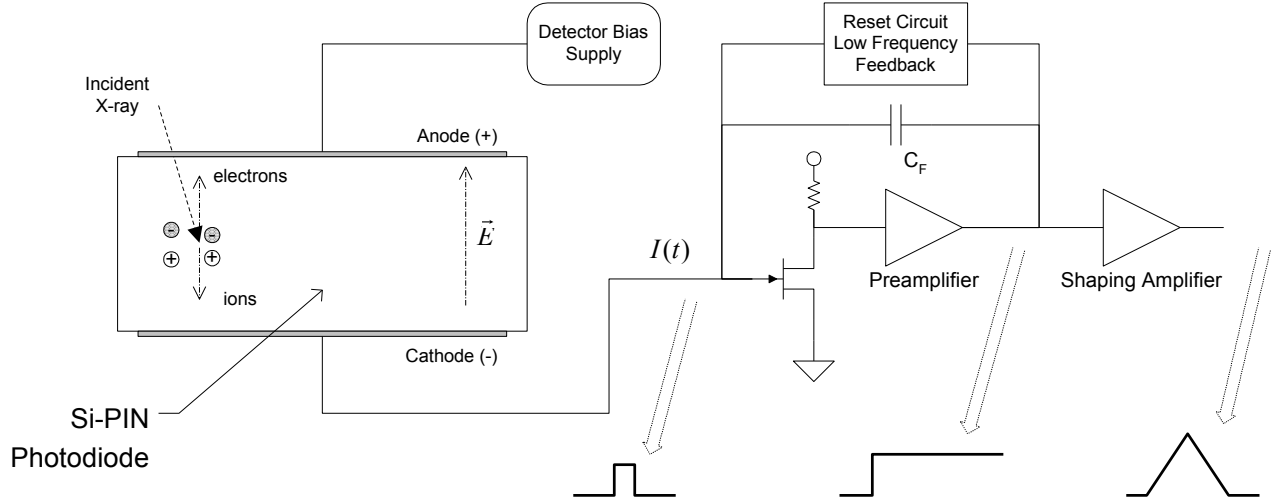

Figure 5. Sketch illustrating the operation of a conventional photodiode.

The drift diode, sketched in Figure 6, uses a planar cathode but the anode is very small and surrounded by a series of electrodes. The SDD is cylindrically symmetric, so the anode is a small circle and the drift electrodes are annular. These electrodes are biased so as to create an electric field which guides the electrons through the detector, where they are collected at the anode. The rest of the signal processing electronics is nearly identical to that used with the Si-PIN diode.

The small area of the anode keeps the capacitance very small. Since the active volume of the diode is enlarged by adding more electrodes with the same anode area, the input capacitance is independent of detector area. This is important because the dominant noise source in silicon X-ray spectroscopy is voltage noise, which is proportional to the total input capacitance and increases at short shaping times. The SDD, with its low capacitance, has lower noise, particularly at very short shaping times.

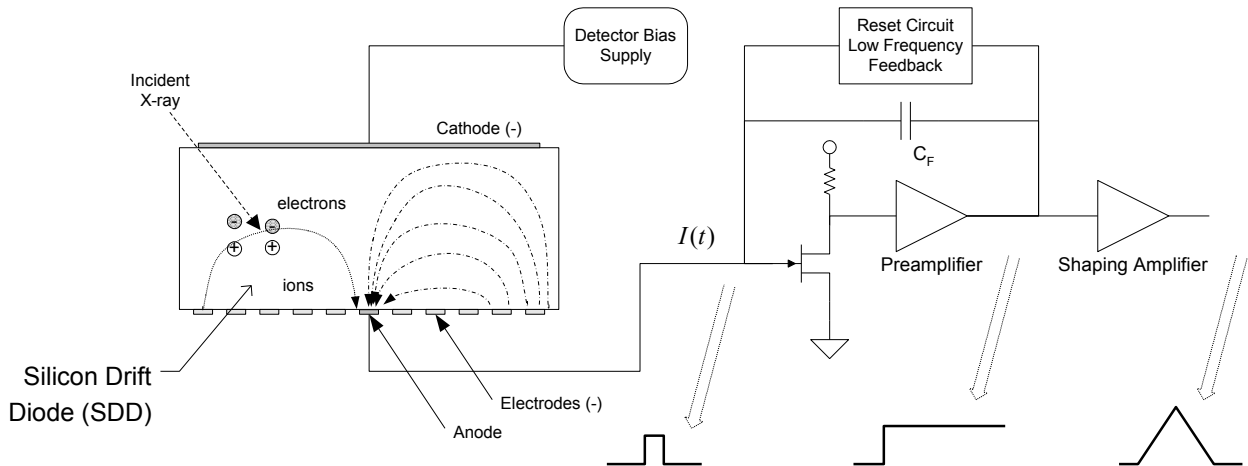
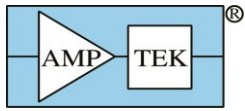

Figure 6. Sketch illustrating the operation of a silicon drift diode.



Is the SDD a new technology?

The SDD is actually a very mature technology. The SDD was introduced in 1984 by Gatti and Rehak, in a paper which presented by the concept and experimental results. [1]. The SDD was seen as the solid state equivalent of gas drift chambers then in use and was initially proposed to measure the spatial location of interaction (derived from the drift time). In that first paper, Gatti and Rehak observed that the capacitance is independent of area, so “very large area radiation detectors or photodiodes using this principle may have much improved noise performance when compared to traditional diode detectors”.

There was much research carried out on the SDDs in the mid to late 1980s. The first circular SDD, optimized for energy rather than position measurements, was described in 1985 by Rehak and Gatti et. al. [2]. The early drift detectors used drift rings on both sides to produce the radial field. In 1987, Kemmer [3] introduced a design using a planar contact on one side with drift rings on the opposite side. This was much easier to fabricate and provided a thin, unstructured dead layer on the entrance side, which is quite important for X-ray spectroscopy. Even today, 25 years after the first SDDs were fabricated, research continues [5, 6, 7, 8]. SDDs optimized for X-ray spectroscopy have been commercially available for several years. They are a well established, mature technology.

What is unique about Amptek’s SDD?

Amptek, Inc. is the leading OEM supplier of detectors for energy dispersive X-ray fluorescence (EDXRF). Amptek’s thermoelectrically cooled detectors and electronics are very widely used in portable and handheld EDXRF instruments. In many ways, Amptek’s products allowed the widespread use and large market for portable EDXRF [9]. Amptek’s detectors combine high performance with low cost and quantity production, making them appropriate for OEM uses.

Amptek’s SDD was optimized for this market, combining high performance (large area, good resolution) with low cost and large quantities. Amptek’s SDD was also optimized to be compatible with Amptek’s existing base of preamplifiers, signal processors, etc. Amptek’s requirements were unique, making it necessary to develop a custom SDD. Amptek used the extensive literature on SDDs. We also consulted with the detector development group at the Brookhaven National Laboratory, obtaining very useful advice from P. Rehak, V. Radeka, W. Chen, G. De Geronimo, and their team. We simulated several different device designs and fabrication parameters, using commercially available device simulation software from Silvaco. Figure 7 is the result of one such simulation, showing the electrostatic field distribution with a possible SDD design. Amptek’s SDD is a custom design, optimized for Amptek’s product family, based on the published results of this mature technology.

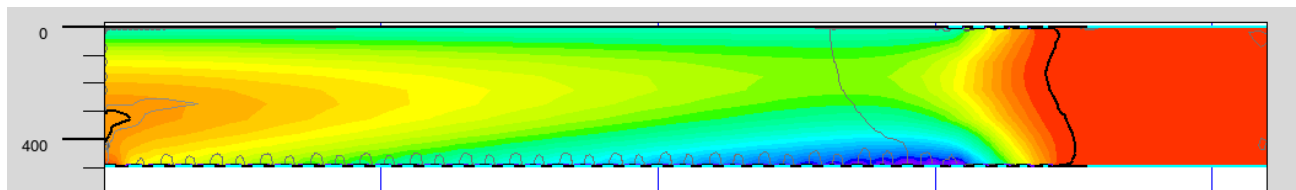

Figure 7. Simulation result for one SDD configuration, obtained using the Silvaco Atlas tools, showing a radial profile of the detector. The center of the detector (signal anode) is at the left. The entrance contact is seen at the top, with drift rings at the bottom. The colors depict the electrostatic potential which guides the drifting electrons to the anode.

Is there a very long charge collection time with a drift diode?

Although the charges drift for a very long time, many microseconds, the risetime out of the preamp is still very fast. This is because the final drift electrode is a virtual ground. Although electrons are moving for the full drift period, yielding a current through the diode for the full drift period, this electrode essentially shields the anode. It is only the drift motion past this final electrode that induces the signal current into the anode.

However, as the carriers drift towards the anode, the charge cloud grows by diffusion. This causes the collection time to increase for interactions at large distances from the anode, causing the preamplifier risetime to vary. For the SDD at a typical bias voltage, the preamp risetime vary from 0.05 to 0.25 μ s. Amptek recommends the flat top of the shaped pulse be kept at 0.25 μ s or larger to avoid ballistic deficit. If the flat top duration is too short, the photopeak shapes in the spectrum will be larger than expected from noise and Fano effects and will be non-Gaussian.

What are the different noise sources in Si-PIN and SDD detectors?

Figure 8 is an equivalent circuit of an X-ray detection system, applicable to both Si-PIN and SDD detectors (and in fact applicable to many radiation detectors). The detector is represented as a signal source. In parallel with the detector is a current noise generator. In Amptek’s systems, this is due entirely to shot noise produced by the detector’s leakage current. In other systems, this may also include thermal noise due to the feedback and bias detector and other terms, but reset type preamps eliminate these contributions. In series with the detector is a voltage noise generator. In Amptek’s systems, this is due to thermal noise from the channel of the input FET and to pink or 1/f voltage noise arising in the FET and the detector.

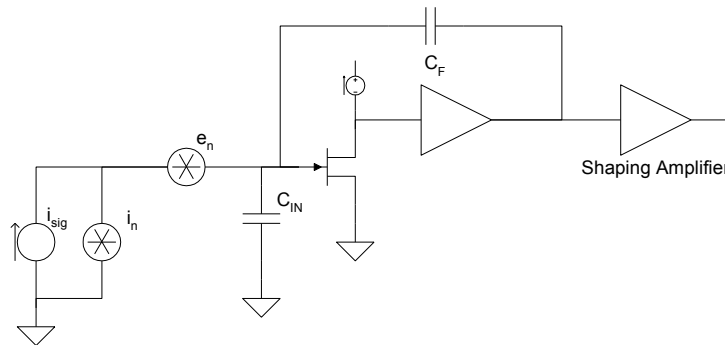

Figure 8. Noise equivalent circuit for an X-ray detector using any type of photodiode.

The equation below gives the electronic noise charge due to these noise generators, where the shaping amplifier is one of Amptek’s digital pulse processors. The current noise increases with leakage and with the peaking time. The 1/f noise is independent of peaking time but proportional to input capacitance. The thermal noise of the FET decreases with peaking time and is also proportional to the input capacitance.

$$ENC^2 = (2qI_{leak}) \left(\frac{2}{3} \tau_{peak} \right) + (e^2_{pink} C_{in}^2) + \left(\frac{4kT}{(2/3)g_m} \right) \left(C_{in}^2 \frac{2}{\tau_{peak}} \right)$$

The total resolution for an X-ray photopeak is due to the electronic noise and also to Fano broadening, arising from statistical fluctuations in the radiation interaction and charge production process. The Fano broadening adds in quadrature with the electronic noise, i.e. total broadening is the square root of the sum of the squares. Fano broadening is independent of peaking time and scales as the square root of the energy.

The importance of these contributions can be seen in Figure 9, showing data for a typical 13 mm² x 500 μ m Si-PIN operating at 220 K on a Peltier cooler in an Amptek XR-100 with a PX4 digital pulse processor. The black dots represent the total resolution measured using 5.9 keV X-rays from an ⁵⁵Fe radioactive source. The Fano term was removed, giving the electronic noise charge, the black curve. These data were fit to the peaking time dependence of the equation above to give the series, parallel, and 1/f contributions. The parallel noise, due to leakage current, is negligible at all shaping times measured (this is true at 220 K but not at 250 K). The series noise dominates performance at peaking times less than 9 μ sec, so at the

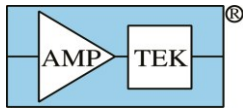

short shaping times needed to operate at high count rates. The $1/f$ noise dominates at the noise corner, where the series and parallel are equal.

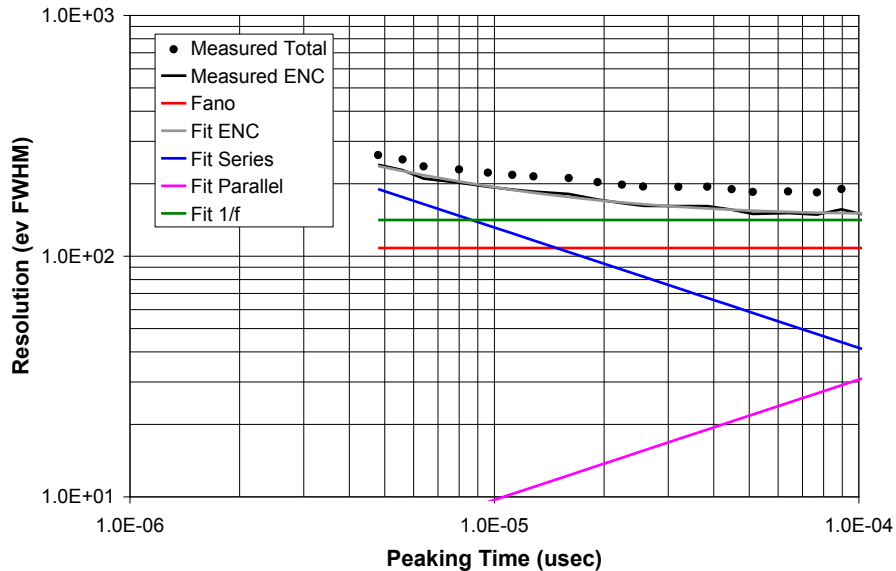

Figure 9. Plot showing the noise components versus shaping time for a typical Amptek 13 mm² x 500µm Si-PIN diode.

The blue and green curves are both proportional to the input capacitance, so are dramatically reduced in the SDD relative to the Si-PIN. This reduces the noise at the optimum, and also reduces the optimum peaking time, permitting operation at much higher count rates. This is the key advantage of the SDD.

- ¹ E. Gatti, P. Rehak, "Semiconductor drift chamber – an application of a novel charge transport scheme", Nucl. Instrum. Meth. 225, pp 608-614 (1984).
- ² P. Rehak, E. Gatti, A. Longoni, J. Kemmer, P. Holl, R. Klanner, G. Lutz, W. Wylie, "Semiconductor drift chambers for position and energy measurements", Nucl. Instrum. Meth. A235, pp 224-234 (1985).
- ³ J. Kemmer, G. Lutz, E. Bebeau, U. Prectel, W. Welser, "Low capacity drift diode", Nucl. Instrum. Meth. A253, pp 378-381 (1987).
- ⁴ Unless otherwise noted, the "resolution" is specified at the Mn K_α line, 5.9 keV.
- ⁵ G.A. Carini, W. Chen, et. al, "Performance of a thin-window silicon drift detector X-ray fluorescence spectrometer", IEEE. Trans. Nucl. Sci., Vol 56, No. 2, pp 2843-2849 (2009)
- ⁶ G. Zampa, A. Rashevsky, A. Vacchi, "The X-ray spectroscopic performance of a very large area silicon drift detector", IEEE. Trans. Nucl. Sci., Vol 56, No. 3, pp 832-835 (2009)
- ⁷ P. Rehak, W. Chen, et. al., "Comparison of two different methods to produce thin-window silicon drift detectors", Proc. IEEE Nucl. Sci. Symp., pp 1777-1782 (2009)
- ⁸ C. Fiorini, A. Gola, et. al. "A CMOS pulsed-reset preamplifier for silicon drift detectors with on-chip JFET", Proc. IEEE Nucl. Sci. Symp., pp 2519-2521 (2007)
- ⁹ T. Pantazis, J. Pantazis, A. Huber, R. Redus, "The historical development of the thermoelectrically cooled X-ray detector and its impact on the portable and hand-held XRF industries", X-ray Spectrometry, Vol. 39, No. 2, pp 90-97, (Oct 2009)