

User Manual

MKS TYPE 649B (ROHS COMPLIANT) PRESSURE CONTROLLER WITH INTEGRAL MASS FLOW METER



Copyright © 2023 by MKS Instruments, Inc.

All rights reserved. No part of this work may be reproduced or transmitted in any form or by any means, electronic or mechanical, including photocopying and recording, or by any information storage or retrieval system, except as may be expressly permitted in writing by MKS Instruments, Inc.

mksinst™ is a trademark of MKS Instruments, Inc.

Baratron® is a registered trademark of MKS Instruments, Inc., Andover, MA

Swagelok®, VCO®, and VCR® are registered trademarks of Swagelok Company, Solon, OH

Inconel® is a registered trademark of Inco Alloys, Inc. Huntington, WV

Viton® is registered trademark of DuPont Dow Elastomers, Inc., Wilmington, DE

Kel-F® is a registered trademark of 3M, Minneapolis, MN

Elgiloy® is a registered trademark of Elgiloy Limited Partnership, Elgin, IL

Protected by U. S. Patent 5461913; foreign patents pending.

All other product names herein are used for identification purposes only and are recognized as properties (including trademarks, registered trademarks, and referenced copyrighted materials) of their respective companies.

Table of Contents

List of Figures and Tables	7
1 Warranty	8
2 Safety	9
2.1 Safety Information	9
2.1.1 Symbols Used in This Instruction Manual.....	9
2.1.2 Symbols Found on the Unit.....	10
2.1.3 Safety Procedures and Precautions	11
2.2 Sicherheitshinweise	13
2.2.1 In dieser Betriebsanleitung vorkommende Symbole	13
2.2.2 Erklärung der am Gerät angebrachten Symbole	14
2.2.3 Sicherheitsvorschriften und Vorsichtsmaßnahmen	15
2.3 Informations de Sécurité	17
2.3.1 Symboles utilisés dans ce manuel d'utilisation.....	17
2.3.2 Symboles figurant sur l'unité.....	18
2.3.3 Mesures de sécurité et précautions.....	19
2.4 Medidas de Seguridad	21
2.4.1 Símbolos usados en este manual de instrucciones	21
2.4.2 Símbolos hallados en la unidad.....	22
2.4.3 Procedimientos y precauciones de seguridad.....	23
2.5 安全に関する情報	25
2.5.1 本取扱説明書のマーク	25
2.5.2 本機器のマーク	26

2.5.3	安全対策について	27
2.6	장치 안전 정보.....	29
2.6.1	본 지침 매뉴얼에 사용되는 기호들	29
2.6.2	장치에 표시된 기호들.....	30
2.6.3	안전 절차 및 예방조치.....	31
3	Chapter 3 General Information.....	33
3.1	Introduction.....	33
3.1.1	Design Features of the Integral Mass Flow Meter.....	33
3.1.2	Cleanliness Features	34
3.2	How This Manual is Organized	34
3.2.1	Manual Conventions	35
3.3	Customer Support	35
4	Chapter 4 Installation	36
4.1	How To Unpack the Type 649 Unit.....	36
4.1.1	Opening the Package	36
4.1.2	Unpacking Checklist	36
4.2	Interface Cables	37
4.2.1	Generic Shielded Cable Description.....	37
4.3	Product Location and Requirements.....	38
4.4	Dimensions.....	39
4.4.1	Front and Back Views	39
4.4.2	Side View	41

- 4.4.3 Bottom View41
- 4.5 Dimensions.....42
 - 4.5.1 Fittings.....42
 - 4.5.2 Mounting Hardware.....42
 - 4.5.3 Gas Pressure42
 - 4.5.4 Installing the Unit43
- 4.6 Electrical Information.....43
 - 4.6.1 I/O Connector.....43
- 4.7 Initial Configuration46
- 5 Chapter 5 Overview.....47
 - 5.1 General Information47
 - 5.1.1 Pressure Control Range47
 - 5.1.2 Flow Range.....47
 - 5.1.3 A Typical Control System.....48
 - 5.2 How The 649 Pressure Controller Works48
 - 5.3 Flow Measurement Overview.....49
 - 5.3.1 Flow Path49
 - 5.3.2 Measurement Technique49
 - 5.4 Tuning the 649B Pressure Controller.....50
 - 5.4.1 Proportional Term50
 - 5.4.2 Integral Term.....51
 - 5.4.3 Tuning the 649B Controller51
 - 5.5 Priority of Commands.....54
 - 5.6 Trip Points55

5.6.1	Action of the Trip Points.....	55
5.7	Applications with a Large Differential Pressure	56
5.8	Labels.....	56
6	Chapter 6 Operation.....	57
6.1	How To Check the Pressure Transducer Zero	57
6.2	How To Adjust the Pressure Transducer Span.....	58
6.3	How To Zero the Integral Mass Flow Meter	58
6.4	How To Tune the 649B Controller	59
6.5	How To Adjust the Trip Point Values	59
6.6	How To Select the Trip Point Action	61
6.7	How To Use Trip Points as Error Indicators.....	62
6.8	How To Change the Pressure Output Signal Range	64
7	Chapter 7 Maintenance	66
7.1	General Information	66
7.2	Zero Adjustment.....	66
Appendix	67
Appendix A:	Product Specifications	67
Appendix B:	Model Code Explanation.....	70
Appendix C:	Valve Orifice Selection.....	73
Index	76

List of Figures and Tables

Figure 1: Front View40

Figure 2: Rear View40

Figure 3: Side View.....41

Figure 4: Bottom View42

Figure 5: Downstream Pressure Control43

Figure 6: Top View.....47

Figure 7: Location of Flow Meter Adjustments48

Figure 8: Effects of the Proportional Control Term.....50

Figure 9: Effects of the Integral Control Term51

Figure 10: Controller Response with Initial P Term and I Term Values52

Figure 11: Controller Response with Increased P Term53

Figure 12: Controller Response with Increased I Term.....53

Figure 13: Serial Number Label.....56

Figure 14: Jumper Positions on the Transducer Board.....62

Figure 15: Valve Orifice Index Number74

Table 1: Connector Pin Assignments44

Table 2: - Initial Configuration.....46

Table 3: - Highest Pressure for Zero Adjustment of the Pressure Transducer58

Table 4: - Valve Orific Sizes73

Table 5 - Valve Orifice Index Number74

1 Warranty

MKS Instruments, Inc. (MKS) warrants that for one (1) year from the date of shipment the equipment, which is described above and manufactured by MKS, shall be free from defects in materials and workmanship.

For the period commencing with the date of shipment of this equipment and ending one (1) year later, MKS will, at its option, either repair or replace any part which is defective in materials or workmanship without charge to the purchaser. The foregoing shall constitute the exclusive and sole remedy of the purchaser for any breach of MKS of this warranty.

The purchaser, before returning any equipment covered by this warranty, which is asserted to be defective by the purchaser, shall make specific written arrangements with respect to the responsibility for shipping the equipment and handling any other incidental charges with the MKS Sales Representative or distributor from which the equipment was purchased or, in the case of a direct purchase from MKS, with the MKS home office in Andover, Massachusetts, USA.

This warranty does not apply to any equipment which has not been installed and used in accordance with the specifications recommended by MKS for the proper and normal use of the equipment. MKS shall not be liable under any circumstances for indirect, special, consequential, or incidental damages in connection with, or arising out of, the sale, performance, or use of the equipment covered by this warranty.

MKS recommends that all MKS pressure and flow products be calibrated periodically (typically) every 6 to 12 months) to ensure accurate readings. When a product is returned to MKS for this periodic re-calibration it is considered normal preventative maintenance not covered by any warranty.

THIS WARRANTY IS IN LIEU OF ALL OTHER RELEVANT WARRANTIES, EXPRESSED OR IMPLIED, INCLUDING THE IMPLIED WARRANTY OF MERCHANTABILITY AND THE IMPLIED WARRANTY OF FITNESS FOR A PARTICULAR PURPOSE, AND ANY WARRANTY AGAINST INFRINGEMENT OF ANY PATENT.

2 Safety

2.1 Safety Information

The following general safety precautions must be observed during all phases of operation of this instrument. Failure to comply with these precautions or with specific warnings elsewhere in this manual violates safety standards of intended use of the instrument and may impair the protection provided by the equipment. MKS Instruments, Inc. assumes no liability for the customer's failure to comply with these requirements.

2.1.1 Symbols Used in This Instruction Manual

The following are definitions of WARNING, CAUTION, and NOTE messages used throughout the manual.

NOTE

The NOTE sign denotes important information. It calls attention to a procedure, practice, condition, or the like, which is essential to highlight.

CAUTION

The CAUTION sign denotes a hazard. It calls attention to an operating procedure, practice, or the like, which, if not correctly performed or adhered to, could result in damage to or destruction of all or part of the product.

WARNING













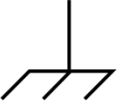

The WARNING sign denotes a hazard. It calls attention to a procedure, practice, condition, or the like, which, if not correctly performed or adhered to, could result in injury to personnel.

DANGER

The DANGER sign Indicates an imminently hazardous situation that, if not avoided, will result in death or serious injury.

2.1.2 Symbols Found on the Unit

The following table describes symbols that may be found on the unit.

 <p>ON (Supply) IEC 417, No. 5007</p>	 <p>OFF (Supply) IEC 417, No. 5008</p>	 <p>Earth (ground) IEC 417, No. 5017</p>	 <p>Protective earth (ground) IEC 417, No. 5019</p>
 <p>Frame or Chassis IEC 417, No. 5020</p>	 <p>Equipotentiality IEC 417, No. 5021</p>	 <p>Direct current IEC 417, No. 5031</p>	 <p>Alternating current IEC 417, No. 5032</p>
 <p>Both direct and alternating current IEC 417, No. 5019</p>	 <p>Class II equipment IEC 417, No. 5172-a</p>	 <p>Three phase alternating current IEC 617-2, No. 020206</p>	
 <p>Caution refers to accompanying documents ISO 3864, No. B.3 1</p>	 <p>Caution risk of electric shock ISO 3864, No. B.3 6</p>	 <p>Caution hot surface IEC 417, No. 5021</p>	

2.1.3 Safety Procedures and Precautions

Observe the following general safety precautions during all phase of operation of this instrument. Failure to comply with these precautions or with specific warnings elsewhere in this manual violates safety standards of intended use of the instrument and may impair the protection provided by the equipment. MKS Instruments, Inc. assumes no liability for the customer's failure to comply with these requirements.

DO NOT SUBSTITUTE PARTS OR MODIFY INSTRUMENT

Do not install substitute parts or perform any unauthorized modification to the instrument. Return the instrument to an MKS Calibration and Service Center for service and repair to ensure that all safety features are maintained.

SERVICE BY QUALIFIED PERSONNEL ONLY

Operating personnel must not remove instrument covers. Component replacement and internal adjustments must be made by qualified service personnel only.

KEEP AWAY FROM LIVE CIRCUITS

Do not replace components with power cable connected. Under certain conditions, dangerous voltages may exist even with the power cable removed. To avoid injuries, always disconnect power and discharge circuits before touching them.

USE CAUTION WHEN OPERATING WITH HAZARDOUS MATERIALS

If hazardous materials are used, users must take responsibility to observe the proper safety precautions, completely purge the instrument when necessary, and ensure that the material used is compatible with sealing materials.

PURGE THE INSTRUMENT

After installing the unit, or before its removal from a system, be sure to purge the unit completely with a clean dry gas to eliminate all traces of the previously used flow material.

USE PROPER PROCEDURES WHEN PURGING

This instrument must be purged under a ventilation hood, and gloves must be worn to protect personnel. To purge this instrument properly, it must be purged in both the horizontal base down and horizontal base up configurations as defined in SEM spec. Device has trapped volume in pressure sensor where gas which is higher than air but still hazardous can accumulate.

DO NOT OPERATE IN AN EXPLOSIVE ENVIRONMENT

To avoid explosion, do not operate this product in an explosive environment unless it has been specifically certified for such operation.

USE PROPER FITTINGS AND TIGHTENING PROCEDURES

All instrument fittings must be consistent with instrument specifications, and compatible with the intended use of the instrument. Assemble and tighten fittings according to manufacturer's directions.

CHECK FOR LEAK-TIGHT FITTINGS

Before proceeding to instrument setup, carefully check all plumbing connections to the instrument to ensure leak-tight installation.

OPERATE AT SAFE INLET PRESSURES

This unit should never be operated at pressures higher than the rated maximum pressure (refer to the product specifications for the maximum allowable pressure).

INSTALL A SUITABLE BURST DISC

When operating from a pressurized gas source, a suitable burst disc should be installed in the vacuum system to prevent system explosion should the system pressure rise.

KEEP THE UNIT FREE OF CONTAMINANTS

Do not allow contaminants of any kind to enter the unit before or during use. Contamination such as dust, dirt, lint, glass chips, and metal chips may permanently damage the unit.

ALLOW PROPER WARM UP TIME FOR TEMPERATURE-CONTROLLED UNITS

Temperature-controlled unit will only meet specifications when sufficient time is allowed for the unit to meet, and stabilize at, the designed operating temperature. Do not zero or calibrate the unit until the warmup is complete.

2.2 Sicherheitshinweise für das Massenflussgerät

2.2.1 In dieser Betriebsanleitung vorkommende Symbole ual

Bedeutung der mit WARNUNG!, VORSICHT! und HINWEIS gekennzeichneten Absätze in dieser Betriebsanleitung.

HINWEIS

Das Symbol HINWEIS macht auf wichtige Informationen bezüglich eines Arbeitsablaufs, einer Arbeitsweise, eines Zustands oder einer sonstige Gegebenheit aufmerksam.

VORSICHT

Das Symbol VORSICHT! weist auf eine Gefahr für das Gerät hin. Es macht auf einen Bedienungsablauf, eine Arbeitsweise oder eine sonstige Gegebenheit aufmerksam, deren unsachgemäße Ausführung bzw. ungenügende Berücksichtigung zu einer Beschädigung oder Zerstörung des Gerätes oder von Teilen des Gerätes führen kann.

WARNUNG!











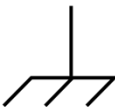

Das Symbol WARNUNG! weist auf eine Gefahr für das Bedienpersonal hin. Es macht auf einen Arbeitsablauf, eine Arbeitsweise, einen Zustand oder eine sonstige Gegebenheit aufmerksam, deren unsachgemäße Ausführung bzw. ungenügende Berücksichtigung zu Verletzungen führen kann.

GEFAHR

Das DANGER-Zeichen weist auf eine unmittelbar gefährliche Situation hin, die, wenn sie nicht vermieden wird, zum Tod oder zu schweren Verletzungen führen wird.

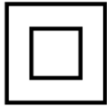
2.2.2 Erklärung der am Gerät angebrachten Symbole

Nachstehender Tabelle sind die Bedeutungen der Symbole zu entnehmen, die am Gerät angebracht sein können.

 <p>Ein (Energie) IEC 417, No.5007</p>	 <p>Aus (Energie)) IEC 417, No.5008</p>	 <p>Erdanschluss IEC 417, No.5017</p>	 <p>Schutzleiteranschluss IEC 417, No.5019</p>
 <p>Masseanschluss IEC 417, No.5020</p>	 <p>Aquipotentialanschluss IEC 417, No.5021</p>	 <p>Gleichstrom IEC 417, No.5031</p>	 <p>Wechselstrom IEC 417, No.5032</p>
 <p>Gleich- oder Wechselstrom IEC 417, No.5019</p>	 <p>Durchgängige doppelte oder verstärkte Isolierung IEC 417, No.5172-a</p>	 <p>Dreileiter-Wechselstrom (Drehstrom) IEC 617-2, No.020206</p>	
 <p>Warnung vor einer Gefahrenstelle (Achtung, Dokumentation beachten) ISO 3864, No.B.3 1</p>	 <p>Warnung vor gefährlicher elektrischer Spannung ISO 3864, No.B.3 6</p>	 <p>Höhere Temperatur an leicht zugänglichen Teilen IEC 417, No.5021</p>	

2.2.3 Sicherheitsvorschriften und Vorsichtsmaßnahmen

Folgende allgemeine Sicherheitsvorschriften sind während allen Betriebsphasen dieses Gerätes zu befolgen. Eine Missachtung der Sicherheitsvorschriften und sonstiger Warnhinweise in dieser Betriebsanleitung verletzt die für dieses Gerät und seine Bedienung geltenden Sicherheitsstandards, und kann die Schutzvorrichtungen an diesem Gerät wirkungslos machen. MKS Instruments, Inc. haftet nicht für Missachtung dieser Sicherheitsvorschriften seitens des Kunden.

NIEMALS TEILE AUSTAUSCHEN ODER ÄNDERUNGEN AM GERÄT VORNEHMEN!

Ersetzen Sie keine Teile mit baugleichen oder ähnlichen Teilen, und nehmen Sie keine eigenmächtigen Änderungen am Gerät vor. Schicken Sie das Gerät zwecks Wartung und Reparatur an den MKS- Kalibrierungs- und -Kundendienst ein. Nur so wird sichergestellt, dass alle Schutzvorrichtungen voll funktionsfähig bleiben.

WARTUNG NUR DURCH QUALIFIZIERTE FACHLEUTE!

Das Auswechseln von Komponenten und das Vornehmen von internen Einstellungen darf nur von qualifizierten Fachleuten durchgeführt werden, niemals vom Bedienpersonal.

VORSICHT VOR STROMFÜHRENDEN LEITUNGEN!

Ersetzen Sie keine Komponente von Geräten, die an Netzstrom angeschlossen sind. Unter Umständen kann gefährliche Spannung auch dann bestehen, wenn das Netzanschlusskabel von der Stromversorgung entfernt wurde. Um Verletzungen vorzubeugen sollten zuerst alle Geräte von der Stromversorgung getrennt und alle Stromkreisläufe entladen werden.

VORSICHT BEIM ARBEITEN MIT GEFÄHRLICHEN STOFFEN!

Wenn gefährliche Stoffe verwendet werden, muss der Bediener die entsprechenden Sicherheitsvorschriften genauestens einhalten, das Gerät, falls erforderlich, vollständig spülen, sowie sicherstellen, dass der Gefahrstoff die am Gerät verwendeten Materialien, insbesondere Dichtungen, nicht angreift.

SPÜLEN DES GERÄTES MIT GAS!

Nach dem Installieren oder vor dem Ausbau aus einem System muss das Gerät unter Einsatz eines reinen Trockengases vollständig gespült werden, um alle Rückstände des Vorgängermediums zu entfernen.

ANWEISUNGEN ZUM SPÜLEN DES GERÄTES

Das Gerät darf nur unter einer Ablufthaube gespült werden. Schutzhandschuhe sind zu tragen.

GERÄT NICHT ZUSAMMEN MIT EXPLOSIVEN STOFFEN, GASEN ODER DÄMPFEN BENUTZEN!

Um der Gefahr einer Explosion vorzubeugen, darf dieses Gerät niemals zusammen mit (oder in der Nähe von) explosiven Stoffen aller Art eingesetzt werden, sofern es nicht ausdrücklich für diesen Zweck zugelassen ist.

ANWEISUNGEN ZUM INSTALLIEREN DER ARMATUREN!

Alle Anschlussstücke und Armaturenteile müssen mit der Gerätespezifikation übereinstimmen, und mit dem geplanten Einsatz des Gerätes kompatibel sein. Der Einbau, insbesondere das Anziehen und Abdichten, muss gemäß den Anweisungen des Herstellers vorgenommen werden.

VERBINDUNGEN AUF UNDICHTIGKEITEN PRÜFEN!

Überprüfen Sie sorgfältig alle Verbindungen der Vakuumkomponenten auf undichte Stellen.

GERÄT NUR UNTER ZULÄSSIGEN ANSCHLUSSDRÜCKEN BETREIBEN!

Betreiben Sie das Gerät niemals unter Drücken, die den maximal zulässigen Druck (siehe Produktspezifikationen) übersteigen.

GEEIGNETE BERSTSCHEIBE INSTALLIEREN!

Wenn mit einer unter Druck stehenden Gasquelle gearbeitet wird, sollte eine geeignete Berstscheibe in das Vakuumsystem installiert werden, um eine Explosionsgefahr aufgrund von steigendem Systemdruck zu vermeiden.

VERUNREINIGUNGEN IM GERÄT VERMEIDEN!

Stellen Sie sicher, dass Verunreinigungen jeglicher Art weder vor dem Einsatz noch während des Betriebs in das Instrumenteninnere gelangen können. Staub- und Schmutzpartikel, Glassplitter oder Metallspäne können das Gerät dauerhaft beschädigen oder Prozess- und Messwerte verfälschen.

BEI GERÄTEN MIT TEMPERATURKONTROLLE KORREKTE ANWÄRMZEIT EINHALTEN!

Temperaturkontrollierte Geräte arbeiten nur dann gemäß ihrer Spezifikation, wenn genügend Zeit zum Erreichen und Stabilisieren der Betriebstemperatur eingeräumt wird. Kalibrierungen und Nulleinstellungen sollten daher nur nach Abschluss des Anwärmvorgangs durchgeführt werden.

2.3 Informations de sécurité pour appareils de mesure/contrôle de débit massique

2.3.1 Symboles utilisés dans ce manuel d'utilisation

Définitions des indications AVERTISSEMENT, ATTENTION, et REMARQUE utilisées dans ce manuel.

REMARQUE

L'indication REMARQUE signale une information importante. Elle attire l'attention sur une procédure, une pratique, une condition, ou toute autre situation, présentant un intérêt particulier.

ATTENTION

L'indication ATTENTION signale un danger pour l'appareil. Elle attire l'attention sur une procédure d'exploitation, une pratique, ou toute autre situation, présentant un risque de dégât ou de destruction partielle ou totale du produit, en cas d'exécution incorrecte ou de non-respect des consignes.

AVERTISSEMENT













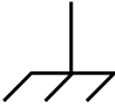

L'indication AVERTISSEMENT signale un danger pour le personnel. Elle attire l'attention sur une procédure, une pratique, une condition, ou toute autre situation présentant un risque d'accident pour le personnel, en cas d'exécution incorrecte ou de non-respect des consignes.

DANGER

Le panneau DANGER indique une situation dangereuse imminente qui, si elle n'est pas évitée, entraînera la mort ou des blessures graves.

2.3.2 Symboles figurant sur l'unité

Le tableau suivant décrit les symboles pouvant apparaître sur l'unité.

			
Marche (sous tension) IEC 417, No.5007	Arrêt (hors tension) IEC 417, No.5008	Terre (masse) IEC 417, No.5017	Terre de protection (masse) IEC 417, No.5019
			
Masse IEC 417, No.5020	quipotentialité IEC 417, No.5021	Courant continu IEC 417, No.5031	Courant alternatif IEC 417, No.5032
			
Courant continu et alternatif IEC 417, No.5019	Matériel de classe II IEC 417, No.5172-a	Courant alternatif triphase IEC 617-2, No.020206	
			
Attention : se reporter à la documentation ISO 3864, No.B.3 1	Attention : risque de choc électrique ISO 3864, No.B.3 6	Attention : surface brûlante IEC 417, No.5021	

2.3.3 Mesures de sécurité et précautions

Observer les précautions générales de sécurité suivantes pendant toutes les phases d'exploitation de cet appareil. Le non-respect de ces précautions ou des avertissements du manuel constitue une violation des normes de sécurité relatives à l'utilisation de l'appareil et peut compromettre la protection assurée par l'appareil. MKS Instruments, Inc. rejette toute responsabilité en cas de non-respect des consignes par les clients.

PAS DE REMPLACEMENT DE PIÈCES OU DE MODIFICATION DE L'APPAREIL

Ne pas installer de pièces de remplacement ni effectuer des modifications non autorisées sur l'appareil. Renvoyer l'appareil à un centre de service et de calibrage MKS pour tout dépannage ou réparation afin de garantir l'intégrité des dispositifs de sécurité.

DÉPANNAGE UNIQUEMENT PAR DU PERSONNEL QUALIFIÉ

Le personnel d'exploitation ne doit pas essayer de sortir les composants du boîtier ou faire des réglages internes. Le dépannage est réservé au personnel qualifié.

ÉLOIGNEMENT DES CIRCUITS SOUS-TENSION

Ne pas remplacer de composants lorsqu'un câble d'alimentation est branché. Dans certaines conditions, des tensions dangereuses peuvent être présentes même après le retrait du câble d'alimentation. Pour éliminer tout risque de blessure, procéder toujours à la déconnexion et décharger les circuits avant tout contact physique.

PRÉCAUTION EN CAS D'UTILISATION AVEC DES PRODUITS DANGEREUX

Si des produits dangereux sont utilisés, l'utilisateur est responsable du respect des mesures de sécurité appropriées, de la purge complète de l'appareil quand elle s'avère nécessaire, et doit s'assurer que les produits utilisés sont compatibles avec les matériaux d'étanchéité.

PURGE DE L'APPAREIL

Après l'installation de l'unité, ou avant son retrait d'un système, purger l'unité complètement avec un gaz propre et sec afin d'éliminer toute trace du produit de flux utilisé précédemment.

UTILISATION DES PROCÉDURES APPROPRIÉES POUR LA PURGE

Cet appareil doit être purgé sous une hotte de ventilation. Le personnel doit porter des gants de protection.

PAS D'EXPLOITATION DANS UN ENVIRONNEMENT EXPLOSIF

Pour éviter toute explosion, ne pas utiliser cet appareil dans un environnement explosif, sauf en cas d'homologation spécifique pour une telle exploitation.

UTILISATION D'ÉQUIPEMENTS ET PROCÉDURES DE SERRAGE APPROPRIÉS

Tous les équipements de l'appareil doivent être conformes à ses spécifications, et compatibles avec l'utilisation prévue de l'appareil. Assembler et serrer les équipements conformément aux directives du fabricant.

VÉRIFICATION DE L'ÉTANCHÉITÉ DES CONNEXIONS

Vérifier attentivement toutes les connexions des composants pour le vide afin de garantir l'étanchéité de l'installation.

EXPLOITATION AVEC DES PRESSIONS D'ENTRÉE NON DANGEREUSES

Ne jamais utiliser des pressions supérieures à la pression nominale maximum (se reporter aux spécifications de l'unité pour la pression maximum admissible).

INSTALLATION D'UN DISQUE D'ÉCHAPPEMENT ADAPTÉ

En cas d'exploitation avec une source de gaz pressurisé, installer un disque d'échappement adapté dans le système à vide, afin d'éviter une explosion du système en cas d'augmentation de la pression.

MAINTIEN DE L'UNITÉ À L'ABRI DES CONTAMINATIONS

Ne pas laisser des produits contaminants pénétrer dans l'unité avant ou pendant l'utilisation. Des produits contaminants tels que des poussières et des fragments de tissu, de verre et de métal peuvent endommager l'unité de manière permanente.

RESPECT DU TEMPS D'ÉCHAUFFEMENT APPROPRIÉ POUR LES UNITÉS À RÉGULATION DE TEMPÉRATURE

Les unités à régulation de température sont conformes à leurs spécifications uniquement quand on leur laisse un temps suffisant pour atteindre d'une manière stable la température d'exploitation. Ne pas remettre à zéro ou calibrer l'unité tant que l'échauffement n'est pas terminé.

2.4 Medidas de seguridad del dispositivo de flujo de masa

2.4.1 Símbolos usados en este manual de instrucciones

Definiciones de los mensajes de advertencia, precaución y de las notas usados en el manual.

NOTA

El símbolo de notas indica información de importancia. Este símbolo pone de relieve un procedimiento, práctica o condición cuyo conocimiento es esencial destacar.

PRECAUCIÓN

El símbolo de precaución indica la posibilidad de producir daños al equipo. Pone de relieve un procedimiento operativo, práctica, etc. que en caso de no realizarse o cumplirse correctamente puede causar daños o la destrucción total o parcial del equipo.

ADVERTENCIA

El símbolo de advertencia indica la posibilidad de que se produzcan daños personales. Pone de relieve un procedimiento, práctica, estado, etc. que en caso de no realizarse o cumplirse correctamente puede causar daños personales.

PELIGRO

La señal de PELIGRO indica una situación inminentemente peligrosa que, si no se evita, resultará en la muerte o lesiones graves.

2.4.2 Símbolos hallados en la unidad

La tabla siguiente contiene los símbolos que puede hallar en la unidad.

 Encendido (alimentación eléctrica) IEC 417, N° 5007	 Apagado (alimentación eléctrica) IEC 417, N° 5008	 Puesta a tierra IEC 417, N° 5017	 Protección a tierra IEC 417, N° 5019
 Caja o chasis IEC 417, N° 5020	 Equipotencialidad IEC 417, N° 5021	 Corriente continua IEC 417, N° 5031	 Corriente alterna IEC 417, N° 5032
 Corriente continua y alterna IEC 417, N° 5019	 Equipo de clase II IEC 417, N° 5172-a	 Corriente alterna trifásica IEC 617-2, N° 020206	
 Precaución. Consulte los documentos adjuntos ISO 3864, N° B.3 1	 Precaución. Riesgo de descarga eléctrica ISO 3864, N° B.3 6	 Precaución. Superficie caliente IEC 417, N° 5021	

2.4.3 Procedimientos y precauciones de seguridad

Las medidas generales de seguridad descritas a continuación deben observarse durante todas las etapas de funcionamiento del instrumento. La falta de cumplimiento de dichas medidas de seguridad o de las advertencias específicas a las que se hace referencia en otras partes de este manual, constituye una violación de las normas de seguridad establecidas para el uso previsto del instrumento y podría anular la protección proporcionada por el equipo. Si el cliente no cumple dichas precauciones y advertencias, MKS Instruments, Inc. no asume responsabilidad legal alguna.

NO UTILICE PIEZAS NO ORIGINALES O MODIFIQUE EL INSTRUMENTO

No instale piezas que no sean originales ni modifique el instrumento sin autorización. Para asegurar el correcto funcionamiento de todos los dispositivos de seguridad, envíe el instrumento al Centro de servicio y calibración de MKS toda vez que sea necesario repararlo o efectuar tareas de mantenimiento.

LAS REPARACIONES DEBEN SER EFECTUADAS ÚNICAMENTE POR TÉCNICOS AUTORIZADOS

Los operarios no deben retirar las tapas del instrumento. El reemplazo de los componentes y las tareas de ajuste deben ser realizadas únicamente por personal autorizado.

MANTÉNGASE ALEJADO DE LOS CIRCUITOS ACTIVOS

No reemplace componentes con el cable de alimentación eléctrica conectado. En algunos casos, puede haber presente alto voltaje aun con el cable de alimentación eléctrica desconectado. Para evitar lesiones personales, desconecte siempre el cable y descargue los circuitos antes de entrar en contacto con los mismos.

TENGA CUIDADO CUANDO TRABAJE CON MATERIALES TÓXICOS

Cuando se utilicen materiales tóxicos, es responsabilidad de los operarios tomar las medidas de seguridad correspondientes, purgar totalmente el instrumento cuando sea necesario y comprobar que el material utilizado sea compatible con los materiales de sellado.

PURGUE EL INSTRUMENTO

Una vez instalada la unidad o antes de retirarla del sistema, purgue completamente la unidad con gas limpio y seco para eliminar todo resto de la sustancia líquida empleada anteriormente.

USE PROCEDIMIENTOS ADECUADOS PARA REALIZAR LA PURGA

El instrumento debe purgarse debajo de una campana de ventilación y deben utilizarse guantes protectores.

NO HAGA FUNCIONAR EL INSTRUMENTO EN AMBIENTES CON RIESGO DE EXPLOSIÓN

Para evitar que se produzcan explosiones, no haga funcionar este instrumento en un ambiente con riesgo de explosiones, excepto cuando el mismo haya sido certificado específicamente para tal uso.

USE ACCESORIOS ADECUADOS Y REALICE CORRECTAMENTE LOS PROCEDIMIENTOS DE AJUSTE

Todos los accesorios del instrumento deben cumplir las especificaciones del mismo y ser compatibles con el uso que se debe dar al instrumento. Arme y ajuste los accesorios de acuerdo con las instrucciones del fabricante.

COMPRUEBE QUE LOS ACCESORIOS SEAN A PRUEBA DE FUGAS

Antes de proceder con la instalación del instrumento, inspeccione cuidadosamente todas las conexiones de las tuberías para comprobar que hayan sido instaladas a prueba de fugas.

HAGA FUNCIONAR EL INSTRUMENTO CON PRESIONES DE ENTRADA SEGURAS

No haga funcionar nunca el instrumento con presiones superiores a la máxima presión nominal (en las especificaciones del instrumento hallará la presión máxima permitida).

INSTALE UNA CÁPSULA DE SEGURIDAD ADECUADA

Cuando el instrumento funcione con una fuente de gas presurizado, instale una cápsula de seguridad adecuada en el sistema de vacío para evitar que se produzcan explosiones cuando suba la presión del sistema.

MANTENGA LA UNIDAD LIBRE DE CONTAMINANTES

No permita el ingreso de contaminantes en la unidad antes o durante su uso. Los productos contaminantes tales como polvo, suciedad, pelusa, lascas de vidrio o virutas de metal pueden dañar irreparablemente la unidad.

CALIENTE ADECUADAMENTE LAS UNIDADES CONTROLADAS POR MEDIO DE TEMPERATURA

Las unidades controladas por medio de temperatura funcionarán de acuerdo con las especificaciones sólo cuando se las caliente durante el tiempo suficiente para permitir que lleguen y se establezcan a la temperatura de operación indicada. No calibre la unidad y no la ponga en cero hasta que finalice el procedimiento de calentamiento.

2.5 マスフロー機器の安全に関する情報

2.5.1 この取扱説明書で使用されている記号

本マニュアルでは警告、注意、ポイントのマークを用いて重要な事項を記載しています。

ポイント

この表示は手順や使用方法、条件などに関する重要な情報が記載されていることを示しています。必ずお読みください。

注意

この表示を無視して誤った取り扱い(手順や使用方法など)をすると、製品が損傷する可能性が想定される内容を示しています。必ずお読みください。

警告

この表示を無視して誤った取り扱い(手順や使用方法、条件など)をすると、人が重傷を負う可能性が想定される内容を示しています。必ずお読みください。

危険

危険記号は、回避しないと死亡または重傷を負う差し迫った危険な状況を示します。

2.5.2 本機器のマーク

以下の表では、本機器に使用されているマークについて説明いたします。

 オン (電源) IEC 417, No. 5007	 オフ (電源) IEC 417, No. 5008	 接地 (アース) IEC 417, No. 5017	 保護接地 (アース) IEC 417, No. 5019
 フレームまたはシャーシ IEC 417, No. 5020	 等電位 IEC 417, No. 5021	 直流 IEC 417, No. 5031	 交流 IEC 417, No. 5032
 直流と交流 IEC 417, No. 5019	 クラス 2 機器 IEC 417, No. 5172-a	 三相交流 IEC 617-2, No. 020206	
 注意 (付属書を参照) ISO 3864, No. B.3 1	 注意 (感電の危険あり) ISO 3864, No. B.3 6	 注意 (表面が熱くなっています) IEC 417, No. 5021	

2.5.3 安全対策について

本機器を使用する際は、必ず以下の安全対策を守ってください。これらの安全対策や本マニュアルの警告を無視すると、機器本来の用途の安全基準を侵害することになり、機器が提供する保護機能が損なわれる可能性があります。MKS Instruments, Inc. は、顧客側の安全対策の不履行に対しては一切責任を負いかねます。

勝手に部品を変えたり、本体を改造しないこと

本機器に代用品を使用したり、不正な改造を加えないでください。すべての安全システムを正しく機能させるための修理やメンテナンスが必要な場合は、本機器を MKS Calibration and Service Center まで戻してください。

修理は必ず専門の修理サービスを利用すること

オペレータは絶対に本機器を分解しないでください。部品の交換や内部の調整は必ず専門の修理サービスを利用してください。

電流が通じている回路から切断すること

電源ケーブルを接続したままで部品を交換しないでください。特定の状況では、電源ケーブルを取り外した状態でも危険な電圧が残っている場合があります。感電などの事故を防ぐため、回路に触れる前に必ず電源から切断し、放電してください。

危険な材料を使用する場合は慎重に機器を使用すること

危険な材料を使用する場合は、使用者は各自の責任の元で適切な安全対策を講じてください。必要に応じて本機器を浄化してください。また、使用する材料に対するシーリング材の耐久性を確認してください。

機器を浄化すること

本機器を取り付けた後やシステムから取り外す前に、きれいな乾燥ガスで本機器を浄化し、使用した材料を完全に除去してください。

浄化する場合は適切な手順で行うこと

本機器の浄化は換気フードの下で行う必要があります。また、浄化作業を行う人は必ず手袋を着用してください。

爆発の危険性のある環境で機器を使用しないこと

爆発が起きるのを防ぐため、本機器を爆発の危険性のある環境で使用しないでください。ただし、そのような環境での使用が特別に保証されている場合は除きます。

適切な金具類を使用し、手順に従って金具の締めを行うこと

金具類は本機器の仕様と一致し、機器本来の用途に適したものである必要があります。金具類の取り付けや締めは、製造業者の指示に従ってください。

液体の漏れがないよう接続箇所を確認すること

本機器を設定する前に、すべての配管の接続を慎重に確認し、液体が漏れないようにしてください。マスフロー機器の安全に関する情報

安全なインレット圧力で使用すること

定格の最大圧力を超える圧力の下で本機器を絶対に使用しないでください (最大許容圧力については仕様書を参照)。

適切なバーストディスクを取り付けること

圧力のかかったガスを使用する場合は、万一システムが爆発した場合にシステムの圧力が上昇するのを防ぐため、真空システムに適切なバーストディスクを取り付けてください。

本機器に異物やゴミが混入しないようにすること

本機器の使用前または使用中に、ほこりやゴミ、繊維、ガラスの破片、金属片などの異物やゴミが混入しないようにしてください。本機器が損傷する可能性があります。

温度調整された機器を十分に温めてから使用すること

温度調整された機器が適切な作動温度にならないうちに使用すると、仕様通りの動作をしないことがあります。本機器が十分に温まるまでは目盛りをゼロに合わせたり、較正しないでください

2.6 질량 유량 장치 안전 정보

2.6.1 본 지침 매뉴얼에 사용되는 기호들

매뉴얼 전체에 사용되는 경고, 주의 및 참고 메시지의 정의.

참고

この表示は手順や使用方法、条件などに関する重要な情報が記載されていることを示しています。必ずお読みください。

注意

この表示を無視して誤った取り扱い(手順や使用方法など)をすると、製品が損傷する可能性が想定される内容を示しています。必ずお読みください。

경고

경고 표시는 위험을 나타냅니다. 이 표시는 올바르게 수행되거나 지켜지지 않을 경우, 사람에게 상해를 입힐 수 있는 절차, 수행지침, 상태 또는 이와 유사한 상황들에 대한 주의를 환기시킵니다.

위험

그만큼 위험 표시 피하지 않을 경우 사망이나 심각한 부상을 초래할 수 있는 임박한 위험한 상황을 나타냅니다.

2.6.2 장치에 표시된 기호들

다음 표는 장치에서 볼 수 있는 기호들을 설명합니다.

 컴 (전원) IEC 417, No. 5007	 곰 (전원) IEC 417, No. 5008	 접지(지면) IEC 417, No. 5017	 보호 접지(지면) IEC 417, No. 5019
 프레임 또는 새시 IEC 417, No. 5020	 등전위성 IEC 417, No. 5021	 직류 IEC 417, No. 5031	 교류 IEC 417, No. 5032
 직류와 교류 모두 IEC 417, No. 5019	 클래스 II 장비 IEC 417, No. 5172-a	 3상 교류 IEC 617-2, No. 020206	
 주의 (동봉 문서 참조) ISO 3864, No. B.3 1	 주의, 감전 위험 ISO 3864, No. B.3 6	 주의, 표면이 뜨거움 IEC 417, No. 5021	

2.6.3 안전 절차 및 예방조치

본 기계의 모든 작동 시에 다음의 일반 안전 예방조치를 준수하십시오. 아래 예방조치를 준수하지 않거나 본 매뉴얼의 다른 부분에 있는 특정 경고를 준수하지 않을 경우, 기계 사용 목적의 안전 기준을 위반하는 것이 되며, 장비가 제공하는 보호기능을 손상시킬 수 있습니다. MKS Instruments, Inc.는 고객이 본 요건을 준수하지 않는 경우에 대해서는 어떠한 책임도 지지 않습니다.

부품을 교체하거나 기계를 개조하지 마십시오

교체 부품을 설치하거나 기계에 허가되지 않은 어떠한 수정도 가하지 마십시오. 서비스와 수리가 필요한 경우에는 모든 안전 특성이 유지되도록 기계를 MKS 보정 서비스 센터(MKS Calibration and Service Center)로 보내주십시오.

자격이 있는 사람에게만 서비스를 받으십시오

작동하는 사람은 기계 겉면을 제거해서는 안됩니다. 부품 교체 및 내부 조정은 자격이 있는 서비스 기사에게만 받으실 수 있습니다.

전류가 통하는 회로에서 분리해 보관하십시오

전원 케이블을 연결한 채로 부품을 교체하지 마십시오. 일부 환경에서는 전원 케이블을 제거한 상태라도 위험 전압이 존재할 수 있습니다. 부상을 방지하려면, 전원을 항상 분리하고 회로를 만지기 전에 회로를 방전시키십시오.

위험한 물질과 함께 작동할 때는 주의를 기울이십시오

위험한 물질이 사용되는 경우, 사용자는 필요시 기계를 완전히 청소하여, 적절한 안전 예방조치를 준수할 책임을 지키고, 사용된 물질이 봉인 물질과 함께 사용해도 무방하다고 보증할 수 있어야 합니다.

기계를 청소하십시오

장치를 설치한 후나 시스템에서 장치를 제거하기 전에는 반드시 깨끗한 건조성 기체로 장치를 완전히 청소하여 이전에 사용된 유량 물질의 모든 흔적을 제거하십시오.

청소 시에는 적절한 절차를 사용하십시오

본 기계는 환기 후드 아래에서 청소되어야 하며, 인체 보호를 위해 장갑을 착용해야 합니다.

폭발성 환경에서 작동하지 마십시오

폭발을 방지하려면, 폭발성 환경에서 작동하도록 특별히 승인받지 않은 경우 본 제품을 폭발성 환경에서 작동하지 마십시오.

적절한 조립부품과 조임 절차를 사용하십시오

모든 기계 조립부품은 제품 사양과 일치해야 하고, 기계의 사용 목적에 부합해야 합니다. 제조업체의 지시에 따라 조립부품을 조립하고 조이십시오.

누출방지 조립부품을 점검하십시오

기계 설치를 진행하기 전에 기계의 모든 연관 연결부를 점검해 누출방지 설치가 되었는지 확인하십시오.

안전한 흡입 압력에서 작동하십시오

이 장치는 절대 정격 최대 압력보다 높은 압력에서 작동해서는 안 됩니다(최대 허용 압력에 대해서는 제품 사양을 참조하십시오).

적합한 안전 파열판을 설치하십시오

가압 가스 공급원에서 작동시, 시스템 폭발이 시스템 압력 상승을 일으키는 것을 방지하기 위해 적합한 안전 파열판이 진공 시스템에 설치되어야 합니다.

장치를 오염이 없는 곳에 보관하십시오

장치를 사용하기 전이나 사용 중에는 어떠한 종류의 오염 물질도 허용해서는 안 됩니다. 먼지, 때, 보풀, 유리 조각, 금속 조각과 같은 오염 물질은 영구적으로 장치를 손상시킬 수 있습니다.

온도 제어 장치의 경우 알맞은 시동 시간을 두십시오

온도 제어 장치는 장치가 설계 작동 온도와 일치하고 이 온도에서 안정화될 수 있도록 충분한 시간을 허용해야만 사양에 맞게 작동합니다. 시동이 완료될 때까지 장치를 영점 설정하거나 보정하지 마십시오.

3 General Information

3.1 Introduction

The MKS Type 649B is the RoHS-compliant version of the industry standard Type 649 instrument that provides both pressure control and flow metering in one compact unit. The 649 pressure controller includes a Baratron[®] capacitance manometer, proportioning control valve, closed-loop electronics, and patented thermal mass flow sensor. The closed-loop control circuitry enables the unit to function as a proportional-integral (PI) controller. The combination of a pressure controller and mass flow meter in one unit makes the 649 pressure controller the ideal solution for backside wafer cooling applications. In addition, the unit's compact size and small footprint reduce space requirements compared to multi-component systems.

The 649 pressure controller is available with full scale pressure ranges from 10 torr [1333 Pa] to 100 torr [13.3 kPa] and full scale flow rates from 10 to 5000 sccm (nitrogen equivalent). The 649 unit is metal sealed; the valve plug material can be metal, Viton[®], Kel-F[®], or Kalrez[®]. The unit can have either Cajon[®] 4-VCR[®] male (or equivalent) or 8-VCR[®] male (or equivalent) male fittings.

One Type "D" connector, located on the top of the unit, accepts the input power, and has both the pressure (input and output) and flow (output) signals. You can connect the 649B controller to an MKS Type 247 or 246 Mass Flow Controller Power Supply/Readout or a Type 647 Mass Flow and Pressure Programmer/Display unit.

The 649 pressure controller provides two user-settable alarm trip points. The pressure trip points can be set from 1 to 100% of full scale. Each trip point controls an open collector transistor. An LED light located on the top of the unit, indicates the trip point status.

CAUTION

The control valve within the 649 unit is not a positive shutoff valve. You may need to install a separate positive shutoff valve in your system.

3.1.1 Design Features of the Integral Mass Flow Meter

The design of the integral mass flow meter incorporates an advanced flow sensor (U.S. Patent¹; Foreign Patents Pending) and an optimized bypass. The latest generation two-element sensing circuit provides accurate, repeatable performance even in low flow ranges (< 10 sccm). Low temperature effect from ambient temperature change and a low attitude sensitivity effect are also ensured. The

¹ U.S. Patent 5461913; foreign patents pending.

newly optimized sensor/bypass arrangement minimizes the flow splitting error for gases with different densities, which dramatically improves measurement accuracy when gases other than the calibration gas are used.

3.1.2 Cleanliness Features

The design of the pressure controller ensures extremely low external leakage and minimizes a key source of particle generation, outgassing, and permeation. The design also incorporates minimal wetted surface area. To further ensure its cleanliness, the 649B controller undergoes precision machining as well as a proprietary cleaning process. The instrument is assembled and double-bagged in a Class 100 clean room.

3.2 How This Manual is Organized

This manual is designed to provide instructions on how to set up, install, and operate a Type 649 unit.

Before installing your Type 649 unit in a system and/or operating it, carefully read and familiarize yourself with all precautionary notes in the Safety Messages and Procedures section at the front of this manual. In addition, observe and obey all WARNING and CAUTION notes provided throughout the manual.

Chapter One, Warranty Information, explains the warranty policies for MKS Instruments and the 649B pressure controller.

Chapter Two, Safety, is the most important chapter, and explains the safety measures and procedures that must be followed when using this instrument.

Chapter Three, General Information, (this chapter) introduces the product and describes the organization of the manual.

Chapter Four, Installation, explains the environmental requirements and describes how to mount the instrument in your system.

Chapter Five, Overview, gives a brief description of the instrument and its functionality.

Chapter Six, Operation, describes how to use the instrument and explains all the functions and features.

Chapter Seven, Maintenance, lists any maintenance required to keep the instrument in good working condition.

Appendix A: Product Specifications, lists the specifications of the instrument.

Appendix B: Model Code Explanation, describes the model code.

Appendix C: Valve Orifice Selection, presents the information used to select the appropriate flow range for nitrogen and other gases.

3.2.1 Manual Conventions

The following conventions apply throughout this manual:

XXXXXX *For inputs:* Indicates that the line must be pulled low to activate the function.

For outputs: Indicates that the output is active low.

3.3 Customer Support

Standard maintenance and repair services are available through all our regional MKS Calibration and Service Centers, listed on the back cover. In addition, MKS accepts the instruments of other manufacturers for recalibration using the Primary and Transfer Standard calibration equipment located at all of our regional service centers. Should any difficulties arise in the use of your Type 649 instrument, or to obtain information about companion products MKS offers, contact any authorized MKS Calibration and Service Center. If it is necessary to return the instrument to MKS, please obtain an RMA Number (Return Material Authorization Number) from the MKS Calibration and Service Center before shipping. The RMA Number expedites handling and ensures proper servicing of your instrument.

Please refer to the inside of the back cover of this manual for a list of MKS Calibration and Service Centers.

WARNING All returns to MKS Instruments must be free of harmful, corrosive, radioactive, or toxic materials.

4 Installation

4.1 How To Unpack the Type 649 Unit

MKS has carefully packed the Type 649 unit so that it will reach you in perfect operating order. Upon receiving the unit, however, you should check for defects, cracks, broken connectors, etc., to be certain that damage has not occurred during shipment.

NOTE

Do not discard any packing materials until you have completed your inspection and are sure the unit arrived safely.

If you find any damage, notify your carrier and MKS immediately. If it is necessary to return the unit to MKS, obtain an RMA Number (Return Material Authorization Number) from the MKS Service Center before shipping. Please refer to the inside of the back cover of this manual for a list of MKS Calibration and Service Centers.

4.1.1 Opening the Package

The 649B controller is assembled, leak tested with helium, and calibrated in a clean room environment. The instrument is double bagged in this environment to ensure maintenance of its particle free condition during shipment. It is very important to remove the packaging according to clean room practices. To maintain at least a minimal level of clean room standards, follow the instructions below.

1. Remove the container in an ante room (garmenting room) or transfer box. Do not allow this container to enter the clean room.
2. Remove the inner bag in the clean room.

CAUTION

Only qualified individuals should perform the installation and any user adjustments. They must comply with all the necessary ESD and handling precautions while installing and adjusting the instrument. Proper handling is essential when working with all highly sensitive precision electronic instruments.

4.1.2 Unpacking Checklist

Standard Equipment:

- Type 649 Unit
- Type 649 Instruction Manual (this book)

Optional Equipment:

- Electrical Connector Accessories Kit - 649A-K1
- Interface cables (refer to Interface Cables, page 37)

4.2 Interface Cables

Use a CB649S-1-Mx or CB649-1-Mx cable (where x indicates code for the length) to connect the 649B controller to an MKS Type 247 or 246 Mass Flow Controller Power Supply/Readout or a Type 647 Mass Flow and Pressure Programmer/Display unit. The standard cable, CB649-1-M1 is 10 feet in length.

CABLE NO.	LENGTH	
	P1 TO P2	P1 TO P3
CB649-1-MA	2.0 FT	2.0 FT
CB649-1-M1	10.0 FT	10.0 FT
CB649-1-M2	100.0 FT	100.0 FT
CB649-1-M3	20.0 FT	20.0 FT
CB649-1-M4	30.0 FT	30.0 FT
CB649-1-M5	50.0 FT	50.0 FT
CB649-1-M6	40.0 FT	40.0 FT

MODEL CODE **CB649-1-M X**

BASIC MODEL NO. —————

MULTIPLE CONNECTORS & —————
& CABLE LENGTHS

SEQUENTIALLY ASSIGNED IDENTIFIER —————
FOR EACH CONFIGURATION

NOTE

To order a metal braided shielded cable, add an “S” after the cable type designation. For example, for an overall metal braided shielded cable order CB649S-1 for; order CB649-1 for a non-shielded cable.

4.2.1 Generic Shielded Cable Description

Should you choose to manufacture your own cables, follow the guidelines listed below:

1. The cable must have an overall metal *braided* shield, covering all wires. Neither aluminum foil nor spiral shielding will be as effective; using either may nullify regulatory compliance.
2. The connectors must have a metal case which has direct contact to the cable’s shield on the whole circumference of the cable. The inductance of a flying lead or wire from the shield to the connector will seriously degrade the shield’s effectiveness. The shield should be grounded to the connector before its internal wires exit.
3. With very few exceptions, the connector(s) must make good contact to the device’s case (ground). “Good contact” is about 0.01 ohms; and the ground should surround all wires. Contact to ground at just one point may not suffice.
4. For shielded cables with flying leads at one or both ends; it is important at each such end, to ground the shield *before* the wires exit. Make this ground with absolute minimum length. (A 6.35 mm piece of #22 wire may be undesirably long since it has approximately 5 nH of inductance, equivalent to 31 ohms at 1000 MHz). After picking up the braid’s ground, keep wires and braid flat against the case. With very few exceptions, grounded metal covers are not required over terminal

strips. If one is required, it will be stated in the Declaration of Conformity or in the instruction manual.

5. In selecting the appropriate type and wire size for cables, consider:
 - A. The voltage ratings;
 - B. The cumulative I^2R heating of all the conductors (keep them safely cool);
 - C. The IR drop of the conductors, so that adequate power or signal voltage gets to the device;
 - D. The capacitance and inductance of cables which are handling fast signals, (such as data lines or stepper motor drive cables); and
 - E. That some cables may need internal shielding from specific wires to others; please see the instruction manual for details regarding this matter.

4.3 Product Location and Requirements

- Ventilation requirements include sufficient air circulation
- Maintain the normal operating temperature between 0° and 50° C
- Maximum differential pressure is 150 psia [1034 kPa], consistent with the overpressure limit of the pressure transducer
Refer to *Applications with a Large Differential Pressure* page 56, for more information.
- Pressure transducer overpressure limit: 45 psia [310 kPa] or 2 times full scale, whichever is greater
- Provide power input at ± 15 VDC ($\pm 5\%$) @ 250 mA
 1. Maximum voltage/current at startup is ± 15 VDC ($\pm 5\%$) @ 250 mA
 2. Typical steady state voltage/current should be ± 15 VDC ($\pm 5\%$) @ 200 mA
- Warm up time: 5 minutes
- Use high purity gas and filters in line upstream of the controller
- Mount the 649B controller in an upright position, if possible, although any mounting orientation is satisfactory
Refer to *Installing the Unit*, page 43, for more information.
- Install a separate positive shutoff valve if your system cannot tolerate some leakage across the control valve in the 649B controller
The control valve is not a positive shutoff valve so some leakage across the valve may occur.

WARNING

Follow your corporate policy for handling toxic or hazardous gases. Your corporate policy on handling these gases supersedes the instructions in this manual. MKS assumes no liability for the safe handling of such materials.

- Install the 649B controller in a “flowing” system where gas is continually added and evacuated
Do **not** use the controller in a “dead-ended” system (a system which cannot remove excess pressure). The 649B controller is not designed to vent excess pressure to the atmosphere.
- Verify that your pressure system can withstand pressure equal to the full scale range of the pressure transducer
Your pressure system may be exposed to the full scale pressure since the 649B controller will control over the entire full scale range of the pressure transducer. As a precaution, you may choose to install a safety valve in your system to vent excess pressure.

4.4 Dimensions

NOTE

All dimensions are listed in inches with millimeters referenced in parentheses.

4.4.1 Front and Back Views

The front of the 649B controller has an arrow to indicate the direction of gas flow through the unit.

The back of the unit has the serial number tag and the pinout for the 15-pin Type “D” connector.

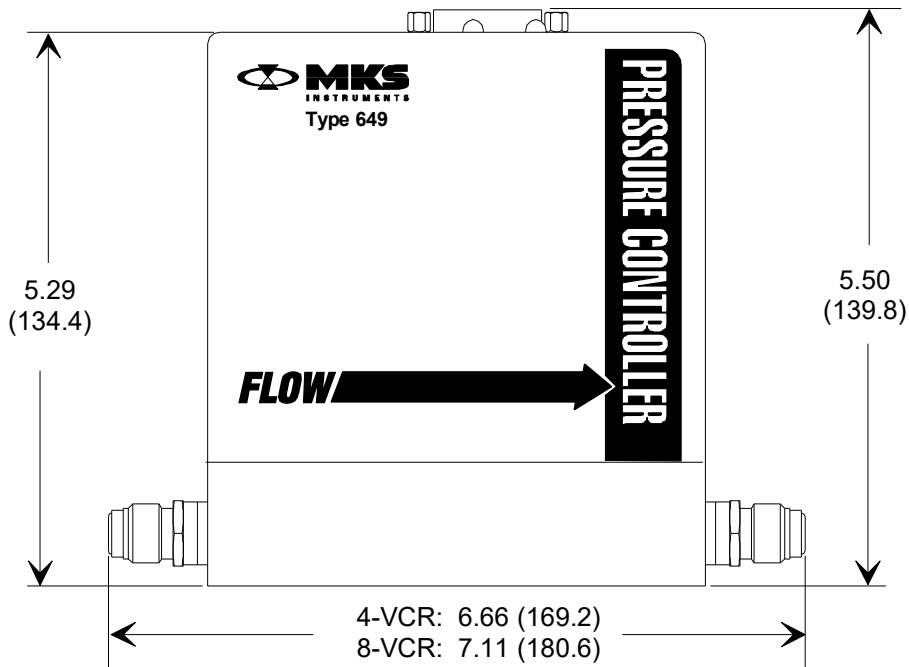

Figure 1 - Front View

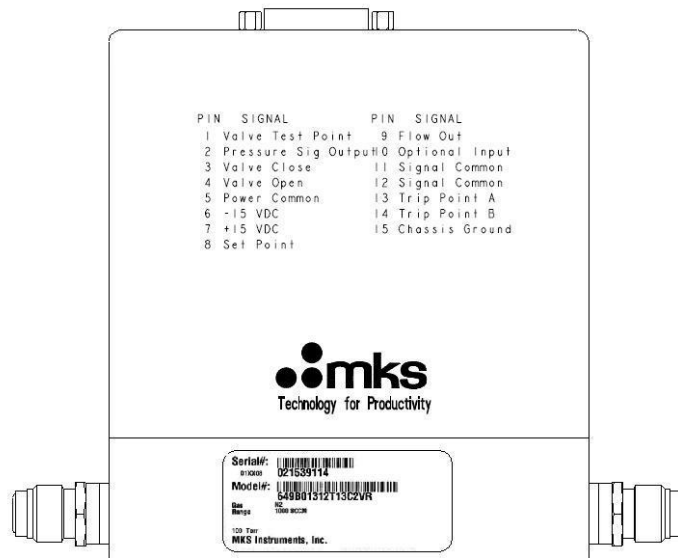

Figure 2 - Rear View

4.4.2 Side Views

The flow meter adjustments are located on the inlet side of the 649B controller.

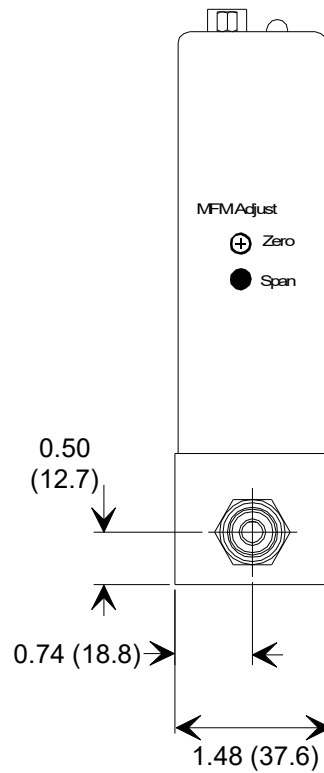

Figure 3 - Side View

4.4.3 Bottom View

The bottom of the 649B controller has mounting holes for mounting the unit, if desired.

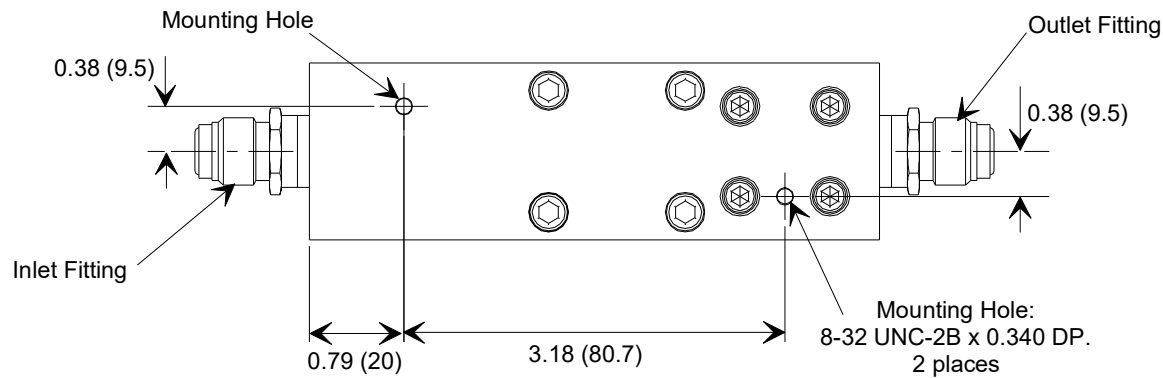

Figure 4 - Bottom View

4.5 Setup

This section covers how to install the 649B controller into your system.

4.5.1 Fittings

The 649 pressure controller is available with the following fittings:

- Cajon 4-VCR male compatible
- Cajon 8-VCR male compatible

4.5.2 Mounting Hardware

The 649B controller has two mounting holes located on the bottom or base of the unit. Use #8-32 UNC-2B hardware to mount the unit. Refer to Figure 4 shows the location and dimension of the mounting holes.

4.5.3 Gas Pressure

The control valve, housed inside the 649B controller enclosure, is rated for a maximum inlet pressure of 150 psia [1034 kPa]. Ensure that the inlet pressure is consistent with the overpressure limit of the pressure transducer. This will eliminate damage to the transducer should the valve open fully. Refer to Applications with a Large Differential Pressure, page 56, for more information.

The control valve is not a positive shutoff valve. Some leakage across the valve may occur. Refer to Appendix A: Product Specifications, page 67, for the leak integrity specifications. If necessary, install a separate positive shutoff valve in your system.

CAUTION

Take care not to expose the pressure transducer to pressures above its full scale range. Pressures exceeding 45 psia [310 kPa] or twice the full scale pressure (whichever is greater) may damage the pressure transducer.

4.5.4 Installing the Unit

The 649 Pressure Controller should be mounted to provide downstream pressure control. Connect the controller so that the flow arrow points toward the system whose pressure you need to control.

NOTE

Connect the 649B controller to your system so that the gas flows in the direction of the flow arrow on the front of the unit.

Downstream Pressure Control

Downstream pressure control occurs when the 649B controller is positioned *before* the controlled pressure volume in the gas flow path, so that the 649 unit controls the pressure downstream of the 649B controller itself. The gas enters the 649B controller on the flow meter side and flows in the direction of the flow arrow on the front of the unit. The outlet of the instrument is the controlled pressure port.

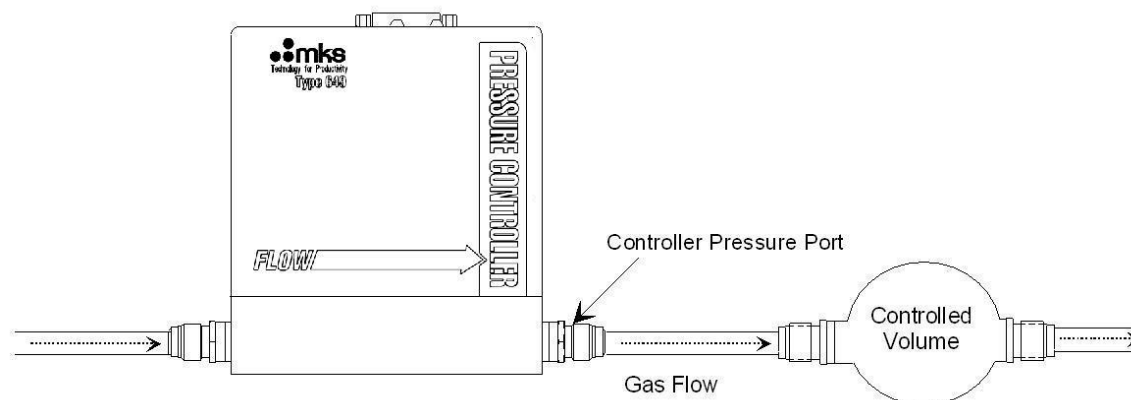

Figure 5 - Downstream Pressure Control

NOTE

The 649B controller is designed for downstream pressure control only. That is, it controls the pressure of a system located downstream of the 649B controller.

4.6 Electrical Information

4.6.1 I/O Connector

The 649B controller has one 15-pin, male Type "D" connector that provides the pressure output, setpoint input, and trip point output signals. Refer to Figure 6 for the location of the connector.

I/O Connector Pinout	
Pin Number	Assignment
1	Valve Test Point
2	Pressure Signal Out
3	$\overline{\text{Valve Close}}$
4	$\overline{\text{Valve Open}}$
5	Power Common
6	-15 VDC Supply
7	+15 VDC Supply
8	Setpoint Input
9	Flow Output
10	Optional Input
11	Signal Common
12	Signal Common
13	Trip Point A Out
14	Trip Point B Out
15	Chassis Ground

Table 1 - Connector Pin Assignments

Pressure Signal Output (Pin 2)

The 649B controller allows you to access the pressure signal from the pressure transducer, correct it in some way, and re-introduce it into pin 10 of the I/O connector to be used as the input signal in closed-loop control. This function is useful if you need to correct for a zero offset.

Pin 2 accesses the pressure signal as it travels from the pressure transducer to the control circuitry. Pin 10 re-introduces the signal into the 649B controller.

Setpoint Input (Pin 8)

The setpoint input signal can be a 0 to 10 Volt (factory setting) or 0 to 5 Volt signal. The range of the setpoint input signal must *match* the range of the pressure output signal. The 649B controller is initially configured for a 0 to 10 Volt pressure output signal. Therefore, the setpoint input signal must be 0 to 10 Volts, where 10 Volts represents 100% of full scale. To change the range of the pressure output signal to 0 to 5 Volts, you must reposition jumpers on the Transducer board. Refer to page 64 for instructions on changing the pressure output range.

NOTE

The 649B controller must have sufficient pressure on its inlet side to achieve the setpoint.

Flow Output Signal (Pin 9)

The flow output signal is available on pin 9. You can introduce this signal into another system to monitor the flow rate. The flow output signal is 0 to 5 Volts, which is standard for most thermal mass flow meters.

Optional Input (Pin 10)

Use pin 10 to introduce another signal, such as a zero corrected pressure signal, into the control circuitry of the 649B controller. When a signal equal to or greater than 0.25V is introduced on pin 10, it overrides the Pressure Output signal (pin 2) until the signal on pin 10 drops below -0.8V.

NOTE

To assure the Optional Input is disabled, pin 10 should be left floating or the voltage on pin 10 should be held below -1V (but not below -14V).

The Trip Point Outputs (Pins 13 and 14)

The 649B controller offers two alarm trip points: Trip Point A and Trip Point B. Each trip point has an LED and adjustment pot on the top cover. The trip points are open collector transistors.

The trip points can be set from 1 to 100% of full scale by adjusting the appropriate trip point pot located on the top of the unit. The trip point setting is a 0 to 5 VDC signal available inside of the unit.

Use the appropriate trip point output signal to control a relay or another piece of equipment, such as a valve, or as a digital input to a computer. The trip point signal is pulled to ground when the trip point is on. The voltage value of the pin is 5 Volts when the respective trip point is off.

Refer to *Trip Points*, page 55, for a complete description of the trip points.

4.7 Initial Configuration

The 649 pressure controller is shipped from the factory with the configuration listed in Table 2.

Initial Configuration		
Feature	Setting	Options
Pressure Control	Downstream	no option
Setpoint Input*	0 to 10 V	0 to 5 V
Pressure Output	0 to 10 V	0 to 5 V
Flow Output	0 to 5 V	no option
Trip Point A Setting Action	100% F.S. Trip high (TH)	1 to 100% F.S. Trip low (TL)
Trip Point B Setting Action	1% F.S. Trip low (TL)	1 to 100% F.S. Trip high (TH)
P Term	Position 0	8 settings (0 through 7) on a 10 position dial (8 repeats setting 0; and 9 repeats setting 1)
I Term	Position 0	10 settings, 0 through 9
<i>* Input must match the pressure output signal range</i>		

Table 2 - Initial Configuration

5 Installation

5.1 General Information

Figure 6 shows the top view of the 649 pressure controller. The user adjustable controls for pressure zero, pressure span, the P term, the I term, and the trip points are located on the top of the controller. The trip point settings can be measured through two test jacks, located under the enclosure, on the Transducer board. Refer to Figure 14 for the location of the test jacks.

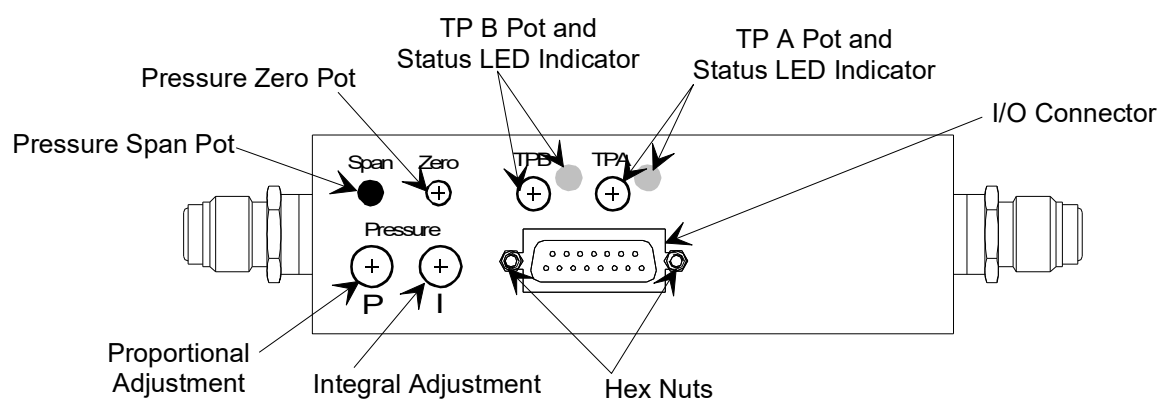

Figure 6 - Top View

5.1.1 Pressure Control Range

The 649B controller can control *pressure* over a range of 5 to 100% of full scale. This means that a 649B controller with a 100 Torr [13.3 kPa] pressure transducer can control pressure from 50 torr [6.66 kPa] to 1000 torr [133 kPa], whereas a unit with a 100 torr [13.3 kPa] pressure transducer can control pressure from 5 torr [666 Pa] to 100 torr [13.3 kPa].

5.1.2 Flow Range

The flow adjustments are located on the inlet side of the controller. The adjustments include the flow zero and flow span pots.

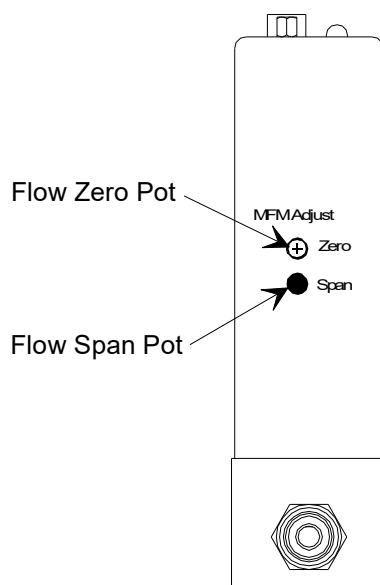

Figure 7 - Location of Flow Meter Adjustments

5.1.3 A Typical Control System

The 649 Pressure Controllers are used in a wide variety of control systems, most of which share several characteristics. Typically, a control system consists of four basic parts:

- Pressure transducer
- Control electronics
- Control valve
- Pressure system (whose pressure is being controlled)

The 649 Pressure Controller provides the first three components. The pressure transducer is an MKS Baratron capacitance manometer. The 649 unit contains the electronics necessary for pressure control. The control valve included in the 649B controller is a proportional control valve. The pressure system can be any process whose pressure you need to control. In addition, the 649B controller is capable of metering the mass flow of the gas during the pressure control operation.

5.2 How The 649 Pressure Controller Works

The 649B controller compares the pressure reading to the setpoint, and positions the valve to maintain, or achieve, the setpoint pressure. The controller functions as a PI (Proportional-Integral) controller. Both the Proportional (P) term, and the Integral (I) term have adjustable dials on the top of the 649B controller.

Downstream pressure control is defined as having the process chamber located downstream of the 649B controller. Therefore, the 649B controller controls the pressure of the process chamber located downstream.

Example

Assume that your 649B controller is positioned for downstream control. The 649B controller is positioned *before* the controlled pressure volume so it will regulate the pressure of the gas entering the pressure system. Figure 5, page 43, shows the correct location for the 649B controller.

When the actual pressure reading is *less than* the setpoint value, the 649B controller opens the valve to increase the amount of gas entering the system. As the valve opens, gas enters the pressure system, so the pressure rises to meet the setpoint value.

When the actual pressure reading is *greater than* the setpoint value, the 649B controller closes the valve to decrease the amount of gas entering the system. As the valve closes, less gas enters the pressure system, so the pressure drops to meet the setpoint value.

5.3 Flow Measurement Overview

The 649B controller measures the mass flow rate of a gas.

5.3.1 Flow Path

Upon entering the 649B controller, the gas stream passes first through the metering section of the instrument for its mass flow to be measured. The gas moves on through the control valve, which regulates the pressure according to the given setpoint, and then exits the instrument at the established pressure.

The metering section consists of one of the following:

- A sensor tube for ranges ≤ 10 sccm (N_2 equivalent)
- A sensor tube and parallel bypass for ranges > 10 sccm (N_2 equivalent)

The geometry of the sensor tube, in conjunction with the specified full scale flow rate, ensures fully developed laminar flow in the sensing region. The bypass elements, in those instruments containing them, are specifically matched to the characteristics of the sensor tube to achieve a laminar flow splitting ratio which remains constant throughout each range.

5.3.2 Measurement Technique

The flow measurement is based on differential heat transfer between temperature sensing heater elements which are attached symmetrically to the sensor tube. This senses the thermal mass movement which is converted to mass flow via the specific heat, C_p , of the gas. The resulting signal is amplified to provide a 0 to 5 VDC output which is proportional to mass flow.

5.4 Tuning the 649 Pressure Controller

Tuning optimizes the way the 649 unit controls your system. The Proportional (P) and Integral (I) terms adjust the response of the 649B controller. The controller responds to changes in either the pressure of the system or the value of the setpoint.

5.4.1 Proportional Term

The Proportional (P), or gain, term is used as a constant to create a valve drive signal that is proportional to the error signal. The error signal is multiplied by the proportional control setting, thus creating a proportional valve drive signal. The higher the proportional control, the greater the change in valve drive signal. Typically, a higher proportional control setting yields a faster response. However, too high a proportional control setting will cause the pressure to oscillate around the setpoint. Too low a proportional control setting will result in a slow response from the controller. Figure 8 shows the effects of the Proportional term.

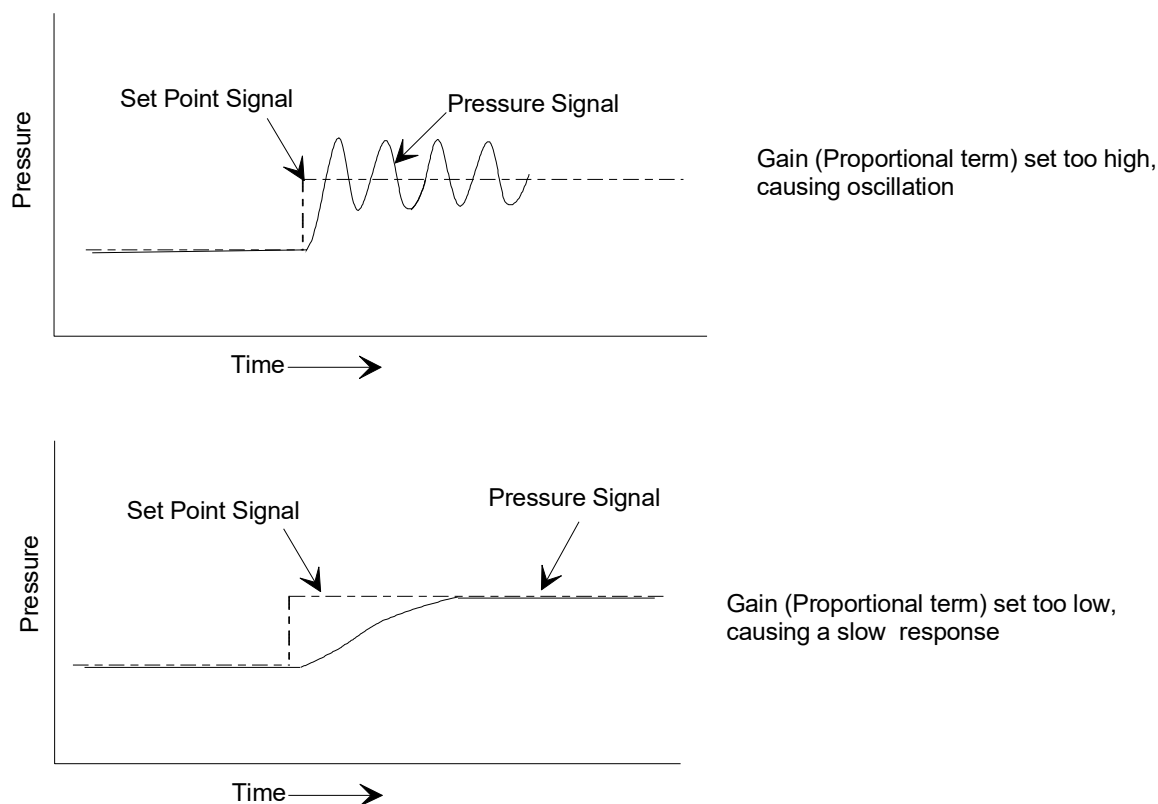

Figure 8 - Effects of the Proportional Control Term

Adjusting the Proportional Control

The Proportional (P) term adjustment is located on the top of the 649 unit, as shown in Figure 6, page 47. The control is a 10-position dial, though it uses only 8 values. The last positions, 8 and 9, repeat

the values of positions 0 and 1. The initial setting is 0. As you increase the setting number, the value of the term increases by a factor of approximately 2.8.

5.4.2 Integral Term

The action of the Integral (I) term creates a valve drive signal that is proportional to the magnitude and sign of the area under the error signal curve (error signal with respect to time). Therefore, as time passes, the integral term acts to position the valve to reduce the error signal to zero. An increase in the integration time increases the period over which the error signal is generated, and the system response gets slower. Figure 9 shows the effects of the Integral term.

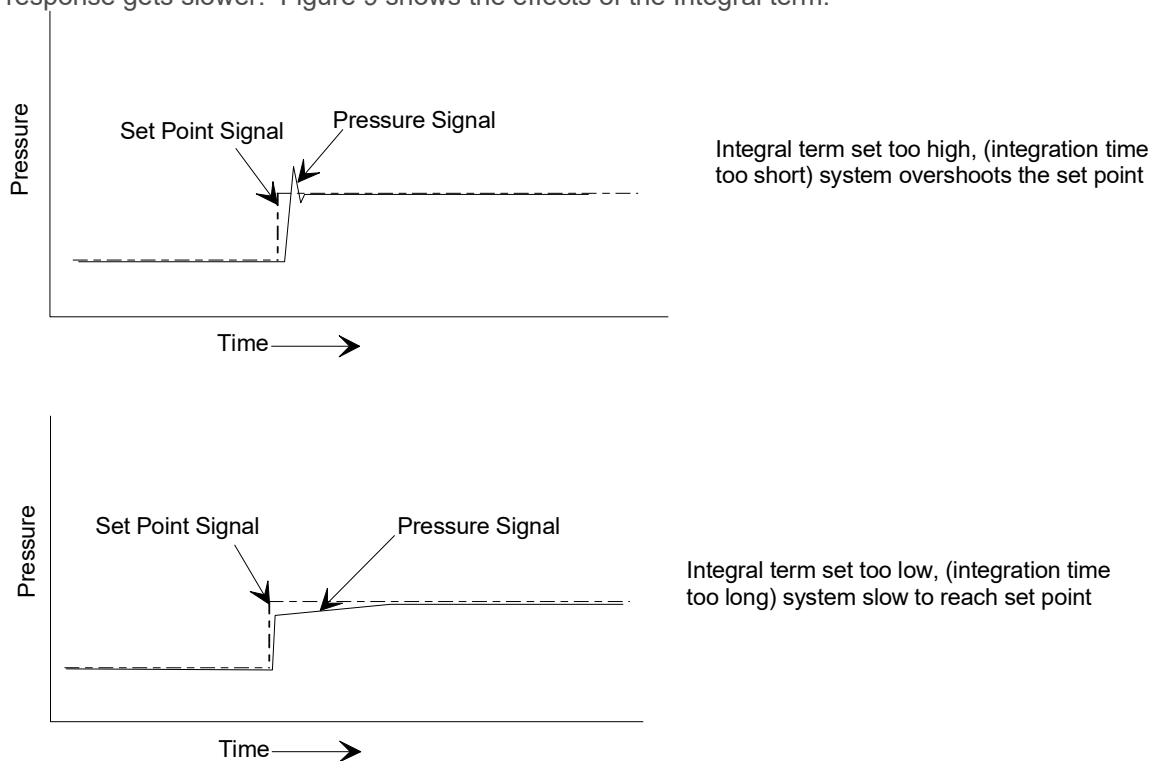

Figure 9 - Effects of the Integral Control Term

Adjusting the Integral Control

The Integral (I) term adjustment is located on the top of the 649 unit, as shown in Figure 6, page 47. The control is a 10-position dial where the 0 setting has the *longest* integration time; the 9 position setting has the *shortest* integration time. The initial setting is 0.

5.4.3 Tuning the 649B controller

Tuning the 649B controller involves adjusting the Proportional and Integral terms to optimize the response of the controller *in your system*. Since every system is different, the optimum settings for the P term and I term will vary. Also, the response of the system to increasing and decreasing pressures may vary. Tune the system to provide the best response in the direction of pressure change that you anticipate.

The following graphs show the response of the 649B controller to changes in the setpoint. The setpoint changed from 4 torr [533 Pa] (2 Volts) to 6 torr [800 Pa] (3 Volts), and back again.

NOTE

The following three graphs were generated on a system consisting of a 649 controller with a 10 torr [1333Pa] pressure transducer, 1000 sccm flow of nitrogen gas, 1552 torr [207 kPa] inlet pressure, and 1 liter system volume. Tuning with nitrogen may not offer maximum performance if another gas is used for processing.

The same P and I term values may not create the same effect in your system.

Controller Response with the Initial Values

The initial values ($P = 0$; $I = 0$) yield:

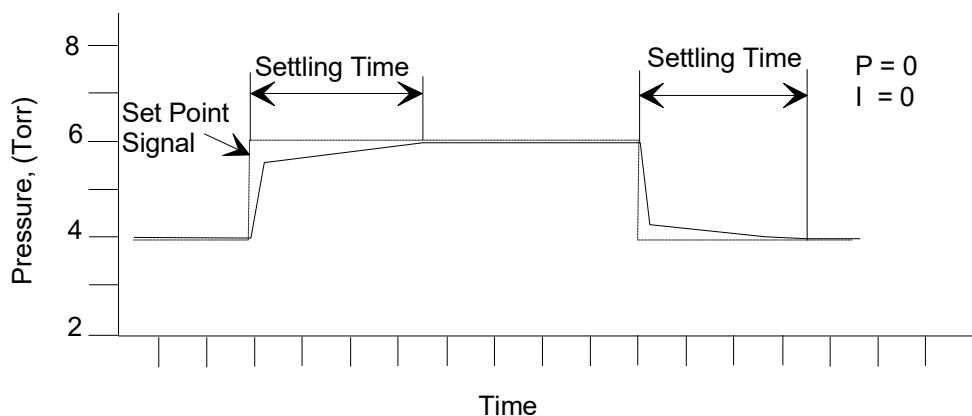

Figure 10 - Controller Response with Initial P Term and I Term Values

The controller response is slow to reach the setpoint, however, there is no pressure overshoot and no oscillation. Increase the P term to create a faster response.

Controller Response with Increased P Term

Increasing the P term to 1 while holding the I term at 0 yields:

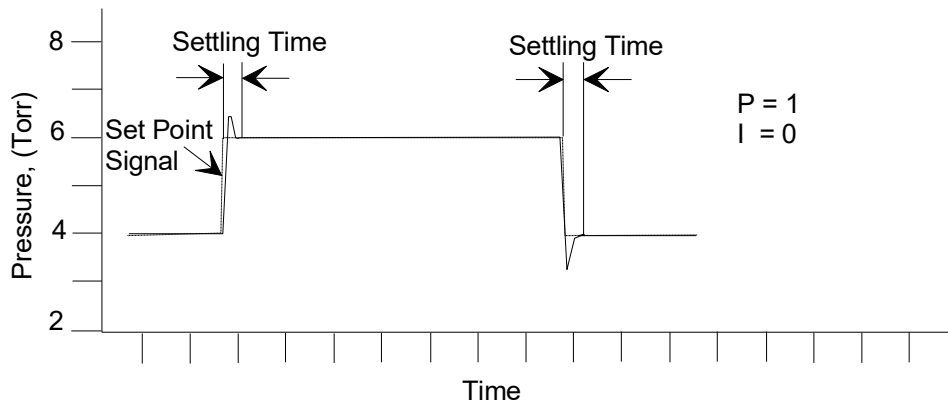

Figure 11 - Controller Response with Increased P Term

The controller responds much faster; however, some overshoot occurs.

Controller Response with Increased I Term

Reducing the P term to 0 and increasing the I term to 5 yields:

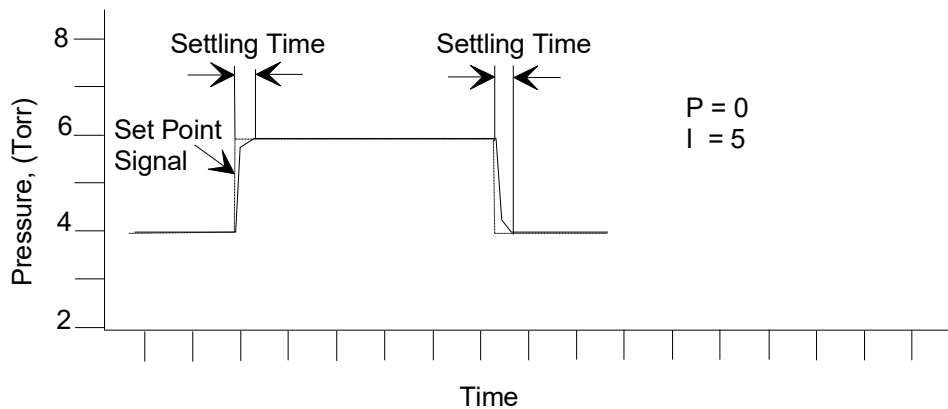

Figure 12 - Controller Response with Increased I Term

The response of the controller is quick, yet no overshoot occurs. This combination of P term and I term yields the best control for our example system.

5.5 Priority of Commands

The 649B controller has an established hierarchy that it uses to determine which commands take precedence. The commands and operating modes are listed according to the order of priority (from highest to lowest):

- Valve Close Command
 - Valve Open Command
 - Setpoint Recognition Operating Mode
 - Closed-Loop Control Operating Mode

Valve Close and Valve Open Commands: The valve override commands immediately move the valve to the appropriate position, either closed or open. These valve commands take precedence over any other operation. The overline ($\overline{\quad}$) indicates that the valve commands are active when their respective pins are pulled low. For example, if the valve is currently operating under pressure control to maintain a desired pressure, and the Valve Open pin (pin 4) is pulled low, the valve will move to the fully open position. The Valve Close command has the highest priority. Therefore, if both the Valve Open and Valve Close commands are issued, the valve will move to the fully closed position.

Setpoint Recognition Operating Mode: The 649B controller can control pressure, within its specifications, over the range from 5 to 100% of full scale. Under certain conditions the 649B can control below 5% down to 1%, although performance in this control range is application dependent. If the setpoint signal is *less than* 1% of full scale, the setpoint recognition becomes effective. The 649B controller positions its valve in the fully closed position. Increase the setpoint signal to a value *greater than* 1% of full scale to resume pressure control.

Closed-Loop Control Operating Mode: When the 649B controller operates in closed-loop control mode, it compares the pressure signal from its transducer (pin 2) or any signal on the Optional Input pin (pin 10) to the setpoint. The 649B controller positions its valve to achieve or maintain the setpoint pressure (or other variable if the Optional Input is used) in the system. Closed-loop control mode has the lowest priority. The 649B controller defaults to closed-loop control in the absence of any higher priority commands.

Refer to *Table 1*, page 44, for more information on the Optional Input function.

5.6 Trip Points

The 649B controller provides two trip points (Trip Point A and Trip Point B). Each trip point operates independently and controls an open collector output that can be connected to an external relay. Each trip point has an adjustment pot, a status LED, and a test jack. Refer to Figure 6. for the location of the trip point adjustment pots and LEDs. The test jacks are located inside of the unit, under the enclosure, as shown in Figure 14. Refer to *How to Adjust the Trip Point Values*, page 59, for instructions on changing the trip point values.

5.6.1 Action of the Trip Points

The trip points can be turned on when the pressure is above or below the trip point value, depending upon the location of jumpers on the Transducer board. The initial configuration is:

- Trip Point A is set to trip high; it is on when the pressure is *above* the trip point (it is off when the pressure is below the trip point value)
- Trip Point B is set to trip low; it is on when the pressure is *below* the trip point (it is off when the pressure is above the trip point value)

When on, the trip point is connected through the collector of an NPN transistor, to power ground. Refer to Trip Point Specifications, page 69, for the ratings. You can use the unit's trip point output (available on pins 13 and 14 of the I/O connector) for further process control. The complete pinouts for the I/O connector are in Table 1.

To change the action of a trip point, refer to How to Select the Trip Point Action, page 61.

NOTE

The trip points react to the pressure signal only, not the flow signal.

5.7 Applications with a Large Differential Pressure

Applications with a large differential pressure between the inlet and outlet, or a large inlet pressure, may require special precautions:

- *If the inlet pressure is more than two times the pressure transducer full scale pressure or 45 psia [310 kPa], whichever is greater*

You must ensure that the valve will never be fully opened to the pressure transducer. Pressures more than 45 psia [310 kPa] or two times the pressure transducer full scale (whichever is greater) may damage the pressure transducer.

- *The inlet pressure on the valve is 150 psia [1034 kPa]*

This is the maximum inlet pressure rating of the valve. The force of high inlet pressure on the valve may inhibit valve movement. A normally closed valve may be unable to open.

5.8 Labels

The 649B controller carries a serial number label which identifies the serial number, model number, calibration gas, full scale flow rate, and pressure range. It also displays the CE Mark which indicates compliance with European directives. The serial number label is located on the back of the unit.



Figure 13 - Serial Number Label

6 Operation

6.1 How to Check the Pressure Transducer Zero

Check the pressure transducer zero before operating the unit initially and then periodically as required. The zero can be set (or reset) by adjusting the zero potentiometer located on the top cover of the 649B controller or, on the front panel of an MKS Power Supply/Readout if you are using one.

NOTE The outlet port serves as the pressure transducer inlet port. Figure 1 shows the flow direction arrow.

To zero the pressure transducer within the 649B controller, you must pump the unit, with the power on, down to a pressure less than the pressure transducer's resolution (0.01% of Full Scale).

NOTE The zero adjustment must be made at a pressure less than the pressure transducer's resolution (0.01% of F.S.).

In addition, you should position the unit *in the same orientation as it will be installed in your system.*

Zeroing a pressure transducer above its stated minimum resolution creates a *zero offset* relative to true absolute pressure. All subsequent readings are then linear and accurate *relative to the offset value.*

NOTE If your system cannot achieve a sufficiently low pressure to set the pressure transducer zero, you may use a vacuum leak detector with sufficient vacuum pumping (to achieve a proper zeroing pressure). In this case, mount the unit *in the same plane of orientation as it will be during actual use.*

1. Install the 649B controller in a system and connect a power supply/readout.

The pressure signal is available on pin 2 of the I/O connector. Use either pin 11 or 12 as the ground. Refer to Table 1 for the pinout of the connector.

2. Pump the system down to a pressure below the resolution of the pressure transducer. Table 3 lists the recommended pressure levels.

Highest Pressure for Zero Adjustment of the Pressure Transducer	
Full Scale Range	Pressure
10 torr [1.33×10^3 Pa]	$< 5 \times 10^{-4}$ torr [6.66×10^{-2} Pa]
100 torr [1.33×10^4 Pa]	$< 5 \times 10^{-3}$ torr [6.66×10^{-1} Pa]
1000 torr [1.33×10^5 Pa]	$< 5 \times 10^{-2}$ torr [6.66 Pa]

Table 3 - Highest Pressure for Zero Adjustment of the Pressure Transducer

- Using a small screwdriver, adjust the ZERO pot until the readout displays zero (0000). Refer to Figure 6 for the location of the ZERO pot.

6.2 How to Adjust the Pressure Transducer Span

Only adjust the SPAN pot in conjunction with a calibration transfer standard. **Do not** adjust the span setting if a calibration transfer standard is not available. Instead, contact an MKS Service Center for calibration.

6.3 How to Zero the Integral Mass Flow Meter

Ensure that no gas flow is entering the 649B controller.

- Apply gas, at a regulated pressure, to the 649B controller.
- Close the positive shutoff valve downstream of the instrument.
- Command the control valve open by connecting the valve open pin to signal ground.

On the Type “D” connector, connect pin 4 (valve open) to pin 11 or 12 (signal ground). A positive flow may occur momentarily while the gas pressure equalizes across the 649B controller.

Adjust the Zero

- Once flow through the controller has stopped (reached zero flow), remove the valve open command.
- Turn the ZERO pot (located on the side of the controller) until the readout displays zero. Refer to Figure 7 for the location of the ZERO pot.
- Open the positive shutoff valve.

The controller may indicate a small, positive flow (<2.0% F.S.) due to a leak through its control valve. However, do **not** “zero out” this flow since it represents an actual flow measurement inherent in the system.

6.4 How To Tune the 649B controller

You may need to tune the 649B controller to optimize how it controls your system. Tuning consists of varying the P (Proportional) and I (Integral) parameters to achieve the fastest, smoothest response to changes in the setpoint value. Ideally, the 649B controller should respond to a new setpoint value by rapidly changing the pressure in the system to match the setpoint with little under or overshoot. Refer to Section 5.2, page 48, and Section 5.4 page 50, for a complete description of the effects of the P and I terms.

The P term and the I term are initially set to position 0. The controls are located on the top of the unit, as shown in Figure 6. Each control has a 10-position dial. The P term has only eight values; positions 8 and 9 repeat the values of positions 0 and 1.

1. Send your setpoint signal.

If you are using multiple setpoints, send the most critical setpoint.

2. Change the setpoint in the direction that you expect the system to deviate in and observe the controller response.

A properly tuned controller will reach the new setpoint rapidly, without overshoot.

- If the controller is too slow to reach the setpoint, increase the P term.
- If the pressure fluctuates around the setpoint, decrease the P term.
- If the pressure overshoots the setpoint and then settles to the correct pressure, increase the I term.

3. Repeat steps 1 and 2 until the response of the controller is optimized.

4. Change the setpoint in the opposite direction and observe the response.

Although the response may vary slightly, it should be acceptable. If it is not acceptable, follow the guidelines in steps 1 and 2 to tune the controller.

6.5 How To Adjust the Trip Point Values

Equipment required: digital voltmeter (DVM), 4.8 mm hex or open-ended wrench

CAUTION

Only qualified individuals should perform the adjustments. You must comply with all the necessary ESD and handling precautions while adjusting the instrument. Proper handling is essential when working with all highly sensitive precision electronic instruments.

Each trip point has a test jack that allows you to measure the trip point setting. The test jacks are located inside the unit. Figure 14 shows the location of the test jacks and a ground connection. The trip point adjustment pots, located on the top of the unit, allow you to vary the trip point setting.

The range of the trip point setting is 0 to 5 Volts, corresponding to 0 to 100% of pressure transducer full scale.

NOTE

The trip point range is from 0 to 5 Volts, regardless of the range of the setpoint input and pressure output signals.

1. Stop the gas flow through the 649B controller.
2. Remove any leads or wires attached to the connector on the 649B controller.
3. Use a 4.8 mm hex wrench (or open-ended wrench) to remove the hex nuts on each side of the I/O connector.

Refer to Figure 5 for the location of the hex nuts on the I/O connector. Use a Philips screwdriver to remove pairs of screws from both ends of the enclosure.

Place the hex nuts and screws aside for safe keeping.

4. Position the controller with the front side facing you and pull up on the enclosure to remove it. The board assembly will be visible, with the Transducer board facing you and the Control board behind it.
5. Insert the positive test probe into the test jack labeled "TP A" and the ground probe into the test jack labeled "Gnd."
Insert the probes sufficiently to obtain a good reading. There is no back plane in the test jacks to stop the probe.
6. Use a small screwdriver to adjust the trip point adjustment pot labeled "TP A".
Refer to Figure 6 for the location of the trip point adjustment pots. Turning the pot clockwise raises the trip point setting.
7. Repeat steps 1 and 2 to adjust TP B.
8. Slide the enclosure over the unit and press it in place.
9. Attach the hex nuts to the I/O connector and Philip screws removed in step 3.
10. Reconnect the leads and wires.

Refer to *How to Select the Trip Point Action*, page 61, to change the action of the trip points.

6.6 How to Select the Trip Point Action

Equipment required: 4.8 mm hex or open-ended wrench

The 649B controller is initially configured with TP A set to trip high (it is on when the pressure is *above* the trip point pressure) and TP B set to trip low (it is on when the pressure is *below* the trip point pressure). To change the action of the trip points you must remove the cover of the unit and change jumpers on the Transducer board. Each trip point has a jumper block with the jumper positions labeled TL (trip low) and TH (trip high).

1. Stop the gas flow through the 649B controller.
2. Remove any leads or wires attached to the connector on the 649B controller.

Use a 4.8 mm hex wrench (or open-ended wrench) to remove the hex nuts on each side of the I/O connector.

Refer to Figure 6 for the location of the hex nuts on the I/O connector. Use a Philips screwdriver to remove pairs of screws from both ends of the enclosure.

Place the hex nuts and screws aside for safe keeping.

3. Position the controller with the front side facing you and pull up on the enclosure to remove it. The board assembly will be visible, with the Transducer board facing you and the Control board behind it.
4. Locate the jumper blocks labeled “JP4” and “JP3” in the middle of the Transducer board. Refer to Figure 14 for the location of the jumper blocks.

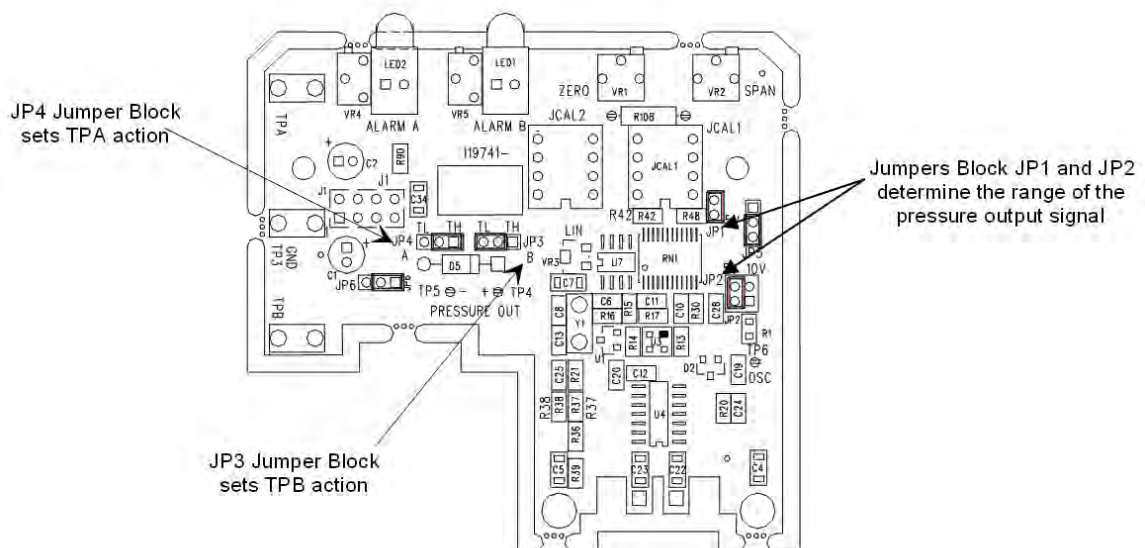

Figure 14 - Jumper Positions on the Transducer Board

5. Position the jumper on jumper block “JP4” to select the action for TP A. Jumper block “JP3” controls TP B.

The board silk-screen defines the jumper positions. TH indicates that the trip point will be on when the pressure is above the trip point, and TL indicates that the trip point will be on when the pressure is below the trip point.

6. Slide the enclosure over the unit and press it in place.
7. Attach the hex nuts to the I/O connector and Philip screws removed in step 2.
8. Reconnect the leads and wires.

6.7 How To Use Trip Points as Error Indicators

You can use the trip points to indicate when the error signal deviates from a given range. The error is defined as the difference between the actual pressure reading and the setpoint.

For example, assume you have a 100 torr [13.33 kPa] unit and your setpoint is 50 torr [6.666 kPa]. You want the trip points to illuminate when the error is more than $\pm 5\%$ of the setpoint value, which indicates that the pressure reading has deviated by more than ± 2.5 torr [0.333 kPa]. This allows the pressure to vary from 47.5 to 52.5 torr [6.333 to 6.999 kPa].

The 649B controller is initially configured with TP A on *above* the trip point and TP B on *below* the trip point. If you have not changed the action of either trip point, you may follow the steps below. If you have changed the action of the trip points, you need to reset them back to the initial configuration for this example. Refer to *How to Adjust the Trip Point Values*, page 59, for instructions.

1. Calculate the trip point voltage that corresponds to each trip point value:

$$\frac{\text{Trip point pressure (torr)}}{\text{Full scale pressure (torr)}} * \text{TP adjustment range (V)} = \text{Trip point voltage (V)}$$

where the full scale pressure is 13.33 kPa and the TP adjustment range is 5 Volts.

$$TP A: \frac{6.999 \text{ kPa}}{13.33 \text{ kPa}} \times 5 \text{ V} = 2.625 \text{ Volts}$$

$$TP B: \frac{6.333 \text{ kPa}}{13.33 \text{ kPa}} \times 5 \text{ V} = 2.375 \text{ Volts}$$

2. Measure the value of TP A by inserting a positive test probe into the test jack labeled “TP A” and the ground probe into the test jack labeled “Gnd.”

The ground connection and the test jacks are located inside the unit on the Transducer board, as shown Figure 14. A 0 to 5 V signal corresponds to a 0 to 100% full scale pressure.

3. Use a small screwdriver to adjust the pot for TP A, located on the top of the unit, to set TP A to 2.625 Volts.

Refer to Figure 6, for the location of the trip point adjustments.

4. Measure the value of TP B by inserting a positive test probe into the test jack labeled "TP B" and the ground probe into the test jack labeled "Gnd."
5. Use a small screwdriver to adjust the pot for TP B, to set TP B to 2.375 Volts.

The trip points will be off when the pressure reading is between 47.5 to 52.5 torr [6.333 to 6.999 kPa]. Should the pressure deviate from this range the appropriate trip point will turn on and its LED will illuminate. Trip Point A will turn on when the pressure exceeds 52.5 torr [6.999 kPa] and Trip Point B will turn on when the pressure falls below 47.5 torr [6.333 kPa].

6.8 How To Change the Pressure Output Signal Range

The pressure output signal can be a 0 to 10 Volt (initial setting) or 0 to 5 Volt signal. To change the range of the pressure output signal, and therefore, the setpoint input, you must remove the cover of the 649 pressure controller and reposition two jumpers on the Transducer board.

NOTE

The range of the pressure output signal determines the range used for the setpoint input signal. The initial configuration is for a 0 to 10 Volt pressure output signal. Therefore, a setpoint input signal of 10 Volts is equal to 100% of full scale. If you change the range of the pressure output signal to 0 to 5 Volts, a 2.5 Volt setpoint signal would be 50% of full scale.

1. Stop the gas flow through the 649 pressure controller.
2. Remove the power supply and any other leads or wires attached to the connector on the 649B controller.
3. Use a 4.8 mm hex wrench (or open-ended wrench) to remove the hex nuts on each side of the I/O connector.
4. Refer to Figure 4 for the location of the hex nuts on the I/O connector. Use a Philips screwdriver to remove pairs of screws from both ends of the enclosure.
5. Place the hex nuts and screws aside for safe keeping.
6. Position the controller with the front side facing you and pull up on the enclosure to remove it.

The MKS logo is displayed on the front of the unit. The board assembly will be visible, with the Transducer board facing you. The Control board is connected to the back of the Transducer board.

7. Locate the jumper block labeled "JP2" on the right-hand side of the Transducer board.

Refer to Figure 14 for the location of the "JP2" jumper block.

8. Position the jumper vertically, according to the silk-screen on the board.

Position the jumper on the right-hand side for 0 to 10 Volt operation; position the left-hand side for 0 to 5 Volt operation.

9. Locate the jumper block labeled JP1, above jumper block JP2.
10. Remove the jumper on JP1 for 10 Volt operation.
Position the jumper on the pins for 5 Volt operation.

11. Slide the enclosure cover over the unit.
12. Attach the hex nuts to the I/O connector and Philip screws removed in step 3.
13. Reconnect the leads and wires.

7 Maintenance

7.1 General Information

Periodically check for wear on the cables and inspect the enclosure for visible signs of damage.

7.2 Zero Adjustment

For best accuracy and repeatability, you should check the zero setting for both the pressure transducer and the flow meter periodically and reset it, if necessary. Refer to *How to Check the Pressure Transducer Zero*, page 57, and *How to Zero the Integral Mass Flow Meter*, page 58, for instructions on setting the zero. The frequency of checking the zero is dependent on the specific accuracy and repeatability required by your process. It is also recommended that the instrument be recalibrated annually if no other time interval has been specifically established. Refer to the inside of the back cover of this instruction manual for a complete list of MKS Calibration and Service centers.

Appendix A

Performance Specifications

Accuracy							
Pressure Transducer	$\pm 0.5\%$ Reading ²						
Pressure Controller	$\leq \pm 0.1\%$ F.S. ³						
Mass Flow Meter	$\pm 1.0\%$ F.S. ² typical						
CE Compliance							
Electromagnetic Compatibility ⁴	EMC Directive 89/336/EEC						
Control Adjustments							
Integral	10 positions (0 through 9)						
Proportional	8 positions (0 through 7; positions 8 and 9 repeat settings 0 and 1)						
Control Repeatability	$\pm 0.2\%$ F.S.						
Leak Integrity							
Internal to external	$< 10^{-9}$ scc/sec He						
Through closed <i>metal</i> or Kel-F valve	$< 2\%$ F.S. (N ₂ at 25 psia [172 kPa] to atm. differential)						
Through closed <i>elastomer</i> valve	$< 1 \times 10^{-3}$ scc/sec He						
Maximum Operating Differential Pressure	150 psia [1034 kPa] ⁵						
Pressure Control Range	5 to 100% F.S.						
Resolution (measurement)	$\leq 0.1\%$ F.S.						
Temperature Coefficient							
Zero \pm	<table style="display: inline-table; border: none;"> <thead> <tr> <th style="text-align: left;"><i>Pressure</i></th> <th style="text-align: left;"><i>Flow</i></th> </tr> </thead> <tbody> <tr> <td>$\leq \pm 0.04\%$ F.S./°C</td> <td>$\leq \pm 0.05\%$ F.S./°C</td> </tr> <tr> <td>$\leq \pm 0.04\%$ Reading/°C</td> <td>$\leq \pm 0.08\%$ Reading/°C</td> </tr> </tbody> </table>	<i>Pressure</i>	<i>Flow</i>	$\leq \pm 0.04\%$ F.S./°C	$\leq \pm 0.05\%$ F.S./°C	$\leq \pm 0.04\%$ Reading/°C	$\leq \pm 0.08\%$ Reading/°C
<i>Pressure</i>	<i>Flow</i>						
$\leq \pm 0.04\%$ F.S./°C	$\leq \pm 0.05\%$ F.S./°C						
$\leq \pm 0.04\%$ Reading/°C	$\leq \pm 0.08\%$ Reading/°C						
Span \pm							
Warm Up Time	5 minutes						

² Includes controller error, linearity, hysteresis, and repeatability.

³ Includes the controller error only.

⁴ An overall metal braided shielded cable, properly grounded at both ends, is required during use.

⁵ Consistent with the overpressure limit of the transducer.

Physical Specifications

Burst Pressure	≥ 1500 psia [1.03×10^4 kPa]
Dimensions	3.81 cm x 12.07 cm (less fittings) x 14.1 cm max.
Fittings	Cajon [®] 4-VCR [®] male compatible, 8-VCR male compatible
Full Scale Ranges Pressure	10 torr [1.33×10^3 Pa] 20 torr [2.66×10^3 Pa] 50 torr [6.66×10^3 Pa] 100 torr [1.33×10^4 Pa] 1000 torr [1.33×10^5 Pa]
Flow	10, 20, 50, 100, 200, 500, 1000, 2000, 5000 sccm
Input Power	±15 VDC ±5%, 250 mA, maximum during first five seconds at start up, 200 mA at steady state
Maximum Cable Length	100 ft.
Overpressure Limit	45 psia [310 kPa] or 200% F.S., whichever is greater
Output Signals Flow Pressure	0 to 5 VDC 0 to 10 VDC initial configuration (0 to 5 VDC jumper selectable)
Setpoint Input	0 to 5 V or 0 to 10 V (matches the pressure signal output)
Pressure Transducer	Absolute pressure capacitance manometer
Valve Options Type Seat Material	Normally closed Kel-F [®] , Viton [®] , metal or Kalrez [®]
Surface Finish	<0.4 μm, Ra, electropolished
Weight	1.6 kg
Wetted Materials (excluding valve seat)	316L VIM/VAR stainless steel, Inconel [®] , Nickel, Elgiloy [®]

Environmental Specifications

Ambient Operating Temperature Range	0° to 50° C
Storage Temperature Range	-20° to 80° C
Storage Humidity Range	0 to 95% Relative Humidity, non-condensing

Trip Point Specifications

Trip Points	Two open collector transistors, adjustable from 1 to 100% full scale
Rated Current	30 VDC/250 mA
State	On above or below trip point; jumper selectable
Hysteresis	3% Full Scale (factory set)
Status LEDs	Green when the transistor is on
Settings	0 to 5 Volts corresponds to 1 to 100 % full scale

Due to continuing research and development activities, these product specifications are subject to change without notice.

Appendix B

Model Code

The options of your 649 unit are identified in the model code when you order the unit.

The model code is identified as follows:

649BGGGXXXYYYZAB

where:

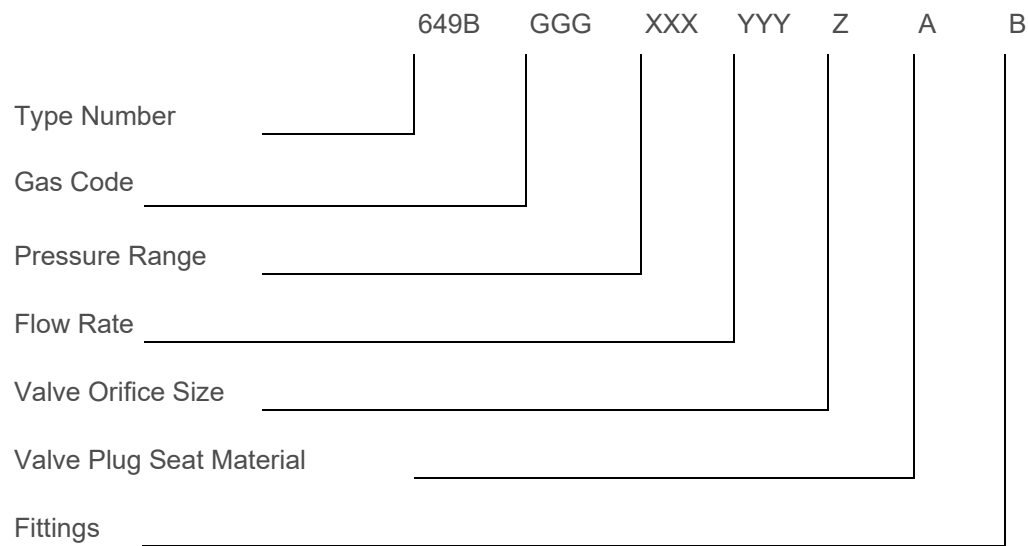

Type Number (649B)

This designates the model number of the instrument. 649B designates the ROHS compliant version of the 649B product.

Gas Code (GGG)

The gas code is indicated by a three digit code.

Gas Code	Ordering Code
Helium	001
Argon	004
Hydrogen	007
Nitrogen	013

Full Scale Pressure Range (XXX)

The full scale pressure range is indicated by a two digit/one letter code.

Full Scale Pressure Range	Ordering Code
10 torr [1.33×10^3 Pa]	11T
20 torr [2.66×10^3 Pa]	21T
50 torr [6.66×10^3 Pa]	51T
100 torr [1.33×10^4 Pa]	12T
1000 torr [1.33×10^5 Pa]	13T

Flow Rate Full Scale (YYY)

The flow rate full scale is indicated by a two digit/one letter code.

Flow Rate Full Scale	Ordering Code
10 sccm	11C
20 sccm	21C
50 sccm	51C
100 sccm	12C
200 sccm	22C
500 sccm	52C
1000 sccm	13C
2000 sccm	23C
5000 sccm	53C

Valve Orifice Size (Z)

The valve orifice size is designated by a single number or letter code. Refer to *Appendix B*, page 70, for more information.

Valve Orifice	Ordering Code
<100 sccm	A
200 sccm	1
1000 sccm	2
5000 sccm	3

Valve Plug Seat Material (A)

The valve plug seat material is specified by a single letter code.

Valve Plug Seat Material	Ordering Code
Metal	M
Viton	V
Kel-F	F
Kalrez	D

Fittings (B)

The choice of fittings is indicated by a single letter code.

Fittings	Ordering Code
Cajon 4-VCR, male	R
Cajon 8-VCR, male	T

Appendix C: Valve Orifice Selection

General Information

The 649B controller is available in four valve orifice sizes. You should confirm that the valve orifice in your 649B controller is the correct size for your application before you install it into your system. The orifice is *not* adjustable and is only replaceable at the factory.

This selection guide is valid with any valve plug seat material.

Checking the Valve Orifice Size

The valve orifice number is included in the model code number of your 649B controller. The nominal flow rate range for the orifice numbers are listed in Table 4. Refer to *Appendix B*, page 70, for a description of the model code.

Valve Orifice Size		
Orifice Size	Model Code Entry (Z)	Nominal Range (sccm of N ₂ with 760 torr [101.3 kPa] ΔP)
A	A	<100
1	1	200
2	2	1000
3	3	5000

Table 4 – Valve Orific Sizes

How To Verify the Orifice Selection

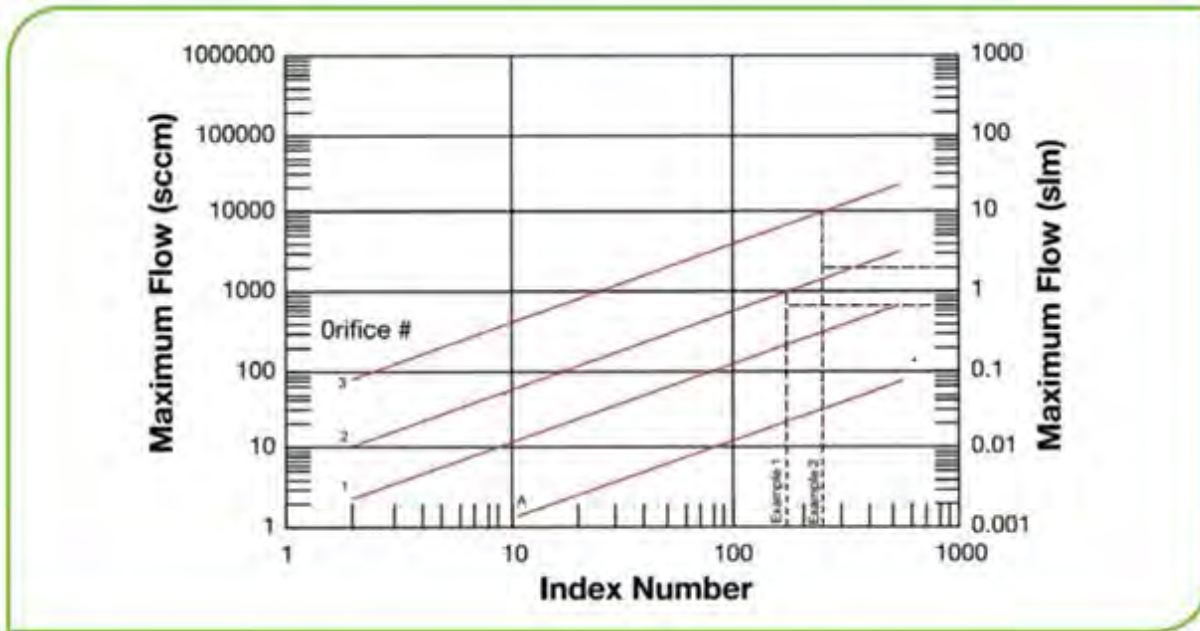

Figure 15 - Valve Orifice Index Number

		Differential Pressure (psi)										
		>50	50	30	15	8	4	2	1			0.5
Inlet Pressure (psia)	100	>585	585	480	355	265	190	135	95	65	5170	
	50	-	295	295	240	185	130	95	65	50	2585	
	30	-	-	175	175	140	100	75	50	40	1551	
	20	-	-	-	115	110	80	60	40	30	1034	
	15	-	-	-	90	90	70	50	35	25	776	
	10	-	-	-	-	60	55	40	30	20	517	
	5	-	-	-	-	-	30	25	20	15	259	
	2	-	-	-	-	-	-	10	10	9	103	
1	-	-	-	-	-	-	-	6	6	51.7		
		>2585	2585	1551	776	414	207	103	51.7	25.9		
		Differential Pressure (Torr)										

Table 5 - Valve Orifice Index Number

The flow through any orifice depends on the size of the orifice, the inlet and outlet pressures, and gas density. To simplify 649 orifice selection, use the following procedure:

1. On the Index Number Table 5, choose your inlet pressure from the column of pressures on the left—the pressure that will be applied to the inlet of your 649B. (Note that the values are absolute pressure.) Next, from the row of pressures at the top of that table, select your differential (delta) pressure – this is the inlet pressure minus your outlet pressure. Locate the Index Number – where your selected row and column intersect.
2. If you are using N₂, skip to step #3. For other gases, calculate the Density Correction Factor (DCF) by the following formula:

$$DCF = \sqrt{\frac{N_2 \text{ density}}{\text{user gas density}}}$$

Multiply this Density Correction Factor times the Index Number found in step 3, to determine your density corrected Index Number.

3. Go to the Orifice Selection Graph (Figure 15) and locate your Index Number along the bottom axis. Draw a vertical line at your Index Number. This line will intersect with the Max. Flow Rate lines for available valve orifices. Choose the orifice whose maximum flow rate exceeds your requirements.

Example 1

You want to control your process pressure at 5 psia, with a flow rate of 750 sccm of N₂. Your inlet pressure is 15 psig (30 psia) giving a differential pressure (delta P) of 25 psi. Your delta P of 25 psi gives an Index Number value of 175. Drawing a vertical line on the Orifice Selection Chart at 175 indicates Orifice #2 would be the best choice.

Example 2

You want to control a vacuum process at a pressure of 0.5 psia, with a flow rate of 2000 sccm of helium. Your inlet pressure is 15 psia, giving a differential pressure (delta P) of 15 psi, resulting in an uncorrected Index Number value of 90. The gas density correction for He is calculated as

$$DCF = \sqrt{\frac{N_2 \text{ density}}{\text{user gas density}}} = \sqrt{\frac{1.250 \text{ g/l}}{0.179 \text{ g/l}}} = 2.6$$

Multiplying 2.6 by 90 gives a density-corrected Index Number of 234. Drawing a vertical line on the Orifice Selection Chart at 234 indicates Orifice #3 would be the best choice.

Index

A

Accuracy, 67

Ambient temperature, 33, 69

C

Commands, priority, 54

Connector, I/O, 43-45

Control range, pressure, 47

Control system, 48

Customer support, 35

D

Differential pressure, 56, 67

Dimensions, 39-42

Downstream control, 43

E

Electrical information, 43

F

Fittings, 42, 67, 70

Flow arrow, 39, 40, 43

Flow output signal, 43, 46, 68

Flow path, 49

Flow range, 47

I

I/O connector, 43-44

Inlet pressure, 42, 56

Installation, 36

Integral control, 48, 50-51, 59, 67

L

Label, 56

M

Manual conventions, 35

Manual organization, 34-35

Measurement technique, 49

Model code, 70-72

Mounting, 38, 41-42

O

Optional input, 44-45

Orientation, 38, 57

Overpressure limit, 38, 42, 67

P

PI control, 48, 50-53, 59

Pinout, I/O connector, 44-45

Power, 68

Pressure control signal, 44, 64, 67

Pressure output range, 68

Pressure output signal, 44, 64, 67

Pressure, inlet, 42, 56

Process control, 55

Proportional control, 48, 50-51, 59, 67

R

Range, 47, 64, 67-68, 70, 73

Returning the product, 35-36

S

Safety procedures and precautions, 9-32

Setpoint, 43-46

Setpoint input, 48-54, 59-64

Setpoint recognition, 54

Span adjustment, 58

Specifications

environmental, 69

physical, 68

trip points, 69

T

Transducer board, 55, 61-62

Trip point action, 61

Trip point values, 60

Trip points, 55, 59-62, 69

Tuning, 48, 50-53, 59

U

Unpacking

opening, 36

V

Valve commands, 54

Valve orifice, 72-75

Valve test point, 44

Z

Zero

mass flow meter, 58-59

transducer, 57