

MKS Baratron® Type 631F High Temperature Pressure Transducer

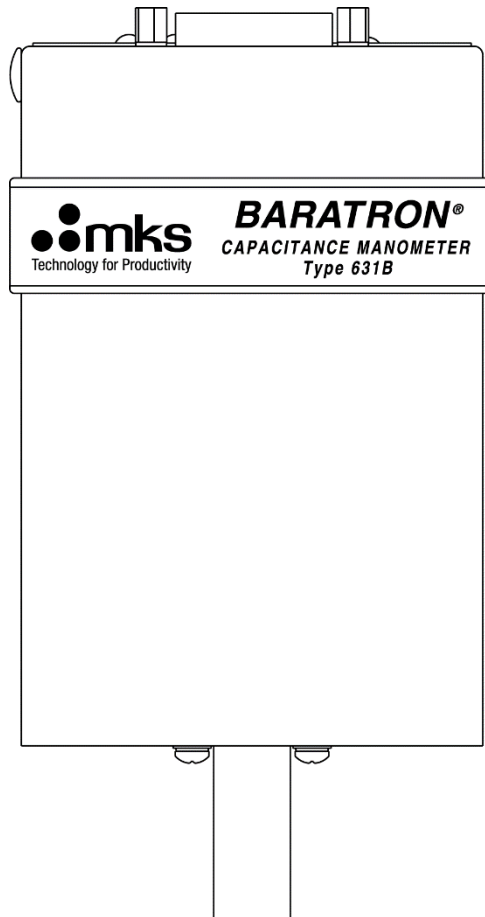

Copyright © 2021 by MKS Instruments, Inc.

All rights reserved. No part of this work may be reproduced or transmitted in any form or by any means, electronic or mechanical, including photocopying and recording, or by any information storage or retrieval system, except as may be expressly permitted in writing by MKS Instruments, Inc.

Printed in the United States of America

mksinst™ is a trademark and Baratron® is a registered trademark of MKS Instruments, Inc., Andover, MA, USA.

Swagelok®, VCR®, VCO®, and Ultra-Torr® are registered trademarks of Swagelok Company, Solon, OH, USA.

Tri-Clover® is a registered trademark of Tri-Clover, Inc., Kenosha, WI, USA.

Inconel® and Incoloy® are registered trademarks of Inco Alloys International, Inc., Huntington, WV, USA.

Protected by U.S. Patent Numbers 4785669 and 5625152. Foreign patents pending.

Some Baratron® products may not be exported to many end user countries without both US and local government export licenses under ECCN 2B230.

Table of Contents

Safety Information.....	1
Symbols Used in This Instruction Manual	1
Symbols Found on the Unit.....	2
Safety Procedures and Precautions.....	3
Sicherheitshinweise für den Druckmeßumformer	5
In dieser Betriebsanleitung vorkommende Symbole.....	5
Erklärung der am Gerät angebrachten Symbole.....	6
Sicherheitsvorschriften und Vorsichtsmaßnahmen	7
Informations relatives à la sécurité pour le transducteur de pression.....	9
Symboles utilisés dans ce manuel d'utilisation.....	9
Symboles apparaissant sur l'unité.....	10
Mesures de sécurité et précautions	11
Medidas de seguridad del transductor de presión.....	13
Símbolos usados en este manual de instrucciones.....	13
Símbolos hallados en la unidad	14
Procedimientos y precauciones de seguridad	15
Chapter One: General Information	17
Introduction	17
How This Manual is Organized.....	18
Customer Support.....	19
Chapter Two: Installation	21
How To Unpack the Type 631F Unit	21
Unpacking Checklist	21
Interface Cables	22
Cable to Connect to the Power Supply.....	23
Product Location and Requirements.....	23
Environmental Requirements	24
Setup	25

General.....	25
Environmental Considerations	25
Sensor	26
Piping Considerations and Port Connections	27
General.....	27
Sensor Fittings	27
Chapter Three: Overview	29
Sensor	29
Signal Conditioner.....	29
Instrument Components and Dimensions.....	29
Interface Connector	33
Pressure Output.....	34
Overpressure Considerations.....	34
Labels.....	34
Wiring Diagram Label.....	34
“Caution Hot” Label.....	34
Serial Number Label.....	35
Chapter Four: Operation	37
How To Zero the Type 631 Transducer	37
How To Adjust the Zero Potentiometer	38
How To Adjust the Coarse Zero Switch.....	39
Heater Status LEDs and Heater Alarm Relay.....	40
Over-Temperature Protection.....	40
Chapter Five: Optional Relay System	43
General Information.....	43
Trip Point Parameters	43
Trip Point Values.....	43
Trip Point Direction.....	44
Chapter Six: Maintenance and Troubleshooting	47
General Maintenance	47
Troubleshooting.....	48

High, Low, or Erratic Output, or No Output at All	48
Appendix A: Product Specifications	49
Physical Specifications	49
Performance Specifications	50
Environmental Specifications	50
Appendix B: Model Code Explanation.....	51
Model Code	51
Index	55

List of Figures and Tables

Figures

Figure 1: Recommended Orientation of the Type 631F Transducer	26
Figure 2: Top View of the Type 631F Transducer Without Optional Relay System.....	30
Figure 3: Top View of the Type 631F Transducer With Optional Relay System.....	31
Figure 4: Dimensions of the Type 631F Transducer	32
Figure 5: Wiring Diagram Label	34
Figure 6: The “Caution Hot” Label	35
Figure 7: The Serial Number Label.....	35
Figure 8: Location of the Trip Point Adjustment Pots and Trip Point Signal Output	44
Figure 9: LED and Relay State When Trip Point Direction Set Above Trip Point Value	45
Figure 10: LED and Relay State When Trip Point Direction Set Below Trip Point Value	45

Tables

Table 1: Definition of Symbols Found on the Unit	2
Tabelle 2: Bedeutung der am Gerät angebrachten Symbole	6
Tableau 3: Définition des symboles apparaissant sur l'unité	10
Tabla 4: Definición de los símbolos hallados en la unidad	14
Table 5: Interface Cables	22
Table 6: Pinout of the Interface Connector (J1)	33
Table 7: Highest Pressures Suggested for Proper Zero Adjustment.....	38
Table 8: Over-Temperature Cutoff Value	41
Table 9: Conditions and resulting status LEDs and heater alarm relay output.	41

Safety Information

Symbols Used in This Instruction Manual

Definitions of WARNING, CAUTION, and NOTE messages used throughout the manual.

Warning  The **WARNING** sign denotes a hazard. It calls attention to a procedure, practice, condition, or the like, which, if not correctly performed or adhered to, could result in injury to personnel.

Caution  The **CAUTION** sign denotes a hazard. It calls attention to an operating procedure, practice, or the like, which, if not correctly performed or adhered to, could result in damage to or destruction of all or part of the product.

Note  The **NOTE** sign denotes important information. It calls attention to a procedure, practice, condition, or the like, which is essential to highlight.

Symbols Found on the Unit

The following table describes symbols that may be found on the unit.





















Definition of Symbols Found on the Unit			
  IEC 417, No.5008	 Off (Supply) IEC 417, No.5008	  IEC 417, No.5008	 Protective earth (ground) IEC 417, No.5008
   IEC 417, No.5032	  IEC 417, No.5032	  IEC 417, No.5032	 Alternating current IEC 417, No.5032
 Both direct and alternating current IEC 417, No.5033-a	  IEC 417, No.5032	 Three phase alternating current IEC 617-2 No.020206	
 Caution, refer to accompanying documents ISO 3864, No.B.3.1	 Caution, risk of electric shock ISO 3864, No.B.3.6	 Caution, hot surface IEC 417, No.5041	

Table 1: Definition of Symbols Found on the Unit

Safety Procedures and Precautions

The following general safety precautions must be observed during all phases of operation of this instrument. Failure to comply with these precautions or with specific warnings elsewhere in this manual violates safety standards of intended use of the instrument and may impair the protection provided by the equipment. MKS Instruments, Inc. assumes no liability for the customer's failure to comply with these requirements.

DO NOT SUBSTITUTE PARTS OR MODIFY INSTRUMENT

Do not install substitute parts or perform any unauthorized modification to the instrument. Return the instrument to an MKS Calibration and Service Center for service and repair to ensure that all safety features are maintained.

SERVICE BY QUALIFIED PERSONNEL ONLY

Operating personnel must not remove instrument covers. Component replacement and internal adjustments must be made by qualified service personnel only.

DO NOT OPERATE IN EXPLOSIVE ATMOSPHERES

To avoid explosion, do not operate this product in an explosive atmosphere unless it has been specifically certified for such operation.

USE PROPER FITTINGS AND TIGHTENING PROCEDURES

All instrument fittings must be consistent with instrument specifications, and compatible with the intended use of the instrument. Assemble and tighten fittings according to manufacturer's directions.

CHECK FOR LEAK-TIGHT FITTINGS

Before proceeding to instrument setup, carefully check all plumbing connections to the instrument to ensure leak-tight installation.

OPERATE AT SAFE INLET PRESSURES

This unit should never be operated at pressures higher than the rated maximum pressure (refer to the product specifications for the maximum allowable pressure).

INSTALL A SUITABLE BURST DISC

When operating from a pressurized gas source, a suitable burst disc should be installed in the vacuum system to prevent system explosion should the system pressure rise.

KEEP THE UNIT FREE OF CONTAMINANTS

Do not allow contaminants of any kind to enter the unit before or during use. Contamination such as dust, dirt, lint, glass chips, and metal chips may permanently damage the unit.

USE CAUTION WHEN TOUCHING THE TRANSDUCER

The transducer (especially the bottom plate and tube) becomes hot when the system is in operation.

Sicherheitshinweise für den Druckmeßumformer

In dieser Betriebsanleitung vorkommende Symbole

Bedeutung der mit WARNUNG!, VORSICHT! und HINWEIS gekennzeichneten Absätze in dieser Betriebsanleitung.

Warnung!



Das Symbol **WARNUNG!** weist auf eine Gefahr für das Bedienpersonal hin. Es macht auf einen Arbeitsablauf, eine Arbeitsweise, einen Zustand oder eine sonstige Gegebenheit aufmerksam, deren unsachgemäße Ausführung bzw. ungenügende Berücksichtigung zu Verletzungen führen kann.

Vorsicht!



Das Symbol **VORSICHT!** weist auf eine Gefahr für das Gerät hin. Es macht auf einen Bedienungsablauf, eine Arbeitsweise oder eine sonstige Gegebenheit aufmerksam, deren unsachgemäße Ausführung bzw. ungenügende Berücksichtigung zu einer Beschädigung oder Zerstörung des Gerätes oder von Teilen des Gerätes führen kann.

Hinweis



Das Symbol **HINWEIS** macht auf wichtige Informationen bezüglich eines Arbeitsablaufs, einer Arbeitsweise, eines Zustands oder einer sonstige Gegebenheit aufmerksam.

Erklärung der am Gerät angebrachten Symbole

Nachstehender Tabelle sind die Bedeutungen der Symbole zu entnehmen, die am Gerät angebracht sein können.















Bedeutung der am Gerät angebrachten Symbole			
			
Ein (Energie) IEC 417, No.5007	Aus (Energie) IEC 417, No.5008	Erdanschluß IEC 417, No.5017	Schutzleiteranschluß IEC 417, No.5019
			
Masseanschluß IEC 417, No.5020	Aquipotential- anschluß IEC 417, No.5021	Gleichstrom IEC 417, No.5031	Wechselstrom IEC 417, No.5032
			
Gleich- oder Wechselstrom IEC 417, No.5033-a	Durchgängige doppelte oder verstärkte Isolierung IEC 417, No.5172-a	Dreileiter- Wechselstrom (Drehstrom) IEC 617-2, No.020206	
			
Warnung vor einer Gefahrenstelle (Achtung, Dokumen- tation beachten) ISO 3864, No.B.3.1	Warnung vor gefährlicher elektrischer Spannung ISO 3864, No.B.3.6	Höhere Temperatur an leicht zugänglichen Teilen IEC 417, No.5041	

Tabelle 2: Bedeutung der am Gerät angebrachten Symbole

Sicherheitsvorschriften und Vorsichtsmaßnahmen

Folgende allgemeine Sicherheitsvorschriften sind während allen Betriebsphasen dieses Gerätes zu befolgen. Eine Mißachtung der Sicherheitsvorschriften und sonstiger Warnhinweise in dieser Betriebsanleitung verletzt die für dieses Gerät und seine Bedienung geltenden Sicherheitsstandards, und kann die Schutzvorrichtungen an diesem Gerät wirkungslos machen. MKS Instruments, Inc. haftet nicht für Mißachtung dieser Sicherheitsvorschriften seitens des Kunden.

Niemals Teile austauschen oder Änderungen am Gerät vornehmen!

Ersetzen Sie keine Teile mit baugleichen oder ähnlichen Teilen, und nehmen Sie keine eigenmächtigen Änderungen am Gerät vor. Schicken Sie das Gerät zwecks Wartung und Reparatur an den MKS-Kalibrierungs- und -Kundendienst ein. Nur so wird sichergestellt, daß alle Schutzvorrichtungen voll funktionsfähig bleiben.

Wartung nur durch qualifizierte Fachleute!

Das Auswechseln von Komponenten und das Vornehmen von internen Einstellungen darf nur von qualifizierten Fachleuten durchgeführt werden, niemals vom Bedienpersonal.

Vorsicht beim Arbeiten mit gefährlichen Stoffen!

Wenn gefährliche Stoffe verwendet werden, muß der Bediener die entsprechenden Sicherheitsvorschriften genauestens einhalten, das Gerät, falls erforderlich, vollständig spülen, sowie sicherstellen, daß der Gefahrstoff die am Gerät verwendeten Materialien, insbesondere Dichtungen, nicht angreift.

Spülen des Gerätes mit Gas!

Nach dem Installieren oder vor dem Ausbau aus einem System muß das Gerät unter Einsatz eines reinen Trockengases vollständig gespült werden, um alle Rückstände des Vorgängermediums zu entfernen.

Anweisungen zum Spülen des Gerätes

Das Gerät darf nur unter einer Ablufthaube gespült werden. Schutzhandschuhe sind zu tragen.

Gerät nicht zusammen mit explosiven Stoffen, Gasen oder Dämpfen benutzen!

Um der Gefahr einer Explosion vorzubeugen, darf dieses Gerät niemals zusammen mit (oder in der Nähe von) explosiven Stoffen aller Art eingesetzt werden, sofern es nicht ausdrücklich für diesen Zweck zugelassen ist.

Anweisungen zum Installieren der Armaturen!

Alle Anschlußstücke und Armaturenteile müssen mit der Gerätespezifikation übereinstimmen, und mit dem geplanten Einsatz des Gerätes kompatibel sein. Der Einbau, insbesondere das Anziehen und Abdichten, muß gemäß den Anweisungen des Herstellers vorgenommen werden.

Verbindungen auf Undichtigkeiten prüfen!

Überprüfen Sie sorgfältig alle Verbindungen der Vakuumkomponenten auf undichte Stellen.

Gerät nur unter zulässigen Anschlußdrücken betreiben!

Betreiben Sie das Gerät niemals unter Drücken, die den maximal zulässigen Druck (siehe Produktspezifikationen) übersteigen.

Geeignete Berstscheibe installieren!

Wenn mit einer unter Druck stehenden Gasquelle gearbeitet wird, sollte eine geeignete Berstscheibe in das Vakuumsystem installiert werden, um eine Explosionsgefahr aufgrund von steigendem Systemdruck zu vermeiden.

Verunreinigungen im Gerät vermeiden!

Stellen Sie sicher, daß Verunreinigungen jeglicher Art weder vor dem Einsatz noch während des Betriebs in das Instrumenteninnere gelangen können. Staub- und Schmutzpartikel, Glassplitter oder Metallspäne können das Gerät dauerhaft beschädigen oder Prozeß und Meßwerte verfälschen.

Bei Geräten mit Temperaturkontrolle korrekte Anwärmzeit einhalten!

Temperaturkontrollierte Geräte arbeiten nur dann gemäß ihrer Spezifikation, wenn genügend Zeit zum Erreichen und Stabilisieren der Betriebstemperatur eingeräumt wird. Kalibrierungen und Nulleinstellungen sollten daher nur nach Abschluß des Anwärmvorgangs durchgeführt werden.

Informations relatives à la sécurité pour le transducteur de pression

Symboles utilisés dans ce manuel d'utilisation

Définitions des indications AVERTISSEMENT, ATTENTION, et REMARQUE utilisées dans ce manuel.

Avertissement



L'indication **AVERTISSEMENT** signale un danger pour le personnel. Elle attire l'attention sur une procédure, une pratique, une condition, ou toute autre situation présentant un risque d'accident pour le personnel, en cas d'exécution incorrecte ou de non respect des consignes.

Attention



L'indication **ATTENTION** signale un danger pour l'appareil. Elle attire l'attention sur une procédure d'exploitation, une pratique, ou toute autre situation, présentant un risque d'endommagement ou de destruction d'une partie ou de la totalité de l'appareil, en cas d'exécution incorrecte ou de non respect des consignes.

Remarque



L'indication **REMARQUE** signale une information importante. Elle attire l'attention sur une procédure, une pratique, une condition, ou toute autre situation, présentant un intérêt particulier.

Symboles apparaissant sur l'unité

Le tableau suivant décrit les symboles pouvant apparaître sur l'unité.















Définition des symboles apparaissant sur l'unité			
			
Marche (sous tension) IEC 417, No.5007	Arrêt (hors tension) IEC 417, No.5008	Terre (masse) IEC 417, No.5017	Terre de protection (masse) IEC 417, No.5019
			
Masse IEC 417, No.5020	Equipotentialité IEC 417, No.5021	Courant continu IEC 417, No.5031	Courant alternatif IEC 417, No.5032
			
Courant continu et alternatif IEC 417, No.5033-a	Matériel de classe II IEC 417, No.5172-a	Courant alternatif triphase IEC 617-2, No.020206	
			
Attention : se reporter à la documentation ISO 3864, No.B.3.1	Attention : risque de choc électrique ISO 3864, No.B.3.6	Attention : surface brûlante IEC 417, No.5041	

Tableau 3: Définition des symboles apparaissant sur l'unité

Mesures de sécurité et précautions

Prendre les précautions générales de sécurité suivantes pendant toutes les phases d'exploitation de cet appareil. Le non respect de ces précautions ou des avertissements contenus dans ce manuel constitue une violation des normes de sécurité relatives à l'utilisation de l'appareil et peut diminuer la protection fournie par l'appareil. MKS Instruments, Inc. n'assume aucune responsabilité concernant le non respect des consignes par les clients.

PAS DE SUBSTITUTION DE PIÈCES OU DE MODIFICATION DE L'APPAREIL

Ne pas installer des pièces de substitution ou effectuer des modifications non autorisées sur l'appareil. Renvoyer l'appareil à un centre de service et de calibrage MKS pour tout dépannage ou réparation afin de garantir le l'intégrité des dispositifs de sécurité.

DÉPANNAGE UNIQUEMENT PAR DU PERSONNEL QUALIFIÉ

Le personnel d'exploitation ne doit pas essayer de remplacer des composants ou de faire des réglages internes. Tout dépannage doit être uniquement effectué par du personnel qualifié.

PRÉCAUTION EN CAS D'UTILISATION AVEC DES PRODUITS DANGEREUX

Si des produits dangereux sont utilisés, l'utilisateur est responsable de la prise des mesures de précaution appropriées, de la purge complète de l'appareil quand cela est nécessaire, et de la garantie que les produits utilisés sont compatibles avec les composants de cet appareil, y compris les matériaux d'étanchéité.

PURGE DE L'APPAREIL

Après l'installation de l'unité, ou avant son enlèvement d'un système, purger l'unité complètement avec un gaz propre et sec afin d'éliminer toute trace du produit de flux utilisé précédemment.

UTILISATION DES PROCÉDURES APPROPRIÉES POUR LA PURGE

Cet appareil doit être purgé sous une hotte de ventilation, et il faut porter des gants de protection.

PAS D'EXPLOITATION DANS UN ENVIRONNEMENT EXPLOSIF

Pour éviter toute explosion, ne pas utiliser cet appareil dans un environnement explosif, sauf en cas d'homologation spécifique pour une telle exploitation.

UTILISATION D'ÉQUIPEMENTS APPROPRIÉS ET PROCÉDURES DE SERRAGE

Tous les équipements de l'appareil doivent être cohérents avec ses spécifications, et compatibles avec l'utilisation prévue de l'appareil. Assembler et serrer les équipements conformément aux directives du fabricant.

VÉRIFICATION DE L'ÉTANCHÉITÉ DES CONNEXIONS

Vérifier attentivement toutes les connexions des composants pour le vide afin de garantir l'étanchéité de l'installation.

EXPLOITATION AVEC DES PRESSIONS D'ENTRÉE NON DANGEREUSES

Ne jamais utiliser des pressions supérieures à la pression nominale maximum (se reporter aux spécifications de l'unité pour la pression maximum admissible).

INSTALLATION D'UN DISQUE D'ÉCHAPPEMENT ADAPTÉ

En cas d'exploitation avec une source de gaz pressurisé, installer un disque d'échappement adapté dans le système à vide, afin d'éviter une explosion du système en cas d'augmentation de la pression.

MAINTIEN DE L'UNITÉ À L'ABRI DES CONTAMINATIONS

Ne pas laisser des produits contaminants pénétrer dans l'unité avant ou pendant l'utilisation. Des produits contaminants tels que des poussières et des fragments de tissu, de glace et de métal peuvent endommager l'unité d'une manière permanente ou contaminer le processus.



RESPECT DU TEMPS D'ÉCHAUFFEMENT APPROPRIÉ POUR LES UNITÉS À TEMPÉRATURE CONTRÔLÉE

Les unités à température contrôlée atteignent leurs spécifications uniquement quand on leur laisse un temps suffisant pour atteindre d'une manière stable la température d'exploitation. Ne pas remettre à zéro ou calibrer l'unité tant que l'échauffement n'est pas terminé.

Medidas de seguridad del transductor de presión

Símbolos usados en este manual de instrucciones

Definiciones de los mensajes de advertencia, precaución y de las notas usados en el manual.

Advertencia		El símbolo de advertencia indica la posibilidad de que se produzcan daños personales. Pone de relieve un procedimiento, práctica, estado, etc. que en caso de no realizarse u observarse correctamente puede causar daños personales.
Precaución		El símbolo de precaución indica la posibilidad de producir daños al equipo. Pone de relieve un procedimiento operativo, práctica, estado, etc. que en caso de no realizarse u observarse correctamente puede causar daños o la destrucción total o parcial del equipo.
Nota		El símbolo de notas indica información de importancia. Este símbolo pone de relieve un procedimiento, práctica o condición cuyo conocimiento es esencial destacar.

Símbolos hallados en la unidad

La tabla siguiente contiene los símbolos que puede hallar en la unidad.















Definición de los símbolos hallados en la unidad			
 Encendido (alimentación eléctrica) IEC 417, N° 5007	 Apagado (alimentación eléctrica) IEC 417, N° 5008	 Puesta a tierra IEC 417, N° 5017	 Protección a tierra IEC 417, N° 5019
 Caja o chasis IEC 417, N° 5020	 Equipotencialidad IEC 417, N° 5021	 Corriente continua IEC 417, N° 5031	 Corriente alterna IEC 417, N° 5032
 Corriente continua y alterna IEC 417, N° 5033-a	 Equipo de clase II IEC 417, N° 5172-a	 Corriente alterna trifásica IEC 617-2, N° 020206	
 Precaución. Consulte los documentos adjuntos ISO 3864, N° B.3.1	 Precaución. Riesgo de descarga eléctrica ISO 3864, N° B.3.6	 Precaución. Superficie caliente IEC 417, N° 5041	

Tabla 4: Definición de los símbolos hallados en la unidad

Procedimientos y precauciones de seguridad

Las precauciones generales de seguridad descritas a continuación deben observarse durante todas las etapas de funcionamiento del instrumento. La falta de cumplimiento de dichas precauciones o de las advertencias específicas a las que se hace referencia en el manual, constituye una violación de las normas de seguridad establecidas para el uso previsto del instrumento y podría anular la protección proporcionada por el equipo. Si el cliente no cumple dichas precauciones y advertencias, MKS Instruments, Inc. no asume responsabilidad legal alguna.

NO UTILICE PIEZAS NO ORIGINALES O MODIFIQUE EL INSTRUMENTO

No instale piezas que no sean originales ni modifique el instrumento sin autorización. Para asegurar el correcto funcionamiento de todos los dispositivos de seguridad, envíe el instrumento al Centro de servicio y calibración de MKS toda vez que sea necesario repararlo o efectuar tareas de mantenimiento.

LAS REPARACIONES DEBEN SER EFECTUADAS ÚNICAMENTE POR TÉCNICOS AUTORIZADOS

Los operarios no deben intentar reemplazar los componentes o realizar tareas de ajuste en el interior del instrumento. Las tareas de mantenimiento o reparación deben ser realizadas únicamente por personal autorizado.

TENGA CUIDADO CUANDO TRABAJE CON MATERIALES TÓXICOS

Cuando se utilicen materiales tóxicos, es responsabilidad de los operarios tomar las medidas de seguridad correspondientes, purgar totalmente el instrumento cuando sea necesario y comprobar que el material utilizado sea compatible con los materiales del instrumento e inclusive, con todos los materiales de sellado.

PURGUE EL INSTRUMENTO

Una vez instalada la unidad o antes de retirarla del sistema, purgue completamente la unidad con gas limpio y seco para eliminar todo resto de la sustancia líquida empleada anteriormente.

USE PROCEDIMIENTOS ADECUADOS PARA REALIZAR LA PURGA

El instrumento debe purgarse debajo de una campana de ventilación y deben utilizarse guantes protectores.

NO HAGA FUNCIONAR EL INSTRUMENTO EN AMBIENTES CON RIESGO DE EXPLOSIÓN

Para evitar que se produzcan explosiones, no haga funcionar este instrumento en un ambiente con riesgo de explosiones, excepto cuando el mismo haya sido certificado específicamente para tal uso.

USE ACCESORIOS ADECUADOS Y REALICE CORRECTAMENTE LOS PROCEDIMIENTOS DE AJUSTE

Todos los accesorios del instrumento deben cumplir las especificaciones del mismo y ser compatibles con el uso que se debe dar al instrumento. Arme y ajuste los accesorios de acuerdo con las instrucciones del fabricante.

COMPRUEBE QUE LAS CONEXIONES SEAN A PRUEBA DE FUGAS

Inspeccione cuidadosamente las conexiones de los componentes de vacío para comprobar que hayan sido instalados a prueba de fugas.

HAGA FUNCIONAR EL INSTRUMENTO CON PRESIONES DE ENTRADA SEGURAS

No haga funcionar nunca el instrumento con presiones superiores a la máxima presión nominal (en las especificaciones del instrumento hallará la presión máxima permitida).

INSTALE UNA CÁPSULA DE SEGURIDAD ADECUADA

Cuando el instrumento funcione con una fuente de gas presurizado, instale una cápsula de seguridad adecuada en el sistema de vacío para evitar que se produzcan explosiones cuando suba la presión del sistema.

MANTENGA LA UNIDAD LIBRE DE CONTAMINANTES

No permita el ingreso de contaminantes en la unidad antes o durante su uso. Los productos contaminantes tales como polvo, suciedad, pelusa, lascas de vidrio o virutas de metal pueden dañar irreparablemente la unidad o contaminar el proceso.

CALIENTE ADECUADAMENTE LAS UNIDADES CONTROLADAS POR MEDIO DE TEMPERATURA

Las unidades controladas por medio de temperatura funcionarán de acuerdo con las especificaciones sólo cuando se las caliente durante el tiempo suficiente para permitir que lleguen y se estabilicen a la temperatura de operación indicada. No calibre la unidad y no la ponga en cero hasta que finalice el procedimiento de calentamiento.

Chapter One: General Information

Introduction

Note



Some Baratron® products may not be exported to many end user countries without both US and local government export licenses under ECCN 2B230.

The MKS Baratron® Type 631F Absolute Pressure Transducer¹ is part of the MKS family of RoHS (Restriction of Hazardous Substances)-compliant, general purpose pressure transducers designed to provide accurate, reliable and repeatable pressure measurements from 1000 Torr down to 1 Torr, Full Scale (F.S.). The 631F is temperature-controlled to prevent contamination build-up and is available in either of two operating temperatures: 150° C and 200° C. These instruments have a small footprint and self-contained signal conditioning electronics mounted directly above the sensor. The precision pressure transducer operates on a variable capacitance technique² and requires ±15 VDC input to provide a 0 to 10 VDC output linear with pressure over the sensor's measurement range.

The 631F transducer is available with an optional trip point relay system. The relay system provides two (2) internally-mounted solid-state trip point relays with user adjustable pressure conditions that will turn ON or OFF each solid state relay. The trip point relay system includes a status LED, trip point value adjustment, direction selection and signal access for each of the two trip points.

The 631F pressure transducer is comprised of a sensor and signal conditioner. An MKS or compatible power supply is required to complete the pressure-to-electronic output conversion. A power supply/readout can also be used to provide a direct pressure display; the necessary Y-type cables are available from MKS.

The 631F transducer measures absolute pressure, so only the measurement port has a connector. During production, the reference port (P_R) is pumped down to a pressure less than 10⁻⁷ Torr, and outgassed thoroughly. A chemical getter is added to maintain the low pressure, and the port is permanently sealed.

Temperature control of the transducer minimizes the effects of ambient or process temperature variations typically encountered in process line environments. The sensor temperature is continually monitored; two status LEDs provide visual indication of the unit's temperature control status. The LED labeled "Htr Fail Status" is normally off. If the sensor heater fails, the LED becomes red and the associated relay becomes de-energized. The LED labeled "At Temp Status" is yellow while the unit heats up and green when the unit is at the correct temperature. (The unit requires a warm up time of two hours before any pressure data should be taken.)

Using the latest single sided, dual-electrode Inconel® sensor design, coupled with low impedance, fixed-frequency bridge signal conditioner, these instruments are capable of withstanding high

¹ U.S. Patent No. 5625152.

² U.S. Patent No. 4785669.

overpressure conditions (45 psia). The high overpressure limit, coupled with the high temperature operation, ensures maximum zero stability. The 631F transducer diaphragm design results in extremely low hysteresis and the ability to specify a $\pm 0.50\%$ accuracy as a percentage of Reading instead of as a percentage of Full Scale. Since the accuracy is based on a percentage of Reading, the transducer can be used over a wide dynamic measuring range without the need for re-ranging, thus it provides accurate process monitoring over a variety of operating conditions.

This product can be used for pressure and vacuum measurements with a wide variety of process gases, including (but not limited to) toxic, pyrophoric, and oxidizing materials such as silane (SiH_4), dichlorosilane ($\text{Cl}_2\text{H}_2\text{Si}$), trichlorosilane (Cl_3HSi), anhydrous ammonia (NH_3), ozone (O_3), and de-ionized water vapor (DIW). However, it is not recommended for use with corrosive or explosive gases, so please contact the MKS Applications group or your local MKS Account Manager if you plan to use the product with such gases.

This product contains electronic components made with non-toxic metals, and the packaging materials are recyclable plastics. However, at the end of life of the product, decommissioning must be performed in accordance with your local environmental regulations in consideration of the chemicals and gases that this product has been exposed to.

How This Manual is Organized

This manual is designed to provide instructions on how to set up, install, and operate a Type 631F unit.

Before installing your Type 631F unit in a system and/or operating it, carefully read and familiarize yourself with all precautionary notes in the *Safety Messages and Procedures* section at the front of this manual. In addition, observe and obey all WARNING and CAUTION notes provided throughout the manual.

Chapter One, *General Information*, (this chapter) introduces the product and describes the organization of the manual.

Chapter Two, *Installation*, explains the environmental requirements and describes how to mount the instrument in your system.

Chapter Three, *Overview*, gives a brief description of the instrument and its functionality.

Chapter Four, *Operation*, describes how to use the 631F unit and explains all the functions and features.

Chapter Five, *Optional Trip Point Relay System*, discusses the optional relay system and its parameters, including measuring and adjusting the trip point values and specifying the trip point direction.

Chapter Six, *Maintenance and Troubleshooting*, provides a few maintenance recommendations and a brief troubleshooting section. The Type 631F transducer is highly reliable and requires little maintenance.

Appendix A, *Product Specifications*, lists the specifications of the instrument.

Appendix B, *Model Code Explanation*, describes the model code.

Customer Support

Standard maintenance and repair services are available at all of our regional MKS Calibration and Service Centers, listed on the back cover. In addition, MKS accepts the instruments of other manufacturers for recalibration using the Primary and Transfer Standard calibration equipment located at all of our regional service centers. Should any difficulties arise in the use of your Type 631F instrument, or to obtain information about companion products MKS offers, contact any authorized MKS Calibration and Service Center. If it is necessary to return the instrument to MKS, please obtain an RMA Number (Return Material Authorization Number) from the MKS Calibration and Service Center before shipping. The RMA Number expedites handling and ensures proper servicing of your instrument.

Please refer to the inside of the back cover of this manual for a list of MKS Calibration and Service Centers.

Warning



All returns to MKS Instruments must be free of harmful, corrosive, radioactive, or toxic materials.

This page intentionally left blank.

Chapter Two: Installation

How To Unpack the Type 631F Unit

MKS has carefully packed the Type 631F unit so that it will reach you in perfect operating order. Upon receiving the unit, however, you should check for defects, cracks, broken connectors, etc., to be certain that damage has not occurred during shipment.

Note



Do *not* discard any packing materials until you have completed your inspection and are sure the unit arrived safely.

If you find any damage, notify your carrier and MKS immediately. If it is necessary to return the unit to MKS, obtain an RMA Number (Return Material Authorization Number) from the MKS Service Center before shipping. Please refer to the inside of the back cover of this manual for a list of MKS Calibration and Service Centers.

Caution



Only qualified individuals should perform the installation and any user adjustments. They must comply with all the necessary ESD and handling precautions while installing and adjusting the instrument. Proper handling is essential when working with all highly sensitive precision electronic instruments.

Unpacking Checklist

Standard Equipment:

- Type 631F Unit

Optional Equipment:

- Interface cables, refer to *Interface Cables*, page 22, for details
- Electrical Connector Accessories Kit: 631F-K1 (contains a mating connector)
- MKS Type PR4000B Electronic Display Unit
- All MKS automatic pressure controllers (Type 651, 1651, and others)

Note



The Type 651 pressure controller must include the high power supply option (2.0 Amperes) to work with a 631F transducer. A Type PR4000B must also be equipped with the 1.5 Ampere output to be used with this Baratron.

Interface Cables

MKS offers the following interface cables to connect the 631F unit to your system.

Interface Cables	
Cable Number	Number of Power Supplies
RCB631-1- xx	1
RCB631S-1- xx	1
<i>xx designates the length of the cable, in feet</i>	

Table 5: Interface Cables

Cable to Connect to the Power Supply

The 631F transducer is powered by a single ± 15 VDC power supply for both the electronics and heater. The cable connection to the 631F transducer via the Interface connector is shown in Figure 2: Top View of the Type 631F Transducer, page 30. Refer to Table 6: Pinout of the Interface Connector (J1), page 33, for the complete list of pin assignments for the Interface connector.

Product Location and Requirements

- Voltage: ± 15 VDC ($\pm 5\%$)
- Current: 1.0 Amp, maximum for the heater and electronics
- Overpressure limits: 45 psia or 120% of sensor Full Scale, whichever is greater
- Mount the Type 631F transducer components correctly: refer to Figure 1: Recommended Orientation of the Type 631F Transducer, page 26, for the recommended orientation of the sensor
- Maintain a solid system ground for proper operation and safety to personnel
- Isolate the unit from vibration

Keep the unit free from vibration. The diaphragm may be susceptible to resonance when there is not enough gas present to dampen the effects of vibration. The 1 Torr Full Scale units are the most sensitive. Any vibration that *does* exist should be isolated from the unit with vibration isolation mounting and a bellows coupling.
- Warm up Time: 2 hours

Environmental Requirements

Caution



DO NOT use a thermal blanket on the 631F unit. The 631F transducer is designed to maintain its specified operating temperature without external assistance.

- Operating ambient temperature:

150° C units: 10° to 50° C (50° to 122° F)

200° C units: 10° to 50° C (50° to 122° F)

Caution



Airflow of at least 50 ft/min is REQUIRED for 150° C units if the ambient temperature is 45° to 50° C (113 to 122°F).

Airflow of at least 150 ft/min is REQUIRED for 200° C units if the ambient temperature is 40° to 50° C (104 to 122°F).

- Ventilation requirements include sufficient air circulation

Caution



All high temperature equipment, including the 631F transducer, requires sufficient air circulation to prevent heat buildup. If the 631F transducer is placed in an environment with still air or insufficient air circulation, the temperature of the air surrounding the transducer will rise. You must provide sufficient air circulation to prevent heat build up around the 631F transducer.

- Storage Humidity Range: 25% to 95% relative humidity, non-condensing
- Storage Temperature Range: -20° to +80° C (-4° to 176° F)

Setup

General

To obtain maximum accuracy from your Type 631F transducer, be sure the interconnecting piping and the transducer components themselves are properly installed. Some general guidelines are:

- Mount the transducer such that vibration, shock, and temperature fluctuations are minimized, and that the product's inlet always points downward or horizontally.
- Minimize interconnecting piping
- Ensure adequate room to maintain environmental requirements and safety considerations, and to provide easy access for calibration

Environmental Considerations

The 631F high temperature transducer is designed to operate at its specified operating temperature. To meet this high operating temperature, you must follow these guidelines:

- DO NOT use a thermal blanket on the 631F transducer
The addition of a thermal blanket will cause the electronics to overheat.
- Provide adequate air circulation
Sufficient air circulation is necessary to prevent heat buildup within the transducer.

Warning



Airflow of at least 50 ft/min is REQUIRED for 150° C units if the ambient temperature is 45° to 50° C (113 to 122°F).

Airflow of at least 150 ft/min is REQUIRED for 200° C units if the ambient temperature is 40° to 50° C (104 to 122°F).

Sensor

The 631F transducer can be installed in any orientation as long as the inlet tube is not facing upwards. However, for best results, it is recommended that the Px port of the unit face downward (as shown in Figure 1) to reduce the chance of contaminants entering the device and degrading its performance. The sensor is zeroed at the factory in the vertical orientation (shown in Figure 1). You should zero the unit again after installation, following the steps in *How To Zero the Type 631F Transducer*, page 37.

If you anticipate vibration, orient the plane of the diaphragm *parallel with* the major oscillating axis. The edge of the diaphragm is indicated by the dashed line in Figure 1.

Note



If vibration causes the unit to be oriented such that the Px port is not facing downward, you must decide the best orientation for optimum performance.

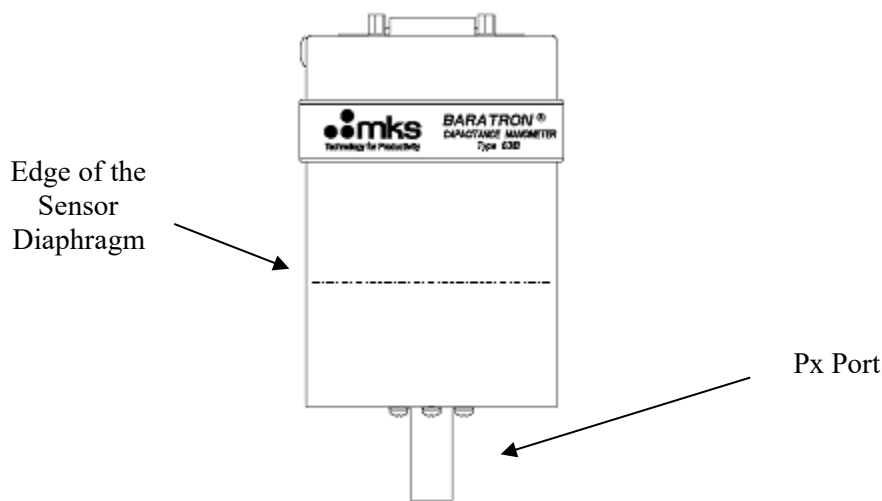

Figure 1: Recommended Orientation of the Type 631F Transducer

Note



Consult the MKS Applications group if your application requires a 1 Torr full scale transducer and you cannot position the 631F transducer vertically.

Piping Considerations and Port Connections

General

- Position a line tap above or to the side of the process line, and position the sensor above the line tap

This allows any liquids which may be present to drain into the process line.

- Install the interconnecting piping so that it slopes *away from* the sensor to the process line
A slope of 1 inch per foot (8 centimeters per meter) is adequate.
- Purge the interconnecting piping (close to the process tap) when needed to prevent sediment buildup

When purging, be sure to isolate the sensor from the interconnecting piping.

Sensor Fittings

The following additional fittings are available for the Type 631F transducer:

- ½" (12.7 mm) tubing
- Swagelok® 8-VCR® female
- NW-16-KF
- 1½" Tri-Clover®
- 2" Tri-Clover

Special Note for ½" (12.7 mm) Tubing

The standard tubing for the 631F transducer is straight ½" (12.7 mm) tubing. The Type 631F transducer has only one pressure port (Px).

To connect the 631F transducer to a Swagelok® Ultra-Torr® compression fitting:

1. Ensure the tubing is clean and free of axial scratches.
2. Insert the tubing through the compression nut and O-ring all the way to the shoulder.
3. Tighten the nut.

This page intentionally left blank.

Chapter Three: Overview

Sensor

The Type 631F transducer contains an *absolute* sensor that is referenced to high vacuum (less than 10^{-7} Torr). This pressure sensor utilizes a single-sided, dual-electrode/AC bridge circuit design. In this design, two capacitance electrodes are deposited upon a ceramic disk in a concentric “bull’s-eye” arrangement. The disk is positioned close to an Inconel® tensioned diaphragm to form two capacitors in an AC bridge circuit. The other side of the diaphragm is exposed to the process gas.

The diaphragm deflects with changing pressure—force per unit area—independent of the composition of the measured gas. This deflection causes a capacitance change between the diaphragm and the adjacent electrode assembly. When pressure is equal on both sides of the diaphragm, the bridge is balanced. As pressure deflects the diaphragm toward the electrode, the center capacitance changes more than the outer capacitance, causing the bridge to become unbalanced and an AC voltage to be generated.

Signal Conditioner

The signal conditioner contains the state-of-the-art, low impedance balanced bridge circuitry, self-compensated for thermal stability with ambient temperature changes. The output is linear with pressure and provides a 0 VDC output at Zero pressure and a 10 VDC output at sensor Full Scale.

Instrument Components and Dimensions

The 631F transducer has two adjustments for zero, a potentiometer and a coarse zero switch. The location of both are the same for the 631F with and without the trip point relay system and are shown in Figure 2: Top View of the Type 631F Transducer Without Optional Relay System and Figure 3: Top View of the Type 631F Transducer With Optional Relay System, pages 30 and 31, respectively.

The top of the 631F transducer without the optional relay system has two LEDs to indicate the status of the sensor heater. At power up, the “At Temp Status” LED will be yellow. Once the sensor temperature reaches the normal operating temperature, this LED will turn green. The “Htr Fail Status” LED is off unless the heater unit fails. Should the heater unit fail, “Htr Fail Status” LED will illuminate red and the “At Temp Status” LED will turn yellow. A “heater alarm relay” will become de-energized and change state providing a remote indication of a heater circuit failure using dedicated pins in the interface connector. Refer to Figure 2: Top View of the Type 631F Transducer Without Optional Relay System, page 30, to identify the location of the “At Temp Status” and “Htr Fail Status” LEDs. Refer to Heater Status LEDs and Heater Alarm Relay, page 40, for a detailed discussion of the operation of the heating system LEDs and relays.

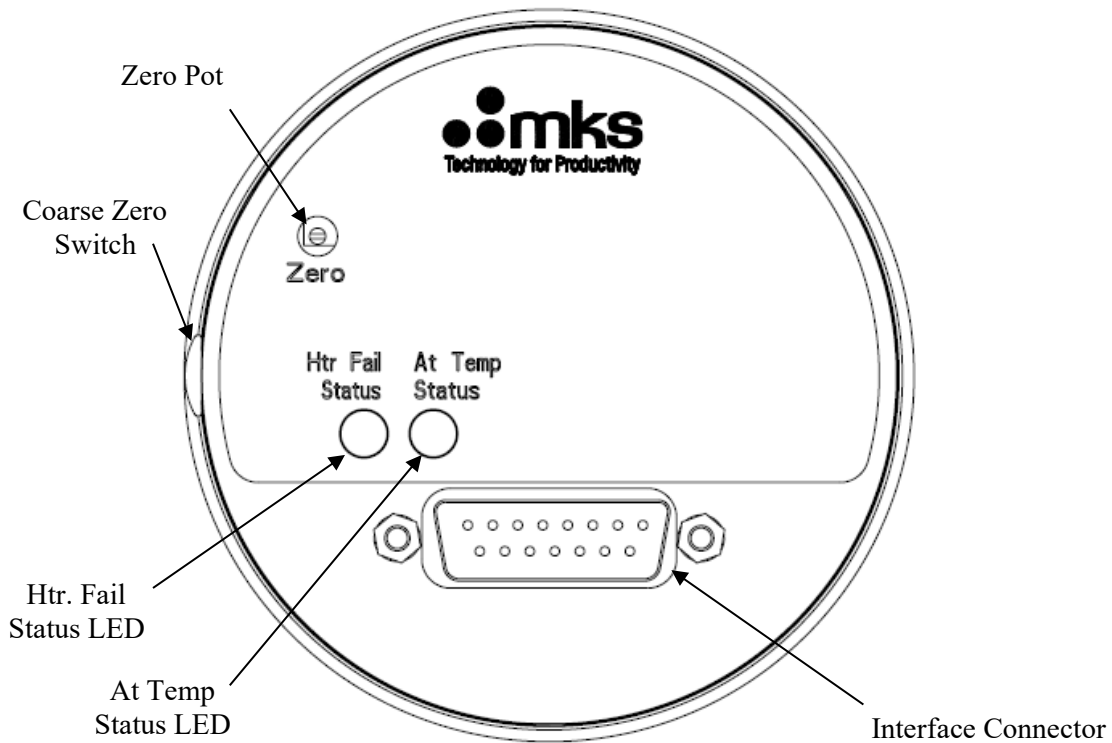

Figure 2: Top View of the Type 631F Transducer Without Optional Relay System

The transducer with the optional trip point relay system has the same functionality as the transducer without the relay system described above. The relay system brings an additional two LEDs, two adjustment POTs and three test plugs to the top of the transducer. (Refer to Figure 3: Top View of the Type 631F Transducer With Optional Relay System, below, showing the

location of the trip point relay system components.) The trip point status LEDs glow green when the corresponding solid-state relay is turned ON and are off when the corresponding solid-state relay is turned OFF, depending on the relationship between the pressure output and the trip point value. (Refer to Chapter Five: Optional Solid-State Relay System, page 43 for a complete description of the relay system.)

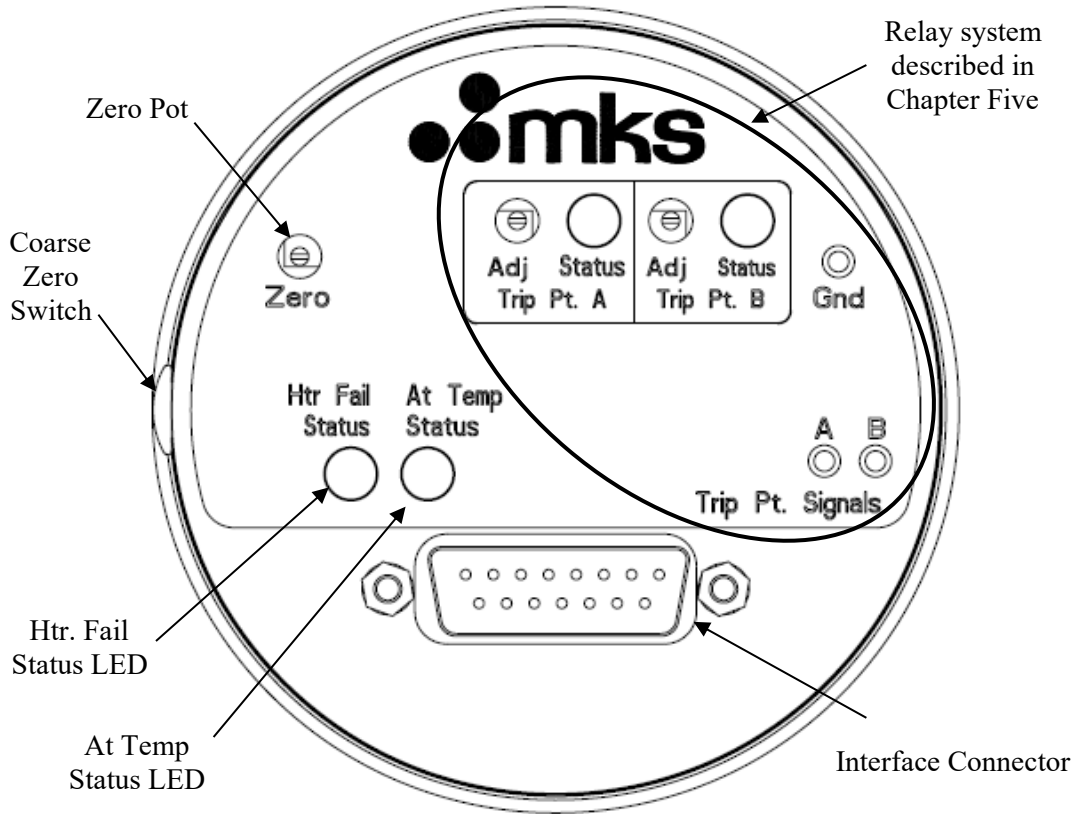

Figure 3: Top View of the Type 631F Transducer With Optional Relay System

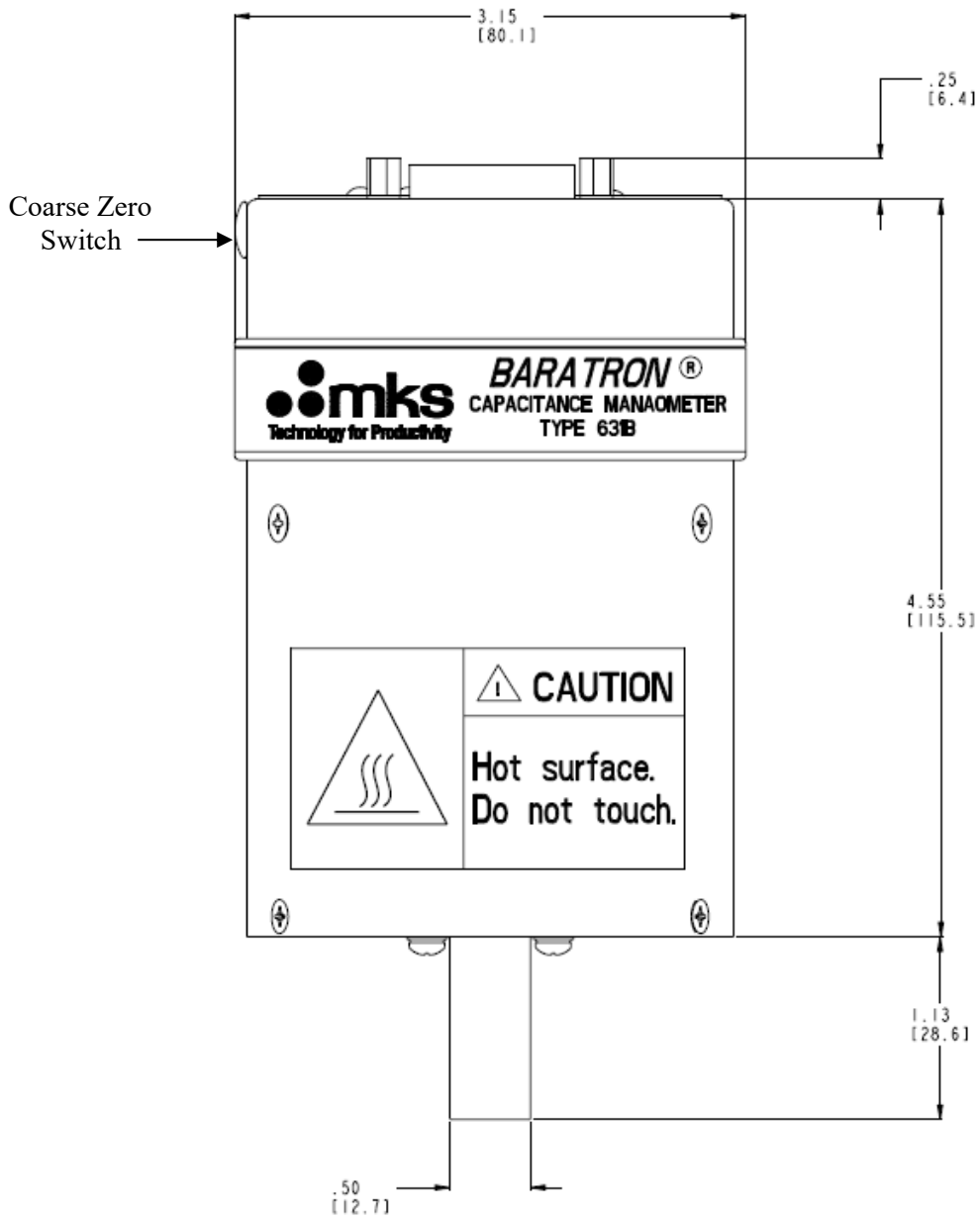

Figure 4: Dimensions of the Type 631F Transducer

Note



All dimensions are nominal and are listed in inches with millimeters referenced in parentheses.

Interface Connector

The Interface connector (J1) is a 15-pin male type D-subminiature connector. Refer to Figure 2: Top View of the Type 631F Transducer, page 30, for the location of the Interface connector for the 631F without the optional relay system. Refer to Figure 3: Top View of the Type 631F Transducer With Optional Relay System, page 31, for the location of the Interface connector for the 631F without the optional relay system. It contains the pins to connect the 631F unit to a power supply or power supply/readout. Table 6 specifies the pinout of the Interface connector.

Note



The state of the relay contacts at pins 13, 14 are for an energized heater alarm relay (normal operation) – refer to Heater Status LEDs and Heater Alarm Relay, page 40 for a description of relay functionality. To use a 631F transducer with any non-MKS power supplies or power supply/readouts, consult the manufacturers' specifications for electrical and power considerations, and Appendix A: Product Specifications, page 49, for electrical requirements of the 631F transducer.

Pinouts of the Interface Connector (J1)		
Pin Number	Assignment Without Relay System	Assignment With Relay System
1	No Connection	Trip Point A Relay N/O
2	Pressure Output	Pressure Output
3	No Connection	Trip Point A Relay Common
4	No Connection	Trip Point A Relay N/C
5	15 V Return	15 V Return
6	-15 VDC	-15 VDC
7	+15 VDC	+15 VDC
8	No Connection	Trip Point B Relay N/O
9	No Connection	Trip Point B Relay Common
10	No Connection	Trip Point B Relay N/C
11	Heater Alarm Relay Common	Heater Alarm Relay Common
12	Pressure Output Return	Pressure Output Return
13	Heater Alarm Relay Open [when energized]	Heater Alarm Relay Open [when energized]
14	Heater Alarm Relay Closed [when energized]	Heater Alarm Relay Closed [when energized]
15	Chassis Ground	Chassis Ground

Table 6: Pinout of the Interface Connector (J1)

Pressure Output

The 631F transducer provides a 0 to 10 VDC output signal at pressures of 100% of its full-scale range and below.

Overpressure Considerations

As with any transducer, the 631F transducer performs valid measurements up to the unit's Full Scale. At pressures of roughly 10% over the Full Scale range, a high (≥ 11 VDC) output signal is produced to warn of invalid readings. This high output signal varies from device to device, and is not linear with further changes in pressure. At pressures somewhat beyond 110% of the Full Scale range, the diaphragm touches the fixed capacitor plate. The capacitor plate serves as a protective overpressure stop to prevent damage to the diaphragm up to 45 psia for an absolute transducer.

Note



The output signal of the 631F above its full-scale measurement range is not linear or repeatable, and should not be used for quantitative measurements or process control. MKS does not guarantee that the product will meet any of its published performance specifications above 110% of its full-scale range.

Labels

Three labels appear on the 631F unit: a wiring diagram label, a "Danger Hot" label, and a serial number label.

Wiring Diagram Label

1 TP A Relay N.O.	6 -15V Supply	11 Htr. Alarm Relay Com.	 BARATRON® CAPACITANCE MANOMETER Type 631B	Protected under one or more of the following: U.S. Patent No. 5625152, 5808206, 5932332, 5811685 or International Patents and Patents pending. Based on model ordered, some pin assignments / signals may not apply.
2 Press. Output	7 +15V Supply	12 Press. Output Return		
3 TP A Relay Com.	8 TP B Relay N.O.	13 Htr. Alarm Relay Open Energized		
4 TP A Relay N.C.	9 TP B Relay Com.	14 Htr. Alarm Relay Closed Energized		
5 Power Return	10 TP B Relay N.C.	15 Chassis Ground		

Figure 5: Wiring Diagram Label

The wiring diagram label shows how to connect a single or dual power supplies to the 631F unit. Refer to Figure 5: Wiring Diagram Label, page 34, for the location of the label on the 631F unit.

"Caution Hot" Label

The “Caution Hot” label appears on lower portion of the unit since the surface may become hot to the touch during operation. Take all necessary precautions to avoid touching the portion of the unit closest to the sensor port during operation. Figure 6: The “Caution Hot” Label, page 35, shows the location of the “Caution Hot” label.



Figure 6: The “Caution Hot” Label

Serial Number Label

The serial number label contains the serial number and specific model code of your unit. It also lists the input power and range individually. The serial number label is affixed to the side of the unit opposite the wiring diagram label.

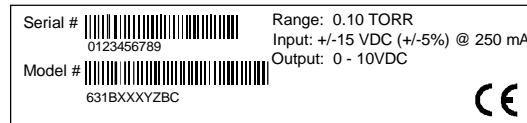

Figure 7: The Serial Number Label

This page intentionally left blank.

Chapter Four: Operation

How To Zero the Type 631F Transducer

MKS pressure transducers are precision measuring instruments, and will require initial and periodic zero adjustments. Prior to initial operation and during periodic maintenance you must check the transducer zero to verify the proper output. The zero can be set (or reset) by adjusting the ZERO potentiometer located on the top of the transducer (refer to How To Adjust the Zero Potentiometer, page 38) or at the front panel of any MKS Power Supply/Readout being used. If the ZERO potentiometer fails to provide sufficient adjustment, the COARSE ZERO switch may be used (refer to *How To Adjust the Coarse Zero Switch*, page 39).

To achieve the full dynamic range specified for the transducer, the zero adjustment *must* be made at a pressure less than the transducer's resolution (refer to Table 7: Highest Pressures Suggested for Proper Zero Adjustment). Low range transducers should be pumped for at least one hour after exposure to air to remove any moisture and to allow the pressure to stabilize. Zeroing a transducer above its stated minimum resolution creates a *zero offset* relative to true absolute pressure. All subsequent readings are then linear and accurate *relative to the offset value*.

Note



If available pressures are not sufficiently low to set the transducer zero, you may use a vacuum leak detector with sufficient vacuum pumping (to achieve proper zeroing pressures). In this case, mount the transducer on the leak detector *in the same plane of orientation as it will be during actual use*.

How To Adjust the Zero Potentiometer

To adjust the ZERO potentiometer:

1. Install the transducer in a system and connect a power supply/readout.
2. Power the transducer and allow it to warm up and stabilize.

Note



Allow 2 hours for units to warm up. Ensure that the transducer is *fully stabilized* before you adjust the zero.

3. Pump the unit down to a pressure below its resolution.

For best results, pump the transducer while it is warming up. Refer to Table 7 for the highest recommended pressure levels for proper zero adjustment.

Zeroing Pressure for 631F Transducer	
Sensor Full Scale (Torr)	Pressure for Zeroing (Torr)
1	$< 0.5 \times 10^{-5}$
2	$< 1.0 \times 10^{-5}$
10	$< 5 \times 10^{-4}$
30	$< 1.5 \times 10^{-3}$
100	$< 5 \times 10^{-3}$
1000	$< 5 \times 10^{-2}$

Table 7: Highest Pressures Suggested for Proper Zero Adjustment

4. Adjust the ZERO potentiometer with a small screwdriver until the readout displays zero (0.000). Typically, the ZERO potentiometer provides ample control under normal conditions. However, if the ZERO potentiometer fails to provide sufficient adjustment, additional zero range capability is available with the COARSE ZERO switch, located on the side of the unit (refer to Figure 2: Top View of the Type 631F Transducer, page 30, or Figure 3: Top View of the Type 631F Transducer With Optional Relay System, page 31, for location of the ZERO potentiometer and coarse zero switch.) Refer to *How To Adjust the Coarse Zero Switch*, page 39, for more information.

How To Adjust the Coarse Zero Switch

Note  Use the COARSE ZERO switch *only* if the ZERO potentiometer fails to provide sufficient adjustment.

To adjust the COARSE ZERO switch:

1. Install the transducer in a system and connect a power supply/readout.
2. Power the transducer and allow it to warm up and stabilize.

Note  Allow 2 hours for units to warm up. Ensure that the transducer is *fully stabilized* and the “At Temp Status” LED is glowing green, before you adjust the zero.

3. Pump the unit down to a pressure below its resolution.
For best results, pump the transducer while it is warming up. Refer to Table 7, page 38, for the highest recommended pressure levels for proper zero adjustment.
4. Center the ZERO potentiometer located at the top of the transducer by adjusting the screw to leave an equal amount of adjustment both clockwise and counterclockwise.
5. Remove the plug that covers the COARSE ZERO switch. Refer Figure 4: Dimensions of the Type 631F Transducer, page 32.
6. Turn the COARSE ZERO switch to a position that produces the output signal closest to 0.000 Volts.
7. Adjust the ZERO potentiometer to bring the output to exactly 0 Volts.
Refer to How To Adjust the Zero Potentiometer, page 38, for more information.
8. Cover the COARSE ZERO switch with the plug removed in step 5.

Heater Status LEDs and Heater Alarm Relay

The 631F transducer is designed to function at its specified operating temperature by maintaining the sensor temperature within a tight range of the operating temperature. There are two status LEDs, “Htr Fail Status” and “At Temp Status,” that provide a visual indication of the heater condition. Since the operating temperature of the sensor is critical, the 631F unit contains a heater alarm relay that monitors the performance of the sensor heater. In addition, the Interface (J1) connector contains the heater alarm relay contact pins. (Refer Table 6: Pinout of the Interface Connector (J1), page 33, for the pinout of the Interface (J1) connector and refer to Table 9, page 41, for a summary of the conditions determining the heater status LEDs and heater alarm relay output.)

When power is applied to the unit, the heater receives full power and the temperature of the sensor rises toward the nominal operating temperature. The heater alarm relay will be energized to indicate that the heater is working. During the warm-up period, the “Htr Fail Status” LED will be off and the “At Temp Status” LED will glow yellow.

When the actual temperature of the sensor is within the LED temperature window, 631F heater is in control and the “At Temp Status” LED will glow green. The heater alarm relay will continue to be energized and the “Htr Fail Status” LED will continue to be off. Note that the LED temperature window is approximately within 8% of the operating temperature, 150°C or 200°C, and is used for a gross indication the sensor is within acceptable limits. The actual operating temperature of the sensor is maintained within a significantly tighter range.

If the heater control circuitry fails in a no-current failure mode, the sensor will begin to cool. At this time, the “Htr Fail Status” LED will glow red and the heater alarm relay will be de-energized. When the sensor temperature falls below the lower limit of the operating temperature LED window, the “At Temp Status” LED will glow yellow.

If the heater control circuit fails in a always-‘On’ mode, the sensor will overheat. The “At Temp Status” LED will glow yellow when the sensor temperature reaches the upper limit of the LED temperature window, the “Htr Fail Status” LED will continue to be off and the heater alarm relay will continue to be energized.

Over-Temperature Protection

The heater implements two temperature sensors, one dedicated to the heater control circuit and one dedicated to the over-temperature protection. The over-temperature protection limit is used as one layer of protection by the heater alarm circuit, refer to Table 8: Over-Temperature Cutoff Value for the over-temperature value for each of the operating temperatures. If the transducer temperature reaches the over temperature cutoff, the “Htr Fail Status” LED will glow red, the heater alarm relay becomes de-energized and the “At Temp Status” LED will glow yellow. Note that once the temperature drops below the overtemperature cutoff, the heater power will be activated, the heater alarm relay energized, the “At Temp Status” LED will continue to glow yellow and the “Htr Fail Status” LED will turn off.

Operating Temperature (°C)	Over-Temperature Value (°C)
-------------------------------	--------------------------------

150	185
200	230

Table 8: Over-Temperature Cutoff Value

Conditions Determining Status LEDs and Relay Output	At Temp Status LED	Htr Fail Status LED	State of Heater Alarm Relay Contacts
1. Power ON 2. Temp below lower limit of LED temperature window 3. Heater current ON	Yellow	Off	Energized Pin 13: Open Pin 14: Closed
1. Power ON 2. Temp below lower limit of LED temperature window 3. Heater current OFF	Yellow	Red	De-energized Pin 13: Closed Pin 14: Open
1. Power ON 2. Temp within LED temperature window 3. Heater current ON or OFF	Green	Off	Energized Pin 13: Open Pin 14: Closed
1. Power ON 2. Temp above upper limit of LED temperature window 3. Temp below overtemperature cutoff 4. Heater current ON	Yellow	Off	Energized Pin 13: Open Pin 14: Closed
1. Power ON 2. Temp above upper limit of LED temperature window 3. Temp below overtemperature cutoff 4. Heater current OFF	Yellow	Red	De-energized Pin 13: Closed Pin 14: Open
1. Power ON 2. Temp above overtemperature 3. Heater current ON or OFF	Yellow	Red	De-energized Pin 13: Closed Pin 14: Open
1. Power OFF	Off	Off	De-energized Pin 13: Closed Pin 14: Open

Table 9: Conditions and resulting status LEDs and heater alarm relay output.

This page intentionally left blank.

Chapter Five: Optional Solid-State Relay System

General Information

The 631F transducer provides the option for two (2) internally mounted trip point relays with user adjustable pressure conditions that will turn ON/OFF each solid state relay. The trip point direction – whether the relay turns ON above or below the selected pressure condition – is chosen using the appropriate model code when purchasing the 631F transducer (refer to Appendix B: Model Code Explanation, page 51). A visual indication of the status of each trip point relay is provided by a dedicated LED that illuminates when the trip point relay is turned ON. The relay gets turned OFF and the LED turns off when the pressure returns to the selected trip point value plus hysteresis (refer to Trip Point Direction, page 44 for a description of how hysteresis affects the relay switching).

The interface connector houses the contact pins of both trip point relays to equip the user with remote indication of the relay status. The three pins of each relay produce an open/closed output; for example, if Trip Point A is turned ON, pins 3 & 4 will be an open circuit. Refer to Table 6: Pinout of the Interface Connector (J1), page 33, for the pinout of the Interface (J1) Connector.

Trip Point Parameters

Trip Point Values

The trip point value is the pressure condition that each relay will get turned ON. The trip point value of each relay can be adjusted individually using the trip point adjustment POTs. These POTs are located on the top of the 631F unit, as shown on Figure 8, page 44, and labeled as “Adj” above the corresponding “Trip Pt A” and “Trip Pt B” label. The trip point value can be monitored by measuring the voltage between the trip point signal of interest and the ground (labeled as “Trip Pt. Signals” and “Gnd”). A pair of 0.080 inch test point jacks must be used in order to gain access to the trip point voltage signals. The trip point signal voltage ranges from 0 to 10 V, which corresponds to the pressure range of the unit from zero to full scale.

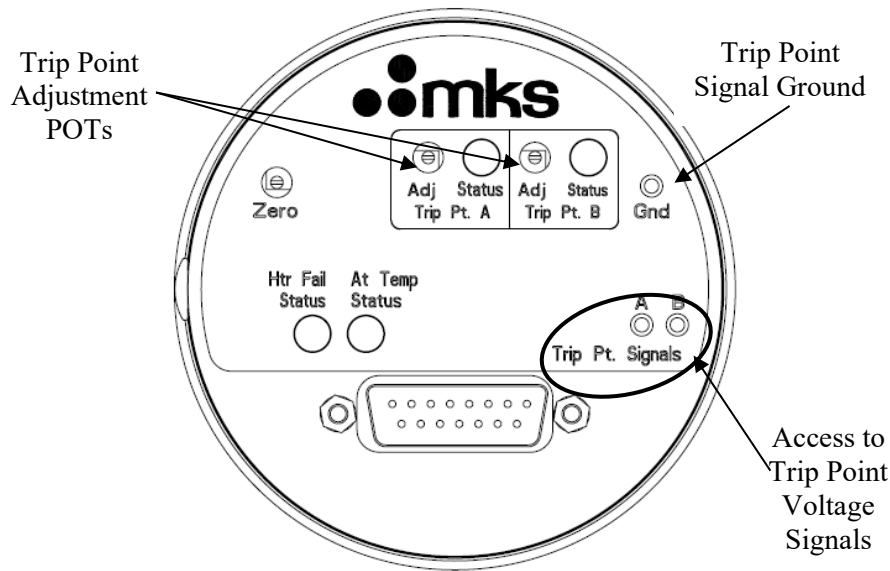

Figure 8: Location of the Trip Point Adjustment Pots and Trip Point Signal Output

Note



The trip point adjustment voltage ranges from 0 to 10 Volts, corresponding to the pressure range of the unit zero to full scale.

Trip Point Direction

The trip point direction defines the direction of pressure change that will turn ON the solid-state relay’s trip points. The direction of each relay is preset during manufacturing of the relay (A) when the pressure rises above the trip point value, or (B) when the pressure drops below the trip point value. Each relay functions independently, so each of the two relays can be set to trip in the same or in opposite directions. The customer can choose the direction of each trip point relay using the appropriate model code, see Appendix B: Model Code Explanation, page 51.

If the preset direction for Trip Point A is “above”; the trip point is turned ON as the pressure rises *above* the specified trip point value. The trip point is not turned OFF until the pressure falls below the value defined by the hysteresis, as shown in Figure 9, page 45. Figure 9 also depicts the relay being turned ON when the initial pressure condition applied to the unit is above the trip point value. The trip point hysteresis is preset as 0.3% of FS (0.030 Volts) and its purpose to prevent undesired bouncing in the solid state relay.

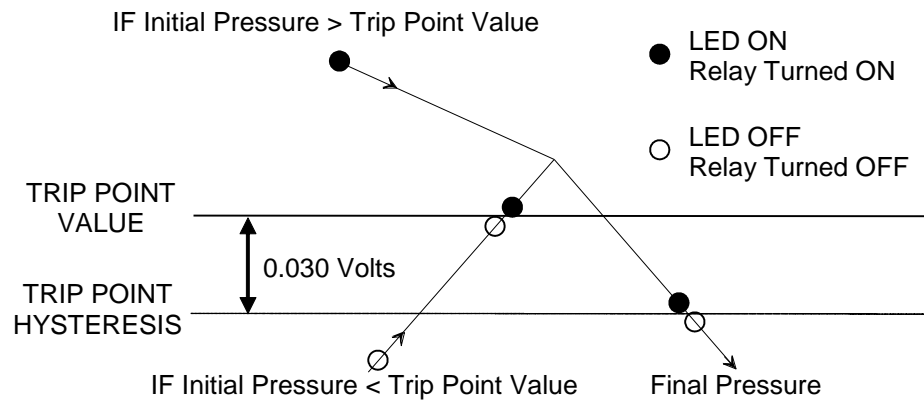

Figure 9: LED and Relay State When Trip Point Direction Set Above Trip Point Value

If the preset direction for Trip Point B is “below”; the trip point is turned ON as the pressure falls *below* the specified trip point level. The trip point is not turned OFF until the pressure rises above the value defined by the hysteresis, as shown in Figure 10. Figure 10 also depicts the relay being turned ON when the initial pressure condition applied to the unit is below the trip point value.

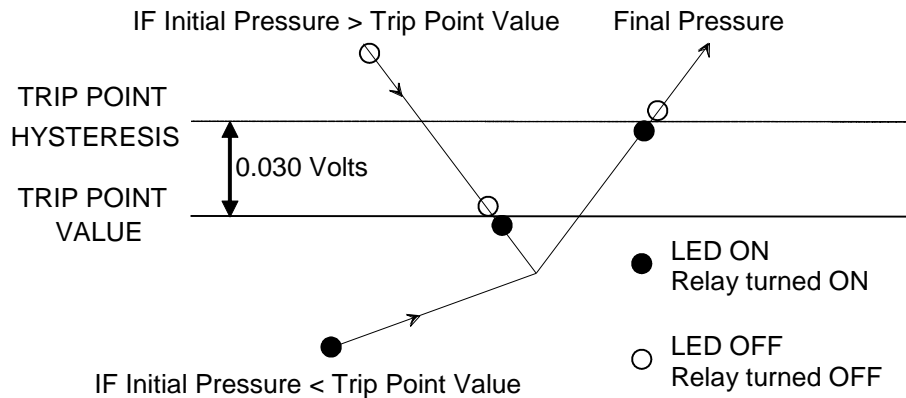

Figure 10: LED and Relay State When Trip Point Direction Set Below Trip Point Value

Note that regardless of trip point direction the time response of the 631F transducer will have a minor affect of the time between (1) a change in the pressure condition necessary to cause a change in the relay state and (2) the relay actually changing state. The time response is specified in Appendix A: Product Specifications, page 49.

This page intentionally left blank.

Chapter Six: Maintenance and Troubleshooting

General Maintenance

For best accuracy and repeatability, MKS recommends that you:

- Zero the unit regularly
Follow the procedure described in How To Zero the Type 631F Transducer, page 37, on a regular basis.
- Schedule re-calibration annually
Follow an annual recalibration schedule, if no other time interval has been specifically established.
- Periodically check for wear on the cables and inspect the enclosure for visible signs of damage

Troubleshooting

High, Low, or Erratic Output, or No Output at All

Check the Interconnecting Piping

- Be sure there are no leaks or blockage in the interconnecting piping
- Look for sediment in the sensor process connection(s)

Remove the sediment by purging the connection(s) with a solvent appropriate for your process.

Caution



Damage may occur to the sensor if the sediment is removed with a harsh solvent, or by scraping. Therefore:

- **Do not scrape the inside of the process connection(s).**
 - **Only clean the process connection(s) with solvent appropriate for your process.**
-

Check the Wiring

- Ensure the voltage to the transducer is ± 15 VDC ($\pm 5\%$) @ 1.0 Amps
- Verify that the total current being drawn by the manometer is within the specifications of the power supply
- Check the signal terminals for the correct polarity
- Measure the loop impedance
- Look for shorts, multiple grounds, and defective wire insulation

If the solutions presented in this chapter fail to resolve the problem, return the transducer to MKS for servicing. When returning the instrument to MKS, please obtain an RMA Number (Return Material Authorization Number) from the MKS Calibration and Service Center before shipping. The RMA Number expedites handling and ensures proper servicing of your instrument.

Refer to the inside of the back cover of this instruction manual for a complete list of MKS Calibration and Service centers.

Warning



All returns to MKS Instruments must be free of harmful, corrosive, radioactive, or toxic materials.

Appendix A: Product Specifications

Physical Specifications

Dimensions ³	3.15" diameter, 4.55" length, maximum (8.00 cm diameter, 11.55 cm length)
Fittings	½" (12.7 mm) tubulation, Swagelok 8-VCR (female), NW-16-KF, 1½" Tri-Clover, 2" Tri-Clover
Full Scale Ranges	1, 2, 10, 30, 100, 1000 mmHg (Torr) For other ranges, consult factory
Heater Unit Relay Initial State (during operation) Contact Rating	Energized 1 Amp @ 24 VDC
Input Required Dual power supply	±15 VDC ±5% @ 1.0 Amp (max.)
Material Exposed to Gases (P _X port)	Inconel [®] and Incoloy [®] nickel alloys. Some fitting options may be made from 300-series stainless steel.
Number of Decades Covered	4
Optional Trip Point Relay Setting Output	0 to 10 VDC (corresponding to 0 to 100% F.S.) for each trip point
Optional Trip Point Relay Specifications	Two (2) Form C solid-state relays (SPDT contact), 200mA max. @ 30 VDC, UL1577 approval. Relay Contact ON resistance: 15 Ohms max, CSA Certification 093751.
Output (linear with pressure)	0 to 10 VDC (into ≥ 10K ohm load)
Overpressure Limit	120% of F.S. or 45 psia, whichever is greater
Sensor Temperature	150° C (302° F), 200° C (392° F)
Type of Measurement	Absolute pressure
Volume (P _X side)	7.33 cc (0.447 cu. in.)
Weight	1.16 lbs (0.524 kg)

³ Dimensions do not include the external connector and tubulation.

Performance Specifications

Accuracy ⁴ 150° C; 200° C	± 0.5% of Reading	
RoHS (Restriction of Hazardous Substances) Compliance	Compliant with Directive 2002/95/EC	
CE Compliance Electromagnetic Compatibility	Compliant with EMC Directive 2004/108/EC	
Temperature Coefficients Zero (≥ 10 Torr ranges) Zero (< 10 Torr) Span	<i>150° C Units</i> 0.004% F.S./°C 0.008% F.S./°C 0.02% of Reading/°C	<i>200° C Units</i> 0.008% F.S./°C 0.016% F.S./°C 0.02% of Reading/°C
Time Response	<50 milliseconds	

Environmental Specifications

Ambient Operating Temperature Range 150° C Units	10° to 50° C* (50° to 122° F) * Minimum 50 ft/min air flow is required if the ambient temperature is between 45° to 50° C (113° to 122° F)
200° C Units	10° to 50° C** (50° to 122° F) ** Minimum 150 ft/min air flow is required if the ambient temperature is between 40° to 50° C (104° to 122° F)
Storage Humidity Range	25 to 95% Relative Humidity, non-condensing
Storage Temperature Range	-20 to +80° C (-4 to 176° F)

Due to continuing research and development activities, these product specifications are subject to change without notice.

⁴ Includes non-linearity, hysteresis, and non-repeatability.

Appendix B: Model Code Explanation

Model Code

The options of your transducer are identified in the model code when you order the unit.

The model code is identified as follows:

631FWWXYZTUV

where:

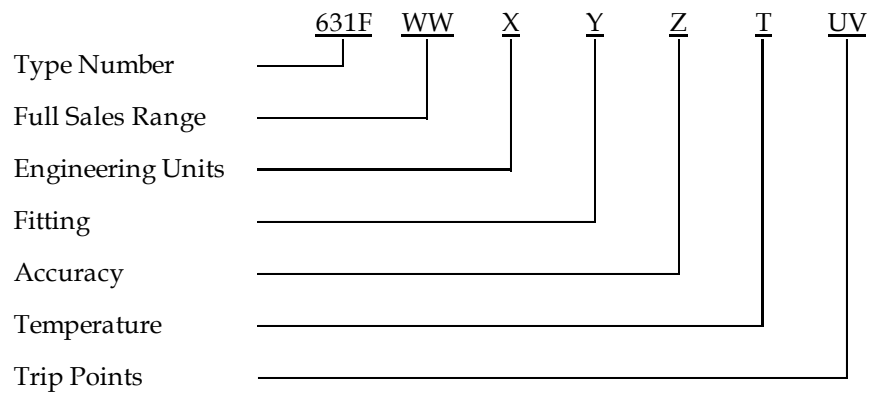

Type Number (631F)

This designates the model number of the instrument.

Full Scale Range (WW)

The full scale range is indicated by a two digit code.

	Ordering Code
1	01
2	02
10	11
30	31
100	12
1000	13

Engineering Units (X)

Your choice of engineering units is designated by a single letter code.

	Ordering Code
Torr / mm Hg	T

KiloPascal	K
Pascal	L
Mbar	M

Fittings (Y)

Your fitting choice is designated by a single letter code.

	Ordering Code
½” diameter tube	A
Swagelok 8-VCR, female	B
NW-16-KF	D
1½” Tri-Clover	M
2” Tri-Clover	N

Accuracy (Z)

The standard accuracy ($\pm 0.5\%$ of Reading) is specified by a letter F in this field.

Temperature (T)

The operating temperature of the transducer is specified by a single letter.

	Ordering Code
150° C	H
200° C	P

Trip Points (UV)

The optional relay system is specified by a two letter code. When ordering without the relay system, this portion of the model code is omitted.

The Trip Point Direction		Trip Point Value		Ordering Code
Trip Point A	Trip Point B	Trip Point A	Trip Point B	
Above	Above	5 Volts	5 Volts	AA
Above	Below	5 Volts	5 Volts	AB
Below	Below	5 Volts	5 Volts	BB
Below	Above	5 Volts	5 Volts	BA
Above	Below	5 Volts	9.5 Volts	02
Below	Below	5 Volts	9.5 Volts	03

This page intentionally left blank.

Index

A

Accuracy, 17, 50, 52
Air flow, 24, 25, 50
Alarm, heater, 40

C

Cables, 17, 22, 23
CE compliance, 50
Connectors, 30, 31, 33
Customer support, 18

D

Dimensions, 32, 49

E

Environmental, 24, 25, 50

F

Fittings, 27, 49, 52
Full scale range, 17, 49, 51

G

Grounding, 23

H

Heater fail relay, 40, 41, 49
Humidity
 storage, 24, 50

I

Input power, 17, 23, 48, 49
Interface cables, 17, 22

L

Labels, 34, 35
 hot, 35
 serial number, 35
 wiring diagram, 34

M

Maintenance, 47
Manual organization, 18
Model code, 51
Mounting, 25, 26

O

Output signal, 17, 29, 34, 49
Overpressure, 17, 23, 34, 49
Overtemperature, 40, 41

P

Pinout, connector, 33, 43
Piping considerations, 27
Port connections, 26, 27
Power supply
 current rating, 23, 48
 wiring, 23, 34
Power supply, wiring, 34

R

Relay
 heater fail, 17, 40
 trip point, 17, 29
Returning the product, 18, 21

S

Sensor, 17, 26, 29

Sensor fittings, 27

Setup, 25, 26

Signal conditioner, 17, 29

Standard sensor fittings, 27

T

Temperature

coefficients, 50

operating, ambient, 24, 25, 50

operating, sensor, 17, 40, 49, 52

storage, 24, 50

Time response, 50

Trip point relay system, 17, 29, 43

direction, 43, 44, 53

hysteresis, 45

value, 43, 53

Troubleshooting, 48

V

Ventilation, 24, 25, 50

Vibration, 23, 26

W

Warm up, 17, 23

Z

Zero adjustment

coarse zero switch, 37, 39

zero pot, 37, 38