

## RAPISCAN 620DV

### Checkpoint Screening Screening



*baggage & parcel*

*inspection  
technology*



Shown with optional Operator Pedestal  
Tunnel Opening (width x height):  
25.2 x 16.9 in (640 x 430)

Checkpoint Screening System approved as an Advanced Technology (AT) system by U.S. TSA, Liquid Explosive Detection System (LEDS) by E.U and certified by CAAC.

The Rapiscan 620DV is an advanced checkpoint screening solution, designed for aviation and high security applications. It uses innovative dual view technology to generate a horizontal and vertical view of the object under inspection.

Rapiscan 620DV has been approved and included on the qualified list applicable to the U.S. TSA Advanced Technology (AT) checkpoint program as well as the qualified list applicable to E.U. ECAC Liquid Explosive Detection System (LEDS) Common Evaluation Process (CEP) for security equipment.

Rapiscan 620DV provides unsurpassed image quality, regulatory approved automatic detection of solid explosive software (Target™) and Automatic Liquid Explosive Identification Software (aLEXis™) with the largest global approvals and certifications.

#### Automatic Detection of Explosives

Target™ automatically detects a wide range of solid and liquid explosives in real time during the scanning process by visibly highlighting a potential threat on the X-ray image.

#### Automatic Detection of Narcotics

NARCSan™ automatically detects a wide range of narcotics in real time during the scanning process by visibly highlighting a potential threat on the X-ray image.

#### Meeting Today's Most Stringent Global Requirements

The Rapiscan 620DV meets the most rigorous detection and image quality requirements as set by the U.S. Transportation Security Administration (TSA), U.K. Department of Transport (DfT), European Union, French civil aviation authority (STAC), Civil Aviation Administration of China (CAAC), and Transport Canada (TC).

#### Greatest Number of Operator-Assist Tools Enables Highest Throughput

With over 13 image processing tools and multiple automatic detection functions, the feature rich software helps the operator easily and accurately detect contraband for the highest throughput and least operator fatigue.

#### Regulatory Compliance

Rapiscan 620DV image quality performance is in compliance with regulation (EC) No. 300/2008. In addition, Rapiscan 620DV Threat Image Projection (TIP) is in compliance with regulation (EU) No. 185/2010.

#### Dual View Advanced Technology

Government regulators such as U.S. Transportation Security Administration (TSA) require dual view technology for screening objects. The 620DV is able to produce two (2) separate simultaneous images from perpendicular orientations providing a more complete image, reducing the need for repositioning and rescanning and enabling rapid, accurate and comprehensive threat detection.

#### Standard Features

- Multi Energy Imaging (4 Color)
- View Previous/Next Bag
- Manual Image Archive
- Configurable Image Processing Keys
- Baggage Counter
- Date / Time Display
- Search Indicator
- UPS (Uninterrupted Power Supply)
- Flat Panel Monitor

#### Standard Image Processing Functions

- Crystal Clear™
- Black and White
- Organic / Inorganic Stripping
- Inverse Video
- High Penetration
- Pseudo Color
- Variable Edge Enhancement
- Variable Color Stripping
- Variable Gamma
- Variable Density
- Dynamic Continuous Zoom & Panning
- Fixed Zoom (64x)

# RAPISCAN 620DV

## Physical Specifications

Dimensions:	Length: 113.4 in. (2880 mm) Width: 56.3 in. (1,430 mm) Height: 55.8 in. (1,418 mm)
Tunnel Size:	25.2 (W) x 16.9 in. (H) (640 mm x 430 mm)
Conveyor Speed:	43.34 ft./min (0.22 m/sec)
Conveyor Load:	364 lbs (165 Kg) evenly distributed
Conveyor Height:	32.5 in. (826 mm)
Approx Weight:	Net: 2205 lbs (1000 Kg)
System Power:	115/230 VAC $\pm$ 10%, 60/50Hz

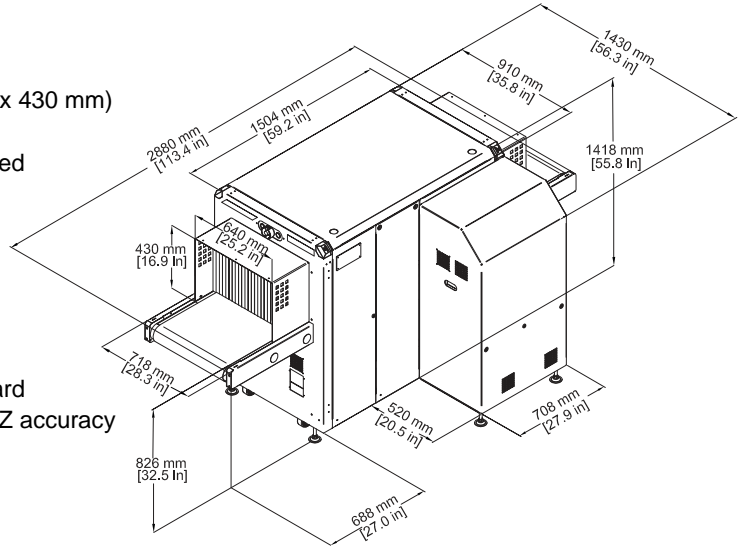

## X-Ray Generator and Image Performance\*

Steel Penetration:	35 mm typical, 40 mm standard
Wire Resolution:	38 AWG typical, 40 AWG standard
Material Separation:	Low Z, Medium Z, High Z to 0.5 Z accuracy
Generator Cooling:	Sealed oil bath with forced air
Anode Voltage:	Operating at 160KV
Tube Current:	1.0 mA
Orientation:	Vertical and Horizontal

## Operating Environment

Storage Temperature:	-4° to 122°F (-20° to 50°C)
Operating Temperature:	32° to 104°F (0° to 40°C)
Relative Humidity:	5 to 95% non-condensing

## Health and Safety

Rapiscan Systems' cabinet X-ray products comply with all applicable U.S. FDA and equivalent international regulatory agency requirements, contained in the cabinet X-ray radiation safety performance standard [21 CFR 1020.40] and the general performance standard [21 CFR Part 1010] as well as IEC standard 61010-2-091.

Rapiscan baggage and parcel inspection systems radiation emission leakages are well below the required regulatory limits with less than 1 $\mu$ Sv/hr at 10 cm from all surfaces of cabinet X-ray.

## Options and Accessories

- \*\*aLEXis™ (Automatic detection of Liquids, Aerosols and Gels (LAGs) explosives)
- Target™ / Interactive Target™ (Automatic detection of solid explosives)
- NARCSan™ (Automatic detection of narcotics)
- Density Threshold Alert (DTA)
- Threat Image Projection (TIP)
- Threat Image Projection Network (TIPNet)
- NETView™ (Remote network image archive review)
- NEXLink™ (Advanced network X-ray management automation and link system)
- Multi-System Alarm Resolution Network Display Station (NDS)
- Automatic Image Archiving
- Enhanced Image Archiving
- Operator Training Program (OTP)
- Manual Scan
- Operator Pedestal
- Foot-mat
- Optical Operator Presence Sensor
- SmartCard Login
- Power Conditioner
- Conveyor Accessories
- Remote Workstation
- Universal Printer Support

\*Stated performance as measured by Rapiscan Imaging Validation Test Kit. Stated Dual View performance as measured in primary view.

\*\*Please request from your local sales representative for the kit specific part numbers when ordering aLEXis™.

