

MANUAL- PM12

PERSONAL MONITOR

Thermo Fisher Scientific

PM12

30th December 2011



© Thermo Fisher Scientific 2011

ALL RIGHTS RESERVED.

REPRODUCTION IN WHOLE OR IN PART OF ALL MATERIAL IN THIS PUBLICATION, INCLUDING DRAWINGS AND DIAGRAMS, IS FORBIDDEN.

THIS INSTRUCTION MANUAL IS CONFIDENTIAL TO THERMO FISHER SCIENTIFIC AND IS SUPPLIED FOR USE ONLY IN CONNECTION WITH THE OPERATION AND/OR MAINTENANCE OF THE EQUIPMENT TO WHICH IT RELATES, AS SUPPLIED BY THERMO FISHER SCIENTIFIC. THE CONTENTS MUST NOT BE USED FOR OTHER PURPOSES, NOR DISCLOSED TO ANY THIRD PARTY, WITHOUT THE PRIOR WRITTEN CONSENT OF THERMO FISHER SCIENTIFIC.

This manual was produced using *ComponentOne Doc-To-Help*[™].

NOTICE

PM12

WARRANTY AND LIABILITY

THERMO FISHER SCIENTIFIC reserves the right to make changes to this manual and to the equipment described herein without notice. Considerable effort has been made to insure that this manual is free of inaccuracies and omissions. However, THERMO FISHER SCIENTIFIC, makes no warranty of any kind including, but not limited to, any implied warranties of merchantability and fitness for a particular purpose with regard to this manual. THERMO FISHER SCIENTIFIC, assumes no responsibility for, or liability for, errors contained in this manual or for incidental, special, or consequential damages arising out of the furnishing of this manual, or the use of this manual in operating the equipment, or in connection with the performance of the equipment when so operated.

IMPORTANT NOTICE

All units produced after the 1st January 1996 must by law conform to the rules and regulations governing Electro-magnetic compatibility (EMC). In order to meet the requirements and CE mark the units described in this manual, any maintenance carried out must ensure the correct re-assembly of all parts, especially the earth straps. Furthermore, particular attention should be made to the correct mounting of the mains filter.

WARNING

Personnel may trigger an alarm on a PM12, who have recently been subject to radiotherapy treatments that involve the injection or ingestion of radioactive isotopes. The monitor is not able to distinguish these isotopes from those generated via an on-site process. However the monitor does have the ability to indicate the presence of low energy photon emitting isotopes, which are typical of radiotherapy treatments.

The PM12 monitor should be primarily used for monitoring personnel. Other objects and articles should be monitored with a monitor that is designed for their monitoring, such as a SAM12.

However if articles are passed through the monitor, operational procedures should contain warnings regarding inappropriate articles.

These items may include:

- Articles containing liquids
- Articles with significant shielding
- Articles containing large magnets
- Articles with known radioactive content

Articles containing liquids may have different release criteria. Articles of large weight or significant shielding may require different procedures requiring Health Physics intervention. Articles with a magnetic pull of more than four pounds may influence the accuracy of the monitor.

The PM12 weighs between 0.75 and 1 tonne. The monitor should only be installed and used on a suitably robust and stable base. The monitor should never be moved with the lead installed.



WARNING AGAINST IMPROPER USE

The protection provided by this equipment may be impaired if used in a manner not specified by the manufacturer. The user must adhere to all the safety precautions noted overleaf and to individual warnings contained within this manual.

WARNING SYMBOLS:

The following is an explanation of the warning symbols seen on the PM12. Please read this information before using and/or maintaining this equipment.

As seen on the top of the PM12 frame and FHT681 covers.

	CAUTION: Isolate the mains supply and wait one minute before removing this cover.
	CAUTION: Isolate HV supply to the printed circuit board before removing cover. With power connected and unit switched on, a max. voltage of +1500V DC with a maximum short circuit power of 825 milliwatts is present.
	CAUTION: Risk of electric shock.

WEEE COMPLIANCE:

This product is required to comply with the European Union's Waste Electrical & Electronic Equipment (WEEE) Directive 2002/96/EC. It is marked with the following symbol:



Thermo Fisher Scientific has contracted with one or more recycling/disposal companies in each EU Member State, and this product should be disposed of or recycled through them. Further information on Thermo Fisher's compliance with these Directives, the recyclers in your country, and information on Thermo Fisher products which may assist the detection of substances subject to the RoHS Directive are available at www.thermofisher.com/WEEERoHS

Contents

	Manual Revision History	1-13
	Foreword.....	xv
Chapter 1	Introduction.....	1-1
	Personnel Monitor.....	1-1
	Features.....	1-2
Chapter 2	Description	2-1
	Main Frame Type 11705121 (11705302)	2-1
	Electronics Chassis Type 11705181	2-2
	Main Controller Board Type 5691A.....	2-2
	IO Expansion Board Type 5694A	2-3
	X-Channel GPIO Board Type 5707A.....	2-3
	Battery Controller Board Type 5660A.....	2-3
	DC-DC Converter Board Type 5675A	2-4
	Scintillation HV and Amplifier Type 42543-0223 used in Assembly 11705186	2-4
	Annunciators Type 11705182A/B	2-4
	Sensor Interconnect Type 5697A	2-5
	Scintillation Detector Type 5678A	2-5
	Power Door Option	2-5
Chapter 3	Specification	3-1
	Operational Parameters	3-1
	Software Options.....	3-1
	Default Messages.....	3-1
	Background Capability.....	3-2
	Detectors	3-3
	Eight Detectors	3-3
	Detector HV settings.....	3-3
	Energy Window	3-3
	Control	3-3
	Displays	3-4
	LCD	3-4
	Lamps	3-4
	Charging LED.....	3-4
	Audible Indications	3-4
	Network Communications.....	3-6
	USB Ports.....	3-6
	Power Requirements.....	3-6
	Battery Backup [†]	3-6
	Dimensions (approximate).....	3-7
	Overall Dimensions (excluding LCD but including foot-plate).....	3-7
	Dimensions of Internal Passage (all Versions)	3-7
	Weight - with 0.5" (12.5 mm) of lead shielding	3-7
	Weight - with 1" (25 mm) of lead shielding	3-7
	Environmental.....	3-7
	Temperature and Humidity	3-7
	Magnetic Shielding	3-8
	IP rating	3-8

	Environmental restrictions	3-8
Chapter 4	Unpacking and Installation	4-1
	Unpacking.....	4-1
	Mechanical Installation	4-3
	Installation of Detectors and Lead Shielding	4-3
	Operational Setup	4-6
	Portal Location.....	4-6
	Barriers	4-6
	Mode of Operation.....	4-7
	Electrical Installation.....	4-7
	Battery State.....	4-7
	Electrical Installation	4-8
	Printer Installation.....	4-10
	Notes on Orientation and Positioning.....	4-11
Chapter 5	Operating Instructions	5-1
	Operational States.....	5-1
	Selecting Detectors	5-5
	Setup Menu	5-8
	Interfaces.....	5-21
	Diagnostics Menu	5-28
	Calibration Menu	5-35
	Data Menu	5-48
	System Menu	5-65
	User Mode.....	5-68
	Switch On.....	5-72
	Monitoring.....	5-77
	Entering the Portal	5-77
	Commence Monitoring	5-80
	Monitoring Result	5-87
	Exiting the Portal	5-93
	Out Of Service	5-94
	Battery/Mains Supply Indicator	5-97
	Switch Off.....	5-97
Chapter 6	Technical Description - Physics	6-1
	Performance Characteristics.....	6-1
	Introduction.....	6-1
	Spatial Response.....	6-2
	Explanation of the Operational Calculations	6-2
	Introduction.....	6-2
	Description of Parameters Used in Calculations.....	6-3
	Background Update	6-5
	Changing Background	6-6
	Calculation of the Monitoring Time (T_{cal})	6-7
	Minimum Detectable Activity (MDA) and High Background Criterion	6-8
	Changing Conditions	6-8
	Contamination Alarm	6-9
	Calculation of Activity and Uncertainty	6-9
	Quickscan	6-10
	Quick Background	6-10
	Cobalt 60 Window Monitoring.....	6-10
	Residual Contamination Level.....	6-11
	Automatic Calculation of Calibration Monitoring Time.....	6-11
	Isotope gamma efficiencies	6-12
	PM12 – Standard with aluminium door panels.....	6-12
	Probability – Sigma and %	6-12

Chapter 7	Technical Description - Circuitry	7-1
	Introduction	7-1
	Electronic Chassis 11705181	7-2
	Controller Board Pair - Types 5691A and 5694A	7-2
	ETX Processor	7-2
	Summary of 5691A Functions	7-3
	I/O Expansion Card 5694A	7-4
	Expansion Card Inputs and Outputs	7-4
	PM12C GPIO Controller Card 5707A	7-5
	Battery Controller Board Type 5660A	7-6
	Keyswitch Operation	7-6
	Annunciator Assembly 11705182A/B	7-7
	Sensor Assembly 11705235/A & B and Connect Card 5697A	7-7
	FHT681 Scintillation HV & Amplifier	7-7
	HV & Amplifier Connections	7-7
	Modules 11705186	7-8
	Mains Power Module (Assembly 11705184)	7-8
	LCD Display and Controller I/F & Backlight Inverter Module (Assembly 11705210)	7-9
	General Electromagnetic Compatibility (EMC) Considerations	7-9
Chapter 8	Routine Checks	8-1
	Mechanical Checks	8-1
	PM12 Mounting Arrangement	8-1
	Other Mechanical Checks	8-1
	Electrical Checks	8-1
	Battery Charge state	8-1
	Display Checks	8-2
	EMC & Safety Earthing Checks	8-2
	Periodic Source Checks	8-2
	Regular Source checks	8-3
	Cleaning Instructions	8-3
Chapter 9	Setting Up Procedure	9-1
	Initial Setting Up for Use	9-1
	General	9-1
	Initialisation	9-1
	Setting Passwords	9-1
	Setting the Operational Parameters	9-2
	Selection of Detector Operating Parameters	9-3
	Detector HV Selection	9-3
	Derivation of the Optimum Operating Voltage	9-3
	Variance Testing	9-7
Chapter 10	Calibration Procedure	10-1
	Calibration Validity	10-1
	Equipment Required	10-1
	Preparation for Calibration	10-2
	Calibration	10-2
	Calibration for Other Nuclides	10-3
	Calibration mixes	10-3
	Troubleshooting (Calibration)	10-4
	If Background Values Vary by More Than 30%	10-4
	If Nuclide Count-Rate Outside Required Value	10-4
Chapter 11	Maintenance and Trouble Shooting	11-1
	Fault Messages	11-1

Power-up Screens	11-1
Self Test Screens.....	11-1
Device Error Messages	11-2
Operational Self Tests.....	11-2
Servicing of the Electronic Assemblies.....	11-3
Access to Electronic Chassis	11-3
Removal of the Electronics Chassis from the Corner Frame	11-4
Removal and Replacement of the Power Supply	11-5
<i>Mains Inlet/Filter & Isolator</i>	11-6
Battery - Removal and Replacement	11-6
Hard Disk Drive Removal and Replacement	11-7
Battery Controller Board Type 5660A - Removal and Replacement	11-10
Controller Boards type 5691A & 5694A Removal and Replacement	11-10
DC-DC Converter 5675A - Removal and Replacement	11-11
FHT681 cards - Removal and Replacement	11-11
LCD Display, Touch Screen, Touch Controller & Backlight Inverter - <i>Removal and Replacement</i>	11-13
Annunciator Panels LED's/Switch - <i>Removal & Replacement</i>	11-14
Sensor Assembly 11705235A/B/C/D & Interconnection cards 5697A - <i>Removal & Replacement</i>	11-15
Start Switch, Keypad and Loudspeaker - Removal & Replacement	11-15
Detector Removal and Replacement	11-15
Removal.....	11-16
Detector Replacement.....	11-17
Setting up Replacement Detectors for Use	11-17
PM12C GPIO (5707A).....	11-17
GPIO Replacement	11-17
PM12C Barrier Arm and Motor.....	11-17
Barrier Replacement	11-18
PM12C Powered Doors	11-18
Troubleshooting (Operational)	11-18
Normal Start-up (Boot-up) Operation.....	11-18
Unit "dead" (will not boot up) & charging LED is OFF.....	11-18
Unit "dead" (will not boot up) & charging LED is ON	11-19
Starts-up but Display is "Blank" & Fails Self Tests (no chimes).....	11-20
Will not run & displays "Out Of Service – Low Background Counts".....	11-20
Will Not Run & Displays "Out Of Service – High Background Conditions"	11-21
Fails Lamp or LED Tests.....	11-22
Fails Loudspeaker Test	11-22
Fails the LCD Display Test	11-23
Display Backlight Failure	11-23
Will Not Accept Valid Passwords	11-23
LCD Keypad Inoperative or Not Aligned.....	11-24
Will not Enter Background Mode.....	11-24
Or Locked in Background Mode	11-24
Locked in Measurement Mode	11-24
USB Output Data is Corrupted	11-25
Barriers will not OPEN/ CLOSE	11-25
Unreliable Door Operations.....	11-25
 Chapter 12 Spares List	 12-1
Recommended Spares List	12-1
Spares List	12-1
Drawings List (by Assembly)	12-2
Accessories List	12-3
 Chapter 13 Glossary of Terms	 1

Tables

Table 1 IEC (most of Europe) AC Power Circuit Wiring Colour Codes...4-8
Table 2 UK (including China) AC Power Circuit Wiring Colour Codes ..4-8
Table 3 USA AC Power Circuit Wiring Colour Codes4-9
Table 4 Canada AC Power Circuit Wiring Colour Codes4-9
Table 5 PM12 with 1" of Lead Shielding Centroid efficiencies6-12
Table 6- Probability - Sigma and %6-12

Figures

Figure 1 Example of PM12 User Screen5-69

Figure 2 Example of PM12 Annunciator Overlay5-70

Figure 3 Example of Result display on the PM12 User Screen5-87

Figure 4 Variation in the Vertical Plane6-14

Figure 5 Variation in response around the Body – horizontal plane6-15

Figure 6 Foot detector uniformity to 137Cs6-16

Figure 7 Statistical Limits of Counter Reliability9-8

Manual Revision History

Issue	Date	Name	Section(s)	Revision comments	Approval
Issue 1.0	04.03.08	C Hills	All	Initial Release	M Pottinger
Issue 2.0 Draft A	31.07.08	C Hills	All	Draft Release of PM12 User Manual for review – added information about variants	M Pottinger
Issue 2.0	30.10.08	C Hills	All	Second Release following review	M Pottinger
Issue 2.1	14.11.08	C Hills	All	Change to drawing numbers	M Pottinger
Issue 3	30.12.11	P Brown	Section 11.7	Added new process to replace hard disk	

Foreword

Throughout this document the term “**HEALTH PHYSICIST**” (HP) is used extensively. It refers to the Person, Persons or Team responsible for setting up day-to-day running and maintenance of the **PM12**. This may be an Instrument Maintenance Engineer, Radiation Safety Officer, local “Competent Person”, Departmental Manager or any other Responsible Person. The “**HEALTH PHYSICIST**” is the highest-level security role, uniquely responsible for setting and maintaining all lower order passwords. The HP would normally be responsible for installing and setting up the **PM12**, calibrating for user-defined nuclides, programming operating parameters and verifying correct operation of the instrument.

The term “**TECHNICIAN**” is used to refer to the personnel who normally repair and maintain the instrument in working condition. IMP personnel are designated to this role.

Personnel who are general users of the system and normally carry out routine diagnostic and test functions are allocated to the “**THERMOFISHER**” role.

The term “**USER**” refers to anybody associated with or operating the instrument in any way.

For more information on which menu options are available, see [Menu Roles \(page 5-6\)](#).

Chapter 1 Introduction

Personnel Monitor

The PM12 Personnel Monitor is a gamma-sensitive portal intended for contamination screening. Its simplicity of operation reduces the amount of training necessary for users and maintenance personnel. An Annunciator Screen, audible prompts and configurable measurement types are used in conjunction with a back-lit touch-screen LCD, large area coloured lamps and distinctive audible tones, to make controlled monitoring fast and simple.

Version "B" has no LCD fitted (see below for further information regarding Versions).

The outward appearance is similar to a doorway or portal opening. The electronics is housed in a compartment on the side of the instrument for easy maintenance. The Lead shielding (which may be 0.5 or 1.0 inch) screens the detectors and internal measurement volume from background radiation.

The "C" version has the exit route controlled by a pair of folding doors with a simple barrier entry mechanism. This adaptation considerably extends the footprint of instrument.

The PM12 uses eight identical large gamma-sensitive plastic scintillation detectors to surround the 28" x 78" (711 x 1981 mm) portal opening. Each detector is supported by an individual, microprocessor-based, interface board which controls the detector high voltage, supplies the amplifier/discriminator circuitry, and supports a serial communication channel. An annunciator board controls the audible and visual indicators and also serves as the master with respect to the X-Channel communication bus which interconnects the detector interface boards.

The PM12 requires no complicated displays or keypads and utilizes large lights, graphics, and audible instructions/tones to indicate operational status. The instrument is fitted with ingress and egress sensors which identify when the user enters or leaves the sensitive part of the instrument, and two sensors which identify whether the instrument is occupied. This ranging device may be used alone, or with the photoelectric switch, to suspend background updating and initiate the contamination survey. The alarming algorithm in the PM12 ensures the maintenance of a user selected Reliably Detectable

Activity (RDA), regardless of background radiation level, by continually adjusting count time and verifying user residence time in the portal.

Operational parameters are user programmable and stored on the instrument's hard drive. In addition, all operational parameters, including calibration and HV Scan data, are backed up onto an internal compact flash disk.

The instrument is provided with battery backup (including the powered door version "C") for continued operation in the event of a power failure.

The standard PM12 can have the following options in any combination:

A (C)	or	B	LCD or no LCD
0.5" (12.5mm)	or	1" (25mm)	Lead (L)
C			Power Doors + Barrier

The instrument build standard is therefore identified using the following nomenclature:

PM12A (or B or C) – nL - LN{-E}

An additional suffix of which signifies the user language may also be used e.g. –E for English speaking or –C for Chinese.

See [Specification \(page 3-1\)](#) for further information.

Features

- Bi-directional operation (open and gated versions)
- Statistical alarming algorithm with several selectable parameters including RDA, confidence level, false alarm rate and shielding factors.
- Large status indicator lights representing READY/CLEAR, RECOUNT, COUNT, ALARM and OUT OF SERVICE.
- Identification of contamination location through the use of a silhouette graphic with lights indicating which detector(s) alarmed. Low level distributed contamination is indicated by a separate light.
- Optional remote indicator unit featuring READY/CLEAR, RECOUNT, COUNT, ALARM and OUT OF SERVICE lights as well as chime and voice instructions.
- Battery backup for 6 hours
- Lead shielding (0.5" or 1" thick) to reduce background effects.

Chapter 2 Description

Main Frame Type 11705121 (11705302)

The Main Frame, type 11705121 (Versions A and B), is manufactured from a sturdy fabricated steel construction.

Main Frame, type 11705302 (Version C), has additional mounting frames to support the power doors.

Mounted within one of the corner members of the main frame, is the Electronics Chassis (containing the 5691A Controller Board, the 5694A IO expansion card and the 5660A Battery Controller Board), the keyswitch, loudspeaker and optional LCD display with touch screen assembly.

In Version B, the display assembly is replaced with a blanking panel containing a lock-able door for access to two USB sockets and a network connector.

Two other opposing corner members provide visual annunciation in the form of five operational lamps, an eight segment body mimic display to locate the contamination area, a user response push-button switch and a numerical two digit count-down status display.

Version C has a barrier arm assembly installed on the front annunciator corner member to gate entry.

The main power input is from the top of the portal to an IEC connector and integral power converter. An isolator (accessed from within the portal frame) has also been provided for removing power from the equipment

Power is distributed from here to the power doors assembly in Version C.

Two sets of HV and Amplifier Boards (four in total) are housed internally on either side-frame, as is the single battery in one of the side frames.

An interconnect card 5697A can be found at the top of each corner section to interface with the infra-red positional detectors mounted mid-section of the corner frames.

The inside of the frame can be clad with 0.5" (12.5 mm) of lead to minimise the effect of background radiation on the detectors. If required some areas can be increased to 1" (25mm) of lead.

The eight scintillation detectors are mounted on the inside faces of the portal, three either side, one at the top and one at the

foot. Flush fitting aluminium covers can be unlatched to gain access to the side detectors whilst a sturdy aluminium foot plate can be removed to reveal the foot detector. The top detector is accessed by removing a steel lid.

Version C uses a space in the top plinth to house an interface assembly (11705312/5707A) that allows the PM12 processor to control the folding doors and the entry barrier.

Two box sections are mounted in the base of the frame and run from front to rear. These box sections provide access for a Fork Lift truck once the foot plate assembly and detector has been removed.

PLEASE REFER TO [UNPACKING AND INSTALLATION \(page 4-1\)](#) FOR THE LIMITATION ON THE USE OF THESE CHANNELS.

Electronics Chassis Type 11705181

The Electronic Chassis, type 11705181 (comprising of one 5660A, one 5691A, one 5675A and one 5694), is mounted within the main corner assembly of the PM12 frame. Once the four retaining bolts are removed, the relevant corner member can be hinged open to reveal the chassis assembly. After undoing three fixing nuts and removing all connections the complete assembly can be detached from the corner member to facilitate maintenance.

Main Controller Board Type 5691A

The Controller Board, type 5691A, is motherboard to an ETX-PM(C) 800MHz Processor.

The ETX assembly provides PC functionality with 256Mb of RAM and the real time clock.

The motherboard interfaces directly to all other boards and external devices in the system via numerous connectors (not all are being used):

- The application software is retrieved from a 30 gigabyte (minimum) hard disk drive cabled via PL23. The drive also provides non-volatile storage for all data.
- PL12 provides a flash card storage medium for long term storage of important data
- 4 x USB connectors, SK5-8 are routed to the user interface panel on the side of the LCD display (if fitted)

- 1 x network interface SK10 routed to the user interface panel on the top of the main frame
- 1 x CRT monitor connection on SK6
- 1 x LCD drive on PL5 with backlight driver on PL9
- 1 x RS232 driver for LCD touch screen on PL1
- 1 x POWER connector PL6
- 1 x Loudspeaker connection for sound generator on PL3
- 1 x ISA extension connector on SK11

IO Expansion Board Type 5694A

This card extends the Controller board facilities to provide:

- 1 x I²C connector on PL2 for communicating with LED displays
- 8 x optically isolated inputs on PL13/14 for sensor inputs
- 1 x X-channel interface on PL8/9
- 1 x ISA interface connector on PL11

X-Channel GPIO Board Type 5707A

This card provides the necessary drive and monitoring circuitry required for controlling the rear folding doors and the front barrier arm motor. Communication with the card is established via the "X-Channel" bus picked up from the nearest HV & Amp assembly.

Battery Controller Board Type 5660A

The Battery Controller Board, type 5660A, manages the charging of a 12 volt sealed lead-acid battery. The whole electronics system is powered from the 5660A Board. The 5660A constantly senses the charge/discharge state of the battery and controls the charging voltage accordingly. The charging voltage is temperature compensated by means of a thermistor located on the battery. This helps to maximise the life time of the battery.

A momentary key-switch, located on the front of the main corner panel, allows power to be switched to the electronics provided the battery voltage is above a safe value (i.e. not discharged), even when mains power is absent. The key-switch

needs to be held ON for at least two seconds before the ON state is engaged.

The 5660A continues to monitor the terminal voltage of the battery during battery operation but will signal a shut-down if the battery discharges to a predetermined point, beyond which, it would suffer permanent damage and be difficult to recharge. A miniature fuse protects against over-current conditions.

The application software would normally regulate shut-down. In the event of the software losing control an emergency shut-down is possible by holding the key-switch ON for a minimum of 10 seconds (nominal).

DC-DC Converter Board Type 5675A

A proprietary DC-DC Converter pair produces regulated +5V and ± 12 V outputs directly from the Battery Controller Board, type 5660A. Power is then distributed via the Controller Board 5691A.

Scintillation HV and Amplifier Type 42543-0223 used in Assembly 11705186

The Scintillation HV and Amplifier Board, type 1, is a dual channel high voltage generator/scintillation amplifier pair. The HV generators are sub-assemblies (type 42543-0202) which are controlled by DACs (Digital to Analogue Converter) on the main pcb. The HV has a range between 0 and 1400 Volts, with a resolution of about 1 Volt.

The charge pulses arriving along the high voltage cable from the detectors are amplified and each fed to five discriminators and five associated counters, all controlled by the microprocessor on the main board.

The cards are interrogated via the X-channel bus to retrieve counter values generated every 100ms from a 5 second buffer.

Annunciators Type 11705182A/B

This assembly provides the front and rear visual displays necessary to inform the user of progress through the instrument. Two cards are involved, namely the 5672A and the 5700A. A push-button is integral with each assembly

Sensor Interconnect Type 5697A

This assembly is located in each of the four corner assemblies to route the infra-red circuits to the Electronic Chassis.

Scintillation Detector Type 5678A

Each of the eight detectors, type 5678A, is large area plastic scintillators wrapped in foil and plastic. A photomultiplier tube embedded in the plastic. Connection to the dynode chain assembly, mounted on the back of the tube, is via a light-tight gland. A single coaxial cable provides high voltage for the tube and carries the signals to the HV and Amplifier PCB via an MHV connector. For further information, see [Detectors \(page 3-3\)](#).

Power Door Option

The PM12C power doors are a proprietary item. These are originally fitted and tested by the supplier and are fully compliant with standard safety requirements. They can be operated independently from the application by gaining access to the associated controller which can be found inside the top of the RH corner section (viewed from folding door side). See [Troubleshooting \(Operational\) \(page 11-18\)](#) for control detail.

Appendix A Automatic Folding Door System contains more door specific information.

Chapter 3 Specification

The standard PM12 (with lead liners) is available with three options, in any combination:

- LCD or no LCD
- 0.5 or 1 inches (12.5mm or 25mm) of lead shielding (L)
- Power doors

Therefore, the PM12 type nomenclature used to identify the build standard is in terms of A or B or C & nL. The six variants are:

- PM12A – 05L
- PM12A – 10L
- PM12B – 05L
- PM12B – 10L
- PM12C – 05L
- PM12C – 10L

Operational Parameters

See [Params 1 \(page 5-13\)](#) and [Params 2 \(page 5-14\)](#) for information regarding the settings and defaults for the Operational Parameters.

Software Options

See [Options 1 \(page 5-8\)](#), [Options 2 \(page 5-10\)](#) and [Options 3 \(page 5-12\)](#) for information regarding the settings and defaults for the Software Options.

Default Messages

See [Messages \(page 5-21\)](#) for information regarding the settings and defaults for the Software Options.

Background Capability

Background capability is related to alarm threshold and statistical certainty requirements. Background subtraction is included in the measurement routines for the detectors. When the isotope of interest is of low energy level, the energy window can be changed to lower the background count rate thus allowing greater statistical certainty (see [Hv Power \(page 5-45\)](#) and [Selection of Detector Operating Parameters \(page 9-3\)](#)).

The mean background count rate is based on a 100 second count, which is maintained on a "rolling average" basis.

A significant change in the measured background count rate from the mean will cause the PM12 to discard the current mean value and restart background monitoring (see [Changing Background \(page 6-6\)](#)).

If, due to heavy use, the PM12 has been unable to measure background for 15 minutes, a 1 second background count is performed immediately after the current monitoring sequence. If no significant change is detected, the machine will be available for further monitoring. If a change in background is detected, further background measurements are performed until the PM12 detects a stable background (see [Changes to the Normal Background Monitoring \(page 5-75\)](#)).

When the mandatory 100 second background count has been accumulated, the monitoring time required to achieve the specified alarm level is calculated. Providing the monitoring time calculated falls within the maximum and minimum limits (see [Params 2 \(page 5-14\)](#)), the instrument will be ready for monitoring. If, however, the monitoring time calculated is greater than the maximum allowed, a "high background" condition exists and monitoring will be inhibited.

A high background condition indicates that the alarm level set and statistical certainties required are not achievable, under the current background conditions. This may be overcome when either the background falls or more suitable operational parameters are entered by the Health Physicist. It is advisable to check for residual contamination if this occurs unexpectedly or persists.

The lower the background field the more sensitive, stable and accurate the measurements will be.

Detectors

Eight Detectors

Type:	5678A
Construction:	Large area scintillation counter using a plastic phosphor type NE110 equivalent wrapped in foil and plastic.
Thickness:	2" (51 mm)
Area:	12" (305 mm) x 22" (559 mm) = 264"sq (170,495 mm ²)
Photomultiplier:	1" (25 mm) extended cathode
Shielding:	0.5" (12.5 mm) or 1" (25" mm) of aged lead on all external faces
Energy Response:	20 keV upwards (minimum detectable depends on liner material)

Detector HV settings

Operating voltages should normally be set up using the [NBR method \(page 9-5\)](#), although they may also be set up using the [Figure of Merit \(FOM\) method \(page 9-6\)](#) to yield the operating Photomultiplier voltages. These settings are determined and set using the HV Scan feature (Calibration|[HV Scan \(page 5-41\)](#)). The recommended values, based on the NBR optimization method, can be found in the Calibration certificate for each individual instrument.

Energy Window

This can have all thresholds adjustable under software control:-

Programmable Threshold 1	0 - 4095mV in 1 mV steps
Programmable Threshold 2	0 - 4095mV in 1 mV steps
Programmable Threshold 3	0 - 4095mV in 1 mV steps
Programmable Threshold 4	0 - 4095mV in 1 mV steps
Programmable Threshold 5	0 - 4095mV in 1 mV steps

Control

Instrument ON/OFF operation is via a momentary key-switch on the side panel. Entering the portal activates a sensor and suspends background monitoring until the portal is vacated. Entering the portal indicates a user is ready to be monitored and initiates a time-out period (see [Entering the Portal \(page 5-77\)](#)). Exiting the portal during monitoring aborts the measurement (see [Violations during Monitoring \(page 5-85\)](#)). Data entry and diagnostic functions are accessed through a touch screen but access is password protected.

Displays

LCD The integral back-lit LCD display provided is used in conjunction with the touch-screen for data entry and diagnostic functions. As well as duplicating any front panel LED display, the LCD can also provides comprehensive, user-friendly operational guidance, measurement results and instrument fault messages.

Lamps Five, bright, front and rear panel lamps show the instrument status at all times and give the user clear indication of the measurement result:

Green: READY / CLEAR
 White: RECOUNT
 Yellow: COUNT
 Red: ALARM
 Blue: OUT OF SERVICE

Charging LED A steady green LED on the side panel indicating that the mains is on and charging the battery.

Audible Indications

Chime	Measurement with a CLEAR result
Single Dong	End of a parameter counting sequence.
	OR
	Measurement Aborted
Periodic Dongs	Operator sequence ERROR
Rapid Dongs	Measurement exceeding ALARM ACTIVITY
Two Tone	Measurement exceeding HIGH LEVEL ALARM
Warble	Measurement Aborted

In addition to the audible indications give above, the following voice prompts are given, if enabled (see [Options 1 \(page 5-8\)](#)).

Enter identification.	If User ID Required is ticked, the user is requested to enter their ID before entering the portal (see User ID (page 5-78)).
Illegal Entry – Please leave the portal.	If User ID Required is ticked and the user enters the portal without entering their ID (see User ID (page 5-78)) If Unidirectional Mode is ticked and the user enters the portal from the wrong direction (see Direction of Entry (page 5-79)).

Please leave the portal.	If Unidirectional Mode is ticked, and the user has entered from the wrong side (see Direction of Entry (page 5-79)).
Please stand in the centre of the portal.	
Please stand with your front against the other wall.	
Please stand with your back against one wall.	Depending on the type of mode selected for monitoring (see Commence Monitoring (page 5-80)), instructions are given to the user where to position themselves in the portal.
Please stand against left wall.	
Please stand against right wall.	
Please turn to the side and press the button in front of you.	
Please return to position.	If during measurement, the user moves from the specified position (see Violations during Monitoring (page 5-85)).
Illegal Exit – Please re-enter the portal.	If the user exits the portal during measurement (see Violations during Monitoring (page 5-85)).
Clear – Please leave the portal.	If the measured contamination is below alarm levels, the user is advised to leave the portal (see CLEAR result (page 5-88)).
Measurement abandoned.	If the user exits the portal on the ingress side before the measurement is complete (see Violations during Monitoring (page 5-85)).
Instrument Out of Service.	If the portal is entered when the unit is out of service, the user is advised to leave the portal (see Out Of Service (page 5-94)).
Please continue to walk through.	If Walk Through mode is selected and the user pauses in the PM (see Walk Through Mode (page 5-81)).
Measurement Incomplete. Please re-enter the portal and start again.	If the user exits the portal on the egress side before the measurement is complete (see Violations during Monitoring (page 5-85)).
Please leave and re-enter the portal to start measurement.	If the user does not fully exit the portal on completion of measurement (see Violations during Monitoring (page 5-85)).

Note: The speaker volume is user adjustable in System|[Setup \(page 5-66\)](#).

Network Communications

An RJ45 connector provides for compliance with [IEEE 802.11](#) and is located in the roof access. All instruments present this connector at the main cable entry on the roof of the assembly. The PM12B, however, jumpers this to a connector behind the locked blanking plate.

USB Ports

A four port USB (version 1.1) hub is available on the 5694A. On the PM12A, two of the ports are presented on the bottom of the LCD display for peripheral interfaces (such as memory sticks, dongles, keyboard, mouse, etc.)

On the PM12B, two ports are found behind the locked blanking plate.

Power Requirements

Voltage	-	85 to 264 volts AC *
Frequency	-	47 to 63 Hz
Maximum power	-	65 V.A. *
Circuit Protection	-	Integral mains fuse in Power supply 250V 2A
Mains Isolation		An Isolator/thermal trip 230V 5A capacity

* The PM12C for CHINA is 230V only and requires an additional 100W maximum power. This is also routed through the isolator.

Battery Backup †

Battery type	Sealed lead-acid
Battery capacity	12 volts 17Ah
Battery support	typically up to 8 hours
Battery Fuse	4Amp PTC self-resetting

† The PM12C door controller has its own Nicad battery and charger that will provide in excess of 300 operational cycles (15 second rate). The PM12 battery capacity can be reduced by 10% in driving the barrier motor.

Dimensions (approximate)

Overall Dimensions (excluding LCD but including foot-plate)	PM12A & B	PM12C)
Height	86" / 2190 mm	91" / 2300 mm
Width	37" / 940 mm	41" / 1030mm
Depth	46.5"/ 1180 mm	46.5"/ 1180 mm
Dimensions of Internal Passage (all Versions)	Width	28" (710 mm) – 2.34 cubic feet
Weight - with 0.5" (12.5 mm) of lead shielding	PM12A(or B) - 05L	820 Kg (1800 lbs)
Weight - with 1" (25 mm) of lead shielding	PM12A(or B) - 1L	1000 Kg (2200 lbs)
	<hr/>	
	Note that the PM12C doors add approximately 150 Kg (330 lbs) to the overall weight.	
	<hr/>	

Environmental

Temperature and Humidity	Operational Temperature Range	+0°C to +45°C (32°F to 113°F)
	Storage Temperature Range	-10°C to +50°C(14°F to 122°F)
	Humidity Range	up to 95% RH non condensing

NOTE:

**USE BELOW +0°C (32°F) IS NOT RECOMMENDED – THE LCD DISPLAY WILL BECOME "SLUGGISH" BELOW THIS TEMPERATURE.
DO NOT STORE ABOVE +60°C (122°F)**

Magnetic Shielding There is no magnetic shielding.
Large external magnetic fields may reduce the measured value.

IP rating IP50

Environmental restrictions

- Not for use in flammable or explosive atmospheres
- For installation in "drip-free" locations only
- Do not expose to excessive dust pollution levels

Chapter 4 Unpacking and Installation

Inspect the portal for external damage. The ramp on the portal needs to be installed after the monitor is in position. The ramp support pieces are removable and allow the portal to be moved through a doorway. If these ramp supports need to be taken off, remove the two M6 hex bolts which hold the supports to the bottom of the portal. Once the portal is in position, reinstall the ramp support pieces. The ramp will be installed later.

Unpacking

The PM12 case should contain the following:

- Portal Monitor 1
 - Foot Tread Plate 1
 - Ramp assemblies 2
 - Head Detector (#1) 1
 - Foot Detector (#8) 1
 - 6 Side Detectors (#2 and #3 top, #4 and #5 middle, #6 and #7 bottom) and their Lead Shielding 6
- Note: May be shipped separately
- Combined Operational and Maintenance Manual
 - Pack containing ON/OFF keys, Dongle and Screen Cleaner
 - Calibration Certificate
 - Material Safety Data Sheet
 - PM12 Mains power cord (EC countries only)
 - 8mm plastic packing spacers 6
 - 13mm plastic packing spacers if only 0.5" Lead 6
 - 13mm plastic packing spaces for foot detector 4
 - Mounting Screws (M6 X 30) 24
 - Mounting Screws (M6 X 35) 72

- Installation diagrams:
 - Drawing No. 11705121 Main Frame Assembly
 - Drawing No. 11705170 Sht1 Corner Section Assembly Entry Side
 - Drawing No. 11705170 Sht2 Corner Section Assembly Exit Side
 - Drawing No. 11705170 Sht3 Detector Assembly
 - Drawing No. 11705170 Sht4 FHT, Battery, Top & Bottom Lead Shielding Assembly
 - Drawing No. 11705170 Sht5 Power Chassis and Earthing Assembly
 - Drawing No. 11705078 PM12 Lead Basic (0.5" Lead Kit)
 - Drawing No. 11705079 PM12 Lead Additional (1" Lead Kit)
 - Drawing No. 11705080 Wing Lead Assembly

To unpack the PM12

The PM12 will normally be transported on its side and will require to be lifted to its vertical position once the container has been opened.

First remove all packing material.

Remove any detectors and spacers.

Remove the foot plate and related ramp assemblies

The manual, Calibration certificate, Keys, Dongle and Mains power cord are packed inside a large envelope

Taking great care to observe all necessary "Health & Safety" constraints raise the portal monitor to its vertical position

CARE MUST BE TAKEN WHEN LIFTING THE EMPTY PM12 AS IT WEIGHS 0.5 TONS. A FORK-LIFT TRUCK OF SUITABLE LIFTING CAPACITY MUST BE USED TO MOVE AND TRANSPORT THE PM12 SAFELY, USING THE INTEGRAL FORK-LIFT CHANNELS. WHEELS, SKATES, SKIDS OR SIMILAR DEVICES MUST NOT BE USED TO MOVE THE PM12. PARTICULAR CARE SHOULD BE TAKEN ON GRADIENTS.

Inspect the Portal Monitor for any damage.

To unpack the PM12C

The instrument is packed and delivered in a vertical state to limit the additional work that would be required to remove and replace the folding door assembly. The LEAD is packed inside the base of the portal (to counterbalance the weight of the door control hardware) in a removable container.

Remove the foot-plate assembly and its supporting bracket

Remove the container that is packed with the eight detectors.

Use a fork-lift truck to remove the Lead container.

Remove any additional packaging that protects the folding doors from damage.

Mechanical Installation

Repositioning of the portal monitor will be difficult after installation of the lead shielding and the eight detectors. Place the portal in its intended location

The doors on the PM12C are shipped with the controller disconnected so that they can be opened/closed manually. They will need to be opened to install the lead with ease.

**WARNING: THE FULLY ASSEMBLED PM12 CAN WEIGH BETWEEN ¾ TO 1 TON.
ENSURE THE INSTALLATION SITE IS SUITABLY ROBUST**

If the instrument is to be bolted to the floor, install anchor bolts in accordance with the dimensions indicated in Drawing No. 11705121 for the Main Frame Assembly.

Remove the two foot tread plate members used to lock the side panels in position.

After they are unlocked, the two inner side panels are removed by carefully rotating the top edge away from the column and at the same time raising the bottom off the two locating pins. Take care not to scratch the roof panel in so doing.

Installation of Detectors and Lead Shielding

It is necessary to install the lead first. One or more of the following drawings will need to be at hand to locate the Lead and fixing bolts:

- Drawing No. 11705078 PM12 Lead Basic (0.5" Lead Kit)
- Drawing No. 11705079 PM12 Lead Additional (1" Lead Kit)
- Drawing No. 11705080 Wing Lead Assembly

CAUTION: TO AVOID LEAD CONTAMINATION, THE LEAD PIECES SHOULD BE HANDLED WITH GLOVES. WASH HANDS AFTER HANDLING. REFER TO THE *MATERIAL SAFETY DATA SHEET* THAT ACCOMPANIES THE LEAD.

LEAD IS AN EXTREMELY DENSE MATERIAL. SOME OF THE LARGE PIECES OF SHIELDING WEIGH UP TO 17 KGS. USE CORRECT HANDLING PROCEDURES TO AVOID PERSONAL INJURY.

First, start with the large side pieces (Part No. 11705013):

1. If 0.5" Lead is to be installed, then a packing layer will already be in place.
2. If the full 1" has to be installed, affix the first layer with two pairs of bolts. There are 12 pieces in total. Then complete the installation of the second layer (12 pieces again) using the remaining fixing holes and M6 X 35 bolts

Now install the vertical parts (Part Nos. 11705014 & 11705139) (12 off each) using M6 X 30 bolts.

The foot well must be equipped as follows:

1. Two pieces (Part No. 11705118) placed below the foot detector.
2. Two pieces (Part No. 11705120) placed to the front and rear of the detector.
3. Two pieces (Part No. 11705119) in the fork lift channels.
4. 13mm plastic spacer (Part No. 11705226).

Now place all eight detectors in position.

CAUTION: THE PM12 DETECTORS ARE DELICATE AND SHOULD BE HANDLED WITH CARE TO PREVENT JARRING. PLACE THE DETECTORS ON PADDED SURFACES FREE OF OBJECTS OR MATERIALS THAT COULD DAMAGE THE PROTECTIVE VINYL WRAPPING. DETECTORS SHOULD BE LAID FLAT ON THEIR LARGEST SURFACE. DO NOT STACK OR PLACE ANYTHING ON DETECTORS.

Installation of the Foot Detector (#8)

Each Detector is numbered on its side for location placement. These numbers correspond to those marked on the coaxial cables that will be found in each compartment.

1. It is advisable to fit the foot detector first and attach its coaxial cable (#8).
2. Install the two sets of ramp supports.
3. Place the foot tread plate on the base and screw down loosely.
4. The foot tread plate can be put in place for protection. Remember to install the two tread plate support members first!

Installation of the Side Detectors (#2 and #3 top, #4 and #5 middle, #6 and #7 bottom)

The corner frames of the PM12 may need to be unlocked to assist in fitting the six side detectors. Four bolts per section will need to be removed.

Starting from detectors #6 and #7 work upwards:

1. Fit the 8mm spacer to the rear of each detector using the thin double-sided tape provided
2. Place the detector assembly into position and strap in using the Velcro straps provided.

At this point, it is advisable to fit any **Wing** pieces of Lead (Part No. 11705015) (6 per side) using M6 X 35 bolts.

Installation of the Head Detectors (#1) and its Lead Shielding

Access to the Head Detector cubicle is obtained by removing the panel from the top of the upper plinth.

1. Place the Head Detector (#1) flat on the plinth, orienting the detector coaxial connector to meet with its mating cable #1.
2. Install the 1mm plastic liner on top of the detector for protection.
3. Install the two large pieces of lead (Part No. 11705011) carefully on top of the detector. The metalwork is so designed to lock the lead pieces into position.
4. Replace the top cover to retain the lead.

WARNING: THE ASSEMBLED PM12 CAN WEIGH UP TO 1.0 TON (THE PM12C CAN BE GREATER) ENSURE THE INSTALLATION SITE IS SUITABLY ROBUST.

THE PM12 IS NOT DESIGNED TO BE LIFTED IN THIS ASSEMBLED CONDITION. THE CENTRE OF GRAVITY IS HIGH AND THE UNIT WILL

BECOME UNSTABLE IF ANY ATTEMPT IS MADE TO USE THE FORK-LIFT CHANNELS TO MOVE THE PM12. IN ANY EVENT THE BOTTOM DETECTOR RESTRICTS ACCESS TO THE FORK-LIFT CHANNELS WHEN INSTALLED.

IT IS NOT RECOMMENDED THAT, EVEN WITH THE LEAD REMOVED, THE PM12C BE MOVED USING THE FORK-LIFT CHANNELS DUE TO THE ELEVATED WEIGHT OF THE DOOR HEADER BOX. THE GLASS DOOR PANELS SHOULD EITHER BE REMOVED OR PROTECTED BEFORE MOVING THE INSTRUMENT ANY DISTANCE.

Operational Setup

Note: If the portal monitor is to have power supplied in conduit, install conduit at this point. Provision is made at the right-hand rear corner at the top of the instrument for an installation plate to take $\frac{3}{4}$ " nominal conduit fittings.

The portal (PM12) has the flexibility to be configured in several ways. These include reduced time to count ([Quickscan \(page 6-10\)](#)) and background ([Quick Background \(page 6-10\)](#)), walk-thru or step mode, alarm types, minimum count time or maximum sensitivity mode and voice prompts – see [Setup Menu \(page 5-8\)](#) for further information.

Portal Location When several portals are installed at one facility, each should be given a unique location. By doing so, each portal's database and configuration settings can be easily identified. Set the desired location of the portal in [Setup \(page 5-66\)](#).

Barriers There are four different permutations that the barrier can be setup:

- Doors enabled/disabled
- Barrier enabled/disabled

Other combinations exist with the entry barrier if ingress needs limiting during a Background Update

See [Params 3 \(page 5-17\)](#).

Mode of Operation The portal may be operated in one of five modes:

- Walk-through
- Stand and Count
- Stand and Turn
- Two Step
- Three Step

If the operating parameters are compatible with Walk-Through operation, then use of the Walk-Through mode is appropriate. If however, the count time is excessive, a Stand and Count mode may be more appropriate.

See [Commence Monitoring \(page 5-80\)](#) for further information.

Optical Sensors Six infrared photoelectric light beams (sensors) are located to scan across the portal at about waist height as follows:

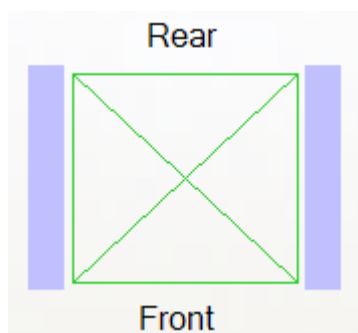

The sensors detect the physical presence and position of the individual in the portal.

Electrical Installation

Before proceeding with the electrical installation, ensure the PM12 has been mechanically installed as described in [Mechanical Installation \(page 4-3\)](#).

IMPORTANT: ENSURE CORRECT ELECTRICAL SUPPLY AND MAINS CONNECTOR WIRING FOR YOUR MAINS SUPPLY.

Battery State PM12 is air-freighted with all batteries discharged.

Electrical Installation

The PM12 is fitted with a 50 VA auto ranging power supply requiring a maximum input power of 65 VA. The PM12C has an additional 100VA requirement for the door control circuits.

DO NOT CONNECT THE MAINS SUPPLY.

A standard IEC mains connector is fitted in the roof access assembly, specified to IEC 320, EN60320. Only mating connectors of the PM12 standard should be used.

Although an isolator/ thermal trip is built into the equipment, the PM12 must be connected to a fused outlet capable itself of being isolated. The isolation switch should be close to the monitor and within reach of the operator.

The IEC power cord (IEC60446) must be connected to the electricity supply as follows:

WARNING: IT IS IMPORTANT TO CHECK LOCAL SUPPLY COLOUR CODES BEFORE CONNECTING ANY INSTRUMENT.

Table 1 IEC (most of Europe) AC Power Circuit Wiring Colour Codes

Function	Label	Colour, IEC	Colour, old IEC
Protective earth	PE	green-yellow	green-yellow
Neutral	N	blue	blue
Line, single phase	L	brown	brown or black
Line, 3-phase	L1	brown	brown or black
Line, 3-phase	L2	black	brown or black
Line, 3-phase	L3	grey	brown or black

Table 2 UK (including China) AC Power Circuit Wiring Colour Codes

Function	Label	Colour, IEC	Old UK Colour
Protective earth	PE	green-yellow	green-yellow
Neutral	N	blue	black
Line, single phase	L	brown	red
Line, 3-phase	L1	brown	red
Line, 3-phase	L2	black	yellow
Line, 3-phase	L3	grey	blue

Table 3 USA AC Power Circuit Wiring Colour Codes

Function	Label	Colour, Common	Colour, Alternative
Protective earth	PE	bare, green or green-yellow	green
Neutral	N	white	grey
Line, single phase	L	black or red (2nd hot)	
Line, 3-phase	L1	black	brown
Line, 3-phase	L2	red	orange
Line, 3-phase	L3	blue	yellow

Table 4 Canada AC Power Circuit Wiring Colour Codes

Function	Label	Colour, Common
Protective earth	PE	green or green-yellow
Neutral	N	white
Line, single phase	L	black or red (2nd hot)
Line, 3-phase	L1	red
Line, 3-phase	L2	black
Line, 3-phase	L3	blue

When all installation work has been carried out, follow the setting up procedure described in [Setting Up Procedure \(page 9-1\)](#).

Reconnection of the battery to the PM12C power door cubicle requires the drive mechanism cover to be removed from the top of the doors. Return the marked power plug to its mating connector as shown in the picture below:

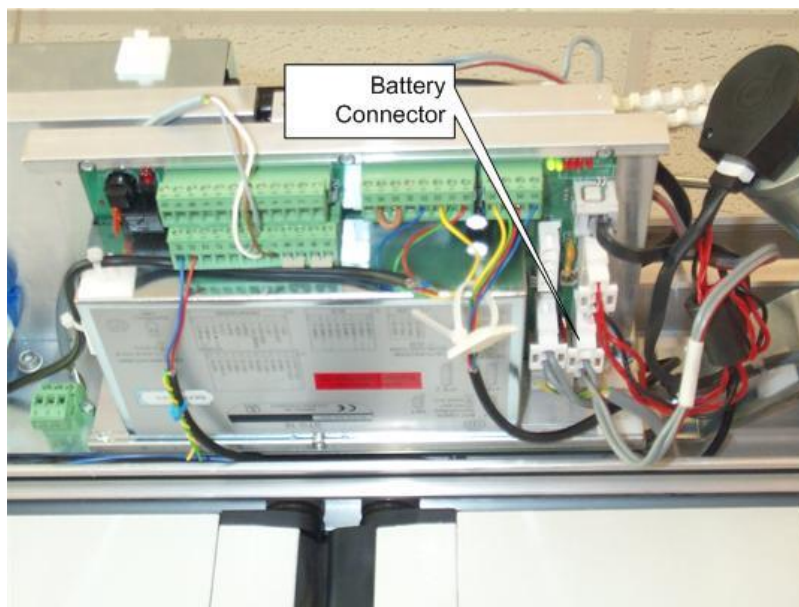

Beware that as soon as the power is restored and there is reserve charge left in the battery, the power door control system will move the doors to calibrate itself. This only takes a few minutes.

Printer Installation

Unpack the Printer (if supplied) and locate it as required in the vicinity of the PM12. Configure the printer as detailed in the manufacturers hand book.

ENSURE the printer is set to the relevant mains setting before plugging the power cable in.

The printer should be used with the USB interface, simply by connecting to the PM12 with the USB cable supplied.

Notes on Orientation and Positioning

The large area detectors of the PM12 make it very sensitive to changes in background. Therefore, it is recommended that the installation site be chosen for background stability and to minimise the effect of statistical fluctuations.

It is recommended that the PM12 be installed away from active areas to suit both these needs.

If the background field at the installation site is directional it is recommended that the PM12 be installed so that the side of the Cabinet faces the field source. This orientation should minimise the penetration and scatter of background radiation around the walk-through aperture, although the advantage is small.

Chapter 5 Operating Instructions

Operational States

There are two operational states for the **PM12**:

ADMINISTRATOR Mode – this mode allows the instrument to be configured, calibrated and diagnostic checks to be run. Access to this state requires a username and password. See [Administrator Mode \(page 5-1\)](#) for further details.

USER Mode – this mode supports the normal monitoring of samples. Any user can operate the instrument in this state. See [User Mode \(page 5-68\)](#) for further details.

Administrator Mode

Note that communications with the PM12 is via a touchscreen and this manual has been written primarily giving instructions for the touchscreen commands. It is also possible to use a USB keyboard and mouse to communicate with the PM12.

Using the Touchscreen Functions

This section describes the methods that are common to all the entry and data viewing operations in the Parameter Mode menus.

When using the touchscreen, directly touch the menu options on the screen when selecting a function.

CAUTION: IT IS ADVISED TO USE A CLEAN FINGER TO TOUCH THE SCREEN. DO NOT USE SHARP OBJECTS ON THE TOUCHSCREEN SUCH AS PENCILS, PENS, SCREWDRIVERS ETC.

Number Functions

When touching the screen in a numerical field, the following number pad appears:

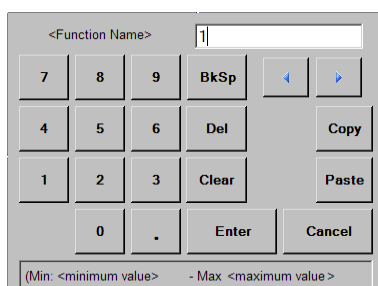

Note that the Function Name, minimum and maximum values are displayed depending on the function selected.

If an illegal value is entered, the value is highlighted in red:



Alpha-numerical Functions

When touching the screen in an alpha-numerical field, the following keyboard appears:

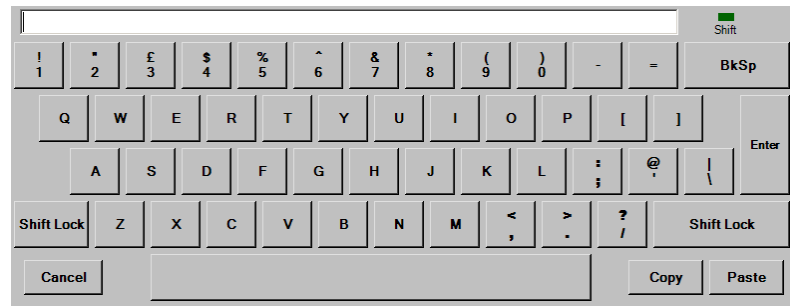

Pre-defined Functions

When touching the screen in a pre-defined field, the following window appears:

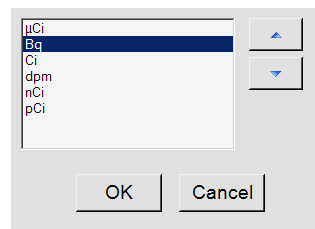

Date Functions

When touching the screen in a date field, the following date selection window appears:

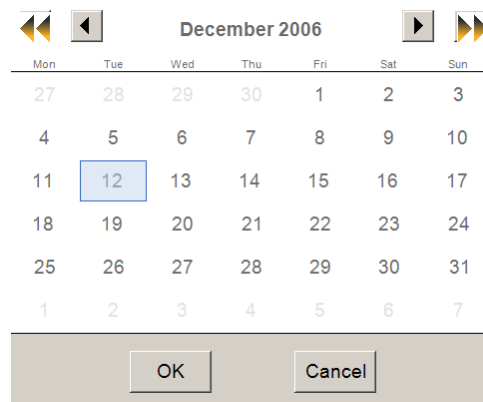

File Location Functions

When touching the screen in a File Location field, the following Drive selection window appears:

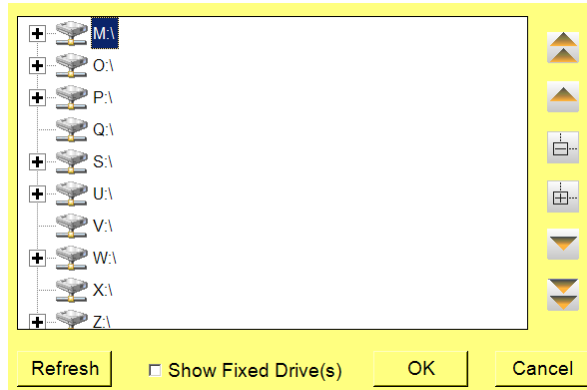

Button Types

The Button types are listed below:



Direction Arrows steps through the menu options



Drop-down lists allows you to select a pre-defined option from the list.

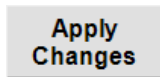

Action button show the process taken when selected.

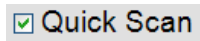

Tick Boxes show independent options that you can choose to set, or mark. The choice can be toggled on and off by touching on the box.

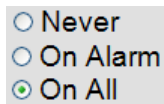

Radio Buttons show mutually exclusive options; choosing one option automatically clears the others. The black dot shows the selected option.

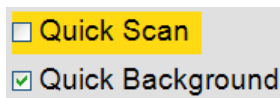

Note that changes made to fields are highlighted until applied or cancelled.

Gaining Access to the Administration Mode

Administration mode is entered by pressing on 'PM12' in the bottom left-hand corner of the touchscreen when the PM12 is in Background Checking mode. The Entering Admin Mode window is displayed requesting to select a User:

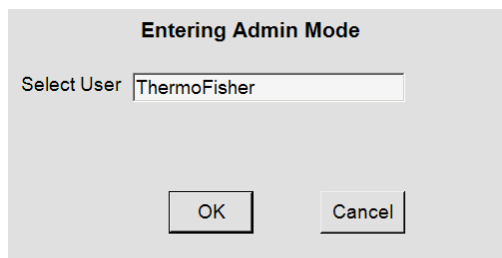

To select a different user to the one displayed, press the User field of the touchscreen. Select Health Physicist, Technician or ThermoFisher using the Up/Down arrow and select OK. See [Foreword \(page xv\)](#) for more information regarding the roles.

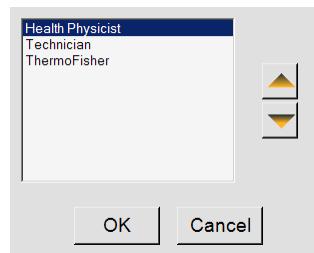

In the Entering Admin Mode window, select OK for the ENTER PASSWORD window (see below) and the Alpha-numeric keyboard to be displayed:

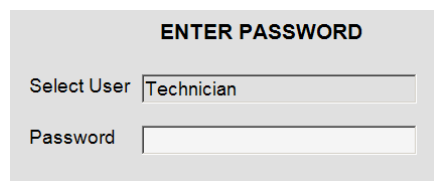

Enter the password using the keyboard and select OK to enter the Administration Mode – note that the Diagnostics – Detector window is initially displayed (see Passwords ([page 5-67](#)) for details). The various options available in the Administration Mode are displayed in [Menu Roles \(page 5-6\)](#).

Entering an invalid password will display the following message:

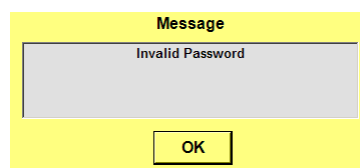

Press OK to re-display the Enter Admin Mode screen.

Moving through the Menus

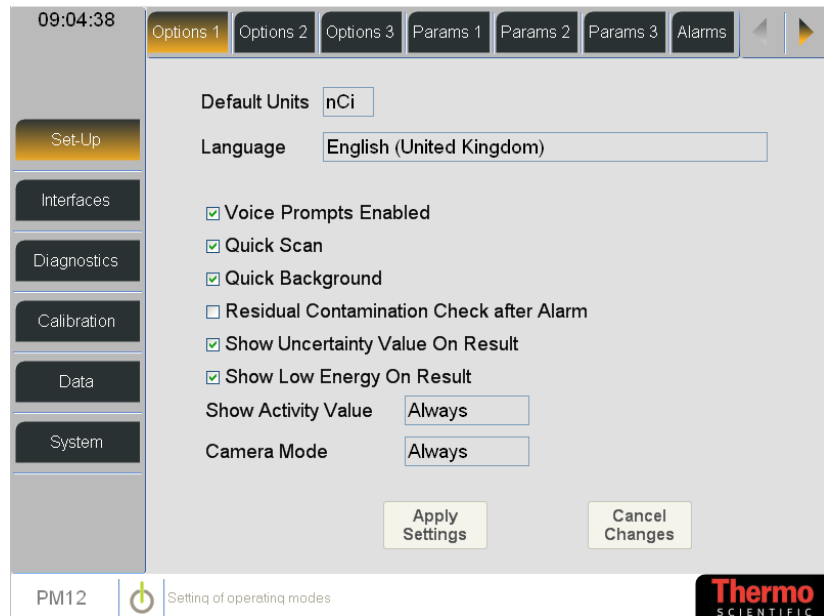

To move through the menus, select the Main menu option on the left-hand side of the window to display the sub-menus available. Then select the sub-option from the top. Note that a full list of menu and sub-menu options is displayed in Menu Roles below.

Selecting Detectors

On some screens, an option is available to select Detectors, where:

- 1 = Head
- 2 and 3 = Side, top
- 4 and 5 = Side, middle
- 6 and 7 = Side, bottom
- 8 = Foot

For further information regarding Detectors, see [Scintillation Detector Type 5678A \(page 2-5\)](#).

To select individual Detectors, press the corresponding number in the graphic:

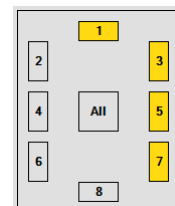

To select all Detectors, press the All button in the graphic:

Note that the All button changes to None and all the Detectors are highlighted.

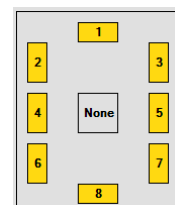

To select all Detectors, press the None button in the graphic:

Note that the None button changes to All and none of the Detectors are highlighted.

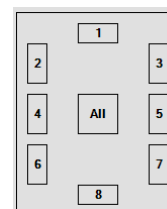

Menu Roles The following options are available depending on the role selected:

			Role Name		
Main Menu	Sub-menu	See Page	Health Physicist	Technician	Thermo Fisher
Set-Up	Options 1	5-8	√		√
	Options 2	5-10	√		√
	Options 3	5-12	√		√
	Params 1	5-13	√		√
	Params 2	5-14	√		√
	Params 3	5-17	√		√
	Alarms	5-18	√		√
	Battery	5-20			√
	Messages	5-21	√		√
	Interfaces	Plug-ins	5-21	√	
Cameras (option only available if installed)		5-22	√		√
Diagnostics	Detectors	5-28	√	√	√
	Information	5-29	√	√	√
	Counts	5-30	√		√
	Variance Test	5-30	√		√
	Alarm Check	5-32	√	√	√
	Sensors	5-33	√	√	√
	Barriers	5-34	√		√
	Battery	5-34	√		√
	Calibration	Efficiencies	5-35	√	√
Cal Check		5-35	√	√	√
Calibration Selection		5-40	√		√
HV Scan		5-41	√		√
Thresholds		5-45			√
HV Power		5-45	√	√	√
Attenuation		5-46	√		√

			Role Name		
Main Menu	Sub-menu	See Page	Health Physicist	Technician	Thermo Fisher
Data	Reports	5-48	√		√
	Archives	5-65	√		√
System	Actions	5-65	√		√
	Setup	5-66	√		√
	Version	5-66	√		√
	Passwords	5-67	√		√
	Data Retention	5-67	√		√

Exiting the Administration Mode

To exit Administration mode, press on 'PM12' in the bottom left-hand corner of the touchscreen. Login to the Administration mode – see [Gaining Access to the Administration Mode \(page 5-3\)](#).

Select the System main menu option and then the Actions sub-menu option. Select the Exit Application button. A warning message is displayed asking for confirmation:

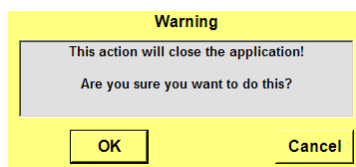

Select OK to exit and Cancel to abandon the exit process. For further information, see [Actions \(page 5-65\)](#).

Upon exiting from the Keypad Parameter Mode, a Residual Contamination check will be enforced if the previous operational state was an Alarm or Residual Contamination condition – see [Notes regarding Residual Contamination Check \(page 5-92\)](#).

Setup Menu

Options 1

Select Set-Up|Options 1 to customise the PM12's operation:

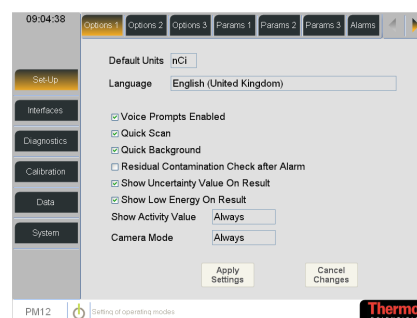

Description of options:

Field Name	Description
Default Units	<p>Use the pre-defined window to select a unit from one of the following:</p> <ul style="list-style-type: none"> • μCi • Bq • dpm • nCi • pCi <p>This changes the displayed activity units for the PM12. Default: dpm</p>
Language	<p>Use the pre-defined window to select a language. This changes the displayed language for the PM12.</p>
Voice Prompts Enabled	<p>Tick this option to enable voice prompts to be audible.</p> <p>For more information regarding the prompts and where they are used, see Audible Indications (page 3-4).</p> <p>Default: OFF</p>
Quick Scan	<p>This option may be enabled to allow "real-dirty" or "real-clean" to be identified before end of monitoring period.</p> <p>Also see Quick Scan Period in Params 2 (page 5-14).</p> <p>Quick Scan is disabled during automatic and manual recounts.</p> <p>Quick Scan does not apply to Walk Through Mode (see Options 2 (page 5-10)).</p> <p>Default: OFF</p>
Quick Background	<p>Tick this option to reduce the time taken to establish a background, i.e. background is considered valid as soon as alarm requirements are met. If this option is not ticked, the time taken to establish a background is 100 seconds.</p> <p>Default: OFF</p>

Residual Contamination Check after Alarm	Tick this option to enable a Residual Contamination Check to be automatically performed following an Alarm. For further information regarding Residual Contamination Checks, see Residual Contamination Check (page 5-92) .
Show Uncertainty Value on Result	<p><i>Note that the "Show Uncertainty Value on Result" and "Show Activity Result" option combine to display the information on the result screen.</i></p> <p>When this option is ticked, the Uncertainty value is included in the result if the Activity is also displayed. See Monitoring Result (page 5-87) for more information.</p> <p>Default: OFF</p>
Show Low Energy On Result	<p>When this option is ticked, any low gamma detection is displayed. See Monitoring Result (page 5-87) for more information.</p> <p>Default: OFF</p>
Show Activity Value	<p>Use the pre-defined window to select an option from one of the following:</p> <ul style="list-style-type: none"> • Never – the Activity Value will not appear in the result screen • On Alarm – the Activity Value will only be displayed if an alarm occurs • Always – the Activity Value will be displayed for all results. <p>See Monitoring Result (page 5-87) for more information.</p> <p>Default: Never</p>
Camera Mode	<p><i>Note that this option is only available if camera(s) have been installed (see IDS Camera (page 5-23)) – it is not displayed in the picture above.</i></p> <p>The camera(s) can be set to save a snapshot on the hard drive on entry to the portal. The image of the person is saved to the hard drive only on a successful measurement – if the person abort the measurement, e.g. by reversion out of the portal, the image is discarded.</p> <p>Use the pre-defined window to select an option from one of the following:</p> <ul style="list-style-type: none"> • Never – a snapshot will never be taken of the user • On Alarm – a snapshot of the user will only be taken if an alarm occurs • Always – a snapshot of the user will be taken for all results. <p>Default: Never</p>

Options 2 Select Set-Up|Options 2 to customise the PM12's operation:



Description of options:

Field Name	Description
Step Mode	Use the pre-defined window to select a mode from one of the following: <ul style="list-style-type: none"> • Walk Through • Single Step • Two Step • Three Step • Stand and Turn Default: Single Step See Commence Monitoring (page 5-80) for more information.
Complete All Steps	Tick this option to ensure that all steps (selected in the option above) are completed before a result is displayed. If this option is not selected, the PM12 will display an alarm (if detected) following any step and the measurement process is terminated. Default: OFF
Unidirectional Mode	Tick this option to ensure that the unit only operates in a unidirectional mode, i.e. the user may only enter the portal from a designated side. Note that if this option is ticked, the Entry Side option is enabled (see below). Untick this option to ensure that the unit may be entered from either side. Default: OFF
Entry side:	Note: Use the pre-defined window to select a side from which the user must enter the portal: <ul style="list-style-type: none"> • Front • Back The following message is displayed if the user enters the portal from the wrong side: <div style="background-color: black; color: white; padding: 5px; text-align: center; margin: 10px 0;"> Warning Entered by the wrong side </div> Default: Front

User Id Required	<p>This option ensures that the user must enter his ID using the barcode reader before the portal will operate.</p> <p>The following message is displayed:</p> <p>Enter Id and then Enter</p> <p>See User ID (page 5-78) for information on how this is implemented in the Monitoring process.</p> <p>Default: OFF</p>
Exit Direction Restricted to Ingress Side on Fail	<p><i>Note that If Step Mode = Walk Through, this option is greyed out.</i></p> <p>This option will ensure that the user has to exit the same direction as they entered the portal if the monitoring fails or the alarms sound. The following message is displayed:</p> <p>Please Re-enter the Portal</p> <p>See Exiting the Portal (page 5-93) for information on how this is implemented in the Monitoring process.</p> <p>Default: OFF</p>
User Can Cancel Alarm Sound	<p>This option allows the user to press the Alarm Acknowledge button when an alarm has taken place.</p> <p>See ALARM Acknowledge (page 5-91) for more information on clearing the alarms.</p> <p>Default: OFF</p>
Failure Display requires Supervisor Acknowledge	<p>This option ensures that a supervisor has to insert a dongle and press the Alarm Acknowledge button when a failure (or alarm) has taken place.</p> <p>Note that the alarm will continue to display and sound until the supervisor acknowledges it.</p> <p>See ALARM Acknowledge (page 5-91) for more information on clearing the alarms.</p> <p>Default: OFF</p>
Alarm Duration after Exit (s)	<p>This is the length of time that the alarm displays/sounds after the user has exited the portal.</p> <p>See ALARM Acknowledge (page 5-91) for more information on clearing the alarms.</p> <p>Values: 0 to 300 s</p> <p>Default: 2 seconds</p>
Exit Violation Duration (s)	<p>This is the length of time that the Exit Violation message is displayed.</p> <p>The following message is displayed:</p> <p>Exit Violation</p> <p>Values: 0 to 300 s</p> <p>Default: 5 seconds</p>

<p>Id Timeout Period (s)</p>	<p>This is the maximum length of time allowed between entering the User ID and entering the portal. It is also used as the maximum length of time (in seconds) allowed for the user to present their ID after entered the portal.</p> <p><i>Note that User Id Required (see above) has to be ticked for this option to be effective.</i></p> <p>Values: 0 to 300 s Default: 10 seconds</p>
<p>Portal Approach Time (s)</p>	<p>This is the maximum length of time following entry to the portal that the user has to move to the correct position in the portal.</p> <p>Values: 0 to 300 s Default: 2 seconds</p>
<p>Maximum Clear Display Time (s)</p>	<p>This is the length in time that the Clear Display is displayed before an alarm is sounded (see Restart Required (page 5-89)).</p> <p>Values: 0 to 60 s Default: 10 seconds</p>

Options 3 Select Set-Up|Options 3 to customise the PM12's operation:

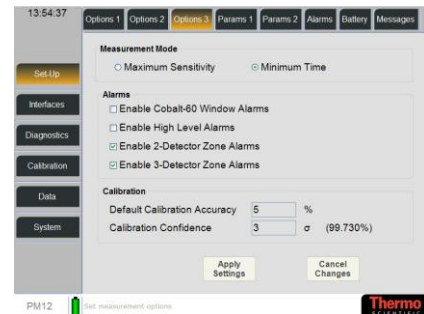

Description of options:

Field Name	Description
<p>Measurement Mode</p>	<p><i>Note that if Step Mode = Walk Through, this field defaults to Maximum Sensitivity.</i></p> <p>Click on one of the radio buttons to select one of the following:</p> <ul style="list-style-type: none"> • Maximum Sensitivity – the alarm threshold is determined by Probability of False Alarm (see Params 2 (page 5-14)) • Minimum Time – Effective Alarm level includes Probability of Detection (see Params 2 (page 5-14)) <p>Default: Maximum Sensitivity</p>
<p>Enable Cobalt-60 Windows Alarms</p>	<p>If this option is greyed out, then your PM12 is not configured to use Cobalt Coincidence Monitoring. If you require this utility, please contact Thermo Fisher Scientific for further information.</p> <p>Tick this option to enable Cobalt-60 alarms.</p> <p>Default: OFF</p>

Enable High Level Alarms	<i>Note that if Measurement Mode = Maximum Sensitivity, this option is greyed out.</i> Tick this option to enable High Level alarms. Default: OFF
Enable 2-Detector Zone Alarms	Tick this option to include Dual Zone alarms Default: OFF
Enable 3-Detector Zone Alarms	Tick this option to include Triple Zone alarms. Default: OFF
Default Calibration Accuracy (%)	<i>Note that this is a view only field.</i> This is the default Calibration Accuracy used in the Calibration Check utility - see Cal Check (page 5-35) . It is used, along with the background measurement, determines the count time required with the PM12 is being calibrated. Values: 0.5 to 10% in 0.1% steps Default: 1.00 %
Calibration Confidence (σ)	<i>Note that this is a view only field.</i> This factor affects the monitoring time of calibration. Values: 0.1 to 4 sigma in 0.1 sigma steps Default: 2

Params 1 Select Set-Up|Params 1 to customise the first set of Operational Parameters:



Description of options:

Field Name	Description
Low Background Alarm (cps)	If a background measurement falls below this value (counts per second), a detector failure will occur. Values: 0 to 99,999 cps (0 to disable) Default: 50cps
High Background Alarm (cps)	If a background measurement goes above this value (counts per second), a detector failure will occur. Values: 0 to 99,999 cps (0 to disable) Default: 5000cps
RCC Contamination Threshold (σ)	This is the statistical increase during a Residual Contamination Check compared to the background measurement. Values: 0.1 to 7 sigma in 0.1 sigma steps Default: 7 σ

<p>Low Energy Ratio Threshold</p>	<p>This facility utilizes information on the ratio between count rates above thresholds to decide whether the radioactivity present is emitting photon radiation of low energy (i.e. <400 keV). Any ratio of T1/T2 which exceeds this threshold will be deemed low energy. See NBR Method (page 9-5) for further information.</p> <p>Values: 50 to 10,000 Default: 100</p>
<p>Default Calibration Source</p>	<p>Use the pre-defined window to select a default source. For a list of Sources, see Cal Check (page 5-35).</p> <p>Values: from source database</p>
<p>Calibration Required Interval (days)</p>	<p>This is the number of days since that last calibration date before the unit needs to be calibrated again. See Out of Calibration (page 5-73) to view the message displayed on the unit when out of date and Cal Check (page 5-35) for information of the last Calibration Date.</p> <p>Values: 1 to 400 days (0 to disable) Default: 0</p>
<p>Background Logging Interval (hours)</p>	<p>Select an interval between 1 and 168 hours for the PM12 to periodically log the background. Select 0 to disable the periodic logging.</p> <p><i>Note that each time a mandatory 100 second background is performed the backgrounds for each detector will be logged to the database.</i></p> <p>Values: 1 to 168 hours (0 to disable) Default: 0</p>
<p>Out of Service Recovery Interval (mins)</p>	<p>When the unit is Out Of Service (page 5-94), the system automatically clears the error after the Out of Service Recovery Interval has passed. Select 0 to disable the Recovery Interval.</p> <p>Values: 0 to 60 mins Default: 0</p>

For further information regarding these options, contact Thermo Fisher Scientific.

Params 2 Select Set-Up|Params 2 to customise the second set of Operational Parameters:

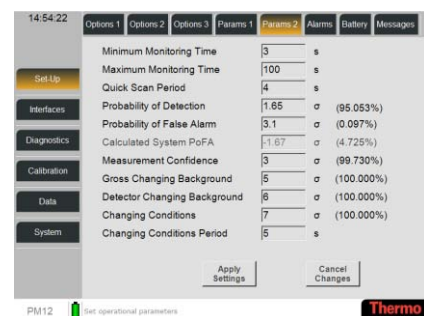

Description of options:

Field Name	Description
Minimum Monitoring Time (s)	<p><i>Note that the Minimum monitoring time must be equal to or less than Maximum Monitoring Time.</i></p> <p>This is the Minimum time for which contamination is monitored. This field is used in conjunction with the Maximum Monitoring Time.</p> <p>Values: 3 to 300 s Default: 5 s</p>
Maximum Monitoring Time (s)	<p><i>Note that the Maximum monitoring time must be equal to or greater than Minimum monitoring time. It must be set to a high enough value to prevent a high background fault.</i></p> <p>This is the Maximum time for which contamination is monitored. A monitoring time is calculated by the PM12 to meet the background and the statistical requirements. For given alarm and statistical requirements this parameter will limit the background count-rate allowed.</p> <p>To achieve a fixed monitoring time, set the minimum and maximum monitoring times to the same value.</p> <p>Values: 3 to 300 s Default: 100 s</p>
Quick Scan Period (s)	<p>This is the length of time (in seconds) for the Quick Scan to run (see Options 1 (page 5-8)).</p> <p>Values: 3 to 60 s Default: 10 s</p>
Probability of Detection (σ)	<p>This is the probability that exactly one alarm Level of contamination will cause and alarm.</p> <p>For further information, see Description of Parameters Used in Calculations.</p> <p><i>Note that the Probability of Detection is also expressed as a percentage in parentheses.</i></p> <p>Values: 0 to 10 sigma in 0.1 sigma steps. Default: 1.65 σ</p>
Probability of False Alarm (σ)	<p>This value is the probability that a false alarm will NOT be given during a measurement. This probability is used by PM12 to determine the monitoring time and the Effective Alarm Level and Minimum Detectable Activity.</p> <p>For further information, see Description of Parameters Used in Calculations (page 6-3).</p> <p><i>Note that the Probability of False Alarm is also expressed as a percentage in parentheses.</i></p> <p>Values: 0 to 10 sigma in 0.1 sigma steps. Default: 3.1 σ</p>

Calculated System PoFA (σ)	<p><i>Note that this option is greyed out.</i></p> <p>This is the Probability of False Alarm that has been automatically calculated by the system.</p> <p><i>Note that the Calculated System PoFA is also expressed as a percentage in parentheses.</i></p> <p>Values: 0 to 10 sigma in 0.1 sigma steps.</p>
Measurement Confidence (σ)	<p>The instrument uses this figure to calculate the effective alarm level. It is the number of standard deviations measured against the Alarms (see Alarms (page 5-18)).</p> <p><i>Note that the Measurement Confidence is also expressed as a percentage in parentheses.</i></p> <p>Values: 0.1 to 10 sigma in 0.1 sigma steps.</p> <p>Default: 2 σ</p>
Gross Changing Background (σ)	<p>This statistical variable is used by PM12 to determine if a changing background condition exists on all detectors.</p> <p><i>Note that the Gross Changing Background is also expressed as a percentage in parentheses.</i></p> <p>Values: 0.1 to 7 sigma in 0.1 sigma steps</p> <p>Default: 5 σ</p>
Detector Changing Background (σ)	<p>This statistical variable is used by PM12 to determine if a changing background condition exists on a single detector.</p> <p><i>Note that the Detector Changing Background is also expressed as a percentage in parentheses.</i></p> <p>Values: 0.1 to 7 sigma in 0.1 sigma steps</p> <p>Default: 7 σ</p>
Changing Conditions (σ)	<p>This statistical variable is used by PM12 to determine if a changing measurement condition exists.</p> <p><i>Note that the Changing Conditions is also expressed as a percentage in parentheses.</i></p> <p>Values: 0.1 to 7 sigma in 0.1 sigma steps</p> <p>Default: 7 σ</p>
Changing Conditions Period (s)	<p>This is the length of time used by PM12 to determine if a changing measurement condition exists.</p> <p>Values: 2 to 30 s</p> <p>Default: 3 s</p>

Params 3 Select Set-Up|Params 3 to customise the third set of Operational Parameters:

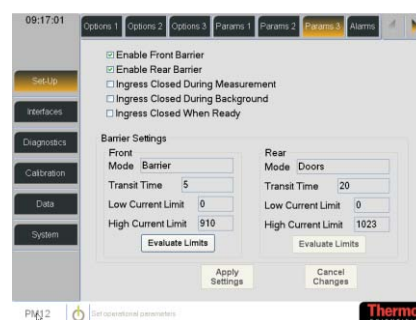

Description of options:

Field Name	Description
Enable Front Barrier	Tick this option to enable the Front Barrier – see below for settings.
Enable Rear Barrier	Tick this option to enable the Rear Barrier – see below for settings.
Ingress Closed During Measurement	<i>Note that this option is greyed out unless the Enable Front and Rear Barrier options are ticked.</i> Tick this option to prevent entry into the PM12 while measurement is taking place.
Ingress Closed During Background	<i>Note that this option is greyed out unless the Enable Front and Rear Barrier options are ticked.</i> Tick this option to prevent entry into the PM12 while a background measurement is taking place.
Ingress Closed When Ready	<i>Note that this option is greyed out unless the Enable Front and Rear Barrier options are ticked.</i> Tick this option to prevent entry into the PM12 when the Ready message is displayed.
<i>Note that the Barrier Settings are only displayed when logged in as ThermoFisher (see Menu Roles (page 5-6)). The Front Barrier Settings are displayed if the Enable Front Barrier option is ticked. The Rear Barrier Settings are displayed if the Enable Rear Barrier option is ticked.</i>	
Barrier Settings – Front and Back	
Mode	Use the pre-defined window to select the type of Barrier that may be attached to the unit: <ul style="list-style-type: none"> • Doors • Barrier • Unpowered Doors • Turnstile See Barriers (page 4-6) for details regarding the types of Barriers that may be used with the PM12.
Transit time	This is the time that is allowed for the worker to pass through the barrier. Values: 0 to 65535 seconds

<p>Low Current Limit</p>	<p><i>Note that this field is greyed out unless Barrier Mode is selected.</i></p> <p>This is the Low Current Limit below which the barrier will stall (see Evaluate Limits below for further explanation).</p> <p>Values: 0 to 65535 milliamps</p>
<p>High Current Limit</p>	<p><i>Note that this field is greyed out unless Barrier Mode is selected.</i></p> <p>This is the Low Current Limit above which the barrier will stall (see Evaluate Limits below for further explanation).</p> <p>Values: 0 to 65535 milliamps</p>
<p>Evaluate Limits</p>	<p><i>Note that this button is greyed out unless Barrier Mode is selected.</i></p> <p>Select this button to commence a test sequence for the Barrier Mode which will check the operation of the Barrier and detects the Low and High Current Limits.</p> <p>IMPORTANT – this button activates the Barrier to open and close. The actual values for the Low and High Current Limits are inserted into these fields. However, it is strongly advised that the Current Limit fields are set to the following values:</p> <p>Low Current Limit = between 0 and 10</p> <p>High Current Limit = 1.5 x actual High Current Limit</p> <p>This will prevent the stall detection operating on the Barrier during normal usage.</p>

Alarms Select Set-Up|Alarms to select the Active Calibration Stream and set the alarms:

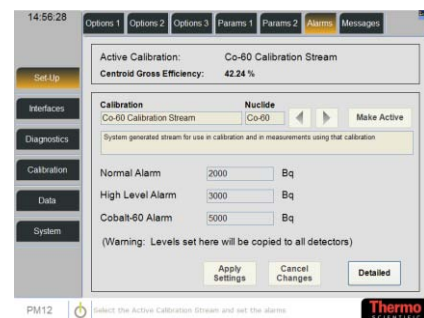

Description of options:

Field Name	Description
<p>Calibration / Nuclide</p>	<p>Use the direction arrows to change the Calibration type. When the type is correct, select the Make Active button</p> <p><i>Note that a description of the Calibration Type is displayed in the field below.</i></p>
<p>Normal Alarm (default unit)</p>	<p>This is the detected activity at which PM12 will indicate an Alarm.</p> <p>Values: 0 to 10,000,000 (Any unit).</p> <p>Default: 5000.0 dpm</p>

<p>High Level Alarm (default unit)</p>	<p>This field is enabled if Enable High Level Alarms is ticked – see Options 3 (page 5-12). This is the detected activity at which PM12 will indicate an High Level Alarm Values: 0 to 10,000,000 (Any unit). Default: Must be input</p>
<p>Cobalt-60 Alarm (default unit)</p>	<p>This field is enabled if Enable Cobalt-60 Window Alarms is ticked - see Options 3 (page 5-12). This is the detected activity at which PM12 will indicate a Cobalt-60 Alarm. Values: 0 to 10,000,000 (Any unit). Default: Must be input</p>

It is possible to set alarms for specific and groups of detectors by selecting the Detailed button:



Description of options:

Field Name	Description
<p>Centroid</p>	<p>These are the alarms for the sum of all the detectors. Click on the required field to change the value (see Selecting Detectors (page 5-5) for information on selecting single, multiple or all detectors). <i>Note that the High and/or Cobalt columns are displayed if Enable High Level Alarm and/or Enable Cobalt-60 Windows Alarm is ticked - see Options 3 (page 5-12).</i></p>
<p>Detector</p>	<p>These are the alarms for each of the detectors. Click on the required field to change the value (note that the selected detector is highlighted in the pictorial view). <i>Note that the High and/or Cobalt columns are displayed if Enable High Level Alarm and/or Enable Cobalt-60 Windows Alarm is ticked - see Options 3 (page 5-12).</i></p>

<p>2-Detector Sum Zone</p>	<p>This field is enabled if Enable 2-Detector Zone Alarms is ticked - see Options 3 (page 5-12).</p> <p>These are the alarms for two side-by-side detectors. Click on the required field to change the value (note that the selected detectors are highlighted in the pictorial view).</p> <p><i>Note that the High and/or Cobalt columns are displayed if Enable High Level Alarm and/or Enable Cobalt-60 Windows Alarm is ticked - see Options 3 (page 5-12).</i></p>
<p>3-Detector Sum Zone</p>	<p>This field is enabled if Enable 3-Detector Zone Alarms is ticked - see Options 3 (page 5-12).</p> <p>These are the alarms for three side-by-side detectors. Click on the required field to change the value (note that the selected detectors are highlighted in the pictorial view).</p> <p><i>Note that the High and/or Cobalt columns are displayed if Enable High Level Alarm and/or Enable Cobalt-60 Windows Alarm is ticked - see Options 3 (page 5-12).</i></p>

Battery

Select Set-Up|Battery to configure the Battery Charger

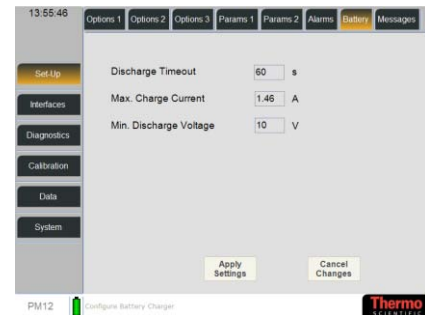

Note that this section is set by at production and should only be changed in consultation with Thermo Fisher Scientific.

Description of options:

Field Name	Description
<p>Discharge Timeout (Secs)</p>	<p>This is the amount of time after the battery discharges to the minimum discharge voltage before the charger turns off the output power.</p> <p>If the charger is already running on battery power, the value of the timeout will not e changed</p> <p>The timer can only be stopped if the mains power is returned</p>
<p>Max. Charge Current (A)</p>	<p>This is the maximum current allowed for charging the battery. The charge current is monitored constantly and the PSU output voltage is reduced if this current is exceeded.</p>
<p>Min. Discharge Volume (V)</p>	<p>This is the voltage at which the timer starts, when the battery is being discharged.</p>

Messages It is possible to amend the Headline(s) and Instructions for the following messages:

- Normal Alarm
- High Level Alarm
- Clear
- Co60 Alarm

Select Set-Up|Messages to select a message to configure:



Use the direction arrow to find a Message to configure. Once selected, the text can be updated by pressing on the Headline, Headline 2 and Instruction fields. To save the changes, press Apply Settings button.

To set the selected message back to its default setting, press the Set Default button.

Available Messages:

Message	Headlines and Instructions
Normal Alarm	ALARM – Contamination Present – Please call HP
High Level Alarm	HIGH ALARM LEVEL - Contamination Present – Please call HP
Clear	CLEAR – OK to Leave Portal
Co60 Alarm	Co60 ALARM – Contamination Present – Please call HP

Interfaces

Plug-ins

Select Interfaces|Plug-ins to configure an interface to another system:

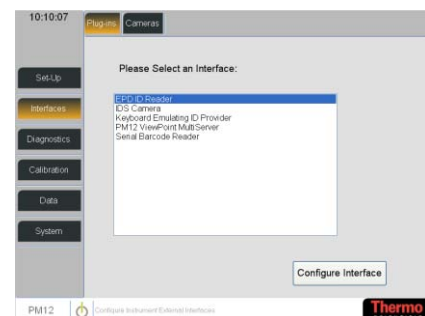

Note that interfaces are not limited to the examples given below. Other interfaces are possible and the parameters described below may vary according to the interface selected. Please contact Thermo Fisher Scientific regarding your specific interface requirements.

- EPD Id Reader – see [EPD Id Reader \(page 5-23\)](#)
- IDS Camera – see [IDS Camera \(page 5-23\)](#)
- Keyboard Emulating Id Provider – see [Keyboard Emulating Id Provider \(page 5-24\)](#)
- ViewPoint MultiServer – see [PM12 ViewPoint MultiServer \(page 5-25\)](#)
- Serial Barcode Reader – see [Serial Barcode Reader \(page 5-27\)](#)

For further information in setting up any of these Plug-ins, please contact Thermo Fisher Scientific.

To configure an Interface

Highlight the Interface to configure and select the Configure Interface button:

Note that the selected type of interface is displayed in the top left hand corner.

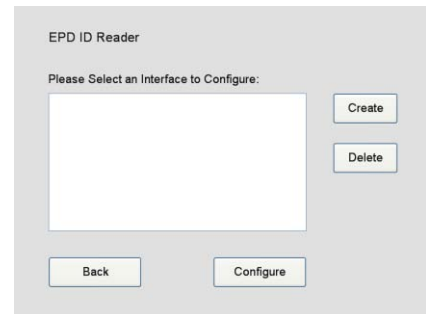

The Create button allows the user to Create a new Interface.

The user is prompted to enter a name for the new Interface.

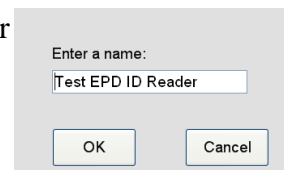

To delete an existing interface, highlight the Interface and press the Delete button. Select OK to continue.

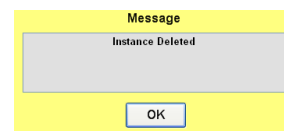

The Configure button allows the user to configure an existing highlighted interface.

The Back button returns the user to the previous screen.

EPD Id Reader Press the OK button to display the editable parameters for the EPD Id Reader:

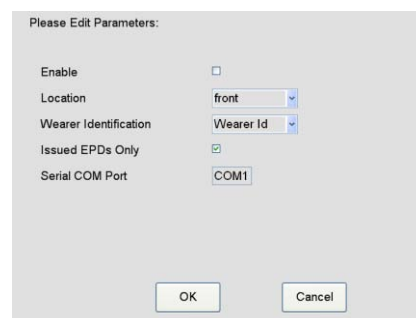

Description of options:

Field Name	Description
Enable	Tick this option to enable the interface to work with the PM12.
Location	Use the drop-down button to select either front, rear or either.
Wearer Identification	Use the drop-down button to select either Wearer Id or Wearer Name as Wearer Identification.
Issued EPDs Only	Tick this box if the reader is to detect Issued EPDs only.
Serial Port	This is the COM Port for connection to the interface.

IDS Camera Press the OK button to display the editable parameters for the IDS Camera:

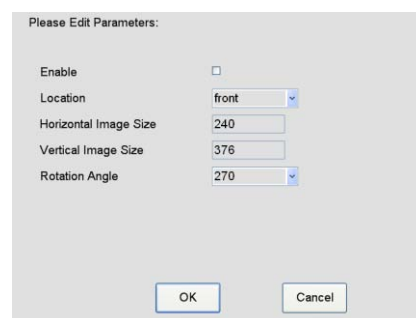

Description of options:

Field Name	Description
Enable	Tick this option to enable the interface to work with the PM12.
Location	Use the drop-down button to select either front or rear.
Horizontal Image Size	Enter the horizontal image size (in mm).
Vertical Image Size	Enter the vertical image size (in mm).
Rotation Angle	Use the drop-down button to select either 0, 90, 180 or 270.

Keyboard Emulating Id Provider

Note that a Keyboard Emulating Id Provider is the terminology used for a USB Barcode Reader.

Press the OK button to display the editable parameters for the Keyboard Emulating Id Provider:

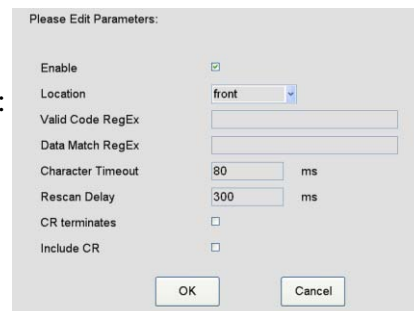

Description of options:

Field Name	Description
Enable	Tick this option to enable the interface to work with the PM12.
Location	Use the drop-down button to select either front or rear.
Valid Code RegEx Data Match RegEx	These fields permit validation of a barcode and extraction of portions of data within the barcode for the Stream ID. If left blank, no validation is performed and any barcode is valid. See Notes regarding Regular Expressions for Barcode (page 5-25) for further information.
Character Timeout (ms)	This is the period during which the scanner can receive barcode data. If the barcode is not detected during this time, it resets. Default: 100 milliseconds
Rescan Delay (ms)	Once a barcode has been read, this is the period before a subsequent barcode can be read. Default: 500 milliseconds
CR terminates	If a Carriage Return is to indicate the end of the barcode, tick this box. Default: Ticked
Include CR	If a Carriage Return is to be included within the barcode, tick this box. Default: Unticked

Notes regarding Regular Expressions for Barcode

Here are a few common regular expressions which may be used for any of the IDs above:

Start of line string	^
End of line string	\$
Whitespace character	\s
Word character	\w
Digit character	\d

Note that you can specify the type of characters as follows:

[0-9] is numbers only

[a-z] is any lowercase ASCII letters

[A-Z] is any uppercase ASCII letters

[0-9A-Z] is alpha-numerical (note the space following the A-Z)

{x,y} where x is the minimum number of characters and y is the maximum number of characters e.g. {4,10} would read a minimum of 4 up to a maximum of 10, {4} would read exactly 4 characters and {4,} would read a minimum of 4 with no maximum

Named capture group (?<name>...)

Examples:

User ID	<code>^U(?<id>[0-9A-Z]{4,})</code>
Numbers from 0 to 999999	<code>^\d{1,6}\$</code> e.g. 123, 123456
US Social Security number	<code>^\d{3}-\d{2}-\d{4}\$</code> e.g. 123-12-1234

For further information on setting up valid barcode expressions, contact Thermo Fisher Scientific.

PM12 ViewPoint MultiServer

Press the Configure Interface button to display the editable parameters for the PM12 ViewPoint MultiServer:

Description of options:

Field Name	Description
Enable	Tick this option to enable the interface to work with the PM12.
Instrument ID	Enter a name for the Instrument.
Report Interval	Enter a period (in seconds) that ViewPoint is contacted.
Primary Interface Enable	Tick this box to enable the Primary Interface to ViewPoint.
Primary IP Address	Enter IP Address for the Primary Interface
Primary TCP Port	Enter the TCP Port for the Primary Interface
Secondary Interface Mode	Use the pre-defined window to select an option from one of the following: Disabled – to disable the Secondary Interface Fallback – to enable the Secondary Interface ONLY if the Primary Interface is disabled Enabled – to enable the Secondary Interface Default: Disabled
Secondary IP Address	Enter IP Address for the Secondary Interface
Secondary TCP Port	Enter the TCP Port for the Secondary Interface
Serial Interface Mode	Use the pre-defined window to select an option from one of the following: Disabled – to disable the Serial Interface Fallback – to enable the Serial Interface ONLY if the Primary/Secondary Interface is disabled Enabled – to enable the Serial Interface Default: Disabled
Serial COM Port	This is the COM Port for connection to the interface.
Serial Baud Rate	Use the pre-defined window to select Baud Rate from one of the following: 9600 19200 38400 115200 Default: 38400
Fallback Recovery Interval (s)	Enter a Fallback period which will trigger the Fallback interface if the main interface fails. Default: 60 seconds

Serial Barcode Reader

Press the OK button to display the editable parameters for the Serial Barcode Reader:

Description of options:

Field Name	Description
Enable	Tick this option to enable the interface to work with the PM12.
Location	Use the drop-down button to select either front or rear.
Valid Code RegEx Data Match RegEx	These fields permit validation of a barcode and extraction of portions of data within the barcode for the Stream ID. If left blank, no validation is performed and any barcode is valid. See Notes regarding Regular Expressions for Barcode (page 5-25) for further information.
Character Timeout (ms)	This is the period during which the scanner can receive barcode data. If the barcode is not detected during this time, it resets. Default: 100 milliseconds
Rescan Delay (ms)	Once a barcode has been read, this is the period before a subsequent barcode can be read. Default: 500 milliseconds
CR terminates	If a Carriage Return is to indicate the end of the barcode, tick this box. Default: Ticked
Include CR	If a Carriage Return is to be included within the barcode, tick this box. Default: Unticked

Cameras

Note that this option is only available if camera(s) have been installed (see IDS Camera (page 5-23)).

The current image is displayed on screen.



To adjust the Brightness, move the orange bar to decrease the brightness and to the right to increase the brightness.

To adjust the Contrast, move the orange bar to decrease the contrast and to the right to increase the contrast. Tick the Auto button for automatic adjustment of the contrast.

To adjust the Gain, move the orange bar to decrease the gain and to the right to increase the gain. Tick the Auto button to automatically control the gain of a signal.

Diagnostics Menu

Detector Bar

Select Diagnostics|Detectors Bar to view the Detectors information



The Detectors are updated every measurement cycle.

Note that the Background Count Rate is averaged and updated over the cycle time selected in the Average Over field.

Description of options:

Field Name	Description
Average Over (samples)	Enter the number of samples from which the average is calculated for display.

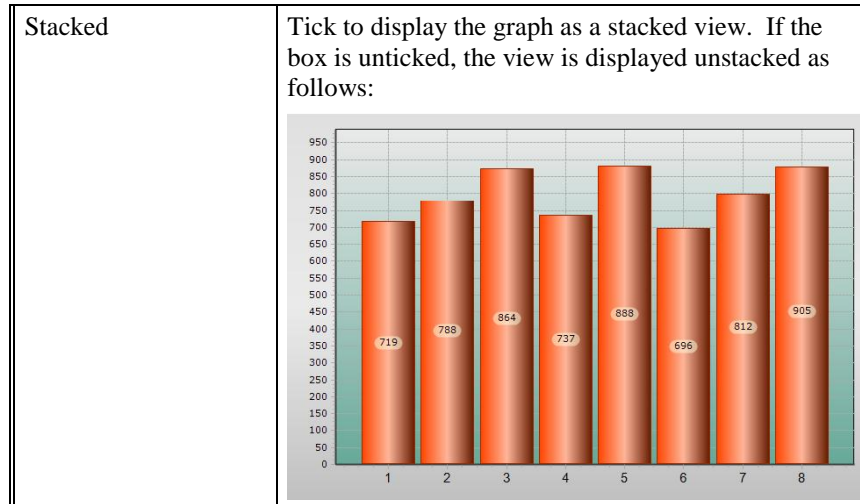

Information Select Diagnostics|Information to view the current Measurement Information

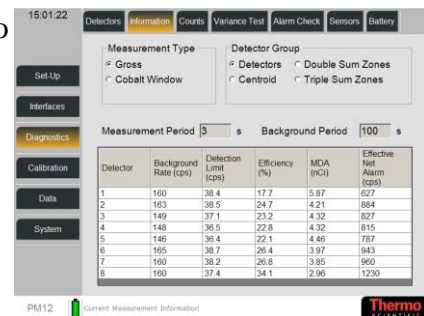

Description of options:

Field Name	Description
Measurement Type	<p>Click on one of the radio buttons to select one of the following:</p> <ul style="list-style-type: none"> Gross – displays the Gross count for the select Detector Group (see below). Cobalt Window – displays the Cobalt count for the select Detector Group (see below).
Detector Group	<p>Click on one of the radio buttons to select one of the following:</p> <ul style="list-style-type: none"> Detectors – displays the counts for each individual detector Centroid – displays the counts for the combined detectors Double Sum Zones – displays the counts for adjacent detectors (i.e. 1-3, 3-5, 5-7, 7-8 etc.) Triple Sum Zones – displays the counts for triple adjacent detectors (i.e. 1-3-5, 3-5-7, 5-7-8 etc.)

Measurement Period (s)	<i>Note that this is a view only field.</i> This is the length of time for the sample calculated from the current alarm conditions and background measurement.
Background Period (s)	<i>Note that this is a view only field.</i> This is the current background period. The value is set at 0 if a background has not yet been acquired.

Counts Select Diagnostics|Counts to view Detectors averaged over a selected specified period. This function allows a count to be made which can be used to ascertain the efficiency and functionality of the PM12



To toggle between the individual Detector's Thresholds and the Gross Sum of all Detectors views, press the Detectors|Gross Sum button.

To Start the Timed Counts for the Detectors:

1. Select the number of PM12 to be averaged by selecting a value in the Average Over field.
2. If you require a Continuous count to be made, tick the Continuous box.
3. Press Start button

To toggle between the Thresholds and Windows display, tick the relevant radio button.

Variance Test The variance check is a method by which the overall stability of the background can be assessed by running a sequence of background measurements and then assessing the variance of the measured backgrounds over the sequence.

Select Diagnostics|Variance Test to setup the background monitoring over a number of cycles to obtain a figure of stability

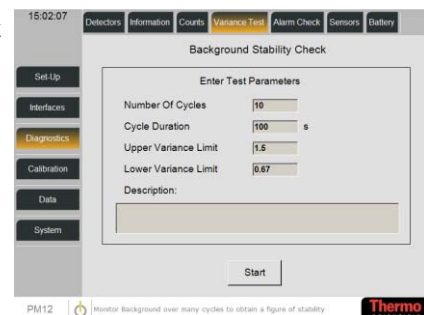

Description of options:

Field Name	Description
Number of Cycles	Enter the number of background measurements to be used in the test.
Cycle Duration (seconds)	Enter the duration of each measurement.
Upper Variance Limit	Enter the Upper Variance Limit for the result. Note that this value should initially be set to 1.5.
Lower Variance Limit	Enter the Lower Variance Limit for the result. Note that this value should initially be set to 0.67.
Description	Enter a description of the test.

Once the options have been set, press Start for the Background Stability Check to run. A progress window is displayed:

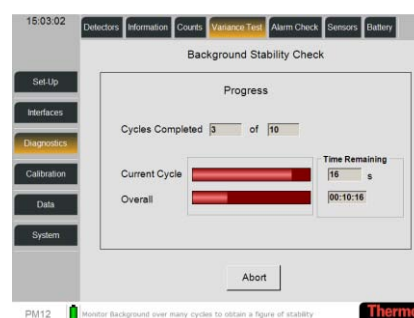

Press Abort button to abandon the check. If the check is left to run, the results are displayed as follows:

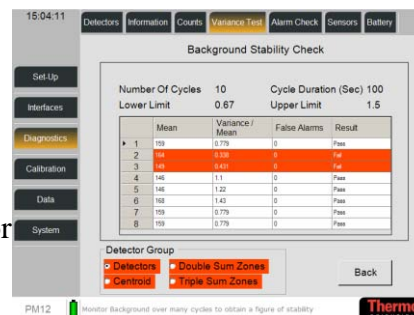

Select one of the Detector Group options to highlight the results for the relevant group.

Note that the Double Sum Zones option is enabled if Enable 2-Detector Zone Alarms is ticked and the Triple Sum Zones option is enabled if Enable 3-Detector Zone Alarms is ticked - see [Options 3 \(page 5-12\)](#).

Press Back button to return to the Test Parameters window.

Alarm Check Select Diagnostics|Alarm Check to check the Alarms against a known source:

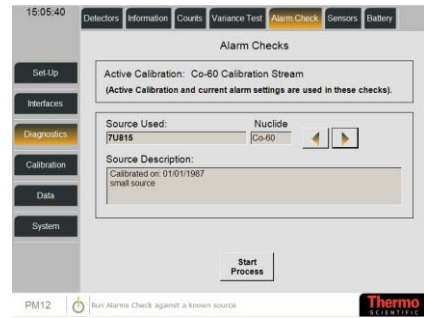

Ensure that a Background Measurement has been run, otherwise, the following message is displayed:

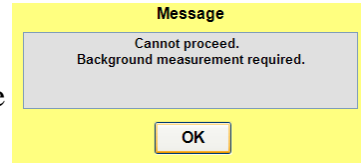

Use the direction arrows to select a Source. Once selected, press the Start Process button:

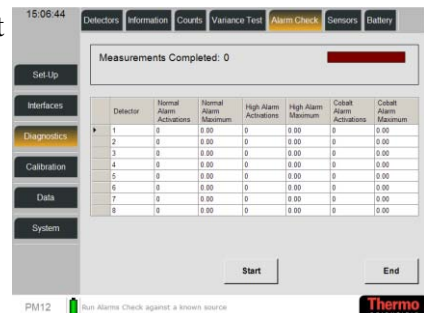

Press the Start button to commence the Alarm test:

Note that any alarms are indicated in red on screen.

The Pause button can be selected at any time to interrupt the measurements. To recommence the test, select the Start button again.

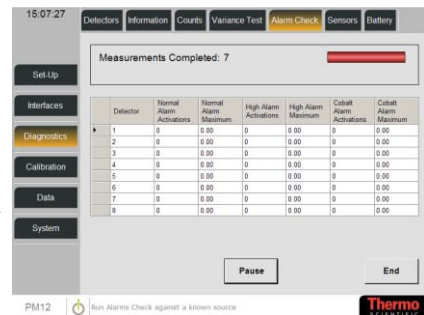

To complete the test, select the End button. The Save, Continue and Abort buttons are now displayed. To enable the user to save the results, to continue with the test or abort the test and return to the Alarms screen.

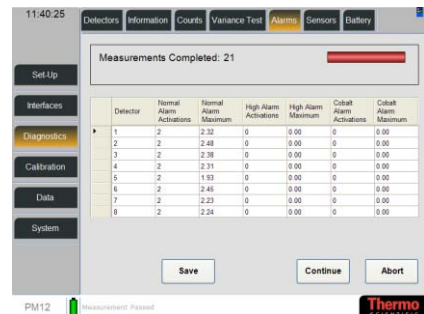

To view the saved results, see [AlarmCheck Report \(page 5-49\)](#).

Sensors Select Diagnostics|Sensor to check the sensors and visual elements.

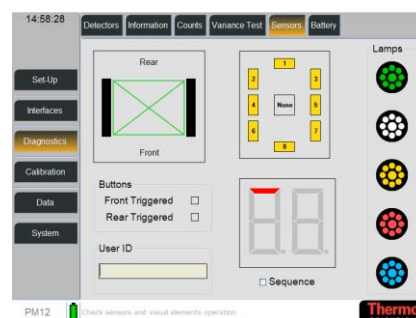

Select the Sequence tickbox to test the Detector, LED and Lamps display.

To test Portal Sensors, the display will indicate with a red line, where the sensor's line is broken, as follows:

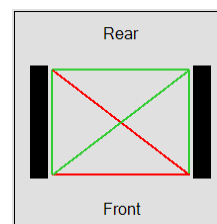

To test Buttons, the display will indicate with a green box, when the front and/or rear button is pressed, as follows:

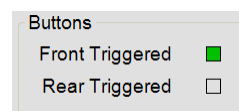

To test User ID, select the User ID input box and enter an ID, as follows:

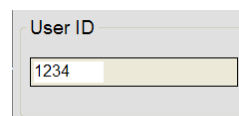

To test the Detectors, press the corresponding number in the graphic:

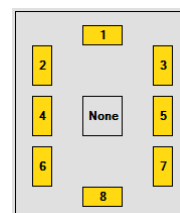

To test the LED, tick the Sequence tickbox. Each segment of the LED will turn red sequentially.

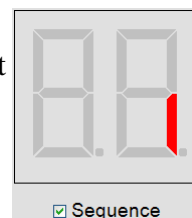

Note that the Detectors and Lamps will also light up sequentially.

To test the Lamps, press the lamp icon which will light up.



Barriers Select Diagnostics|Barriers to check the installed barriers:



To test the opening/closing of the barriers, tick the Open/Close buttons. The display will indicate with a green box, if the barrier has opened/closed or is in Transit or whether the barrier is Blocked/Faulty, as follows:



Battery Select Diagnostics|Battery to view the current status of the battery charger:



When the mains power is ON, the system charges the battery.
 When no mains power is present, the system operates from the battery.

Calibration Menu Efficiencies

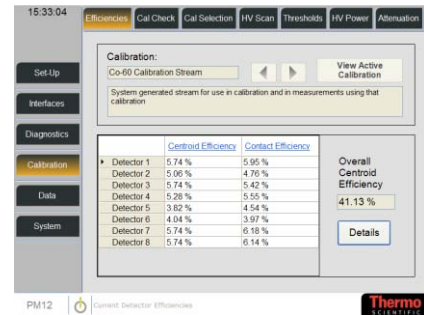

Use the direction arrows to select a Calibration. Once selected, press the Details button to view the Gross Sum Efficiency % for the Detectors.



The View Active Calibration button automatically displays the active Calibration.

Cal Check

This option allows the user to edit existing Calibration sources and create new ones. There are also functions available to allow the user to check or overwrite the current calibration factor.

Select Calibration|Cal Check to edit the Calibration setting against a selected source and to conduct a calibration check.

The Decay Corrected Activity is displayed on this screen.

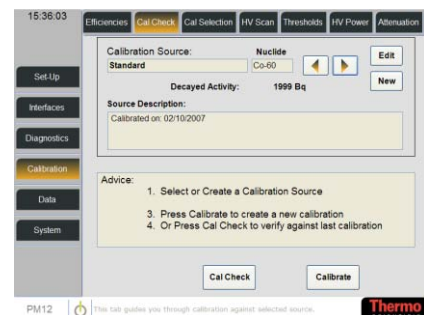

Note that the Calibrate button is not available to the Technician role.

To edit Calibration Source properties, use the direction arrows to select a Calibration Source. Once selected, press Edit button to display the Edit Source properties window:



Description of options:

Field Name	Description
Nuclide	This option is only available when creating a new Calibration Source (see below). This changes the displayed activity units for the PM12.
Source Name	Enter a Source name.
Last Calibration Date	Select a Calibration Date from the date picker.
Activity	Enter an Activity value. Use the pre-defined window to select a unit from one of the following: <ul style="list-style-type: none"> • μCi • Bq • Ci • dpm • nCi • pCi
Comment	Enter a Comment to describe the Source, if required.

To create a new Calibration Source, press New button to display the Select a Nuclide and complete all fields below window.

Select a pre-defined option from the list provided and enter the required options (see above for Description of options). Select Apply Settings button to create the new Calibration Source or Cancel Changes button to quit without saving.

All calibration results are logged to the database. The "Calibrate" function allows users to overwrite the Calibration factor. The "Cal Check" function informs the user of any discrepancy with the current calibration factor.

To Check the PM Calibration, select a Calibration Source. Then press Calibrate button to display the Calibration requirements page.

Select a Source Position (either Centroid or Contact) and then select the Detectors to include in the Calibration Check.

Select a Calibration Accuracy and Calibration Confidence.

The Calibration Accuracy, along with the background measurement, determines the count time required when the PM12 is being calibrated.

Remove all items from the Portal vicinity and press the Start button.

Note that the Abort button can be pressed at any time during the process to return to the previous window.

The PM12 does a one second background measurement which is used in conjunction with the Calibration Accuracy value when calculating the time required for the source count.

When the Background Measurement is complete, place the source in the PM12 (as instructed according to the Source Position selected above) and press Start.

The PM12 performs a Flash Measurement to calculate the Calibration time.

Note that the Calibration time is the sum of the Background and Source measurements. The minimum time is 20 seconds.

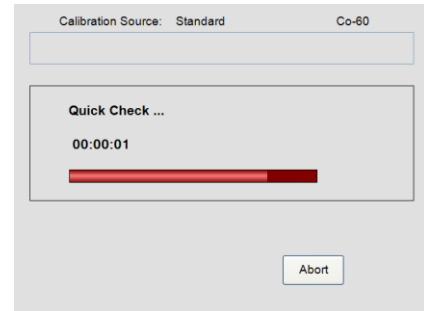

When the Flash Measurements are complete and the Calibration time is displayed, press the Start button.

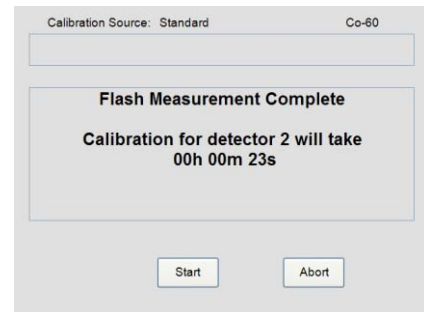

The calculated count time decrements while the source is measured.

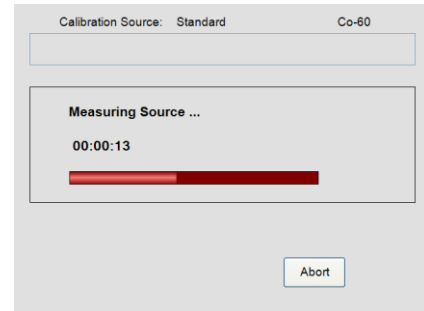

If multiple detectors have been selected as Source Position above, the user is requested to move the source and repeat the Measurement.

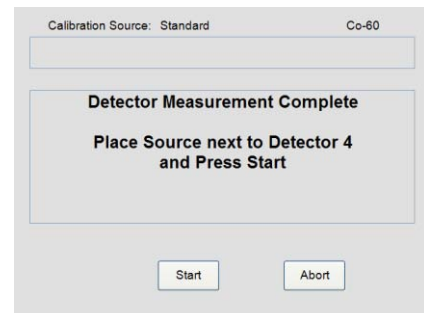

When the Source Measurement has been completed, remove the Source and press the Start button for the final background measurement.

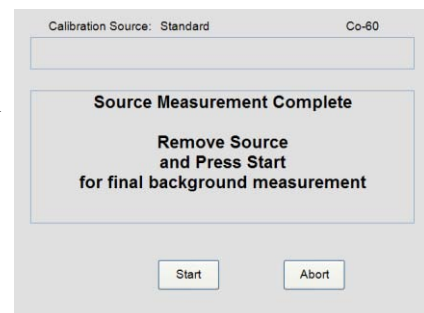

The PM12 measures the background and the calculated count time decrements

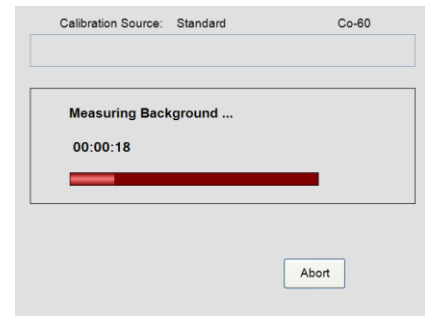

If the calculated efficiency has an illegal value (i.e. no net counts), the efficiency will be set to zero.

If a result is calculated, the new calibration data is displayed.

Note that during a Cal Check only an OK button is displayed which returns to the Calibration/Cal Check screen.

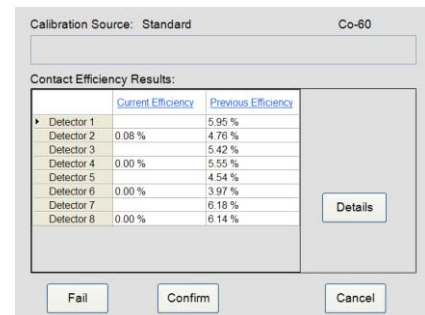

Note that the Cancel button will abandon the process.

Press the details button to reveal the detailed results.

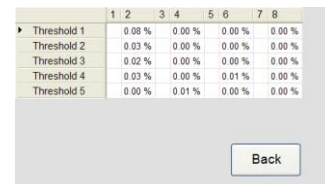

If you are satisfied with the result, press the Confirm button to display the Add Description for the Calibration page. Select OK to complete the process.

Note that the results are stored in the database and marked as PASS.

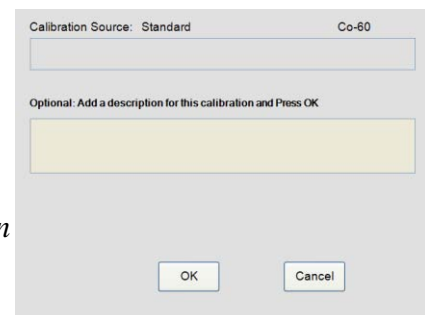

If you are NOT satisfied with the result, press the Fail button. The Calibration Source page is re-displayed.

Note that the results are stored in the database and marked as FAIL.

To check the current Calibration, select a Calibration Source. Then press Cal Check button to display the Ready to Start window.

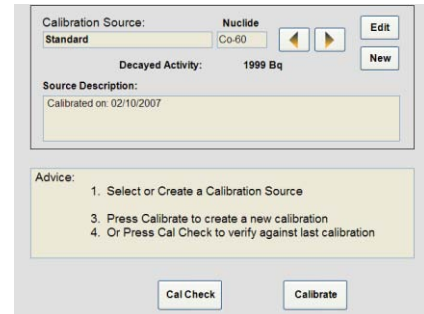

Select the required Source Position and Detectors to include in the Calibration. Select the Calibration Accuracy and Confidence.

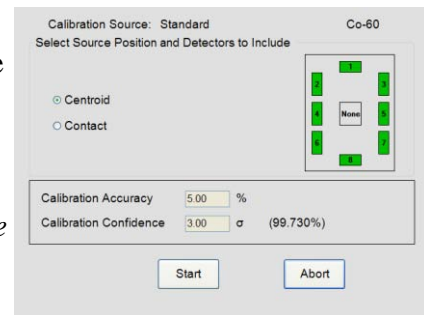

Note that the Abort button can be pressed at any time during the process to return to the previous window.

When the Start button is pressed, the process is similar to that described above in [To Check the PM Calibration \(page 5-37\)](#).

Description of Error messages:

Error Message	Resolution
Unable to calculate a valid monitoring time	1. There is no source available 2. The source does not have enough activity 3. If a cobalt calibration has been activated and the source is not cobalt60
This is not the default Calibration Source	This is a warning message only

Calibration Selection

Select Calibration|Calibration Selection to view current Calibration and create new customised Calibration



Note that the Active Calibration with its Gross Sum Efficiency % is displayed in the top box.

To change the Active Calibration, use the direction arrows to select a Calibration. Once selected, press Make Active button. The selected Calibration and its Gross Sum Efficiency will be displayed in the top box.

To edit a Calibration Mix, select a Calibration. Press in the Calibration field to edit the Calibration name. In the Calibration Mix section, use the drop-down list to change the Nuclide. Press in the Percentage field to edit the percentage. When complete, press Apply Settings button to save or Cancel button to quit without saving.

To create a new Calibration Mix, highlight in an empty Calibration Mix window (or an existing Calibration Mix to overwrite) and click on the Create New Mix button. Press in the Calibration field to create a new Calibration name. In the Calibration Mix section, use the drop-down list to add a new Nuclide. Press in the Percentage field to edit the percentage. When complete, press Apply Settings button to save or Cancel button to quit without saving.

To delete an existing Calibration Mix, highlight the Calibration Mix for deletion and press the Delete Mix button.

HV Scan

Select Calibration|HV Scan to view and create HV Scans. It is also possible to set HVs for detector amplifiers. The scan allows repeated counts at an increasing or decreasing HV to be recorded to ascertain detector operating point and efficiency

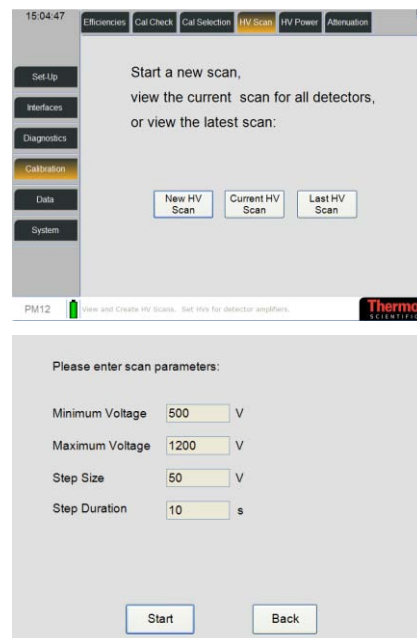

To start a new HV Scan, press the New HV Scan button to display the Please enter scan Parameters window:

Description of options:

Field Name	Description
Minimum Voltage (V)	Enter a minimum voltage.
Maximum Voltage (V)	Enter a maximum voltage. <i>Note that this value should at least be Minimum Voltage + Step Size.</i>
Step Size (V)	Enter a step size for the scan.
Step Duration (s)	Enter the length (in seconds) for each step.

Once the above scan parameters have been established, two scans will be made against each amplifier threshold for all amplifiers at each HV step over the specified integration period:

- A background HV Scan
- A source HV Scan

When the options have been entered, press Continue button to display Ready to Start Background Scan window:

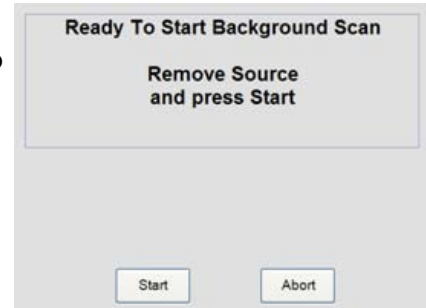

Remove any current Source from the PM12 and press the Start button. A background HV scan will be performed, recording the counts against **each amplifier threshold** for all amplifiers at each HV step over the specified integration period. A progress window is displayed:



Once the Background Scan is completed, the Select Detectors for Scan screen is displayed:

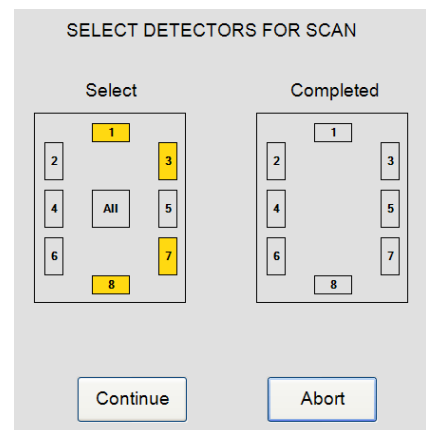

Highlight the required Detectors and press Continue. The Ready to Start Scan of Source is displayed:

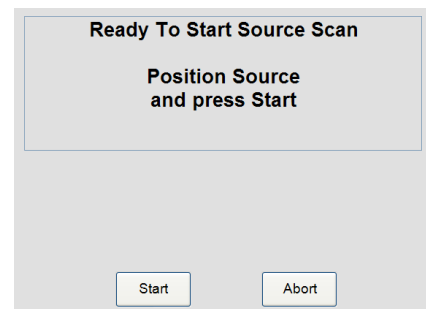

Position the Source to be scanned in the PM12 and press the Start button. A source HV scan will be performed, recording the counts against **each amplifier threshold** for all amplifiers at each HV step over the specified integration period. A progress window is displayed:



On completion of the scan, a More Detectors and Complete button are displayed:

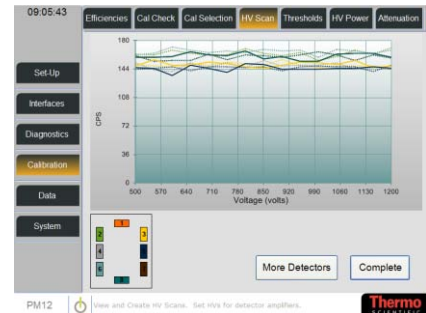

The More Detectors button returns the user to the Select Detectors for Scan window indicating which Detectors have already been scanned and giving the option to add further Detectors for scan.

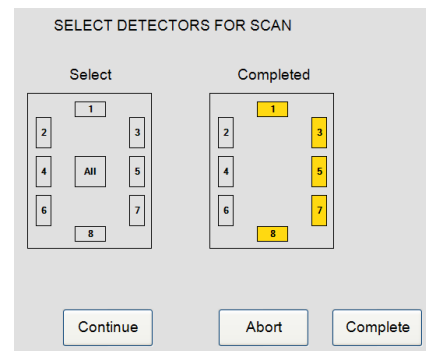

Once the Scan is completed (and the Complete button has been pressed), a Save Scan window appears giving the option to save the scan or Abort the process.

To Save the Scan, press Save to display the Please enter a scan description window:

Enter a Scan Description and press Save button to display the Scan results:



Select Apply button to save the Scan.

Press Cancel button to quit without saving or press Back button to return to the Start new scan screen.

To view the HV Scan as a Table, press the Table button to display the scan results:

	1	3	5	6	7	9
500	2	2	2	6	2	2
550	5	8	0	2	5	5
600	5	2	11	12	5	5
650	11	2	7	1	11	11
700	1	4	2	2	-1	-1
750	5	2	7	3	5	5
800	5	4	5	4	5	5
850	4	4	3	7	4	4
900	1	7	2	6	1	1
950	8	4	3	4	8	8
1000	-12	8	-4	10	-12	-12
1050	1	2	-2	3	1	1
1100	9	7	2	3	9	9
1150	2	2	6	6	2	2

To view the HV Scan as a Graph, press the Graph button to display the scan results:



To view the current Scan for all detectors, press the Current HV Scan button to display the scan results:



To view the last saved HV Scan, press the Last HV Scan button to display the scan results:



See [Performing the HV Scan \(page 9-4\)](#) for more information regard the HV Scan.

Thresholds Select Calibration|Thresholds to set the Detector Thresholds:

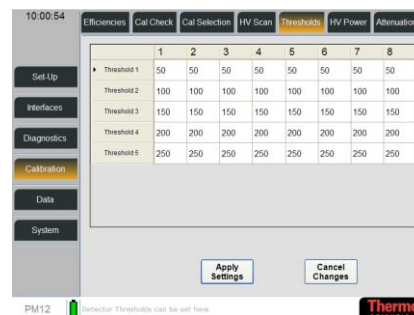

This screen allows the individual voltage of any detector to be viewed and updated.

To change any of the settings, press in the field and update the value. Press Apply Settings button to save or Cancel Changes button to quit without saving.

Note that no threshold value should be set to a voltage that is less than that of the preceding threshold. For example, Threshold 5 must be set greater than or equal to Threshold 4. Failure to follow this advice may invalidate measurements. Please contact Thermo Fisher Scientific before changing threshold values.

HV Power Select Calibration|HV Power to view the Amplifier Power Settings



This screen allows the lower and upper limits for the HV Power to be viewed and updated. It measure the current being delivered to the HV Generator (see [Setting the FHT681 Current Limits \(page 11-12\)](#) for further information).

Attenuation Select Calibration|Attenuation to set a sequence to obtain Attenuation Factors (note that a Phantom object or person is required for this process):

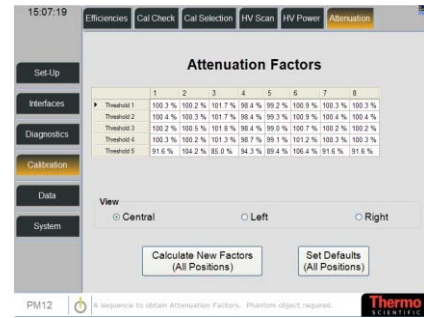

To Calculate New Factors, press Calculate new Factors button to display the Ready to Start window:

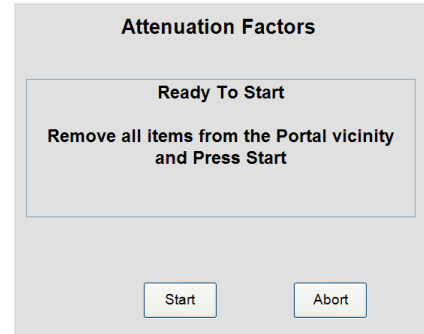

Remove all items from the PM12 vicinity and press the Start button to commence measuring the empty Portal.

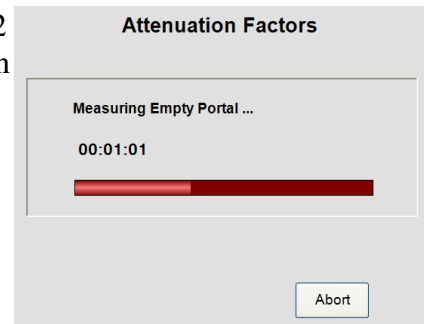

The PM12 measures the Empty Portal and the calculated count time decrements.

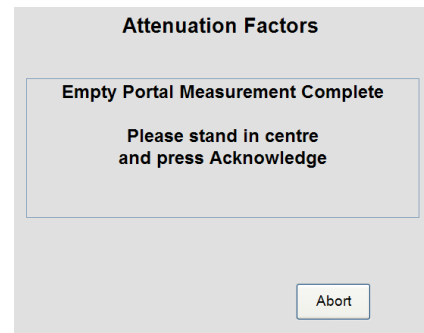

The progress window is displayed until the Empty Portal Measurement Complete window is displayed. Stand in the centre of the portal and press the Acknowledge button to commence measuring the portal with a person present.

A progress window is displayed until the Centre Measurement is complete:

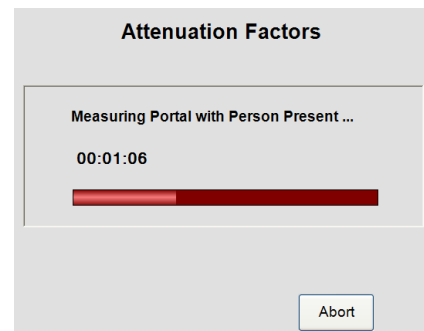

Move to the Left Wall and press the Acknowledge button to continue measuring the portal with a person present:

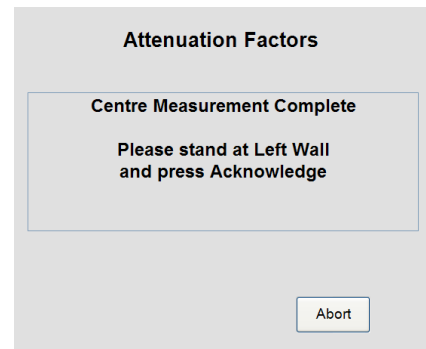

A progress window is displayed until the Left side Measurement is complete:

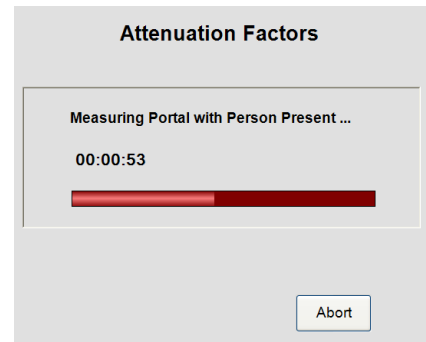

Move to the Right Wall and press the Acknowledge button to continue measuring the portal with a person present:



A progress window is displayed until the Right side Measurement is complete:

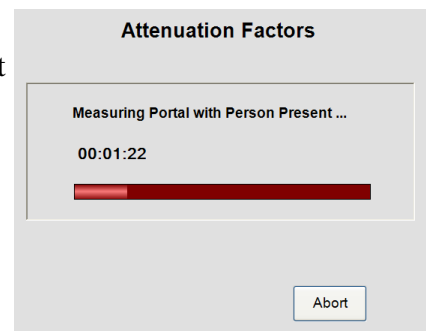

When the measurements are complete, the Attenuation Factors are displayed. Option to view the Central, Left and Right results is available.

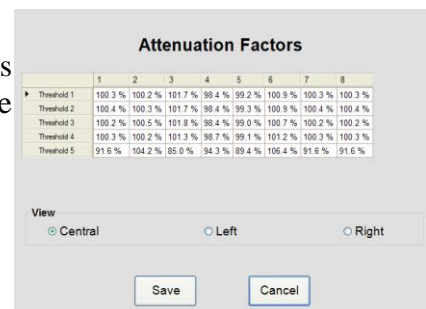

To Save the Attenuation Factors, press the Save button.

If the Attenuation Factors are invalid, the following error message is displayed and it is not possible to save the factors:

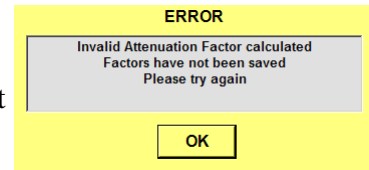

An error is displayed if the person does not move to the correct position in the portal when instructed:

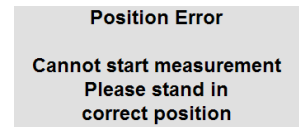

To set Default Attenuation Factors for all positions, press the Set Defaults button:

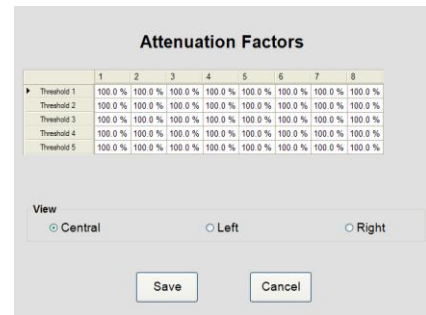

Data Menu

Reports

Select Data|Reports to select a Database Report from a pre-defined list:

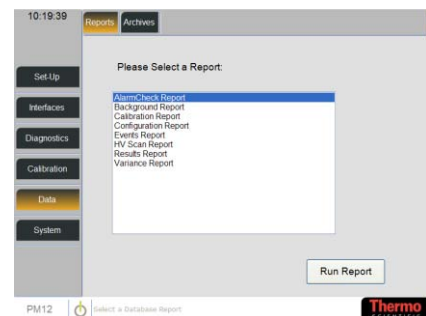

To run a report, select one from the list and press the Run Report button. The types of Reports available are listed below. Each report can be limited by various parameters, e.g.



Each report displays the following button bar

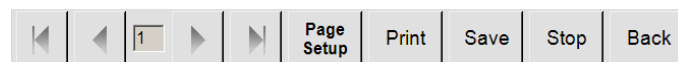

Report Button Functions



Direction Arrows steps through the report pages



Page Setup display the Report Page settings:

Report Page Settings:

Paper Size	A4 (210 x 297 mm)
Paper Orientation	Portrait
Left Margin (in.)	0.50
Right Margin (in.)	0.50
Top Margin (in.)	1.00
Bottom Margin (in.)	1.00

Enter the required settings and press OK



The Print button sends the report to the printer.



The Save button displays the Drive selection window to allow you to select a Drive for the saved report. The report will be saved as an Excel spreadsheet with the following name:

<Report Type><YYMMDDHHMM>.xls

e.g.

ResultsSummary0612031151.xls



Stop cancels the processing of the report.



Back returns the user to the previous screen.

AlarmCheck Report

This report shows the Alarm Check Summary information between the selected Start and End Dates. It is possible to limit the report by Start and End Date.

Alarm Check Summary

ID	Test Start Time	Source Name	Measurement Count
1	04/10/2007 11:35:31	Standard	21

Press on one of the ID records to display the Background Measurement Detail for the selected Measurement ID:

Background Variance Test Results Detail

Test Date: 04/10/2007 11:35:31

Detector	Normal Alarms	Normal Alarm Multiplier	High Alarms	High Alarm Multiplier	Cobalt Alarms	Cobalt Alarm Multiplier
1	2	2.32	0	0.00	0	0.00
2	2	2.48	0	0.00	0	0.00
3	2	2.38	0	0.00	0	0.00
4	2	2.31	0	0.00	0	0.00
5	2	1.93	0	0.00	0	0.00
6	2	2.45	0	0.00	0	0.00
7	2	2.23	0	0.00	0	0.00
8	2	2.24	0	0.00	0	0.00

Background Report This report shows the Background Rate Trend between the selected Start and End Dates. It is possible to limit the report by Start and End Date.

Please note that the report below is an example and does not display all the information.

Background Measurement Summary

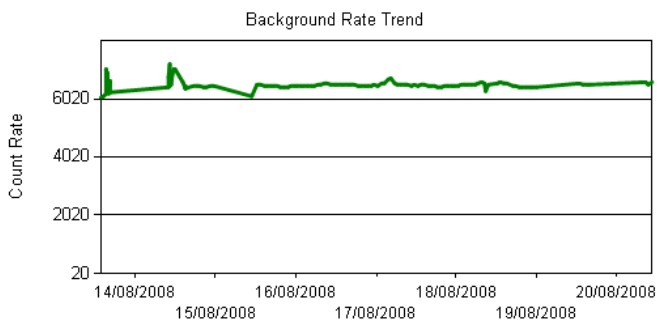

ID	Measurement Date	Count Rate	Changing	Integration Period
126	20/08/2008 10:29	6555	Yes	10
125	20/08/2008 09:23	6469	Yes	10
124	20/08/2008 08:41	6564	Yes	10
123	19/08/2008 16:02	6471	No	100
122	19/08/2008 15:05	6469	Yes	10
121	19/08/2008 13:56	6489	No	100
120	19/08/2008 12:56	6527	Yes	10
119	18/08/2008 23:54	6395	No	100

Press on one of the ID records to display the Background Measurement Detail for the selected Measurement ID:

Please note that the report below is an example and does not display all the information.

Background Measurement Detail

Background ID: 126

Date/Time: 20/08/2008 10:29

Detector	Threshold	Count Rate (cps)	Integration Period
1	1	727	10
1	2	176	10
1	3	168	10
1	4	74	10
1	5	37	10
2	1	812	10
2	2	147	10
2	3	139	10
2	4	62	10
2	5	24	10
3	1	859	10
3	2	159	10
3	3	155	10
3	4	64	10
3	5	23	10
4	1	738	10
4	2	127	10
4	3	121	10
4	4	44	10
4	5	18	10
5	1	909	10
5	2	164	10
5	3	151	10
5	4	68	10
5	5	25	10
6	1	699	10
6	2	117	10
6	3	110	10
6	4	39	10
6	5	19	10
7	1	858	10
7	2	141	10
7	3	133	10
7	4	53	10
7	5	20	10
8	1	953	10
8	2	170	10
8	3	160	10
8	4	72	10
8	5	35	10

Calibration Report This report lists Calibration History for the PM12. It is possible to limit the report by Start and End Date, and Full Cal.

Calibration History

ID	Calibration Date	Type	Nuclide	Source	Centroid Efficiency (%)	Pass/Fail	Comments
3	04/10/2007 15:51:47	Contact	Co-60	Standard		Pass	
2	02/10/2007 11:20:58	Contact	Co-60	Standard		Pass	first cal
1	02/10/2007 11:19:00	Centroid	Co-60	Standard	41.13	Pass	first cal

Press on one of the ID records to display the Calibration Efficiencies for the selected Calibration ID:

Calibration Efficiencies

Calibration ID: 3 Calibration Date: 04/10/2007 15:51:47
 Confidence: 3.00
 Accuracy: 5.00 % **Full Calibration**

Detector	Threshold	Activity Efficiency (%)
2	Contact	
	1	0.08
	2	0.03
	3	0.02
	4	0.03
4	Contact	
	1	0.00
	2	0.00
	3	0.00
	4	0.00
6	Contact	
	1	0.00
	2	0.00
	3	0.00
	4	0.01
8	Contact	
	1	0.00
	2	0.00
	3	0.00
	4	0.00
	5	0.00

Configuration Report

This report lists the current Instrument Configuration settings.

Please note that the report below is an example and does not display all the information.

Configuration Settings on 20 August 2008

Instrument: PM-003

Configuration Item	Value
Alarm Requires Supervisor Acknowledge	Yes
Portal Approach Time (s)	2
Auto Recount on Alarm Enabled	No
Background Logging Interval (hours)	1
Cal Check Required Interval (days)	0
Default Calibration Accuracy (%)	3
Default Calibration Confidence (%)	2
Camera Fitted	Yes
Gross Changing Background Sigma	3
Changing Conditions Sigma	4
Detector Changing Background Sigma	5
Changing Conditions Check Period	2
Co60 Alarms Enabled	No
Complete All Steps	No
Background Data Retention (months)	12
Calibration Check Data Retention (months)	3
Calibration Data Retention (months)	24
Event Log Data Retention (months)	6
Results Data Retention (months)	6
Default Calibration Source	KU758
Probability of False Alarm	3.1
Probability of Detection	1.65
Dual Zone Alarms Enabled	No
Exit Direction Restricted	Yes
Exit Violation Duration (s)	15
Alarm Duration After Exit (s)	7
High Background Limit (cps)	10000
High Level Alarms Enabled	No
ID Timeout (s)	10
Instrument Contaminated	No
Language	en-GB
Location	Beenham engineering
Low Background Limit (cps)	30
Low Energy Ratio Threshold	100
Manual Recount Enabled	No
Max Clear Display Time	5
Maximum Monitoring Time (s)	100
Maximum Sensitivity Mode	No
Measurement Confidence Sigma	2
Measurement Cycle Mode	Single Step
Measurement Start Timeout (s)	10
Minimum Monitoring Time (s)	3

Page 1 Of 3

Configuration Item	Value
Out of Service Auto-recovery Interval (mins)	15
Front Barrier Enabled	Yes
Rear Barrier Enabled	Yes
Barriers Fitted	Yes
Barrier Exit Delay	1
Ingress Barrier Open for Background	Yes
Ingress Barrier Open for Measurement	Yes
Ingress Barrier Open when Ready	Yes
Portal Entry Side	Rear
Portal Unidirectional	Yes
Quick Scan Check Period	4
Quick Scan Enabled	Yes
Residual Contamination Check After Alarm	No
Residual Contamination Check Sigma	7
Save User Image	Always
Active Calibration Identifier	CAL_Cs-137
Default Units	nCi
Show Activity on Clean Result	Yes
Show Activity on Alarm	Yes
Show Low Energy On Result	Yes
Show Uncertainty Value on Result	Yes
Triple Zone Alarms Enabled	No
Use Quick Background	Yes
User Can Cancel Alarm	Yes
User ID Required	No
User Message Normal Alarm 1	NotAssigned
User Message Normal Alarm 2	NotAssigned
User Message Normal Alarm 3	NotAssigned
User Message Clear 1	NotAssigned
User Message Clear 2	NotAssigned
User Message Clear 3	NotAssigned
User Message Co60 Alarm 1	NotAssigned
User Message Co60 Alarm 2	NotAssigned
User Message Co60 Alarm 3	NotAssigned
User Message High Alarm 1	NotAssigned
User Message High Alarm 2	NotAssigned
User Message High Alarm 3	NotAssigned
User Message High Co60 Alarm 1	NotAssigned
User Message High Co60 Alarm 2	NotAssigned
User Message High Co60 Alarm 3	NotAssigned
Voice Prompts Enabled	Yes

High Voltage levels

Detector	HV level (volts)
1	830
2	844
3	845
4	805
5	895
6	930
7	919
8	896

Detector Threshold levels

Detector	Threshold Number	Threshold Value
1	1	50
1	2	1000
1	3	1050
1	4	1850
1	5	3000
2	1	50
2	2	1000
2	3	1050
2	4	1850
2	5	3000
3	1	50
3	2	1000
3	3	1050
3	4	1850
3	5	3000
4	1	50
4	2	1000
4	3	1050
4	4	1850
4	5	3000
5	1	50
5	2	1000
5	3	1050
5	4	1850
5	5	3000
6	1	50
6	2	1000
6	3	1050
6	4	1850
6	5	3000
7	1	50
7	2	1000
7	3	1050
7	4	1850
7	5	3000
8	1	50
8	2	1000
8	3	1050
8	4	1850
8	5	3000

Events Report This report lists the Event History details between the selected Start and End dates. It is possible to limit the report by Start and End Date.

Please note that the report below is an example and does not display all the information.

Event Time

20/08/2008 09:36:51

20/08/2008 09:25:41

20/08/2008 09:24:50

20/08/2008 09:24:14

20/08/2008 09:23:45

20/08/2008 09:16:48

20/08/2008 08:40:58

20/08/2008 08:40:53

20/08/2008 08:23:30

20/08/2008 08:23:25

Event History

Event Time	Description	Additional Info	Category
05/10/2007 10:11:15	Background Attenuation Factors Changed		Info
05/10/2007 08:55:28	Recovered From Out Of Service		Info
05/10/2007 08:55:08	Out of Service (Recoverable)		Info
05/10/2007 08:45:43	Instrument Starting Up		Info
04/10/2007 15:51:47	New Calibration Saved	Cal Source Id: 1 -	Info
04/10/2007 11:23:44	Instrument Parameters Changed		Info
04/10/2007 11:10:40	Instrument Starting Up		Info
04/10/2007 10:55:54	Instrument Starting Up		Info
02/10/2007 16:38:19	Instrument Shutting Down		Info
02/10/2007 15:56:17	Instrument Parameters Changed		Info
02/10/2007 15:42:06	Instrument Parameters Changed		Info
02/10/2007 15:41:47	Instrument Parameters Changed		Info
02/10/2007 15:26:21	Instrument Parameters Changed		Info
02/10/2007 15:26:11	Instrument Parameters Changed		Info
02/10/2007 15:01:05	Instrument Parameters Changed		Info
02/10/2007 14:36:04	Normal Alarm	Measured Activity 1110 Bq	Alarm
02/10/2007 14:35:34	Instrument Parameters Changed		Info
02/10/2007 14:35:19	Instrument Parameters Changed		Info
02/10/2007 14:33:08	Changing Background		Info
02/10/2007 14:32:14	Instrument Parameters Changed		Info
02/10/2007 14:28:48	Instrument Starting Up		Info
02/10/2007 14:21:03	Program Exit		Info
02/10/2007 14:12:11	Instrument Parameters Changed		Info
02/10/2007 14:12:07	Instrument Parameters Changed		Info
02/10/2007 14:04:29	Changing Background		Info
02/10/2007 14:03:52	Changing Background		Info
02/10/2007 14:02:58	Changing Background		Info
02/10/2007 14:02:32	Instrument Parameters Changed		Info
02/10/2007 13:54:07	Normal Alarm	Measured Activity 2250 Bq	Alarm
02/10/2007 13:53:48	Changing Background		Info
02/10/2007 13:53:42	Instrument Parameters Changed		Info
02/10/2007 13:52:09	Instrument Parameters Changed		Info

HV Scan Report This report lists the HV Scan details between the selected Start and End dates. It is possible to limit the report by Start and End Date.

HV Scan List

ID	Scan Date	Start HV	End HV	Step HV	Step Period (s)	Description
2	13/08/2008 12:32:07	700	1100	20	10	test2
1	13/08/2008 11:55:25	700	1100	20	10	test

Page 1 Of 1

Press on one of the ID records to display the HV Scan Detail for the selected Scan ID:

Please note that the report below is an example and does not display all the information.

HV Scan Detail

Scan ID: 2 **Scan Date:** 13/08/2008 12:32:07

test2

Detector: 2

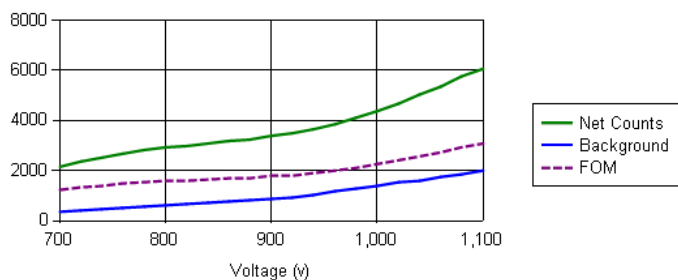

Voltage	Background Counts	Source Counts	Net Counts	Figure Of Merit	T1/T2	T2/T4
700	344	2508	2164	1,215.0	2,164.0	0.0
720	407	2764	2357	1,305.9	1,178.5	2.0
740	458	2970	2512	1,380.0	502.4	-5.0
760	520	3197	2677	1,456.5	892.3	-1.0
780	560	3361	2801	1,517.4	233.4	12.0
800	618	3548	2930	1,574.9	586.0	-0.8
820	670	3656	2986	1,591.1	110.6	13.5
840	720	3801	3081	1,632.6	37.6	82.0
860	751	3944	3193	1,690.5	11.8	30.0
880	813	4047	3234	1,697.5	5.2	69.2
900	861	4223	3362	1,760.6	3.3	32.3
920	932	4388	3456	1,798.6	2.6	21.0
940	1019	4672	3653	1,893.7	2.3	7.8
960	1151	4968	3817	1,962.3	2.1	3.5
980	1265	5388	4123	2,115.9	2.1	2.2
1000	1371	5751	4380	2,243.4	2.1	1.7
1020	1503	6160	4657	2,378.5	2.1	1.5

1040	1582	6620	5038	2,579.7	2.1	1.4
1060	1754	7109	5355	2,731.4	2.2	1.3
1080	1859	7582	5723	2,921.3	2.2	1.3
1100	2005	8072	6067	3,092.1	2.3	1.3

Detector: 3

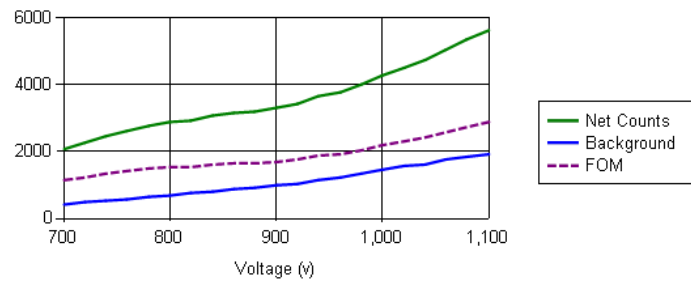

Voltage	Background Counts	Source Counts	Net Counts	Figure Of Merit	T1/T2	T2/T4
700	401	2471	2070	1,126.7	2,070.0	0.5
720	470	2748	2278	1,228.4	2,278.0	0.0
740	520	2974	2454	1,318.2	-1,227.0	2.0
760	567	3191	2624	1,405.6	2,624.0	0.0
780	637	3412	2775	1,474.0	2,775.0	0.0
800	688	3579	2891	1,528.2	206.5	7.0
820	771	3701	2930	1,529.3	112.7	26.0
840	807	3874	3067	1,600.8	35.7	86.0
860	858	3998	3140	1,631.6	10.5	24.8
880	905	4095	3190	1,650.6	4.9	64.7
900	970	4258	3288	1,694.2	3.2	46.5
920	1037	4467	3430	1,762.9	2.6	15.2
940	1132	4772	3640	1,865.6	2.3	5.9
960	1225	4990	3765	1,921.5	2.1	3.1
980	1341	5347	4006	2,039.5	2.1	2.1
1000	1440	5727	4287	2,181.9	2.0	1.6
1020	1552	6067	4515	2,293.6	2.0	1.5

1040	1615	6357	4742	2,410.7	2.0	1.4
1060	1761	6802	5041	2,557.5	2.0	1.3
1080	1830	7167	5337	2,711.7	2.1	1.3
1100	1912	7546	5634	2,865.0	2.1	1.3

Detector: 5

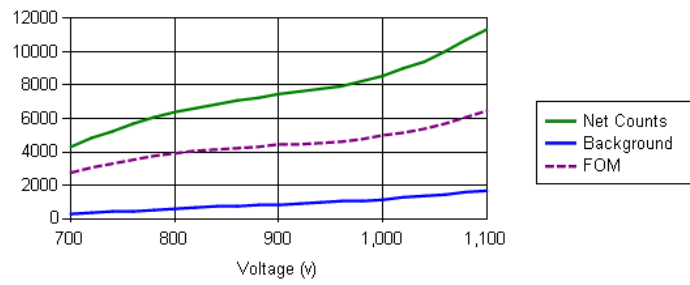

Voltage	Background Counts	Source Counts	Net Counts	Figure Of Merit	T1/T2	T2/T4
700	309	4577	4268	2,737.5	853.6	1.3
720	373	5213	4840	3,072.1	4,840.0	1.0
740	420	5671	5251	3,312.1	5,251.0	0.0
760	463	6120	5657	3,554.3	2,828.5	-1.0
780	525	6571	6046	3,760.7	2,015.3	1.0
800	586	6965	6379	3,929.9	2,126.3	-1.5

Page 1 Of 3

Measurement Results Report

This report lists the Activity Results between the selected Start and End dates. It is possible to limit the report by Start and End Dates, by the last n results (note enter 0 for unlimited results), Alarms Only and Person ID:

Activity Results Summary

Result ID	Step	Person ID	Result Date		Gross Activity (nCi)	Gross MDA (nCi)	Cobalt Activity (nCi)	Alarm Type	Gross Zone	Co60 Zone
68	Centre facing Rear		20/08/2008 09:25	Q	48.7	11.8	0	Normal	5	
67	Centre facing Rear		20/08/2008 09:24	Q	113	40	0	Normal	centroid	
66	Centre facing Rear		20/08/2008 09:24	Q	45.5	11.9	0	Normal	5	
65	Centre facing Rear		20/08/2008 09:23	Q	116	39.2	0	Normal	centroid	
64	Centre facing Rear		20/08/2008 09:23	Q	<MDA	10.3	0	None	7	
63	Centre facing Rear		20/08/2008 09:21	Q	23.5	11.7	0	None	3	
62	Centre facing Rear		20/08/2008 09:21	Q	<MDA	11.5	0	None	5	
61	Centre facing Rear		20/08/2008 09:18	Q	<MDA	11.5	0	None	5	
60	Centre facing Rear		20/08/2008 09:17	Q	<MDA	39	0	None	centroid	
59	Centre facing Rear		18/08/2008 15:25	Q	<MDA	11.2	0	None	4	

Page 1 Of 1

Press on one of the ID records to display the Activity Results Detail for the selected Results ID:

Activity Results Detail

Result ID 68
 Step Centre facing Rear
 Date 20/08/2008 09:25:41
 Person ID
 Monitor Time (s) 12
 Quickscan Time (s) 4
 Result Type Quickscan Contaminated
 Measurement Confidence 2



Alarms:

Detector / Zone	Alarm Type	Activity (nCi)	Background Rate (cps)	Net Count Rate (cps)	Effective Alarm Level (cps)	Efficiency (%)	Alarm Multiple	T1 / T2
5	Normal	48.7	862.7	195	132	10.81	1.5	3.11
7	Normal	42.6	791.2	186	148	11.78	1.3	3.05

Raw Counts:

Detector	Threshold	Gross Count Rate (cps)	Background Count Rate (cps)	Net Count Rate (cps)
1	1	732.8	723.9	8.8
1	2	168.5	167.7	0.8
1	3	161.3	159.9	1.4
1	4	73.3	71.2	2.1
1	5	36.3	34.9	1.3
2	1	775	803.2	-28.2
2	2	140	147.9	-7.9
2	3	132	140.5	-8.5
2	4	57	55.7	1.3
2	5	21.3	23.2	-2
3	1	920	878.6	41.4
3	2	175.8	161.5	14.2
3	3	172.8	156.5	16.3
3	4	66	64.8	1.2
3	5	25.3	23.4	1.9
4	1	738.3	745.1	-6.9
4	2	127.8	136.9	-9.2
4	3	121.8	129	-7.3
4	4	48.5	48.6	-0.1
4	5	22.3	20.2	2.1
5	1	1079	887.5	191.5
5	2	220.8	159.2	61.6
5	3	205.3	146.6	58.6
5	4	71.5	62.6	8.9
5	5	21.5	24.7	-3.2
6	1	708	677.9	30.1
6	2	110.5	115.1	-4.6
6	3	102.3	108.8	-6.6
6	4	31.8	42.6	-10.9
6	5	12.5	20.6	-8.1
7	1	998.8	813.3	185.4
7	2	201	140.1	60.9
7	3	190.5	131.1	59.4
7	4	61.3	52.2	9
7	5	21.8	22.1	-0.3
8	1	886.8	918.2	-31.5
8	2	172.8	171.7	1
8	3	161.8	159.8	2
8	4	68.5	71	-2.5
8	5	34.3	37	-2.8

Variance Report This report lists the Background Variance Test Summary Results between the selected Start and End dates. It is possible to limit the report by Start and End Dates:

Background Variance Test Summary

Test ID	Test Date	Pass / Fail	Lower Limit	Upper Limit	Cycles	Cycle Duration (s)	Description
4	04/10/2007 13:57:17	Fail	0.67	1.5	10	100	
3	04/10/2007 11:28:53	Fail	0.67	1.5	3	100	
2	04/10/2007 11:23:47	Fail	0.67	1.5	10	100	
1	04/10/2007 11:15:05	Fail	0.67	1.5	10	100	

Page 1 Of 1

Press on one of the ID records to display the Background Variance Test Results Detail for the selected Test ID:

Background Variance Test Results Detail

Results ID: 3		Test Date: 04/10/2007 11:28:53		
Detector	Pass / Fail	VT	Variance	Mean (cps)
1	Fail	0.2675	7351	275
2	Fail	0.5373	13970	260
3	Fail	2.666	68990	259
4	Pass	0.7173	18310	255
5	Fail	0.6552	14530	222
6	Fail	0.3495	8599	246
7	Fail	0.2675	7351	275
8	Fail	0.2675	7351	275
centroid	Fail	2.12	438000	2070
double1	Pass	1.485	79240	534
double2	Fail	2.89	138900	481
double3	Fail	0.6659	33070	497
double4	Fail	0.535	29400	550
double5	Fail	0.4472	23290	521
double6	Fail	0.4539	22750	501
double7	Fail	0.3215	16560	515
double8	Pass	0.6777	36240	535
triple1	Fail	2.122	160300	755
triple2	Fail	2.122	160300	755
triple3	Pass	0.8595	66310	771
triple4	Fail	0.6622	52690	796
triple5	Fail	0.1981	15380	776
triple6	Fail	0.5467	41620	761
triple7	Fail	0.2122	16760	790
triple8	Fail	1.928	153000	794

Archives Select Data|Archives to select an Archive to be saved:

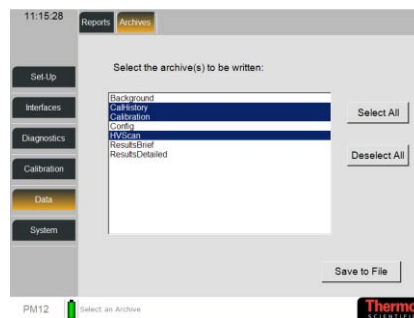

To select archives to be saved, highlight the archive on the screen by pressing individual names or press the Select All button. Press the Save to File button to display the edit options window:

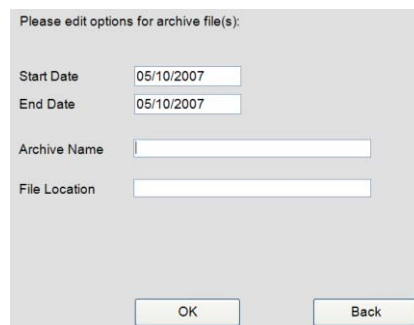

Select a Start / End Date and enter an Archive Name and File Location. Select the OK button to write the archives. A confirmation will be displayed.

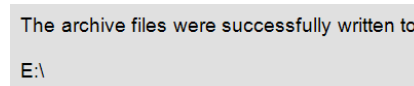

System Menu

Actions Select System|Actions to take PM12 out of Contamination Mode, quit the application or shutdown the system



To clear a contamination, press the Contamination Cleared button.

To backup a Calibration, press the Backup Calibration button. A confirmation message will be displayed. Select OK to close the application.

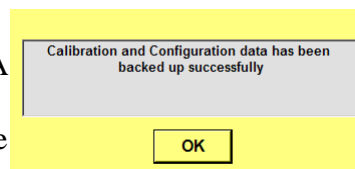

To exit the PM12 application, press the Exit to Application Login button. A confirmation message will be displayed. Select OK to close the application.

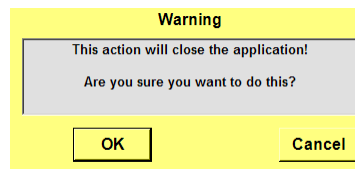

To shutdown the entire system, press the System Shutdown button. A confirmation message will be displayed. Select OK to shut the entire system down.

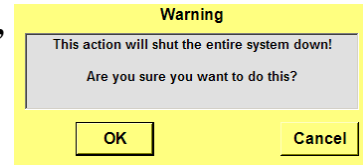

Setup Select System|Setup to set the location, volume, date / time and time zone

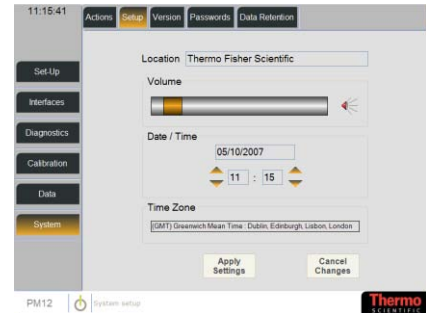

To change the Location, enter the location using the alpha-numerical field.

To adjust the volume, move the orange bar to the left to decrease the volume and to the right to increase the volume. To test the volume, press on the loudspeaker icon. See Notes regarding Volume Levels (page 5-66).

To change the Date, press on the date field and select a date. Note that the format of the date depends on the Language type selected in Options screen - see Options (page 5-8). Select the Apply Settings button to save.

To change the Time, use the Up/Down buttons to change the hours and minutes. Select the Apply Settings button to save.

To change the Time Zone, press on the TimeZone field and select a time zone from the pre-defined list. Select the Apply Settings button to save.

Notes regarding Volume Levels For guidance, 85dBA is obtained at about 35% volume control level and 100dBA at 100% volume control level.

Version Select System|Version to view the File version information, including the PM12 Issue and Version numbers

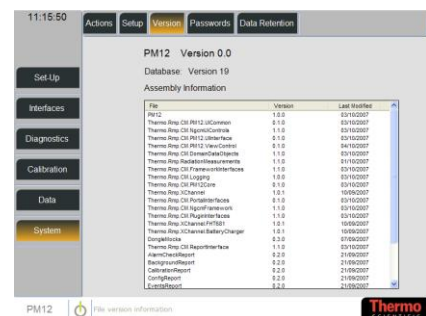

Passwords Select System|Passwords to change the passwords for the current User Level and levels below



There are three levels of user – Health Physicist, Technician and ThermoFisher. The PM12 is supplied with unique default passwords for each level as follows:

User	Password
Health Physicist	"hp"
Technician	"tech"
ThermoFisher	Contact Thermo Fisher Scientific

To change the Password for a select User, press in the Select User field to display the user roles. Select a User and select OK. Enter a Password and confirm the Password.

Ensure each password level has a unique Password – under no circumstances should all three roles be assigned the same password.

Data Retention Select System|Data Retention to save the specified data for a set number of months

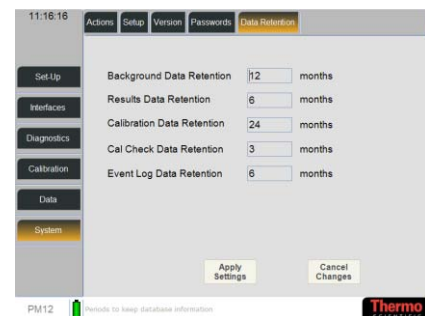

Enter the length in time (months) for how long each type of data is to be retained. Data is automatically deleted that is older than the specified time. The following data types are displayed:

- Background Data Retention (months)
- Results Data Retention (months)
- Calibration Data Retention (months)
- Cal Check Data Retention (months)
- Event Log Data Retention (months)

User Mode

The basic operation of the PM12 is as follows:

- Upon power up, system diagnostics are run – see [Start Up Checks \(page 5-72\)](#).
- Upon successful system diagnostics, the PM12 establishes a new Background – see [Establishing a new Background \(page 5-73\)](#).
- The system enters the Background Monitoring Mode – see [Normal Background Monitoring \(page 5-74\)](#).
- To commence monitoring, the user enters the portal – see [Entering the Portal \(page 5-77\)](#).
- Monitoring starts when the user is correctly positioned in the portal – see [Commence Monitoring \(page 5-80\)](#).
- Monitoring continues for a period determined by the mode of use:

The measurement time is preset for Walk Through mode.

In Single Step mode, monitoring continues for a period determined by the required confidence levels and the current background

In Two Step, Three Step and Stand and Turn modes, the user is required to undertake two count in different positions, where the counting times are dependent on the confidence levels and the background count rate.

- Monitoring may be interrupted due to the result of a Quick Scan assessment (see [Options \(page 5-8\)](#)), or if a significant change in background conditions is detected during the measurement – see [Background Change during Measurement \(page 5-86\)](#). *Note that this interruption does not apply to Walk Through mode.*
- At the end of the Monitoring period, activity is calculated and compared against a set of alarm thresholds. A simple CLEAR/ALARM indication is given along with details of the measured activity. If the activity is above the alarm threshold, NBR algorithms are used to attempt to determine the proportion of activity that is due to NORM – see [Monitoring Result \(page 5-87\)](#).
- Upon completion of monitoring, the user exits the portal - see [Exiting the Portal \(page 5-93\)](#).

User Screen An example of the PM12 screen is displayed below:

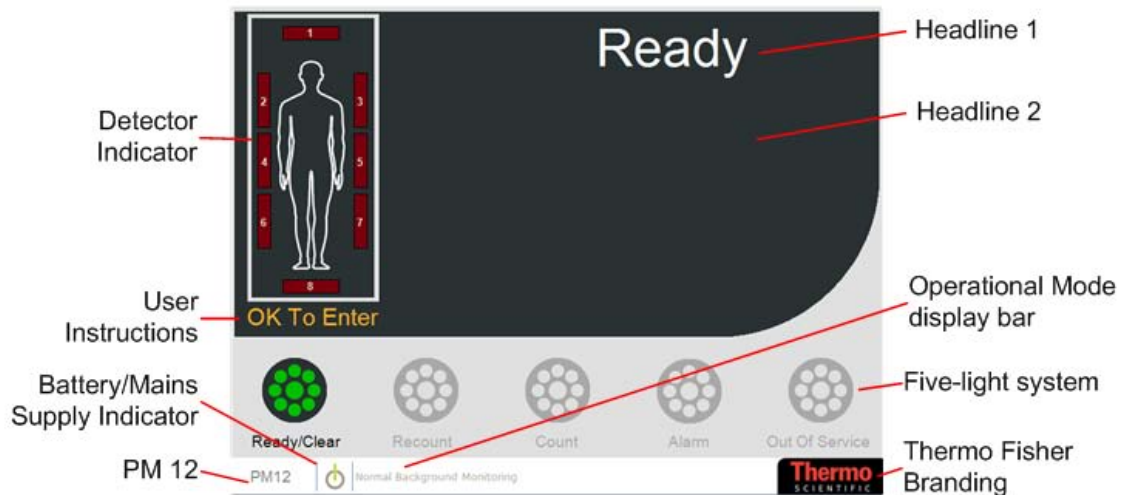

Figure 1 Example of PM12 User Screen

The PM12 User Screen displays the following:

- Detector Indicator which mimics the Annunciator Overlay display (see [Detector Indicator \(page 5-71\)](#))
- User Instructions - *note that some of these messages are user-definable (see [Messages \(page 5-21\)](#)).*
- [Battery/Mains Supply Indicator \(page 5-97\)](#)
- PM12 – press here to enter [Administrator Mode \(page 5-1\)](#).
- Headline 1 and 2 - *note that some of these messages are user-definable - see [Messages \(page 5-21\)](#)*
- Operational Mode display bar – this also gives a description of the selected menu in Administration Mode
- Five-light system which mimics the Annunciator Overlay display (see [Five Light System \(page 5-71\)](#))
- Thermo Fisher Scientific branding

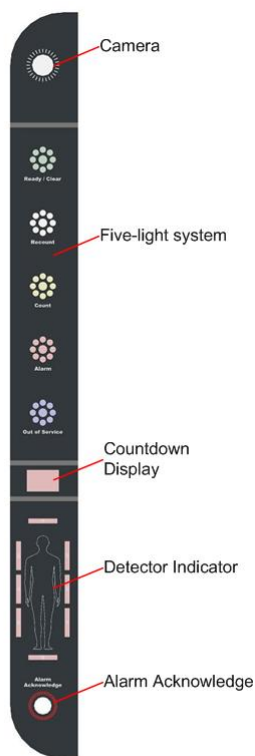
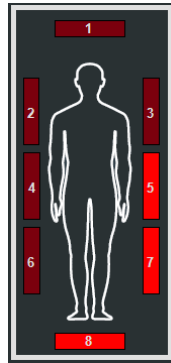

Figure 2 Example of PM12 Annunciator Overlay

The PM12 Annunciator Overlay displays the following:

- Camera (see [Camera \(page 5-80\)](#))
- Countdown Display which mimics the User Screen
- Five-light system which mimics the User Screen (see [Five Light System \(page 5-71\)](#))
- Detector Indicator which mimics the User Screen (see [Figure 1 Example of PM12 User Screen \(page 5-69\)](#) and see [Detector Indicator \(page 5-71\)](#))
- Alarm Acknowledge, which mimics the Results User Screen (see [Figure 3 Example of Result display on the PM12 User Screen \(page 5-87\)](#)). For more information regarding user acknowledgement of alarm, see [ALARM Acknowledge \(page 5-91\)](#).

Detector Indicator



Following a measurement, if a contamination is present, the lit detectors will identify where the contamination has occurred as follows:

Individual Detector	Bar is solid
2 Detector Sum Zone	All bars in triggered sum zone, every 3 rd flash suppressed (i.e. flash-flash-blank-flash-flash-blank)
3 Detector Sum Zone	All bars in triggered sum zone, every 4 th flash suppressed (i.e. flash-flash-flash-blank-flash-flash-flash-blank)
Centroid Sum Zone	All detector bars flash, every other flash suppressed (i.e. flash-blank-flash-blank)

Five Light System

The Five-Light system gives a visual indication of the current operation of the PM12.



The green LED indicates that the PM12 is READY for operation
OR
Indicates that the result of a measurement is CLEAR.

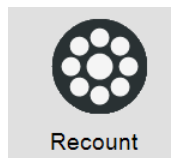

The white LED indicates that a recount is necessary.



The amber LED indicates that a measurement is in progress.

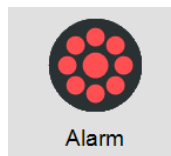

The red LED indicates that an alarm or violation has taken place during measurement.
OR
Indicates that the PM12 is contaminated.

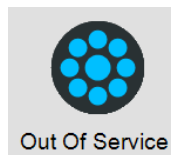

The blue LED indicates that the PM12 is not in use.

Voice Prompts Note that if Voice Prompts is enabled (see [Options 1 \(page 5-8\)](#)), instructions are given verbally. If Voice Prompts is not enabled, an Audible Indication is sounded. See [Audible Indications \(page 3-4\)](#) for further information.

Switch On

Start Up Checks When the PM12 unit is powered on, the "SYSTEM SELF TESTING" message is displayed. In this state, diagnostics are run to validate the state of the PM12 to include:

- Instrument Configuration File validation
- XChannel device communication test i.e. checks communication with each peripheral
- Select calibration validity checks, i.e. check efficiency factors are available for all detectors and that at least one valid alarm is set

If the System Self Testing passes, the "Self Checks pass" message is displayed for a few seconds.

Database connectivity check, i.e. check that the local database is available.

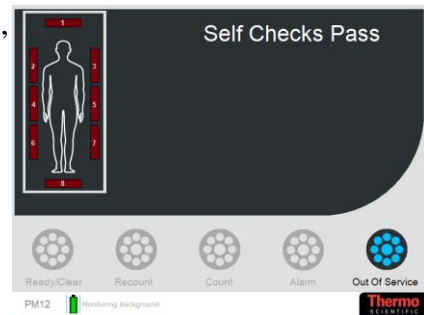
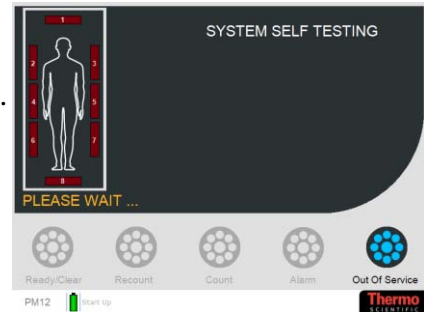

If the System Self Testing fails, the "Out of Service – Terminal Error" message is displayed (note that the reason for the error may be displayed in the message bar at the bottom of the screen).

See

[Out Of Service \(page 5-94\)](#).

See [Maintenance and Trouble Shooting \(page 11-1\)](#) for further information regarding the Self Test Failures messages.

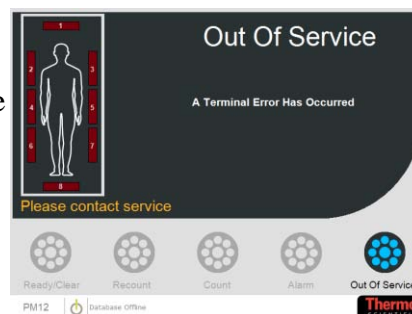

Out of Calibration

If the Calibration Required Interval option has been exceeded, then the "Out of Calibration" message is displayed – see [Params 1 \(page 5-13\)](#). To check the Calibration of the unit, see [Cal Check \(page 5-35\)](#).

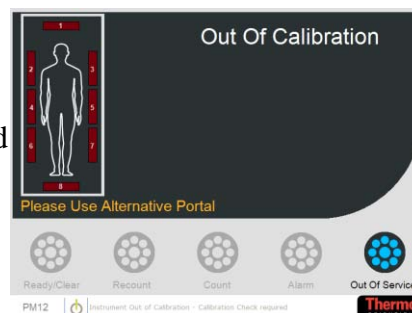

Establishing a new Background

Once the Self Checks have passed, PM12 will to acquire a new background and the "Updating Background" message is displayed.

See [Notes regarding Changing Background \(page 5-76\)](#) for more information regarding acquiring a background.

Note: If Quick Background is selected, the length of time taken to acquire a new background will be much shortened (see [Params 1 \(page 5-13\)](#)).

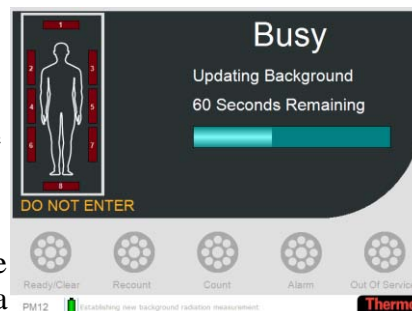

If the portal is entered when the PM12 is establishing a new background, background counting stops, the "Warning Portal is busy" message is displayed and an audible alarm will sound. To continue with the process, the portal must be vacated.

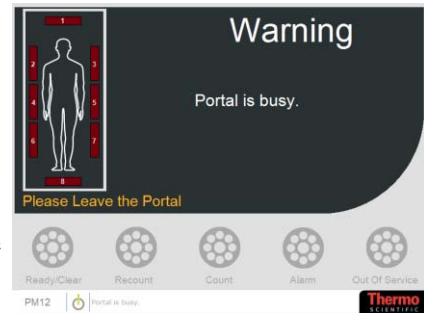

If the Barrier Enabled and the Ingress Closed During Background options are selected (see [Params 3 \(page 5-17\)](#)), the user is unable to pass through the barrier while a Background is being established.

When a new Background has been established, the "Ready – OK to Enter" message is displayed. The PM12 is now ready to start monitoring contamination.

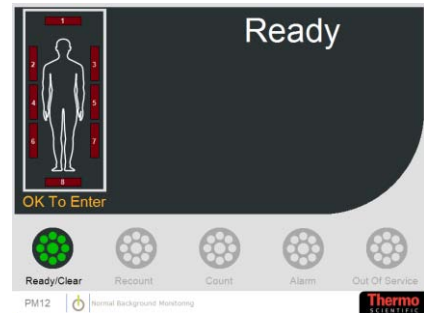

Normal Background Monitoring

This is the normal dormant state of the system. Normal Background Monitoring is continuous until:

1. The Portal is entered (probably as part of a measurement cycle) – see [Entering the Portal \(page 5-77\)](#) for more information.
2. A change in background is detected – see [Changes to the Normal Background Monitoring \(page 5-75\)](#) for more information.
3. A high or low background condition is detected - see [Notes regarding High Background \(page 5-96\)](#) for more information.

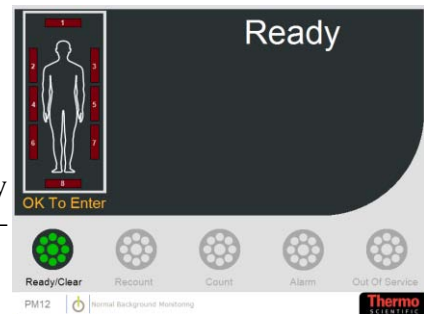

If the Barrier Enabled and the Ingress Closed When Ready options are selected (see [Params 3 \(page 5-17\)](#)), the user is unable to pass through the barrier while the Ready message is displayed.

Notes regarding Normal Background Monitoring

When the PM12 is not measuring, background is monitored in 1 second periods, each measurement contributing to a "rolling average", produced over a fixed 100 second period, i.e. 100 measurements. See [Background Update \(page 6-5\)](#) for more information.

These values are summed to give an overall mean Background value for the whole system. Changing or High background conditions can arise from these checks - see [Notes regarding Changing Background \(page 5-76\)](#) and [Notes regarding High Background \(page 5-96\)](#) for more information.

Changes to the Normal Background Monitoring

If a change in the Normal Background Monitoring is detected, PM12 will acquire a new background and the "Updating Background" message is displayed.

See [Notes regarding Changing Background \(page 5-76\)](#) for more information regarding acquiring a background.

If the portal is entered when the PM12 is updating the background, background counting stops, the "Warning Portal is busy" message is displayed and an audible alarm will sound. To continue with the process, the portal must be vacated.

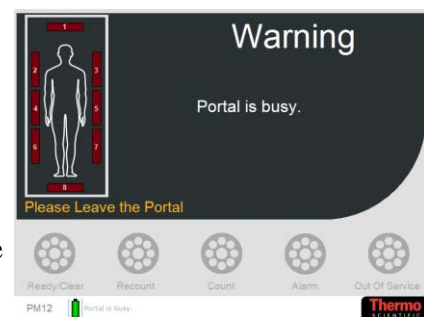
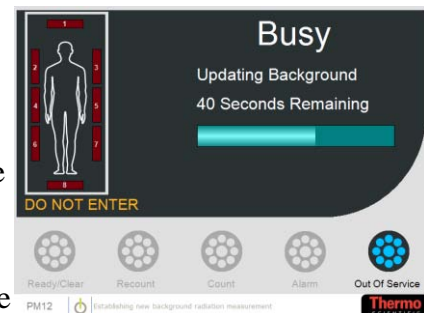

When a new Background has been established, the "Ready – OK to Enter" message is displayed. The PM12 is now ready to start monitoring.

See [Entering the Portal \(page 5-77\)](#) for more information.

If more than 15 minutes of continuous operation have elapsed since Normal Background Monitoring has commenced, PM12 will acquire a new background and the "Updating Background" message is displayed.

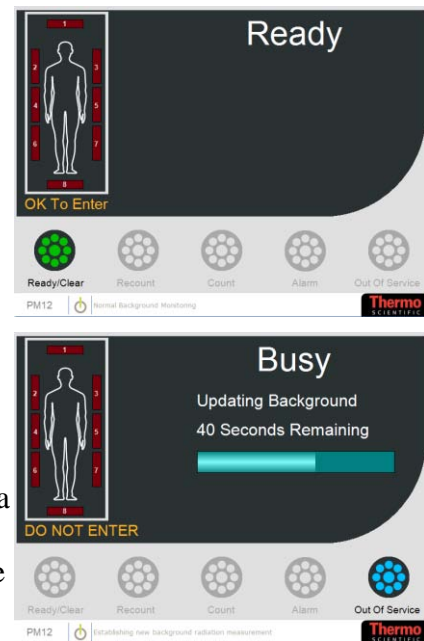

Notes regarding Changing Background

When a changing background has been detected or the instrument does not have a valid background (e.g. at System Startup), the system establishes a new background radiation measurement.

Each 1 second Background count for each detector, is checked against user defined statistical limits for variance from the stored average for that channel. If the count is acceptable it is incorporated into the stored average, otherwise the stored average for all channels is discarded, the blue Alarm lamp will light and "Updating Background - Please Wait" message is displayed while a fresh 100 second Background is accumulated - see [Background Update \(page 6-5\)](#) for more information.

Note: If Quick Background is selected, the length of time taken to acquire a new background will be much shortened (see [Params 1 \(page 5-13\)](#)).

Monitoring

Entering the Portal

The PM12 can be configured with the following options to control how personnel use the portal (see [Options 2 \(page 5-10\)](#) for further information):

- Is a Front Barrier enabled? (see [Params 3 \(page 5-17\)](#))
- Is a User ID required?
- Can the portal be entered from one direction only or from both
- Is a camera installed to take a picture of the user?
- Which Step Mode required?

Entering through the Front Barrier

The PM12 can be configured to use a Barrier through which the user must pass before entering and/or exiting the portal (see [Params 3 \(page 5-17\)](#) for further information). The following types of Barriers are available:

- Doors (in PM12C, doors may be selected as the Exit Barrier)
- Barrier (in PM12C, Barrier may be selected as the Entry Barrier)
- Unpowered Doors
- Turnstile

If Enable Front Barrier is ticked (see [Params 3 \(page 5-17\)](#)), the front Barrier is opened.

See [Voice Prompts \(page 5-72\)](#) for information regarding verbal instructions.

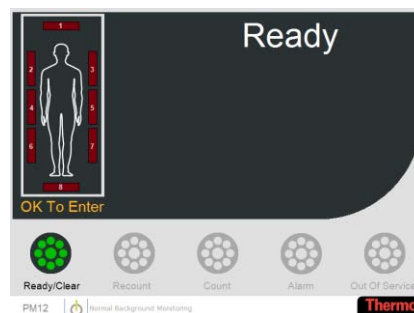

Violations during Entry

If during entering through the Barrier, there is a problem with the Barrier, the following error message is displayed:

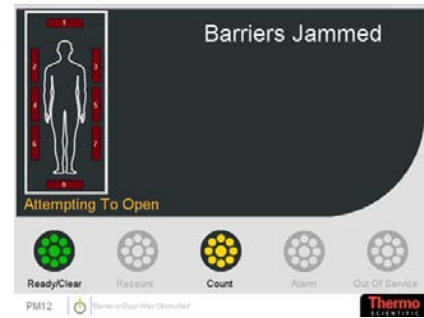

User ID

The PM12 may be fitted with an external device on either or both sides of the portal to provide identification of the user. This device may include, but not be limited to one of the following device types:

- Barcode scanner
- Magnetic swipe card reader
- RFID reader
- Electronic Dosimeter reader
- Keypad

Note that when a device is fitted, the user must enter the portal from the same side as the reader.

If User ID Required is ticked (see [Options 2 \(page 5-10\)](#)), the user is requested to enter their ID before entering the portal.

See [Voice Prompts \(page 5-72\)](#) for information regarding verbal instructions.

The user scans their identification at the barcode reader. The measurement process will not continue until this is successful.

Once the User ID has been successfully scanned and the user steps into the portal, the following "Welcome" message is displayed:

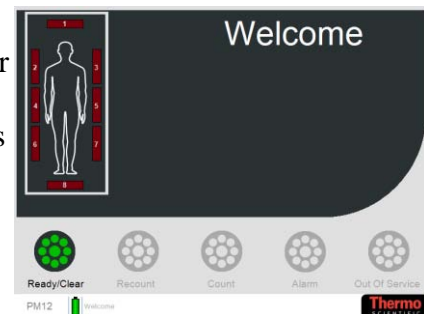
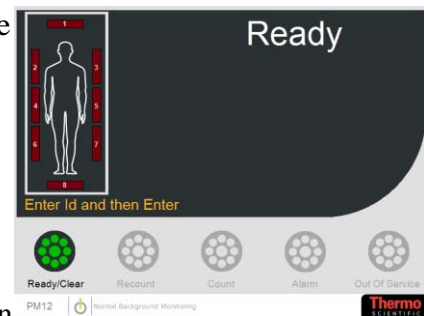

If the user enters the portal without entering their ID, the "No ID" error message is displayed:

See [Voice Prompts \(page 5-72\)](#) for information regarding verbal instructions.

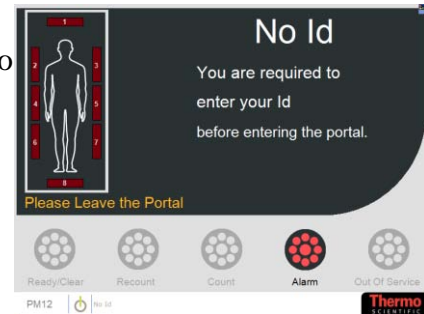

If the User does not enter the portal within the Id Timeout Period (see [Options 2 \(page 5-10\)](#)), the PM reverts back to the "Ready - OK to Enter" message as below:

If User ID Required is not ticked, the PM displays the "Ready - OK to Enter" message:

The user enters the portal to commence the measurement process.

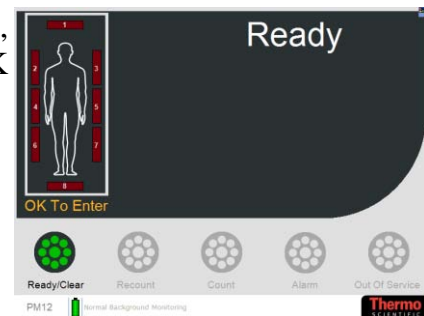

As the user steps into the portal, the following "Welcome" message is displayed:

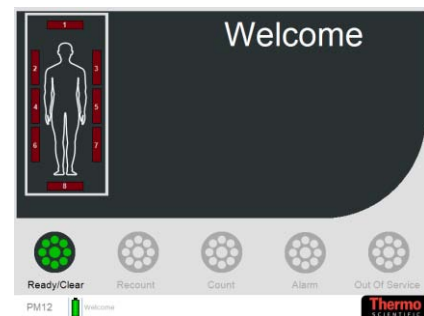

Direction of Entry

If Unidirectional Mode is ticked (see [Options 2 \(page 5-10\)](#)), the user must enter the portal from the correct direction, otherwise the following "Warning" message is displayed:

See [Voice Prompts \(page 5-72\)](#) for information regarding verbal instructions.

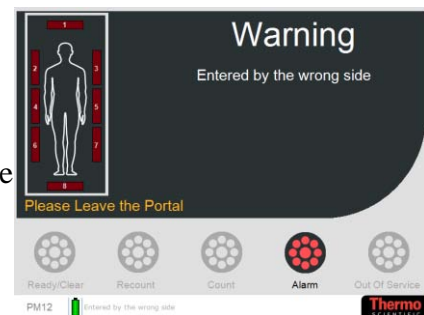

Camera If Camera(s) is/are installed (see [IDS Camera \(page 5-23\)](#)), a digital picture of the user is automatically taken as they enter the portal, depending on the Camera on Alarm option set in [Options 1 \(page 5-8\)](#).

If the PM12 is set for unidirectional mode (see [Options 2 \(page 5-10\)](#)), only one camera is needed on the ingress side.

If the user is able to enter the portal from both sides, two cameras are required so that their image can be captured from either side. The PM12 is able to recognise which camera to use by detecting which beam has been broken (see [Optical Sensors \(page 4-7\)](#)).

Commence Monitoring

The Portal Monitor can be used in one of five modes (see [Options 2 \(page 5-10\)](#) for settings). Depending on the type of mode selected, the PM will display instructions to the user asking them to stand in and/or move to specific areas of the portal. See [Voice Prompts \(page 5-72\)](#) for information regarding verbal instructions.

- Walk Through – in this mode, the user just walks through the portal. See [Walk Through Mode \(page 5-81\)](#).
- Stand and Count (or Single Step) - in this mode the user steps into the portal, waits while the measurement is taken and exits once the result is displayed. In this mode, only the user's Central measurement is taken. See [Stand and Count Mode \(page 5-81\)](#).
- Two Step – in this mode, the user steps into the portal and is instructed to stand with his back against one wall. A measurement is taken and then the user is instructed to stand with his front against the other wall. A measurement is taken and then the user can exit. In this mode, the user's Back and Front measurements are taken. See [Two Step Mode \(page 5-82\)](#).
- Three Step – this mode is a combination of Stand and Count and Two Step. In this mode, the user's Central, Back and Front measurements are taken. See [Three Step Mode \(page 5-83\)](#).
- Stand and Turn – in this mode, the user steps into the portal and a measurement is taken. Then the user is instructed to turn sideways and press the button in front before measurement is taken, exiting once the result is displayed. In this mode, the user's Central measurement is taken from both angles. See [Stand and Turn Mode \(page 5-84\)](#).

Note that if the Barrier is enabled and the Ingress Closed During Measurement option is selected (see Params 3 ([page 5-17](#))), the user is unable to pass through the barrier while measurement is taking place.

Walk Through Mode

If Walk Through Mode is enabled, the user walks through the portal.



If the user pauses in the portal, they are instructed to continue moving through the portal. See [Voice Prompts \(page 5-72\)](#) for information regarding verbal instructions.

Stand and Count Mode

If Stand and Count Mode is enabled, the user is instructed to move to stand centrally in the Portal.

See [Voice Prompts \(page 5-72\)](#) for information regarding verbal instructions.

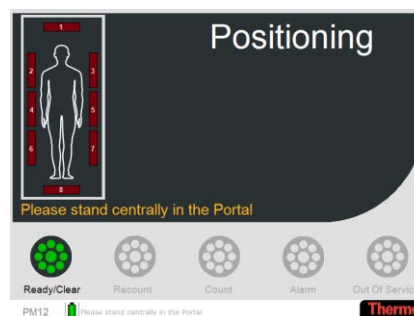

When the user is in the correct position, measurement starts:

Once monitoring commences, the PM12 displays the "Counting" message with an indication of the measurement time remaining.

On completion, the result is displayed. See [Monitoring Result \(page 5-87\)](#).

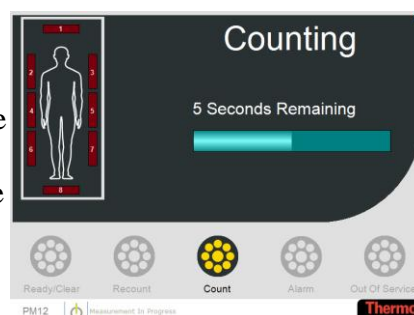

Two Step Mode

If Two Step Mode is enabled, the user is instructed to stand with their back against one wall of the Portal:

See [Voice Prompts \(page 5-72\)](#) for information regarding verbal instructions.



When the user is in the correct position, measurement starts:

Once monitoring commences, the PM12 displays the "Counting" message with an indication of the measurement time remaining.



If Complete all Steps (see [Options 2 \(page 5-10\)](#)) is not ticked and contamination is detected, the result is displayed at this stage and the measurement process is terminated.

Then the user is instructed to stand with their front touching the other wall of the Portal:

See [Voice Prompts \(page 5-72\)](#) for information regarding verbal instructions.

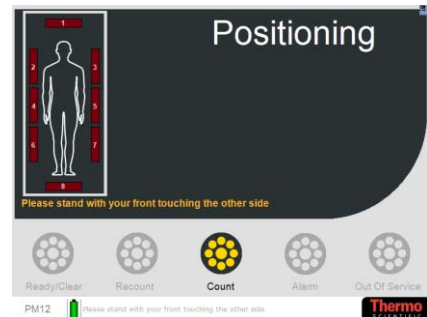

When the user is in the correct position, measurement starts:

Once monitoring commences, the PM12 displays the "Counting" message with an indication of the measurement time remaining.



On completion, the result is displayed. See [Monitoring Result \(page 5-87\)](#).

Three Step Mode

If Three Step is enabled, the user is instructed to move to stand centrally in the Portal.

See [Voice Prompts \(page 5-72\)](#) for information regarding verbal instructions.

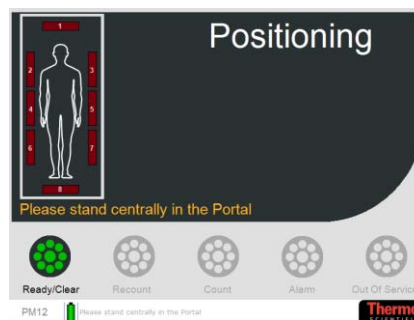

When the user is in the correct position, measurement starts:

Once monitoring commences, the PM12 displays the "Counting" message with an indication of the measurement time remaining.

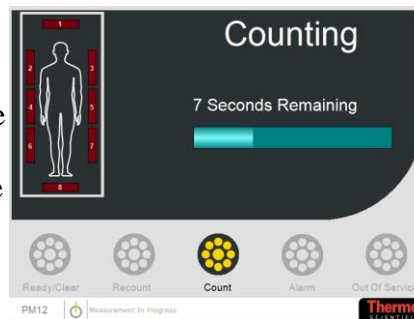

If Complete all Steps (see [Options 2 \(page 5-10\)](#)) is not ticked and contamination is detected, the result is displayed at this stage and the measurement process is terminated.

Then the user is instructed to stand with their back against one wall of the Portal:

See [Voice Prompts \(page 5-72\)](#) for information regarding verbal instructions.

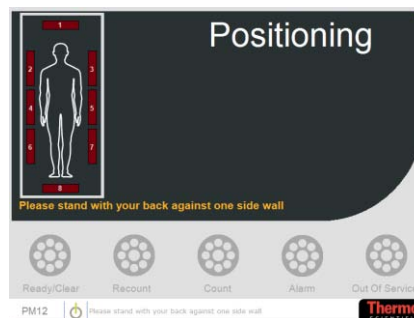

When the user is in the correct position, measurement starts:

Once monitoring commences, the PM12 displays the "Counting" message with an indication of the measurement time remaining.



If Complete all Steps (see [Options 2 \(page 5-10\)](#)) is not ticked and contamination is detected, the result is displayed at this stage and the measurement process is terminated.

Then the user is instructed to stand with their front touching the other wall of the Portal:

See [Voice Prompts \(page 5-72\)](#) for information regarding verbal instructions.

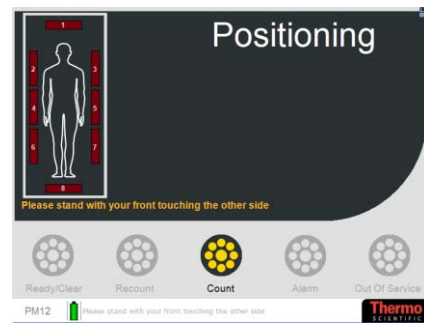

When the user is in the correct position, measurement starts:

Once monitoring commences, the PM12 displays the "Counting" message with an indication of the measurement time remaining.

On completion, the result is displayed. See [Monitoring Result \(page 5-87\)](#).



Stand and Turn Mode

If Stand and Turn Mode is enabled, the user is instructed to move to stand centrally in the Portal.

See [Voice Prompts \(page 5-72\)](#) for information regarding verbal instructions.

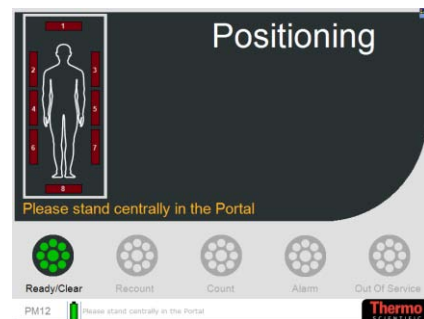

When the user is in the correct position, measurement starts:

Once monitoring commences, the PM12 displays the "Counting" message with an indication of the measurement time remaining.

If Complete all Steps (see [Options 2 \(page 5-10\)](#)) is not ticked and contamination is detected, the result is displayed at this stage and the measurement process is terminated.



Then the user is instructed to turn to face a wall and press the button in front:

See [Voice Prompts \(page 5-72\)](#) for information regarding verbal instructions.



When the user is positioned correctly in the portal, the PM commences monitoring:

Once monitoring commences, the PM12 displays the "Counting" message with an indication of the measurement time remaining.



On completion, the result is displayed. See [Monitoring Result \(page 5-87\)](#).

Violations during Monitoring

If during measurement, the user moves from the specified position, a "Warning" message is displayed asking them to return to position:

See [Voice Prompts \(page 5-72\)](#) for information regarding verbal instructions.

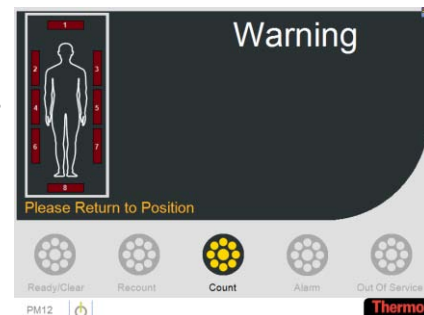

If during measurement, the user exits the portal on the ingress side before the measurement is complete, the "Measurement Abandoned" message is sounded.

See [Voice Prompts \(page 5-72\)](#) for information regarding verbal instructions.

If during measurement, the user exits the portal, the "Exit Violation" message is displayed requesting the user to re-enter the portal:

Note that the message is displayed for as long as set in the Exit Violation Duration option (see [Options 2 \(page 5-10\)](#)).

See [Voice Prompts \(page 5-72\)](#) for information regarding verbal instructions.

If the user does not return to the portal within the Exit Violation Duration, the portal reverts to the Ready screen (see [Entering the Portal \(page 5-77\)](#)).

If the user does not fully exit the portal on completion of measurement, the "Restart Required" message is displayed:

See [Voice Prompts \(page 5-72\)](#) for information regarding verbal instructions.

Background Change during Measurement

If a change in background is detected during a measurement, the user is instructed to exit the portal:

A new background check is required before monitoring can resume. See [Changes to the Normal Background Monitoring \(page 5-75\)](#).

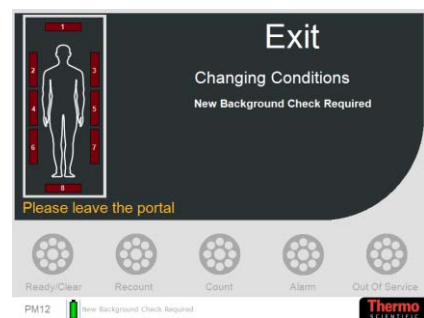
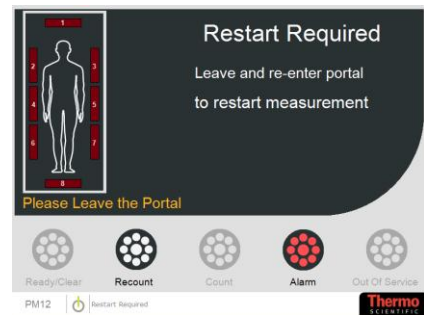
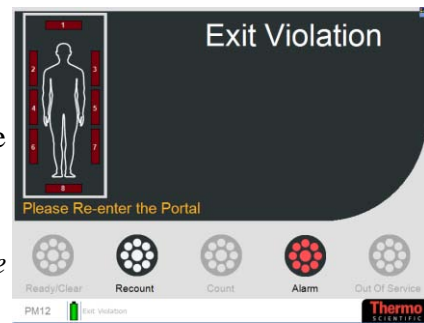

Monitoring Result

An example of the result screen is displayed below:

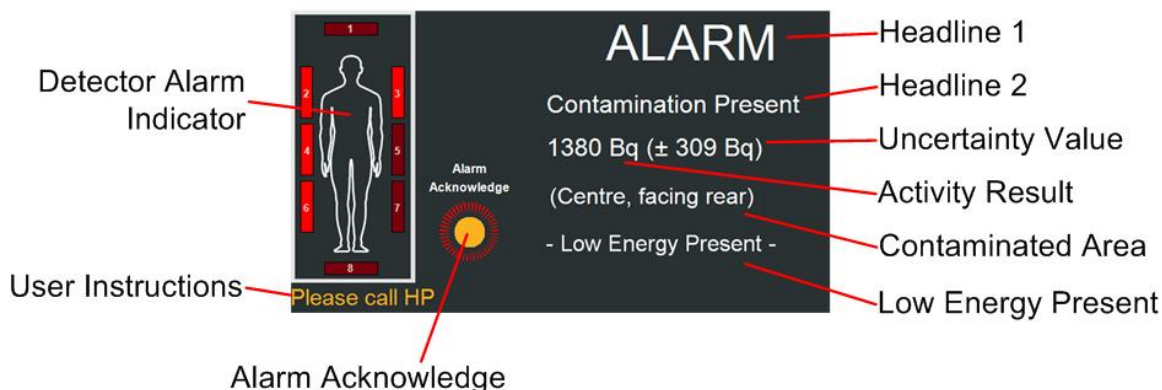

Figure 3 Example of Result display on the PM12 User Screen

The PM12 result screen displays the following:

- Detector Alarm Indicator, which mimics the Annunciator Overlay display (see [Figure 2 Example of PM12 Annunciator Overlay \(page 5-70\)](#) and see [Detector Indicator \(page 5-71\)](#))
- User Instructions
Note that some of these messages are user-definable (see [Messages \(page 5-21\)](#)).
- Alarm Acknowledge, which mimics the Annunciator Overlay display (see [Figure 2 Example of PM12 Annunciator Overlay \(page 5-70\)](#)). For more information regarding user acknowledgement of alarm, see [ALARM Acknowledge \(page 5-91\)](#).
- Headline 1 and 2 displaying the type of Alarm
Note that some of these messages are user-definable - see [Messages \(page 5-21\)](#)
- Uncertainty Value - see [Alarm Display \(page 5-90\)](#)
- Activity Result – see [Alarm Display \(page 5-90\)](#)
- Contaminated Area – see [Alarm Display \(page 5-90\)](#)
- Low Energy Present – see [Alarm Display \(page 5-90\)](#)

For more information regarding the options available to display results, see [Options 1 \(page 5-8\)](#) and [Options 3 \(page 5-12\)](#).

CLEAR Result If the measured contamination is below the alarm level or when Quick Scan indicates real-clean, the user is informed audibly and visually of the result, with instructions to exit the portal. The "Clear" message is displayed.

See [Voice Prompts \(page 5-72\)](#) for information regarding verbal instructions.

Note that this message is user-definable. See [Messages \(page 5-21\)](#) for more information.

At the end of the measurement sequence, the stored total background count is subtracted from the total measured count to give the net count which is compared with the effective alarm level.

Note that the Uncertainty Value and Activity results are displayed if enabled – see [Options 1 \(page 5-8\)](#) for more information.

Note that if Show Activity Value is set to On All (see [Options 1 \(page 5-8\)](#)), the Clear result will state that it is less than the MDA.

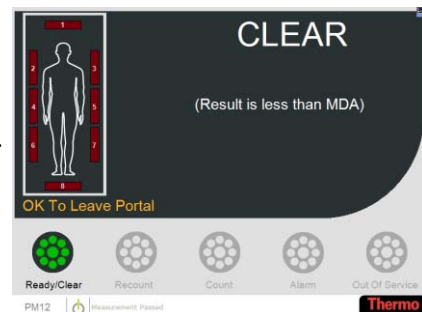
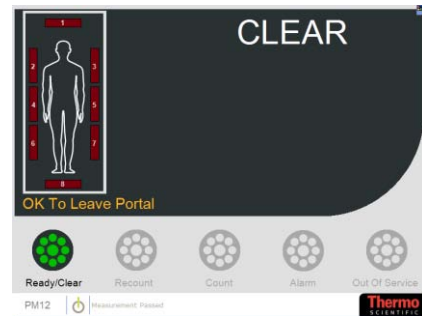

CAUTION: THE PM12 CANNOT DISTINGUISH BETWEEN A GRADUAL BUILD-UP OF CONTAMINATION AND SMALL BACKGROUND CHANGES. THEREFORE, IT IS STRONGLY RECOMMENDED THAT A REGULAR FRISKING PROCEDURE IS ADOPTED AND/OR AN INSPECTION OF THE BACKGROUND REPORT SHOULD INDICATE A BUILD-UP OF ACTIVITY – SEE [Reports \(PAGE 5-48\)](#).

Restart Required If the portal is not vacated within the Maximum Clear Display Time (see [Options 2 \(page 5-10\)](#)), the following Restart Required message is displayed:

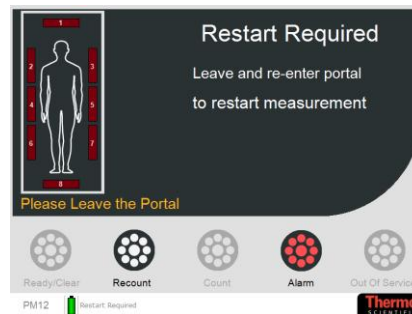

ALARM Result

Note that in the following section, the Activity Result or Uncertainty Value are not displayed. See [Alarms \(page 5-18\)](#) and [Alarm Display \(page 5-90\)](#) for further information regarding the Alarm displays.

If the measurement completes and the ordinary alarm level is exceeded or when Quick Scan indicates real-dirty, the Normal "ALARM" message display indicating that contamination is present.

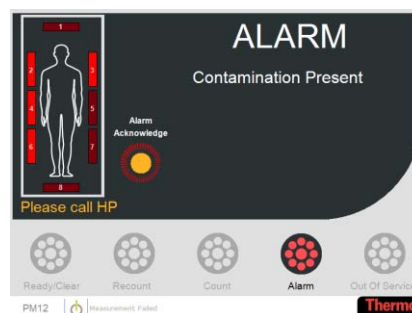

See [Voice Prompts \(page 5-72\)](#) for information regarding verbal instructions.

Note that this message is user-definable. See [Messages \(page 5-21\)](#) for more information.

See [ALARM Acknowledge \(page 5-91\)](#) for more information on clearing the alarms.

If the measurement completes and the high alarm level is exceeded, the "HIGH ALARM" message will display indicating that contamination is present.

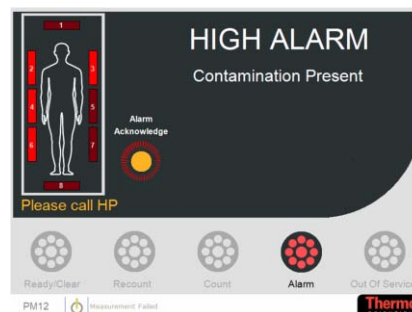

See [Voice Prompts \(page 5-72\)](#) for information regarding verbal instructions.

Note that this message is user-definable. See [Messages \(page 5-21\)](#) for more information.

See [ALARM Acknowledge \(page 5-91\)](#) for more information on clearing the alarms.

If the measurement completes and the Co60 alarm level is exceeded, the "Co60 ALARM" message will display indicating that contamination is present.

See [Voice Prompts \(page 5-72\)](#) for information regarding verbal instructions.

Note that this message is user-definable. See [Messages \(page 5-21\)](#) for more information.

See [ALARM Acknowledge \(page 5-91\)](#) for more information on clearing the alarms.

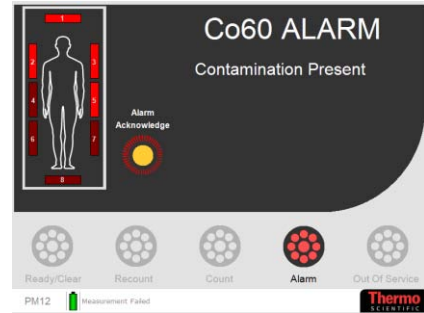

Alarm Display

The Alarm Display can be configured to show the Activity Result and /or Uncertainty Values. For further information on setting these values, see [Options 1 \(page 5-8\)](#).

If the Normal Alarm is triggered and the Uncertainty Value and Activity are enabled, the information is displayed as follows:



If the High Alarm is triggered and the Uncertainty Value and Activity are enabled, the information is displayed as follows:

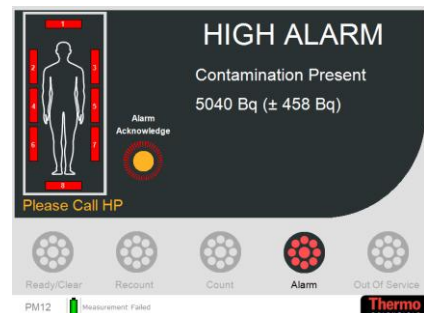

If the Co60 Alarm is triggered and the Uncertainty Value and Activity results are enabled, the information is displayed as follows:

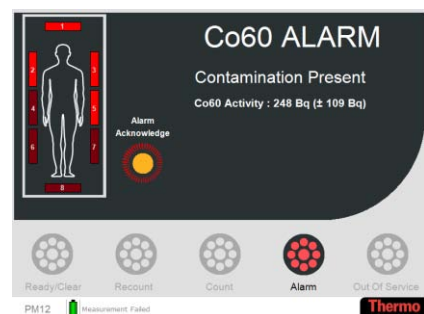

If Step Mode = Two Step, Three Step or Stand and Turn, the contaminated area is displayed.

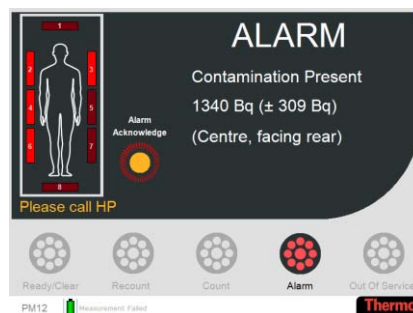

If Show Low Energy on Result is enabled, the information is displayed as follows:

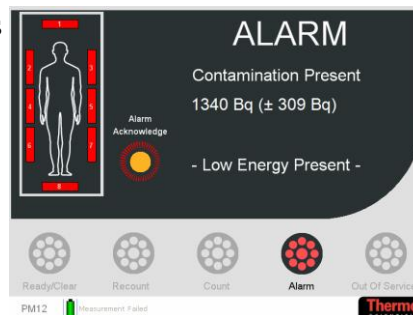

ALARM Acknowledge

For more information about setting of Alarm configurations, see [Options 2 \(page 5-10\)](#).

When an Alarm displays/sounds, it can be cleared in the following instances:

1. The alarm will automatically timeout after the Alarm Duration After Exit setting.
2. If User Can Cancel Alarm Sound is ticked, the User can acknowledge the alarm prior to the Alarm During After Exit timeout.
3. If Failure Display requires Supervisor Acknowledge is ticked, the alarm will display/sound until the Supervisor acknowledges the alarm (note that the Alarm Duration After Exit timeout is ignored in this case).

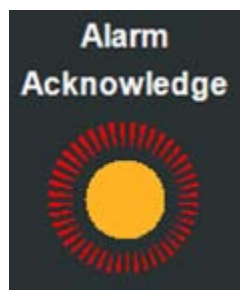

Residual Contamination Check

Following an alarm, if the Residual Contamination Check after Alarm option is ticked (see [Options \(page 5-8\)](#)), the Residual Contamination Count is performed.

See [Notes regarding Residual Contamination Check \(page 5-92\)](#) for more information.

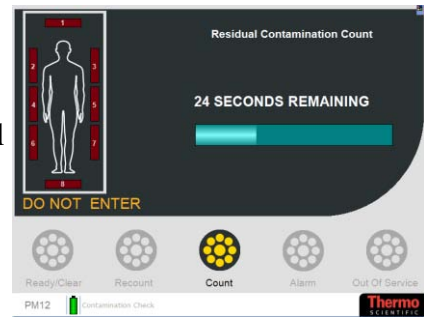

Notes regarding Residual Contamination Check

The Residual Contamination Check is run under the following circumstances:

- If the Residual Contamination Check before Background Check option is set - see [Options \(page 5-8\)](#).
- If Residual Contamination Check after Alarm option is set - see [Options \(page 5-8\)](#).

The Residual Contamination Check will verify that the current background count rate does not exceed the Background Count Rate before the alarm, by a statistically significant amount. If no contamination is found, the "Ready – OK to Enter" message is displayed and the PM12 reverts to Background mode.

However, if residual contamination is detected or the count rate from any detector exceeds 95% of the Amplifier "dead-time", then an Instrument Contaminated state exists. The "INSTRUMENT CONTAMINATED – DO NOT USE" message is displayed (see [Instrument Contaminated \(page 5-93\)](#) for more information).

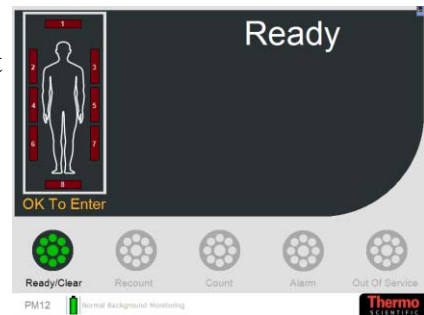
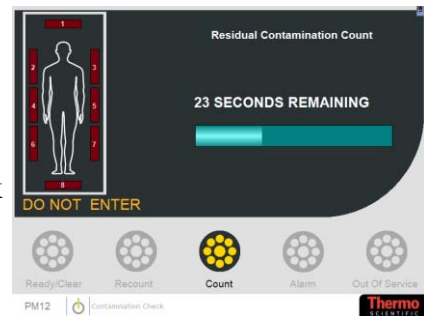

If the portal is entered during the Residual Contamination Check, the "WARNING – Preparing for Contamination Check" message is displayed.

See [Voice Prompts \(page 5-72\)](#) for information regarding verbal instructions.

Once the Portal is exited, the Residual Contamination Count recommences.

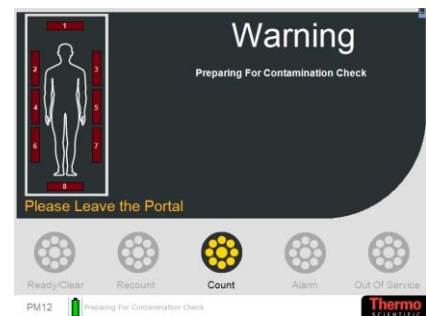

Instrument Contaminated

If the Instrument is contaminated, it is not possible to use the portal and background monitoring is suspended. Intervention by an Administrator is necessary to clear the contamination.

See [Actions \(page 5-65\)](#) for more information regarding clearing the Contamination



Once the contamination has been cleared, and User Mode is reinstated, the PM12 performs the System Self Testing – see [Start Up Checks \(page 5-72\)](#).

Exiting the Portal

The PM12 is available with the following options to control how personnel exit the portal:

- Exit Direction Restricted to Ingress Side on Fail (see [Options 2 \(page 5-10\)](#))
- Enable Rear Barrier (see [Params 3 \(page 5-17\)](#))

After a CLEAR result, the user must exit the portal.

If Enable Rear Barrier is ticked (see [Params 3 \(page 5-17\)](#)), the rear Barrier is released to allow the user out of the Portal.

After an ALARM result and Exit Direction Restricted to Ingress Side on Fail is ticked (see [Options 2 \(page 5-10\)](#)), the user must exit the portal to the entry side – otherwise the "Exit Violation" message is displayed:

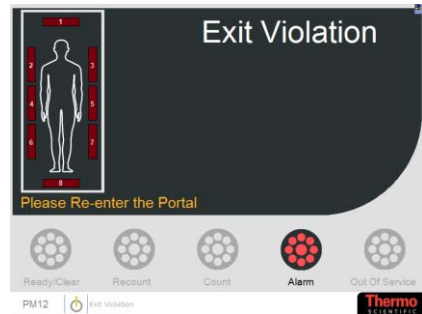

If Enable Front Barrier is ticked (see [Params 3 \(page 5-17\)](#)), the front Barrier is released to allow the user back into the "dirty" room. The rear Barrier does not open.

Once the user has successfully vacated the portal, the "Ready" message is displayed:

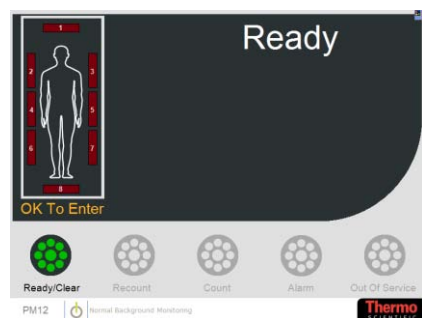

Out Of Service

If the portal is entered when the unit is Out of Service, the "EXIT Please Leave the Portal" message is displayed. The alarm will clear once the portal is empty.

See [Voice Prompts \(page 5-72\)](#) for information regarding verbal instructions.

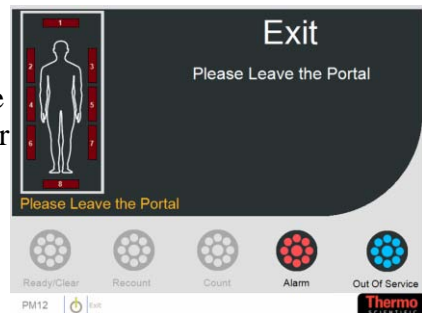

Critical Error If an error occurs during the establishment of a new background, the "Out of Service – Critical Error" message is displayed (note that the reason for the error may be displayed in the message bar at the bottom of the screen).

See [Voice Prompts \(page 5-72\)](#) for information regarding verbal instructions.

To clear this error, the state must be cleared in the Administration Mode (or will clear automatically when the Out of Service Recovery Interval is passed, see [Params 1 \(page 5-13\)](#) for more information).

See [Actions \(page 5-65\)](#) for more information regarding clearing the Critical Error.

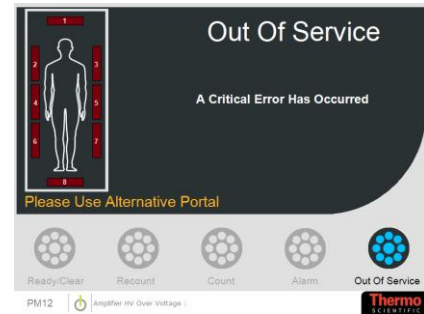

Terminal Error If an error occurs during the System Self Testing, the "Out of Service – Terminal Error" message is displayed (note that the reason for the error may be displayed in the message bar at the bottom of the screen).

See [Voice Prompts \(page 5-72\)](#) for information regarding verbal instructions.

To clear this problem, it is necessary to contact service or alternatively, Thermo Fisher Scientific.

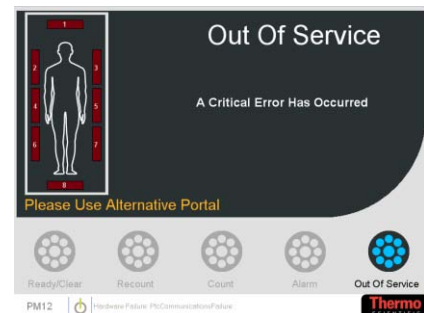

Temporary Error If High or Low Background occurs, the "Out of Service" message is displayed.

Note that this Temporary Error message is recoverable.

Notes regarding High Background

The "Out Of Service – Temporary Error has Occurred" message is displayed if High Background conditions exist.

See [Voice Prompts \(page 5-72\)](#) for information regarding verbal instructions.

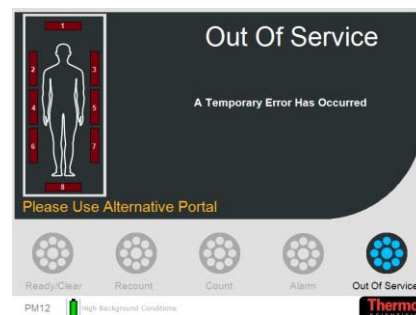

"Out of Service – High Background Conditions" message is displayed when the background activity prevents discrimination of the alarm level with the required confidence, in the Maximum Monitoring Time allowed (see [Params 2 \(page 5-14\)](#)) or the fixed monitor time in Walk Through mode. If the count rate from any detector exceeds 95% of the Amplifier "dead-time", a High Background fault condition will also be enforced. Contamination monitoring cannot be performed unless one or more of the following occurs:

1. The background activity drops sufficiently for the current alarm level to be detected, or,
2. The Health Physicist modifies one or more of the following parameters:
 - Increases the maximum monitoring time - see [Params 2 \(page 5-14\)](#).
 - Relaxes the Probability of Detection - see [Params 2 \(page 5-14\)](#).
 - Relaxes the Probability of False Alarm - see [Params 2 \(page 5-14\)](#).
 - Raises the Normal Alarm level - see [Alarms \(page 5-18\)](#).

[Minimum Detectable Activity \(MDA\) and High Background Criterion \(page 6-8\)](#) describes how the PM12 decides if a high background condition exists.

Notes regarding Low Background

The "Out Of Service – Temporary Error has Occurred" is displayed if Low Background conditions exist.

See [Voice Prompts \(page 5-72\)](#) for information regarding verbal instructions.

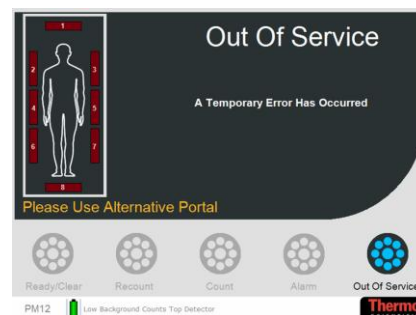

"Out of Service – Low Background Counts Top Detector" message is displayed when the count rate in the gross counts window over the 1 second background check period on any single detector falls below the threshold. It will remain in this state until the background count rate once again exceeds the threshold on all detectors.

Battery/Mains Supply Indicator

On the main screen, an icon is displayed on the bottom edge of the screen which indicates whether the PM12 is running on battery or mains supply as follows:



Indicates that the PM12 is running on battery.

See [Battery \(page 5-34\)](#) for more information regarding Battery Status including remaining battery life.



This icon indicates that the PM12 is running on mains supply.

Switch Off

Only an Administrator is able to exit the PM12 application – see [Actions \(page 5-65\)](#).

Chapter 6 Technical Description - Physics

Performance Characteristics

Introduction

The PM12 utilises eight identical large gamma-sensitive plastic scintillation detectors to monitor personnel passing through the portal. Three detector assemblies are located in each side of the portal, with additional detectors to monitor the head and feet.

The PM12 may operate in either minimum count time or maximum sensitivity mode (see [Options 3 \(page 5-12\)](#)). The user enters the desired alarm level in terms of activity located in the centre of the monitor, or activity located adjacent to a detector (or both) and the personnel monitor determines the appropriate alarm level and minimum necessary count time to achieve these levels.

The monitor may be used in five modes: walk-through, stand and count, stand and turn, two step and three step (see [Options 2 \(page 5-10\)](#)). Stand and Turn requires the user to stand centrally in the portal, but turn 90° when requested. The two step mode is the most sensitive for contamination on the body since the user stands against the detectors. The three step mode is a combination of stand and count and two step. Since the main requirement is to quickly prove the absence of contamination, rather than to identify which radio nuclides are present, large area Scintillation detectors, having high gamma sensitivity, are the most robust, low maintenance and cost effective solution.

The main problem with very large area gamma sensitive detectors is the high sensitivity to background radiation. This effect is minimised by shielding the detectors with 25 mm (0.5") or 50 mm (1") of lead.

The background is measured accurately, by monitoring over a long period. This is achieved by taking a series of 1 second background counts. Statistical checks on each background value guard against sudden changes. The average count is stored and used for background subtraction.

Software facilitates automatic calculation of monitoring time and programmable probabilities of False Alarm and Detection, Alarm levels and Efficiency Correction factors. A facility known as Quickscan (see [Options 1 \(page 5-8\)](#)), when enabled, will identify whether the article is either clearly clean or contaminated within a time period very much shorter than the

evaluated "worst case" monitoring time. Thus any user can be monitored accurately with known statistical certainty often in a few seconds. Five user definable discriminator thresholds are available which allow the rejection of interfering high energy photons from cosmic radiation and consequently improve MDA of selected radionuclide contaminants. In addition, these discriminators may be used to identify the presence of radionuclides emitting lower energy photons (such as medical); and radionuclides emitting high energy photons, typically ^{60}Co .

Spatial Response

Sensors in the portal detect the presence and position of the user. Depending on the mode selected, the user is prompted to stand in certain parts of the portal. The combination of the excellent coverage provided by the eight detectors, and the repositioning of the user, the instrument is able to obtain close to 4π coverage.

Figure 4 Variation in the Vertical Plane (page 6-14), Figure 5 Variation in response around the Body – horizontal plane (page 6-15) and Figure 6 Foot detector uniformity to ^{137}Cs (page 6-16) show the variation of response for activity distributed on various parts of a body.

A full type test report is available from Thermo Fisher Scientific on request.

Explanation of the Operational Calculations

Introduction

It is a requirement to measure personnel contamination as quickly and accurately as possible. Optimum detection efficiencies are required, with minimum statistical error in giving alarm indications. Measurement of contamination is dependent on ambient background level. Accuracy of measurement of both background and contamination is dependent on respective background and contamination monitoring times, self absorption and also on chosen probability of false alarm and probabilities of detection.

This section summarises the calculations employed by the CPU in determining whether the parameters selected by the user allow the monitor to operate correctly. The section then shows the criteria used to determine whether an alarm has occurred during a measuring sequence.

Description of Parameters Used in Calculations

The parameters used in the calculations are summarised and abbreviated as follows:

t_B	Background Update Time (seconds) is the time over which the average background counts have been accumulated. This time is usually fixed at 100s, but when Quick Background is enabled, this time is flexible and may be significantly lower than 100 s. Background measurements can only occur when the portal is not occupied.
B_{sum}	Total Average Background Count Rate (cps) is the sum of the mean background of all the detectors, measured over the background update time (t_B). This is a fixed 100 second rolling average in the PM12, unless Quick Background is enabled. See Notes regarding Normal Background Monitoring (page 5-75) .
B_{eff}	Effective Background while Monitoring (cps) is the sum of the mean background of all the detectors, B_{sum} , corrected for the effect of attenuation.
T_{cal}	Calculated Monitoring Time (seconds) is the minimum time required to perform a measurement according to the calculation in Calculation of the Monitoring Time (Tcal) (page 6-7) . The specified alarm level must be achieved with the required certainty in the Monitoring Time, which will depend upon a number of user programmable variables, as well as the Background.
T_{mon}	Actual Monitoring Time (seconds) is the actual time for which users are monitored. The calculated monitoring time (T_{cal}) is first rounded up to the nearest whole second. It is then compared with the user programmed Minimum Monitoring Time (T_{min}) and if $T_{cal} < T_{min}$ then T_{mon} is forced to be T_{min} , otherwise $T_{mon} = T_{cal}$. If $T_{mon} > T_{max}$ then a high background condition exists and normal monitoring is not possible (see Calculation of the Monitoring Time (Tcal) (page 6-7)).
T_{min}	Minimum Monitoring Time (seconds) is the Minimum Time for which users are monitored, regardless of the calculated Monitoring Time, see explanations of Tcal and Tmon above. The Minimum Monitoring Time is set from in Params 2 (page 5-14) .

- T_{\max} **Maximum Monitoring Time (seconds)** is the maximum time for which users are monitored, regardless of the calculated Monitoring Time, see explanations of T_{cal} and T_{mon} above. The Maximum Monitoring Time is set in [Params 2 \(page 5-14\)](#).
- C_{Act} **Contamination Alarm Level (variable unit)** is the activity level at which the user requires the alarm to be triggered. The alarm level is set in [Alarms \(page 5-18\)](#) and the units, e.g. dpm, Bq, nCi, may be selected in [Options 1 \(page 5-8\)](#).
- C_{cps} **Contamination Alarm Count-rate (cps)** is the count-rate at which the user requires the alarm to be triggered. It is equivalent to the Contamination Alarm Level set by the Administrator modified by the system Efficiency Correction Factor (E).
- C_{effect} **Effective Alarm Count rate (cps)** is the effective net count rate at which the PM12 normal alarm is triggered. The Contamination Alarm Count rate is modified to take account of the monitoring time, background statistical fluctuation and user programmed Probability of Detection. This ensures the Alarm set point reflects the measurement certainty required. The current Effective Alarm count rate may be viewed in [Information \(page 5-29\)](#). The C_{effect} calculation is detailed in [Contamination Alarm \(page 6-9\)](#).
- F **Probability of False Alarm (σ)** is the probability that a false alarm does not occur during a measuring sequence. The value of F in terms of sigma is set in [Params 2 \(page 5-14\)](#), where the associated probability is shown alongside in parenthesis. The value is usually set as high as possible, so that false alarms do not occur, e.g. one false alarm in a hundred measurements is a probability of 99% (2.4 σ), see [Table 6- Probability - Sigma and % \(page 6-12\)](#).
- P **Probability of Detection (σ)** is the probability that exactly one Alarm Level of contamination will cause an alarm. The value of P in terms of sigma is set in [Params 2 \(page 5-14\)](#), where the associated probability is shown alongside in parenthesis. The minimum allowable probability is 50% (zero sigma). Increasingly higher probabilities become increasingly subject to other parameters, particularly background level. The interrelationship will be discussed in the Calculation stages.

- E** **Efficiency Correction Factor** is the system efficiency (either centroid summed efficiency for all detectors, or individual detector contact efficiency) to the nuclide (E_{nuc}) or mixture of nuclides (E_{mix}) being monitored. E is given by the contamination count rate in a given time and divided by the activity. E is determined by calibrating with a known radionuclide source, as detailed in [Calibration for Other Nuclides \(page 10-3\)](#).
- A** **Attenuation Factor** is an allowance for attenuation of a background field by users being monitored. Values of A can be determined for each detector and body position by following the test procedure in [Attenuation \(page 5-46\)](#).
- DL** **Detection limit** or Minimum Detectable Count Rate (cps)
- M_{Act}** **Minimum Detectable Activity (variable unit)** is the minimum Activity the system can detect within the calculated monitoring time. It is very dependent on the programmed False Alarm rate and the prevailing background conditions and thus will continuously vary. The current Minimum Detectable Activity (MDA) may be viewed in [Information \(page 5-29\)](#) in the units specified in [Options 1 \(page 5-8\)](#). The MDA calculation is detailed in [Minimum Detectable Activity \(MDA\) and High Background Criterion \(page 6-8\)](#).
- R_{Act}** **Activity of Contamination (variable unit)**

Background Update

When the instrument is not monitoring a user, it will be monitoring background.

The background is monitored over 1 second check periods. Each 1 second period contributes to a rolling average of up to 100 periods.

As a contaminated user approaching the PM12 may affect the background of the instrument, background counts are pre-buffered for 2 seconds before being incorporated into the main background of the instrument. When a user is detected entering the instrument, these pre-buffered background counts are discarded.

To increase the availability of the PM12, the background update time (t_B) may be set to be dynamic, by utilizing the Quick Background option (see [Quick Background \(page 6-10\)](#)). When a new background count rate needs to be acquired, the instrument will only stay out of service for as long as it takes to acquire a background that results in a count time lower than the

maximum monitoring time (T_{max}) set for the instrument. At this point, the instrument is capable of making measurements that meet the Probability of False Alarm and Detection criteria, albeit with a longer Actual Monitoring Time (T_{mon}) than would be possible with a longer background counting time (t_B). This technique will allow monitoring to re-commence earlier and as more background counts are subsequently acquired, monitoring times will fall.

Because the FHT681 has an upper threshold that is typically configured as a "cosmic threshold", the gross counts are defined as counts in the energy band between the lower and upper thresholds. This is referred to as the gross counts window.

Changing Background

In relatively stable background conditions, 100 second "rolling average" accumulates an accurate background count. It is, however, slow to respond to sudden background disturbance and drift, making it is necessary to screen each count before incorporating it into the rolling average. Consequently to guard against inaccurate measurements and false alarms, the PM12 reads and checks the counts from each detector every second. A changing background conditions exists if either of the following conditions are true:-

Any one detector count shows a $M\sigma$ change from the stored average for that channel:

$$| [B_{av} - C_a] | \geq M \sqrt{B_{av}}$$

where B_{av} is the rolling average for any one detector.

C_a is the counts registered in the last one second background update.

M is the Detector Changing Background variable (see [Params 1 \(page 5-13\)](#)). The default value for M is 7. It is not recommended that M should be set below 4.0σ .

All eight detector counts show a $N\sigma$ change from their relevant stored averages in the same direction:

$$| [B_{av} - C_a] | \geq N \sqrt{B_{av}}$$

where B_{av} is the rolling average for any one detector.

C_a is the counts registered in the last one second background update.

N is the Gross Changing Background variable (see [Params 1 \(page 5-13\)](#)). It is not recommended that N should be set below 3.0σ .

The former expression detects gross changes in any single channel, while the latter guards against significant drift in all channels.

Calculation of the Monitoring Time (T_{cal})

After every successful background update, the average background for each channel is updated. The eight average backgrounds are then summed and a new monitoring time is re-calculated as follows:

$$C_{cps} = C_{Act} \cdot E \cdot Z_{Act}$$

where C_{Act} is one of the units below

Z_{Act} is the corresponding multiplier

Units	Unit Multiplier Z_{Act}
Bq	1
kBq	1000
Dpm	0.01666
pCi	0.037
nCi	37
μ Ci	3.7E4
mCi	3.7E7
Ci	3.7E10

T_{cal} found by solving:

$$C_{cps} = F \sqrt{\frac{B_{eff}}{t_B} + \frac{B_{eff}}{T_{cal}}} + P \sqrt{\frac{B_{eff}}{t_B} + \frac{B_{eff} + C_{cps}}{T_{cal}}} + \frac{1}{4} (F + P)^2 \left(\frac{1}{t_B} + \frac{1}{T_{cal}} \right)$$

In practice, the software solves this expression using a numerical substitution for T_{cal} and iterative binary search technique. The value of T_{cal} which provides the solution is then rounded up to the nearest whole second and compared to the user programmed minimum and maximum monitoring times.

The actual monitoring time (T_{mon}) used when monitoring is then set according to the following criteria:

$$T_{mon} = T_{cal} \quad \text{when } T_{cal} > T_{min}$$

$$T_{mon} = T_{min} \quad \text{when } T_{cal} \leq T_{min}$$

If $T_{cal} > T_{max}$ then a high background condition exists and monitoring is not possible. See [Notes regarding High Background \(page 5-96\)](#).

Minimum Detectable Activity (MDA) and High Background Criterion

Once a mean background count rate has been calculated, the PM12 will be ready to monitor users, and the Minimum Detectable Count Rate, also referred to as the detection limit (DL) is found by solving the following formula for DL:

Therefore $M_{Act} = \frac{DL}{Z_{Act} \cdot E}$,

$$DL = F \sqrt{\frac{B_{eff}}{t_B} + \frac{B_{eff}}{T_{mon}}} + P \sqrt{\frac{B_{eff}}{t_B} + \frac{B_{eff} + DL}{T_{mon}}} + \frac{1}{4} (F + P)^2 \left(\frac{1}{t_B} + \frac{1}{T_{mon}} \right)$$

where Act is the activity unit

Detectable Activity and Detection Limit may be viewed on the Information sub-menu (see [Information \(page 5-29\)](#)) and will be displayed in the units selected in the Options 1 sub-menu (see [Options 1 \(page 5-8\)](#)).

NOTE:

MDA may differ from the Alarm level because:

- Tmon is rounded up
 - Tmin may take effect
-

Changing Conditions

During the monitoring cycle, the monitoring time is subdivided into timeslices. Each sum of the count rates on all detectors in a slice is compared to the average count rate in the cycle up to that point.

Changing Conditions exist where the following formula is satisfied:

$$| [C_{av} - C_{sl}] | \geq N_{sl} \sqrt{C_{av}}$$

where C_{av} is the rolling average count rate within the monitoring cycle, up to the point of the check.

C_{sl} is the counts registered in the last time slice

N_{sl} is the Changing Conditions variable (see [Params 1 \(page 5-13\)](#)). It is not recommended that N_{sl} should be set below 3.0σ .

The first Changing Conditions check will take place after $2T_{sl}$ and then after every second within the monitoring cycle.

where T_{sl} is the Changing Conditions period (time slice) variable (see [Params 2 \(page 5-14\)](#)).

Contamination Alarm

After monitoring a user for the prescribed monitoring time (T_{mon}), the effective contamination alarm level (C_{effect}) is calculated as follows:

$$C_{effect} = C_{cps} - P \sqrt{\left(B_{eff} \left(\frac{1}{t_B} + \frac{1}{T_{MON}} \right) + \frac{C_{cps}}{T_{MON}} \right)}$$

The total system background count rate B_{eff} is then subtracted from the total system gross contamination count rate (C_{gross}), and the remaining (net) contamination count rate compared with the alarm level. So an alarm condition exists if:

$$(C_{gross} - B_{eff}) \geq C_{effect}$$

Calculation of Activity and Uncertainty

The system will display the level of radioactive contamination both on and in the user, and its associated uncertainty. Both of these options may be enabled from the Options 1 sub-menu (see [Options 1 \(page 5-8\)](#)). The Activity may be displayed after any measurement along with the associated detector/sum zone and body position, as long as the evaluated activity is greater than the MDA.

The activity is calculated using the following formula:

$$R_{Act} = Z_{Act} \cdot \frac{C_{gross} - B_{eff}}{E_{mix}}$$

where R_{Act} refers to the activity in the selected unit.

le nuclide mix, $E_{mix} = E_{nuc}$. However where the user has created a mix with multiple nuclides:

$$E_{mix} = \sum E_{nuc} \cdot P_{nuc}$$

where E_{nuc} is the efficiency of the system to a specific nuclide

P_{nuc} is the proportion of the specific nuclide within the total mix.

The uncertainty of the activity measurement is calculated as follows:

$$\frac{R_{Act} \cdot N_{conf}}{E_{mix}} \sqrt{\left(\frac{B_{eff}}{t_B} + \frac{C_{gross}}{T_{mon}} \right)}$$

where N_{conf} is the number of confidence levels.

Quickscan Quickscan is a method used to identify, within the monitoring time T_{mon} , whether the article is either "clearly" contaminated or clear, referred to as "real-dirty" or "real-clean". Quickscan is enabled on the Options 1 sub-menu (see [Options 1 \(page 5-8\)](#)). It is only activated when $T_{\text{mon}} > T_{\text{min}}$

The Quickscan period T_Q is the time period after the beginning of the monitoring cycle, at which the first time slice check is undertaken. Subsequently further Quickscan checks will be undertaken at periods that are integer multiples of T_Q e.g. $2T_Q$, $3T_Q$, until the end of the monitoring period. The Quickscan period is set on the Params 2 sub-menu (see [Params 2 \(page 5-14\)](#)).

If the Quickscan formula (refer to Thermo Fisher Scientific) is satisfied at any of the Quickscan checks, then the monitoring cycle will terminate, with the appropriate clean or contaminated indication.

Quick Background Quick background is a method that evaluates the shortest possible background monitoring time, while still satisfying the statistical criteria. Quick Background is enabled in [Options 1 \(page 5-8\)](#).

The formula used to evaluate the Calculated Monitoring Time (T_{cal}) is used. The system will re-evaluate the value of T_{cal} after every second of the background update, where the Background Update Time (t_B) is a variable. When the value of $T_{\text{cal}} < T_{\text{max}}$, then the system will return to service. Since the system acquires background counts at any time it is not in use, then the value of T_{cal} will reduce until a count rate from the previous 100 s has been acquired.

Cobalt 60 Window Monitoring A specific alarm for ^{60}Co contamination may be set, if enabled in the [Options 3 \(page 5-12\)](#). This alarm is based upon monitoring only those high energy photons which cannot be associated with radionuclides that emit lower energy photons, such as ^{137}Cs . Therefore it is also possible for other high energy photon emitters to be monitored using the ^{60}Co window.

The method of assessment of background count rates and contamination level, applies to the ^{60}Co window channel in the same way as for gross alarms described in this section. However both the background count rate B_{Co} and the efficiency E_{Co} , are considerably lower than for the gross sum channel.

Residual Contamination Level

After a measurement resulting in an Alarm condition, a Residual Contamination Count (RCC) may be taken, if enabled on the Options 1 sub-menu (see [Options 1 \(page 5-8\)](#)). A count equal to the monitoring time (T_{mon}) is enforced.

Residual Contamination is assumed to exist where the following formula is satisfied:

$$(C_{RCC} - B_{sum}) \geq N_{RCC} \sqrt{\left(\frac{B_{sum}}{T_{mon}}\right)}$$

where C_{RCC} is the average count rate during the Residual Contamination Count period.

N_{RCC} is the RCC threshold variable (see [Params 1 \(page 5-13\)](#)).

The default setting for N_{RCC} is 7.0σ and should never be set to a less than the sum of the probabilities of detection and false alarm ($P+F$).

In the event of residual contamination being detected, the PM12 will enter an "Out of Service" state and monitoring will not be possible (see [Notes regarding Residual Contamination Check \(page 5-92\)](#)). The doors will lock if the option is fitted. Intervention by a password holder will be required to terminate the fault status (see [Instrument Contaminated \(page 5-93\)](#)).

Automatic Calculation of Calibration Monitoring Time

The Calibration technique (see [Calibration Menu \(page 5-35\)](#)) uses flash (10 second) background and source counts to automatically calculate the count time for the user. The Calibration Accuracy and the associated confidence level are set in Params 2 menu (see [Params 2 \(page 5-14\)](#)).

The count confidence level has a default setting of 3σ (99.7%) which is a generally accepted Confidence level that produces acceptable count times.

Then Calibration Count Time,

where $N_{conf} = 3$ (Count Confidence Level of 99.7%)

n = Flash source + background Count (cps)

b = Flash Background Count (cps)

A = Calibration Accuracy (ratio e.g. 5% = 0.05)

The calculated count time is rounded up to the nearest whole second and T is limited to 10,000 seconds.

$$T = N_{conf}^2 \frac{(n + \sqrt{nb})}{A^2(n - b)^2} (Sec's) .$$

Isotope gamma efficiencies

The following data were obtained during type testing in a stable 7-10 $\mu\text{R/h}$ (0.07-0.1 $\mu\text{Sv/h}$). Background using point-sources in free space, (i.e. un-attenuated). The detectors were optimised for each Isotope in the geometric centre of the measurement cubicle.

Efficiencies are quoted Centroid (geometric centre of Portal) and 3 inches from a typical detector. Note that 3 inches is often used as a datum for contact efficiency measurements, since it is assumed to be the distance of contamination from an individual detector.

PM12 – Standard with aluminium door panels

Table 5 PM12 with 1" of Lead Shielding Centroid efficiencies

Position	Typ. Background Count Rate (cps) in 10 $\mu\text{R/h}$ (0.1 $\mu\text{Sv/h}$)	⁶⁰ Co (1.2 MeV)	¹³⁷ Cs (662 keV)	¹³⁷ Ba (356 keV)
Centroid	6000	17.1 %	8.6 %	4.6 %
Foot (contact)	950	36 %	19 %	14 %
Head (contact)	750	36 %	17 %	6.2 %
Body (3 inches)	850	21 %	11 %	6.5 %

A full Type Test Report is available from Thermo Fisher Scientific on request.

Probability – Sigma and %

Table 6- Probability - Sigma and %

Sigma	Probability
0.0	50.00%
0.1	53.98%
0.2	57.93%
0.3	61.79%
0.4	65.54%
0.5	69.15%
0.6	72.57%
0.7	75.80%
0.8	78.81%
0.9	81.59%
1.0	84.13%

Sigma	Probability
1.1	86.43%
1.2	88.49%
1.3	90.32%
1.4	91.92%
1.5	93.32%
1.6	94.52%
1.7	95.54%
1.8	96.41%
1.9	97.13%
2.0	97.72%
2.1	98.21%
2.2	98.61%
2.3	98.93%
2.4	99.18%
2.5	99.38%
2.6	99.53%
2.7	99.65%
2.8	99.74%
2.9	99.81%
3.0	99.87%
3.1	99.90%
3.2	99.93%
3.3	99.95%
3.4	99.966%
3.5	99.977%
3.6	99.984%
3.7	99.989%
3.8	99.993%
3.9	99.995%
4.0	99.997%

This probability refers to either the Probability of Detection or the Probability of NOT triggering a False Alarm. These probabilities are calculated and displayed in [Params 2 \(page 5-14\)](#).

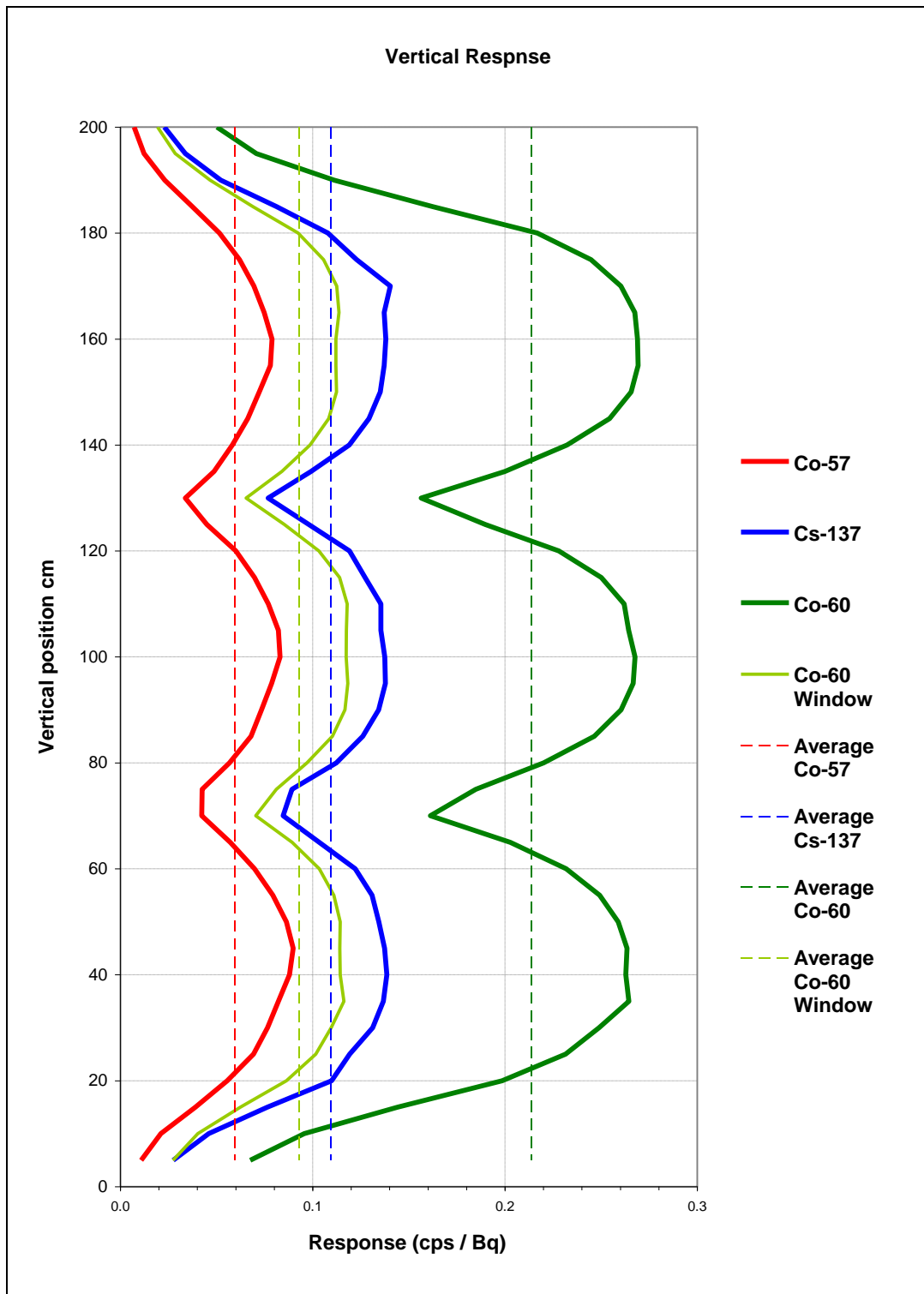

Figure 4 Variation in the Vertical Plane

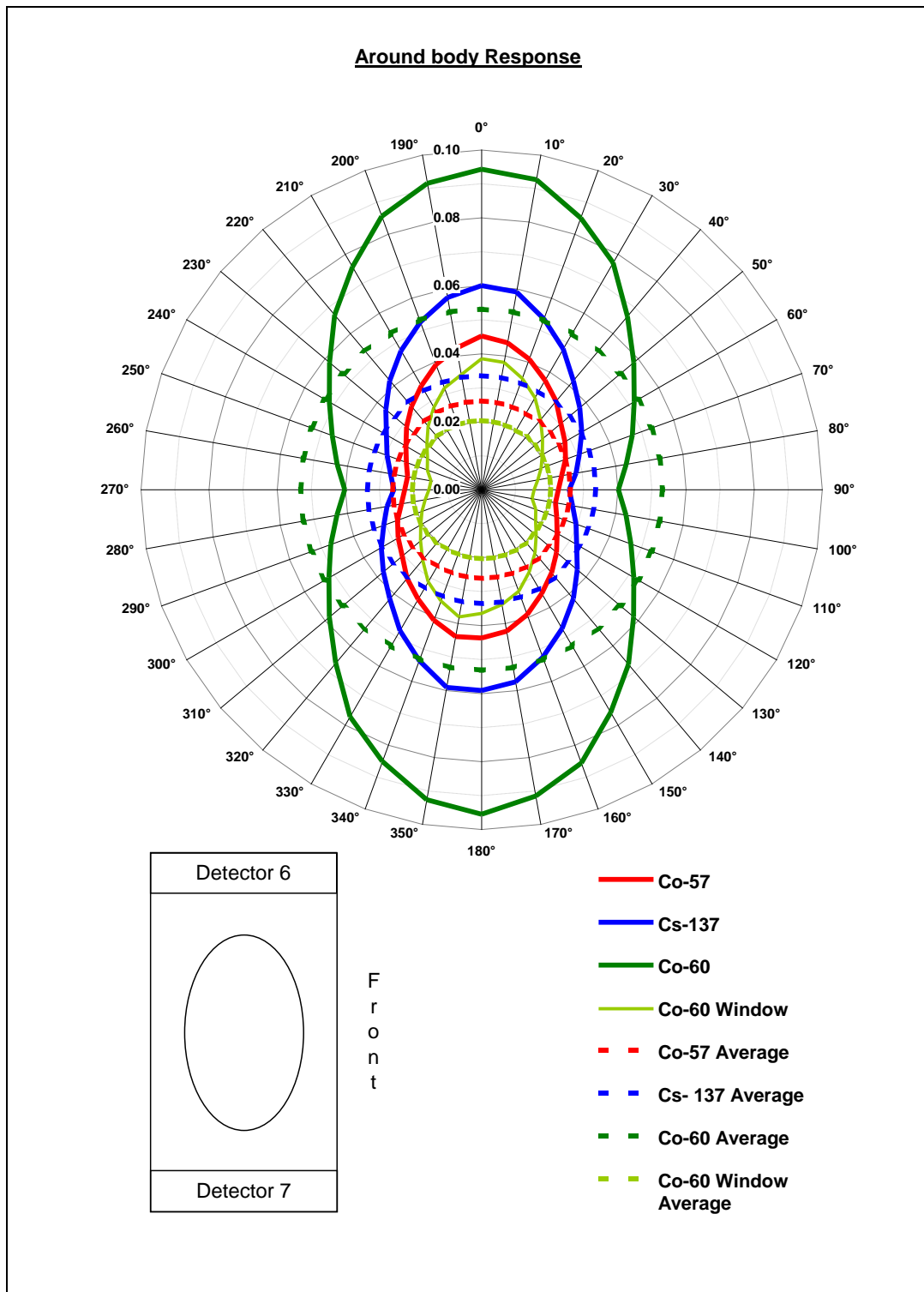

Figure 5 Variation in response around the Body – horizontal plane

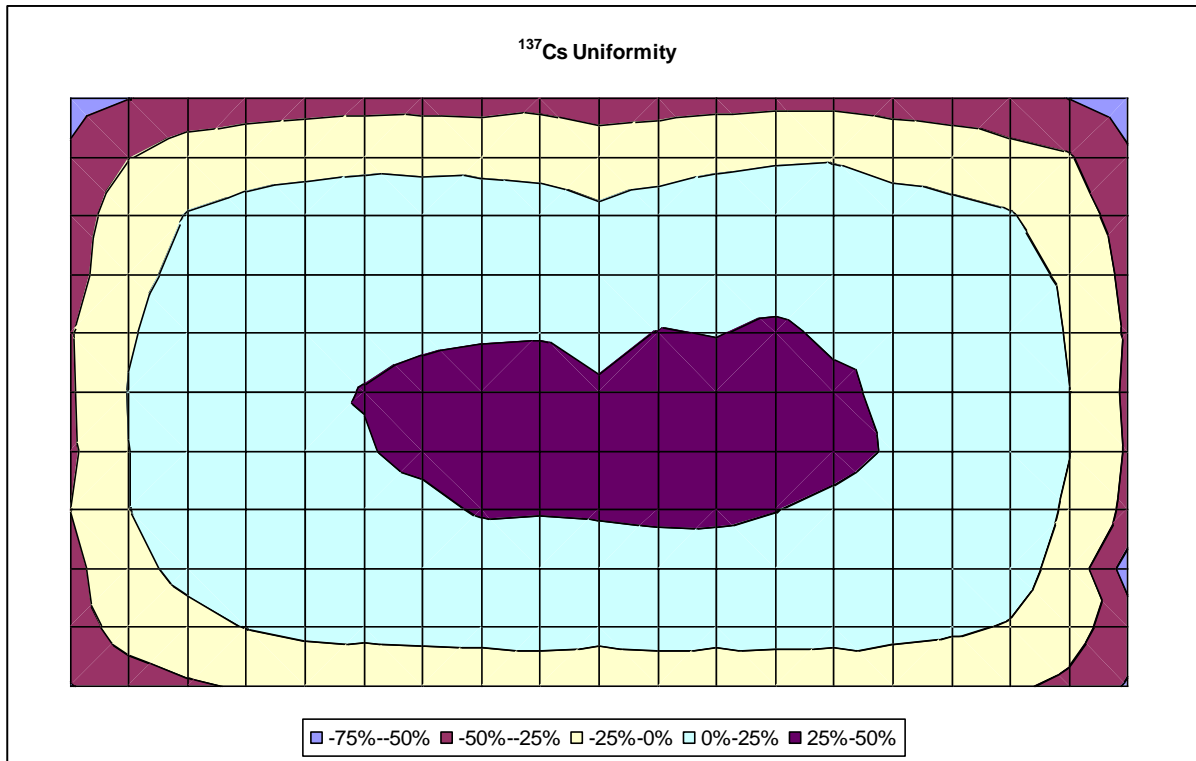

Figure 6 Foot detector uniformity to 137Cs

Chapter 7 Technical Description - Circuitry

[Description \(page 2-1\)](#) provides a general background to the following description and should be read before proceeding.

Introduction

This section deals with the operation and function of all the major electronic assemblies which comprise the PM12. Description of all assemblies is restricted to general operation and specification since detailed circuit operation may be the subject of design confidentiality.

Reference to GA 11705190 will reveal the interconnection between the following modules:

1. Electronic Chassis Assembly 11705181 (see [Electronic Chassis 11705181 \(page 7-2\)](#) and [Electronics Chassis Type 11705181 \(page 2-2\)](#))

The processing centre for the PM12 which includes the power management circuitry.

2. Scintillation HV & Amplifier assembly 11705186 (see [Scintillation HV and Amplifier Type 42543-0223 used in Assembly 11705186 \(page 2-4\)](#))
3. Annunciator assembly 11705182A/B (see [Annunciator Assembly 11705182A/B \(page 7-7\)](#))
4. Sensor assemblies and interconnection 11705235A/B (see [Sensor Assembly 11705235/A & B and Connect Card 5697A \(page 7-7\)](#))
5. Detector assemblies 5678A
6. Display assembly 11705210 (see [LCD Display and Controller I/F & Backlight Inverter Module \(Assembly 11705210\) \(page 7-9\)](#))

Reference to GA 11705325 (PM12C only) will reveal the interconnection between the following modules:

1. Power door interface 5707A
2. Barrier Mechanism 702847JB
3. Folding Doors Controller 11705326
4. PM12 X-channel and power

Electronic Chassis 11705181

The majority of the electronics is contained on board this sub-structure allowing easy removal for servicing.

The assembly contains the following modules:

1. Controller card 5691A (see [Controller Board Pair - Types 5691A and 5694A \(page 7-2\)](#))
2. Disk drive A92083/A
3. I/O Expansion card 5694A (see [Controller Board Pair - Types 5691A and 5694A \(page 7-2\)](#))
4. Battery controller 5660A (see [Battery Controller Board Type 5660A \(page 2-3\)](#))
5. DC-DC converter 5675A (see [DC-DC Converter Board Type 5675A \(page 2-4\)](#))

Controller Board Pair - Types 5691A and 5694A

The Controller Board pair comprises all the interface buffers and connections necessary to communicate between all peripherals and the proprietary on-board plug-in ETX processor. The assembly is constructed from two cards, namely the 5694A & 5691A, which are interconnected by PL11/SK11 in order to achieve a slim-line geometry for the PM12 corner frame.

ETX Processor

The ETX unit plugs into the motherboard 5691A using connectors SK2, SK5, SK9 and SK12.

The assembly has the following facilities used by the system:

1. 800Mhz Pentium-M processor.
2. 256 megabytes of RAM.
3. Dual RS232 Serial communication interface.
4. Real time clock.
5. This is supported by an off-board Lithium battery. The RTC provides microprocessor access to year, month, day, hour, minute, seconds. It also provides several interrupt periods from one year down to 0.01 seconds
6. Quad USB hub Type 1
7. Single Ethernet interface
8. LCD and CRT drivers
9. Dual IDE ports

10. ISA 8-bit I/O expansion to 5694A

11. Flash Card interface

12. Audio synthesizer

Summary of 5691A Functions

Function	Source	Destination	Comments
VGA/CRT	SK9		display interface available for diagnostics
LCD drive	PL5	Display 11705210	LVDS cable
LED Power/control	IC10/11		5691A
Backlight	PL9	Display 11705210	Fixed intensity
Serial drivers	IC1/2		
Touch control	PL1	Display 11705210	RS232 interface
USB power controllers	IC3/4		5691A Provides for two independent power sources with current limiting for USB peripherals
USB	SK1/2	Display 11705210	5691A extension from SK5/6/7/8
LoudSpeaker driver	IC5		5691A
Loudspeaker	PL3	Mainframe	loud-speaker drive from the on board (ETX) sound generator
Keyboard & Mouse	PL4		5691A
Primary IDE	PL23	Electronic chassis 11705181	44 pin /2.5" Disk Interface
Secondary IDE	PL14		40 pin /CD Rom Interface
Flash Interface	PL12	Compact Flash	Installed Link 4 selects Master Status (normally jumpered as a Master)
ISA	SK11	5694A	Expansion I/O
Power	PL13		5691A

IC1 & IC2 provide for RS232 voltage levels on PL1 & PL2 as follows:

Label	Connection PL1/2	Function
TXD	5	Transmit Data
RX-EXT	3	Receive Data
DTR	7	Data Terminal Ready
RTS	4	Ready to Send
DCD	1	Data Carrier Detected
CTS	6	Clear to Send
RI	8	
DSR	2	Data Set Ready

I/O Expansion Card 5694A

IC2 is a Programmable Logic Device (PLD) providing the following:

1. Control of X-channel power switching by RL1
2. 8 x optically isolated sense inputs on PL13 & PL14
3. Routing signals for Dual serial device IC4
4. A watchdog output for 5691A
5. Routing signals for I²C communication device IC1

Expansion Card Inputs and Outputs

Input/Output	Connection	Function
IP0	PL13 pin 2(+) & PL13 pin 3 (-)	Left hand sensor interconnect
IP1	PL13 pin 4(+) & PL13 pin 5 (-)	
IP2	PL13 pin 6(+) & PL13 pin 7 (-)	
IP3	PL13 pin 8(+) & PL13 pin 9 (-)	
IP4	PL14 pin 2(+) & PL14 pin 3 (-)	Right hand sensor interconnect
IP5	PL14 pin 4(+) & PL14 pin 5 (-)	
IP6	PL14 pin 6(+) & PL14 pin 7 (-)	
IP7	PL14 pin 8(+) & PL14 pin 9 (-)	
I ² C Buffered	PL2 / 10 way Header	IC3 provides necessary buffering for IC1 output
I ² C UN-Buffered	PL1 / 6 way Header	IC1 output is available directly
X-channel/A/5660A	PL5 5way MTA	Battery controller comms

X-channel/A/ FHT681s	PL6/10 way IDC	Current limited supply available
X-channel/A	PL4/ RJ45	IC5 provides RS422 buffering for IC4 For X-channel cards 5621,5622 and 5623
X-channel/B/ 5660A	PL8 5way MTA	Battery controller comms
X-channel/B/ FHT681s	PL9/10 way IDC	Current limited supply available
X-channel/B	PL7/ RJ45	IC5 provides RS422 buffering for IC4 For X-channel cards 5621,5622 and 5623

PM12C GPIO Controller Card 5707A

This is an X-channel device which enables the operating system to monitor and control the "power doors" and "barrier arm". Up to eight isolated inputs and outputs are available.

Input/Output	Connection	Function
IP4	PL08 pin 1 & PL08 pin 2	Rekord Door CLOSED status
IP5	PL08 pin 3 & PL08 pin 4	Rekord Door OPEN status
IP0	PL09 pin 1 & PL09 pin 2	Barrier status DOWN
IP1	PL09 pin 3 & PL09 pin 4	Barrier status UP
RELAY 1	PL4 pin 2	Barrier drive -
RELAY 2	PL4 pin 5	Barrier drive +
RELAY 4	PL5 pin 2 & PL5 pin 3	Rekord door control OPEN/CLOSED
INTERLOCK	PL13 pin 4 & PL13 pin 5	Emergency OPEN
POWER	PL1 pin 1 & PL1 pin 2	Barrier power + Barrier power -
X-channel/A/ FHT681s	PL6/10 way IDC	Current limited supply available

Battery Controller Board Type 5660A

This is an X-channel device which enables the operating system to monitor the charging process and remotely shut down the load.

The Battery Controller Board, type 5660A, controls the DC voltage output of a power converter unit (PL4) between the range +11.2 V to +15.6 V in order to maintain the integrity of the +12 V 15 Ah Lead Acid Battery (PL3), over the operating temperature range (temperature sensor on PL1).

The 5660A has the ability to switch the load (PL6) ON/OFF as directed by the operator, whilst continuing to charge the battery. Current and voltage monitoring (IC100/101) and control circuitry (IC4) always ensure sufficient power is made available to power the PM12 (even when the battery is exhausted) from the primary power source.

The transfer to battery is automatic. However the load will be removed when the battery terminal voltage falls below +10.5 V. This circuit is required to prevent the battery being damaged by being deeply discharged. Hysteresis is built in to this circuit to prevent oscillations. It does not allow the battery to re-connect as soon as its terminal voltage recovers slightly as a result of having the load removed from its terminals.

The user is signalled the pending shut-down in order that any data can be saved.

A key switch is connected to the 5660A for manually switching the power ON/OFF to the load.

Keyswitch Operation

The key-switch performs two operations.

Primarily it allows the instrument to be switched ON if either the mains supply exists or the battery contains sufficient charge, or both. This is achieved by turning the key clockwise for at least 2 seconds.

Secondly, the instrument can be switched OFF should the operating software fail to carry out the "Shut-down" task by holding the key clockwise for at least 10 seconds.

**Annunciator Assembly
11705182A/B**

The I²C bus (on PL2) is used to communicate with the two cards 5672A & 5700A which are essentially arrays of LED devices organized in clusters for lamps or man-mimic display. A dual character seven segment display records any count down. The front and rear assemblies are independently addressed.

**Sensor Assembly
11705235/A & B and
Connect Card 5697A**

Six infra-red links are established from assemblies placed near the mid point of the four corner members of the PM12 frame. The front arrays are linked to the front connect card 5697A located in the left hand column and the rear arrays are similarly linked to the rear connect card 5697A in the right-hand column. Four status signals (one belonging with the annunciator push-switch) are returned from each connect board (PL1) to the isolated inputs on the 5694A on PL13/14.

**FHT681 Scintillation HV &
Amplifier**

The Dual-Channel Scintillation HV and Amplifier board provides the high voltages for two scintillation detectors. It also receives charge pulses from two detectors, amplifies them and discriminates between five energy levels. Independent counter values (five for each channel) are generated every 100ms and stored in a 5 second buffer. In addition to that, 1s values are built from the 100ms values. All these values can be polled from the serial interface.

**HV & Amplifier
Connections**

The HV sections are designed to provide independently adjustable polarising voltages for two scintillation detectors with working voltage ranges between 500V to 1400V.

The setting of high voltages and thresholds is done via the serial interface.

The 1st, 3rd and 4th counters for each channel form Cobalt coincidence pulses which are available on OUT1 & 2 connectors.

The card has six connectors.

PMT1 & 2 The scintillation detectors are connected via MHV connectors.

OUT1 & 2 Coincident outputs are on BNC connectors

X15 & X16: These connectors provide power supplies to the board and RS485 terminations:

X15 & X16	SIGNAL
1	EARTH
2	0V
3	RX-
4	TX-
5	Signal Ground
6	TX+
7	+5V
8	RX+
9	+5V

Modules 11705186

For more information regarding the Scintillation HV and Amplifier Board, see [Scintillation HV and Amplifier Type 42543-0223 used in Assembly 11705186 \(page 2-4\)](#).

Mains Power Module (Assembly 11705184)

The mains power supply is a proprietary high-frequency switched mode 50 Watt converter. The power module can accept a mains input of 85 V to 264 V, 47 Hz to 63 Hz, the output is between 12 and 15 V at 3.5 A. The actual output voltage is controlled remotely by the 5660A.

The power supply is capable of charging the battery at a maximum rate of 3.3 A, up to +40°C. This module contains AC Mains and dangerous DC switching voltages. It should not be operated with the protective cover removed or the mains ground (earth) conductor disconnected. It is not user serviceable and should be returned to Thermo Fisher’s Service department for repair.

An additional AC spur is provided on the PM12C power unit for driving the Folding Doors.

LCD Display and Controller I/F & Backlight Inverter Module (Assembly 11705210)

The LCD module is fitted with an integral Cold Cathode Fluorescent (CCFL) back-light (which is replaceable if found faulty). The back-light is driven from a proprietary inverter (part of 11705188), mounted in a small screened box within the display. The inverter generates dangerous high voltages and RF interference frequencies and should not be operated outside the box or with the display lid removed.

The LCD is controlled via a proprietary serial interface device (part of 11705188) also mounted in a small screened box within the display.

Two USB sockets are provided on the base of the assembly.

Neither the display or the back-light inverter or the controller are user serviceable and should be returned to Thermo Fisher's Service department for repair.

General Electromagnetic Compatibility (EMC) Considerations

The overall construction is designed to minimise the effects of mains and airborne interference and emissions.

It is, therefore, vital that the construction standard is maintained at all times, particularly when replacing parts and during servicing.

Earthing is particularly important for continued EMC (and Safety) performance. 'Hard' earthing of the mains inlet/filter assembly and LCD display tail, the HV/Amplifier 11705186 screening can and the frame earth are particularly important. Refer to the relevant Servicing instructions in [Routine Checks \(page 8-1\)](#) for details.

The instrument should only be operated with all earthing connections securely made and all screening covers fitted.

Chapter 8 Routine Checks

This section describes the routine checks required to ensure the correct operation of the PM12. Most mechanical and electronic failures, if they occur, will become apparent during normal operation and do not require checking. Therefore, they are not included in this section.

Mechanical Checks

PM12 Mounting Arrangement

During calibration, or more frequently if required, check any mechanical structure on which the PM12 may be mounted. Since the PM12 with especially with 1" of lead shielding is very heavy, any mounting arrangement should be inspected for signs of deterioration, instability or any other factor which may affect safety of operation or maintenance. If any such defect is suspected, the PM12 should be withdrawn from service and safely removed using a suitable forklift and the integral fork lifting facilities provided. The mounting should be repaired and made safe before replacing the PM12.

Other Mechanical Checks

Any other mechanical faults should, if they occur, become apparent during normal monitoring operation.

If the PM12 is used frequently by personnel with wet/snow covered boots regular checks should be made on the drainage holes in the bottom section of the frame. This will require the removal of the foot plate, its detector and associated lead.

Electrical Checks

Battery Charge state

During calibration, check the general condition of the battery. To do this, turn the PM12 ON by rotating the key-switch on the front panel to the ON position. Remove the mains power cord. Remove the bolts retaining the main corner section (you will need to remove the associated inner panel to gain access to the bolt heads) and locate PL3 on controller card 5660A. Connect a suitable Voltmeter, set to the DC volts range, directly across the terminals of PL3. Check the "load" battery voltage is greater than 12 volts (assuming the battery has previously been charged). If the battery voltage is low, consult [Troubleshooting \(Operational\)](#) (page 11-18). Replace the top cover.

Alternatively the battery voltage and load can be monitored from within the application (see [Battery \(page 5-20\)](#) for further information).

NOTE: Only qualified personnel should operate the PM12 with the mains connected and the top cover removed. Make sure all the warnings given at the front of this manual are heeded.

Display Checks

During calibration, ensure all lamps are operational (see [Sensors \(page 5-33\)](#) for further information).

It may be necessary at some time (due to replacement of Touch Screen or Touch Controller) to re-calibrate the touch screen. This is an Administration function and the facility would be accessed outside of the application program.

EMC & Safety Earthing Checks

Periodically, and after Servicing, check all Earth connections are fitted and tight to ensure continued EMC performance and User Safety. These checks should include the screws securing the mains inlet/filter assembly in the top chassis, all connections to the central earth point (CEP), and the connection to the Main and corner frames.

Also check that all screening covers are fitted and all fixings tightly secured.

Periodic Source Checks

During calibration, after repairs, or once a year, the detection efficiency of the PM12 should be checked using a Calibration check as described in [Cal Check \(page 5-35\)](#). To perform these checks, small area sources of the nuclides that the PM12 is required to detect should be used. A stable background is essential for an accurate result. The calibration check will be performed to an accuracy defined by Calibration Check Accuracy (%) (see [Params 1 \(page 5-13\)](#)). The overall Efficiency calibration factor should be within $\pm 10\%$ of the existing programmed value.

Should the results be outside these limits, the PM12 operational parameters require revision (see [Setting Up Procedure \(page 9-1\)](#)). Calibration procedures are described in [Calibration Procedure \(page 10-1\)](#).

Carry out a regular source check after a 100 sec background update.

Regular Source checks

Daily or weekly source checks are advisable, using a Calibration check as described in [Cal Check \(page 5-35\)](#).

For detector calibration, the check source needs to be placed in calibration positions coinciding with the geometric centre of all detectors.

An alternative is to undertake an [Alarm Check \(page 5-32\)](#) where a source of activity marginally greater than alarm level setting should be held against each detector in turn. Each detector should alarm within the typical monitoring time.

Cleaning Instructions

WARNING: Ensure the mains supply is isolated before cleaning.

The display can be wiped clean with a dry cloth. Smudges may require the application of the Screen cleaner provided when the instrument was delivered.

The cubical should be cleaned using a mild detergent.

Make sure the equipment is completely dry before re-connecting the supply.

Chapter 9 Setting Up Procedure

Initial Setting Up for Use

General After the initial installation and before switching on the PM12, read [Operating Instructions \(page 5-1\)](#). Connect the mains lead to the PM12 and turn the keyswitch clockwise until the unit switches on (a click is heard after about 1-2 seconds) and then release it (see [Keyswitch operation \(page 7-6\)](#)).

Initialisation The PM12 will power up and load up the Windows XP operating system, followed by the PM12 application. During this time, the *Thermo Scientific* banner will be displayed (see below).

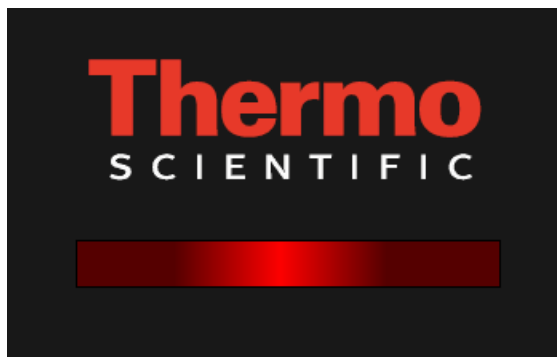

Once the application has loaded, the application will initialise (see [Start Up Checks \(page 5-72\)](#)). The system will automatically pass into the User Mode. In this mode, the user will not have access to any operational parameters. In order to set up the instrument the user requires a security dongle, which should be placed in the USB port of the PM12. When this dongle is in place, the touch screen is activated, and the user will have access to the [Administrator Mode \(page 5-1\)](#).

Setting Passwords There are three user levels: Technician, Health Physicist and Thermo Fisher. The lowest level is *Technician* and allows the user to view some parameters and undertake calibration checks. The *Health Physicist* level gives access to all parameters that are used for calibration and setup of the instrument. The top level *Thermo Fisher* is reserved for the expert user since it gives access to specialised calibrations settings that fundamentally affect the performance of the instrument, and should only be set at the Thermo Fisher factory or by a Service

engineer. See [Passwords \(page 5-67\)](#) for details regarding the default passwords. The menu options that are available to each user levels are summarised in [Menu Roles \(page 5-6\)](#).

[Passwords \(page 5-67\)](#) show how the user may change the password. Both the *Thermo Fisher* and the *Health Physicist* passwords protect the security of the operational Parameters and hence the integrity of the measurement. Therefore these passwords should remain confidential; their use restricted and above all should not be readily obvious to potential "hackers".

Each user level should have a unique password and under no circumstances should all three levels be assigned the same password.

Setting the Operational Parameters

At this point, it is strongly recommended that the following User Programmable Operational Parameters are checked and reset by the Health Physicist before allowing normal monitoring to proceed.

Low Background Alarm
High Background Alarm
Calibration Required Interval

See Set-Up|[Params 1 \(page 5-13\)](#) for more information.

Minimum Monitoring Time
Maximum Monitoring Time
Quick Scan Period
Probability of Detection
Probability of False Alarm
Measurement Confidence
Gross changing background
Detector changing background
Changing Conditions
Changing Conditions period

See Set-Up|[Params 2 \(page 5-14\)](#) for more information.

Calibration stream
Normal Alarm

See Set-Up|[Alarms \(page 5-18\)](#) for more information.

Resetting the above Parameters will guarantee the integrity of measurements. It is also important to reset the time and data (see [Setup \(page 5-66\)](#)) since these are used when check the calibration due dates, and also by the Data option.

A listing of all the parameters is available by selecting [Configuration Report \(page 5-54\)](#). This report should be either printed or saved to USB memory stick, when the instrument is first set up, and when significant changes of configuration are undertaken.

The PM12 will be delivered optimised with a valid HV Scan and optimum operating voltages stored. If the HV Scan needs to be undertaken for any reason, follow the procedure described in [HV Scan \(page 5-41\)](#).

The details of the current and previous calibrations are stored to a backup compact flash. These backups take place automatically after every calibration, and when requested by the User. It is recommended that the backup is undertaken after every voltage scan and calibration. This backup may be retrieved if for any reason the hard drive on the instrument needs replacement.

Selection of Detector Operating Parameters

The following sections assume that the instrument is set to the factory defaults.

Detector HV Selection

The Test and Performance Certificate supplied with each instrument lists the recommended High Voltage settings for each detector for the optimum detection. [HV Scan \(page 5-41\)](#) describes the setting of the detector HVs.

If, however, it is required to ascertain the optimum operating voltages by measurement, e.g. due to new detectors, the procedure described in [Derivation of the Optimum Operating Voltage \(page 9-3\)](#) should be followed. Calibration for other nuclides and nuclide mixes is described in [Calibration Procedure \(page 10-1\)](#).

Derivation of the Optimum Operating Voltage

The PM12 is designed to detect activities down to release levels and otherwise 'as low reasonably achievable'. However, the PM12 is also very linear in response, so a wide range of source activities may be used for set-up and calibration. Depending upon energy / detector efficiency, source activity should ideally be in the 5 μCi (185 kBq) to 11 μCi (400 kBq) range, and in any case not more than 20 μCi (740 kBq). Long count times will be required for small sources to maintain statistical accuracy against adverse background influences.

Performing the HV Scan

NOTE: For all the measurements performed below, all sources of radiation other than that used for the specific test, should be removed from the immediate area in order to minimise the effect of background fluctuations. All counts read from the detectors are corrected to compensate for the amplifier "dead time".

With the PM12 and surrounding area free of sources, enter the [Administrator Mode \(page 5-1\)](#) as 'Health Physicist'. From the function tabs on the left side of the screen select the 'Calibration' option. Then from the tabs along the top of the screen select 'HV Scan'. There will be a choice between performing a 'New Scan' and viewing the 'Last Scan'. Press the 'New Scan' button.

The new screen allows for the setting of the scan parameters Start, Stop and Step voltages as well as the counting time. The recommended values for these parameters are;

Start	=	600 volts
Stop	=	1100 volts
Step	=	5 volts
Time	=	10 seconds

NOTE: Short voltage steps are required in order to make the location of the optimum operating voltage easier. Using the recommended values, this process will take approximately one hour to complete.

Once there parameters have been set and the 'Start' button has been pressed. A series of onscreen instructions are displayed to step the user through the scan process.

NOTE: The scan can be aborted at any time by pressing the 'Abort' button. The background scan is performed on all detectors simultaneously.

The first step is to perform a background scan. This is followed by a scan with a ^{137}Cs source. The user has the option of selecting which detectors to scan. The quickest method is to place the source in the centre of the portal and scan all the detectors simultaneously. An alternative method is to scan the detectors in three phases: first place the source midway between 6 and 7, and select detectors 6, 7 and 8 for scanning; then place the source between detectors 4 and 5 and select the same detectors for scanning; then place the source between detectors 2 and 3, and select detectors 1, 2 and 3 for scanning. Another alternative method is scan each detector individually,

with the source in close proximity to the centre of each detector, i.e. 3 inches (7.5 cm).

Thermo Fisher believe the optimum method is the second, since this method ensures the source is in close proximity to the detectors being scanned, whilst minimizing overall test time.

On completion of the scan, the user is given the option of saving the data by pressing the 'Save Scan' button. This data, along with its description, can be retrieved via the 'Data' tab (see [HV Scan Report \(page 5-59\)](#)). Once the 'Save' button has been pressed, the display changes to show graphs of the scans.

Determining the operating voltage for mid-high energy nuclides

There are two methods for determining the optimum operating voltage depending on whether the low energy alarm will be used, or whether the voltages will be set the "classic" way by reviewing the Figure of Merit at each voltage setting. The recommended method is known as the NBR method, which typically will also provide an operating voltage which satisfies the Figure of Merit criteria. The NBR method must be used if the ^{60}Co window or low energy indications are enabled. The NBR method requires the use of a ^{137}Cs calibration source for voltage optimisation.

NBR method

When the graph of the voltage plots is displayed, press the detector on the screen mimic, and the respective graph for a detector which will expand it to fill the screen. Select the NBR button, and a ratio against operating voltage graph is displayed. The optimum operating voltage is that which has a T1/T2 ratio of between 30 and 35. In order to find this press the 'Table' button and the data will be displayed. From the table, identify the operating voltage that has the correct T1/T2. If you have to interpolate between two voltages, assume a linear change. Enter this value into the 'HV Setting' box and then press the 'Back' button.

The value below the graph will now have a **Gold** background to it. This background colour highlights that the value has been changed, but not yet saved. When all operating voltages have been set, press the 'Apply Settings' button to save these values.

NOTE: The 'Back' button **must** be pressed in order to access the other functions.

Figure of Merit (FOM) method

NOTE: The following procedure tends to be iterative in nature and included as a guide only. Different operational requirements and background conditions may necessitate a different choice of operating point. The final choice should be at the discretion of the senior Health Physicist.

The Objectives are to:

- Obtain consistent detector efficiencies, particularly between opposite pairs, and
- Obtain good overall system efficiency, and
- Obtain low average background count and minimal spread between detectors

When the graphs are displayed, select the ‘Gross Counting’ option, and then press the respective graph for a detector which will expand it to fill the screen. Pressing ‘Table’ will show the actual FOM and S^2/B values – note that S^2/B is proportional to FOM and is included for those users who prefer this quantity.

For mid and high energies, an FOM ‘peak’ is usually evident from the data. Determine the maximum value of FOM for each detector - **as a starting point**. If no clear peak is visible or several peaks exist, select a starting FOM value corresponding to a background value (B) similar to that of the other detectors. Select the detector operating point as follows:

1. Each background count does not differ by more than 30% from the mean value of all detectors.
2. When the source to detector distance is the same, calculate the Mean Source Counts (S_m) for all detectors. The value of the net source counts (S) for each detector does not differ by more than 25% from the mean value of (S_m) for all.

If any detector exceeds any of these limits, alter the relevant HV by 10 V and check the FOM is not significantly different than the original. A total adjustment of 75 V is permissible.

This is a rough guide and individual circumstances may demand wider variations.

If and when the background and source values are satisfactory, calculate the detector efficiencies, at the chosen HV setting. Calculate the overall system efficiency, which should be within the range below:

⁶⁰ Co (1.2 MeV)	¹³⁷ Cs (662 keV)
Centre	Centre
17% (15-19)	8% (6.5-9.5)

If the overall system efficiency or any individual detector efficiency is too low (or too high), consider the efficiency values at the next HV step - review the background Criteria in Tests (1) & (2) and the Source Criteria in Test (3). Repeat this process if necessary.

NOTE: The Minimum Detectable Activity (MDA) is proportional to the square root of the Background – lower background improves (reduces) the MDA. Therefore ‘Squeezing’ a few extra source counts at the expense of a significant background increase, will be detrimental.

Variance Testing

When the system has been set-up, a background stability test, usually referred to as a variance test, should be performed. This is a test to measure the deviation of the distribution of background from a perfect Gaussian distribution. This is equivalent to a Chi-squared test.

See [Variance Test \(page 5-30\)](#) for further information regarding how to set up the variance test. The variance test result is the variance of the counts recorded in each cycle, divided by the mean count in all the cycles. The upper and lower variance limits have defaults of 1.5 and 0.67. These values are always the reciprocal of each other. The default values are based on a recommended number of counting cycles of 25 and a cycle period of 25 s. If the number of cycles or the counting period is increased above these values, then the spread of values is lower, and the limits may be reduced. Refer to Figure 7 Statistical Limits of Counter Reliability ([page 9-8](#)) for typical limits.

STATISTICAL LIMITS OF COUNTER RELIABILITY

P represents the probability that the observations show a greater deviation from the Poisson distribution than would be expected from chance alone.

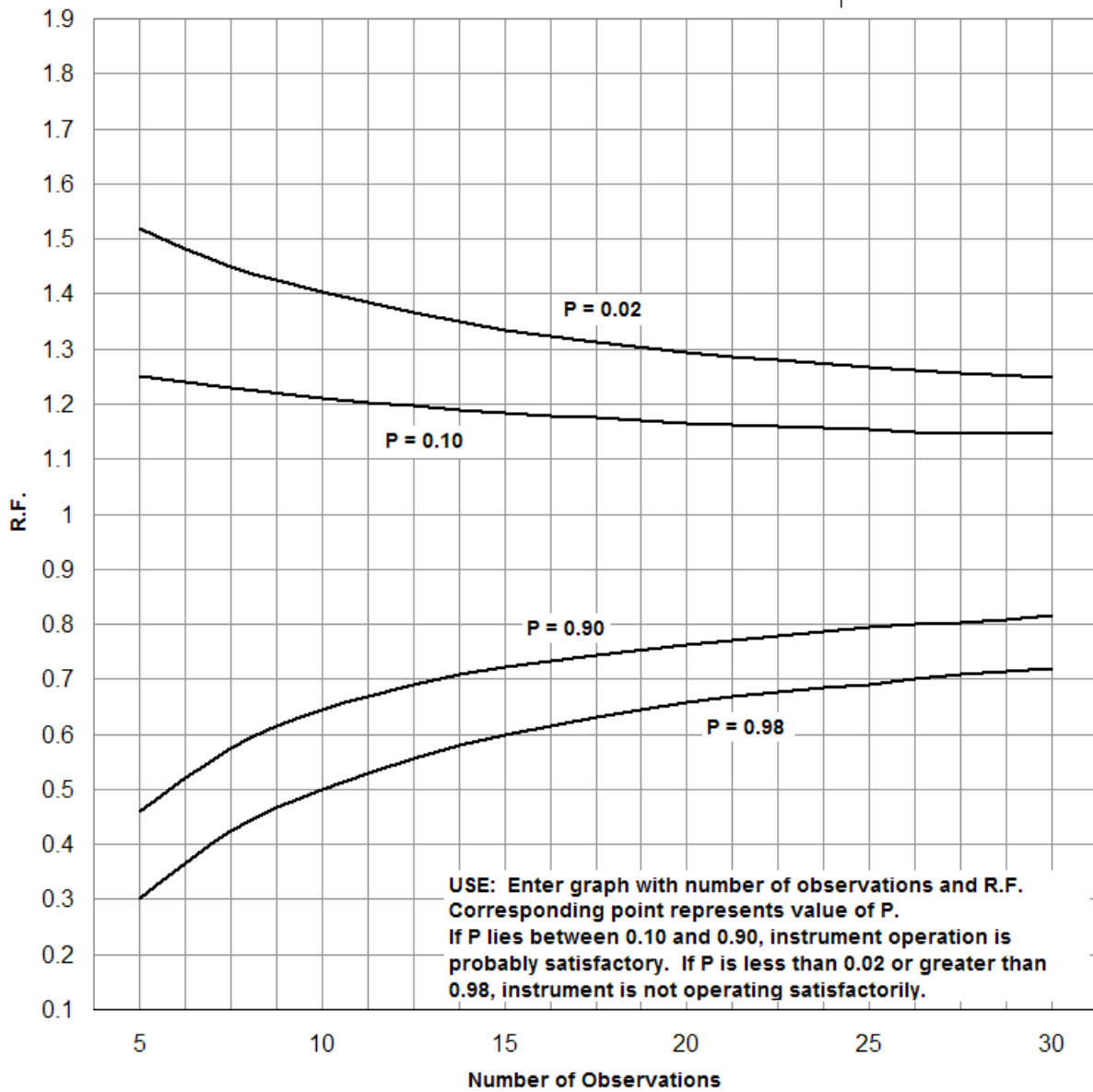

Figure 7 Statistical Limits of Counter Reliability

Chapter 10 Calibration Procedure

This section deals in detail with primary system calibration. It includes background, source and efficiency checks on individual detectors to check detector balance as well as overall system efficiency. Primary system calibration by the Health Physicist is only usually necessary on initial installation and on a periodic audit basis. More frequent overall system calibration checks can be quickly carried out by Technician user level using the "Cal Check" facility (see [Cal Check \(page 5-35\)](#)). For more information regarding the user roles, see [Foreword \(page xv\)](#) and [Menu Roles \(page 5-6\)](#).

Note: Throughout this section examples are given in Bq. However, by first selecting nCi's from the Options 1 Menu (see [Options 1 \(page 5-8\)](#)) as the operating units, all values may be entered in these units. Of course the equations remain unchanged, though care must be taken to ensure that the units are consistent.

Calibration Validity

The PM12 is capable of undertaking a calibration validity check. This check will evaluate the number of days between the last valid (PASS) calibration check. If this number of days exceeds the maximum acceptable recalibration interval, then the PM12 will put itself "Out of Service" (see [Out of Service \(page 5-94\)](#)).

To define the period between calibrations checks, set the "Calibration Required Interval" parameter in [Params 1 \(page 5-13\)](#).

If the user "Fails" the calibration check, then this is not treated as a calibration, and is disregarded when assessing whether the PM12 is within its recalibration interval.

Equipment Required

1. A radioactive source of known nuclide and activity, which is found within typical contamination to be monitored. The PM12 is designed to monitor radioactivity on the surface of the body to levels less than 400 Bq (11 nCi) of ^{60}Co , as well as quantify

significantly larger activities, up to in excess of 5 MBq (130 μ Ci). Since the PM12 has a very linear response to activity, any source of activity between 185 kBq (5 μ Ci) to 400 kBq (11 μ Ci) range may be used. Long count times will be required for small sources to maintain statistical accuracy against adverse background influences.

2. A source holder, to securely retain the source for positioning within the portal.
3. A generic USB printer, (e.g. Epson LX300)

Preparation for Calibration

First the user must enter the [Calibration Menu \(page 5-35\)](#). Select [HV Scan \(page 5-41\)](#) and check the detector HV's are set correctly for the Calibrating isotope. If these are not known, they must be determined as described in [Detector HV Selection \(page 9-3\)](#) before proceeding with the calibration. The PM12 is then ready for calibration.

Calibration

Ensure the background is stable and any calibration sources are well away from the PM12 (at least 20 feet).

1. Ensure the portal is empty and the unit is on and ready.
2. Login to the Administration mode, using the Health Physicist role (see [Gaining Access to the Administration Mode \(page 5-3\)](#)).

See [Cal Check \(page 5-35\)](#) for more information.

To check the calibration, the *Cal Check* button is selected. This does not allow the calibration factor to be changed, but a comparison is made between the old and new factor.

To recalibrate the instrument, i.e. adjust the calibration factor for a particular nuclide, the *Calibrate* button is selected.

The calibration process should be repeated for a number of nuclides that would be found in typical contamination. As a minimum, a calibration to both ^{137}Cs and ^{60}Co should be undertaken.

Notes: Ensure that each source is at least 20 feet away from the PM12 during the background measurement.

At the end of the calibration, the user is prompted to PASS or FAIL the calibration. If the result is not within 15% of the

reference values in table below – it may be appropriate to FAIL (or Cancel) the calibration.

	⁶⁰ Co (1.2 MeV)	¹³⁷ Cs 662 keV)	¹³³ Ba (356 keV)	⁵⁷ Co 125 keV)	Co-Win – ⁶⁰ Co
Centroid	17%	8.5%	11.8%	4.6%	7.1%
7.5 cm (3")	21%	11%	15%	6.5%	9.3%
Foot (contact)	41%	21%	26%	15%	16%

See [Specification \(page 3-1\)](#) for more information regarding the various PM12 types.

NOTES: *If the efficiency is very different from the expected value and the background is stable, perform an HV scan (see [Performing the HV Scan \(page 9-4\)](#)) and repeat this procedure.*

The Instrument Configuration Report (See [Reports \(page 5-48\)](#)) will provide a hard copy of the set-up and calibration results.

Calibration for Other Nuclides

See [HV Scan \(page 5-41\)](#) for more information.

Efficiency factors for other nuclides and mixtures of nuclides can be defined in a similar manner to that for ⁶⁰Co described in [Preparation for Calibration \(page 10-2\)](#). Before calculating efficiency factors for new nuclides, it would be advisable to verify those for ⁶⁰Co and / or ¹³⁷Cs, ensuring that the PM12's detectors are functioning correctly.

If low energy nuclides need to be monitored such as ⁵⁷Co, then it may be necessary to undertake an HV scan for that particular nuclide. Follow the procedure described in [Performing the HV Scan \(page 9-4\)](#), specifically for the Figure of Merit method (see [Figure of Merit \(FOM\) method \(page 9-6\)](#)), in order to find the best operating voltage.

Calibration mixes

The PM12 will allow "calibration streams" to be set, which will include a number nuclides and their associated percentage in the mix. The PM12 will take account of the respective efficiency of the nuclide and the percentage, to evaluate the overall efficiency of the PM12 to the mix. Note that even when the PM12 is calibrated to a single nuclide, such as ¹³⁷Cs, this is still treated as a single nuclide stream. Only those nuclides to

which the PM12 has been calibrated, may be included in the mix.

[Calibration Selection \(page 5-40\)](#) shows how to create the mix for a new calibration stream.

It is not essential that the percentage of all the nuclides entered adds up to 100 %. In this situation, the PM12 will assume the unidentified percentage is due to undetectable nuclides, such as ^{55}Fe , and adjust the overall percentage efficiency to the mix appropriately.

Troubleshooting (Calibration)

If Background Values Vary by More Than 30%

CHECK IMMEDIATE AREA AROUND PM12 FOR A LOCAL SOURCE OR DIRECTIONAL BACKGROUND FIELD "SHINE".

The background operating voltage may be adjusted in steps of 25 V for a particular detector in order to increase or decrease the background response to be more consistent with the other detectors.

HOWEVER ANY ADJUSTMENT OF THE VOLTAGE WILL INVALIDATE THE NBR MODE AND ^{60}Co WINDOW, WHICH MUST BE SET USING THE METHOD DESCRIBED IN [Selection of Detector Operating Parameters \(page 9-3\)](#).

If Nuclide Count-Rate Outside Required Value

If only one of the detectors is outside the required value, change the relevant HV setting as described in the previous section.

AGAIN, ANY ADJUSTMENT OF THE VOLTAGE WILL INVALIDATE THE NBR MODE AND ^{60}Co WINDOW, WHICH MUST BE SET USING THE METHOD DESCRIBED IN [Selection of Detector Operating Parameters \(page 9-3\)](#).

Significant deviations from the expected efficiency indicate a faulty detection assembly, and remedial action should be taken.

Chapter 11 Maintenance and Trouble Shooting

Fault Messages

The fault messages produced whilst in the application are directly controlled by the software written by Thermo Fisher Scientific whereas errors reported from the motherboard Bios or the Window's operating system will be supplier dependent.

Power-up Screens

On switching ON the screen will remain blank for several seconds whilst the Bios carries out basic checks on the motherboard. The screen will eventually show scripting which details the progress of these initial tests. Should a fault be found the process will halt with the fault/error detailed. This should be recorded and reported to Thermo Fisher Scientific's service department. The equipment cannot be used until the fault is removed.

It must be noted that a failure of the LCD backlight module will leave the display blank even though "boot-up" is taking place correctly.

In a normal boot-up the Bios' sequence of tests will be followed by loading the operating system from the disk drive, signalled by the Thermo Fisher Scientific log screen. Any failure here will result in a "blue" screen. Again you will need to contact Thermo Fisher Scientific's service department if this does occur.

Finally the application software will be loaded and the PM12 User screen will be displayed.

Self Test Screens

The application is entered with tests to verify the detection components are working correctly. Should a failure occur during these initial checks then the "Out of Service" message will appear on the message bar and one of the following will be displayed on the message bar:

1. Unable to set detector alarms
2. Database Offline
3. Unable to Configure Detector Subsystem
4. Invalid Language Setting

5. Default Calibration has no Alarms
6. Configured Error
7. Failed to Retrieve Sound Data From Database
8. No Default Calibration Selected
9. X-Channel Failure
10. X-Channel Failure Accessing Node {0}, ID {1}

Device Error Messages

If one of these messages occurs, a fault with a peripheral device is indicated. Normal operation of the PM12 can be continued when action has been taken to rectify or circumvent the problem.

PRINTER NOT ACCEPTING DATA - The printer refused to accept data for over ten seconds. This may be due to the printer being disconnected, off-line or turned off. Check the printer and the connection to the PM12 (see [Network Communications \(page 3-6\)](#)).

Operational Self Tests

Whilst the PM12 is in Background Checking mode, certain aspects of the instrument's operation are tested repeatedly. If a fault is detected, the PM12 will display the appropriate message as follows:

1. Amplifier Failure
2. Amplifier Counter Failure
3. Amplifier Counter Overflow
4. Amplifier HV Over Current
5. Amplifier HV Over Voltage
6. Amplifier HV Under Current
7. Amplifier HV Under Voltage
8. Amplifier Dead Time Saturation
9. Amplifier EEPROM failure
10. Front Lamp Control Failure
11. Rear Lamp Control Failure
12. X-Channel Failure
13. X-Channel Failure Node {0}

The fault messages produced whilst in the application will, typically, result in the "OUT of SERVICE" and "Critical Error" messages being displayed. Reference to [OUT OF SERVICE \(page 5-94\)](#) may assist to clear this fault and allow continued operation.

An extreme failure may result in the Window's "blue" screen halting further activity. This will require rebooting the software. However, continued occurrence of this fault would suggest a serious problem that needs reporting to Thermo Fisher Scientific's service department.

Servicing of the Electronic Assemblies

The Assembly **11705184** contains the Power Supply module and isolator, assembly **11705186** contains the HV & Amplifier modules, assemblies **11705182A/B** contain the annunciators, assembly **11705181** contains the Charger PCB, Main Controller boards and voltage distribution card. Mounted on the front corner panel is the Display assembly **11705210**.

NOTE: AS A MATTER OF GENERAL ELECTRICAL SAFETY AND FOR CONTINUED EMC PERFORMANCE, ANY EARTH TAGS, WIRES, CONNECTORS OR COVERS REMOVED FROM ANY PART OF THE PM12 IN THE COURSE OF SERVICING, MUST BE REFITTED. CARE SHOULD BE TAKEN AT ALL TIMES NOT TO SHORT THE BATTERY TERMINALS.

Access to Electronic Chassis

NOTE: THERE ARE NO DANGEROUS VOLTAGES IN THIS COMPARTMENT.

HOWEVER IT IS WISE TO SWITCH THE UNIT OFF AND TRIP THE PM12 ISOLATOR TO 'OFF' BEFORE DISCONNECTING ANY CABLES OR REMOVING CARDS.

!!!REMEMBER THE BATTERIES ARE STILL CONNECTED!!!

To gain access to the Electronics Chassis 11705181 components the Main corner frame must be opened. To do this first remove the inside panel and then remove the 4 screws securing the corner section to the main side frame. Carefully swing the corner open to reveal the chassis.

Removal of the Electronics Chassis from the Corner Frame

NOTE: Before commencing this operation, disconnect the two battery cables (11705227 & 5659B) to the battery controller card found at the bottom of the electronic chassis. See picture below.

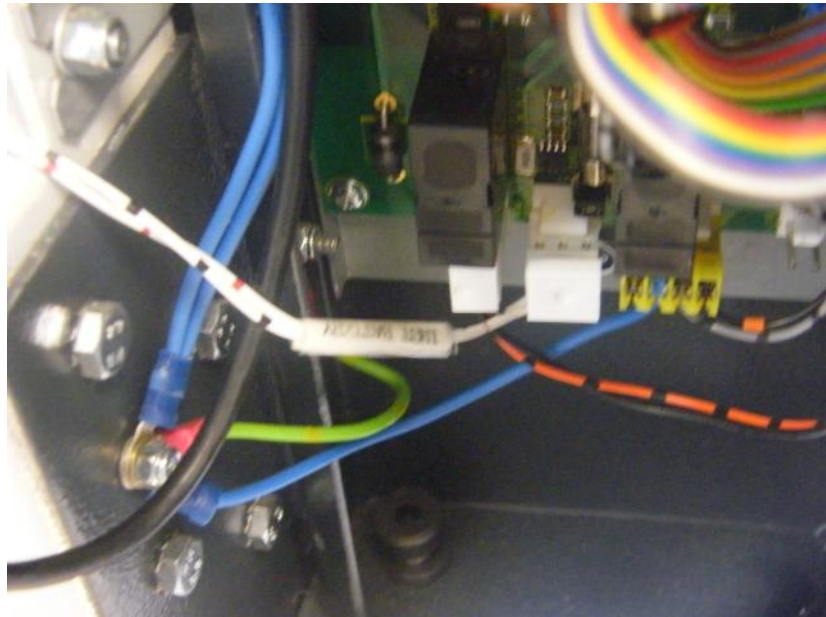

Alternatively, see [Battery - Removal and Replacement \(page 11-6\)](#) for guidance.

When carrying out major Servicing work on the Electronics Chassis 11705181, it may be advantageous to remove it from the PM12. The chassis is quickly and easily removed from the main frame as follows and since the assembly is complete, stand-alone testing is also possible.

The flexible cable conduit will need to be un-hitched from the top of the chassis, down, to allow the chassis plate to swing out from the corner profile.

Disconnect the following cables from the boards:

1. LVDS cable 11705228 and earth
2. Backlight cable 11705229
3. Touch Screen cable 70278KF
4. PSU cable 11705233
5. Keyswitch cable 11705234
6. USB cables on SKB7, 8 of 5691A
7. I2C cable 11705207
8. X-channel; cable 11705220
9. I/O cables 11705208 and 2xx
10. Loud speaker cable 11705242
11. The network cable in SK10 of 5691A is removed

The Electronics Chassis is now freed by removing the three retaining nuts securing the chassis to the panel.

Holding the assembly by the heatsink will allow the assembly to be with-drawn in a clockwise movement and be lifted clear of the Main Corner Frame.

When refitting the Electronics Chassis 11705181 into the Main Corner Frame, ensure:

- All the cards are securely screwed down.
- The ETX assembly and heatsink are correctly fixed.
- The disk drive cable is correctly fitted.
- All three fixing bolts are fitted and tightened.
- All cables are returned to their associated plugs/sockets connecting battery cables 11705227 & 5659B last.
- All earthing points are restored.
- Restore the cable harness to its original wrapped condition.

Removal and Replacement of the Power Supply

IMPORTANT: BEFORE ANY WORK STARTS ENSURE THAT THE MAINS SUPPLY IS DISCONNECTED FROM THE PM12 AND THE PM12 IS POWERED OFF.

The mains power supply for the PM12 is mounted in the top plinth section of the main frame.

Having first disconnected the mains supply and removed the cover from the top plinth locate the PSU assembly. Two bolts retain the assembly, one of which needs the protective lid to be removed for access to.

Remove the connections of cable 11705233 (output) and the earth strap to the CEP to extract the assembly for repair on the bench.

On the PM12C the AC spur connection will need parting before removal of the assembly.

Power Supply Replacement

The Power Supply module contains dangerous high switching voltages and is not user serviceable. It should be returned to Thermo Fisher Scientific's service department for repair or replacement.

Ensure the correct type of replacement power supply is used (See [Recommended Spares List \(page 12-1\)](#)). Replacement of the Power Supply is the reverse of the removal procedure. If the Power Supply is thought to be faulty it should be replaced with an identical unit (See [Recommended Spares List \(page 12-1\)](#)). Replace the connections ensuring all the clamping screws are tight and all GROUND/EARTH connections are made. Ensure the cover is replaced to protect the user from any high voltages.

Adjustment of PSU

There is no PSU adjustment.

Mains Inlet/Filter & Isolator

In the event of either part requiring replacement, it must be replaced with a unit of identical type. When re-connecting the mains wiring, ensure the mains inlet earth connection is made securely to the Central Earth Point (CEP). These requirements are mandatory and necessary for continued EMC performance and user safety.

Battery - Removal and Replacement

CARE SHOULD BE TAKEN AT ALL TIMES NOT TO SHORT THE BATTERY TERMINALS or DAMAGE THE FOOT DETECTOR WHILST THE FOOT TREAD PLATE IS REMOVED.

The battery is a sealed lead/acid jelly type construction and does not require regular maintenance. Batteries should be periodically tested for capacity and will probably need replacing after 3-4 years. If however, it requires replacement, proceed as follows:

1. Switch off the power, switch off the PM12.
2. Remove the two inner panels.
3. Remove the foot tread plate by undoing the 14 fixing screws and lifting one side up to allow withdrawal from the frame.

4. Remove the right-hand reinforcing strut to gain access to the battery compartment lid.
5. Remove the retaining screws on the battery compartment and lift the covering lid off.
6. The battery may be tilted out to reveal the connecting cables.
7. Disconnect the thermistor assembly from the negative BLACK terminal marked '-', taking care not to short it to the '+' terminal.
8. Disconnect the red wire from the positive RED '+' terminal taking care not to short it to the terminal.
9. Remove the battery. Dispose of it safely as required. The battery should be replaced only with one of a similar type or operation of the PM12 may be impaired.

When refitting the battery, make sure the mounting bracket is properly secured. Reconnect the red wire to the RED + terminal first.

Reconnect the thermistor card to the BLACK - terminal last. Failure to do this may impair charging control and may lead to premature battery failure.

The battery contains hazardous substances; please take care to dispose of the old battery in accordance with your local regulations – in Europe Directive 2006/66/EC.

Hard Disk Drive Removal and Replacement

The Disk Drive is situated near the top of the Electronics Chassis.

Switch off the power and remove the electronic chassis as described in [Removal of the Electronics Chassis from the Corner Frame \(page 11-4\)](#).

The disk may be removed with the chassis in situ but care will be needed in refitting the holding screws .

Disconnect the ribbon cable 11705206; remove the four screws and washers securing the drive to its anti-vibration mounts. The disk is now free to be removed from the Electronics chassis.

Replacement of the Hard Disk

Replacement of the disk is the reverse of the removal procedure. Should the disk be thought to be faulty it should be replaced with an identical unit (See [Recommended Spares List \(page 12-1\)](#)) preloaded with all necessary software.

When the instrument is first started with the replacement disk the application will signal "out of service" because of missing

calibration data or has unprogrammed amplifier node addresses. Since node addresses are different for each machine, the hard drives are set up generically and must be completed using this procedure before the instrument can be operated.

This document describes the necessary steps to complete setup of the hard drive. You will need a USB Keyboard to complete this process. Make sure that the PM12 Dongle is installed into one of the USB ports during this process.

Setup Instructions

I. Node Address Settings

1. Power up the PM12 system using the keyswitch. Please note, errors will be displayed on the instrument screen until the steps outlined in this document are completed.

If the windows “found new hardware” box appears, press “cancel” on the screen and the instrument will continue to boot.

When the system fully boots, “Out of Service” will appear on the screen.

2. From the PM12 menu, access the Administration Mode by pressing on the “PM12” icon in the bottom left hand corner of the touch screen. When the “ERROR” box appears, choose “OK”.
3. The windows embedded login screen will appear. Login with the following credentials:
 - User name: administrator
 - Password is: Omr3hT caution “0” = zero, not the letter “O”. **Note: if additional “found new hardware” messages appear, select “cancel”.**
4. From the windows desktop, double tap on the “DeviceConfig” application. From the X-Channel configuration screen, we will enter the amplifier addresses. The amplifier addresses will be on a lable for each of the two system amplifiers visible by removing the detector panels. They are a 4 digit number, enter them exactly as they appear.

Make note of the amplifier addresses:

Amp1____Amp2____Amp3____Amp4____

5. Enter the amplifier addresses into the configuration screen as follows:

- a. Tap on the Device, Amp 1-4 or BattCharger that you want to change
 - b. When Highlighted, tap “Change Address”
 - c. Enter the new address number xxxx into the “New Address” line
 - d. Tap “Change Address”
 - e. Repeat a-d for each amplifier.
 - f. If the BattCharger is not automatically set to 70, set it as this time following the same steps as done for the amplifiers.
 - g. After all amplifiers and BattCharger set, tap “Save to Config file”. Confirm the save tapping “OK”.
Note: depending on the machine options, the barrier and Lamp box may need to be checked/unchecked and the configuration saved as well.
6. After the configuration is saved, Tap “exit” and shut down the system, following \Standard windows shutdown protocol.
 7. Power down the PM12 when it is safe using the keyswitch, and then restart after a few seconds.
 8. The machine should power up normally, but may require setup of alarms and calibration proceed to the next section.

II. Alarm Set, Active Calibration and other parameters

Note: there may be default values that allow the system to boot properly if no errors are noted on boot up. If this is the case, refer to your specific procedures to confirm instrument settings.

1. From the PM12 menu, Access the Admin. “Health Physicist” user mode by pressing on the “PM12” icon in the bottom left hand corner of the touch screen. Select the desired user type (Health Physicist) and tap “OK”.
 - The Password for Health Physicist is “HP”
 - You may enter the password on the screen keyboard, then tap “enter”
2. From the setup screen, tap “setup”, then “alarms”
3. Enter values on the “Normal” and “Cobalt-60” lines.

Battery Controller Board Type 5660A - Removal and Replacement

Switch off the power and remove the electronic chassis as described in [Removal of the Electronics Chassis from the Corner Frame \(page 11-4\)](#).

The charger PCB is situated at the bottom of the Electronics Chassis.

Disconnect any cables, remove the four screws and washers securing the PCB to its mounting spacers. The PCB is now free to be removed from the Electronics chassis.

Replacement of the Charger PCB

Replacement of the charger PCB is the reverse of the removal procedure (PL3 last). Should the Charger PCB be thought to be faulty it should be replaced with an identical unit (See [Recommended Spares List \(page 12-1\)](#)).

The PCB may be removed with the chassis in situ but as difficulty may be experienced in remounting the holding screws this is not advised.

Controller Boards type 5691A & 5694A Removal and Replacement

Switch off the power and remove the electronic chassis as described in [Removal of the Electronics Chassis from the Corner Frame \(page 11-4\)](#).

The 5691A Controller board & the 5694A I/O card are linked together by SK11/PL11. Both cards will need to be removed together to replace any one of them.

Remove all the screws retaining the PCBs to their mounting spacers. The PCBs can now be removed from the Electronics chassis.

Replacement of the Controller boards

Replacement of the Controller PCBs is the reverse of the removal procedure. If the Controller is thought to be faulty, it should be replaced with an identical unit (See [Recommended Spares List \(page 12-1\)](#)).

Remember to transfer the Flash memory from the old card to the new one as this contains all the necessary configuration data

Set the Links on the 5691A as follows:



LK1

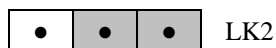

LK2

LK3



LK4



LK5

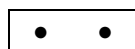

DC-DC Converter 5675A - Removal and Replacement

Switch off the power and power down the PM12. The 5675A may be removed from the top of the Electronic Chassis with/without removal of the latter from the corner frame.

Only two cables need disconnecting, B91918B/A & 11705231.

Replacement of the DC-DC Converter board

Replacement of the 5675A is the reverse of the removal procedure. Should the Controller thought to be faulty it should be replaced with an identical unit (See [Recommended Spares List \(page 12-1\)](#)).

FHT681 cards - Removal and Replacement

WARNING: THE HV & AMPLIFIER PCB'S GENERATE DANGEROUS HIGH DC VOLTAGES. EXERCISE CAUTION WHEN SERVICING, ALWAYS ALLOW THE HV TO DISCHARGE BEFORE COMMENCING WORK.

The FHT681 cards (4 maximum) are mounted in pairs in the top sections of the side frames behind the inner side panels.

They are protected inside a metal shield which can be removed by undoing wing retaining nuts.

A label on the shield identifies how the cards connect with pairs of detectors and the address of the cards.

Basically the right-hand amplifier assembly connects with detectors on that side and the Foot detector. The Head detector, along with the left-hand detectors, connect with the left-hand amplifier assembly

BEFORE ATTEMPTING TO REMOVE ANY FHT681 BOARD, SWITCH THE PM12 OFF AND WAIT 1 MINUTE FOR THE HV TO DISCHARGE BEFORE BEGINNING WORK.

To remove any assembly from the frame, first disconnect the ribbon cables that link the assembly to the control cards, 11705220 and/or 11705221.

Then release the MHV coaxial cables from the HV & amps cards

With the assembly removed carefully pries each pcb from its port after undoing the four securing screws. The remaining interconnecting cable will also need removing.

Replacement of the FHT681HV-Amps

Replacement of any of the boards is the reverse of the removal procedure. Ensure the detector cables are matched to the correct amplifier connector PMT1 or PMT2 as detailed on the enclosure label.

If any Board is thought to be faulty it should be returned to Thermo Fisher Scientific's service department for repair.

Replacement of any amplifier will require recording its serial number on the relevant enclosure label and informing the software of this new address.

NOTE: All cards MUST be linked up using the cables originally supplied

Since removal of any card will have produced an X-Channel error. The user will need to log-out, insert the administrator Dongle, and log on as Administrator. You will need to connect a USB keyboard to carry this out.

NOTE: All cards MUST be linked up using the cables originally supplied

Changing the FHT681 Address

Since removal of any card will have produced an X-Channel error. The user will need to log-out, insert the administrator Dongle, and log on as Administrator (default password being 0mr3hT).

You will need to connect a USB keyboard to carry this out:

4. Select the shortcut to "DevConfig".
5. Select "Load Devices" and highlight the removed card's address.
6. Select "Change Address" to retype the new serial number.
7. Press "OK" to register and "Save" to store as the new address.
8. Exit this routine and log on as Thermo User again.

Setting the FHT681 Current Limits

On a card exchange, it will be necessary to check the Min and Max current levels for each detector are "50" and "200" respectively using the **HV Power** mode facility. They will need

resetting, if they are still set to "0" and "255", using the same facility.

When these values are correctly set the application will be able to report any detector disconnection or light leak.

LCD Display, Touch Screen, Touch Controller & Backlight Inverter - Removal and Replacement

WARNING: The Backlight Inverter generates dangerous high voltages. Exercise caution when servicing, always allow the HV to discharge before commencing work. Do not remove the Inverter from its protective screening enclosure.

Refer to assembly drawing 11705210 for details.

Switch off the power .Ensure the PM12 is OFF.

1. Remove the screws from the rear of the display housing and remove the back-plate.
2. The back-light and Touch-screen controller cards lie beneath removable protection covers on the back of the display.
3. Take care in removing the connecting cables.

Both the Touch Controller module and the Back-light Inverter are propriety items and are not user serviceable. They should be returned to Thermo Fisher Scientific's service department for repair or replacement.

1. To remove the LCD display, disconnect all cables (3).
2. Undo the display retaining screws located round the periphery of the metalwork.
3. Gently pull the front bezel assembly away from the main housing and lay carefully onto a flat surface.
4. Four screws attach the LCD shield to the front bezel.
5. On removal the LCD and shield can be lifted from the bezel and touch screen, itself sitting in a recess of the plastic bezel.
6. The touch screen is not fixed to the bezel. Another four screws hold the aluminium shield to the LCD, via spacers.

Replacement of the LCD Display, Touch Screen, Touch Controller and Backlight Inverter

Replacement of the LCD Display, Touch Screen, Touch Controller and Back-light Inverter is the reverse of the removal procedure. Should any item be thought faulty they should be replaced with an identical unit (See [Recommended Spares List \(page 12-1\)](#)).

It is necessary to take special care in handling the Touch Screen and LCD, to keep all faces free of dirt and finger marks!

Annunciator Panels LED's/Switch - Removal & Replacement

The two annunciator panels **11705182A/B** house display cards 5672A & 5700A and a switch assembly.

The related corner members of the PM12 will need opening to gain access to the cards and the separate push-switch.

The switch may be removed at this point.

However to remove either pcb it will be necessary to undo the annunciator housing from the corner frame to gain enough access to the mounting screws.

Disconnection and removal of these items are obvious. The LED's are propriety items and therefore are not user serviceable. They should be replaced with identical parts as detailed in [Recommended Spares List \(page 12-1\)](#).

Sensor Assembly 11705235A/B/C/D & Interconnection cards 5697A - Removal & Replacement

The sensor assemblies are connected to the control cards via an interconnect card 5697A. This is located at the top of each corner frame. These in turn are ribboned to the I/O connectors of the 5694A (front & rear cables).

On earlier PM12s, the front sensor blocks were linked to one interconnect card on the LH side whilst the rear two were linked to the RH interconnect card.

Additional ribbon cables (2) now interconnect the front & rear assembly pairs in a LH to RH fashion.

The related corner members of the PM12 will need opening to gain access to these cards and sensor assemblies.

The Sensor Assembly can be removed after un-wiring the leads from its interconnect board. Two bolts retain the sensor assembly in place on the corner member (horizontal entry).

Similarly the interconnect card can be removed by unwiring the sensor leads and unplugging the ribbon cable(s) Either remove the sub-chassis or the 4 retaining screws to withdraw the card.

The sensors are propriety items and therefore are not user serviceable. They should be replaced with identical parts as detailed in [Recommended Spares List \(page 12-1\)](#).

Start Switch, Keyswitch and Loudspeaker - Removal & Replacement

These items are unlikely to fail or need regular servicing. However, in the event of failure, their removal and replacement is obvious. See [Recommended Spares List \(page 12-1\)](#) for component details.

WARNING: Unplug the mains lead and disconnect the battery to avoid the PM12 switching on inadvertently as the start switch connector is unplugged.

Detector Removal and Replacement

NOTE: The detectors are light sensitive and, because of this, are contained in a light-tight enclosure. Care must be exercised at all times not to damage the enclosure as subsequent damage to the photomultiplier tube may result due to light leaks.

Removal

CAUTION: TO AVOID LEAD CONTAMINATION, THE LEAD PIECES SHOULD BE HANDLED WITH GLOVES. WASH HANDS AFTER HANDLING. REFER TO THE MATERIAL SAFETY DATA SHEET THAT ACCOMPANIES THE LEAD.

LEAD IS AN EXTREMELY DENSE MATERIAL. SOME OF THE LARGE PIECES OF SHIELDING WEIGH UP TO 35 KGS. USE CORRECT HANDLING PROCEDURES TO AVOID PERSONAL INJURY.

Disconnect the mains supply. Ensure the PM12 is switched OFF

SIDE DETECTORS

1. Remove the inner panel(s) to reveal the side (6) detectors.
2. Undo the retaining bolts to swing out the relevant corner frame(s).
3. Undo the connecting coaxial cable.
4. Remove the holding strap.
5. Carefully withdraw the detector.

TOP DETECTOR

1. Remove the Lid panel to reveal the Head detector.
2. Remove the two lead panels sitting on the detector.
3. Remove the plastic liner.
4. Undo the connecting coaxial cable.
5. Carefully withdraw the detector.

BOTTOM DETECTOR

1. Remove the foot plate.
2. Remove the two ramp braces.
3. Disconnect the Coaxial cable.
4. Carefully withdraw the detector.

TAKE CARE THAT THE DETECTOR DOES NOT FALL!!

Detector Replacement Replacement of the Detectors follows the removal procedure in reverse. Again care must be exercised not to break the light-tight seals.

Once the detectors are in place, refit all spacers, straps and panels .

Setting up Replacement Detectors for Use Replacement detectors or detectors with replacement PMT's will need to be set for optimum performance with the Isotopes of interest. Before determining HV's, the Single Channel Analyser Thresholds must be reset to their default settings or erroneous results will be obtained (see [Thresholds \(page 5-45\)](#)). Once this is done, select the detector operating point using the HV scan procedure detailed in [Selection of Detector Operating Parameters \(page 9-3\)](#).

PM12C GPIO (5707A)

Disconnect the mains supply and switch the PM12 OFF.

The interface unit is housed in assembly 11705312 found in the roof compartment of the portal. The card can be removed from its chassis by removing the cover and unclipping the cables on PL1,4,5,6,8,9 and PL13.

GPIO Replacement The replacement follows the removal in reverse. Ensure the connectors are correctly mated. Replace the lid.

PM12C Barrier Arm and Motor

NOTE: Whilst the motor actuator has a protective clutch to limit the impact force on any obstacle it is prudent to be aware of its "field of play".

Again, work on the unit with the PM12 OFF.

The barrier arm can be replaced by undoing the three retaining bolts that secure it to the motor assembly.

The motor is accessed by removing the four corner panel retaining bolts revealed by unlocking the relevant detector cover. The barrier arm will need removing, as will the motor flange (visible from the outside of the corner panel) by removing the central fixing screw.

Removal of the motor is possible after undoing the two nyloc nuts (rear of motor) holding the drive to the holding plate that is

secured to the panel work. The attached cable can be unplugged locally to allow complete removal of the motor.

Barrier Replacement

Replacement of the Barrier motor and/arm follows the removal procedure in reverse.

PM12C Powered Doors

There are no user serviceable items on this unit. Please contact Thermo Fisher Scientific service department for support.

Troubleshooting (Operational)

This Section covers a number of possible operational problems, their likely causes and possible remedial action.

WARNING: EXERCISE EXTREME CAUTION WHEN SERVICING.

There are dangerous mains voltages around the power supply module and very dangerous high voltages on the HV and amplifier boards. High voltage also exists on the LCD backlight and in the inverter enclosure. The 12 v battery stores considerable energy, so care should be taken not to short the terminals. Please read the cautionary notes in [Servicing of the Electronic Assemblies \(page 11-3\)](#).

Normal Start-up (Boot-up) Operation

In general a successful start, or "boot up" when the PM12 key-switch is turned is indicated by:

- a series of "System Self Test" display messages
- a series of lamp tests , each accompanied by a "beep" tone
- a series of internal (invisible) self tests
- a single chime "ding-dong" on satisfactory completion

Unit "dead" (will not boot up) & charging LED is OFF

If the display remains blank and unlit, no lamps are lit and no sound is heard (assuming the volume has not been turned off) it would indicate that the PM12 is "dead".

LED OFF - indicates the AC mains supply is OFF and instrument cannot run off the battery.

1. Check the fuse on the 5660A charger PCB, FS1.
2. If the fuse is intact, the battery is probably discharged. Check the voltage at PL4 on the charger PCB. If it is

below 11.2 volts, the battery is discharged and the charging supply must be restored before further operation is possible.

Restoring the AC mains/charging supply - should light the LED and allow the system to run while charging the battery.

1. Check the AC mains power cord is connected.
2. Check the fuse in the mains adapter (if fitted).
3. Check the power supply is receiving the mains supply.
4. Check the power supply output on 5660/PL4 (temporarily remove from pcb to check) - no output indicates the internal fuse has blown and the power supply should be replaced (see [Removal and Replacement of the Power Supply \(page 11-5\)](#)).
5. Check the output on PL3 of the 5660A charger PCB - it should be greater than +12.5 volts.

Unit "dead" (will not boot up) & charging LED is ON

LED ON - indicates the AC mains supply is ON and should be powering the instrument while charging the battery.

1. Retry switching the unit ON.
2. Check the fuse on the 5660A charger PCB, FS1.
3. Check the battery voltage is greater than 12.5 volts.
4. Check there is battery volts on OUTPUT connector PL6. If no output is observed on PL6, a fault on the Charger PCB is indicated and it should be replaced as detailed in [Replacement of the Charger PCB \(page 11-10\)](#).
5. Check the power connections from the 5660A Charger PCB to the 5691/94A Controller boards.
6. Check the regulated +12 V, -12 V & +5 V outputs from the DC-DC converter module 5675A. The DC-DC module is not user serviceable and if faulty the Converter board should be replaced as described in [Controller Boards type 5691A & 5694A Removal and Replacement \(page 11-10\)](#).
7. Switch unit OFF and replace the Controller board as described in [Controller Boards type 5691A & 5694A Removal and Replacement \(page 11-10\)](#).
8. If the PM12 is still dead after changing the Controller board, contact Thermo Fisher Service department for further help.

Starts-up but Display is "Blank" & Fails Self Tests (no chimes)

If the PM12 starts but fails to chime ("ding-dong") within 60 seconds of being switched ON, then it has not successfully completed the power-on Self Tests and a fault is indicated. Observe the LCD display, if a fault message is displayed refer to subsequent subsections. If, however, the display is blank or the message is unintelligible, it is likely the Controller board has a serious fault and the microprocessor has I/O problems or has crashed. Replace the Controller board as described in [Controller Boards type 5691A & 5694A Removal and Replacement \(page 11-10\)](#).

Will not run & displays "Out Of Service – Low Background Counts"

The blue FAULT lamp is lit (see [Fault Messages \(page 11-1\)](#)) for an explanation of the fault messages). The Self Tests have detected the background count from the detector channel is below the Low Background Alarm value set in [Params 1 \(page 5-13\)](#). Proceed as follows:

1. Enter a valid password and Setup|[Params 1 \(page 5-13\)](#). Check that the Low Background Alarm is not set to an unreasonably high value for the prevailing background condition.
2. Select Calibration|[HV Scan \(page 5-41\)](#) and check the HV settings for each channel are correct.
3. Check the cable connections between the Controller board and the HV & Amplifier pcbs.
4. Having performed checks 1 to 3 above, select Diagnostics|[Detector Bar \(page 5-28\)](#), perform a 10 second count and check the faulty channel/s and note the counts.

Zero counts in a channel usually implies a complete failure in either the detector assembly or HV/Amplifier PCB. A few counts suggests either reduced detector efficiency or threshold problems in the HV/Amplifier.

1. Swap the faulty detector MHV connection from the relevant HV/Amplifier to that of a working channel. Perform a further 10 second count and note the counts in each channel.
2. If the fault moves with the detector into a previously working channel, the fault is in the detector assembly and should be replaced as defined in [FHT681 cards - Removal and Replacement \(page 11-11\)](#).
3. If the fault remains with the original HV/Amplifier channel, the fault is in the HV & Amplifier PCB and this should be replaced as defined in [FHT681 cards - Removal and Replacement \(page 11-11\)](#).

**Will Not Run & Displays
"Out Of Service – High
Background Conditions"**

This condition occurs when the Background activity prevents the PM12 from discriminating the pre-set alarm level with the required confidence within the Maximum Monitoring Time allowed. Enter a valid password and proceed as follows:

1. Select Setup|Params 2 (page 5-14) and check the Maximum Monitoring Time is set to a reasonable value. Adjust it upward if necessary.
2. Select Setup|Alarms (page 5-18) and check the Normal Alarm level is set to a reasonable value. Adjust it upward if necessary.
3. Select Setup|Params 2 (page 5-14) and check the Probability of False Alarm is set to a reasonable value. Reduce it if necessary.
4. Select Setup|Params 2 (page 5-14) and check the Probability of Detection is set to a reasonable value. Reduce it if necessary.
5. Select Calibration|HV Scan (page 5-41) and check the High Voltage settings of ALL eight detector channels are correct.
6. Select Setup|Params 2 (page 5-14) and set a 10 second Minimum Monitoring Time. Check the counts in all four detector channels are reasonable for the expected ambient background level using Diagnostics|Detectors (page 3-3).
7. If a single channel shows a background count significantly greater than the other detectors, a noisy channel or a light leak is likely. Proceed as follows:
 - Swap the faulty detector MHV connection from the relevant HV/Amplifier to that of a working channel. Perform a further 10 second count and note the counts in each channel. (*N.B. Bear in mind the different operating voltages*).
 - If the fault moves with the detector into a previously working channel, the fault is in the detector assembly and should be replaced as defined in [Removal \(page 11-16\)](#).
8. If the fault remains with the original HV/Amplifier channel, the fault is in the HV and Amplifier PCB and this should be replaced as defined in [FHT681 cards - Removal and Replacement \(page 11-11\)](#).
9. If all channels show a background count significantly greater than that expected, the PM12 is experiencing an elevated background. Proceed as follows:

- Check the area immediately around the PM12 for sources of any possible contamination.
- Measure the ambient background level with a suitable survey monitor. If the background is high, it must be reduced or the PM12 moved for normal monitoring operation to resume.

IF THIS CONDITION PERSISTS and the background and measurement limits seem to be reasonable, 'frisk' inside the monitor cubicle for a possible build-up of contamination.

Fails Lamp or LED Tests

A power-on Self Test lights each lamp & LED in turn. If any lamp or LED fails to light in sequence (except the charging LED), proceed as follows - using Diagnostics|[Sensors \(page 5-33\)](#) to re-test lamps as required:

1. Check the connections to the lamp assemblies and to the Controller board.
2. Any device failure will need a replacement board.
3. If there are two lamp assemblies and neither are functioning then a fault on the Controller board is indicated and it should be replaced as described in [Controller Boards type 5691A & 5694A Removal and Replacement \(page 11-10\)](#).

Fails Loudspeaker Test

A power-on self Test produces a single chime "ding-dong" upon satisfactory completion. If no sound is heard, proceed as follows:

1. Enter a valid password and select System|[Setup \(page 5-66\)](#), and increase the volume (as described in [Setup \(page 5-66\)](#)). The speaker should produce a series of "beeps" which gradually get louder or quieter when the volume control is dragged.
2. If no sound is heard, check the speaker connection to the Controller board.
3. Since the speaker is unlikely to have failed, a fault on the Controller board is indicated and it should be replaced as described in [Controller Boards type 5691A & 5694A Removal and Replacement \(page 11-10\)](#).

Fails the LCD Display Test

A power-on self Test switches on the back-light and produces series of "Self Test Messages and "beeps". If the display fails to show any message, or is totally "blacked out" proceed as follows:

1. Check the multi-cable connections from the display to PL5 & PL9 on the Controller board 5691A.
2. If check 1 above has not revealed the problem, a fault in the LCD module or Controller board 5691A is indicated.
3. Temporarily connect a spare LCD module to the Controller board PL5 & PL9 (the back-light is required).

If the message becomes visible, the fault is in the LCD display module. This is not user serviceable and should be replaced (with the back-light) as described in [LCD Display, Touch Screen, Touch Controller & Backlight Inverter - Removal and Replacement \(page 11-13\)](#).

If no message appears, the fault is in the Controller board, which should be replaced as described in [Controller Boards type 5691A & 5694A Removal and Replacement \(page 11-10\)](#).

Display Backlight Failure

A power-on self Test switches on the back-light and produces a series of "Self Test Messages" and "beeps". If the back-light fails to light, proceed as follows:

1. Check the cabling from the back-light inverter enclosure to PL9 on the Controller board.

Check that 5 volts appears across the pins of PL9 when the back-light should be on. If 5 volts is apparent then a fault in the LCD or back-light inverter is indicated. These items are not user serviceable and should be replaced as described in [LCD Display, Touch Screen, Touch Controller & Backlight Inverter - Removal and Replacement \(page 11-13\)](#). If the voltage is absent across the pins of PL9, a fault on the Controller board is indicated and it should be replaced as described in [Controller Boards type 5691A & 5694A Removal and Replacement \(page 11-10\)](#).

Will Not Accept Valid Passwords

If the PM12 starts and runs but will not accept a valid password, a fault is indicated either in the LCD Touch-pad or the Controller board. Proceed to [LCD Keypad Inoperative or Not Aligned \(page 11-24\)](#).

LCD Keypad Inoperative or Not Aligned

If the PM12 starts and runs but will not respond to password entry or returns incorrect characters on the LCD display, a fault is likely in the Controller board or possibly the keypad.

Proceed as follows:

1. Check the cable connections between the Touch screen keypad and the Controller board. If uncertain try a replacement cable to isolate fault.
2. Similarly check the touch control board by replacement.
3. If unsuccessful, temporarily plug a spare LCD assembly into the control board. If this solves the problem the original Touch-pad is faulty and should be replaced as described in [LCD Display, Touch Screen, Touch Controller & Backlight Inverter - Removal and Replacement \(page 11-13\)](#).
4. If the problem still persists the fault is likely to be in the Controller board 5691A which should be replaced as described in [Replacement of the Controller board \(page 11-10\)](#).

Will not Enter Background Mode Or Locked in Background Mode

If, after power-up, or after exiting from the main menu, the PM12 displays "Cannot Measure Background - Please Exit the Portal", a fault with the Infra Red links is likely. Proceed as follows:

1. Check that the Links are working correctly by selecting "Diagnostics/Sensor". The switch and links can be tested for correct operation.
2. Check the continuity of the cable connecting the Sensor(s) to the Controller board 5694A via the Interconnect cards.

Replace the Controller board as described in [Controller Boards type 5691A & 5694A Removal and Replacement \(page 11-10\)](#) if the switches are working correctly.

Locked in Measurement Mode

If the PM12 becomes stuck in a monitoring cycle with the display showing "Count Time Remaining xx seconds" it is likely that microprocessor has crashed. Power down and check again. Continual crashing may indicate that the Controller board needs replacing as described in [Controller Boards type 5691A & 5694A Removal and Replacement \(page 11-10\)](#) possible that the hard disk may have suffered some damage in this area of the program. If the problem persists even after changing the Controller board a new disk should be considered.

USB Output Data is Corrupted

If USB data output from the PM12 to a serial printer, or external computer, contains spurious characters, or is corrupted in any way, check the following possible causes:

1. If no output whatsoever is received, check the data cable connections (see [Displays \(page 3-4\)](#)).
2. If a USB printer is involved, perform a printer self-test, to determine whether the printer itself is at fault.

The following section applies to PM12C only.

**Barriers will not OPEN/
CLOSE
Unreliable Door Operations**

If the entry Barrier fails to Close UP or DOWN, then select the Diagnostic/[Barriers \(page 4-6\)](#) function to exercise the arm. Should this be successful, then check that the front barrier has been Enabled and Closed for one of the three options.

If un-successful, then it will be necessary to verify that power is reaching the motor by examining the voltages on the motor connector when it is asked to close/open (see [Params 3 \(page 5-17\)](#)). If power exists, the motor assembly needs examining to decide whether the motor itself is at fault or the integral microswitches are damaged/ misaligned.









If no problem is found with the motor assembly and its cabling, then suspect the GPIO card. Replacing the 5707A should resolve the fault.

If the Powered Doors malfunction, then use Diagnostic/[Barriers \(page 4-6\)](#) function to exercise the doors. Should this be successful, then check that the rear doors have been enabled.

If unsuccessful, then it will be necessary to exercise the doors via the integral controller found in the rear left hand corner section of the main PM12 frame. See Appendix A Automatic Folding Door System, section Functions of electronic BDE-E9.2 for key functions panel (reproduced below):

1st level (operating modes)

Key functions:

-  One-way operation
-  Winter mode
-  Automatic mode
-  Continuously open
-  Locked
-  Programming
-  Programming increment down
-  Programming increment up

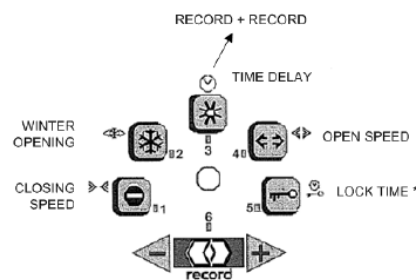

In the normal state, one LED should be lit.

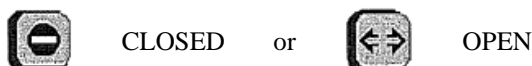

If this is not the case and a LED is flashing, then please refer to Appendix A Automatic Folding Door System, section Status and Fault Signals to identify the fault mode. Thermo Fisher Scientific Service department will need to be contacted for assistance.

If the LED correctly registers the status of the door, e.g. OPEN, then pressing the Close button will close the door and illuminate the closed LED. If this is correctly happening, then suspect a problem with the GPIO (5707A) card and its interconnection cables.

IT IS IMPORTANT THAT THE USER LEAVES THE DOOR IN A CLOSED POSITION AFTER USING THIS CONTROL PANEL OR OPERATION FROM THE PM12 APPLICATION WILL BE INHIBITED. SIMILARLY, IF IN DIAGNOSTICS AND THE DOOR IS OPENED, OPERATION FROM THE REKORD CONTROL PANEL IS RESTRICTED.

Chapter 12 Spares List

Recommended Spares List

The following spares are recommended on the basis that first-line service is best performed by changing modules.

	ETX CONTROLLER BOARD	5691A
	I/O EXPANSION BOARD	5694A
	PM12C CPIO CONTROLLER CARD	5707A
	ETX PROCESSOR	702695PE
	SECURITY DONGLE	A92169/C
	BATTERY CONTROLLER BOARD	5660A
	HV & AMPLIFIER BOARD (FHT681)	425430223
	TOUCH SCREEN	702633ND
	TOUCH-SCREEN CONTROLLER	702632ND
	BACK-LIGHT INVERTER	702549ND
	PWR MODULE	702473KJ
	PUSH BUTTON	11705187
	SENSOR INTERCONNECT BOARD	5697A
	PHOTOELECTRIC TRANSMITTER	702742ND
	PHOTOELECTRIC RECEIVER	702743ND
	DYNODE CHAIN	A3-54040
<i>PM12C only</i>	PM12C POWERED DOOR	11705326
<i>PM12C only</i>	BARRIER ARM MOTOR	702847JB
<i>PM12C only</i>	BARRIER ARM	11705321
<i>PM12C only</i>	GPIO CARD	5707A

Spares List

	ETX CONTROLLER BOARD	5691A
	I/O EXPANSION BOARD	5694A
	DC-DC CONVERTER	5675A
	ETX Processor	702695PE
	Replacement HDD + OPERATING SYSTEM	AE0232A
	5-WAY LED CLUSTER	5672A
	MIMIC DISPLAY	5700
	BATTERY CONTROLLER BOARD	5660A
	BATTERY TEMPERATURE SENSOR	5659B
	SENSOR INTERCONNECT BOARD	5697A
	SENSOR F-LH ASSEMBLY	11705235/A

	SENSOR F-RH ASSEMBLY	11705235/B
	SENSOR R-LH ASSEMBLY	11705235/C
	SENSOR R-RH ASSEMBLY	11705235/D
	SEALED BATTERY	503073KJ
	HV & AMPLIFIER BOARD (FHT681)	425430223
	SCINTILLATION DETECTOR	5678A
	LOUDSPEAKER	11705242
	PWR MODULE AC/DC	702473KJ
	12.1" TFT LCD	702548ND
	BACKLIGHT INVERTER	702549ND
	IC/MEM SDRAM 256MB	702627PD
	COMPACT FLASH	702275KM
	TOUCH-SCREEN CONTROLLER	702632ND
	TOUCH SCREEN	702633ND
	PUSH BUTTON	11705187
	DYNODE CHAIN	A3-54040
	KEYSWITCH	702663KG
<i>PM12C only</i>	PM12C POWERED DOOR	11705326
<i>PM12C only</i>	BARRIER ARM MOTOR	702847JB
<i>PM12C only</i>	BARRIER ARM	11705321
<i>PM12C only</i>	GPIO CARD	5707A

Drawings List (by Assembly)

	PM12 FAMILY TREE	11705191
	<i>(See attached Diagram at back of document)</i>	
	DYNODE CHAIN	A3/54040
42543-0223	HV & AMPLIFIER BOARD	42543/0223
5659B	TEMPERATURE SENSOR BRD	C91794/B
5660A	BATTERY CONTROLLER BRD	C91799/A
5672A	5-WAY LED CLUSTER	D91956/A
5675A	DC-DC CONVERTER BOARD	C91965/A
5691A	ETX CONTROLLER BOARD	E92148/A
5694A	I/O EXPANSION BOARD	E92219/A
5697A	SENSOR INTERCONNECT BOARD	C92234/A
5700A	MIMIC DISPLAY	D92266/A
5707A	PM12C GPIO CARD	E92341
	PM12 INTERCONNECTION DIAGRAM	11705190
	<i>(See attached Diagram at back of document)</i>	
	PM12 OUTLINE DRAWING	11705270

(See attached Diagram at back of document)

PM12C ASSEMBLY 11705301/350
DRAWING

PM12C INTERCONNECTION 11705325
DRAWING

Accessories List

CALIBRATION JIG	AE0215A
SECURITY DONGLE	A92169/A
CHECK SOURCES	details on request
Dot matrix printer	AE0210A
Barcode reader	Details on request

Chapter 13 Glossary of Terms

μCi	micro-curie
A	Attenuation Factor or amps
B_{eff}	Effective Background while Monitoring
Bq	Becquerel
B_{sum}	Total Average Background Count Rate
C	Counter(s)
C_{Act}	Contamination Alarm Level
CCM	Cobalt Coincidence Monitoring
C_{cps}	Contamination Alarm Count-rate
C_{effect}	Effective Alarm Count rate
Ci	Curie
CPM	Counts per minute
D	Door(s)
DL	Detection limit
dpm	Disintegrations per minute
E	Efficiency Correction Factor
Egress	Act of Exiting
F	Probability of False Alarm
FOM	Figure of Merit
Health Physicist	Person, Persons or Team responsible for setting up day-to-day running and maintenance of the PM12
HP	<i>Health Physicist</i>
HV	High Voltage
Ingress	Act of Entering Keyboard Emulating Id Provider
kBq	kiloBecquerel
Keyboard Emulating Id Provider	Another term for USB Barcode Reader
L	Lead
LAM	Large Articles Monitor
LCD	Liquid Crystal Display

LED	Light Emitting Diode
LVD	Low Voltage Directive
MAct	Minimum Detectable Activity
mCi	Milli Curie
MDA	Minimum Detectable Activity
NBR	Natural Background Reduction
NE110 equivalent	Term referring to a specification of plastic
nCi	nanocurie
NORM	Naturally Occurring Radioactive Material
P	Probability of Detection
PCB	Printed Circuit Board
pCi	picocurie
PM	Personnel Monitor or Portal Monitor
PoFA	Probability of False Alarm
Quickscan	Method used to identify, within the monitoring time (see Tmon), whether the article is either “clearly” contaminated or clear, referred to as “real-dirty” or “real-clean”
RAct	Activity of Contamination
RCC	Residual Contamination Count
SAM	Small Article Monitor
Technician	Personnel who normally repair and maintain the instrument in working condition
tB	Background Update Time
Tcal	Calculated Monitoring Time
ThermoFisher	Personnel who are general users of the system and normally carry out routine diagnostic and test functions
Tmax	Maximum Monitoring Time
Tmin	Minimum Monitoring Time
Tmon	Actual Monitoring Time
User	Anyone associated with or operating the instrument.
V	voltage

Index

A

A 6-5
 Actions 5-65
 Adjustment of PSU 11-6
 Administrator Mode 5-1
 ALARM Acknowledge 5-91
 Alarm Check 5-32
 Alarm Display 5-90
 ALARM Result 5-89
 AlarmCheck Report 5-49
 Alarms 5-18
 Alpha-numerical Functions 5-2
 Archives 5-65
 Attenuation 5-46

B

Background Change during
 Measurement 5-86
 Background Report 5-50
 Barriers 5-34
 Battery 5-20, 5-34
 B_{eff} 6-3
 B_{sum} 6-3
 Button Types 5-3

C

C_{Act} 6-4
 Cal Check 5-35
 Calibration Procedure 10-1
 Calibration Report 5-53
 Calibration Selection 5-40
 Camera 5-80
 Cameras 5-28
 C_{cps} 6-4
 C_{effect} 6-4
 Changes to the Normal
 Background Monitoring
 5-75
 Changing the FHT681 Address
 11-11
 CLEAR Result 5-88
 Configuration Report 5-54
 Counts 5-30
 Critical Error 5-95

D

Data Retention 5-67
 Date Functions 5-2
 Description 2-1
 Detector Bar 5-28
 Detector Indicator 5-71
 Determining the operating
 voltage for mid-high energy
 nuclides 9-5
 Direction of Entry 5-79
 DL 6-5

E

E 6-5
 Efficiencies 5-35
 Entering through the Front
 Barrier 5-77
 EPD Id Reader 5-23
 Establishing a new Background
 5-73
 Events Report 5-57
 Exiting the Administration Mode
 5-7

F

F 6-4
 Figure of Merit (FOM) method
 9-6
 File Location Functions 5-3
 Five Light System 5-71

G

Gaining Access to the
 Administration Mode 5-3

H

Hv Power 5-45
 HV Scan 5-41
 HV Scan Report 5-59

I

IDS Camera 5-23
 Information 5-29

Installation of the Foot Detector (#8) 4-5
 Installation of the Head Detectors (#1) and its Lead Shielding 4-5
 Installation of the Side Detectors (#2 and #3 top, #4 and #5 middle, #6 and #7 bottom) 4-5
 Instrument Contaminated 5-93
 Introduction 1-1

K

Keyboard Emulating Id Provider 5-24

M

M_{Act} 6-5
 Maintenance and Trouble Shooting 11-1
 Measurement Results Report 5-62
 Menu Roles 5-6
 Messages 5-21
 Moving through the Menus 5-5

N

NBR method 9-5
 Normal Background Monitoring 5-74
 Notes regarding Changing Background 5-76
 Notes regarding High Background 5-96
 Notes regarding Low Background 5-97
 Notes regarding Normal Background Monitoring 5-75
 Notes regarding Regular Expressions for Barcode 5-25
 Notes regarding Residual Contamination Check 5-92
 Notes regarding Volume Levels 5-66
 Number Functions 5-1

O

Operating Instructions 5-1
 Optical Sensors 4-7
 Options 1 5-8
 Options 2 5-10
 Options 3 5-12
 Out of Calibration 5-73

P

P 6-4
 Params 1 5-13
 Params 2 5-14
 Params 3 5-17
 Passwords 5-67
 Performing the HV Scan 9-4
 Plug-ins 5-21
 PM12 ViewPoint MultiServer 5-25
 Power Supply Replacement 11-6
 Pre-defined Functions 5-2

R

R_{Act} 6-5
 Replacement of the Charger PCB 11-8
 Replacement of the Controller boards 11-9
 Replacement of the DC-DC Converter board 11-9
 Replacement of the FHT681HV-Amps 11-10
 Replacement of the Hard Disk 11-7
 Replacement of the LCD Display, Touch Screen, Touch Controller and Backlight Inverter 11-12
 Reports 5-48
 Residual Contamination Check 5-92
 Restart Required 5-89
 Routine Checks 8-1

S

Sensors 5-33
 Serial Barcode Reader 5-27
 Setting the FHT681 Current Limits 11-11
 Setting Up Procedure 9-1
 Setup 5-66
 Spares List 12-1
 Specification 3-1
 Stand and Count Mode 5-81
 Stand and Turn Mode 5-84
 Start Up Checks 5-72

T

t_B 6-3
 T_{cal} 6-3
 Technical Description - Circuitry 7-1
 Technical Description - Physics 6-1
 Temporary Error 5-96

Terminal Error 5-95
Three Step Mode 5-83
Thresholds 5-45
 T_{\max} 6-4
 T_{\min} 6-3
 T_{mon} 6-3
To configure an Interface 5-22
To unpack the PM12 4-2
To unpack the PM12C 4-3
Two Step Mode 5-82

U

Unpacking and Installation 4-1
User ID 5-78
User Screen 5-69
Using the Touchscreen Functions
5-1

V

Variance Report 5-64
Variance Test 5-30
Version 5-66
Violations during Entry 5-78
Violations during Monitoring
5-85
Voice Prompts 5-72

W

Walk Through Mode 5-81

ILLUSTRATION SHOWING ONLY ONE SIDEFRAME.
QUANTITIES ON BALLONS ARE CORRECT FOR
COMPLETE ASSEMBLY

TO AID REMOVAL OF LOWER
DETECTOR LEAD USE
2 OFF M6x20 SCREWS

ITEM 20:-
ADD DOUBLE SIDED TAPE ITEM 27 TO THE BACK OF THE
LEAD SPACER IN 4 CORNERS ONLY.
ENSURE HOLES ALIGN WITH FIXING HOLES ON SIDEFRAME

NOTE:-
1). ALWAYS ENSURE THE USE OF GLOVES WHEN HANDLING LEAD.
2). FOLLOW A CORRECT AND SAFE LIFTING PROCEEDURE WHEN
LIFTING LEAD SHIELDS INTO POSITION.
3). FOR REMOVAL OF THE TWO INNER COVERS, TREAD PLATE, TOP LID
AND 4 SCREWS ON EACH CORNER SECTION TO ALLOW ACCESS FOR
FITTING THE LEAD SHIELDS. PLEASE REFER TO DRG. 11705121, MAIN
FRAME ASSEMBLY.

CONFIDENTIALITY NOTICE: THIS DOCUMENT (INCLUDING ALL INFORMATION CONTAINED THEREIN) IS
OWNED BY ThermoFisher Scientific and MUST BE KEPT IN CONFIDENCE AND USED SOLELY FOR THE
OWNER'S SPECIFIED PURPOSES. THIS DOCUMENT MUST NOT BE COPIED OR REPRODUCED, NOR
DIVULGED, IN WHOLE OR PART, WITHOUT THE OWNER'S PRIOR WRITTEN CONSENT.

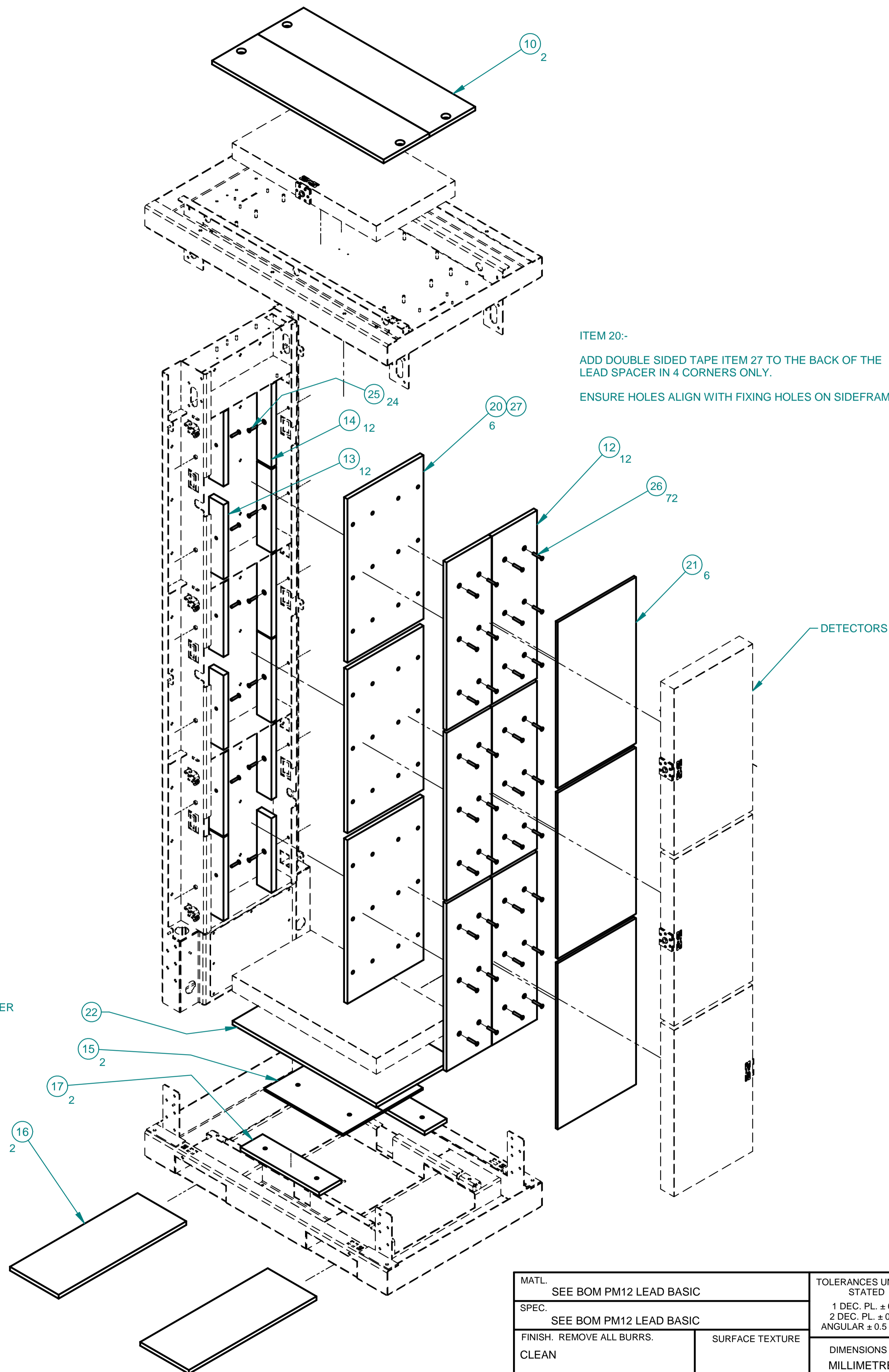

ISO THREADS CLASS 6g/6H

MATL.	SEE BOM PM12 LEAD BASIC	TOLERANCES UNLESS STATED	DRAWN	GEL	ISS.	DATE	DOI/MOD.						
SPEC.	SEE BOM PM12 LEAD BASIC	1 DEC. PL. ± 0.4 2 DEC. PL. ± 0.15 ANGULAR ± 0.5 DEG.			1	10.01.08	DOI 7811						
FINISH.	REMOVE ALL BURRS.				2	17.03.08	DOM22706						
CLEAN		SURFACE TEXTURE	ThermoFisher Scientific Bath Road, Beenham, Reading, Berkshire, RG7 5PR, ENGLAND.										
		UNLESS STATED											
MANUFACTURE TO DIMENSIONS SHOWN. FINISHING ALLOWANCE ALREADY DEDUCTED		DIMENSIONS IN MILLIMETRES	SCALE	N/A	TITLE				DRG.No.				
			PM12 LEAD BASIC 0.5" LEAD KIT				11705078						

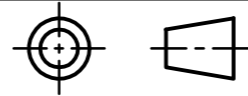
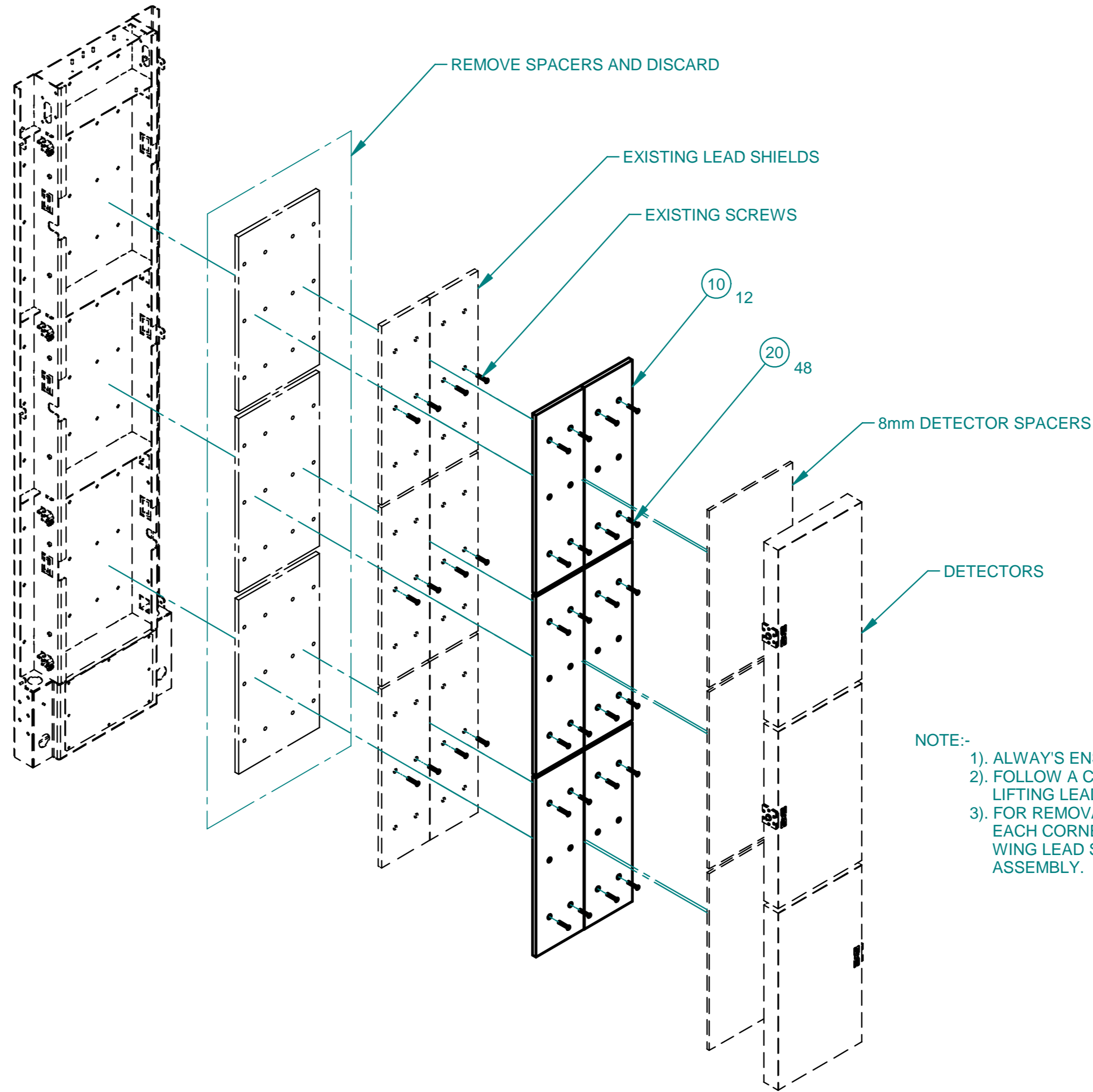

ILLUSTRATION SHOWING ONLY ONE SIDEFRAE.
LEAD QUANTITIES ON BALLONS ARE CORRECT
FOR COMPLETE ASSEMBLY.



NOTE:-

- 1). ALWAYS ENSURE THE USE OF GLOVES WHEN HANDLING LEAD.
- 2). FOLLOW A CORRECT AND SAFE LIFTING PROCEEDURE WHEN LIFTING LEAD SHIELDS INTO POSITION.
- 3). FOR REMOVAL OF THE TWO INNER COVERS AND 4 SCREW'S ON EACH CORNER SECTION TO ALLOW ACCESS FOR FITTING THE WING LEAD SHIELDS. REFER TO DRG. 11705121 FOR MAINFRAME ASSEMBLY.

CONFIDENTIALITY NOTICE: THIS DOCUMENT (INCLUDING ALL INFORMATION CONTAINED THEREIN) IS OWNED BY ThermoFisher SCIENTIFIC AND MUST BE KEPT IN CONFIDENCE AND USED SOLELY FOR THE OWNER'S SPECIFIED PURPOSES. THIS DOCUMENT MUST NOT BE COPIED OR REPRODUCED, NOR DIVULGED, IN WHOLE OR PART, WITHOUT THE OWNER'S PRIOR WRITTEN CONSENT.

ISO THREADS CLASS 6g/6H

MATL. SEE BOM PM12 LEAD ADDIT		TOLERANCES UNLESS STATED 1 DEC. PL. ± 0.4 2 DEC. PL. ± 0.15 ANGULAR ± 0.5 DEG.		DRAWN	GEL	ISS.	DATE	DOI/MOD.						
SPEC. SEE BOM PM12 LEAD ADDIT						1	10/01/08	DOI 7811						
FINISH. REMOVE ALL BURRS. CLEAN	SURFACE TEXTURE UNLESS STATED	DIMENSIONS IN MILLIMETRES SCALE 1:10		ThermoFisher SCIENTIFIC Bath Road, Beenham, Reading, Berkshire, RG7 5PR, ENGLAND.					TITLE PM12 LEAD ADDITIONAL (1" LEAD KIT)		DRG.No. 11705079			
MANUFACTURE TO DIMENSIONS SHOWN. FINISHING ALLOWANCE ALREADY DEDUCTED														



ILLUSTRATION SHOWING ONLY ONE SIDEFRAE.
LEAD QUANTITIES ON BALLONS ARE CORRECT
FOR COMPLETE ASSEMBLY.

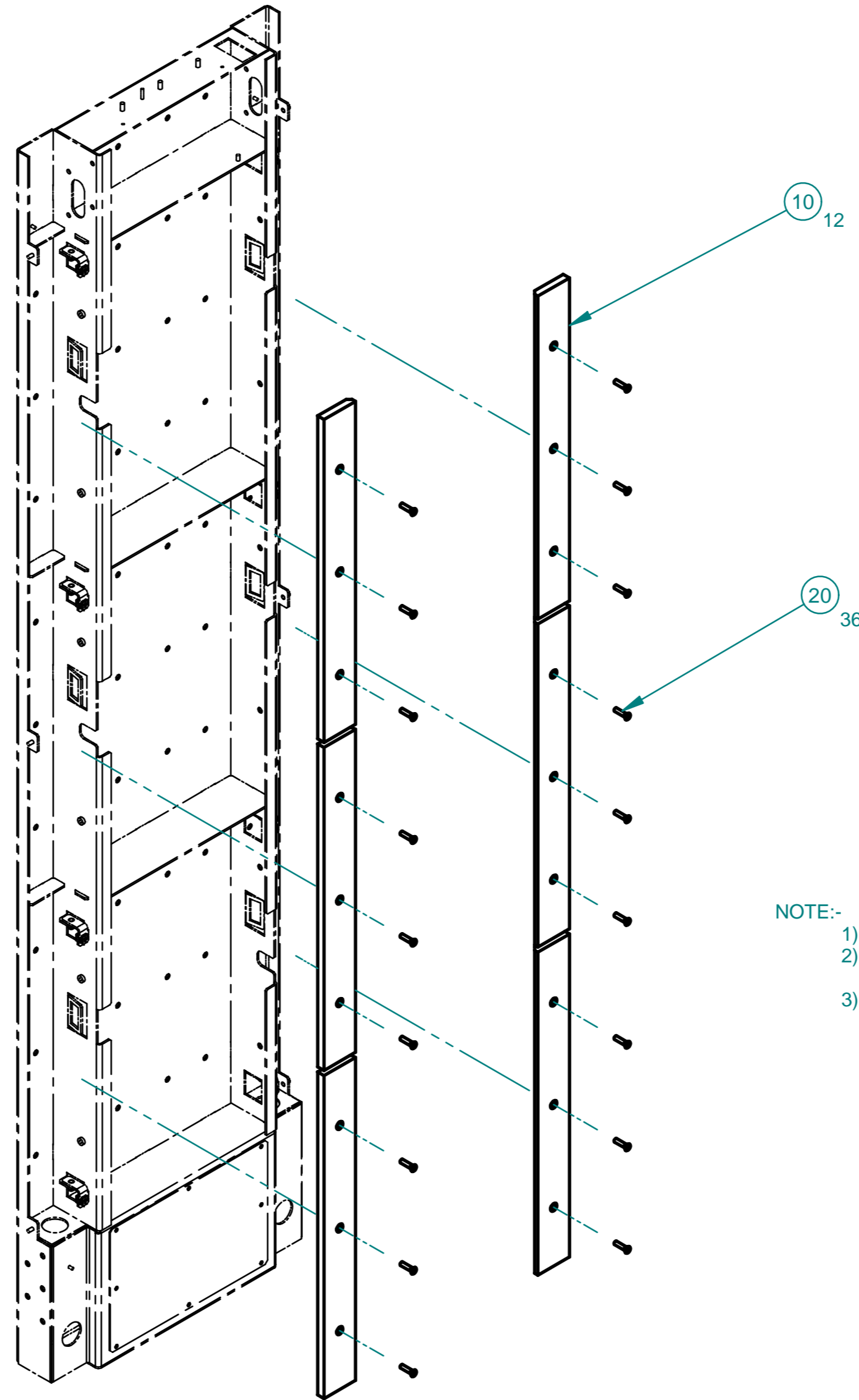

NOTE:-

- 1). ALWAYS ENSURE THE USE OF GLOVES WHEN HANDLING LEAD.
- 2). FOLLOW A CORRECT AND SAFE LIFTING PROCEEDURE WHEN LIFTING LEAD SHIELDS INTO POSITION.
- 3). FOR REMOVAL OF THE TWO INNER COVERS AND 4 SCREW'S ON EACH CORNER SECTION TO ALLOW ACCESS FOR FITTING THE WING LEAD SHIELDS. REFER TO DRG. 11705121 MAINFRAME ASSEMBLY.

CONFIDENTIALITY NOTICE: THIS DOCUMENT (INCLUDING ALL INFORMATION CONTAINED THEREIN) IS OWNED BY ThermoFisher SCIENTIFIC AND MUST BE KEPT IN CONFIDENCE AND USED SOLELY FOR THE OWNER'S SPECIFIED PURPOSES. THIS DOCUMENT MUST NOT BE COPIED OR REPRODUCED, NOR DIVULGED, IN WHOLE OR PART, WITHOUT THE OWNER'S PRIOR WRITTEN CONSENT.

ISO THREADS CLASS 6g/6H

MATL. SEE BOM PM12 LEAD WINGS		TOLERANCES UNLESS STATED 1 DEC. PL. ± 0.4 2 DEC. PL. ± 0.15 ANGULAR ± 0.5 DEG.	DRAWN	GEL	ISS.	DATE	DOI/MOD.							
SPEC. SEE BOM PM12 LEAD WINGS					1	10/01/08	DOI 7811							
FINISH. REMOVE ALL BURRS. CLEAN	SURFACE TEXTURE ✓ UNLESS STATED	DIMENSIONS IN MILLIMETRES	ThermoFisher SCIENTIFIC Bath Road, Beenham, Reading, Berkshire, RG7 5PR, ENGLAND.											
MANUFACTURE TO DIMENSIONS SHOWN. FINISHING ALLOWANCE ALREADY DEDUCTED		SCALE N/A												TITLE PM12 LEAD WINGS KIT

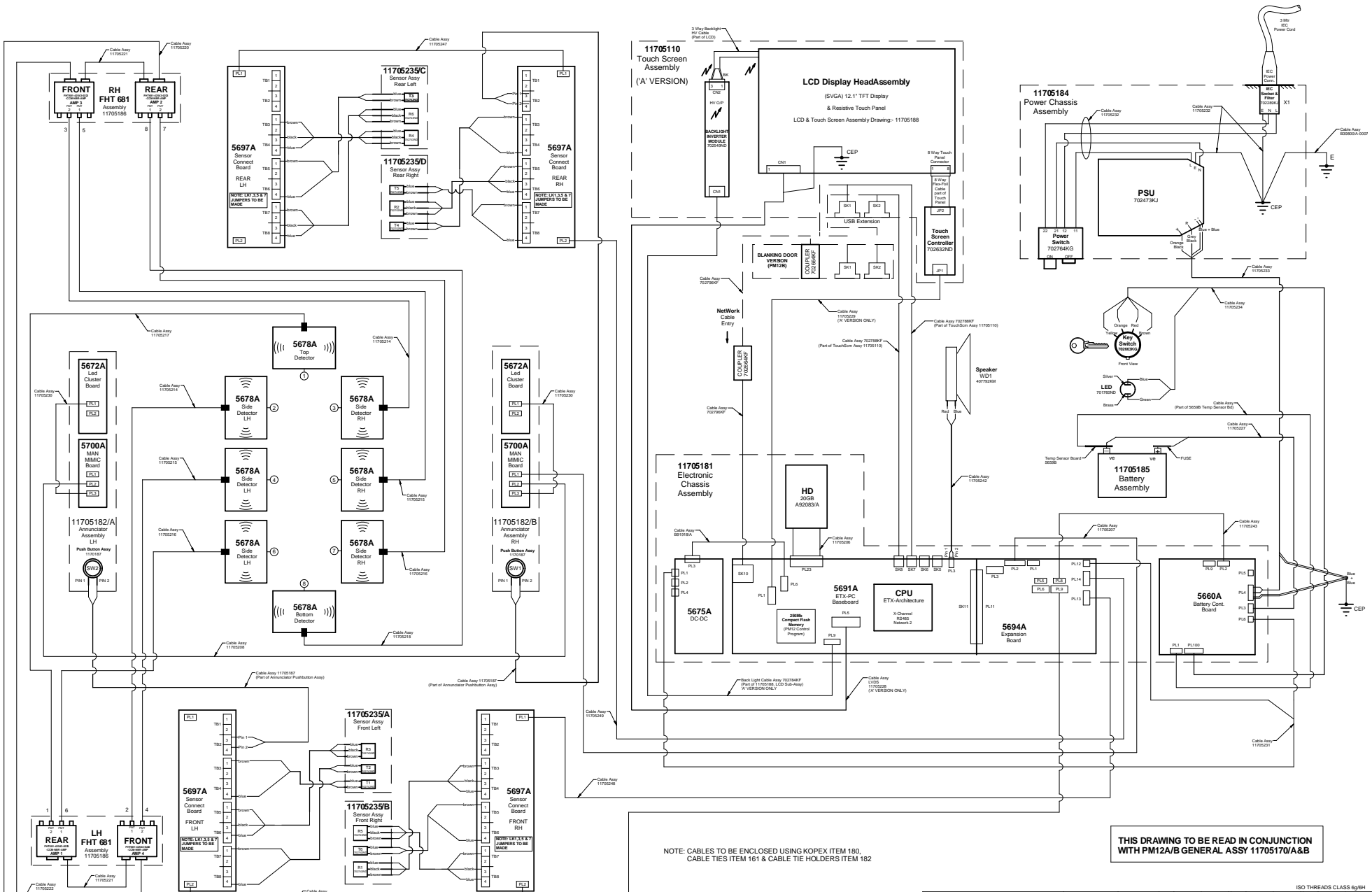

NOTE: CABLES TO BE ENCLOSED USING KOEXIP ITEM 180.
 CABLE TIES ITEM 161 & CABLE TIE HOLDERS ITEM 162

THIS DRAWING TO BE READ IN CONJUNCTION
 WITH PM12A/B GENERAL ASSY 11705170/A&B

CONFORMANCE: THIS DRAWING SHALL BE MADE IN CONFORMANCE WITH THE REQUIREMENTS OF THE EUROPEAN DIRECTIVE ON THE REDUCTION OF THE HAZARDOUS SUBSTANCE IN THE MANUFACTURE OF ELECTRICAL AND ELECTRONIC EQUIPMENT (ROHS) AND THE REUSE OF ELECTRICAL AND ELECTRONIC EQUIPMENT (WEEE).

MATERIALS		TOLERANCES UNLESS SPECIFIED		DRAWN		GEL		ISS.		DATE		DIMENSIONS		ISO THREADS CLASS G/6H	
MATL:	N/A	1 DEC.	PL ± 0.4	1	25.11.07	1	25.11.07	1	25.11.07	1	25.11.07	1	25.11.07	1	25.11.07
SPEC:	N/A	2 SURFACE	ANGULAR ± 0.5 DEG.	2	17.04.08	2	06.02.24	2	06.02.24	2	06.02.24	2	06.02.24	2	06.02.24
FINISH:	REMOVE ALL BURRS.	SURFACE TEXTURE	UNLESS STATED	SCALE: N/A		TITLE: PM12 INTERCONNECTION DIAGRAM		QUAD SENSOR BOARD		ORIG. NO. 11705190					

ThermoFisher SCIENTIFIC Bath Road, Beaumont, Reading, Berkshire, RG7 5PR, ENGLAND.

11705191

DO NOT SCALE

THIRD ANGLE PROJECTION

IF IN DOUBT ASK!

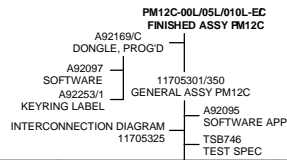

11705302
PM12C FRAME ASSEMBLY

- 11705073 SIDE FRAME FAB STAGE 2
 - 11705070 SIDE FRAME FAB STAGE 1
 - 11705016 SIDE FRAME BACKPLATE
 - 11705219 SIDE FRAME LOWER PLATE
 - 11705020 BOTTOM LEAD SUPPORT
 - 11705021 SIDE FRAME INSERT
 - 11705060 TOP DETECTOR SHELF
 - 11705061 DETECTOR SHELF
 - 11705061 DETECTOR SHELF
 - 11705080 SIDE FRAME ANGLE LH
 - 11705081 SIDE FRAME ANGLE RH
 - 11705100 BRACKET
- 117050303 LOWER PLINTH FAB-PM12C
 - 11705304 LOWER PLINTH SHELL-PM12C
 - 11705025 LOWER PLINTH BRACKET
 - 11705084 LOWER PLINTH SUPPORT ANGLE
 - 11705085 LOWER PLINTH FORK ENTRY
 - 11705086 LOWER PLINTH SPACER
- 11705305 TOP PLINTH FAB-PM12C
 - 11705306 TOP PLINTH SHELL-PM12C
 - 11705026 UPPER PLINTH BRACKET
- 11705076 COVER INNER ASSEMBLY
 - 11705031 INNER SIDE COVER
- 11705090 COVER OUTER ASSEMBLY
 - 11705030 OUTER COVER
 - 11705091 OUTER COVER BRACKET
- 11705099 TREAD PLATE OUTER BRACKET ASSY
 - 11705094 TIE BAR
 - 11705095/1 END BRACKET LH
 - 11705095/2 END BRACKET RH
 - 11705097/2 BRACKET RH
 - 11705097/1 BRACKET LH

- 11705027 CORNER SECTION
- 11705029 CORNER SECTION ANNUNCIATOR
- 11705308 CORNER SECTION ANNUN LH-PM12C
- 11705266 CORNER SECTION LCD/BLANKING FAB
- 11705062 CORNER SECTION LCD
- 11705265 TOUCH SCRNN PIVOT BKT
- 11705083 COVER PLATE
- 11705088 FLOOR SUPPORT OUTER
- 11705150 BATTERY BOX
- 11705196 SENSOR BOARD CHASSIS
- 11705033 TOP LEAD HOLDING BRACKET
- 11705323 TOP LID - PM12C
- 11705048 FOOT TREAD PLATE
- 11705310 SENSOR BD & DOOR CONT CHASSIS-PM12C

- 11705315 DOOR FRAME TOP SECT FAB-PM12C
 - 11705316 DOOR FRAME TOP SECT-PM12C
 - 11705317 DOOR FRAME TOP SECT WEB-PM12C
- 11705318 DOOR FRAME SIDE PLATE RH
- 11705319 DOOR FRAME SIDE PLATE LH
- 11705320 DOOR FRAME BOTTOM BRACKET
- 11705321 BARRIER ARM-PM12C
- 11705309 BARRIER MOTOR MOUNTING BRACKET-PM12C
- 11705324 BARRIER ARM SCREW COVER-PM12C
- 11705326 POWERED DOORS MODIFIED-PM12C

- 11705339 PM12C-PSU ASSEMBLY
 - 11705333 CABLE ASSY-MAINS-PM12C
 - 11705349/A LABEL KIT - PM12C (CH)
 - 11705340 LABEL MAINS (CHINESE)
 - 11705341 LABEL KEYSWTH (CHINESE)
 - 11705192 LABEL CORNER COVER
 - 11705197 LABEL SIDE PANEL

- 11705312 GPIO POWER CHASSIS ASSY-PM12C
 - 11705313 GPIO POWER CHASSIS BASE-PM12C
 - 11705314 GPIO POWER CHASSIS COVER-PM12C
 - 5707A GPIO BOARD
 - E92343/A G.A
 - E92342/1 P.C BOARD MACHINING
 - E92341 CIRCUIT DIAGRAM
- 11705330 CABLE ASSY-MOTOR INT-PM12C
- 11705331 CABLE ASSY-COMMS & POWER-PM12C
- 11705332 CABLE ASSY-DOOR MAINS-PM12C
- 11705334 CABLE ASSY-POWER STATUS-PM12C
- 11705335 CABLE ASSY-FRAME EARTH 100mm -PM12C
- 11705336 CABLE ASSY-FRAME EARTH 250mm -PM12C
- 11705337 CABLE ASSY-FRAME EARTH 550mm -PM12C

- 11705110 TOUCH SCREEN ASSEMBLY (AS PM12A)
- 11705181 ELECTRONIC CHASSIS ASSEMBLY (AS PM12A/B)
 - 5697A SENSOR CONNECT BOARD (AS PM12A/B)
 - 11705348/A (CHINESE) ANNUNCIATOR LH ASSEMBLY
 - 11705042 ANNUNCIATOR COVER
 - 11705187 PM12 ANNUN PSHBTN ASSY
 - 11705343 LHS GRAPHIC OVERLAY
 - 11705230 CABLE ASSY 5672A-5700A
 - 5672A 5 WAY LED CLUSTER BOARD
 - 5700A 7 SEGMENT & MIMIC BOARD
- 11705348/B (CHINESE) ANNUNCIATOR RH ASSEMBLY
 - 11705042 ANNUNCIATOR COVER
 - 11705187 PM12 ANNUN PSHBTN ASSY
 - 11705342 LHS GRAPHIC OVERLAY
 - 11705230 CABLE ASSY 5672A-5700A
 - 5672A 5 WAY LED CLUSTER BOARD
 - 5700A 7 SEGMENT & MIMIC BOARD
- 11705182/A (ENG) ANNUNCIATOR LH ASSEMBLY (AS PM12A/B)
- 11705182/B (ENG) ANNUNCIATOR RH ASSEMBLY (AS PM12A/B)

- 11705185 PM12-BATTERY ASSEMBLY (AS PM12A/B)
 - 11705186 PM12-FHT681 ASSEMBLY (AS PM12A/B)
 - 11705235/A SENSOR ASSY FRONT LEFT (AS PM12A/B)
 - 11705235/B SENSOR ASSY FRONT RIGHT (AS PM12A/B)
 - 11705235/C SENSOR ASSY REAR LEFT (AS PM12A/B)
 - 11705235/D SENSOR ASSY REAR RIGHT (AS PM12A/B)

- 11705012 TOP/BOTTOM LEAD SHIELD
- 11705108 (A VERSIONS ONLY) PIVOT BUSH
- 11705192 LOGO LABEL PM12 CORNER COVER
- 11705194(ENG) LABEL MAINS PM12
- 11705195(ENG) LABEL KEYSWITCH PM12
- 11705197 LOGO LABEL PM12 SIDE PANEL
- 11705207 CABLE ASSY-PM12 12C CABLE 1
- 11705208 CABLE ASSY-ANNUNCIATOR INTERCONNECT
- 11705214 CABLE COAX MHV-PET 650mm
- 11705215 CABLE COAX MHV-PET 1230mm
- 11705216 CABLE COAX MHV-PET 1810mm
- 11705217 CABLE COAX MHV-PET 800mm
- 11705218 CABLE COAX MHV-PET 2810mm
- 11705220 CABLE ASSY 5694A-AMP X COMMS
- 11705221 CABLE ASSY INTER-AMP X COMMS
- 11705222 CABLE ASSY PAIRED-AMP X COMMS
- 11705234 CABLE ASSY KEYSWITCH
- 11705240/1 (A VERSIONS ONLY) TOUCHSCREEN SPACER BOTTOM
- 11705240/2 (A VERSIONS ONLY) TOUCHSCREEN SPACER TOP
- 11705242 CABLE ASSY SPEAKER
- 11705245 NETWORK BRACKET
- 11705246 DETECTOR STRAP ASSY
- 11705247 CABLE ASSY-SENSOR INTERCONNECT
- 11705248 CABLE ASSY-FRONT SENSOR TO CHASSIS
- 11705249 CABLE ASSY-SENSOR I/O REAR
- 11705257(E)/344(CH) LABEL - DETECTOR REMOVAL
- 11705258(E)/345(CH) LABEL - BATTERY ENCLOSURE
- 11705259(E)/346(CH) LABEL - FHT AMPLIFIER R/H
- 11705260(E)/347(CH) LABEL - FHT AMPLIFIER L/H
- 11705261 LABEL - ON/OFF IDENT
- 11705263 KEYSWITCH EARTHING PLATE
- B92294/A EARTH LEAD ASSY, SIDE PANEL
- B92295/A EARTH LEAD, FRAME-SIDE PANEL
- A90344/1 LABEL

CONFIDENTIALITY NOTICE: THIS DOCUMENT INCLUDING ALL INFORMATION CONTAINED THEREIN IS THE PROPERTY OF THERMO FISHER SCIENTIFIC. IT IS TO BE USED ONLY FOR THE PURPOSES SPECIFIED HEREIN. IT IS NOT TO BE REPRODUCED, COPIED, OR DISCLOSED IN WHOLE OR IN PART, WITHOUT THE OWNERS PRIOR WRITTEN CONSENT.

MATL.	TOLERANCES UNLESS STATED	DRAWN	PRW	ISS.	DATE	DOI/MOD.							
SPEC.	1 DEC. PL ± 0.4 2 DEC. PL ± 0.15 ANGULARS ± 0.5 DEG.			1	24/01/08	DOI7810							
FINISH. REMOVE ALL BURRS.	SURFACE TEXTURE			2	09/04/08	DOI22734							
	DIMENSIONS IN MILLIMETRES			3	23/08/08	DOI7872							
	SCALE	ThermoFisher SCIENTIFIC Bath Road, Beenham, Reading, Berkshire, RG7 5PR, ENGLAND.											
MANUFACTURE TO DIMENSIONS SHOWN. FINISHING ALLOWANCE ALREADY DEDUCTED	UNLESS STATED	TITLE	PM12 SERIES FAMILY TREE									DRG.No.	11705191
												SH2	OF2

11705270

DRG No.

DO NOT SCALE

THIRD ANGLE PROJECTION



IF IN DOUBT ASK!

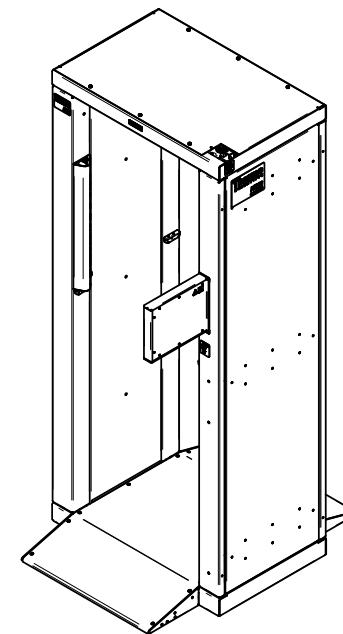
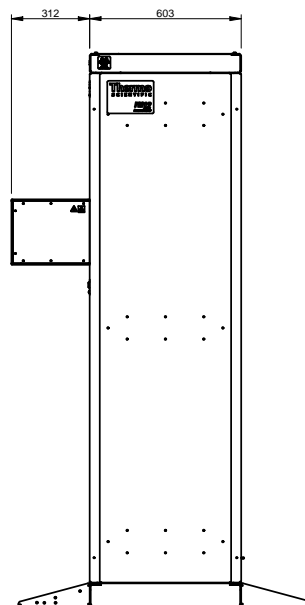
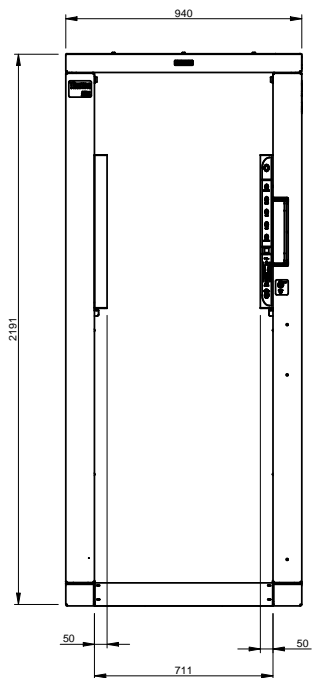
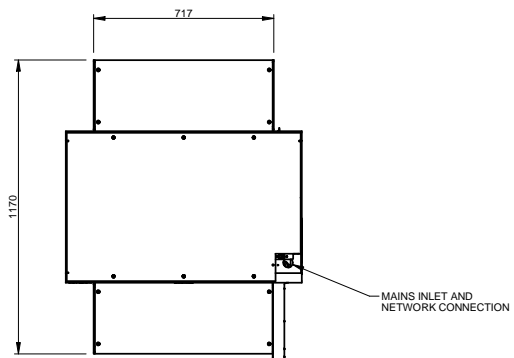

CONFIDENTIALITY NOTICE: THIS DOCUMENT INCLUDING ALL INFORMATION CONTAINED THEREIN IS THE PROPERTY OF THERMO FISHER SCIENTIFIC. IT IS TO BE USED ONLY FOR THE PURPOSES SPECIFIED AND IS NOT TO BE REPRODUCED, COPIED, OR DISCLOSED IN WHOLE OR IN PART, WITHOUT THE WRITTEN CONSENT OF THERMO FISHER SCIENTIFIC.

ISO THREADS CLASS 6g/6h

MATERIAL		TOLERANCES UNLESS STATED		DRAWN		ISS.		DATE		DOI/MOD.									
SPEC.		1 DEC. PL ± 0.4 2 DEC. PL ± 0.15 ANGULARS ± 0.5 DEG.				A		01/02/08											
FINISH: REMOVE ALL BURRS.		SURFACE TEXTURE		DIMENSIONS IN MILLIMETRES				Bath Road, Beenham, Reading, Berkshire, RG7 5PR, ENGLAND.		TITLE		DRG.No.							
		UNLESS STATED		SCALE 1:10															
MANUFACTURE TO DIMENSIONS SHOWN. FINISHING ALLOWANCE ALREADY DEDUCTED																			

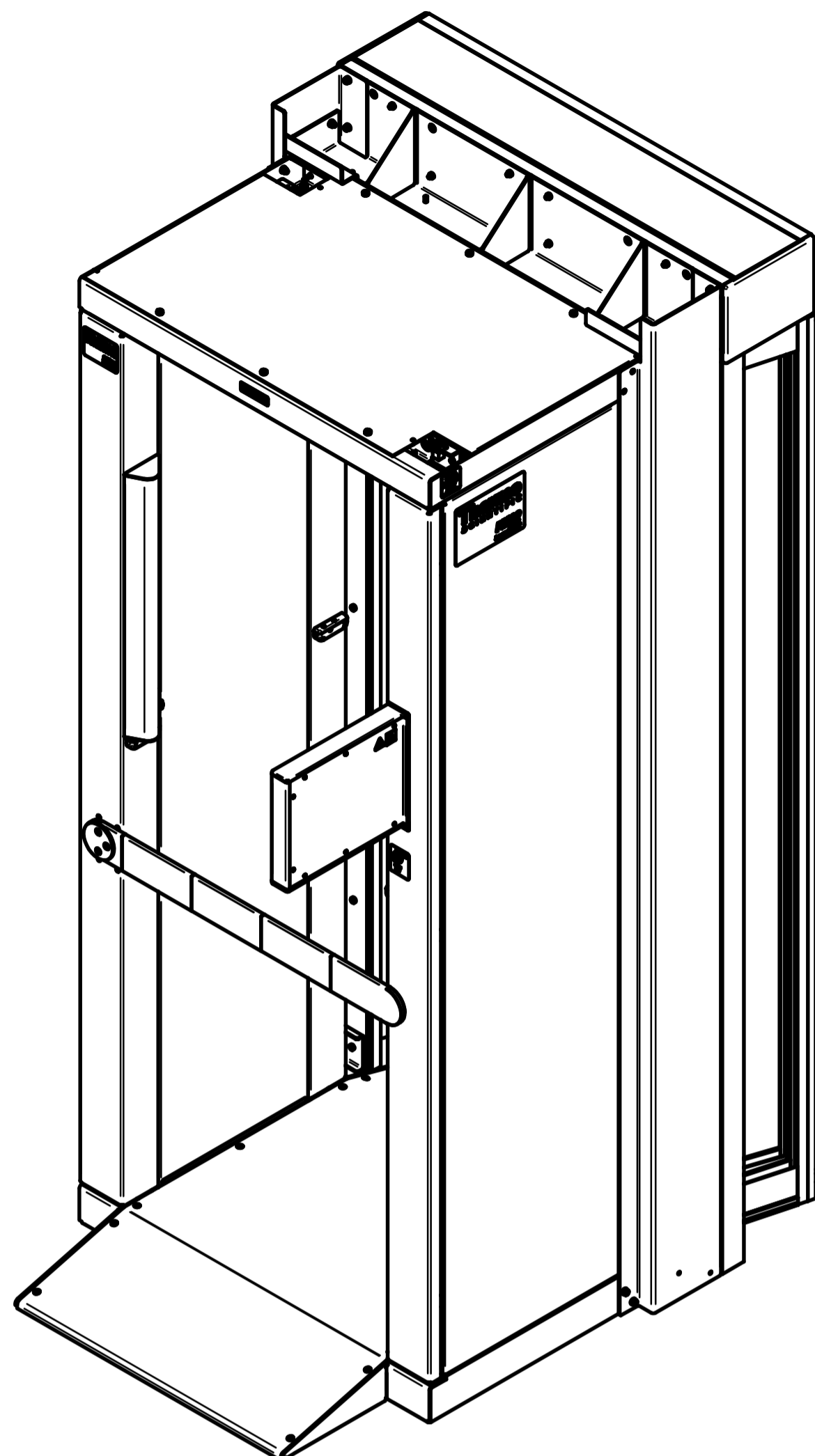

**BARRIER ARM
ENTRANCE VIEW
(DOORS FULLY OPEN)**

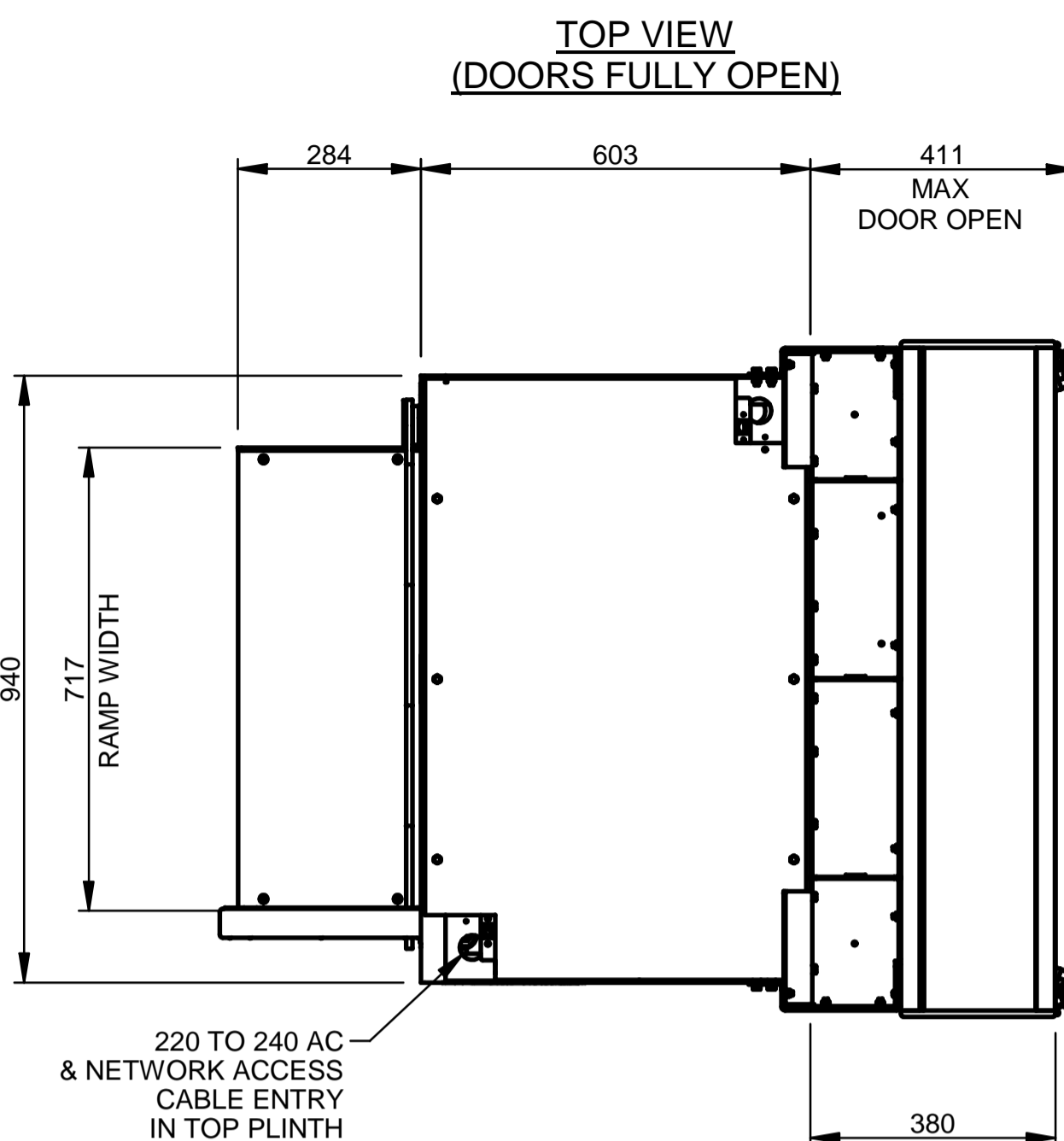

220 TO 240 AC
& NETWORK ACCESS
CABLE ENTRY
IN TOP PLINTH

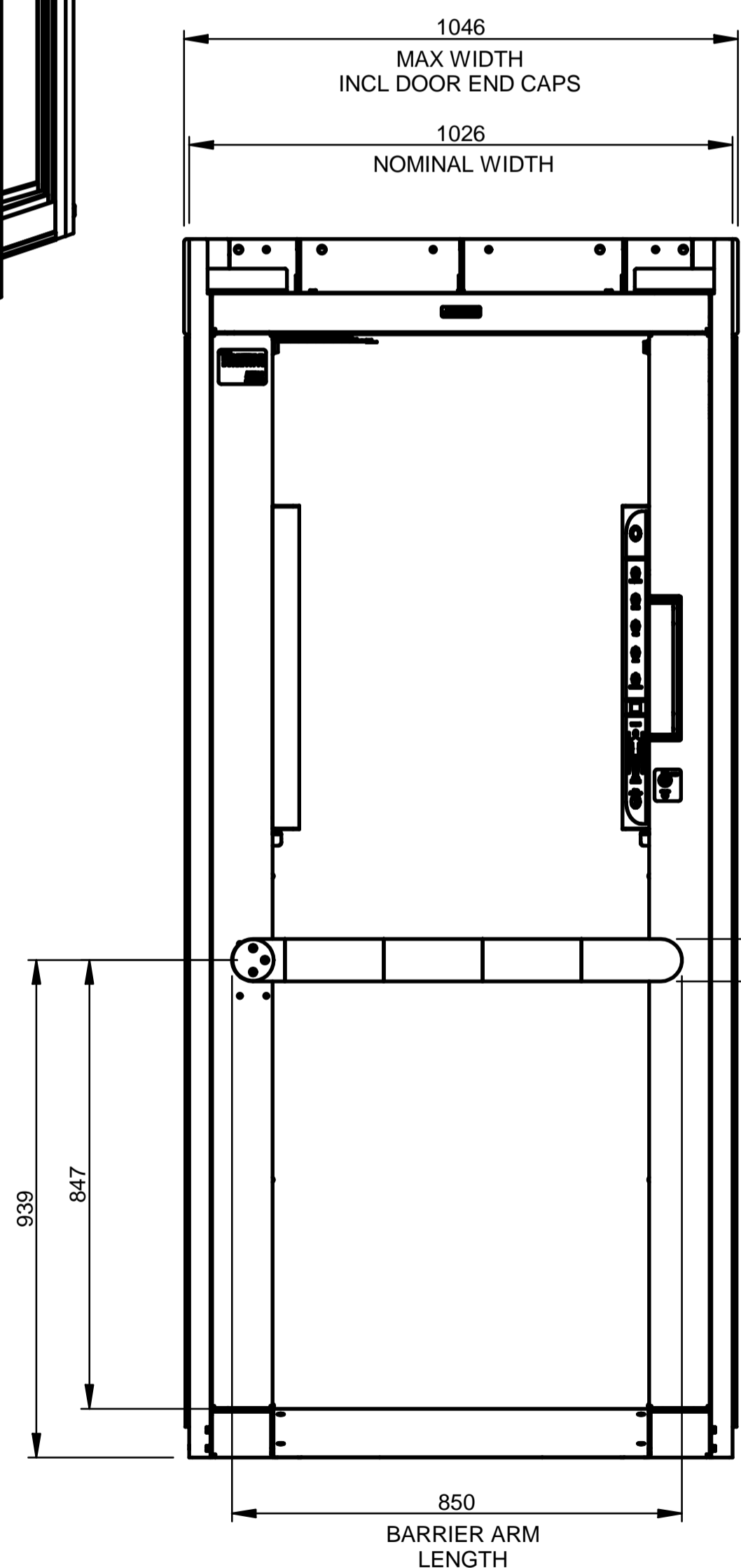

**BARRIER ARM
ENTRANCE VIEW
(DOORS FULLY OPEN)**

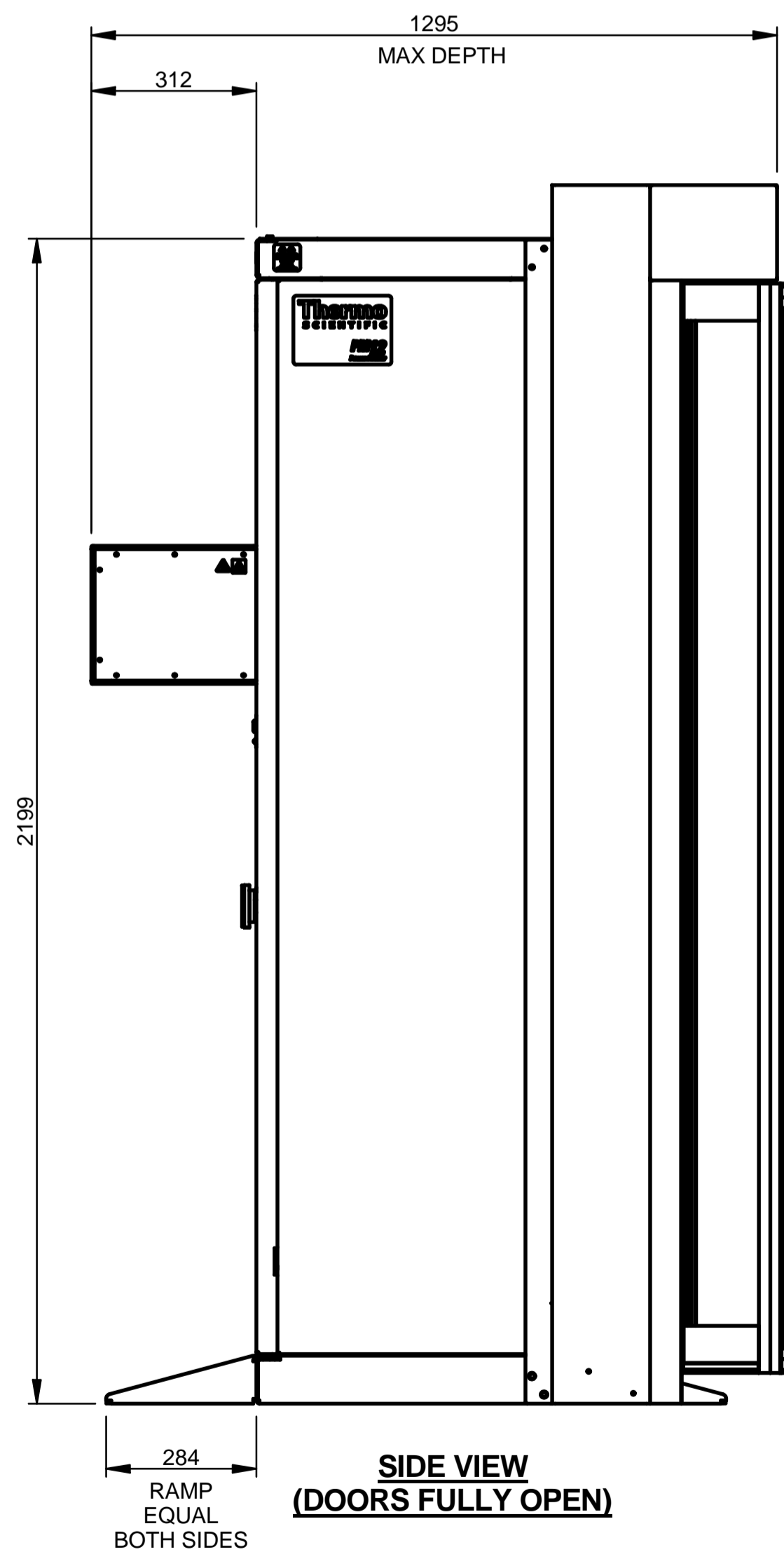

**SIDE VIEW
(DOORS FULLY OPEN)**

220 - 240V AC
& NETWORK ACCESS
CABLE ENTRY
IN TOP PLINTH

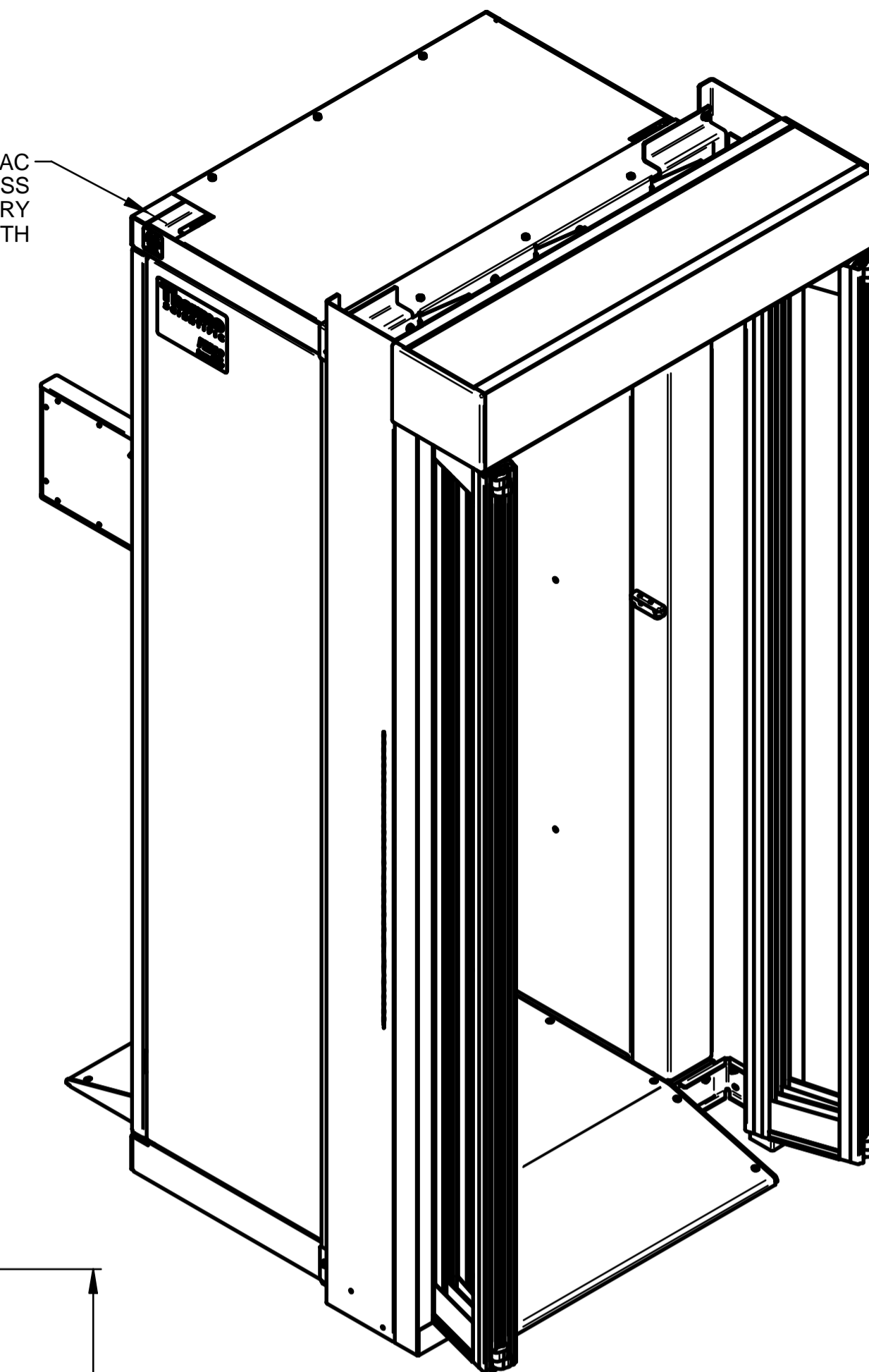

**AUTOMATED DOOR EXIT VIEW
(DOORS PARTIALLY OPEN)**

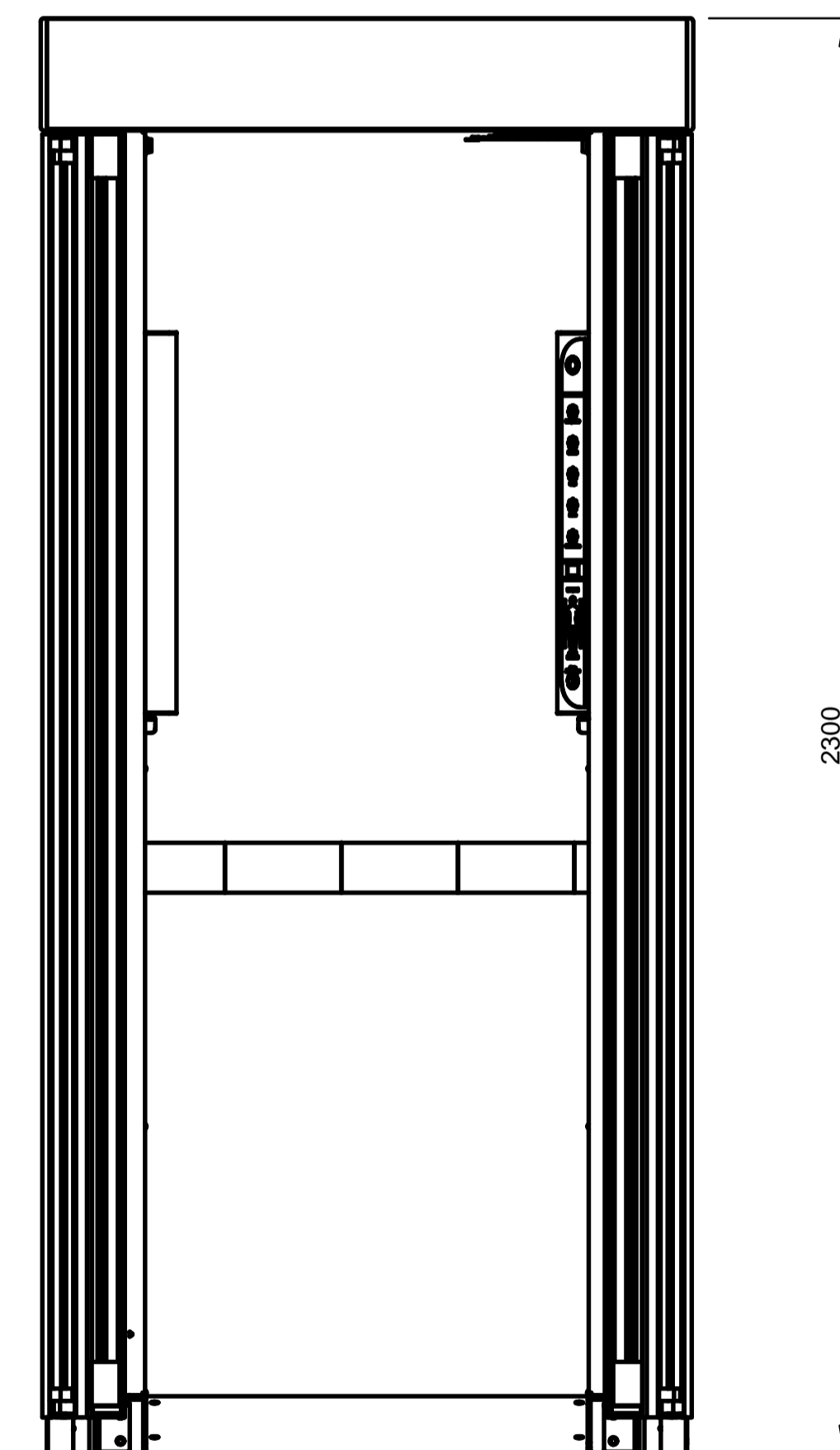

**AUTOMATED DOOR EXIT VIEW
(DOORS OPEN)**

CONFIDENTIALITY NOTICE: THIS DOCUMENT (INCLUDING ALL INFORMATION CONTAINED THEREIN) IS OWNED BY ThermoFisher Scientific and MUST BE KEPT IN CONFIDENCE AND USED SOLELY FOR THE OWNER'S SPECIFIED PURPOSES. THIS DOCUMENT MUST NOT BE COPIED OR REPRODUCED, NOR DIVULGED, IN WHOLE OR PART, WITHOUT THE OWNER'S PRIOR WRITTEN CONSENT.

ISO THREADS CLASS 6g/6H

MATL.	TOLERANCES UNLESS STATED	DRAWN	RES	ISS.	DATE	DOI/MOD.												
SPEC.	1 DEC. PL ± 0.4 2 DEC. PL ± 0.15 ANGULAR ± 0.5 DEG.			1	13/10/08	DOI7872												
FINISH. REMOVE ALL BURRS.	SURFACE TEXTURE	DIMENSIONS IN MILLIMETRES		ThermoFisher Scientific		Bath Road, Beenham, Reading, Berkshire, RG7 5PR, ENGLAND.		TITLE		DRG.No.								
	✓ UNLESS STATED	SCALE 1:10		PM12C OUTLINE DRAWING		11705300												
MANUFACTURE TO DIMENSIONS SHOWN. FINISHING ALLOWANCE ALREADY DEDUCTED																		

11705325

DO NOT SCALE THIRD ANGLE PROJECTION IF IN DOUBT ASK!

- Assembly Notes:
1. Remove all existing connectors from Motor Assy (if fitted).
 2. Add Ferrite 702053KF to Red & Black Wires (1 complete turn).
 3. Trim Switch Wires to same length as Red & Black.
 4. Comp Pin 7011539KF to all 6 wires, assemble to Housing 701113KF as detailed below

Wire Color	To Pin No.	Notes
Black	1	Attach Ferrite 702053KF (with 1 complete turn of wire) before termination
Red	2	Attach Ferrite 702053KF (with 1 complete turn of wire) before termination
Orange	7	From Barrier down Switch
Brown	9	From Barrier up Switch
White	10	From Barrier down Switch
Green	12	From Barrier up Switch

Wire Color	From Cable Assy	To Pin No.	Notes
Red	11705334	1	
Black	11705334	1 & 4	150mm Link Wire 508503BC
Black	11705330	3 & 6	150mm Link Wire 508501BC
Red	11705330	5	
Black	11705330	2	

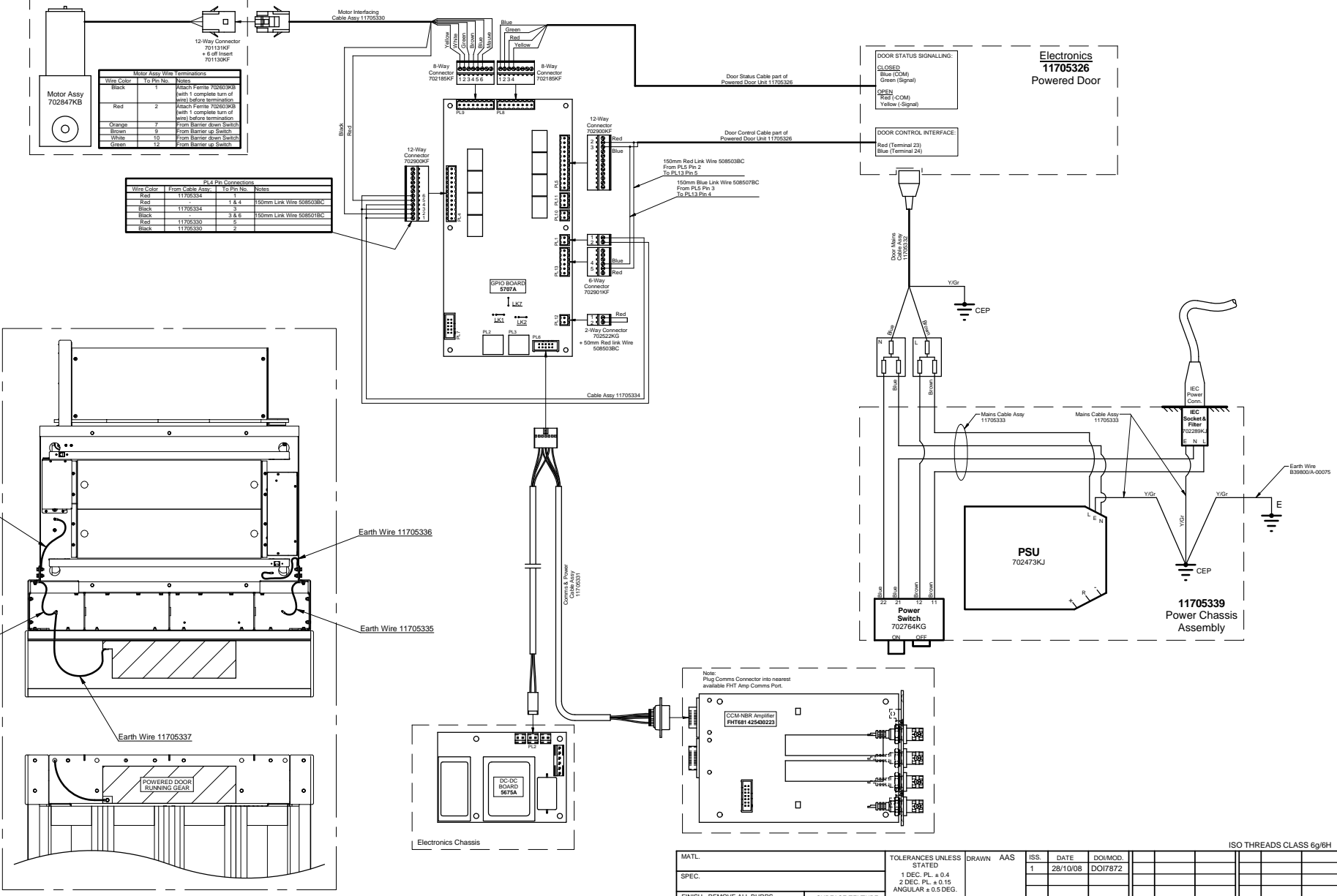

CONFIDENTIALITY NOTICE: THIS DOCUMENT INCLUDING ALL INFORMATION CONTAINED THEREIN IS THE PROPERTY OF THERMO FISHER SCIENTIFIC. IT IS TO BE USED FOR THE SPECIFIC PURPOSES SPECIFIED HEREIN. IT IS NOT TO BE REPRODUCED, COPIED, OR DISCLOSED IN WHOLE OR IN PART, WITHOUT THE OWNERS PRIOR WRITTEN CONSENT.

Additional Frame Earth Cabling

MATL.	TOLERANCES UNLESS STATED	DRAWN	AAS	ISS.	DATE	DOI/MOD.	ISO THREADS CLASS 6g/6H		
SPEC.	1 DEC. PL ± 0.4 2 DEC. PL ± 0.15 ANGULAR ± 0.5 DEG.	1		1	28/10/08	DOI7872			
FINISH. REMOVE ALL BURRS.	SURFACE TEXTURE	DIMENSIONS IN MILLIMETRES		ThermoFisher SCIENTIFIC Bath Road, Beenham, Reading, Berkshire, RG7 5PR, ENGLAND.			TITLE		
UNLESS STATED	SCALE	N.T.S.		MANUFACTURE TO DIMENSIONS SHOWN. FINISHING ALLOWANCE ALREADY DEDUCTED			DRG.No. 11705325		